



# A Complete Range of Solenoid Valves for Fluid Control

General Catalogue

aerospace  
climate control  
electromechanical  
filtration  
fluid & gas handling  
hydraulics  
pneumatics  
process control  
sealing & shielding



ENGINEERING YOUR SUCCESS.



> 5,000

Product references

**This catalogue is a comprehensive list of Parker FCDE products. It will help to identify appropriate valves and coils and enable the user to generate ordering numbers.**

**The catalogue is intended for use by Parker Sales personnel with the aim to select the most suitable solenoid valves for customers.**



**WARNING - USER RESPONSIBILITY**

**FAILURE OR IMPROPER SELECTION OR IMPROPER USE OF THE PRODUCTS DESCRIBED HEREIN OR RELATED ITEMS CAN CAUSE DEATH, PERSONAL INJURY AND PROPERTY DAMAGE.**

- This document and other information from Parker-Hannifin Corporation, its subsidiaries and authorized distributors provide product or system options for further investigation by users having technical expertise.
- The user, through its own analysis and testing, is solely responsible for making the final selection of the system and components and assuring that all performance, endurance, maintenance, safety and warning requirements of the application are met. The user must analyze all aspects of the application, follow applicable industry standards, and follow the information concerning the product in the current product catalog and in any other materials provided from Parker or its subsidiaries or authorized distributors.
- To the extent that Parker or its subsidiaries or authorized distributors provide component or system options based upon data or specifications provided by the user, the user is responsible for determining that such data and specifications are suitable and sufficient for all applications and reasonably foreseeable uses of the components or systems.



# PARKER FCDE

## Who we are?

*The Fluid Control Division in Europe (FCDE) is a division of Parker Hannifin, the global leader in motion and control technologies.*

*FCDE core competences are the development and manufacturing of an extremely diverse range of fluid control products, including solenoid valves and pressure regulators.*

## Where we are?

*Our European headquarters are located in Geneva, this is also where our R&D, Marketing, Application Support and Product Management functions are located.*

*FCDE Products are mainly manufactured at locations in Carouge (Geneva - Switzerland) and Gessate (Milan - Italy).*

*The Parker Sales Companies and comprehensive distribution network support you, wherever you are.*

## History

Parker FCDE has been a leading player in the manufacturing and development of solenoid valve technologies for over 60 years, with continuous research and development bringing innovative solutions to the marketplace, for example leading the way in the utilisation of synthetic ruby for critical water applications or the unsurpassed reliability and precision of our pressure regulators. The expertise accumulated and developed through the years is evident in the superior quality of FCDE solutions.

## Markets

Our products and solutions are typically designed for markets including Industrial Equipment, Industrial Automation, Mobile, Transportation, Life Sciences, Beverage dispensing and for Fluid and Process Control.

## Benefits

The modular concept of our products, having separate solenoid valves and electrical parts, provides the customer with increased flexibility by allowing numerous combinations. This additional flexibility can enable distributors to greater reduce valve inventory levels, whilst retaining the same number of capabilities. Parker also has unrivalled experience in developing customised product solutions complying with the highest technical, environmental, energy and service life requirements.



PARKER FCDE - GENEVA - SWITZERLAND



PARKER FCDE - MILAN - ITALY



# GENERAL CATALOGUE FCDE

## TABLE OF CONTENT

### INTRODUCTION

Markets and applications.....	06
A complete range of solenoid valves.....	08
A modular concept.....	10
ATEX Certification.....	12
World class standards.....	13
How to use this catalogue.....	14
How to select a valve.....	16
How to order.....	18
How to use coil groups.....	24

### 2 WAY VALVES

Valves for dry or lubricated air, neutral gases and liquids.....	27
Valves for water and neutral liquids.....	79
Anti water hammer valves.....	113
Hot water and steam valves.....	125
Valves for hydraulic oil and neutral liquids (up to 100 bar).....	141
High corrosion resistant valves (303 Stainless Steel).....	157
High corrosion resistant valves (316L Stainless Steel).....	165
Oil burner valves.....	177
Fast switching valves.....	197
Valves for beverage dispensing - Liquepure®.....	201

### 3 WAY VALVES

Valves for dry or lubricated air, neutral gases and liquids.....	207
Valves for hydraulic oil and neutral liquids (up to 75 bar).....	247
High corrosion resistant valves (303 Stainless Steel).....	251
Valves for beverage dispensing - Liquepure®.....	257

### 2 & 3 WAY VALVES FOR TRANSPORTATION

2 way.....	265
3 way.....	271



## 5 WAY DISTRIBUTORS FOR PNEUMATIC APPLICATIONS

5 way pneumatic distributors (Pipe mounting/Sub-base mounting).....	275
---	-----

## 3 & 5 WAY PNEUMATIC DISTRIBUTORS FOR ACTUATION CONTROL

3 & 5 way pneumatic valves for actuator control (Pipe mounting).....	301
3 & 5 way pneumatic valves for actuator control (NAMUR).....	333
316L Stainless Steel 3 & 5 way valves for actuator control (Pipe mounting and NAMUR).....	375

## ELECTROPNEUMATIC PRESSURE REGULATORS

EPP4 Series - Basic, Comfort , Comfort ATEX Ranges.....	407
---	-----

## COILS, HOUSINGS & ELECTRICAL PARTS

Introduction.....	439
Coils.....	441
Explosion Proof Electrical Parts.....	483
Housings.....	518
Coil Accessories.....	522
Explosive Environments.....	524
Guidance Chart for IS-Barriers.....	534

## TECHNICAL INFORMATION ABOUT SOLENOID VALVES

Technical information about solenoid valves.....	537
--	-----

## APPENDIX

Table of sub-bases for valves.....	558
Table of voltage codes for coils and electrical parts.....	564
Index by Coil Reference.....	568
Index by Coil Group.....	570
Index by Order Number.....	572
Index for Valves.....	574



# MARKETS AND APPLICATIONS

In order to bring customers the best solution, Parker offers a wide range of products that can be divided into specific markets:

## INDUSTRIAL & AUTOMATION

- Compressors
- Blowing
- Textile
- Pressure Regulation



## PROCESS CONTROL

- Valve Actuation
- Oil & Gas
- On & Off-Shore
- Petro-Chemical
- Pharmaceutical



## FOOD & BEVERAGE

- Professional Coffee Machines
- Sparkling Water
- Soft Drinks
- Water Dispensing



## COOLING & CLIMATE CONTROL

- Water dispensing
- Cooling systems



## TRANSPORTATION

- Trucks
- Trains
- Bus and Coach
- Marine
- Military
- Agriculture



## LIFE SCIENCE

- Sterilizers / Autoclaves
- Breathing
- Water purification
- Table-top equipment



## HEATING SYSTEMS

- Industrial Oil Burners
- Fuel Transfer
- Gas Transfer



# A COMPLETE RANGE OF SOLENOID VALVES FOR FLUID CONTROL

## 2 WAY VALVES

- For dry or lubricated air, neutral gases and liquids
- For water and neutral liquids
- Anti water hammer
- Hot water and steam
- For hydraulic oil and neutral liquids (Max. 100 bar)
- High corrosion resistant (303 Stainless Steel) (316L Stainless Steel)
- Oil burner
- Fast switching
- Liquipure® for beverage dispensing



## 3 WAY VALVES

- For dry or lubricated air
- For hydraulic oil and neutral liquids (Max. 75 bar)
- High corrosion resistant (303 Stainless Steel)
- Liquipure® for beverage dispensing



## 2 & 3 WAY VALVES FOR TRANSPORTATION

- 2 way- direct and piloted
- 3 way- direct operated



## 5 WAY DISTRIBUTORS FOR PNEUMATIC APPLICATIONS

- Pipe mounted/ Sub-base mounting



### 3 & 5 WAY PNEUMATIC DISTRIBUTORS FOR ACTUATION CONTROL

- Pipe mounted
- NAMUR interface
- 316L Stainless Steel (Pipe mounted and with NAMUR interface)



### COILS & ELECTRICAL PARTS

- Coils
- Housings
- Explosion-Proof Electrical Parts



### EPP4 SERIES ELECTROPNEUMATIC PRESSURE REGULATORS

- Basic
- Comfort
- Comfort ATEX



## A MODULAR CONCEPT FOR EVERY APPLICATION

CHOOSE BETWEEN:

### Actuation Modes

- Direct Operated
- Magnalift
- Pilot Operated
- Manual Reset
- Externally Operated

### Material Types

- Brass
- 303 Stainless St.
- 316L Stainless St.
- Anodized Aluminium
- Zinc Alloy
- POM

### Mounting Solutions

- Pipe
- Sub-base
- NAMUR
- Banjo
- CETOP
- ISO

### Control Functions

- Normally Closed
- Normally Open
- Universal
- Control by Electric Impulse
- Dual Solenoids
- PWM

### Internal Design

- Piston
- Poppet
- Diaphragm
- Spool

### Seals

- FKM
- NBR
- EPDM
- Ruby
- PUR
- PCTFE...

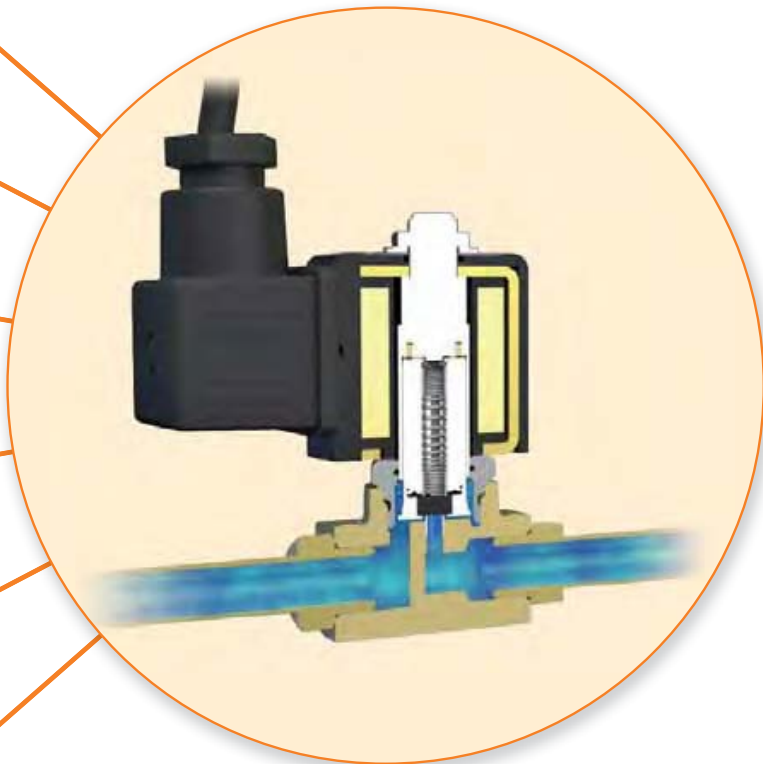

## ATEX CERTIFICATION



### ELECTRICAL PART ATEX CERTIFICATION

A selection of FCDE electrical parts conform to the terms of the 94/9/EC directive and are made for potentially explosive environments - zone 0/20, 1/21 and 2/22.

Within the coil section, the presence of the ATEX logo  shows that the coil is ATEX approved.



### MECHANICAL PART ATEX CERTIFICATION

A selection of FCDE mechanical parts conform to the terms of the 94/9/CE directive specific to non electrical equipment for use within potentially explosive environments - zones 0/20, 1/21 and 2/22.

NAMUR & piped valve ranges now include a marking which indicates mechanical ATEX approval.

Within the valve section, the presence of the ATEX logo  shows that the valve is ATEX approved.



### SOLENOID VALVE CERTIFICATION

When both the electrical and mechanical part are ATEX approved, the solenoid valve can be used in explosive atmospheres.

The solenoid valve will be delivered assembled and tested.



# PARKER FCDE IS MEETING WORLD CLASS STANDARDS

## QUALITY STANDARDS:

- ISO 9001
- ISO 14001
- ISO TS 16949



## CERTIFICATIONS AND APPROVALS:

Our products have been approved and are compliant with the relevant market requirements including:

- CE
- ATEX
- RoHS
- UL
- Reach
- IECEx
- CSA
- Gost
- SVGW
- DIN
- AGA
- TUV
- Kosha
- IMQ
- NSF
- VDE



# HOW TO USE THIS CATALOGUE

This catalogue is a comprehensive list of Parker FCDE products. It will help to identify appropriate valves and coils and enable the user to generate ordering numbers. The catalogue is intended for use by Parker Sales personnel with the aim to select the most suitable solenoid valves for customers.

This catalogue is split by product family. You will find a summary page at the beginning of each valve section. For ease of use, each valve section is divided by application.

On the first page of each Application section, you will find an overview of the products within and their technical characteristics, to guide you to the relevant page (example below):

## SECTION SUMMARY PAGE

**2 WAY VALVES**

VALVES FOR DRY OR LUBRICATED AIR, NEUTRAL GASES AND LIQUIDS

**2/2**

Actuation	Body	Function	Part Size	Orifice (mm)	Flow Factor (Kv/Cv)	Mounting	Max. Fluid Temp. (°C)	Page Number	Page Count			
Direct Operated	Brass/Pipe mounting	Normally Closed	1/8"	1.2 to 3	4.5	70	140	26	32			
			1/4"	1.2 to 6	13	100	140	26	32			
		Normally Open	3/8"	4 to 6	12	10	120	-	36	40		
			1/2"	8.5 to 11	36	4	120	-	36	40		
MagniM1	Brass/Pipe mounting	Normally Open	1/8"	2.5	2.5	20	140	-	40	40		
			1/4"	1.5 to 3	4	40	140	38	40			
		Control by Electric Input	1/4"	3 to 5	11	20	100	-	40	40		
			5 mm	1.5 to 3	4.5	100	120	-	42	42		
		Normally Open	3/8"	13 to 15	65	20	140	48	48	48		
			1/2"	13 to 15	65	20	140	48	48	48		
		Normally Closed	3/8"	15 to 20	100	20	140	48	50	50		
			1/2"	15 to 20	100	20	140	48	50	50		
		Pilot Operated	Brass/Pipe mounting	Normally Closed	1/4"	8 to 12	36	40	120	-	56	60
					3/8"	11 to 13	50	40	120	54	58	60
1/2"	11 to 15				60	40	120	54	60	60		
3/4"	15 to 20				135	40	120	54	62	64		
1"	18 to 28				270	16	120	54	64	66		
1 1/2"	40				405	16	120	-	66	66		
Normally Open	2"				40	540	16	120	-	66	66	
	1/4"				8	36	40	120	-	70	70	
3/8"	11 to 13				50	40	120	-	68	70		
1/2"	13 to 15				60	40	140	68	70	70		
3/4"	15 to 20			135	40	120	68	72	72			
1"	25 to 40			420	16	120	68	72	72			
1 1/4"	28			270	16	120	-	72	72			
1 1/2"	40			420	12	100	-	72	72			
Control by Electric Input	2"			40	540	12	120	-	72	72		
	1/4"			12	36	12	100	-	74	74		
3/8"	12			45	12	100	-	74	74			
1/2"	12			50	12	100	-	74	74			
3/4"	18			100	12	100	-	74	74			
Brass/Sub-base mounting	1"			18	110	12	100	-	74	74		
	14 mm	14	45	40	140	-	74	74				
Normally Open	14 mm	14	45	40	120	-	74	74				

Product family

Application

Number of ways / positions

Actuation

Applicable Fluids

Actuation, body and function

Body

Mounting

Function

Technical features

Related page

For further technical information regarding Actuation, Body and Function, please refer to the technical information section at the end of the catalogue.



Applicable **Markets** for this valve category

Applicable **Approvals** within this page

**Quick selection table** with Min/Max values for all valves on the page

## SECTION PRODUCT PAGE

**2 WAY VALVES**  
**2 1/2" MAGNALIFT**  
**HOT WATER AND STEAM VALVES**

**BRASS**  
**PIPE MOUNTING**  
**NORMALLY CLOSED**

Part size	Orifice ID	Flow Factors	Operating Pressure Differential (bar)	Fluid Temp. (°C)	Seat Seal	Parker LUCIFER® Valves		Coil Group	Dwg. No.							
						Valve Ref.	Coil Ref.									
3/8"	15	65 3.9	0	10	-0	100	EPDM	22161303	2995	481805	8	2.0	3732			
	15	65 3.9	0	4	4	0	140	EPDM	22161303	4270	481000	14	2.0	3732		
	15	65 3.9	4000	0	10	10	-10	100	FRM	22161330	2995	481805	8	2.1	3732	
1/2"	15	65 3.9	4000	0	10	10	-10	120	FRM	22161330	-	492190	11	9	2.1	3732
	15	65 3.9	0	10	-0	100	EPDM	22161330	2995	481805	8	2.0	3732			
	15	65 3.9	0	10	-0	120	EPDM	22161303	4270	481000	8	2.0	3732			
3/4"	15	65 3.9	0	10	-0	100	EPDM	22161303	4270	481000	8	2.0	3732			
	15	80 4.8	0	10	-0	100	EPDM	22161603	2995	481805	8	2.0	3444			
	15	80 4.8	0	10	-0	120	EPDM	22161603	4270	481000	8	2.0	3444			
1"	15	80 4.8	0	10	-0	100	EPDM	22161703	2995	481805	8	2.0	3445			
	15	80 4.8	0	10	-0	120	EPDM	22161703	4270	481000	8	2.0	3445			
	15	80 4.8	0	10	10	0	140	EPDM	22161703	4700	480200	14	3.4	3445		

**Notes:**  
\* Valves with model number ending in 30 or 31 are mainly equipped with electrical parts for explosion proof applications or with standard DCS.

For this page	Part size	Orifice (mm)	Kv (l/min)	MOPD (bar)	Fluid Temp (°C)	Amb Temp (°C)
From	3/8"	15	65	4	-10	-10
To	1"	15	80	10	140	50

Drawing 3732

Drawing 3444

Drawing 3445

**Ordering information**

**ISO Symbol**

A choice of **Coil Groups** compatible with the selected valve.

**Dimensional 2D\* and 3D drawings**

\* 2D drawing shown always corresponds to the standard coil.



## HOW TO SELECT A VALVE

Once you are in the selected family **1** and application **2**.

The table is designed to help you navigate to the products matching your criteria.

First decide the actuation **3**, then move across the table selecting your body material **4**, function **5** and technical requirements **6**.

After you have found products fitting within your specification, please go to the corresponding page number in the final column **7**, here you will find a selection of products that match your criteria.

**1** SELECT PRODUCT FAMILY

**2** SELECT APPLICATION

**3** SELECT ACTUATION

**4** SELECT BODY

**5** SELECT FUNCTION

**6** SELECT TECHNICAL DATA

**7** SELECT CORRESPONDING PAGE

1

2 WAY VALVES

VALVES FOR DRY OR LUBRICATED AIR, NEUTRAL GASES AND LIQUIDS

2



2/2

Actuation	Body	Function	Port Size	Orifice (mm)	Flow Factor Kv(l/min)	MOPD (bar)	Max Fluid Temp. (°C)	Page Parker Valves	Page Parker JIC/CFR Valves		
Direct Operated	Brass/Pipe mounting	Normally Closed	1/8"	1.2 to 3	4.5	70	140	28	32		
			1/4"	1.2 to 5	13	100	140	30	32		
			3/8"	4 to 6	12	10	120	-	36		
			1/2"	8.5 to 11	36	4	120	-	36		
			1/8"	2.5	3.5	30	140	-	40		
	Magnalift	Brass/Pipe mounting	Normally Open	1/4"	1.5 to 3	4	40	140	38	40	
				Control by Electric Impulse	1/4"	3 to 5	11	20	100	-	40
				Normally Closed	5 mm	1.5 to 3	4.5	100	130	-	42
				Normally Open	5 mm	1.5	1.5	20	120	-	44
				Normally Closed	3/8"	13 to 15	65	20	140	46	48
Pilot Operated		Brass/Pipe mounting	Normally Open	1/2"	13 to 15	65	20	140	46	48	
				3/4"	15 to 20	100	20	140	46	50	
				1"	15 to 25	170	20	140	46	52	
				1/4"	8 to 12	40	16	120	-	64	
				3/8"	11 to 13	50	16	120	54	66	
	Pilot Operated	Brass/Pipe mounting	Normally Open	1/2"	11 to 15	40	16	120	54	66	
				3/4"	15 to 20	135	16	120	54	66	
				1"	18 to 28	270	16	120	54	66	
				1 1/2"	40	425	16	120	-	70	
				2"	40	540	16	120	-	70	
Pilot Operated		Brass/Pipe mounting	Normally Open	1/4"	8	36	40	140	-	70	
				3/8"	11 to 13	50	40	140	68	70	
				1/2"	13 to 15	60	40	140	68	70	
				3/4"	15 to 20	135	40	120	68	72	
				1"	25 to 40	420	16	120	68	72	
	Pilot Operated	Brass/Pipe mounting	Normally Open	1 1/4"	28	270	16	120	-	72	
				1 1/2"	40	420	12	100	-	72	
				2"	40	540	12	120	-	72	
				Control by Electric Impulse	1/4"	12	32	12	100	-	74
				3/8"	12	45	12	100	-	74	
Brass/Sub-base mounting		Normally Open	1/2"	12	50	12	100	-	74		
			3/4"	18	100	12	100	-	74		
			1"	18	110	12	100	-	74		
			Normally Closed	14 mm	14	45	40	140	-	76	
			Normally Open	14 mm	14	46	40	120	-	76	



# HOW TO ORDER

## BETWEEN TWO PRODUCT RANGES

### 7 SELECT CORRESPONDING

#### Parker [Blue Table]

**2 WAY VALVES**

**2/2** VALVES FOR DRY OR LUBRICATED AIR, NEUTRAL GASES AND LIQUIDS  
DIRECT OPERATED

BRASS  
PIPE MOUNTING  
NORMALLY CLOSED

Part size	Orifice Ø	Flow factors			Operating Pressure Differential			Fluid Temp.		Seat Seal	Parker Valves			Power		Coil Group	Dwg. No.
		Kv	Kv	Qn	Min	Max	DC	Max	Min		Max	Valve Order Number	Valve Type	Coil Type	AC W		
1/8"	2.5	3.3	0.20	-	0	-	5	-10	140	FKM	363380	PM146FV	ZB12	-	12	20.1/20.2	034
	3	4.5	0.27	-	0	7	-	-10	140	FKM	363390	PM146HV	ZB09	9	-	20.1/20.2	034
	3	4.5	0.27	-	0	-	2	-10	140	FKM	363390	PM146HV	ZB12	-	12	20.1/20.2	034
	2.5	2.2	0.13	-	0	10	-	-10	140	FKM	398006	N74.4WV	WB4.5 230/0-60	4.5	-	1.3	065
	2.5	2.2	0.13	-	0	10	-	-10	140	FKM	398007	N74.4WV	WB4.5 240/0-60	4.5	-	1.3	065
	2.5	2.2	0.13	-	0	-	4	-10	140	FKM	398008	N74.4WV	WB5.0 120C	-	5	1.3	065
	2.5	2.2	0.13	-	0	-	4	-10	140	FKM	398010	N74.4WV	WB5.0 240C	-	5	1.3	065
	2.5	2.2	0.13	-	0	19	-	-10	140	FKM	398011	N74.4WV	WB5.0 240C	-	5	1.3	065

- Designed for Industrial Automation applications
- ATEX applications only if indicated

• Please order:  
**Valve + Coil**

#### Order Separately

1

**VALVE**

Valve order example:  
**363380**

2

**COIL**

Coil order example:  
**304002**

For more details, see page 20:  
**How to Order Parker Valves**

**CAUTION:** For N74, N79, 131.4, 131, 175, 180, 161 valves series, the valve order number indicates assembled valve and coil for the voltage shown.

**IMPORTANT:** For assembled solenoid valves, please consult your local sales office.



ENDING PAGE

### Parker Lucifer® [Orange Table]

2 WAY VALVES																
2/2 VALVES FOR DRY OR LUBRICATED AIR, NEUTRAL GASES AND LIQUIDS DIRECT OPERATED																
BRASS PIPE MOUNTING NORMALLY CLOSED																
Port size	Orifice Ø	Flow factors			Operating Pressure Differential		Fluid Temp.		Seat Seal	Parker LUCIFER® Valves			Power		Coil Group	Dwg. No.
		Kv	Kv1	Qn	AC	DC	Min	Max		Valve Ref.	Housing Ref.	Coil Ref.	AC W	DC W		
4	7.5	0.45	480	0	10	4	-10	100	FKM	121K3206	2995	481865	8	9	2.0	3551
4	7.5	0.45	480	0	10	5	-10	120	FKM	121K3206	4270	481000	8	8	2.0	3551
4	7.5	0.45	480	0	10	10	-10	120	FKM	121K3206	4270	486265	14	14	2.0	3551
5	11	0.66	750	0	7	2	-10	100	FKM	121K3106	2995	481865	8	9	2.0	3551
5	11	0.66	750	0	7	2.8	-10	120	FKM	121K3106	4270	481000	8	8	2.0	3551
5	11	0.66	750	0	7	5	-10	120	FKM	121K3106	4270	486265	14	14	2.0	3551
6	12	0.72	1100	0	5	1.1	-10	100	FKM	121K3306	2995	481865	8	9	2.0/14.2	3551
6	12	0.72	1100	0	5	1.5	-10	120	FKM	121K3306	4270	486265	14	14	2.0	3551

- Thanks to the modular concept, a wide range of electrical parts can be used including ATEX, IECEx, IP67, H class, reduced power, UL/VDE approved
- For demanding applications in reliability, performance, quality
- High quality materials and execution
- **Please order:**  
Valve + Housing + Coil

One Order

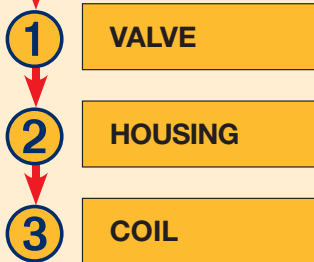

For more details, see page 22:

How to Order Parker Lucifer® Solenoid Valves

Valve and coil order example:

1 - 2 - 3  
 121K3206 - 2995 - 481865A2  
 Valve Reference      Housing      Coil and Voltage Code

# HOW TO ORDER PARKER VALVES

## A PARKER SOLENOID VALVE IS COMPOSED OF 2 ELEMENTS:

The Valve ① and the Coil ②

① Use the valve order number (6 digits) to order the valve.

Valve Order Number
363380
363390
363390

Valve order N° example:  
363380

For a given valve, several coil types are being suggested.

For a wider choice, the selected valve is also compatible with every other coil from the same coil group.

**2 WAY VALVES**

**2/2** VALVES FOR DRY OR LUBRICATED AIR, NEUTRAL GASES AND LIQUIDS  
DIRECT OPERATED

**BRASS PIPE MOUNTING**

**NORMALLY CLOSED**



Port size	Orifice Ø	Flow factors	Operating Pressure Differential	Fluid Temp.	Seal	Parker Valves			Power	Coil Group	Dwg. No.							
						Valve Order Number	Valve Type	Coil Type										
1/8"	2.5	3.3	0.20	-	0	7	-	-	10	140	FKM	363380	PM146FV	ZB12	-	12	20.1/20.2	034
	3	4.5	0.27	-	0	7	-	-	10	140	FKM	363390	PM146HV	ZB09	9	-	20.1/20.2	034
	3	4.5	0.27	-	0	2	-	-	10	140	FKM	363390	PM146HV	ZB12	-	12	20.1/20.2	034
	2.5	2.2	0.13	-	0	10	-	-	10	140	FKM	388006	N74.4WV	WB4.5 23510-60	4.5	-	1.3	065
	2.5	2.2	0.13	-	0	10	-	-	10	140	FKM	388007	N74.4WV	WB4.5 24510-60	4.5	-	1.3	065
	2.5	2.2	0.13	-	0	4	-	-	10	140	FKM	388008	N74.4WV	WB5.0 120C	-	5	1.3	065
1/4"	2.5	2.2	0.13	-	0	4	-	-	10	140	FKM	388010	N74.4WV	WB5.0 240C	-	5	1.3	065
	2.5	2.2	0.13	-	0	19	-	-	10	140	FKM	388012	N74.4WV	WB8.0 23510-60	8	-	1.3	065
	3	4.5	0.27	-	0	7	-	-	10	140	FKM	363444	PM146YV	ZB09	9	-	20.1/20.2	035
	3	4.5	0.27	-	0	2	-	-	10	140	FKM	363444	PM146YV	ZB12	-	12	20.1/20.2	035
	4.5	9	0.53	-	0	6	-	-	10	140	FKM	363457	PM146.3KV	ZB14	14	-	20.2	035
	4.5	9	0.53	-	0	2.5	-	-	10	140	FKM	363457	PM146.3KV	ZB16	-	16	20.2	035
6	13	0.75	-	0	6	-	-	10	140	FKM	363467	PM146.3BV	ZB14	14	-	20.2	035	
	6	13	0.75	-	0	1	-	-	10	140	FKM	363467	PM146.3BV	ZB16	-	16	20.2	035

**Notes:**  
1. Ordering number is for an assembled valve and coil, with the voltage shown.



30

Parker Hannifin Corporation  
Fluid Control Division Europe  
General Catalogue FCDE/0110/UK/V2.0



20

Parker Hannifin Corporation  
Fluid Control Division Europe  
General Catalogue FCDE/0110/UK/V2.0

# HOW TO ORDER PARKER COILS

**2** Use the coil order number (6 digits) to order the coils

Choose the coil and use the 6 digits order number to order.

VAC/Hz	Order Number
ZB09 24/50-60	<b>304004</b>
ZB09 12/50-60	<b>304002</b>
ZB09 230/50-60	<b>304012</b>

Coil order N° example:  
**304002**

**COILS**

**COIL GROUP**  
**20.1** COILS FOR DIN PLUG CONNECTION

**ZB COIL SERIES**

These coils can be mounted with every Parker solenoid valves corresponding to the specified Coil Group. See column "Coil Group" within valve pages.

Coil manufactured with H class copper wire, moulded in thermoplastic material polyester with 30% glass fiber. IP65 protection rate with EN 175301-803:2006-A. Three pin connector. This coil conforms to the IEC/GENELEC safety standards and complies with European low-voltage directive. For UL recognized version: UL file MH19410. DIN plug connector to be ordered separately (see coil accessories section).



Specification	Standard	UL recognized version				
Reference (without DIN plug)	ZB09/ZB12	ZB09 for AC only				
Coil Group	20.1					
Degree of protection	IP65 according to IEC / EN 60529 standards (with DIN plug and gasket)					
Class of insulation	F 155°C					
Electrical connection	The coil is connected with a 2 P + E plug according to EN 175301-803 - type A					
Ambient temperature	-10°C to +50°C The application is limited also by the temperature range of the valve.					
Elect. Power	DC P (cold) 20°C	12 W				
	AC P (cold) 20°C	9 W				
Attraction coil		25 VA				
Weight	130 g					
Voltages "Un"	VAC/Hz	Order Number	VDC	Order Number	VAC/Hz	Order Number
-10% to +10% of Un for AC	ZB09 24/50-60	<b>304004</b>	ZB12 12DC	<b>304018</b>	ZB09 24/60	<b>304048</b>
-5 % to + 10 % for Un DC.	ZB09 12/50-60	<b>304002</b>	ZB12 24DC	<b>304020</b>	ZB09 110-120/60	<b>304011</b>
	ZB09 230/50-60	<b>304012</b>	ZB12 110DC	<b>304022</b>	ZB09 208-240/60	<b>304051</b>
	ZB09 110/50-60	<b>304010</b>	ZB12 48VDC	<b>304021</b>		
	ZB09 100/50-60	<b>304009</b>				
	ZB09 240/50-60	<b>304014</b>				
	ZB09 48/50-60	<b>304008</b>				
	ZB09 110-120/60	<b>304011</b>				
	ZB09 380/50-60	<b>304016</b>				

**To Order a Coil:** Use 6 digits ordering number - Code Example: ZB09 24/50-60 = **304004**  
More voltage possibilities can be found in the table of voltage codes at the end of the coil section.

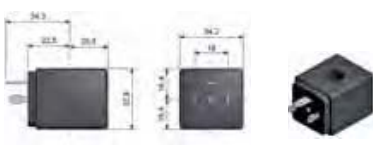

**Parker** 460 Parker Hannifin Corporation  
Fluid Control Division Europe  
General Catalogue FCDE/0110/UK/V2.0

Coil section at the end of the catalogue

**IMPORTANT:** For assembled solenoid valves, please consult your local sales office.



# HOW TO ORDER PARKER LUCIFER® SOLENOID VALVES

## A PARKER LUCIFER® SOLENOID VALVE IS COMPOSED OF 3 ELEMENTS:

The Valve **1** + Housing **2** + Coil **3**

1. Choose the valve reference
2. Choose the housing
3. Choose the coil

### 1 Choose the Valve Reference.

Valve Ref.
121K3206
121K3206
121K3206

### 2 Select the housing depending on the protection level (IP 44 to IP 67 found in the coil section)

Housing Ref.
2995
4270
4270

For a given valve, several coil types are being suggested.

For a wider choice, the selected valve is also compatible with every other coil from the same coil group.

2 WAY VALVES																	
2/2 VALVES FOR DRY OR LUBRICATED AIR, NEUTRAL GASES AND LIQUIDS DIRECT OPERATED																	
BRASS PIPE MOUNTING																	
NORMALLY CLOSED																	
Part size	Orifice Ø	Flow factors			Operating Pressure Differential Max(MDPO)		Fluid Temp.		Seat Seal	Parker LUCIFER® Valves			Power	Coil Group	Dwg. No.		
		Kv	Kv	Qn	AC	DC	Min	Max		Valve Ref.	Housing Ref.	Coil Ref.					
BSP	mm	mm	mm	mm	bar	bar	°C	°C				AC W	DC W				
3/8"	4	7.5	0.45	480	0	10	4	-10	100	FKM	121K3206	2995	481895	8	9	2.0	3551
	4	7.5	0.45	480	0	10	5	-10	120	FKM	121K3206	4270	481000	8	8	2.0	3551
	5	7.5	0.45	480	0	10	10	-10	100	FKM	121K3206	4270	486285	14	14	2.0	3551
	5	11	0.66	750	0	7	2	-10	100	FKM	121K3106	2995	481895	8	9	2.0	3551
	5	11	0.66	750	0	7	5	-10	120	FKM	121K3106	4270	481000	8	8	2.0	3551
	5	11	0.66	750	0	7	5	-10	120	FKM	121K3106	4270	486285	14	14	2.0	3551
1/2"	6	12	0.72	1100	0	5	1.1	-10	100	FKM	121K3306	2995	481895	8	9	2.0/14.2	3551
	6	12	0.72	1100	0	5	1.5	-10	120	FKM	121K3306	4270	481000	8	8	2.0/14.2	3551
	6	12	0.72	1100	0	5	3	-10	120	FKM	121K3306	4270	486285	14	14	2.0/14.2	3551
	8.5	25	1.5	1600	0	1.1	0.5	-10	100	FKM	E121K46	2995	481895	8	9	2.0	3427
	8.5	25	1.5	1600	0	2.2	0.5	-10	120	FKM	E121K46	4270	481000	8	8	2.0	3427
	8.5	25	1.5	1600	0	4	1.2	-10	120	FKM	E121K46	4270	486285	14	14	2.0	3427
1/2"	11	36	2.16	2500	0	0.7	0.3	-10	100	FKM	E121K45	2995	481895	8	9	2.0	3427
	11	36	2.16	2500	0	1.2	0.35	-10	120	FKM	E121K45	4270	481000	8	8	2.0	3427
	11	36	2.16	2500	0	2.5	0.7	-10	120	FKM	E121K45	4270	486285	14	14	2.0	3427

Notes:  
1. Valve compatible with water only up to 40°C  
2. With manual override



36

Parker Hannifin Corporation  
Fluid Control Division Europe  
General Catalogue FCDE/0110/UK/V2.0



Parker Lucifer® coils are available in many different voltages.  
Choose the one you need by putting the voltage code at the end of your ordering number.

**3** Choose the coil and voltage code.

Coil Ref.  
**481865**

VAC/Hz	Code
24/50	A2
48/50	A4
110/50	A5
220-230/50	3D

**Valve and coil order example:**

1 - 2 - 3

121K3206 - 2995 - 481865A2

Valve Reference      Housing      Coil and Voltage Code

**COILS**

**COIL GROUP**  
**2.0/2.1** COILS FOR DIN PLUG CONNECTION

**COILS 32 mm**

These coils can be mounted with every Parker solenoid valves corresponding to the specified Coil Group.  
See column "Coil Group" within valve pages.

This is an encapsulated assembly comprising a coil, integral magnetic path and snap-on plug connection.

The synthetic material encapsulation provides an effective compact housing, offering full protection against dust, oil, water, etc. Ease of mounting in confined space - offers shock and corrosion protection - simplifies conversion of existing equipment to other requirements, etc.  
Coils conform to the IEC/ENEC safety standards and complies with European low-voltage directive.



Specification	Standard	Double frequency
Ref. (without DIN plug)	481865	483510
Ref. (with DIN plug)	482725	482635
Coil Group	2.0 / 2.1	
Degree of protection	IP65 according to IEC / EN 60529 standards (with DIN plug).	
Class of insulation	F 155°C	
Electrical connection	The coil is connected with a 2 P + E plug according to EN 175301-803 type A	
Ambient temperature	-40°C to +50°C The application is limited also by the temperature range of the valve.	
Elect. Power	9 W	-
DC P (cold, 20°C)	12 W	-
AC P (holding)	8 W	9 W
Attraction cold	26 VA (9 W)	32 VA (10 W)
Weight	130 g (without plug)	
Voltages "Un"	VAC/Hz	Code
-10% to +10% of the Un	24/50	A2
	48/50	A4
	110/50	A5
	220-230/50	3D
	VDC	Code
	24	C2
	48	C4
	110-115/50, 120/60	C5
	220-240/50, 240/60	SS
		SB

To Order a Coil choose Coil Ref + Voltage Code, example: 481865 for 24 VDC + 481865C2  
More voltage possibilities can be found in the table of voltage codes at the end of the coil section.

These coils must be used with suitable housings, see example below:

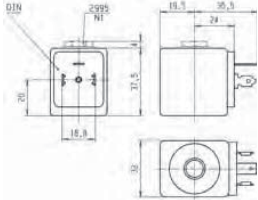
The coil assembly kit Ref. 2995 corresponds to the "housing" of Lucifer® valve numbering system (Valve - housing - coil/voltage). It is composed of a nameplate giving details of the valve type, a round washer and a nut to ensure the fixing between 32 mm coil and the valve.

446

Parker Hannifin Corporation  
Fluid Control Division Europe  
General Catalogue FCDE/0110/UK/V2.0

**IMPORTANT:** Valve, Housing or Coil can be ordered separately for use as a replacement or spare part.

# HOW TO USE COIL GROUPS

## WITHIN A VALVE PAGE

One of Parker's strengths is the modularity, adaptability and flexibility of our products. When you select a solenoid valve, the coils displayed in the table have been chosen as they will fulfill the majority of application requirements.

Parker LUCIFER® Valves		
Valve Ref.	Housing Ref.	Coil Ref.
121K3206	2995	481865
121K3206	4270	481000
121K3206	4270	486265

However, in some specific cases, you will need special features that will lead you to choose another coil.

Groups have been created in order to facilitate the selection of a compatible coil with the chosen valve.

Coil Group
2.0
2.0
2.0

### Example:

The valve 121K3206 is proposed with the coil 481865 but you can also choose any coil from the group 2.0.

**2 WAY VALVES**

**2/2** VALVES FOR DRY OR LUBRICATED AIR, NEUTRAL GASES AND LIQUIDS  
DIRECT OPERATED

**BRASS PIPE MOUNTING**

**NORMALLY CLOSED**

Port size	Orifice Ø	Flow factors	Operating Pressure Differential	Fluid Temp.	Seat Seal	Parker LUCIFER® Valves			Power		Coil Group	Dwg. No.		
						Valve Ref.	Housing Ref.	Coil Ref.	AC W	DC W				
3/8"	4	7.5 0.45	0 10 4	-10 100	FKM	121K3206	2995	481865	8	9	2.0	3551		
	4	7.5 0.45	480 0 10	-10 120	FKM	121K3206	4270	481000	8	8	2.0	3551		
	4	7.5 0.45	480 0 10	10 -10	FKM	121K3206	4270	486265	14	14	2.0	3551		
	5	11 0.66	750 0 7	2 -10	100	FKM	121K3106	2995	481865	8	9	2.0	3551	
	5	11 0.66	750 0 7	2.8 -10	120	FKM	121K3106	4270	481000	8	8	2.0	3551	
	5	11 0.66	750 0 7	5 -10	120	FKM	121K3106	4270	486265	14	14	2.0	3551	
	6	12 0.72	1100 0 5	1.1 -10	100	FKM	121K3306	2995	481865	9	9	2.0/14.2	3551	
	6	12 0.72	1100 0 5	1.5 -10	120	FKM	121K3306	4270	481000	8	8	2.0/14.2	3551	
	6	12 0.72	1100 0 5	3 -10	120	FKM	121K3306	4270	486265	14	14	2.0/14.2	3551	
	1/2"	8.5	25 1.5	1600 0 1.1	0.5 -10	100	FKM	E121K46	2995	481865	8	9	2.0	3427
		8.5	25 1.5	1600 0 2.2	0.5 -10	120	FKM	E121K46	4270	481000	8	8	2.0	3427
		11	36 2.16	2500 0 0.7	0.3 -10	100	FKM	E121K46	4270	486265	14	14	2.0	3427
11		36 2.16	2500 0 1.2	0.35 -10	120	FKM	E121K46	2995	481865	8	9	2.0	3427	
11		36 2.16	2500 0 1.2	0.35 -10	120	FKM	E121K46	4270	481000	8	8	2.0	3427	
11		36 2.16	2500 0 2.5	0.7 -10	120	FKM	E121K46	4270	486265	14	14	2.0	3427	

**Notes:**  
1. Valve compatible with water only up to 40°C  
2. With manual lever

36

Parker Hannifin Corporation  
Fluid Control Division Europe  
General Catalogue FCDE/0110/UK/V2.0

It is also possible to choose the coil first and then select the valve using coil groups.

# HOW TO USE COIL GROUPS

## WITHIN A COIL PAGE

The coil section is at the end of the catalogue and displays the specifications of each coil, along with the reference number, class of insulation, ambient temperature, electrical power and weight.

**2.0 / 2.1**

As indicated before, the valve 121K3206 is proposed with coil 481865 but is also compatible with the 2.0 coil group. This means the coil 482725 is also compatible with the chosen valve as it is within this group.

When referring to the coil section you will find the coil group for each coil. This allows you to discover which other coils are compatible with the valve you have chosen.

COILS

COIL GROUP

2.0/2.1

COILS FOR  
DIN PLUG CONNECTION

**COILS 32 mm**

These coils can be mounted with every Parker solenoid valves corresponding to the specified Coil Group. See column "Coil Group" within valve pages.

This is an encapsulated assembly comprising a coil, integral magnetic iron path and snap-on plug connection.

The synthetic material encapsulation provides an effective compact housing, offering full protection against dust, oil, water, etc. Ease of mounting in confined space - offers shock and corrosion protection - simplifies conversion of existing equipment to other requirements, etc.

Coils conform to the IEC/CENELEC safety standards and complies with European low-voltage directive.

Specification	Standard	Double frequency				
Ref. (without DIN plug)	481865	483510				
Ref. (with DIN plug)	482725	482635				
Coil Group	2.0 / 2.1					
Degree of protection	IP65 according to IEC / EN 60529 standards (with DIN plug).					
Class of insulation	F 155°C					
Electrical connection	The coil is connected with a 2 P + E plug according to EN 175301-803 type A					
Ambient temperature	-40°C to +50°C <small>The application is limited also by the temperature range of the valve.</small>					
Elect. Power	DC Pn (hot)	9 W				
	P (cold) 20°C	12 W				
AC	Pn (holding)	9 W				
	Attraction cold	26 VA (9 W)      32 VA (10 W)				
Weight	130 g (without plug)					
Voltages "Un"	VAC/Hz	Code	VDC	Code	VAC/Hz	Code
-10% to +10% of the Un	24/50	A2	24	C2	24/50, 24/60	P0
	48/50	A4	48	C4	48/50, 48/60	S4
	110/50	A5	110	C5	110-115/50, 120/60	S5
	220-230/50	S0			220-240/50, 240/60	S6

To Order a Coil choose Coil Ref + Voltage Code, example: 481865 for 24 VDC = 481865C2  
More voltage possibilities can be found in the table of voltage codes at the end of the coil section.

These coils must be used with suitable housings, see example below:

The coil assembly kit Ref. 2995 corresponds to the "housing" of Lucifer® valve numbering system (Valve - housing - coil/voltage). It is composed of a nameplate giving details of the valve type, a round washer and a nut to ensure the fixing between 32 mm coil and the valve.

446

Parker Hannifin Corporation  
Fluid Control Division Europe  
General Catalogue FCDE/0110/UK/V2.0

25

Parker Hannifin Corporation  
Fluid Control Division Europe  
General Catalogue FCDE/0110/UK/V2.0

Tel: +45 63 12 83 00 | Email: ps@hymatik.com | www.hymatik.com | Hvidkaervej 27a, DK-5250 Odense SV, Denmark

## 2 WAY VALVES

## 2 WAY VALVES



# VALVES FOR DRY OR LUBRICATED AIR, NEUTRAL GASES AND LIQUIDS



# 2/2

Actuation	Body	Function	Port Size	Orifice (mm)	Flow Factor Kv(l/min)	MOPD (bar)	Max Fluid Temp. (°C)	Page Parker Valves	Page Parker LUCIFER® Valves	
Direct Operated	Brass/Pipe mounting	Normally Closed	1/8"	1.2 to 3	4.5	70	140	28	32	
			1/4"	1.2 to 5	13	100	140	30	32	
			3/8"	4 to 6	12	10	120	-	36	
			1/2"	8.5 to 11	36	4	120	-	36	
		Normally Open	1/8"	2.5	3.5	30	140	-	40	
			1/4"	1.5 to 3	4	40	140	38	40	
			Control by Electric Impulse	1/4"	3 to 5	11	20	100	-	40
		Brass/Sub-base mounting	Normally Closed	5 mm	1.5 to 3	4.5	100	130	-	42
			Normally Open	5 mm	1.5	1.5	20	120	-	44
		Magnalift	Brass/Pipe mounting	Normally Closed	3/8"	13 to 15	65	20	140	46
1/2"	13 to 15				65	20	140	46	48	
3/4"	15 to 20				100	20	140	46	50	
1"	15 to 25				170	20	140	46	52	
Pilot Operated	Brass/Pipe mounting	Normally Closed	1/4"	8 to 12	36	40	120	-	56	
			3/8"	11 to 13	50	40	120	54	58	
			1/2"	11 to 15	60	40	120	54	60	
			3/4"	15 to 20	135	40	120	54	62	
			1"	18 to 28	270	16	120	54	64	
			1 1/2"	40	425	16	120	-	66	
			2"	40	540	16	120	-	66	
			Normally Open	1/4"	8	36	40	140	-	70
				3/8"	11 to 13	50	40	140	68	70
				1/2"	13 to 15	60	40	140	68	70
				3/4"	15 to 20	135	40	120	68	72
		1"		25 to 40	420	16	120	68	72	
		1 1/4"		28	270	16	120	-	72	
		1 1/2"		40	420	12	100	-	72	
		Control by Electric Impulse	2"	40	540	12	120	-	72	
			1/4"	12	32	12	100	-	74	
			3/8"	12	45	12	100	-	74	
			1/2"	12	50	12	100	-	74	
			3/4"	18	100	12	100	-	74	
			1"	18	110	12	100	-	74	
		Brass/Sub-base mounting	Normally Closed	14 mm	14	45	40	140	-	76
			Normally Open	14 mm	14	46	40	120	-	76



## 2 WAY VALVES

# 2/2

## VALVES FOR DRY OR LUBRICATED AIR, NEUTRAL GASES AND LIQUIDS DIRECT OPERATED



Commercial Equipment



Industrial Equipment



Heating Systems

### BRASS PIPE MOUNTING

#### NORMALLY CLOSED

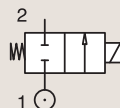

Port size	Orifice Ø	Flow factors			Operating Pressure Differential			Fluid Temp.		Seat Seal	Parker Valves			Power		Coil Group	Dwg. No.
		Kv	KV	Qn	Min	Max(MOPD)	DC	Min	Max		Valve Order Number	Valve Type	Coil Type	AC W	DC W		
BSP	mm	l/min	m <sup>3</sup> /h	m <sup>3</sup> /h	bar	AC bar	DC bar	°C	°C								
1/8"	1.2	0.7	0.04	-	0	20	-	-10	140	FKM	398018 <sub>1</sub>	N74.4IV	WB4.5 115/50-60	4.5	-	1.3	064
	1.5	1	0.06	-	0	20	-	-10	140	FKM	398017 <sub>1</sub>	N74.4AV	WB4.5 115/50-60	4.5	-	1.3	064
	1.5	1	0.06	-	0	20	-	-10	140	FKM	398014 <sub>1</sub>	N74.4AV	WB4.5 230/50-60	4.5	-	1.3	064
	1.5	1	0.06	-	0	20	-	-10	140	FKM	398030 <sub>1</sub>	N74.4AV	WB4.5 24/50-60	4.5	-	1.3	064
	1.5	1	0.06	-	0	-	10	-10	140	FKM	398034 <sub>1</sub>	N74.4AV	WB5.0 12DC	-	5	1.3	064
	1.5	1	0.06	-	0	-	10	-10	140	FKM	398016 <sub>1</sub>	N74.4AV	WB5.0 24DC	-	5	1.3	064
	1.5	1	0.06	-	0	-	10	-10	140	FKM	398013 <sub>1</sub>	N74.4AVA.5	WB5.0 5.0 24DC	-	5	1.3	064
	1.5	1.5	0.09	-	0	20	-	-10	140	FKM	363378	PM146BV	ZB09	9	-	20.1/20.2	034
	1.5	1.5	0.09	-	0	-	18	-10	140	FKM	363378	PM146BV	ZB12	-	12	20.1/20.2	034
	2.5	2.2	0.13	-	0	10	-	-10	140	FKM	398026 <sub>1</sub>	N74.4FV	WB4.5 115/50-60	4.5	-	1.3	064
	2.5	2.2	0.13	-	0	10	-	-10	140	FKM	398003 <sub>1</sub>	N74.4FV	WB4.5 115/60	4.5	-	1.3	064
	2.5	2.2	0.13	-	0	10	-	-10	140	FKM	398000 <sub>1</sub>	N74.4FV	WB4.5 230/50-60	4.5	-	1.3	064
	2.5	2.2	0.13	-	0	10	-	-10	140	FKM	398024 <sub>1</sub>	N74.4FV	WB4.5 24/50-60	4.5	-	1.3	064
	2.5	2.2	0.13	-	0	10	-	-10	140	FKM	398001 <sub>1</sub>	N74.4FV	WB4.5 240/50-60	4.5	-	1.3	064
	2.5	2.2	0.13	-	0	-	4	-10	140	FKM	398052 <sub>1</sub>	N74.4FV	WB5.0 12DC	-	5	1.3	064
	2.5	2.2	0.13	-	0	-	4	-10	140	FKM	398022 <sub>1</sub>	N74.4FV	WB5.0 24DC	-	5	1.3	064
	2.5	3.3	0.20	-	0	10	-	-10	140	FKM	363380	PM146FV	ZB09	9	-	20.1/20.2	034

#### Notes:

1. Ordering number is for an assembled valve and coil, with the voltage shown.



## 2 WAY VALVES



For this page	Port size	Orifice (mm)	Kv (l/min)	MOPD (bar)	Fluid Temp (°C)	Amb Temp (°C)
From	1/8"	1.2	0.7	4	-10	-10
To	1/8"	2.5	3.3	20	140	50

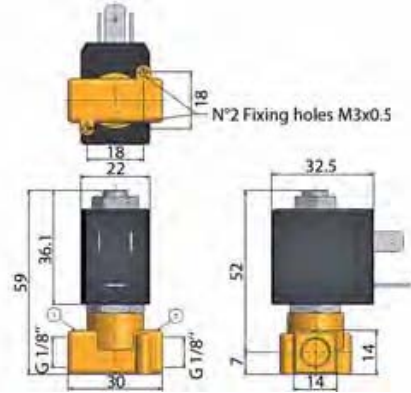

Drawing 064

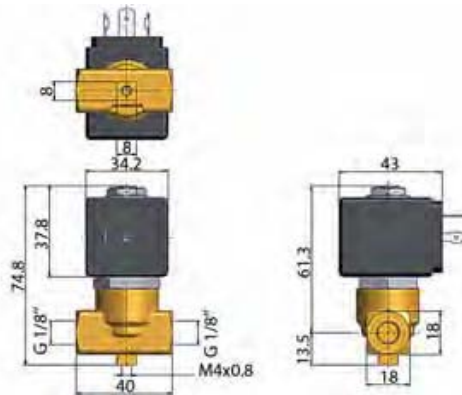

Drawing 034

## 2 WAY VALVES

# 2/2

### VALVES FOR DRY OR LUBRICATED AIR, NEUTRAL GASES AND LIQUIDS DIRECT OPERATED

BRASS

PIPE MOUNTING

**NORMALLY CLOSED**

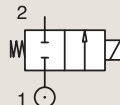

Port size	Orifice Ø	Flow factors			Operating Pressure Differential			Fluid Temp.		Seat Seal	Parker Valves			Power		Coil Group	Dwg. No.
		Kv l/min	KV m³/h	Qn m³/h	Min bar	Max(MOPD) bar	DC bar	Min °C	Max °C		Valve Order Number	Valve Type	Coil Type	AC W	DC W		
1/8"	2.5	3.3	0.20	-	0	-	5	-10	140	FKM	363380	PM146FV	ZB12	-	12	20.1/20.2	034
	3	4.5	0.27	-	0	7	-	-10	140	FKM	363390	PM146HV	ZB09	9	-	20.1/20.2	034
	3	4.5	0.27	-	0	-	2	-10	140	FKM	363390	PM146HV	ZB12	-	12	20.1/20.2	034
1/4"	2.5	2.2	0.13	-	0	10	-	-10	140	FKM	398006 <sub>1</sub>	N74.4WV	WB4.5 230/50-60	4.5	-	1.3	065
	2.5	2.2	0.13	-	0	10	-	-10	140	FKM	398007 <sub>1</sub>	N74.4WV	WB4.5 24/50-60	4.5	-	1.3	065
	2.5	2.2	0.13	-	0	-	4	-10	140	FKM	398008 <sub>1</sub>	N74.4WV	WB5.0 12DC	-	5	1.3	065
	2.5	2.2	0.13	-	0	-	4	-10	140	FKM	398010 <sub>1</sub>	N74.4WV	WB5.0 24DC	-	5	1.3	065
	2.5	2.2	0.13	-	0	19	-	-10	140	FKM	398012 <sub>1</sub>	N74.4WV	WB8.0 230/50-60	8	-	1.3	065
	3	4.5	0.27	-	0	7	-	-10	140	FKM	363444	PM146YV	ZB09	9	-	20.1/20.2	035
	3	4.5	0.27	-	0	-	2	-10	140	FKM	363444	PM146YV	ZB12	-	12	20.1/20.2	035
	4.5	9	0.53	-	0	6	-	-10	140	FKM	363457	PM146.3KV	ZB14	14	-	20.2	035
	4.5	9	0.53	-	0	-	2.5	-10	140	FKM	363457	PM146.3KV	ZB16	-	16	20.2	035
	6	13	0.75	-	0	6	-	-10	140	FKM	363467	PM146.3ABV	ZB14	14	-	20.2	035
6	13	0.75	-	0	-	1	-10	140	FKM	363467	PM146.3ABV	ZB16	-	16	20.2	035	

**Notes:**

1. Ordering number is for an assembled valve and coil, with the voltage shown.



## 2 WAY VALVES



For this page	Port size	Orifice (mm)	Kv (l/min)	MOPD (bar)	Fluid Temp (°C)	Amb Temp (°C)
From	1/8"	2.5	2.2	1	-10	-10
To	1/4"	6	13	19	140	50

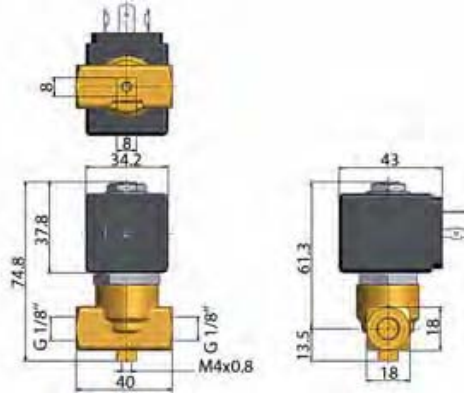

Drawing 034

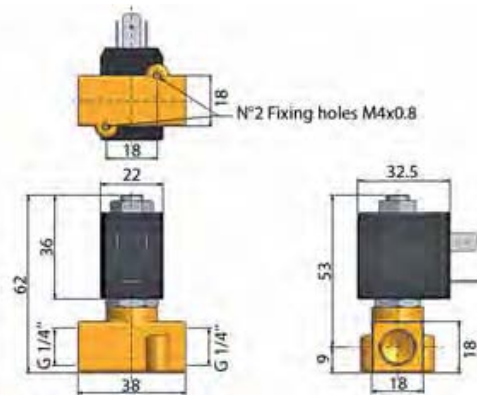

Drawing 065

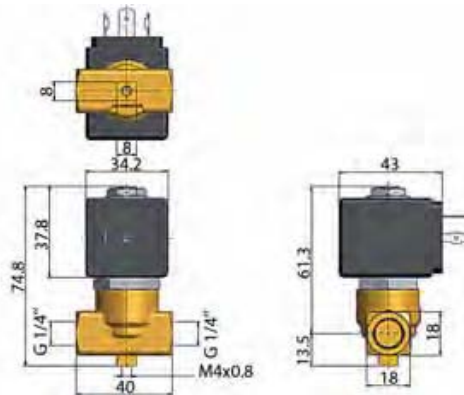

Drawing 035

## 2 WAY VALVES

# 2/2

### VALVES FOR DRY OR LUBRICATED AIR, NEUTRAL GASES AND LIQUIDS DIRECT OPERATED

BRASS

PIPE MOUNTING

**NORMALLY CLOSED**

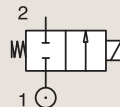

Port size	Orifice Ø	Flow factors			Operating Pressure Differential Max(MOPD)			Fluid Temp.		Seat Seal	Parker LUCIFER® Valves			IS	Power		Coil Group	Dwg. No.
		Kv	KV	Qn	Min	AC	DC	Min	Max		Valve Ref.	Housing Ref.	Coil Ref.		AC W	DC W		
BSP	mm	l/min	m³/h	l/min	bar	bar	bar	°C	°C									
1/8"	1.5	0.9	0.05	70	0	20	12	-10	75	FKM	121M14	8993	481180	4	5	1.1	3382	
	1.5	0.9	0.05	70	0	20	4	-10	75	FKM	121M14	8993	488980	2	2.5	1.1	3382	
	1.5	1.5	0.09	80	0	60	25	-30	75	PCTFE	E121K14	2995	481865	8	9	2.0	3510	
	1.5	1.5	0.09	80	0	70	30	-30	75	PCTFE	E121K14	4270	481000	8	8	2.0	3510	
	1.5	1.5	0.09	80	0	70	55	-30	75	PCTFE	E121K14	4270	486265	14	14	2.0	3510	
	2	2	0.12	125	0	10	7	-10	75	FKM	121M13	8993	481180	4	5	1.1	3382	
	2	2	0.12	125	0	10	2.5	-10	75	FKM	121M13	8993	488980	2	2.5	1.1	3382	
	2.5	3.5	0.21	220	0	28	10	-30	100	Ruby	E121K23	2995	481865	8	9	2.0	3510	
	2.5	3.5	0.21	220	0	34	12	-30	130	Ruby	E121K23	4270	481000	8	8	2.0	3510	
	2.5	3.5	0.21	220	0	50	22	-30	120	Ruby	E121K23	4270	486265	14	14	2.0	3510	
	3	4.5	0.27	320	0	10	7	-10	100	FKM	121K1302	2995	481865	8	9	2.0	3510	
	3	4.5	0.27	320	0	10	8	-10	120	FKM	121K1302	4270	481000	8	8	2.0	3510	
3	4.5	0.27	320	0	10	10	-10	120	FKM	121K1302	4270	486265	14	14	2.0	3510		
1/4"	1.2	0.85	0.05	50	0	80	36	-30	100	Ruby	E121K65	2995	481865	8	9	2.0	3510	
	1.2	0.85	0.05	50	0	100	43	-30	130	Ruby	E121K65	4270	481000	8	8	2.0	3510	
	1.2	0.85	0.05	50	0	100	75	-30	120	Ruby	E121K65	4270	486265	14	14	2.0	3510	
	1.5	1.5	0.09	80	0	-	8	-20	75	PUR	121K0497 <sub>1</sub>	2995	482740	-	1.6	6.0/8.0	8274	
	1.5	1.5	0.09	80	0	10	10	-20	75	PUR	121K0497 <sub>1</sub>	-	495900	2.5	2	6.0/8.0	8274	
	1.5	1.5	0.09	80	0	-	10	-20	75	PUR	121K0497 <sub>1</sub>	-	495910	* -	0.3 to 3	6.0/8.0	8274	
	1.5	1.5	0.09	80	0	-	8	-20	75	PUR	121K0497 <sub>1</sub>	2995	496125	-	1.6	6.0/8.0	8274	
	1.5	1.5	0.09	80	0	60	25	-30	75	PCTFE	E121K04	2995	481865	8	9	2.0	3510	
	1.5	1.5	0.09	80	0	70	30	-30	75	PCTFE	E121K04	4270	481000	8	8	2.0	3510	
	1.5	1.5	0.09	80	0	70	55	-30	75	PCTFE	E121K04	4270	486265	14	14	2.0	3510	
	1.5	1.5	0.09	80	0	20	20	-10	100	FKM	E121K0402	2995	481865	8	9	2.0/3.0	3510	
	1.5	1.5	0.09	80	0	20	20	-10	120	FKM	E121K0402	4270	481000	8	8	2.0/3.0	3510	
	1.5	1.5	0.09	80	0	60	25	-30	100	Ruby	E121K67	2995	481865	8	9	2.0	3510	
	1.5	1.5	0.09	80	0	75	30	-30	130	Ruby	E121K67	4270	481000	8	8	2.0	3510	
	1.5	1.5	0.09	80	0	100	55	-30	120	Ruby	E121K67	4270	486265	14	14	2.0	3510	
	2.5	3.5	0.21	220	0	14	7	-10	100	FKM	121K0706	2995	481865	8	9	2.0	3510	
	2.5	3.5	0.21	220	0	14	9	-10	120	FKM	121K0706	4270	481000	8	8	2.0	3510	
	2.5	3.5	0.21	220	0	14	14	-10	120	FKM	121K0706	4270	486265	14	14	2.0	3510	
	2.5	3.5	0.21	220	0	28	10	-30	75	PCTFE	E121K07	2995	481865	8	9	2.0	3510	
	2.5	3.5	0.21	220	0	34	12	-30	75	PCTFE	E121K07	4270	481000	8	8	2.0	3510	
2.5	3.5	0.21	220	0	50	22	-30	75	PCTFE	E121K07	4270	486265	14	14	2.0	3510		

**Notes:**

1. Valve compatible with water only up to 40°C



## 2 WAY VALVES



For this page	Port size	Orifice (mm)	Kv (l/min)	MOPD (bar)	Fluid Temp (°C)	Amb Temp (°C)
From	1/8"	1.2	0.9	2.5	-30	-20
To	1/4"	3	4.5	100	130	50

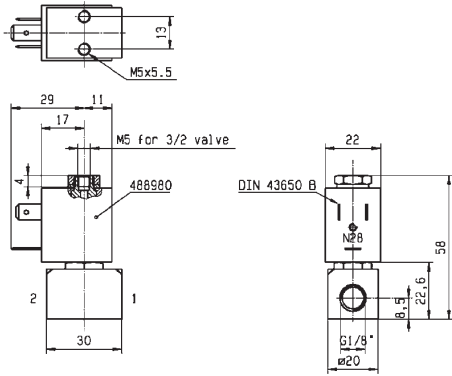

Drawing 3382

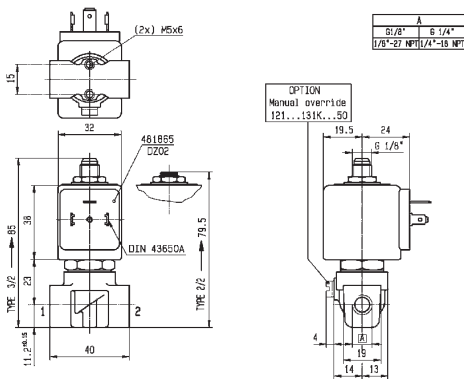

Drawing 3510

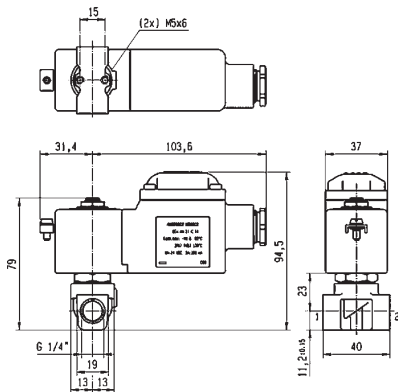

Drawing 8274



## 2 WAY VALVES

# 2/2

### VALVES FOR DRY OR LUBRICATED AIR, NEUTRAL GASES AND LIQUIDS DIRECT OPERATED

#### BRASS PIPE MOUNTING NORMALLY CLOSED

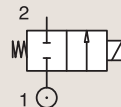

Port size	Orifice Ø	Flow factors			Operating Pressure Differential Max(MOPD)			Fluid Temp.		Seat Seal	Parker LUCIFER® Valves			IS	Power		Coil Group	Dwg. No.
		Kv	KV	Qn	Min	AC	DC	Min	Max		Valve Ref.	Housing Ref.	Coil Ref.		AC W	DC W		
BSP	mm	l/min	m³/h	l/min	bar	bar	bar	°C	°C									
1/4"	2.5	3.5	0.21	220	0	28	10	-30	100	Ruby	E121K63	2995	481865	8	9	2.0	3510	
	2.5	3.5	0.21	220	0	34	12	-30	130	Ruby	E121K63	4270	481000	8	8	2.0	3510	
	2.5	3.5	0.21	220	0	50	22	-30	120	Ruby	E121K63	4270	486265	14	14	2.0	3510	
	3	3.5	0.21	250	0	-	2	-20	75	PUR	121K0397 <sub>1</sub>	2995	482740	-	1.6	6.0/8.0	8074	
	3	3.5	0.21	250	0	4.5	4	-20	75	PUR	121K0397 <sub>1</sub>	-	495900	2.5	2	6.0/8.0	8074	
	3	3.5	0.21	250	0	-	4.5	-20	75	PUR	121K0397 <sub>1</sub>	-	495910	*	-	0.3 to 3	6.0/8.0	8074
	3	3.5	0.21	250	0	-	2	-20	75	PUR	121K0397 <sub>1</sub>	2995	496125	-	1.6	6.0/8.0	8274	
	3	4.5	0.27	320	0	20	7	-30	75	PCTFE	E121K03	2995	481865	8	9	2.0/3.0	3510	
	3	4.5	0.27	320	0	25	8.5	-30	75	PCTFE	E121K03	4270	481000	8	8	2.0/3.0	3510	
	3	4.5	0.27	320	0	36	15	-30	75	PCTFE	E121K03	4270	486265	14	14	2.0/3.0	3510	
	3	4.5	0.27	320	0	10	7	-10	100	FKM	E121K0302	2995	481865	8	9	2.0	3510	
	3	4.5	0.27	320	0	10	8.5	-10	120	FKM	E121K0302	4270	481000	8	8	2.0	3510	
	3	4.5	0.27	320	0	10	7	-10	100	FKM	E121K0302	4270	486265	14	14	2.0	3510	
	3	4.5	0.27	320	0	10	7	-10	100	FKM	E121K0352 <sub>2</sub>	2995	481865	8	9	2.0	3510	
	3	4.5	0.27	320	0	10	8.5	-10	120	FKM	E121K0352 <sub>2</sub>	4270	481000	8	8	2.0	3510	
	3	4.5	0.27	320	0	10	10	-10	120	FKM	E121K0352 <sub>2</sub>	4270	486265	14	14	2.0	3510	
	3	4.5	0.27	320	0	20	7	-30	100	Ruby	E121K64	2995	481865	8	9	2.0	3510	
	3	4.5	0.27	320	0	25	8.5	-30	130	Ruby	E121K64	4270	481000	8	8	2.0	3510	
	3	4.5	0.27	320	0	36	15	-30	120	Ruby	E121K64	4270	486265	14	14	2.0	3510	
	4	7.5	0.45	480	0	10	4	-10	100	FKM	121K02	2995	481865	8	9	2.0	3510	
	4	7.5	0.45	480	0	10	5	-10	120	FKM	121K02	4270	481000	8	8	2.0	3510	
	4	7.5	0.45	480	0	10	10	-10	120	FKM	121K02	4270	486265	14	14	2.0	3510	
	4	7.5	0.45	480	0	10	4	-10	100	FKM	121K0250 <sub>2</sub>	2995	481865	8	9	2.0	3510	
	4	7.5	0.45	480	0	10	5	-10	120	FKM	121K0250 <sub>2</sub>	4270	481000	8	8	2.0	3510	
	4	7.5	0.45	480	0	10	10	-10	120	FKM	121K0250 <sub>2</sub>	4270	486265	14	14	2.0	3510	
	5	11	0.66	750	0	7	2	-10	100	FKM	121K01	2995	481865	8	9	2.0/14.2	3510	
	5	11	0.66	750	0	7	2.8	-10	120	FKM	121K01	4270	481000	8	8	2.0/14.2	3510	
	5	11	0.66	750	0	7	5	-10	120	FKM	121K01	4270	486265	14	14	2.0/14.2	3510	
	5	11	0.66	750	0	7	2	-10	100	FKM	121K0106	2995	481865	8	9	2.0	3510	
	5	11	0.66	750	0	7	2.8	-10	120	FKM	121K0106	4270	481000	8	8	2.0	3510	
	5	11	0.66	750	0	7	5	-10	120	FKM	121K0106	4270	486265	14	14	2.0	3510	
	5	11	0.66	750	0	7	2	-10	100	FKM	121K0150 <sub>2</sub>	2995	481865	8	9	2.0	3510	
	5	11	0.66	750	0	7	2.8	-10	120	FKM	121K0150 <sub>2</sub>	4270	481000	8	8	2.0	3510	
	5	11	0.66	750	0	7	5	-10	120	FKM	121K0150 <sub>2</sub>	4270	486265	14	14	2.0	3510	

#### Notes:

1. Valve compatible with water only up to 40°C
2. With manual override



## 2 WAY VALVES



For this page	Port size	Orifice (mm)	Kv (l/min)	MOPD (bar)	Fluid Temp (°C)	Amb Temp (°C)
From	1/4"	2.5	3.5	2	-30	-20
To	1/4"	5	11	50	130	50

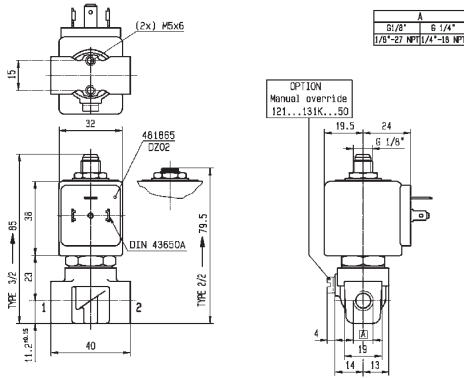

Drawing 3510

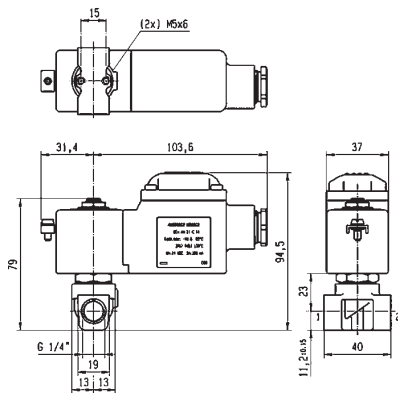

Drawing 8274

## 2 WAY VALVES

# 2/2

### VALVES FOR DRY OR LUBRICATED AIR, NEUTRAL GASES AND LIQUIDS DIRECT OPERATED

BRASS

PIPE MOUNTING

**NORMALLY CLOSED**

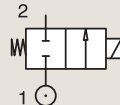

Port size	Orifice Ø	Flow factors			Operating Pressure Differential			Fluid Temp.		Seat Seal	Parker LUCIFER® Valves			Power		Coil Group	Dwg. No.
					Min	AC bar	DC bar	Min	Max		Valve Ref.	Housing Ref.	Coil Ref.	AC W	DC W		
BSP	mm	Kv l/min	KV m³/h	Qn l/min	bar	AC bar	DC bar	°C	°C								
3/8"	4	7.5	0.45	480	0	10	4	-10	100	FKM	121K3206	2995	481865	8	9	2.0	3551
	4	7.5	0.45	480	0	10	5	-10	120	FKM	121K3206	4270	481000	8	8	2.0	3551
	4	7.5	0.45	480	0	10	10	-10	120	FKM	121K3206	4270	486265	14	14	2.0	3551
	5	11	0.66	750	0	7	2	-10	100	FKM	121K3106	2995	481865	8	9	2.0	3551
	5	11	0.66	750	0	7	2.8	-10	120	FKM	121K3106	4270	481000	8	8	2.0	3551
	5	11	0.66	750	0	7	5	-10	120	FKM	121K3106	4270	486265	14	14	2.0	3551
	6	12	0.72	1100	0	5	1.1	-10	100	FKM	121K3306	2995	481865	8	9	2.0/14.2	3551
	6	12	0.72	1100	0	5	1.5	-10	120	FKM	121K3306	4270	481000	8	8	2.0/14.2	3551
1/2"	6	12	0.72	1100	0	5	3	-10	120	FKM	121K3306	4270	486265	14	14	2.0/14.2	3551
	8.5	25	1.5	1600	0	1.1	0.5	-10	100	FKM	E121K46	2995	481865	8	9	2.0	3427
	8.5	25	1.5	1600	0	2.2	0.5	-10	120	FKM	E121K46	4270	481000	8	8	2.0	3427
	8.5	25	1.5	1600	0	4	1.2	-10	120	FKM	E121K46	4270	486265	14	14	2.0	3427
	11	36	2.16	2500	0	0.7	0.3	-10	100	FKM	E121K45	2995	481865	8	9	2.0	3427
	11	36	2.16	2500	0	1.2	0.35	-10	120	FKM	E121K45	4270	481000	8	8	2.0	3427
	11	36	2.16	2500	0	2.5	0.7	-10	120	FKM	E121K45	4270	486265	14	14	2.0	3427



## 2 WAY VALVES



For this page	Port size	Orifice (mm)	Kv (l/min)	MOPD (bar)	Fluid Temp (°C)	Amb Temp (°C)
From	3/8"	4	7.5	0.3	-10	-10
To	1/2"	11	36	10	120	50

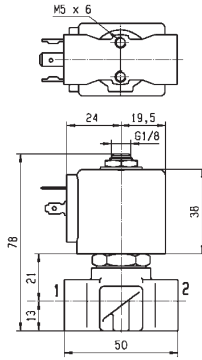

WEIGHT : 215 gr

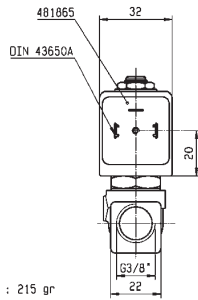

Drawing 3551

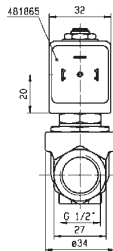
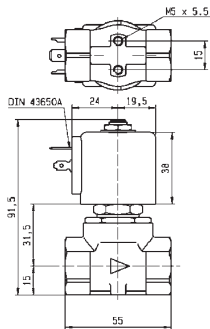

Drawing 3427

## 2 WAY VALVES

# 2/2

### VALVES FOR DRY OR LUBRICATED AIR, NEUTRAL GASES AND LIQUIDS DIRECT OPERATED

BRASS

PIPE MOUNTING

NORMALLY OPEN

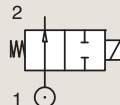

Port size	Orifice Ø	Flow factors			Operating Pressure Differential Max(MOPD)			Fluid Temp.		Seat Seal	Parker Valves			Power		Coil Group	Dwg. No.
		Kv l/min	KV m³/h	Qn m³/h	Min bar	AC bar	DC bar	Min °C	Max °C		Valve Order Number	Valve Type	Coil Type	AC W	DC W		
1/4"	1.5	1.3	0.08	-	0	22	-	-10	140	FKM	363745	PM151GV	ZB09	9	-	20.1/20.2	036
	1.5	1.3	0.08	-	0	-	22	-10	140	FKM	363745	PM151GV	ZB12	-	12	20.1/20.2	036
	2	1.8	0.11	-	0	18	-	-10	140	FKM	362290	PM136.2FV	ZB14	14	-	20.2	020
	2	1.8	0.11	-	0	-	18	-10	140	FKM	362290	PM136.2FV	ZB16	-	16	20.2	020
	2	2.5	0.15	-	0	12	-	-10	140	FKM	363570	PM151HV	ZB09	9	-	20.1/20.2	036
	2	2.5	0.15	-	0	-	12	-10	140	FKM	363570	PM151HV	ZB12	-	12	20.1/20.2	036
	3	4	0.24	-	0	5.5	-	-10	140	FKM	362286	PM136YV	ZB14	14	-	20.2	020
	3	4	0.24	-	0	-	5.5	-10	140	FKM	362286	PM136YV	ZB16	-	16	20.2	020



## 2 WAY VALVES



For this page	Port size	Orifice (mm)	Kv (l/min)	MOPD (bar)	Fluid Temp (°C)	Amb Temp (°C)
From	1/4"	1.5	1.3	5.5	-10	-10
To	1/4"	3	4	22	140	50

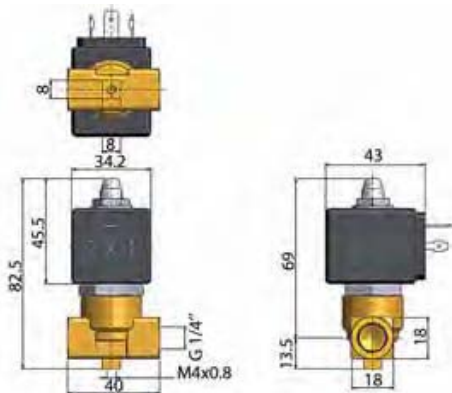

Drawing 036

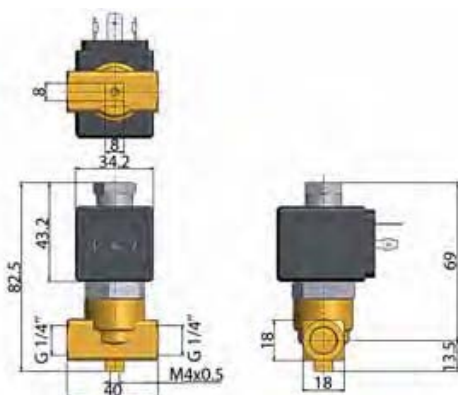

Drawing 020

## 2 WAY VALVES

# 2/2

### VALVES FOR DRY OR LUBRICATED AIR, NEUTRAL GASES AND LIQUIDS DIRECT OPERATED

#### BRASS

#### PIPE MOUNTING

#### NORMALLY OPEN

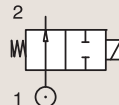

Port size	Orifice Ø	Flow factors			Operating Pressure Differential			Fluid Temp.		Seat Seal	Parker LUCIFER® Valves			Power		Coil Group	Dwg. No.
					Min	Max(MOPD)		Min	Max		Valve Ref.	Housing Ref.	Coil Ref.	AC W	DC W		
					bar	AC bar	DC bar	°C	°C								
1/8"	2.5	3.5	0.21	-	0	30	-	-30	140	Ruby	122K9363	4270	481044	14	-	2.2	3510
	2.5	3.5	0.21	-	0	30	30	-30	140	Ruby	122K9363	4270	486265	14	14	2.2	3510
	1.5	1.5	0.09	9.6	0	30	30	-10	100	PCTFE	122K84	2995	481865	8	9	2.0	3510
	1.5	1.5	0.09	9.6	0	30	30	-10	100	PCTFE	122K84	4270	481000	8	8	2.0	3510
	1.5	1.5	0.09	9.6	0	30	30	-10	120	PCTFE	122K84	4270	486265	14	14	2.0	3510
	1.5	1.5	0.09	80	0	20	20	-10	100	FKM	122K8406	2995	481865	8	9	2.1	3510
1/4"	1.5	1.5	0.09	80	0	20	20	-10	120	FKM	122K8406	4270	481000	8	8	2.1	3510
	1.5	1.5	0.09	80	0	40	40	-30	100	Ruby	122K8408	2995	481865	8	9	2.1	3510
	1.5	1.5	0.09	80	0	40	40	-30	130	Ruby	122K8408	4270	481000	8	8	2.1	3510
	1.5	1.5	0.09	80	0	40	40	-30	130	Ruby	122K8408	4270	486265	14	14	2.0	3510
	2.5	3	0.18	180	0	12	12	-30	75	PCTFE	122K83	2995	481865	8	9	2.1	3510
	2.5	3	0.18	180	0	12	12	-30	75	PCTFE	122K83	4270	481000	8	8	2.1	3510
	2.5	3	0.18	180	0	12	12	-30	75	PCTFE	122K83	4270	486265	14	14	2.0	3510
	2.5	3	0.18	180	0	12	12	-10	100	FKM	122K8306	2995	481865	8	9	2.0	3510
	2.5	3	0.18	180	0	12	12	-10	120	FKM	122K8306	4270	481000	8	8	2.0	3510
	2.5	3	0.18	180	0	12	12	-10	120	FKM	122K8306	4270	486265	14	14	2.0	3510
	2.5	3.5	0.21	-	0	30	-	-30	140	Ruby	122K8363	4270	481044	14	-	2.2	3510
	2.5	3.5	0.21	-	0	30	30	-30	140	Ruby	122K8363	4270	486265	14	14	2.2	3510

#### BRASS

#### PIPE MOUNTING

#### CONTROL BY ELECTRIC IMPULSE

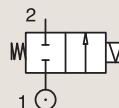

Port size	Orifice Ø	Flow factors			Operating Pressure Differential			Fluid Temp.		Seat Seal	Parker LUCIFER® Valves			Power		Coil Group	Dwg. No.
					Min	Max(MOPD)		Min	Max		Valve Ref.	Housing Ref.	Coil Ref.	AC W	DC W		
					bar	AC bar	DC bar	°C	°C								
1/4"	3	4.5	0.27	320	0	20	-	-30	75	PCTFE	125K03	4269	484990	11	-	4.0	8296
	3	4.5	0.27	320	0	-	7	-30	75	PCTFE	125K03	4269	485400	-	13	4.0	8296
	5	11	0.66	750	0	5	-	-10	100	FKM	125K01	4269	484990	11	-	4.0	8296
	5	11	0.66	750	0	-	1.5	-10	100	FKM	125K01	4269	485400	-	13	4.0	8296



## 2 WAY VALVES



For this page	Port size	Orifice (mm)	Kv (l/min)	MOPD (bar)	Fluid Temp (°C)	Amb Temp (°C)
From	1/8"	1.5	1.5	1.5	-30	-10
To	1/4"	5	11	40	140	50

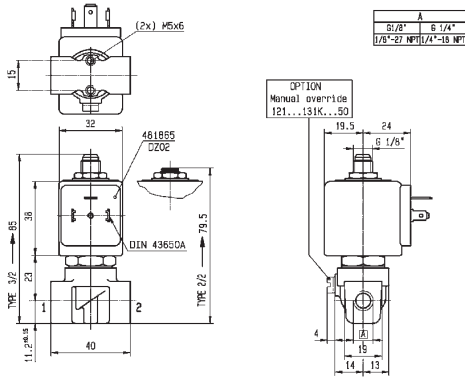

Drawing 3510

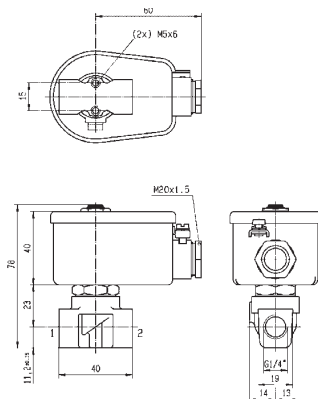

Drawing 8296

## 2 WAY VALVES

# 2/2

### VALVES FOR DRY OR LUBRICATED AIR, NEUTRAL GASES AND LIQUIDS DIRECT OPERATED

#### BRASS

#### SUB-BASE MOUNTING

#### NORMALLY CLOSED

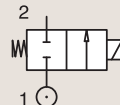

Port size	Orifice Ø mm	Flow factors			Operating Pressure Differential			Fluid Temp.		Seat Seal	Parker LUCIFER® Valves			Power		Coil Group	Dwg. No.
					Min	Max(MOPD)	DC bar	Min	Max		Valve Ref.	Housing Ref.	Coil Ref.	AC W	DC W		
SB	1.5	1.5	0.09	80	0	20	-	-10	100	EPDM	121F4417	2995	483510	9	-	2.0	3509
	1.5	1.5	0.09	80	0	60	25	-30	100	Ruby	121F67	2995	481865	8	9	2.0	3509
	1.5	1.5	0.09	80	0	75	30	-30	130	Ruby	121F67	4270	481000	8	8	2.0	3509
	1.5	1.5	0.09	80	0	100	55	-30	120	Ruby	121F67	4270	486265	14	14	2.0	3509
	1.5	1.5	0.09	80	0	60	25	-30	75	PCTFE	E121F44	2995	481865	8	9	2.0	3509
	1.5	1.5	0.09	80	0	70	30	-30	75	PCTFE	E121F44	4270	481000	8	8	2.0	3509
	1.5	1.5	0.09	80	0	70	55	-30	75	PCTFE	E121F44	4270	486265	14	14	2.0	3509
	1.5	1.5	0.09	80	0	20	20	-10	100	FKM	E121F4406	2995	481865	8	9	2.0	3509
	1.5	1.5	0.09	80	0	20	20	-10	120	FKM	E121F4406	4270	481000	8	8	2.0	3509
	1.5	1.5	0.09	80	0	20	20	-10	120	FKM	E121F4406	4270	486265	14	14	2.0	3509
	2.5	3.5	0.21	220	0	28	10	-30	75	PCTFE	121F47	2995	481865	8	9	2.0	3509
	2.5	3.5	0.21	220	0	34	12	-30	75	PCTFE	121F47	4270	481000	8	8	2.0	3509
	2.5	3.5	0.21	220	0	50	22	-30	75	PCTFE	121F47	4270	486265	14	14	2.0	3509
	2.5	3.5	0.21	220	0	14	7	-10	100	FKM	121F4706	2995	481865	8	9	2.0	3509
	2.5	3.5	0.21	220	0	14	9	-10	120	FKM	121F4706	4270	481000	8	8	2.0	3509
	2.5	3.5	0.21	220	0	14	14	-10	120	FKM	121F4706	4270	486265	14	14	2.0	3509
	2.5	3.5	0.21	220	0	28	10	-30	100	Ruby	121F63	2995	481865	8	9	2.0	3509
	2.5	3.5	0.21	220	0	34	12	-30	130	Ruby	121F63	4270	481000	8	8	2.0	3509
	2.5	3.5	0.21	220	0	50	22	-30	120	Ruby	121F63	4270	486265	14	14	2.0	3509
	3	4.5	0.27	320	0	10	-	-10	100	FKM	121F4317	2995	483510	9	-	2.0	3509
	3	4.5	0.27	320	0	20	7	-30	100	Ruby	121F64	2995	481865	8	9	2.0	3509
	3	4.5	0.27	320	0	25	8.5	-30	130	Ruby	121F64	4270	481000	8	8	2.0	3509
	3	4.5	0.27	320	0	36	15	-30	120	Ruby	121F64	4270	486265	14	14	2.0	3509
	3	4.5	0.27	320	0	20	7	-30	75	PCTFE	E121F43	2995	481865	8	9	2.0	3509
	3	4.5	0.27	320	0	25	8.5	-30	75	PCTFE	E121F43	4270	481000	8	8	2.0	3509
	3	4.5	0.27	320	0	36	15	-30	75	PCTFE	E121F43	4270	486265	14	14	2.0	3509
	3	4.5	0.27	320	0	10	7	-10	100	FKM	E121F4302	2995	481865	8	9	2.0/3.0	3509
	3	4.5	0.27	320	0	10	8.5	-10	120	FKM	E121F4302	4270	481000	8	8	2.0/3.0	3509
	3	4.5	0.27	320	0	10	10	-10	120	FKM	E121F4302	4270	486265	14	14	2.0/3.0	3509



## 2 WAY VALVES



For this page	Port size	Orifice (mm)	Kv (l/min)	MOPD (bar)	Fluid Temp (°C)	Amb Temp (°C)
From	5 mm	1.5	1.5	7	-30	-10
To	5 mm	3	4.5	100	130	50

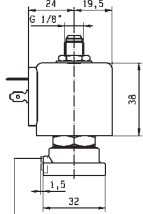
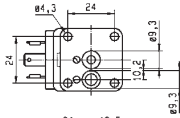

OPTION  
Manual override  
121...131F...50

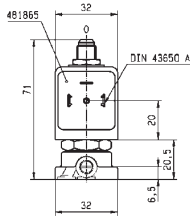

Drawing 3509

## 2 WAY VALVES

# 2/2

VALVES FOR DRY OR LUBRICATED AIR, NEUTRAL GASES AND LIQUIDS  
DIRECT OPERATED

BRASS

SUB-BASE MOUNTING

**NORMALLY OPEN**

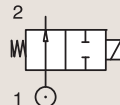

Port size	Orifice Ø mm	Flow factors			Operating Pressure Differential			Fluid Temp.		Seat Seal	Parker LUCIFER® Valves			Power		Coil Group	Dwg. No.
		Kv l/min	KV m³/h	Qn l/min	Min bar	Max(MOPD)		Min °C	Max °C		Valve Ref.	Housing Ref.	Coil Ref.	AC W	DC W		
						AC bar	DC bar										
SB	1.5	1.5	0.09	80	0	20	20	-10	100	FKM	122F44	2995	481865	8	9	2.1	3509
	1.5	1.5	0.09	80	0	20	20	-10	120	FKM	122F44	4270	481000	8	8	2.1	3509

## 2 WAY VALVES



For this page	Port size	Orifice (mm)	Kv (l/min)	MOPD (bar)	Fluid Temp (°C)	Amb Temp (°C)
From	5 mm	1.5	1.5	20	-10	-10
To	5 mm	1.5	1.5	20	120	50

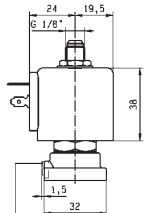
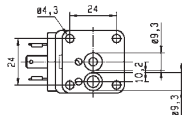

OPTION  
Manual override  
121...131F...50

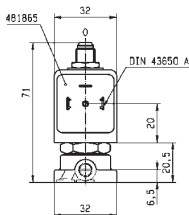

Drawing 3509

## 2 WAY VALVES

# 2/2

### VALVES FOR DRY OR LUBRICATED AIR, NEUTRAL GASES AND LIQUIDS MAGNALIFT



Commercial Equipment



Industrial Equipment

BRASS  
PIPE MOUNTING

**NORMALLY CLOSED**

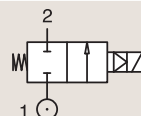

Port size	Orifice Ø	Flow factors			Operating Pressure Differential			Fluid Temp.		Seat Seal	Parker Valves			Power		Coil Group	Dwg. No.
		Kv	KV	Qn	Min	Max(MOPD)	Min	Max	Valve Order Number		Valve Type	Coil Type	AC W	DC W			
BSP	mm	l/min	m <sup>3</sup> /h	m <sup>3</sup> /h	bar	AC bar	DC bar	°C	°C								
3/8"	13	40	2.4	-	0	5	-	-10	140	FKM	361810	PM123IV	ZB09	9	-	20.1	004
1/2"	13	40	2.4	-	0	5	-	-10	140	FKM	361850	PM123AV	ZB09	9	-	20.1	003
3/4"	20	100	6	-	0	3	-	-10	140	FKM	361910	PM123CV	JB14	14	-	21.0	005
1"	25	117	7	-	0	3	-	-10	140	FKM	361950	PM123DV	JB14	14	-	21.0	006

## 2 WAY VALVES



For this page	Port size	Orifice (mm)	Kv (l/min)	MOPD (bar)	Fluid Temp (°C)	Amb Temp (°C)
From	3/8"	13	40	3	-10	-10
To	1"	25	117	5	140	50

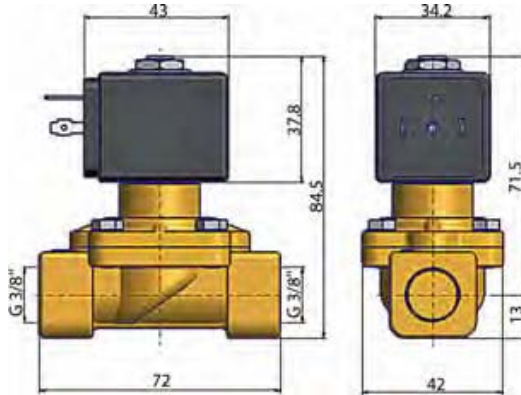

Drawing 004

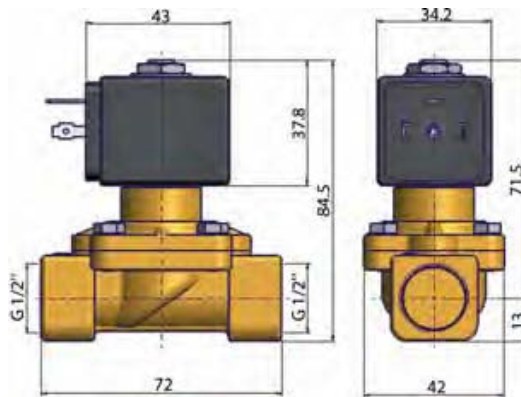

Drawing 003

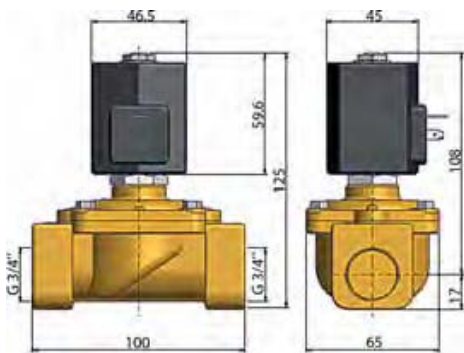

Drawing 005

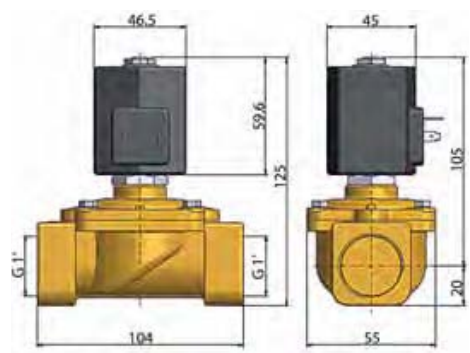

Drawing 006

## 2 WAY VALVES

# 2/2

# VALVES FOR DRY OR LUBRICATED AIR, NEUTRAL GASES AND LIQUIDS MAGNALIFT

### BRASS

### PIPE MOUNTING

### NORMALLY CLOSED

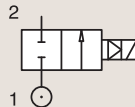

Port size	Orifice Ø	Flow factors			Operating Pressure Differential			Fluid Temp.		Seat Seal	Parker LUCIFER® Valves			Power		Coil Group	Dwg. No.
		Kv l/min	KV m³/h	Qn l/min	Min bar	Max(MOPD) AC bar	DC bar	Min °C	Max °C		Valve Ref.	Housing Ref.	Coil Ref.	AC W	DC W		
3/8"	15	65	3.9	4500	0	16	-	-10	100	NBR	221G13	2995	481865	8	-	2.0	3732
	15	65	3.9	4500	0	16	-	-10	100	NBR	221G13	4270	481000	8	-	2.0	3732
	15	65	3.9	4500	0	16	7	-10	100	NBR	221G13	4270	486265	14	14	2.0	3732
	15	65	3.9	4500	0	16	-	0	100	FKM	221G23 <sub>1</sub>	2995	481865	8	-	2.0	3732
	15	65	3.9	4500	0	16	-	0	120	FKM	221G23 <sub>1</sub>	4270	481000	8	-	2.0	3732
	15	65	3.9	4500	0	20	7	0	140	FKM	221G23 <sub>1</sub>	4270	486265	14	14	2.0	3732
	15	65	3.9	4500	0	-	10	-10	100	FKM	221G2330 <sub>12</sub>	2995	481865	-	9	2.1	3732
	15	65	3.9	4500	0	10	10	-10	100	FKM	221G2330 <sub>12</sub>	-	492070	9	8	2.1	3732
1/2"	15	65	3.9	4500	0	10	10	-10	100	FKM	221G2330 <sub>12</sub>	-	492190	11	9	2.1	3732
	15	65	3.9	4500	0	16	-	-10	100	NBR	221G15	2995	481865	8	-	2.0	3732
	15	65	3.9	4500	0	16	-	-10	100	NBR	221G15	4270	481000	8	-	2.0	3732
	15	65	3.9	4500	0	16	7	-10	100	NBR	221G15	4270	486265	14	14	2.0	3732
	15	65	3.9	4500	0	-	10	-10	100	NBR	221G1530 <sub>23</sub>	2995	481865	-	9	2.1	3732
	15	65	3.9	4500	0	10	10	-10	120	NBR	221G1530 <sub>23</sub>	-	492070	9	8	2.1	3732
	15	65	3.9	4500	0	10	10	-10	120	NBR	221G1530 <sub>23</sub>	-	492190	11	9	2.1	3732
	15	65	3.9	4500	0	16	-	0	100	FKM	221G25 <sub>1</sub>	2995	481865	8	-	2.0	3732
	15	65	3.9	4500	0	16	-	0	120	FKM	221G25 <sub>1</sub>	4270	481000	8	-	2.0	3732
	15	65	3.9	4500	0	20	7	0	140	FKM	221G25 <sub>1</sub>	4270	486265	14	14	2.0	3732
	15	65	3.9	4500	0	-	10	-10	100	FKM	221G2530 <sub>12</sub>	2995	481865	-	9	2.1	3732
	15	65	3.9	4500	0	10	10	-10	100	FKM	221G2530 <sub>12</sub>	-	492070	9	8	2.1	3732
15	65	3.9	4500	0	10	10	-10	100	FKM	221G2530 <sub>12</sub>	-	492190	11	9	2.1	3732	

#### Notes:

1. Valve only compatible with hydraulic oil and air/neutral gases
2. Valves with model number ending in 30 or 31 are only compatible with explosion proof electrical parts shown, or with group 2.1 coils only in DC voltage.
3. Pilot seat in FKM



## 2 WAY VALVES



For this page	Port size	Orifice (mm)	Kv (l/min)	MOPD (bar)	Fluid Temp (°C)	Amb Temp (°C)
From	3/8"	15	65	7	-10	-10
To	1/2"	15	65	20	140	50

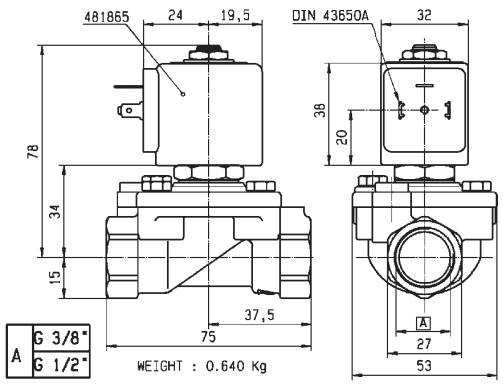

Drawing 3732

## 2 WAY VALVES

# 2/2

# VALVES FOR DRY OR LUBRICATED AIR, NEUTRAL GASES AND LIQUIDS MAGNALIFT

### BRASS

### PIPE MOUNTING

### NORMALLY CLOSED

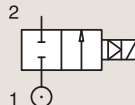

Port size	Orifice Ø	Flow factors			Operating Pressure Differential			Fluid Temp.		Seat Seal	Parker LUCIFER® Valves			Power		Coil Group	Dwg. No.
											Valve Ref.	Housing Ref.	Coil Ref.	AC W	DC W		
3/4"	15	80	4.8	6000	0	16	-	-10	100	NBR	221G16 <sub>4</sub>	2995	481865	8	-	2.0	3444
						16	-	-10	100	NBR	221G16 <sub>4</sub>	4270	481000	8	-	2.0	3444
	15	80	4.8	6000	0	7	7	-10	100	NBR	221G16 <sub>4</sub>	4270	486265	14	14	2.0	3444
						16	-	-10	100	NBR	221G1610 <sub>3</sub>	2995	481865	8	-	2.0	3444
	15	80	4.8	6000	0	16	-	-10	100	NBR	221G1610 <sub>3</sub>	4270	481000	8	-	2.0	3444
						16	7	-10	100	NBR	221G1610 <sub>3</sub>	4270	486265	14	14	2.0	3444
	15	80	4.8	6000	0	10	10	-10	100	NBR	221G1630 <sub>24</sub>	2995	481865	8	9	2.1	3444
						10	10	-25	40	NBR	221G1630 <sub>24</sub>	-	492070	9	8	2.1	3444
	15	80	4.8	6000	0	10	10	-25	40	NBR	221G1630 <sub>24</sub>	-	492190	11	9	2.1	3444
						10	10	-10	100	NBR	221G1631 <sub>234</sub>	2995	481865	8	9	2.1	3444
	15	80	4.8	6000	0	10	10	-25	40	NBR	221G1631 <sub>234</sub>	-	492070	9	8	2.1	3444
						10	10	-25	40	NBR	221G1631 <sub>234</sub>	-	492190	11	9	2.1	3444
	15	80	4.8	6000	0	16	-	0	100	FKM	221G26 <sub>1</sub>	2995	481865	8	-	2.0	3444
						16	-	0	120	FKM	221G26 <sub>1</sub>	4270	481000	8	-	2.0	3444
	15	80	4.8	6000	0	20	7	0	140	FKM	221G26 <sub>1</sub>	4270	486265	14	14	2.0	3444
						-	10	-10	100	FKM	221G2630 <sub>12</sub>	2995	481865	-	9	2.1	3444
	15	80	4.8	6000	0	10	10	-25	40	FKM	221G2630 <sub>12</sub>	-	492070	9	8	2.1	3444
						10	10	-25	40	FKM	221G2630 <sub>12</sub>	-	492190	11	9	2.1	3444

#### Notes:

1. Valve only compatible with hydraulic oil and air/neutral gases
2. Valves with model number ending in 30 or 31 are only compatible with explosion proof electrical parts shown, or with group 2.1 coils only in DC voltage.
3. With 4 position selector for controlled closure rate
4. Pilot seat in FKM



## 2 WAY VALVES



For this page	Port size	Orifice (mm)	Kv (l/min)	MOPD (bar)	Fluid Temp (°C)	Amb Temp (°C)
From	3/4"	15	80	7	-25	-10
To	3/4"	15	80	20	140	50

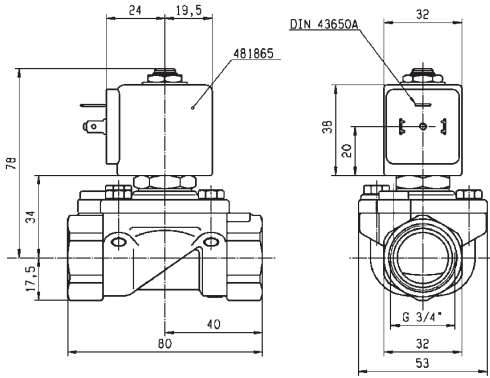

Drawing 3444

## 2 WAY VALVES

# 2/2

# VALVES FOR DRY OR LUBRICATED AIR, NEUTRAL GASES AND LIQUIDS MAGNALIFT

### BRASS PIPE MOUNTING

### NORMALLY CLOSED

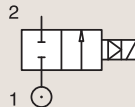

Port size	Orifice Ø	Flow factors			Operating Pressure Differential			Fluid Temp.		Seat Seal	Parker LUCIFER® Valves			Power		Coil Group	Dwg. No.
					Min	AC	DC	Min	Max		Valve Ref.	Housing Ref.	Coil Ref.	AC W	DC W		
					bar	bar	bar	°C	°C								
1"	15	80	4.8	6000	0	16	-	-10	100	NBR	221G17	2995	481865	8	-	2.0	3445
	15	80	4.8	6000	0	16	1	-10	100	NBR	221G17	4270	481000	8	8	2.0	3445
	15	80	4.8	6000	0	16	7	-10	100	NBR	221G17	4270	486265	14	14	2.0	3445
	15	80	4.8	6000	0	16	-	-10	100	NBR	221G1710 <sub>3</sub>	2995	481865	8	-	2.0	3445
	15	80	4.8	6000	0	16	-	-10	100	NBR	221G1710 <sub>3</sub>	4270	481000	8	-	2.0	3445
	15	80	4.8	6000	0	16	7	-10	100	NBR	221G1710 <sub>3</sub>	4270	486265	14	14	2.0	3445
	15	80	4.8	6000	0	10	10	-10	100	NBR	221G1730 <sub>124</sub>	2995	481865	8	9	2.1	3445
	15	80	4.8	6000	0	10	10	-10	120	NBR	221G1730 <sub>124</sub>	-	492070	9	8	2.1	3445
	15	80	4.8	6000	0	10	10	-10	120	NBR	221G1730 <sub>124</sub>	-	492190	11	9	2.1	3445
	15	80	4.8	6000	0	16	-	0	100	FKM	221G27 <sub>1</sub>	2995	481865	8	-	2.0	3445
	15	80	4.8	6000	0	16	-	0	120	FKM	221G27 <sub>1</sub>	4270	481000	8	-	2.0	3445
	15	80	4.8	6000	0	20	7	0	120	FKM	221G27 <sub>1</sub>	4270	486265	14	14	2.0	3445
	15	80	4.8	6000	0	-	10	0	100	FKM	221G2730 <sub>12</sub>	2995	481865	-	9	2.1	3445
	15	80	4.8	6000	0	10	10	-10	65	FKM	221G2730 <sub>12</sub>	-	492070	9	8	2.1	3445
	15	80	4.8	6000	0	10	10	-10	75	FKM	221G2730 <sub>12</sub>	-	492190	11	9	2.1	3445
	25	170	10.2	14000	0	16	-	-10	100	NBR	221G21	2995	481865	8	-	2.0	3448
	25	170	10.2	14000	0	16	-	-10	100	NBR	221G21	4270	481000	8	-	2.0	3448
	25	170	10.2	14000	0	16	6	-10	100	NBR	221G21	4270	486265	14	14	2.0	3448
	25	160	9.6	14000	0	16	-	0	100	FKM	221G2106 <sub>1</sub>	2995	481865	8	-	2.0	3448
	25	160	9.6	14000	0	16	-	0	120	FKM	221G2106 <sub>1</sub>	4270	481000	8	-	2.0	3448
	25	160	9.6	14000	0	16	6	0	120	FKM	221G2106 <sub>1</sub>	4270	486265	14	14	2.0	3448
	25	160	9.6	14000	0	16	-	-10	100	NBR	221G2110 <sub>3</sub>	2995	481865	8	-	2.0	3448
	25	160	9.6	14000	0	16	-	-10	100	NBR	221G2110 <sub>3</sub>	4270	481000	8	-	2.0	3448
	25	160	9.6	14000	0	16	6	-10	100	NBR	221G2110 <sub>3</sub>	4270	486265	14	14	2.0	3448
	25	170	10.2	14000	0	-	10	-10	100	NBR	221G2130 <sub>124</sub>	2995	481865	-	9	2.1	3448
	25	170	10.2	14000	0	10	10	-25	40	NBR	221G2130 <sub>124</sub>	-	492070	9	8	2.1	3448
	25	170	10.2	14000	0	10	10	-25	40	NBR	221G2130 <sub>124</sub>	-	492190	11	9	2.1	3448
	25	170	10.2	14000	0	-	10	0	100	FKM	221G2136 <sub>1</sub>	2995	481865	-	9	2.0	3448
	25	170	10.2	14000	0	-	10	0	100	FKM	221G2136 <sub>1</sub>	4270	481000	-	8	2.0	3448

#### Notes:

1. Valve only compatible with hydraulic oil and air/neutral gases
2. Valves with model number ending in 30 or 31 are only compatible with explosion proof electrical parts shown, or with group 2.1 coils only in DC voltage.
3. With 4 position selector for controlled closure rate
4. Pilot seat in FKM



## 2 WAY VALVES



For this page	Port size	Orifice (mm)	Kv (l/min)	MOPD (bar)	Fluid Temp (°C)	Amb Temp (°C)
From	1"	15	80	1	-25	-10
To	1"	25	170	20	120	50

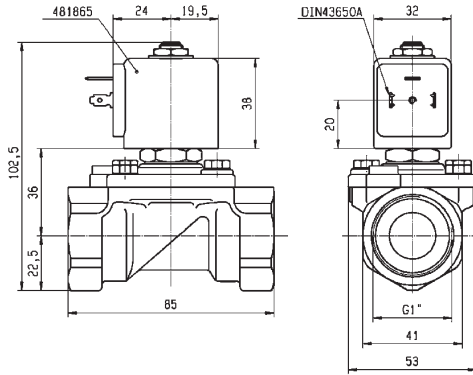

Drawing 3445

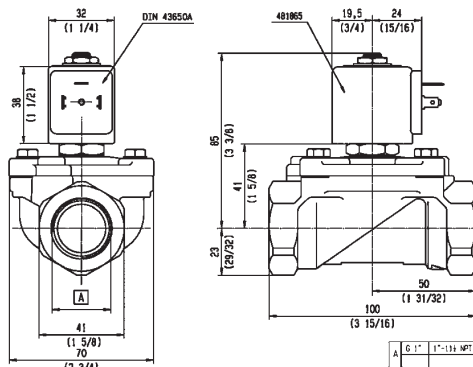

Drawing 3448

## 2 WAY VALVES

# 2/2

## VALVES FOR DRY OR LUBRICATED AIR, NEUTRAL GASES AND LIQUIDS PILOT OPERATED



Commercial Equipment



Industrial Equipment

BRASS  
PIPE MOUNTING

**NORMALLY CLOSED**

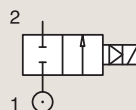

Port size	Orifice Ø	Flow factors			Operating Pressure Differential			Fluid Temp.		Seat Seal	Parker Valves			Power		Coil Group	Dwg. No.
		Kv l/min	KV m <sup>3</sup> /h	Qn m <sup>3</sup> /h	Min bar	Max(MOPD) AC bar	DC bar	Min °C	Max °C		Valve Order Number	Valve Type	Coil Type	AC W	DC W		
3/8"	13	33	2	-	0.5	16	-	-10	90	NBR	366501 <sub>1</sub>	PM168.1IN	ZB09	9	-	20.1/20.2	048
	13	33	2	-	0.5	-	16	-10	90	NBR	366501 <sub>1</sub>	PM168.1IN	ZB12	-	12	20.1/20.2	048
	13	50	3	-	0.35	15	-	-10	90	NBR	366770	PM173IN	WB4.5	4.5	-	1.3	054
	13	50	3	-	0.35	-	12	-10	90	NBR	366770	PM173IN	WB5.0	-	5	1.3	054
1/2"	13	42	2.5	-	0.5	16	-	-10	90	NBR	366511 <sub>1</sub>	PM168.1AN	ZB09	9	-	20.1/20.2	046
	13	42	2.5	-	0.5	-	16	-10	90	NBR	366511 <sub>1</sub>	PM168.1AN	ZB12	-	12	20.1/20.2	046
	13	58	3.5	-	0.35	15	-	-10	90	NBR	366775	PM173AN	WB4.5	4.5	-	1.3	053
3/4"	13	58	3.5	-	0.35	-	12	-10	90	NBR	366775	PM173AN	WB5.0	-	5	1.3	053
	20	117	7	-	0.5	16	-	-10	90	NBR	366521 <sub>1</sub>	PM168.1CN	ZB09	9	-	20.1/20.2	046
1"	20	117	7	-	0.5	-	16	-10	90	NBR	366521 <sub>1</sub>	PM168.1CN	ZB12	-	12	20.1/20.2	046
	25	133	8	-	0.5	16	-	-10	90	NBR	366531 <sub>1</sub>	PM168.1DN	ZB09	9	-	20.1/20.2	047
	25	133	8	-	0.5	-	16	-10	90	NBR	366531 <sub>1</sub>	PM168.1DN	ZB12	-	12	20.1/20.2	047

**Notes:**

1. Valve only compatible with air and neutral gases



## 2 WAY VALVES



For this page	Port size	Orifice (mm)	Kv (l/min)	MOPD (bar)	Fluid Temp (°C)	Amb Temp (°C)
From	3/8"	13	33	12	-10	-10
To	1"	25	133	16	90	50

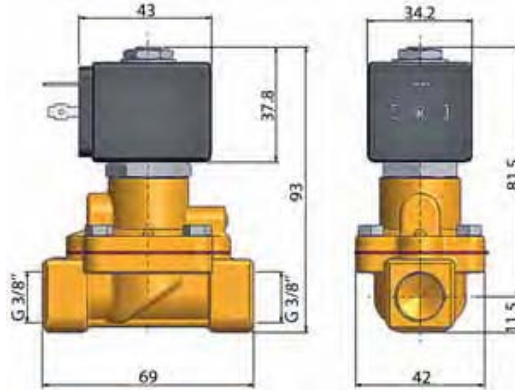

Drawing 048

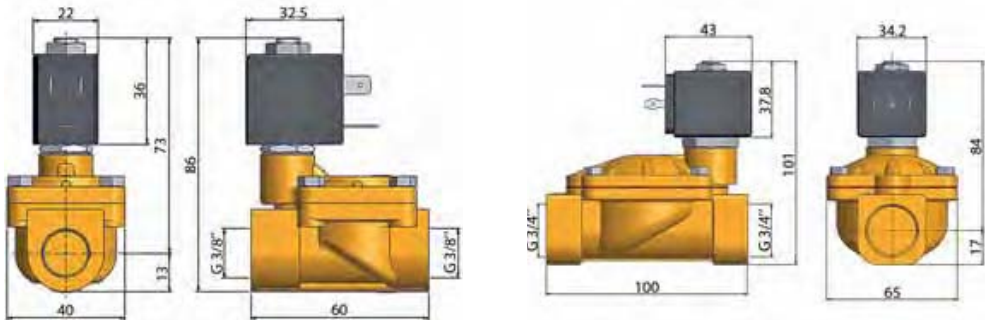

Drawing 054

Drawing 046

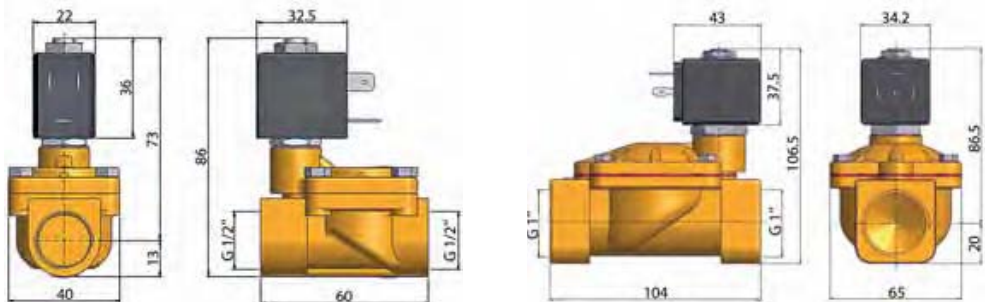

Drawing 053

Drawing 047



## 2 WAY VALVES

# 2/2

### VALVES FOR DRY OR LUBRICATED AIR, NEUTRAL GASES AND LIQUIDS PILOT OPERATED

BRASS  
PIPE MOUNTING

**NORMALLY CLOSED**

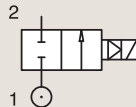

Port size	Orifice Ø	Flow factors			Operating Pressure Differential			Fluid Temp.		Seat Seal	Parker LUCIFER® Valves			Power		Coil Group	Dwg. No.
		Kv l/min	KV m³/h	Qn l/min	Min bar	AC bar	DC bar	Min °C	Max °C		Valve Ref.	Housing Ref.	Coil Ref.	AC W	DC W		
1/4"	8	36	2.16	1600	0.3	40	25	-10	100	NBR	E321H11 <sup>124</sup>	2995	481865	8	9	2.0	3523
	8	36	2.16	1600	0.3	40	30	-10	100	NBR	E321H11 <sup>124</sup>	4270	481000	8	8	2.0	3523
	8	36	2.16	1600	0.3	40	40	-10	100	NBR	E321H11 <sup>124</sup>	4270	486265	14	14	2.0	3523
	11	28	1.68	1800	0.2	10	3	-10	100	NBR	E321K10	2995	481865	8	9	2.0	3429
	11	28	1.68	1800	0.2	10	4	-10	100	NBR	E321K10	4270	481000	8	8	2.0	3429
	12	30	1.8	2150	0.3	10	10	-10	100	NBR	321K31	8993	481180	4	5	1.1	7093
	12	30	1.8	2150	0.3	10	7	-10	75	NBR	321K31	8993	488980	2	2.5	1.1	7093
	12	30	1.8	2150	0.3	10	10	-10	100	FKM	321K3106	8993	481180	4	5	1.1	7093
	12	30	1.8	2150	0.3	10	7	-10	75	FKM	321K3106	8993	488980	2	2.5	1.1	7093
	12	32	1.92	2150	0.3	12	12	-10	100	FKM	321K4156 <sup>3</sup>	2995	481865	8	9	2.1/3.0	7094
	12	32	1.92	2150	0.3	12	12	-10	120	FKM	321K4156 <sup>3</sup>	4270	481000	8	8	2.1/3.0	7094

**Notes:**

1. Minimum pressure differential = 0.3 bar for opening and 0 bar for closing
2. Pilot seat disc in synthetic Ruby
3. Valve with manual override
4. With 4 position selector for controlled closure rate

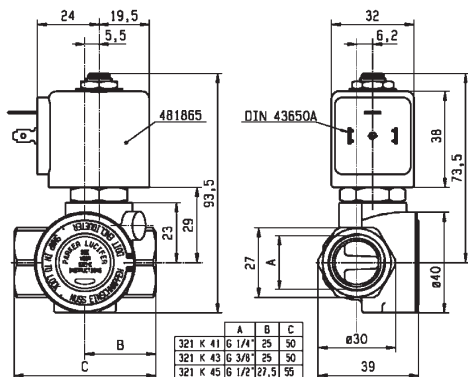

Drawing 7094



## 2 WAY VALVES



For this page	Port size	Orifice (mm)	Kv (l/min)	MOPD (bar)	Fluid Temp (°C)	Amb Temp (°C)
From	1/4"	8	28	3	-10	-10
To	1/4"	12	36	40	120	50

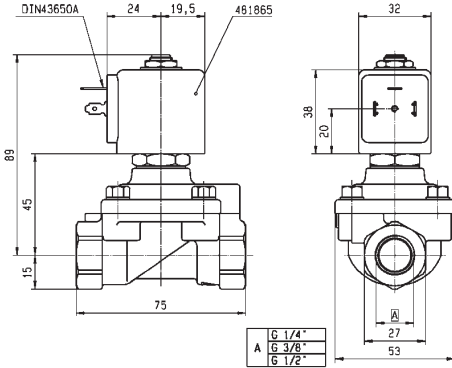

Drawing 3523

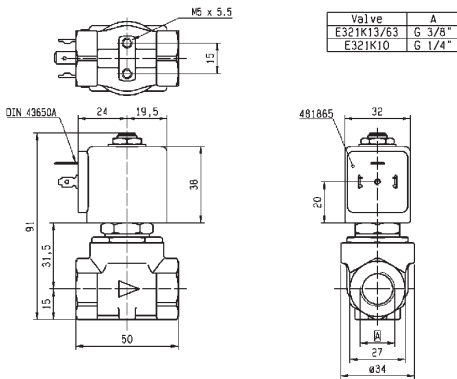

Drawing 3429

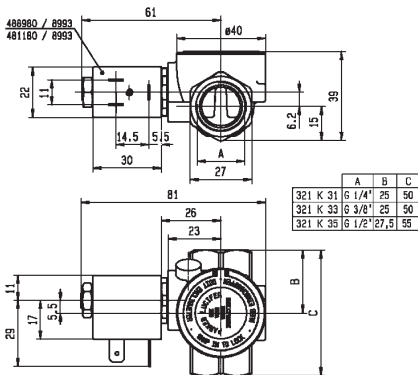

Drawing 7093



## 2 WAY VALVES

# 2/2

### VALVES FOR DRY OR LUBRICATED AIR, NEUTRAL GASES AND LIQUIDS PILOT OPERATED

#### BRASS

#### PIPE MOUNTING

#### NORMALLY CLOSED

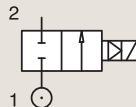

Port size	Orifice Ø	Flow factors			Operating Pressure Differential			Fluid Temp.		Seat Seal	Parker LUCIFER® Valves			Power		Coil Group	Dwg. No.
					Min	Max(MOPD)		Min	Max		Valve Ref.	Housing Ref.	Coil Ref.	AC W	DC W		
						AC bar	DC bar										
3/8"	11	50	3	2800	0.3	40	25	-10	100	NBR	E321H13 <sup>124</sup>	2995	481865	8	9	2.0	3521
	11	50	3	2800	0.3	40	30	-10	100	NBR	E321H13 <sup>124</sup>	4270	481000	8	8	2.0	3521
	11	50	3	2800	0.3	40	40	-10	100	NBR	E321H13 <sup>124</sup>	4270	486265	14	14	2.0	3521
	11	36	2.16	2500	0.2	10	4	-10	100	NBR	E321K13	4270	481000	8	8	2.0	3429
	11	36	2.16	2500	0.2	10	10	-10	100	NBR	E321K13	4270	486265	14	14	2.0	3429
	11	36	2.16	2500	0.2	10	-	-10	100	NBR	E321K1314	2995	483466	8 <sup>10</sup> 11	-	2.0	3429
	11	36	2.16	2500	0.2	10	10	-10	100	NBR	E321K1314	4270	486265	14	14	2.0	3429
	12	45	2.7	3050	0.3	10	10	-10	100	NBR	321K33	8993	481180	4	5	1.1	7093
	12	45	2.7	3050	0.3	10	7	-10	75	NBR	321K33	8993	488980	2	2.5	1.1	7093
	12	45	2.7	3050	0.3	10	10	-10	100	FKM	321K3306 <sup>1</sup>	8993	481180	4	5	1.1	7093
	12	45	2.7	3050	0.3	10	7	-10	75	FKM	321K3306 <sup>1</sup>	8993	488980	2	2.5	1.1	7093
	12	45	2.7	3050	0.3	12	12	-10	100	FKM	321K4356 <sup>3</sup>	2995	481865	8	9	2.1/3.0	7094
12	45	2.7	3050	0.3	12	12	-10	120	FKM	321K4356 <sup>3</sup>	4270	481000	8	8	2.1/3.0	7094	

#### Notes:

1. Minimum pressure differential = 0.3 bar for opening and 0 bar for closing
2. Pilot seat disc in synthetic Ruby
3. Valve with manual override
4. With 4 position selector for controlled closure rate

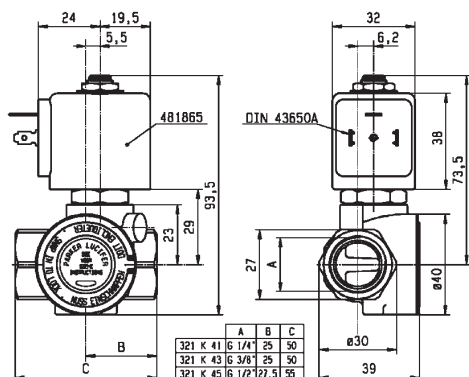

Drawing 7094



## 2 WAY VALVES



For this page	Port size	Orifice (mm)	Kv (l/min)	MOPD (bar)	Fluid Temp (°C)	Amb Temp (°C)
From	3/8"	11	36	4	-10	-10
To	3/8"	12	50	40	120	50

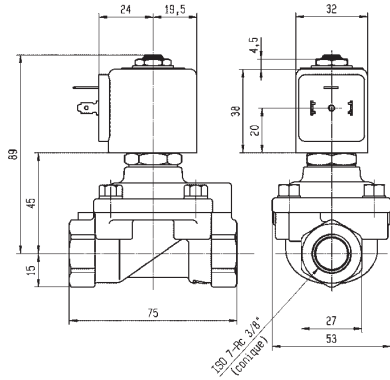

Drawing 3521

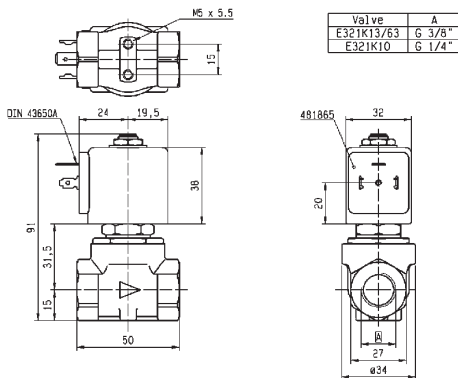

Drawing 3429

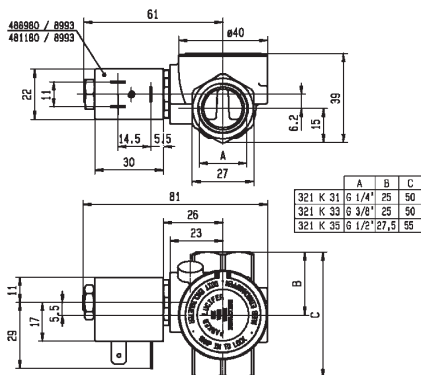

Drawing 7093

## 2 WAY VALVES

# 2/2

## VALVES FOR DRY OR LUBRICATED AIR, NEUTRAL GASES AND LIQUIDS PILOT OPERATED

### BRASS

### PIPE MOUNTING

### NORMALLY CLOSED

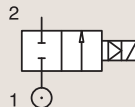

Port size	Orifice Ø	Flow factors			Operating Pressure Differential Max(MOPD)			Fluid Temp.		Seat Seal	Parker LUCIFER® Valves			IS	Power		Coil Group	Dwg. No.
		BSP	mm	Kv l/min	KV m³/h	Qn l/min	Min bar	AC bar	DC bar		Min °C	Max °C	Valve Ref.		Housing Ref.	Coil Ref.		
1/2"	11	36	2.16	2500	0.2	10	3	-10	100	NBR	E321K15	2995	481865	8	9	2.0	3427	
	11	36	2.16	2500	0.2	10	10	-10	120	NBR	E321K15	4270	486265	14	14	2.0	3427	
	11	36	2.16	2500	0.2	10	3	-10	100	NBR	E321K1514	2995	481865	8	9	2.0	3427	
	11	36	2.16	2500	0.2	10	4	-10	120	NBR	E321K1514	-	483371	8	8	2.0	3427	
	11	36	2.16	2500	0.2	10	3	-10	100	NBR	E321K25	2995	481865	8	9	2.0	3427	
	11	36	2.16	2500	0.2	4	4	-10	120	NBR	E321K25	-	492070	9	8	2.0	3427	
	12	50	3	3400	0.3	10	10	-10	100	NBR	321K35	8993	481180	4	5	1.1	7093	
	12	50	3	3400	0.3	10	7	-10	75	NBR	321K35	8993	488980	2	2.5	1.1	7093	
	12	50	3	3400	0.3	10	10	-10	100	FKM	321K3506	8993	481180	4	5	1.1	7093	
	12	50	3	3400	0.3	10	7	-10	75	FKM	321K3506	8993	488980	2	2.5	1.1	7093	
	15	60	3.6	3150	0.3	-	10	-10	100	NBR	321H1590	2995	483580.01	*	-	0.5 to 3	7.0/8.0	3978
	15	60	3.6	3150	0.3	-	10	-10	100	NBR	321H1590	-	488660.01	*	-	0.3 to 3	7.0/8.0	3978
	15	60	3.6	3150	0.3	-	10	-10	100	NBR	321H1590	-	495910	*	-	0.3 to 3	7.0/8.0	3978
	15	60	3.6	3150	1.5	40	40	-10	50	PUR	321H35 <sub>23</sub>	2995	481865	8	9	2.1	3522	
	15	60	3.6	3150	1.5	40	40	-10	50	PUR	321H35 <sub>23</sub>	4270	481000	8	8	2.1	3522	
	15	60	3.6	3150	0.3	40	25	-10	100	NBR	E321H15 <sub>124</sub>	2995	481865	8	9	2.0	3522	
	15	60	3.6	3150	0.3	40	30	-10	100	NBR	E321H15 <sub>124</sub>	4270	481000	8	8	2.0	3522	
	15	60	3.6	3150	0.3	40	40	-10	100	NBR	E321H15 <sub>124</sub>	4270	486265	14	14	2.0	3522	

#### Notes:

1. Minimum pressure differential = 0.3 bar for opening and 0 bar for closing
2. Pilot seat disc in synthetic Ruby
3. Valve with manual override
4. With 4 position selector for controlled closure rate

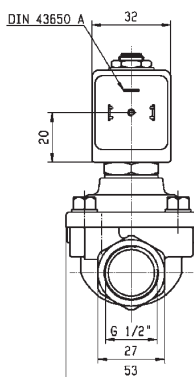
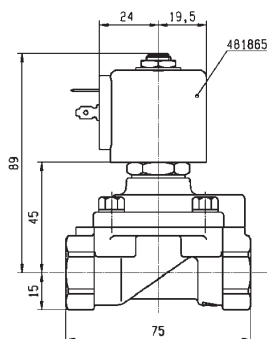

Drawing 3522



## 2 WAY VALVES



For this page	Port size	Orifice (mm)	Kv (l/min)	MOPD (bar)	Fluid Temp (°C)	Amb Temp (°C)
From	1/2"	11	36	3	-10	-10
To	1/2"	15	60	40	120	50

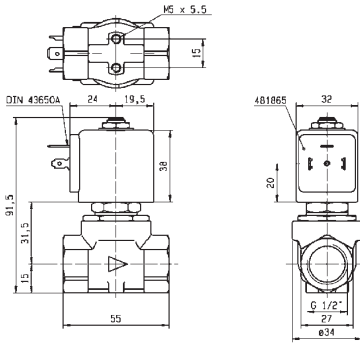

Drawing 3427

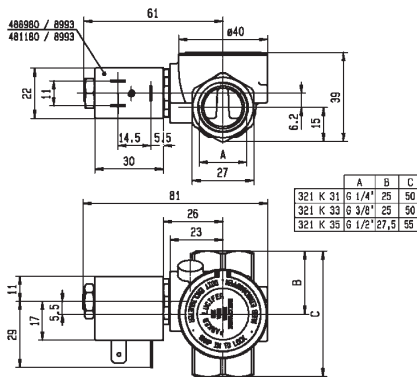

Drawing 7093

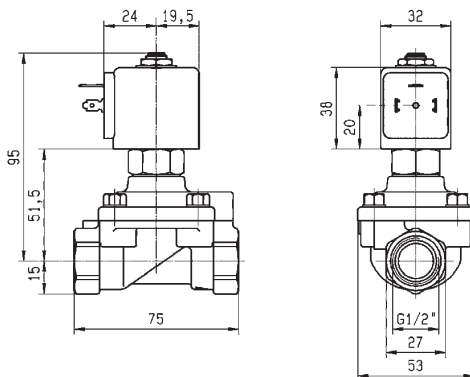

Drawing 3978

## 2 WAY VALVES

# 2/2

### VALVES FOR DRY OR LUBRICATED AIR, NEUTRAL GASES AND LIQUIDS PILOT OPERATED

#### BRASS

#### PIPE MOUNTING

#### NORMALLY CLOSED

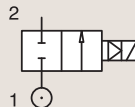

Port size	Orifice Ø	Flow factors			Operating Pressure Differential			Fluid Temp.		Seat Seal	Parker LUCIFER® Valves			Power		Coil Group	Dwg. No.
					Min	Max(MOPD)	DC bar	Min	Max		Valve Ref.	Housing Ref.	Coil Ref.	AC W	DC W		
BSP	mm	Kv l/min	KV m³/h	Qn l/min	bar	AC bar	DC bar	°C	°C								
3/4"	15	-	-	3550	1.5	40	40	-10	50	PUR	321H36 <sub>1</sub>	2995	481865	8	9	2.1	3696
	15	-	-	3550	1.5	40	40	-10	50	PUR	321H36 <sub>1</sub>	4270	481000	8	8	2.1	3696
	18	100	6	9400	0.3	10	10	-10	100	NBR	321K36	8993	481180	4	5	1.1	7097
	18	100	6	9400	0.3	10	7	-10	75	NBR	321K36	8993	488980	2	2.5	1.1	7097
	18	100	6	9400	0.3	10	10	-10	100	FKM	321K3606	8993	481180	4	5	1.1	7097
	18	100	6	9400	0.3	10	7	-10	75	FKM	321K3606	8993	488980	2	2.5	1.1	7097
	20	135	8.1	9500	0.3	16	16	-10	100	NBR	E321G36	2995	481865	8	9	2.0	3442
	20	135	8.1	9500	0.3	16	16	-10	100	NBR	E321G36	4270	481000	8	8	2.0	3442
	20	135	8.1	9500	0.3	16	16	-10	100	FKM	E321G3606	2995	481865	8	9	2.0/14.1	3442
	20	135	8.1	9500	0.3	16	16	-10	120	FKM	E321G3606	4270	481000	8	8	2.0/14.1	3442
20	135	8.1	9500	0.3	16	16	-10	120	FKM	E321G3606	4270	486265	14	14	2.0/14.1	3442	

#### Notes:

1. Pilot seat disc in synthetic Ruby



**2 WAY VALVES**



For this page	Port size	Orifice (mm)	Kv (l/min)	MOPD (bar)	Fluid Temp (°C)	Amb Temp (°C)
From	3/4"	15	100	7	-10	-10
To	3/4"	20	135	40	120	50

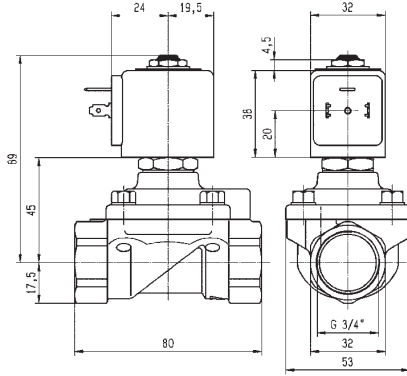

Drawing 3696

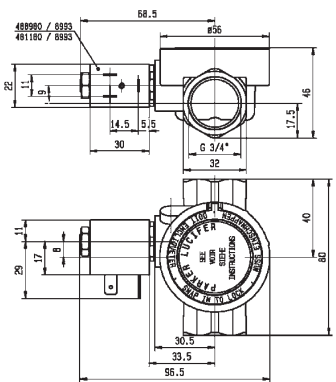

Drawing 7097

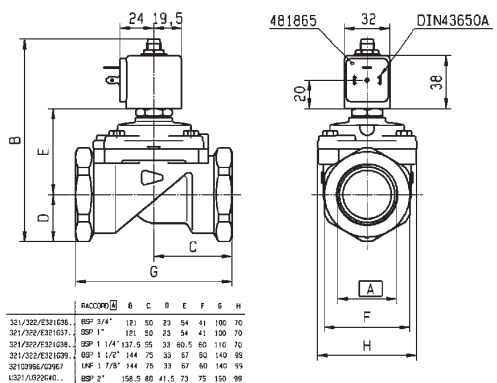

Drawing 3442



## 2 WAY VALVES

# 2/2

### VALVES FOR DRY OR LUBRICATED AIR, NEUTRAL GASES AND LIQUIDS PILOT OPERATED

BRASS

PIPE MOUNTING

**NORMALLY CLOSED**

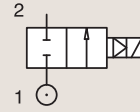

Port size	Orifice Ø	Flow factors			Operating Pressure Differential			Fluid Temp.		Seat Seal	Parker LUCIFER® Valves			IS	Power		Coil Group	Dwg. No.
		Kv l/min	KV m³/h	Qn l/min	Min bar	AC bar	DC bar	Min °C	Max °C		Valve Ref.	Housing Ref.	Coil Ref.		AC W	DC W		
1"	18	110	6.6	10150	0.3	10	10	-10	100	NBR	321K37	8993	481180	4	5	1.1	7098	
	18	110	6.6	10150	0.3	10	7	-10	75	NBR	321K37	8993	488980	2	2.5	1.1	7098	
	18	110	6.6	10150	0.3	10	10	-10	100	FKM	321K3706	8993	481180	4	5	1.1	7098	
	18	110	6.6	10150	0.3	10	7	-10	75	FKM	321K3706	8993	488980	2	2.5	1.1	7098	
	25	185	11.1	14100	0.3	-	10	-10	75	NBR	321G3790	2995	483580.01	*	-	0.5 to 3	7.0/8.0	3442
	25	185	11.1	14100	0.3	-	10	-10	75	NBR	321G3790	-	488660.01	*	-	0.3 to 3	7.0/8.0	3442
	25	185	11.1	14100	0.3	-	10	-10	75	NBR	321G3790	-	495910	*	-	0.3 to 3	7.0/8.0	3442
	25	180	10.8	14000	0.3	16	16	-10	100	NBR	E321G37	2995	481865	8	9	2.0	3442	
	25	180	10.8	14000	0.3	16	16	-10	100	NBR	E321G37	4270	481000	8	8	2.0	3442	
	25	180	10.8	14000	0.3	16	16	-10	100	FKM	E321G3706	2995	481865	8	9	2.0/14.1	3442	
	25	180	10.8	14000	0.3	16	16	-10	120	FKM	E321G3706	4270	481000	8	8	2.0/14.1	3442	
	25	180	10.8	14000	0.3	16	16	-10	120	FKM	E321G3706	4270	486265	14	14	2.0/14.1	3442	
	28	270	16.2	18000	0.3	16	16	-10	100	NBR	E321G38	2995	481865	8	9	2.0	3442	
	28	270	16.2	18000	0.3	16	16	-10	100	NBR	E321G38	4270	481000	8	8	2.0	3442	
	28	270	16.2	18000	0.3	16	16	-10	100	FKM	E321G3806	2995	481865	8	9	2.0	3442	
	28	270	16.2	18000	0.3	16	16	-10	120	FKM	E321G3806	4270	481000	8	8	2.0	3442	
	28	270	16.2	18000	0.3	16	16	-10	100	FKM	E321G3806	4270	486265	14	14	2.0	3442	



## 2 WAY VALVES



For this page	Port size	Orifice (mm)	Kv (l/min)	MOPD (bar)	Fluid Temp (°C)	Amb Temp (°C)
From	1"	18	110	7	-10	-10
To	1"	28	270	16	120	50

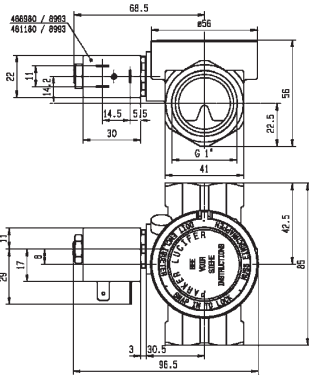

Drawing 7098

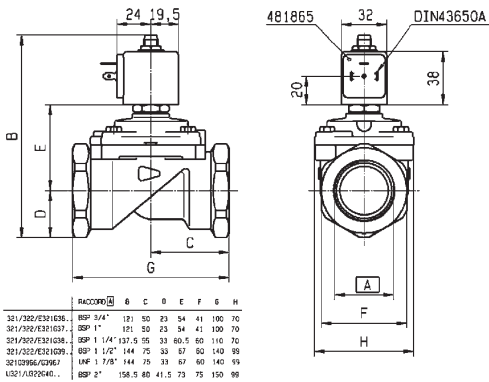

Drawing 3442

## 2 WAY VALVES

# 2/2

### VALVES FOR DRY OR LUBRICATED AIR, NEUTRAL GASES AND LIQUIDS PILOT OPERATED

#### BRASS

#### PIPE MOUNTING

#### NORMALLY CLOSED

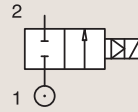

Port size	Orifice Ø	Flow factors			Operating Pressure Differential Max(MOPD)			Fluid Temp.		Seat Seal	Parker LUCIFER® Valves			IS	Power		Coil Group	Dwg. No.
		Kv l/min	KV m³/h	Qn l/min	Min bar	AC bar	DC bar	Min °C	Max °C		Valve Ref.	Housing Ref.	Coil Ref.		AC W	DC W		
1 1/2"	40	425	25.5	31500	0.5	-	10	-10	75	NBR	321G3990	2995	483580.01	*	-	0.5 to 3	7.0/8.0	8113
	40	425	25.5	31500	0.5	-	10	-10	75	NBR	321G3990	-	488660.01	*	-	0.3 to 3	7.0/8.0	8113
	40	425	25.5	31500	0.5	-	10	-10	75	NBR	321G3990	-	495910	*	-	0.3 to 3	7.0/8.0	8113
	40	420	25.2	31500	0.3	16	7	-10	100	NBR	E321G39 <sub>1</sub>	2995	481865	8	9	2.0	3442	
	40	420	25.2	31500	0.3	16	8.5	-10	100	NBR	E321G39 <sub>1</sub>	4270	481000	8	8	2.0	3442	
	40	420	25.2	31500	0.3	16	7	-10	100	FKM	E321G3906	2995	481865	8	9	2.0	3442	
	40	420	25.2	31500	0.3	16	8.5	-10	120	FKM	E321G3906	4270	481000	8	8	2.0	3442	
	40	420	25.2	31500	0.3	16	16	-10	100	FKM	E321G3906	4270	486265	14	14	2.0	3442	
2"	40	540	32.4	38100	0.5	-	10	-10	75	NBR	321G4090	2995	483580.01	*	-	0.5 to 3	7.0/8.0	8113
	40	540	32.4	38100	0.5	-	10	-10	75	NBR	321G4090	-	488660.01	*	-	0.3 to 3	7.0/8.0	8113
	40	540	32.4	38100	0.5	-	10	-10	75	NBR	321G4090	-	495910	*	-	0.3 to 3	7.0/8.0	8113
	40	540	32.4	40000	0.3	16	7	-10	100	NBR	E321G40 <sub>1</sub>	2995	481865	8	9	2.0	3442	
	40	540	32.4	40000	0.3	16	8.5	-10	100	NBR	E321G40 <sub>1</sub>	4270	481000	8	8	2.0	3442	
	40	540	32.4	40000	0.3	16	7	-10	100	FKM	E321G4006	2995	481865	8	9	2.0	3442	
	40	540	32.4	40000	0.3	16	8.5	-10	120	FKM	E321G4006	4270	481000	8	8	2.0	3442	
	40	540	32.4	40000	0.3	16	7	-10	120	FKM	E321G4006	4270	486265	14	14	2.0	3442	

#### Notes:

1. Pilot seat disc in synthetic Ruby



## 2 WAY VALVES



For this page	Port size	Orifice (mm)	Kv (l/min)	MOPD (bar)	Fluid Temp (°C)	Amb Temp (°C)
From	1 1/2"	40	420	7	-10	-10
To	2"	40	540	16	120	50

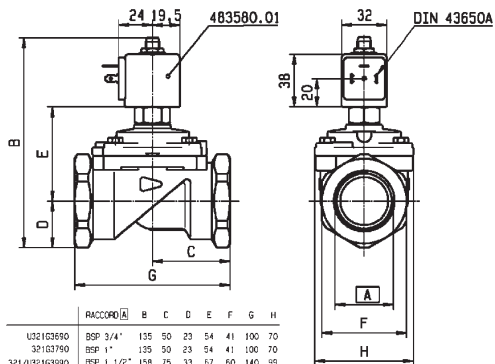

Drawing 8113

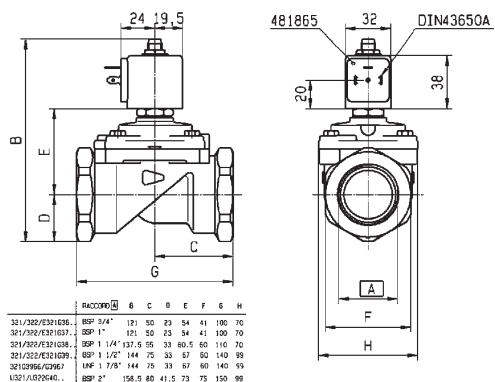

Drawing 3442

## 2 WAY VALVES

# 2/2

### VALVES FOR DRY OR LUBRICATED AIR, NEUTRAL GASES AND LIQUIDS PILOT OPERATED

BRASS  
PIPE MOUNTING

**NORMALLY OPEN**

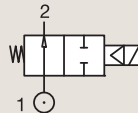

Port size	Orifice Ø	Flow factors			Operating Pressure Differential			Fluid Temp.		Seat Seal	Valve Order Number	Parker Valves	Coil Type	Power		Coil Group	Dwg. No.
		Kv l/min	KV m³/h	Qn m³/h	Min bar	Max(MOPD) DC bar	Min °C	Max °C	AC W					DC W			
3/8"	13	33	2	-	0.5	-	16	-10	90	NBR	366601 <sub>1</sub>	PM169.1IN	ZB16	-	12	20.1/20.2	052
	13	33	2	-	0.5	16	-	-10	90	NBR	366601 <sub>1</sub>	PM169.1IN	ZH14	9	-	20.1/20.2	052
1/2"	13	42	2.5	-	0.5	-	16	-10	90	NBR	366606 <sub>1</sub>	PM169.1AN	ZB16	-	12	20.1/20.2	049
	13	42	2.5	-	0.5	16	-	-10	90	NBR	366606 <sub>1</sub>	PM169.1AN	ZH14	9	-	20.1/20.2	049
3/4"	20	117	7	-	0.5	-	16	-10	90	NBR	366611 <sub>1</sub>	PM169.1CN	ZB16	-	12	20.1/20.2	050
	20	117	7	-	0.5	16	-	-10	90	NBR	366611 <sub>1</sub>	PM169.1CN	ZH14	9	-	20.1/20.2	050
1"	25	133	8	-	0.5	-	16	-10	90	NBR	366616 <sub>1</sub>	PM169.1DN	ZB16	-	12	20.1/20.2	051
	25	133	8	-	0.5	16	-	-10	90	NBR	366616 <sub>1</sub>	PM169.1DN	ZH14	9	-	20.1/20.2	051

**Notes:**

1. Valve only compatible with air and neutral gases

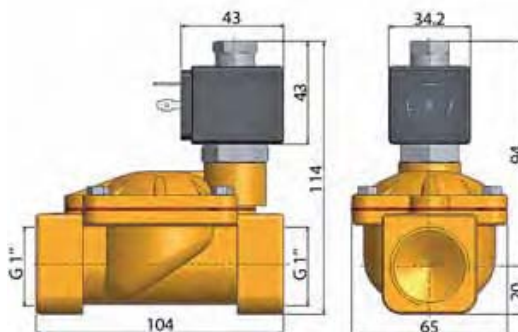

Drawing 051



## 2 WAY VALVES



For this page	Port size	Orifice (mm)	Kv (l/min)	MOPD (bar)	Fluid Temp (°C)	Amb Temp (°C)
From	3/8"	13	33	16	-10	-10
To	1"	25	133	16	90	50

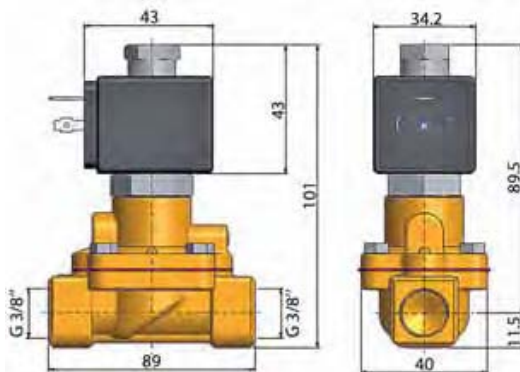

Drawing 052

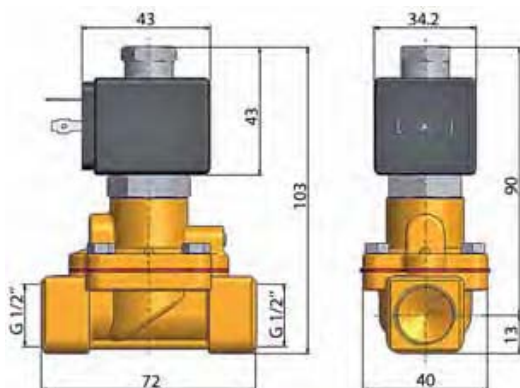

Drawing 049

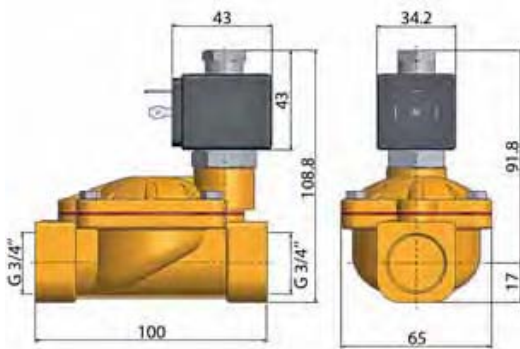

Drawing 050

## 2 WAY VALVES

# 2/2

## VALVES FOR DRY OR LUBRICATED AIR, NEUTRAL GASES AND LIQUIDS PILOT OPERATED

### BRASS

### PIPE MOUNTING

### NORMALLY OPEN

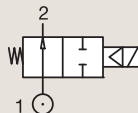

Port size	Orifice Ø	Flow factors			Operating Pressure Differential			Fluid Temp.		Seat Seal	Parker LUCIFER® Valves			Power		Coil Group	Dwg. No.
		Kv l/min	KV m³/h	Qn l/min	Min bar	Max(MOPD) AC bar	DC bar	Min °C	Max °C		Valve Ref.	Housing Ref.	Coil Ref.	AC W	DC W		
1/4"	8	36	2.16	1600	0.3	40	25	-10	100	NBR	322H71 <sub>12</sub>	2995	481865	8	9	2.0	3523
	8	36	2.16	1600	0.3	40	30	-10	100	NBR	322H71 <sub>12</sub>	4270	481000	8	8	2.0	3523
	8	36	2.16	1600	0.3	40	40	-10	100	NBR	322H71 <sub>12</sub>	4270	486265	14	14	2.0	3523
	8	36	2.16	1600	0.3	40	40	-10	100	FKM	322H7106 <sub>12</sub>	2995	481865	8	9	2.0/14.1	3523
	8	36	2.16	1600	0.3	40	40	-10	120	FKM	322H7106 <sub>12</sub>	4270	481000	8	8	2.0/14.1	3523
3/8"	8	36	2.16	1600	0.3	40	40	-10	140	FKM	322H7106 <sub>12</sub>	4270	486265	14	14	2.0/14.1	3523
	11	50	3	3240	0.3	40	40	-10	75	NBR	322H73 <sub>12</sub>	2995	481865	8	9	2.0	3523
	11	50	3	3240	0.3	40	40	-10	75	NBR	322H73 <sub>12</sub>	4270	481000	8	8	2.0	3523
	11	50	3	3240	0.3	40	40	-10	75	NBR	322H73 <sub>12</sub>	4270	486265	14	14	2.0	3523
	11	50	3	3240	0.3	40	40	-10	100	FKM	322H7306 <sub>12</sub>	2995	481865	8	9	2.0/14.1	3523
1/2"	11	50	3	3240	0.3	40	40	-10	100	FKM	322H7306 <sub>12</sub>	4270	481000	8	8	2.0/14.1	3523
	11	50	3	3240	0.3	40	40	-10	140	FKM	322H7306 <sub>12</sub>	4270	486265	14	14	2.0/14.1	3523
	15	60	3.6	3890	0.3	15	15	-10	100	NBR	322G75	2995	481865	8	9	2.1	3522
	15	60	3.6	3890	0.3	15	15	-10	100	NBR	322G75	4270	481000	8	8	2.1	3522
	15	60	3.6	3890	0.3	20	20	-10	100	FKM	322G7506 <sub>1</sub>	2995	481865	8	9	2.0	3522
	15	60	3.6	3890	0.3	20	20	-10	100	FKM	322G7506 <sub>1</sub>	4270	481000	8	8	2.0	3522
	15	60	3.6	3890	0.3	20	20	-10	100	FKM	322G7506 <sub>1</sub>	4270	486265	14	14	2.0	3522
	15	60	3.6	3150	1.5	40	40	-10	50	PUR	322H35 <sub>3</sub>	2995	481865	8	9	2.1	7569
	15	60	3.6	3150	1.5	40	40	-10	50	PUR	322H35 <sub>3</sub>	4270	481000	8	8	2.1	7569
	15	60	3.6	3890	0.3	40	40	-10	100	NBR	322H75 <sub>12</sub>	2995	481865	8	9	2.0	3522
	15	60	3.6	3890	0.3	40	40	-10	100	NBR	322H75 <sub>12</sub>	4270	481000	8	8	2.0	3522
	15	60	3.6	3890	0.3	40	40	-10	100	NBR	322H75 <sub>12</sub>	4270	486265	14	14	2.0	3522
	15	60	3.6	3890	0.3	40	40	-10	100	FKM	322H7506 <sub>12</sub>	2995	481865	8	9	2.0/14.1	3522
	15	60	3.6	3890	0.3	40	40	-10	120	FKM	322H7506 <sub>12</sub>	4270	481000	8	8	2.0/14.1	3522
	15	60	3.6	3890	0.3	40	40	-10	140	FKM	322H7506 <sub>12</sub>	4270	486265	14	14	2.0/14.1	3522

#### Notes:

1. Minimum pressure differential = 0.3 bar for opening and 0 bar for closing
2. Pilot seat disc in synthetic Ruby
3. Valve only compatible with air and neutral gases



## 2 WAY VALVES



For this page	Port size	Orifice (mm)	Kv (l/min)	MOPD (bar)	Fluid Temp (°C)	Amb Temp (°C)
From	1/4"	8	36	15	-10	-10
To	1/2"	15	60	40	140	50

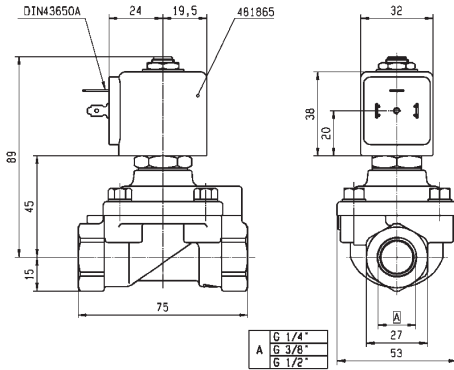

Drawing 3523

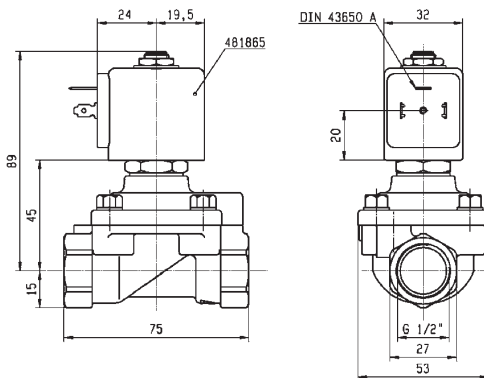

Drawing 3522

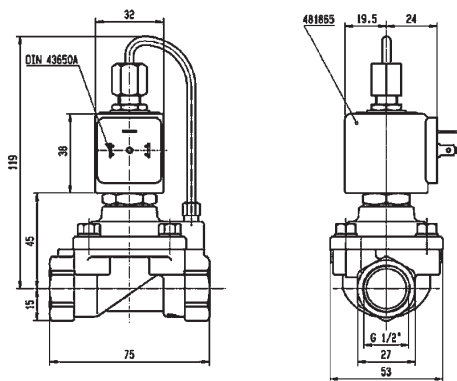

Drawing 7569

## 2 WAY VALVES

# 2/2

### VALVES FOR DRY OR LUBRICATED AIR, NEUTRAL GASES AND LIQUIDS PILOT OPERATED

#### BRASS

#### PIPE MOUNTING

#### NORMALLY OPEN

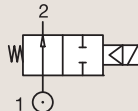

Port size	Orifice Ø	Flow factors			Operating Pressure Differential			Fluid Temp.		Seat Seal	Parker LUCIFER® Valves			Power		Coil Group	Dwg. No.
		Kv l/min	KV m³/h	Qn l/min	Min bar	AC bar	DC bar	Min °C	Max °C		Valve Ref.	Housing Ref.	Coil Ref.	AC W	DC W		
3/4"	15	-	-	3550	1.5	40	40	-10	50	PUR	322H36 <sub>12</sub>	2995	481865	8	9	2.1	7570
	15	-	-	3550	1.5	40	40	-10	50	PUR	322H36 <sub>12</sub>	4270	481000	8	8	2.1	7570
	20	135	8.1	9500	0.3	16	16	-10	100	NBR	322G36	2995	481865	8	9	2.1	3442
	20	135	8.1	9500	0.3	16	16	-10	100	NBR	322G36	4270	481000	8	8	2.1	3442
	20	135	8.1	9500	0.3	16	16	-10	100	FKM	322G3606	2995	481865	8	9	2.1	3442
	20	135	8.1	9500	0.3	16	16	-10	120	FKM	322G3606	4270	481000	8	8	2.1	3442
1"	25	180	10.8	14000	0.3	16	16	-10	100	NBR	322G37	2995	481865	8	9	2.1	3442
	25	180	10.8	14000	0.3	16	16	-10	100	NBR	322G37	4270	481000	8	8	2.1	3442
	25	180	10.8	14000	0.3	16	16	-10	100	FKM	322G3706	2995	481865	8	9	2.1	3442
	25	180	10.8	14000	0.3	16	16	-10	120	FKM	322G3706	4270	481000	8	8	2.1	3442
1 1/4"	28	270	16.2	18000	0.3	16	16	-10	100	NBR	322G38	2995	481865	8	9	2.1	3442
	28	270	16.2	18000	0.3	16	16	-10	100	NBR	322G38	4270	481000	8	8	2.1	3442
	28	270	16.2	18000	0.3	16	16	-10	100	FKM	322G3806	2995	481865	8	9	2.1	3442
	28	270	16.2	18000	0.3	16	16	-10	120	FKM	322G3806	4270	481000	8	8	2.1	3442
1 1/2"	40	420	25.2	31500	0.3	12	12	-10	100	NBR	322G39	2995	481865	8	9	2.1	3442
	40	420	25.2	31500	0.3	12	12	-10	100	NBR	322G39	4270	481000	8	8	2.1	3442
	40	420	25.2	31500	0.3	12	12	-10	100	FKM	322G3906	2995	481865	8	9	2.1	3442
	40	420	25.2	31500	0.3	12	12	-10	100	FKM	322G3906	4270	481000	8	8	2.1	3442
2"	40	540	32.4	40000	0.3	12	12	-10	100	NBR	322G40	2995	481865	8	9	2.1	3442
	40	540	32.4	40000	0.3	12	12	-10	100	NBR	322G40	4270	481000	8	8	2.1	3442
	40	540	32.4	40000	0.3	12	12	-10	100	FKM	322G4006	2995	481865	8	9	2.1	3442
	40	540	32.4	40000	0.3	12	12	-10	120	FKM	322G4006	4270	481000	8	8	2.1	3442

#### Notes:

1. Minimum pressure differential = 1.5 bar for opening and 0.3 bar for closing
2. Valve only compatible with air and neutral gases



## 2 WAY VALVES



For this page	Port size	Orifice (mm)	Kv (l/min)	MOPD (bar)	Fluid Temp (°C)	Amb Temp (°C)
From	3/4"	15	-	12	-10	-10
To	2"	40	540	40	120	50

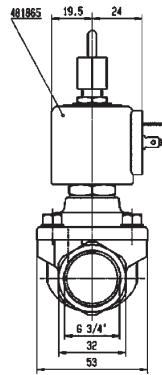
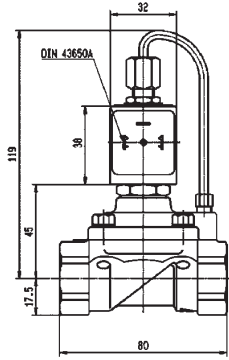

Drawing 7570

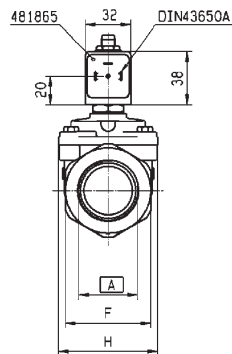
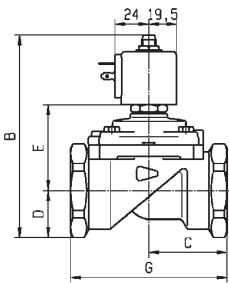

Drawing 3442

RACCORD	B	C	D	E	F	G	H	
311/322/E311E36..	BSP 3/4"	121	50	23	54	41	100	70
311/332/E321G37..	BSP 1"	121	50	23	54	41	100	70
311/330/E321G38..	BSP 1 1/4"	137.5	55	33	60.5	60	110	70
321/322/E321G29..	BSP 1 1/2"	144	75	33	67	60	140	95
321Q296/G296F	UNF 1 7/8"	144	75	33	67	60	140	95
U321/U320E40..	BSP 2"	158.5	80	41.5	73	75	150	99

## 2 WAY VALVES

# 2/2

## VALVES FOR DRY OR LUBRICATED AIR, NEUTRAL GASES AND LIQUIDS PILOT OPERATED

BRASS

PIPE MOUNTING

CONTROL BY ELECTRIC IMPULSE

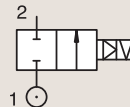

Port size	Orifice Ø	Flow factors			Operating Pressure Differential			Fluid Temp.		Seat Seal	Parker LUCIFER® Valves			Power		Coil Group	Dwg. No.
					Min	Max(MOPD)	DC bar	Min	Max		Valve Ref.	Housing Ref.	Coil Ref.	AC W	DC W		
BSP	mm	Kv l/min	KV m³/h	Qn l/min	bar	AC bar	DC bar	°C	°C								
1/4"	12	32	1.92	2150	0.3	12	-	-10	100	FKM	325K4106	4269	484990	11	-	4.0	7094
	12	32	1.92	2150	0.3	-	12	-10	100	FKM	325K4106	4269	485400	-	13	4.0	7094
3/8"	12	45	2.7	3050	0.3	12	-	-10	100	FKM	325K4306	4269	484990	11	-	4.0	7094
	12	45	2.7	3050	0.3	-	12	-10	100	FKM	325K4306	4269	485400	-	13	4.0	7094
1/2"	12	50	3	3400	0.3	12	-	-10	100	FKM	325K4506	4269	484990	11	-	4.0	7094
	12	50	3	3400	0.3	-	12	-10	100	FKM	325K4506	4269	485400	-	13	4.0	7094
3/4"	18	100	6	9400	0.3	12	-	-10	100	FKM	325K4606	4269	484990	11	-	4.0	7099
	18	100	6	9400	0.3	-	12	-10	100	FKM	325K4606	4269	485400	-	13	4.0	7099
1"	18	110	6.6	10150	0.3	12	-	-10	100	FKM	325K4706	4269	484990	11	-	4.0	7100
	18	110	6.6	10150	0.3	-	12	-10	100	FKM	325K4706	4269	485400	-	13	4.0	7100

## 2 WAY VALVES



For this page	Port size	Orifice (mm)	Kv (l/min)	MOPD (bar)	Fluid Temp (°C)	Amb Temp (°C)
From	1/4"	12	32	12	-10	-10
To	1"	18	110	12	100	50

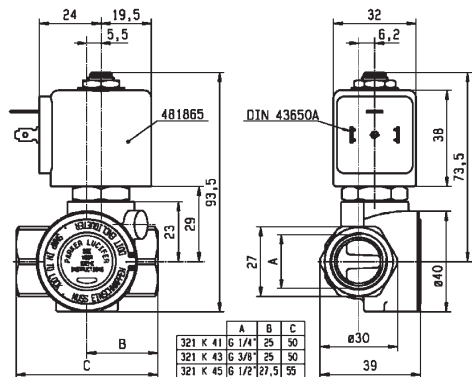

Drawing 7094

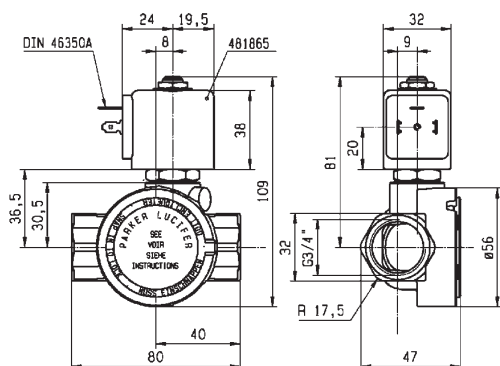

Drawing 7099

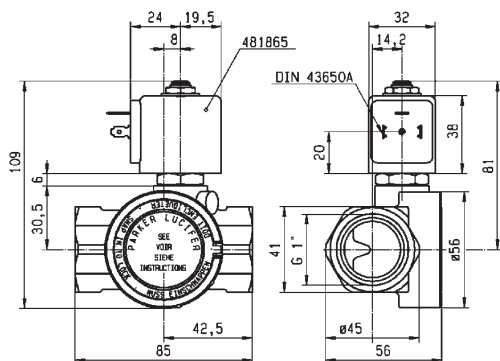

Drawing 7100



## 2 WAY VALVES

# 2/2

## VALVES FOR DRY OR LUBRICATED AIR, NEUTRAL GASES AND LIQUIDS PILOT OPERATED

### BRASS

#### SUB-BASE MOUNTING

#### NORMALLY CLOSED

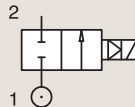

Port size	Orifice Ø mm	Flow factors			Operating Pressure Differential Min Max(MOPD)			Fluid Temp. Min Max		Seat Seal	Parker LUCIFER® Valves			Power		Coil Group	Dwg. No.
		Kv l/min	KV m³/h	Qn l/min	bar	AC bar	DC bar	°C	°C		Valve Ref.	Housing Ref.	Coil Ref.	AC W	DC W		
SB	14	-	-	2100	1.5	40	40	-10	50	PUR	321F35	2995	481865	8	9	2.0	3520
	14	-	-	2100	1.5	40	40	-10	50	PUR	321F35	2995	492425	14	14	2.0	3520
	14	-	-	2100	0	13	13	-10	50	PUR	421F35	2995	481865	8	9	2.1	3520
	14	45	2.7	2100	0.3	40	25	-10	100	NBR	E321F32 <sub>2</sub>	2995	481865	8	9	2.0	3520
	14	45	2.7	2100	0.3	40	30	-10	100	NBR	E321F32 <sub>2</sub>	4270	481000	8	8	2.0	3520
	14	45	2.7	2100	0.3	40	40	-10	100	NBR	E321F32 <sub>2</sub>	4270	486265	14	14	2.0	3520
	14	45	2.7	-	0.3	40	25	-10	100	FKM	E321F3202 <sub>1234</sub>	2995	481865	8	9	2.0	3520
	14	45	2.7	-	0.3	40	30	-10	120	FKM	E321F3202 <sub>1234</sub>	4270	481000	8	8	2.0	3520
14	45	2.7	-	0.3	40	40	-10	140	FKM	E321F3202 <sub>1234</sub>	4270	486265	14	14	2.0	3520	

#### Notes:

1. Minimum pressure differential = 0.3 bar for opening and 0 bar for closing
2. Pilot seat disc in synthetic Ruby
3. Valve only compatible with hydraulic oil and neutral liquids
4. With 4 position selector for controlled closure rate

### BRASS

#### SUB-BASE MOUNTING

#### NORMALLY OPEN

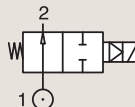

Port size	Orifice Ø mm	Flow factors			Operating Pressure Differential Min Max(MOPD)			Fluid Temp. Min Max		Seat Seal	Parker LUCIFER® Valves			Power		Coil Group	Dwg. No.
		Kv l/min	KV m³/h	Qn l/min	bar	AC bar	DC bar	°C	°C		Valve Ref.	Housing Ref.	Coil Ref.	AC W	DC W		
SB	14	-	-	2100	1.5	40	40	-10	50	PUR	322F35	2995	481865	8	9	2.1	7527
	14	46	2.76	-	0.3	40	40	-10	75	NBR	322F72 <sub>124</sub>	2995	481865	8	9	2.1	3520
	14	46	2.76	-	0.3	40	40	-10	75	NBR	322F72 <sub>124</sub>	4270	481000	8	8	2.1	3520
	14	45	2.7	-	0.3	40	40	0	100	FKM	322F7206 <sub>1234</sub>	2995	481865	8	9	2.1/14.1	3520
	14	45	2.7	-	0.3	40	40	0	120	FKM	322F7206 <sub>1234</sub>	4270	481000	8	8	2.1/14.1	3520

#### Notes:

1. Minimum pressure differential = 0.3 bar for opening and 0 bar for closing
2. Pilot seat disc in synthetic Ruby
3. Valve only compatible with hydraulic oil and neutral liquids
4. With 4 position selector for controlled closure rate



## 2 WAY VALVES



For this page	Port size	Orifice (mm)	Kv (l/min)	MOPD (bar)	Fluid Temp (°C)	Amb Temp (°C)
From	14 mm	14	-	13	-10	-10
To	14 mm	14	46	40	140	50

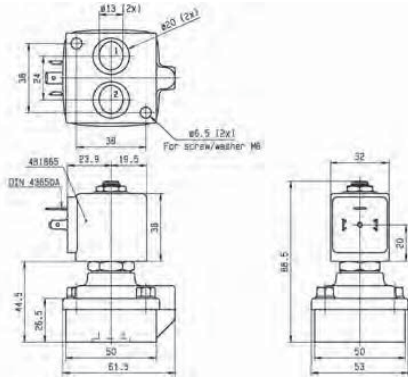

Drawing 3520

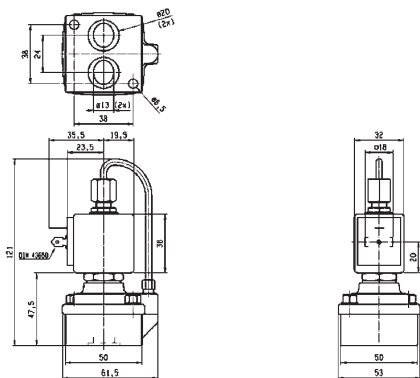

Drawing 7527

## 2 WAY VALVES

## 2 WAY VALVES



### VALVES FOR WATER AND NEUTRAL LIQUIDS



# 2/2

Actuation	Body	Function	Port Size	Orifice (mm)	Flow Factor Kv(l/min)	MOPD (bar)	Max Fluid Temp. (°C)	Page Parker Valves	Page Parker LUCIFER® Valves
Direct Operated	Brass/Pipe mounting	Normally Closed	1/8"	1.5 to 3	4.5	20	140	80	84
			1/4"	1.5 to 6	13	20	140	82	84
			3/8"	4 to 6	12	10	120	-	86
			1/2"	8.5 to 11	36	4	120	-	86
		Normally Open Control by Electric Impulse	1/4"	2.5	3	12	120	-	86
			1/4"	5	11	5	100	-	88
Brass/Sub-base mounting	Normally Closed	SB	2 to 2.5	3	15	140	90	-	
		5 mm	1.5 to 3	4.5	20	120	-	92	
Pilot Operated	Brass/Pipe mounting	Normally Closed	1/4"	11 to 12	32	12	120	-	98
			3/8"	11 to 13	50	20	140	94	98
			1/2"	11 to 13	50	20	140	94	100
			3/4"	18 to 20	140	20	140	94	102
			1"	18 to 28	270	20	140	94	104
			1 1/4"	35	420	10	140	96	-
			1 1/2"	40	500	16	140	96	104
			2"	40 to 50	620	16	140	96	104
			Normally Open	1/4"	12	32	12	120	-
		3/8"		12 to 13	50	20	140	106	108
		1/2"		12 to 15	60	20	140	106	108
		3/4"		18 to 20	140	20	140	106	108
		1"		18 to 25	180	20	140	106	110
		1 1/4"		35	420	10	140	106	-
		1 1/2"		40	500	12	140	106	110
		2"		50	620	10	140	106	-
		2 1/2"		65	1100	10	90	106	-
		3"	75	1334	10	90	106	-	
	Brass/Sub-base mounting	Normally Closed	14 mm	14	45	40	100	-	110

## 2 WAY VALVES

# 2/2

## VALVES FOR WATER AND NEUTRAL LIQUIDS

### DIRECT OPERATED



Commercial Equipment



Beverage Dispensing



Heating Systems

## BRASS PIPE MOUNTING

### NORMALLY CLOSED

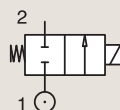

Port size	Orifice Ø	Flow factors			Operating Pressure Differential			Fluid Temp.		Seat Seal	Parker Valves			Power		Coil Group	Dwg. No.
		Kv	KV	Qn	Min	Max(MOPD)	DC	Min	Max		Valve Order Number	Valve Type	Coil Type	AC W	DC W		
BSP	mm	l/min	m <sup>3</sup> /h	m <sup>3</sup> /h	bar	AC bar	DC bar	°C	°C								
1/8"	1.5	1.5	0.09	-	0	20	-	-10	140	FKM	363378	PM146BV	ZB09	9	-	20.1/20.2	034
	1.5	1.5	0.09	-	0	-	18	-10	140	FKM	363378	PM146BV	ZB12	-	12	20.1/20.2	034
	2.2	2	0.12	-	0	10	-	-10	140	FKM	392349 <sup>12</sup>	161.4AV	KT09 115/50	9	-	22.0	043
	2.2	2	0.12	-	0	10	-	-10	140	FKM	392355 <sup>12</sup>	161.4AV	KT09 230/50	9	-	22.0	043
	2.2	2	0.12	-	0	10	-	-10	140	FKM	392335 <sup>12</sup>	161.4AV	KT09 24/50	9	-	22.0	043
	2.2	2	0.12	-	0	10	-	-10	140	FKM	392366 <sup>12</sup>	161.4AV	KT09 240/50	9	-	22.0	043
	2.2	2	0.12	-	0	-	6	-10	140	FKM	392372 <sup>12</sup>	161.4AV	KT10 12 DC	-	10	22.0	043
	2.2	2	0.12	-	0	-	6	-10	140	FKM	392370 <sup>12</sup>	161.4AV	KT10 24 DC	-	10	22.0	043
	2.5	3.3	0.20	-	0	10	-	-10	140	FKM	363380	PM146FV	ZB09	9	-	20.1/20.2	034
	2.5	3.3	0.20	-	0	-	5	-10	140	FKM	363380	PM146FV	ZB12	-	12	20.1/20.2	034
	2.8	2.9	0.17	-	0	6	-	-10	140	FKM	392389 <sup>12</sup>	161.4BV	KT09 115/60	9	-	22.0	043
	2.8	2.9	0.17	-	0	6	-	-10	140	FKM	392388 <sup>12</sup>	161.4BV	KT09 230/50	9	-	22.0	043
3	4.5	0.27	-	0	7	-	-10	140	FKM	363390	PM146HV	ZB09	9	-	20.1/20.2	034	
3	4.5	0.27	-	0	-	2	-10	140	FKM	363390	PM146HV	ZB12	-	12	20.1/20.2	034	

#### Notes:

1. Maximum pressure for steam: 4 Bar (140°C)
2. Ordering number is for an assembled valve and coil, with the voltage shown.



## 2 WAY VALVES



For this page	Port size	Orifice (mm)	Kv (l/min)	MOPD (bar)	Fluid Temp (°C)	Amb Temp (°C)
From	1/8"	1.5	1.5	2	-10	-10
To	1/8"	3	4.5	20	140	50

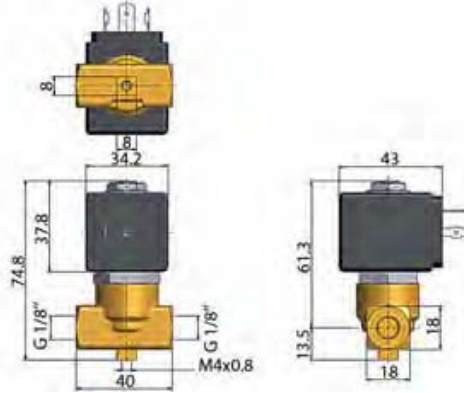

Drawing 034

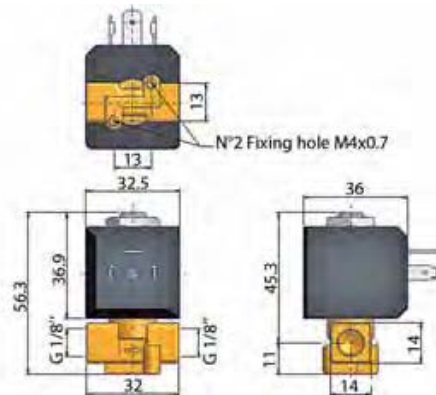

Drawing 043

**2 WAY VALVES**

# 2/2

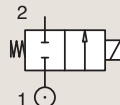
**VALVES FOR WATER AND NEUTRAL LIQUIDS**
**DIRECT OPERATED**
**BRASS**
**PIPE MOUNTING**
**NORMALLY CLOSED**

Port size	Orifice Ø	Flow factors			Operating Pressure Differential Max(MOPD)			Fluid Temp.		Seat Seal	Parker Valves			Power		Coil Group	Dwg. No.
		BSP	mm	Kv l/min	KV m³/h	Qn m³/h	Min bar	AC bar	DC bar		Min °C	Max °C	Valve Order Number	Valve Type	Coil Type		
1/4"	2.2	2	0.12	-	0	10	-	-10	140	FKM	392408 <sub>12</sub>	161.4EV	KT09 115/50	9	-	22.0	044
	2.2	2	0.12	-	0	10	-	-10	140	FKM	392408 <sub>12</sub>	161.4EV	KT09 115/60	9	-	22.0	044
	2.2	2	0.12	-	0	10	-	-10	140	FKM	392409 <sub>12</sub>	161.4EV	KT09 208-230/60	9	-	22.0	044
	2.2	2	0.12	-	0	10	-	-10	140	FKM	392395 <sub>12</sub>	161.4EV	KT09 230/50	9	-	22.0	044
	2.2	2	0.12	-	0	10	-	-10	140	FKM	392173 <sub>12</sub>	161.4EV	KT09 24/50	9	-	22.0	044
	2.2	2	0.12	-	0	10	-	-10	140	FKM	392396 <sub>12</sub>	161.4EV	KT09 240/50	9	-	22.0	044
	2.2	2	0.12	-	0	-	6	-10	140	FKM	392170 <sub>12</sub>	161.4EV	KT10 12V DC	-	10	22.0	044
	2.2	2	0.12	-	0	-	6	-10	140	FKM	392169 <sub>12</sub>	161.4EV	KT10 24 DC	-	10	22.0	044
	3	4.5	0.27	-	0	7	-	-10	140	FKM	363444	PM146YV	ZB09	9	-	20.1/20.2	035
	3	4.5	0.27	-	0	-	2	-10	140	FKM	363444	PM146YV	ZB12	-	12	20.1/20.2	035
	4.5	9	0.53	-	0	6	-	-10	140	FKM	363457	PM146.3KV	ZB14	14	-	20.2	035
	4.5	9	0.53	-	0	-	2.5	-10	140	FKM	363457	PM146.3KV	ZB16	-	16	20.2	035
	6	13	0.75	-	0	6	-	-10	140	FKM	363467	PM146.3ABV	ZB14	14	-	20.2	035
	6	13	0.75	-	0	-	1	-10	140	FKM	363467	PM146.3ABV	ZB16	-	16	20.2	035

**Notes:**

1. Maximum pressure for steam: 4 Bar (140°C)
2. Ordering number is for an assembled valve and coil, with the voltage shown.

## 2 WAY VALVES



For this page	Port size	Orifice (mm)	Kv (l/min)	MOPD (bar)	Fluid Temp (°C)	Amb Temp (°C)
From	1/4"	2.2	2	1	-10	-10
To	1/4"	6	13	10	140	50

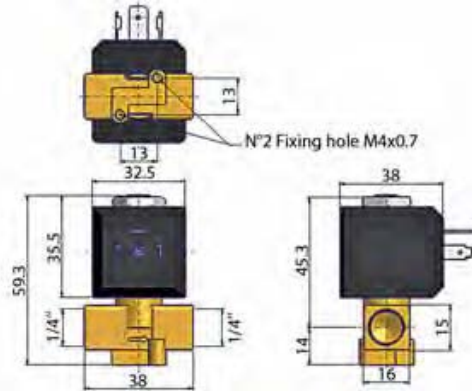

Drawing 044

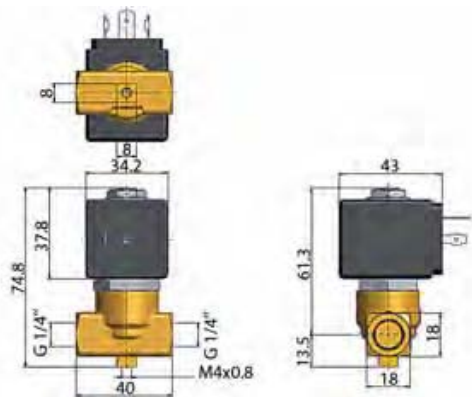

Drawing 035

## 2 WAY VALVES

# 2/2

## VALVES FOR WATER AND NEUTRAL LIQUIDS DIRECT OPERATED

### BRASS PIPE MOUNTING

### NORMALLY CLOSED

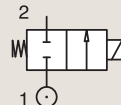

Port size	Orifice Ø	Flow factors			Operating Pressure Differential			Fluid Temp.		Seat Seal	Parker LUCIFER® Valves			Power		Coil Group	Dwg. No.
					Min	Max(MOPD)	DC bar	Min	Max		Valve Ref.	Housing Ref.	Coil Ref.	AC W	DC W		
					bar	AC bar	DC bar	°C	°C								
1/8"	1.5	0.9	0.05	70	0	20	12	-10	75	FKM	121M14	8993	481180	4	5	1.1	3382
	1.5	0.9	0.05	70	0	20	4	-10	75	FKM	121M14	8993	488980	2	2.5	1.1	3382
	2	2	0.12	125	0	10	7	-10	75	FKM	121M13	8993	481180	4	5	1.1	3382
	2	2	0.12	125	0	10	2.5	-10	75	FKM	121M13	8993	488980	2	2.5	1.1	3382
1/4"	1.5	1.5	0.09	80	0	20	20	-10	100	FKM	E121K0402	2995	481865	8	9	2.0/3.0	3510
	1.5	1.5	0.09	80	0	20	20	-10	120	FKM	E121K0402	4270	481000	8	8	2.0/3.0	3510
	2.5	3.5	0.21	220	0	14	7	-10	100	FKM	121K0706	2995	481865	8	9	2.0	3510
	2.5	3.5	0.21	220	0	14	9	-10	120	FKM	121K0706	4270	481000	8	8	2.0	3510
	2.5	3.5	0.21	220	0	14	14	-10	120	FKM	121K0706	4270	486265	14	14	2.0	3510
	3	4.5	0.27	320	0	10	7	-10	100	FKM	E121K0302	2995	481865	8	9	2.0	3510
	3	4.5	0.27	320	0	10	8.5	-10	120	FKM	E121K0302	4270	481000	8	8	2.0	3510
	3	4.5	0.27	320	0	10	7	-10	100	FKM	E121K0302	4270	486265	14	14	2.0	3510
	3	4.5	0.27	320	0	10	7	-10	100	FKM	E121K0352 <sub>1</sub>	2995	481865	8	9	2.0	3510
	3	4.5	0.27	320	0	10	8.5	-10	120	FKM	E121K0352 <sub>1</sub>	4270	481000	8	8	2.0	3510
	3	4.5	0.27	320	0	10	10	-10	120	FKM	E121K0352 <sub>1</sub>	4270	486265	14	14	2.0	3510
	4	7.5	0.45	480	0	10	4	-10	100	FKM	121K02	2995	481865	8	9	2.0	3510
	4	7.5	0.45	480	0	10	5	-10	120	FKM	121K02	4270	481000	8	8	2.0	3510
	4	7.5	0.45	480	0	10	10	-10	120	FKM	121K02	4270	486265	14	14	2.0	3510
	4	7.5	0.45	480	0	10	4	-10	100	FKM	121K0250 <sub>1</sub>	2995	481865	8	9	2.0	3510
	4	7.5	0.45	480	0	10	5	-10	120	FKM	121K0250 <sub>1</sub>	4270	481000	8	8	2.0	3510
	4	7.5	0.45	480	0	10	10	-10	120	FKM	121K0250 <sub>1</sub>	4270	486265	14	14	2.0	3510
	5	11	0.66	750	0	7	2	-10	100	FKM	121K01	2995	481865	8	9	2.0/14.2	3510
	5	11	0.66	750	0	7	2.8	-10	120	FKM	121K01	4270	481000	8	8	2.0/14.2	3510
	5	11	0.66	750	0	7	5	-10	120	FKM	121K01	4270	486265	14	14	2.0/14.2	3510
	5	11	0.66	750	0	7	2	-10	100	FKM	121K0106	2995	481865	8	9	2.0	3510
	5	11	0.66	750	0	7	2.8	-10	120	FKM	121K0106	4270	481000	8	8	2.0	3510
	5	11	0.66	750	0	7	5	-10	120	FKM	121K0106	4270	486265	14	14	2.0	3510
	5	11	0.66	750	0	7	2	-10	100	FKM	121K0150 <sub>1</sub>	2995	481865	8	9	2.0	3510
5	11	0.66	750	0	7	2.8	-10	120	FKM	121K0150 <sub>1</sub>	4270	481000	8	8	2.0	3510	
5	11	0.66	750	0	7	5	-10	120	FKM	121K0150 <sub>1</sub>	4270	486265	14	14	2.0	3510	

#### Notes:

1. With manual override



2 WAY VALVES



For this page	Port size	Orifice (mm)	Kv (l/min)	MOPD (bar)	Fluid Temp (°C)	Amb Temp (°C)
From	1/8"	1.5	0.9	2	-10	-10
To	1/4"	5	11	20	120	50

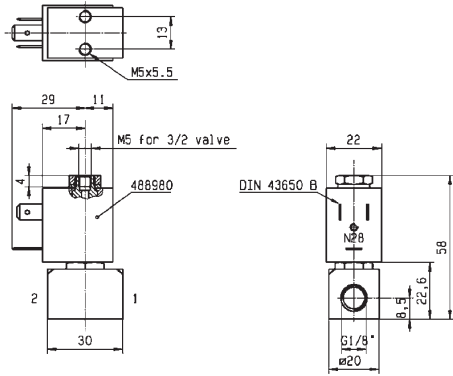

Drawing 3382

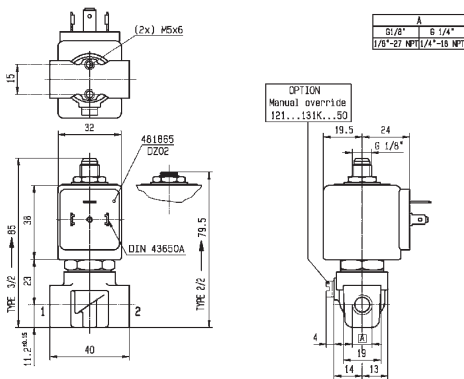

Drawing 3510

**2 WAY VALVES**

# 2/2

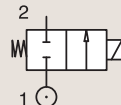
**VALVES FOR WATER AND NEUTRAL LIQUIDS**
**DIRECT OPERATED**
**BRASS**
**PIPE MOUNTING**
**NORMALLY CLOSED**

Port size	Orifice Ø	Flow factors			Operating Pressure Differential			Fluid Temp.		Seat Seal	Parker LUCIFER® Valves			Power		Coil Group	Dwg. No.
					Min	Max(MOPD)		Min	Max		Valve Ref.	Housing Ref.	Coil Ref.	AC W	DC W		
						bar	AC bar										
3/8"	4	7.5	0.45	480	0	10	4	-10	100	FKM	121K3206	2995	481865	8	9	2.0	3551
	4	7.5	0.45	480	0	10	5	-10	120	FKM	121K3206	4270	481000	8	8	2.0	3551
	4	7.5	0.45	480	0	10	10	-10	120	FKM	121K3206	4270	486265	14	14	2.0	3551
	5	11	0.66	750	0	7	2	-10	100	FKM	121K3106	2995	481865	8	9	2.0	3551
	5	11	0.66	750	0	7	2.8	-10	120	FKM	121K3106	4270	481000	8	8	2.0	3551
	5	11	0.66	750	0	7	5	-10	120	FKM	121K3106	4270	486265	14	14	2.0	3551
	6	12	0.72	1100	0	5	1.1	-10	100	FKM	121K3306	2995	481865	8	9	2.0/14.2	3551
	6	12	0.72	1100	0	5	1.5	-10	120	FKM	121K3306	4270	481000	8	8	2.0/14.2	3551
1/2"	6	12	0.72	1100	0	5	3	-10	120	FKM	121K3306	4270	486265	14	14	2.0/14.2	3551
	8.5	25	1.5	1600	0	1.1	0.5	-10	100	FKM	E121K46	2995	481865	8	9	2.0	3427
	8.5	25	1.5	1600	0	2.2	0.5	-10	120	FKM	E121K46	4270	481000	8	8	2.0	3427
	8.5	25	1.5	1600	0	4	1.2	-10	120	FKM	E121K46	4270	486265	14	14	2.0	3427
	11	36	2.16	2500	0	0.7	0.3	-10	100	FKM	E121K45	2995	481865	8	9	2.0	3427
	11	36	2.16	2500	0	1.2	0.35	-10	120	FKM	E121K45	4270	481000	8	8	2.0	3427
	11	36	2.16	2500	0	2.5	0.7	-10	120	FKM	E121K45	4270	486265	14	14	2.0	3427

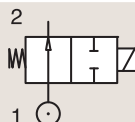
**BRASS**
**PIPE MOUNTING**
**NORMALLY OPEN**

Port size	Orifice Ø	Flow factors			Operating Pressure Differential			Fluid Temp.		Seat Seal	Parker LUCIFER® Valves			Power		Coil Group	Dwg. No.
					Min	Max(MOPD)		Min	Max		Valve Ref.	Housing Ref.	Coil Ref.	AC W	DC W		
						bar	AC bar										
1/4"	2.5	3	0.18	180	0	12	12	-10	100	FKM	122K8306	2995	481865	8	9	2.0	3510
	2.5	3	0.18	180	0	12	12	-10	120	FKM	122K8306	4270	481000	8	8	2.0	3510
	2.5	3	0.18	180	0	12	12	-10	120	FKM	122K8306	4270	486265	14	14	2.0	3510



## 2 WAY VALVES



For this page	Port size	Orifice (mm)	Kv (l/min)	MOPD (bar)	Fluid Temp (°C)	Amb Temp (°C)
From	1/4"	2.5	3	0.3	-10	-10
To	1/2"	11	36	12	120	50

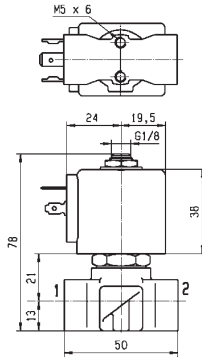

WEIGHT : 215 gr

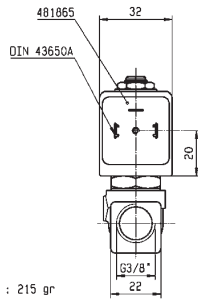

Drawing 3551

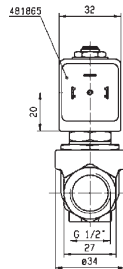
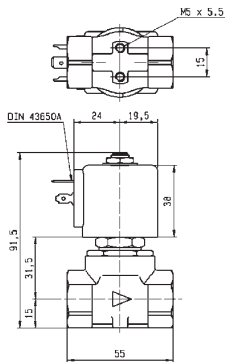

Drawing 3427

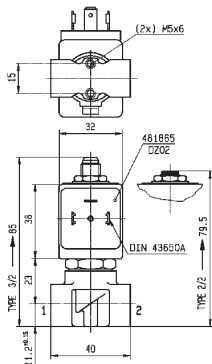

	A
G 1/8"	B 1/4"
G 1/8"-37 MP1/4"-18 MP1	

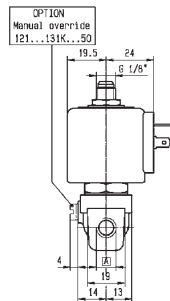

OPTION  
Manual override  
121...131K...50



Drawing 3510

## 2 WAY VALVES

# 2/2

## VALVES FOR WATER AND NEUTRAL LIQUIDS

### DIRECT OPERATED

BRASS

PIPE MOUNTING

CONTROL BY ELECTRIC IMPULSE

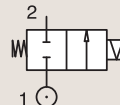

Port size	Orifice Ø	Flow factors			Operating Pressure Differential			Fluid Temp.		Seat Seal	Parker LUCIFER® Valves			Power		Coil Group	Dwg. No.
											Valve Ref.	Housing Ref.	Coil Ref.	AC W	DC W		
BSP	mm	Kv l/min	KV m³/h	Qn l/min	bar	AC bar	DC bar	°C	°C								
1/4"	5	11	0.66	750	0	5	-	-10	100	FKM	125K01	4269	484990	11	-	4.0	8296
	5	11	0.66	750	0	-	1.5	-10	100	FKM	125K01	4269	485400	-	13	4.0	8296

## 2 WAY VALVES



For this page	Port size	Orifice (mm)	Kv (l/min)	MOPD (bar)	Fluid Temp (°C)	Amb Temp (°C)
From	1/4"	5	11	1.5	-10	-10
To	1/4"	5	11	5	100	50

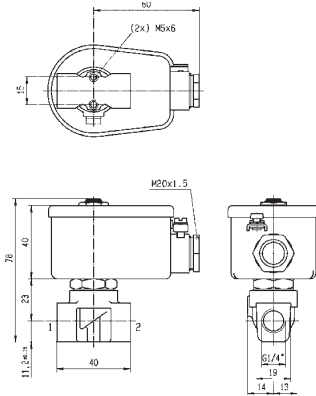

Drawing 8296

## 2 WAY VALVES

# 2/2

## VALVES FOR WATER AND NEUTRAL LIQUIDS

### DIRECT OPERATED

BRASS

SUB-BASE MOUNTING

**NORMALLY CLOSED**

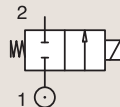

Port size	Orifice Ø mm	Flow factors			Operating Pressure Differential			Fluid Temp.		Seat Seal	Parker Valves			Power		Coil Group	Dwg. No.
		Kv l/min	KV m <sup>3</sup> /h	Qn m <sup>3</sup> /h	Min bar	Max AC bar	DC bar	Min °C	Max °C		Valve Order Number	Valve Type	Coil Type	AC W	DC W		
SB	2	2	0.12	-	0	15	-	-10	140	FKM	360469	PM125BV	ZB09	9	-	20.1/20.2	007
	2.5	3	0.18	-	0	10	-	-10	140	FKM	397146J	PM125CV.2	ZB09	9	-	20.1/20.2	007

## 2 WAY VALVES



For this page	Port size	Orifice (mm)	Kv (l/min)	MOPD (bar)	Fluid Temp (°C)	Amb Temp (°C)
From	SB	2	2	10	-10	-10
To	SB	2.5	3	15	140	50

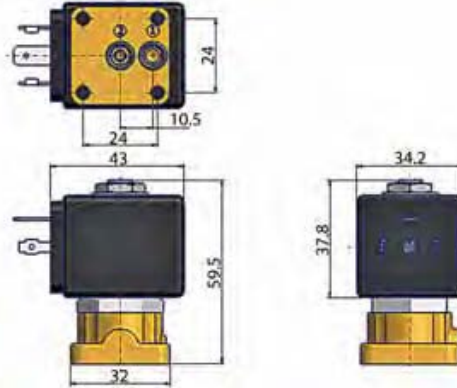

Drawing 007

## 2 WAY VALVES

# 2/2

## VALVES FOR WATER AND NEUTRAL LIQUIDS

### DIRECT OPERATED

BRASS

SUB-BASE MOUNTING

**NORMALLY CLOSED**

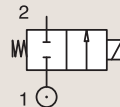

Port size	Orifice Ø mm	Flow factors			Operating Pressure Differential			Fluid Temp.		Seat Seal	Parker LUCIFER® Valves			Power		Coil Group	Dwg. No.
					Min	Max(MOPD)		Min	Max		Valve Ref.	Housing Ref.	Coil Ref.	AC W	DC W		
						AC bar	DC bar										
SB	1.5	1.5	0.09	80	0	20	20	-10	100	FKM	E121F4406	2995	481865	8	9	2.0	3509
	1.5	1.5	0.09	80	0	20	20	-10	120	FKM	E121F4406	4270	481000	8	8	2.0	3509
	1.5	1.5	0.09	80	0	20	20	-10	120	FKM	E121F4406	4270	486265	14	14	2.0	3509
	3	4.5	0.27	320	0	10	7	-10	100	FKM	E121F4302	2995	481865	8	9	2.0/3.0	3509
	3	4.5	0.27	320	0	10	8.5	-10	120	FKM	E121F4302	4270	481000	8	8	2.0/3.0	3509
	3	4.5	0.27	320	0	10	10	-10	120	FKM	E121F4302	4270	486265	14	14	2.0/3.0	3509

**2 WAY VALVES**



For this page	Port size	Orifice (mm)	Kv (l/min)	MOPD (bar)	Fluid Temp (°C)	Amb Temp (°C)
From	5 mm	1.5	1.5	7	-10	-10
To	5 mm	3	4.5	20	120	50

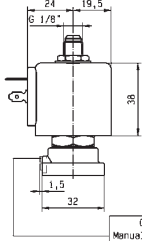
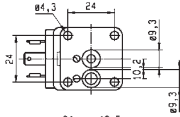

OPTION  
Manual override  
121...131F...50

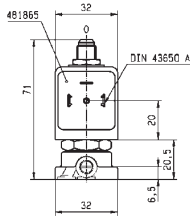

Drawing 3509

## 2 WAY VALVES

# 2/2

## VALVES FOR WATER AND NEUTRAL LIQUIDS

### PILOT OPERATED



Commercial Equipment



Industrial Equipment



Medical / Instrumentation

### BRASS PIPE MOUNTING

#### NORMALLY CLOSED

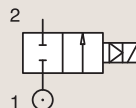

Port size	Orifice Ø	Flow factors			Operating Pressure Differential			Fluid Temp.		Seat Seal	Parker Valves			Power		Coil Group	Dwg. No.
		Kv l/min	KV m³/h	Qn m³/h	Min bar	Max(MOPD) AC bar	DC bar	Min °C	Max °C		Valve Order Number	Valve Type	Coil Type	AC W	DC W		
3/8"	13	50	3	-	0.1	10	10	-10	140	EPDM	443778W <sub>1</sub>	7321BIH00	481865	8	9	2.0	028
	13	50	3	-	0.1	20	20	-10	90	NBR	443776W	7321BIN00	481865	8	9	2.0	028
	13	50	3	-	0.1	20	20	-10	90	NBR	443777W <sub>2</sub>	7321BIN01	481865	8	9	2.0	028
	13	50	3	-	0.1	20	20	-10	140	FKM	444492W	7321BIV00	481865	8	9	2.0	028
1/2"	13	50	3	-	0.1	10	10	-10	140	EPDM	443781W <sub>1</sub>	7321BAH00	481865	8	9	2.0	028
	13	50	3	-	0.1	20	20	-10	90	NBR	443779W	7321BAN00	481865	8	9	2.0	028
	13	50	3	-	0.1	20	20	-10	90	NBR	443780W <sub>2</sub>	7321BAN01	481865	8	9	2.0	028
	13	50	3	-	0.1	20	20	-10	140	FKM	444494W	7321BAV00	481865	8	9	2.0	028
3/4"	20	140	8.4	-	0.1	10	10	-10	140	EPDM	443785W <sub>1</sub>	7321BCH00	481865	8	9	2.0	057
	20	140	8.4	-	0.1	20	20	-10	90	NBR	443782W	7321BCN00	481865	8	9	2.0	057
	20	140	8.4	-	0.1	10	10	-10	90	NBR	443783W <sub>2</sub>	7321BCN01	481865	8	9	2.0	057
	20	140	8.4	-	0.1	20	20	-10	140	FKM	444497W	7321BCV00	481865	8	9	2.0	057
1"	25	160	9.6	-	0.1	10	10	-10	140	EPDM	443789W <sub>1</sub>	7321BDH00	481865	8	9	2.0	057
	25	160	9.6	-	0.1	20	20	-10	90	NBR	443786W	7321BDN00	481865	8	9	2.0	057
	25	160	9.6	-	0.1	10	10	-10	90	NBR	443787W <sub>2</sub>	7321BDN01	481865	8	9	2.0	057
	25	160	9.6	-	0.1	20	20	-10	140	FKM	443804W	7321BDV00	481865	8	9	2.0	057

#### Notes:

1. Maximum pressure for steam: 4 Bar (140°C)
2. With manual override



## 2 WAY VALVES



For this page	Port size	Orifice (mm)	Kv (l/min)	MOPD (bar)	Fluid Temp (°C)	Amb Temp (°C)
From	3/8"	13	50	10	-10	-10
To	1"	25	160	20	140	50

G	A		B		C	
NPT	mm	inch	mm	inch	mm	inch
3/8"	65	2.56	95.5	3.76	40	1.57
1/2"	72	2.83	107.5	4.23	46	1.81

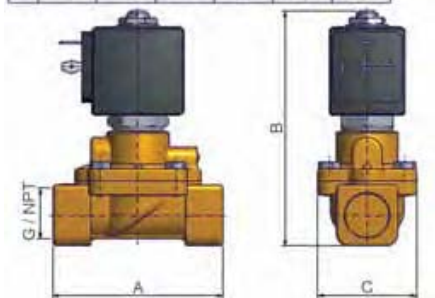

Drawing 028

G	A		B		C	
NPT	mm	inch	mm	inch	mm	inch
3/4"	100	3.94	127	5.00	65	2.56
1"	104	4.09	132.5	5.22	65	2.56

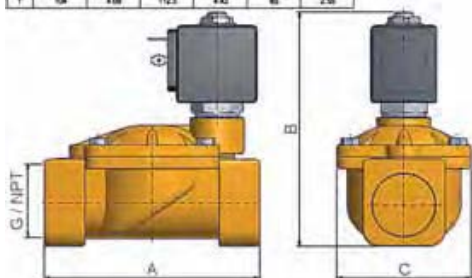

Drawing 057

## 2 WAY VALVES

# 2/2

## VALVES FOR WATER AND NEUTRAL LIQUIDS

### PILOT OPERATED

### BRASS

### PIPE MOUNTING

### NORMALLY CLOSED

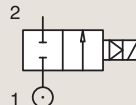

Port size	Orifice Ø	Flow factors			Operating Pressure Differential			Fluid Temp.		Seat Seal	Parker Valves			Power		Coil Group	Dwg. No.
		Kv l/min	KV m³/h	Qn m³/h	Min bar	Max (MOPD) DC bar	Min °C	Max °C	Valve Order Number		Valve Type	Coil Type	AC W	DC W			
1 1/4"	35	420	25.2	-	0.1	10	10	-10	140	EPDM	443793W <sub>1</sub>	7321BEH00	481865	8	9	2.0	058
	35	420	25.2	-	0.1	10	10	-10	90	NBR	443790W	7321BEN00	481865	8	9	2.0	058
	35	420	25.2	-	0.1	5	5	-10	90	NBR	443791W <sub>2</sub>	7321BEN01	481865	8	9	2.0	058
1 1/2"	40	500	30	-	0.1	10	10	-10	140	EPDM	443797W <sub>1</sub>	7321BFH00	481865	8	9	2.0	058
	40	500	30	-	0.1	10	10	-10	90	NBR	443794W	7321BFN00	481865	8	9	2.0	058
	40	500	30	-	0.1	5	5	-10	90	NBR	443795W <sub>2</sub>	7321BFN01	481865	8	9	2.0	058
2"	50	620	37.2	-	0.1	10	10	-10	140	EPDM	443801W <sub>1</sub>	7321BGH00	481865	8	9	2.0	058
	50	620	37.2	-	0.1	10	10	-10	90	NBR	443798W	7321BGN00	481865	8	9	2.0	058
	50	620	37.2	-	0.1	5	5	-10	90	NBR	443799W <sub>2</sub>	7321BGN01	481865	8	9	2.0	058

#### Notes:

1. Maximum pressure for steam: 4 Bar (140°C)
2. With manual override



## 2 WAY VALVES



For this page	Port size	Orifice (mm)	Kv (l/min)	MOPD (bar)	Fluid Temp (°C)	Amb Temp (°C)
From	1 1/4"	35	420	5	-10	-10
To	2"	50	620	10	140	50

G	A		B		C	
NPT	mm	inch	mm	inch	mm	inch
1/4"	48.3	1.90	126	5.00	102	4.02
1/2"	76.2	3.00	152	6.00	127	5.00
3/4"	101.6	4.00	178	7.00	152	6.00
1"	127.0	5.00	203	8.00	178	7.00

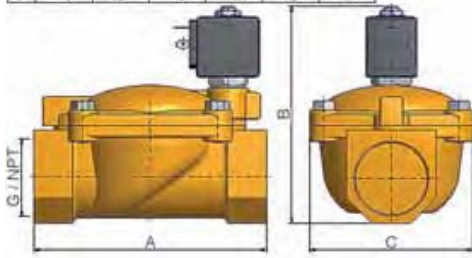

Drawing 058

## 2 WAY VALVES

# 2/2

## VALVES FOR WATER AND NEUTRAL LIQUIDS PILOT OPERATED

### BRASS PIPE MOUNTING

### NORMALLY CLOSED

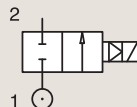

Port size	Orifice Ø	Flow factors			Operating Pressure Differential			Fluid Temp.		Seat Seal	Parker LUCIFER® Valves			Power		Coil Group	Dwg. No.
		Kv l/min	KV m³/h	Qn l/min	Min bar	Max(MOPD) AC bar	DC bar	Min °C	Max °C		Valve Ref.	Housing Ref.	Coil Ref.	AC W	DC W		
1/4"	11	28	1.68	1800	0.2	10	3	-10	100	NBR	E321K10	2995	481865	8	9	2.0	3429
	11	28	1.68	1800	0.2	10	4	-10	100	NBR	E321K10	4270	481000	8	8	2.0	3429
	12	30	1.8	2150	0.3	10	10	-10	100	NBR	321K31	8993	481180	4	5	1.1	7093
	12	30	1.8	2150	0.3	10	7	-10	75	NBR	321K31	8993	488980	2	2.5	1.1	7093
	12	32	1.92	2150	0.3	12	12	-10	100	FKM	321K4106	2995	481865	8	9	2.1/3.0	7094
	12	32	1.92	2150	0.3	12	12	-10	120	FKM	321K4106	4270	481000	8	8	2.1/3.0	7094
3/8"	11	36	2.16	2500	0.2	10	4	-10	100	NBR	E321K13	4270	481000	8	8	2.0	3429
	11	36	2.16	2500	0.2	10	10	-10	100	NBR	E321K13	4270	486265	14	14	2.0	3429
	11	36	2.16	2500	0.2	10	-	-10	100	NBR	E321K1314	2995	483466	8 to 11	-	2.0	3429
	11	36	2.16	2500	0.2	10	10	-10	100	NBR	E321K1314	4270	486265	14	14	2.0	3429
	12	45	2.7	3050	0.3	10	10	-10	100	NBR	321K33	8993	481180	4	5	1.1	7093
	12	45	2.7	3050	0.3	10	7	-10	75	NBR	321K33	8993	488980	2	2.5	1.1	7093
	12	45	2.7	3050	0.3	12	12	-10	100	FKM	321K4306	2995	481865	8	9	2.1/3.0	7094
	12	45	2.7	3050	0.3	12	12	-10	120	FKM	321K4306	4270	481000	8	8	2.1/3.0	7094

## 2 WAY VALVES



For this page	Port size	Orifice (mm)	Kv (l/min)	MOPD (bar)	Fluid Temp (°C)	Amb Temp (°C)
From	1/4"	11	28	3	-10	-10
To	3/8"	12	45	12	120	50

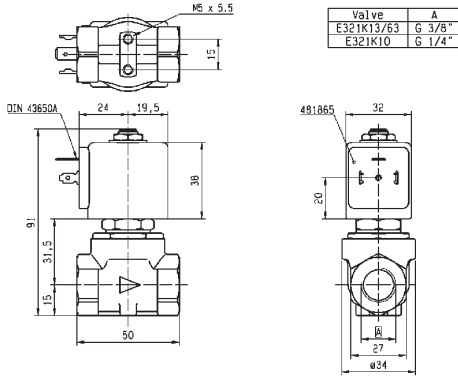

Drawing 3429

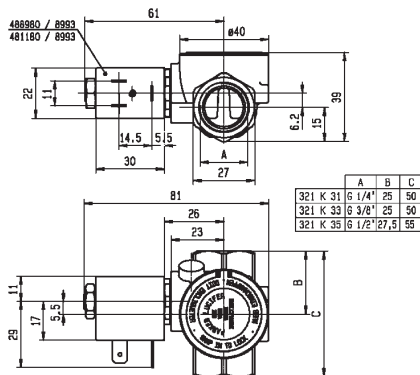

Drawing 7093

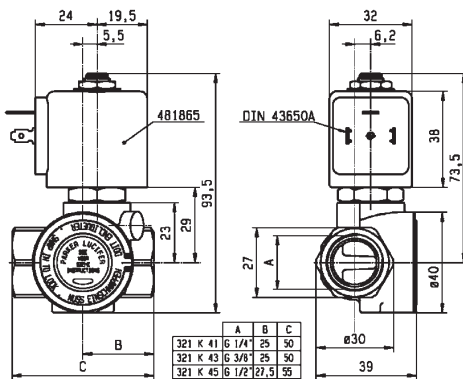

Drawing 7094

## 2 WAY VALVES

# 2/2

## VALVES FOR WATER AND NEUTRAL LIQUIDS

### PILOT OPERATED

### BRASS

### PIPE MOUNTING

### NORMALLY CLOSED

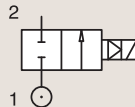

Port size	Orifice Ø	Flow factors			Operating Pressure Differential			Fluid Temp.		Seat Seal	Parker LUCIFER® Valves			Power		Coil Group	Dwg. No.
		Kv l/min	KV m³/h	Qn l/min	Min bar	Max(MOPD) AC bar	DC bar	Min °C	Max °C		Valve Ref.	Housing Ref.	Coil Ref.	AC W	DC W		
1/2"	11	36	2.16	2500	0.2	10	3	-10	100	NBR	E321K15	2995	481865	8	9	2.0	3427
	11	36	2.16	2500	0.2	10	10	-10	120	NBR	E321K15	4270	486265	14	14	2.0	3427
	11	36	2.16	2500	0.2	10	3	-10	100	NBR	E321K1514	2995	481865	8	9	2.0	3427
	11	36	2.16	2500	0.2	10	4	-10	120	NBR	E321K1514	-	483371	8	8	2.0	3427
	11	36	2.16	2500	0.2	10	3	-10	100	NBR	E321K25	2995	481865	8	9	2.0	3427
	11	36	2.16	2500	0.2	4	4	-10	120	NBR	E321K25	-	492070	9	8	2.0	3427
	12	50	3	3400	0.3	10	10	-10	100	NBR	321K35	8993	481180	4	5	1.1	7093
	12	50	3	3400	0.3	10	7	-10	75	NBR	321K35	8993	488980	2	2.5	1.1	7093
	12	50	3	3400	0.3	12	12	-10	100	FKM	321K4506	2995	481865	8	9	2.1/3.0	7094
	12	50	3	3400	0.3	12	12	-10	120	FKM	321K4506	4270	481000	8	8	2.1/3.0	7094
	12	50	3	3400	0.3	12	12	-10	100	FKM	321K4556 <sub>1</sub>	2995	481865	8	9	2.1/3.0	7094
	12	50	3	3400	0.3	12	12	-10	120	FKM	321K4556 <sub>1</sub>	4270	481000	8	8	2.1/3.0	7094

#### Notes:

1. With manual override

## 2 WAY VALVES



For this page	Port size	Orifice (mm)	Kv (l/min)	MOPD (bar)	Fluid Temp (°C)	Amb Temp (°C)
From	1/2"	11	36	3	-10	-10
To	1/2"	12	50	12	120	50

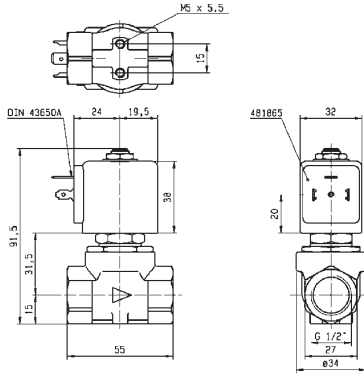

Drawing 3427

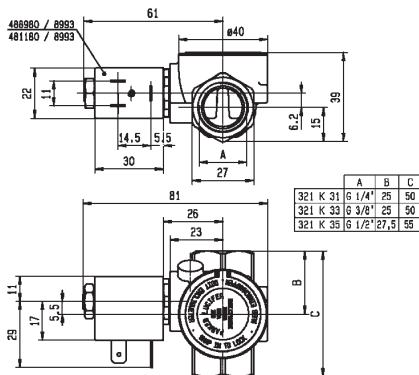

Drawing 7093

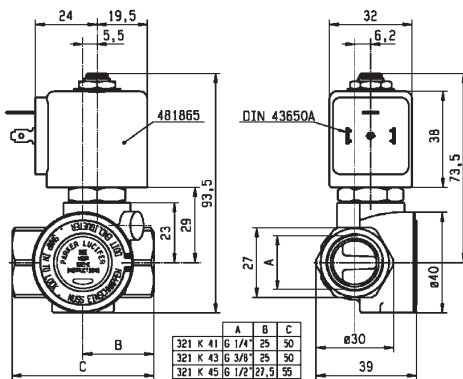

Drawing 7094

## 2 WAY VALVES

# 2/2

## VALVES FOR WATER AND NEUTRAL LIQUIDS

### PILOT OPERATED

### BRASS

### PIPE MOUNTING

### NORMALLY CLOSED

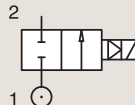

Port size	Orifice Ø	Flow factors			Operating Pressure Differential			Fluid Temp.		Seat Seal	Parker LUCIFER® Valves			Power		Coil Group	Dwg. No.
		Kv l/min	KV m³/h	Qn l/min	Min bar	AC bar	DC bar	Min °C	Max °C		Valve Ref.	Housing Ref.	Coil Ref.	AC W	DC W		
3/4"	18	100	6	9400	0.3	10	10	-10	100	NBR	321K36	8993	481180	4	5	1.1	7097
	18	100	6	9400	0.3	10	7	-10	75	NBR	321K36	8993	488980	2	2.5	1.1	7097
	18	100	6	9400	0.3	12	12	-10	100	FKM	321K4606	2995	481865	8	9	2.1/3.0	7099
	18	100	6	9400	0.3	12	12	-10	120	FKM	321K4606	4270	481000	8	8	2.1/3.0	7099
	18	100	6	9400	0.3	12	12	-10	100	FKM	321K4656 <sub>1</sub>	2995	481865	8	9	2.1/3.0	7099
	18	100	6	9400	0.3	12	12	-10	120	FKM	321K4656 <sub>1</sub>	4270	481000	8	8	2.1/3.0	7099
	20	135	8.1	9500	0.3	16	16	-10	100	NBR	E321G36	2995	481865	8	9	2.0	3442
	20	135	8.1	9500	0.3	16	16	-10	100	NBR	E321G36	4270	481000	8	8	2.0	3442

#### Notes:

1. With manual override

## 2 WAY VALVES



For this page	Port size	Orifice (mm)	Kv (l/min)	MOPD (bar)	Fluid Temp (°C)	Amb Temp (°C)
From	3/4"	18	100	7	-10	-10
To	3/4"	20	135	16	120	50

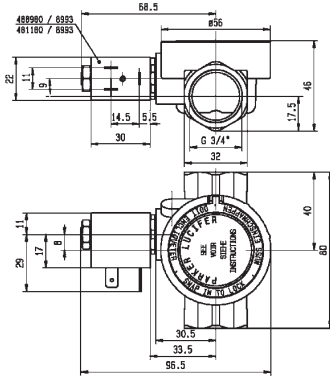

Drawing 7097

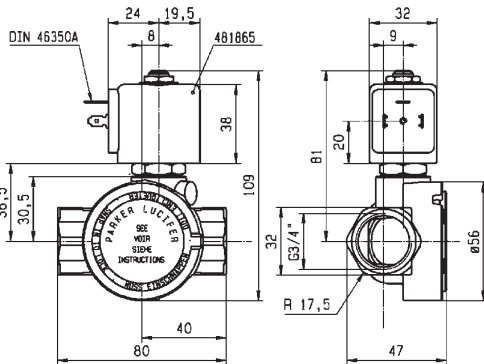

Drawing 7099

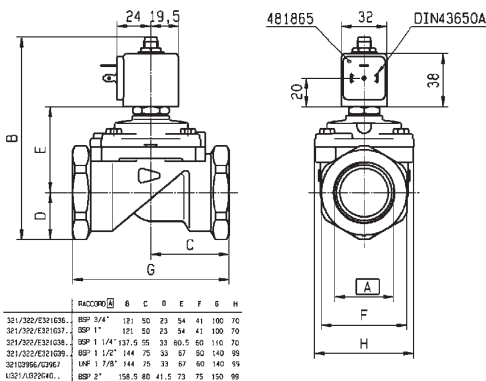

Drawing 3442

## 2 WAY VALVES

# 2/2

## VALVES FOR WATER AND NEUTRAL LIQUIDS

### PILOT OPERATED

### BRASS

### PIPE MOUNTING

### NORMALLY CLOSED

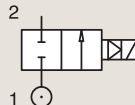

Port size	Orifice Ø	Flow factors			Operating Pressure Differential			Fluid Temp.		Seat Seal	Parker LUCIFER® Valves			Power		Coil Group	Dwg. No.
		Kv l/min	KV m³/h	Qn l/min	Min bar	Max(MOPD) AC bar	DC bar	Min °C	Max °C		Valve Ref.	Housing Ref.	Coil Ref.	AC W	DC W		
1"	18	110	6.6	10150	0.3	10	10	-10	100	NBR	321K37	8993	481180	4	5	1.1	7098
	18	110	6.6	10150	0.3	10	7	-10	75	NBR	321K37	8993	488980	2	2.5	1.1	7098
	18	110	6.6	10150	0.3	12	12	-10	100	FKM	321K4706	2995	481865	8	9	2.1/3.0	7100
	18	110	6.6	10150	0.3	12	12	-10	120	FKM	321K4706	4270	481000	8	8	2.1/3.0	7100
	18	110	6.6	10150	0.3	12	12	-10	100	FKM	321K4756 <sub>2</sub>	2995	481865	8	9	2.1/3.0	7100
	18	110	6.6	10150	0.3	12	12	-10	120	FKM	321K4756 <sub>2</sub>	4270	481000	8	8	2.1/3.0	7100
	25	180	10.8	14000	0.3	16	16	-10	100	NBR	E321G37	2995	481865	8	9	2.0	3442
	25	180	10.8	14000	0.3	16	16	-10	100	NBR	E321G37	4270	481000	8	8	2.0	3442
	28	270	16.2	18000	0.3	16	16	-10	100	NBR	E321G38	2995	481865	8	9	2.0	3442
1 1/2"	40	420	25.2	31500	0.3	16	7	-10	100	NBR	E321G39 <sub>1</sub>	2995	481865	8	9	2.0	3442
2"	40	420	25.2	31500	0.3	16	8.5	-10	100	NBR	E321G39 <sub>1</sub>	4270	481000	8	8	2.0	3442
2"	40	540	32.4	40000	0.3	16	7	-10	100	NBR	E321G40 <sub>1</sub>	2995	481865	8	9	2.0	3442
	40	540	32.4	40000	0.3	16	8.5	-10	100	NBR	E321G40 <sub>1</sub>	4270	481000	8	8	2.0	3442

#### Notes:

1. Pilot seat disc in synthetic Ruby
2. With manual override



## 2 WAY VALVES



For this page	Port size	Orifice (mm)	Kv (l/min)	MOPD (bar)	Fluid Temp (°C)	Amb Temp (°C)
From	1"	18	110	7	-10	-10
To	2"	40	540	16	120	50

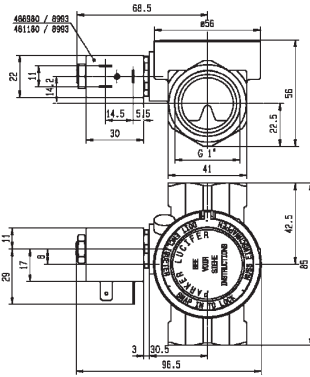

Drawing 7098

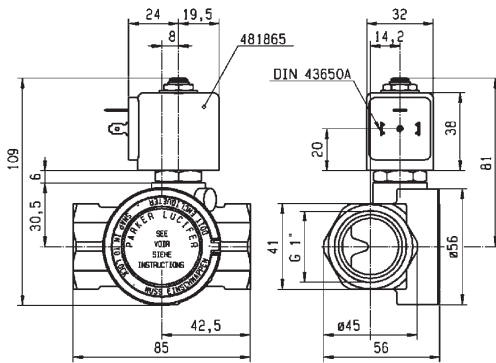

Drawing 7100

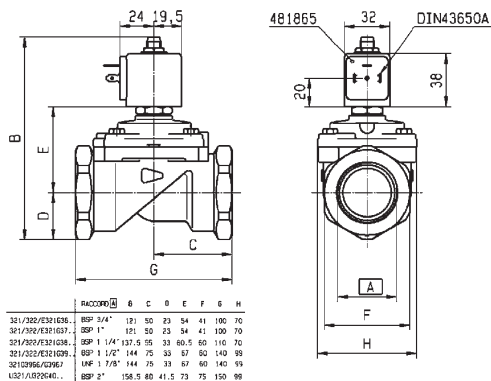

Drawing 3442



## 2 WAY VALVES

# 2/2

## VALVES FOR WATER AND NEUTRAL LIQUIDS

### PILOT OPERATED

BRASS

PIPE MOUNTING

NORMALLY OPEN

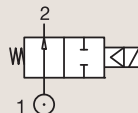

Port size	Orifice Ø	Flow factors			Operating Pressure Differential			Fluid Temp.		Seat Seal	Parker Valves			Power		Coil Group	Dwg. No.
		Kv	KV	Qn	Min	Max	DC	Min	Max		Valve Order Number	Valve Type	Coil Type	AC W	DC W		
BSP	mm	l/min	m³/h	m³/h	bar	AC bar	DC bar	°C	°C								
3/8"	13	50	3	-	0.1	10	10	-10	140	EPDM	444600W	7322BIH00	481865	8	9	2.0	060
	13	50	3	-	0.1	20	20	-10	90	NBR	443805W	7322BIN00	481865	8	9	2.0	060
	13	50	3	-	0.1	20	20	-10	140	FKM	444499W	7322BIV00	481865	8	9	2.0	060
1/2"	13	50	3	-	0.1	10	10	-10	140	EPDM	444601W	7322BAH00	481865	8	9	2.0	060
	13	50	3	-	0.1	20	20	-10	90	NBR	443806W	7322BAN00	481865	8	9	2.0	060
	13	50	3	-	0.1	20	20	-10	140	FKM	444500W	7322BAV00	481865	8	9	2.0	060
3/4"	20	140	8.4	-	0.1	10	10	-10	140	EPDM	444602W	7322BCH00	481865	8	9	2.0	061
	20	140	8.4	-	0.1	20	20	-10	90	NBR	443807W	7322BCN00	481865	8	9	2.0	061
	20	140	8.4	-	0.1	20	20	-10	140	FKM	444501W	7322BCV00	481865	8	9	2.0	061
1"	25	160	9.6	-	0.1	10	10	-10	140	EPDM	444603W	7322BDH00	481865	8	9	2.0	061
	25	160	9.6	-	0.1	20	20	-10	90	NBR	443808W	7322BDN00	481865	8	9	2.0	061
	25	160	9.6	-	0.1	20	20	-10	140	FKM	444502W	7322BDV00	481865	8	9	2.0	061
1 1/4"	35	420	25.2	-	0.1	10	10	-10	140	EPDM	444576W	7322BEH00	481865	8	9	2.0	062
	35	420	25.2	-	0.1	10	10	-10	90	NBR	443809W	7322BEN00	481865	8	9	2.0	062
1 1/2"	40	500	30	-	0.1	10	10	-10	140	EPDM	444604W	7322BFH00	481865	8	9	2.0	062
	40	500	30	-	0.1	10	10	-10	90	NBR	443810W	7322BFN00	481865	8	9	2.0	062
2"	50	620	37.2	-	0.1	10	10	-10	140	EPDM	444605W	7322BGH00	481865	8	9	2.0	062
	50	620	37.2	-	0.1	10	10	-10	90	NBR	443811W	7322BGN00	481865	8	9	2.0	062
2 1/2"	65	1100	66	-	0.2	10	10	-10	90	NBR	444513W	7322BLN06	481865	8	9	2.0	063
3"	75	1334	80	-	0.2	10	10	-10	90	NBR	444503W	7322BMN06	481865	8	9	2.0	063

G	A		B		C	
	mm	inch	mm	inch	mm	inch
1-1/4"	143	5.70	144.5	5.68	102	4.01
1-1/2"	143	5.70	134	5.28	102	4.01
2"	173	6.81	148	5.83	118	4.65

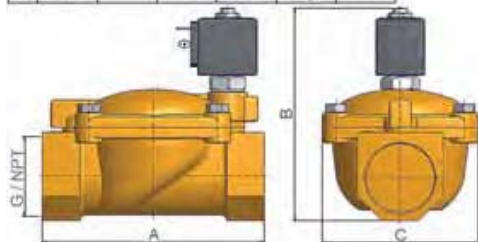

Drawing 062



## 2 WAY VALVES



For this page	Port size	Orifice (mm)	Kv (l/min)	MOPD (bar)	Fluid Temp (°C)	Amb Temp (°C)
From	3/8"	13	50	10	-10	-10
To	3"	75	1334	20	140	50

G	A		B		C	
	mm	inch	mm	inch	mm	inch
NPT						
3/8"	89	2.71	110	4.33	40	1.57
1/2"	72	2.83	122	4.81	40	1.57

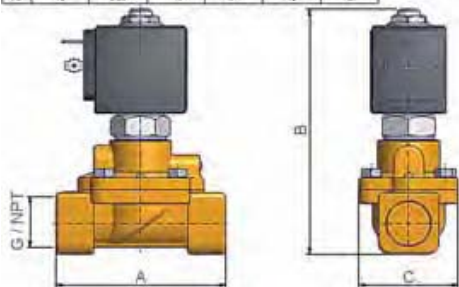

Drawing 060

G	A		B		C	
	mm	inch	mm	inch	mm	inch
NPT						
3/4"	100	3.93	117.5	4.62	65	2.55
1"	104	4.09	123	4.84	65	2.55

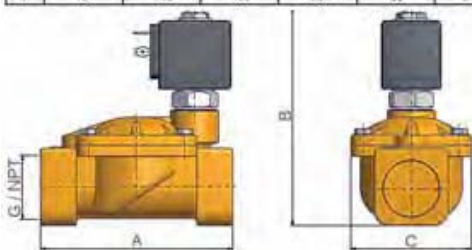

Drawing 061

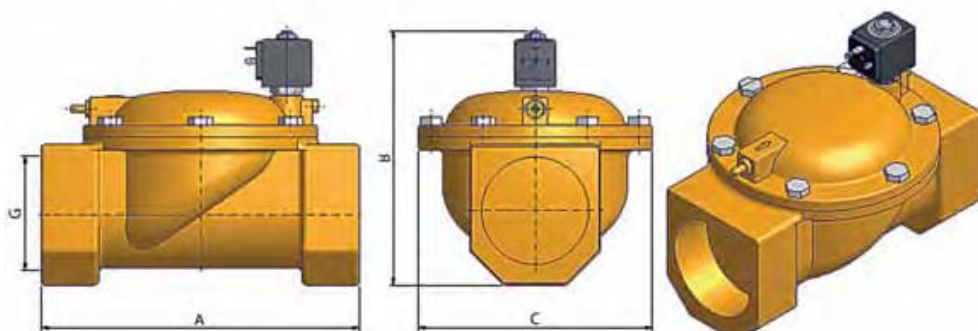

Drawing 063

## 2 WAY VALVES

# 2/2

## VALVES FOR WATER AND NEUTRAL LIQUIDS PILOT OPERATED

### BRASS PIPE MOUNTING

#### NORMALLY OPEN

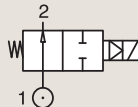

Port size	Orifice Ø	Flow factors			Operating Pressure Differential			Fluid Temp.		Seat Seal	Parker LUCIFER® Valves			Power		Coil Group	Dwg. No.
		Kv l/min	KV m³/h	Qn l/min	Min bar	Max(MOPD) AC bar	DC bar	Min °C	Max °C		Valve Ref.	Housing Ref.	Coil Ref.	AC W	DC W		
1/4"	12	32	1.92	2150	0.3	12	12	-10	100	FKM	322K4106	2995	481865	8	9	2.1	7094
	12	32	1.92	2150	0.3	12	12	-10	120	FKM	322K4106	4270	481000	8	8	2.1	7094
3/8"	12	45	2.7	3050	0.3	12	12	-10	100	FKM	322K4306	2995	481865	8	9	2.1	7094
	12	45	2.7	3050	0.3	12	12	-10	120	FKM	322K4306	4270	481000	8	8	2.1	7094
1/2"	12	50	3	3400	0.3	12	12	-10	100	FKM	322K4506	2995	481865	8	9	2.1	7094
	12	50	3	3400	0.3	12	12	-10	120	FKM	322K4506	4270	481000	8	8	2.1	7094
3/4"	15	60	3.6	3890	0.3	15	15	-10	100	NBR	322G75	2995	481865	8	9	2.1	3522
	15	60	3.6	3890	0.3	15	15	-10	100	NBR	322G75	4270	481000	8	8	2.1	3522
	18	100	6	9400	0.3	12	12	-10	100	FKM	322K4606	2995	481865	8	9	2.1	7099
	18	100	6	9400	0.3	12	12	-10	120	FKM	322K4606	4270	481000	8	8	2.1	7099
3/4"	20	135	8.1	9500	0.3	16	16	-10	100	NBR	322G36	2995	481865	8	9	2.1	3442
	20	135	8.1	9500	0.3	16	16	-10	100	NBR	322G36	4270	481000	8	8	2.1	3442

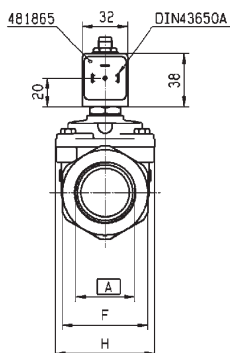
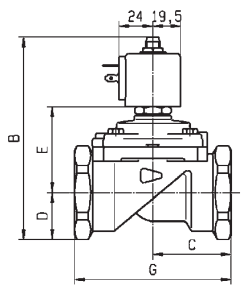

Part No.	Port Size	Orifice	Qn	Qn	Qn	Qn	Qn	Qn	Qn	Qn	Qn	Qn	Qn	Qn	Qn	Qn	Qn
321/322/E321036	BSP 1/4"	12	32	1.92	2150	0.3	12	12	-10	100	FKM	322K4106	2995	481865	8	9	2.1
321/322/E321037	BSP 1"	12	32	1.92	2150	0.3	12	12	-10	120	FKM	322K4106	4270	481000	8	8	2.1
321/322/E321038	BSP 1/4"	12	45	2.7	3050	0.3	12	12	-10	100	FKM	322K4306	2995	481865	8	9	2.1
321/322/E321039	BSP 1/2"	12	50	3	3400	0.3	12	12	-10	100	FKM	322K4506	2995	481865	8	9	2.1
321/322/E321040	BSP 1/2"	12	50	3	3400	0.3	12	12	-10	120	FKM	322K4506	4270	481000	8	8	2.1
321/322/E321041	BSP 1/2"	15	60	3.6	3890	0.3	15	15	-10	100	NBR	322G75	2995	481865	8	9	2.1
321/322/E321042	BSP 1/2"	15	60	3.6	3890	0.3	15	15	-10	100	NBR	322G75	4270	481000	8	8	2.1
321/322/E321043	BSP 3/4"	18	100	6	9400	0.3	12	12	-10	100	FKM	322K4606	2995	481865	8	9	2.1
321/322/E321044	BSP 3/4"	18	100	6	9400	0.3	12	12	-10	120	FKM	322K4606	4270	481000	8	8	2.1
321/322/E321045	BSP 3/4"	20	135	8.1	9500	0.3	16	16	-10	100	NBR	322G36	2995	481865	8	9	2.1
321/322/E321046	BSP 3/4"	20	135	8.1	9500	0.3	16	16	-10	100	NBR	322G36	4270	481000	8	8	2.1

Drawing 3442



## 2 WAY VALVES



For this page	Port size	Orifice (mm)	Kv (l/min)	MOPD (bar)	Fluid Temp (°C)	Amb Temp (°C)
From	1/4"	12	32	12	-10	-10
To	3/4"	20	135	16	120	50

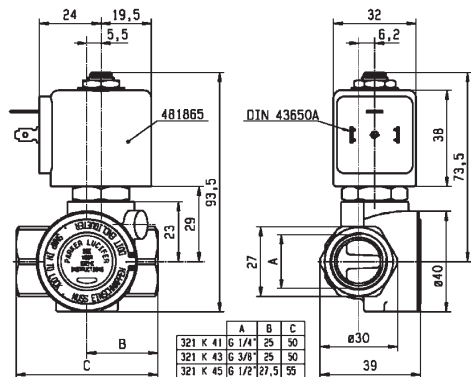

Drawing 7094

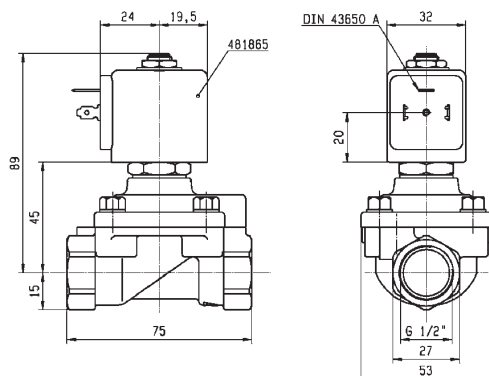

Drawing 3522

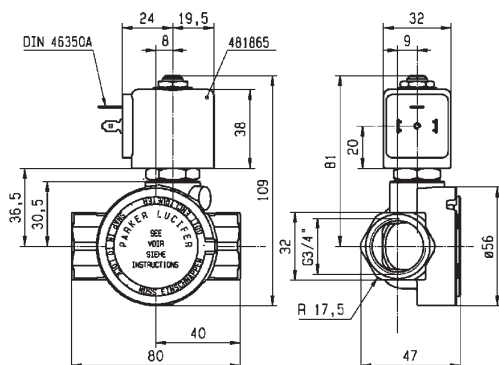

Drawing 7099

## 2 WAY VALVES

# 2/2

## VALVES FOR WATER AND NEUTRAL LIQUIDS PILOT OPERATED

### BRASS

#### PIPE MOUNTING

#### NORMALLY OPEN

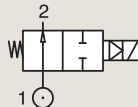

Port size	Orifice Ø	Flow factors			Operating Pressure Differential			Fluid Temp.		Seat Seal	Parker LUCIFER® Valves			Power		Coil Group	Dwg. No.
					Min	Max(MOPD)		Min	Max		Valve Ref.	Housing Ref.	Coil Ref.	AC W	DC W		
						AC bar	DC bar										
1"	18	110	6.6	10150	0.3	12	12	-10	100	FKM	322K4706	2995	481865	8	9	2.0	7100
	18	110	6.6	10150	0.3	12	12	-10	120	FKM	322K4706	4270	481000	8	8	2.0	7100
	25	180	10.8	14000	0.3	16	16	-10	100	NBR	322G37	2995	481865	8	9	2.1	3442
	25	180	10.8	14000	0.3	16	16	-10	100	NBR	322G37	4270	481000	8	8	2.1	3442
1 1/2"	40	420	25.2	31500	0.3	12	12	-10	100	NBR	322G39	2995	481865	8	9	2.1	3442
	40	420	25.2	31500	0.3	12	12	-10	100	NBR	322G39	4270	481000	8	8	2.1	3442

### BRASS

#### SUB-BASE MOUNTING

#### NORMALLY CLOSED

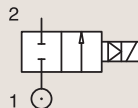

Port size	Orifice Ø	Flow factors			Operating Pressure Differential			Fluid Temp.		Seat Seal	Parker LUCIFER® Valves			Power		Coil Group	Dwg. No.
					Min	Max(MOPD)		Min	Max		Valve Ref.	Housing Ref.	Coil Ref.	AC W	DC W		
						AC bar	DC bar										
SB	14	45	2.7	2100	0.3	40	25	-10	100	NBR	E321F32 <sub>1</sub>	2995	481865	8	9	2.0	3520
	14	45	2.7	2100	0.3	40	30	-10	100	NBR	E321F32 <sub>1</sub>	4270	481000	8	8	2.0	3520
	14	45	2.7	2100	0.3	40	40	-10	100	NBR	E321F32 <sub>1</sub>	4270	486265	14	14	2.0	3520

#### Notes:

1. Pilot seat disc in synthetic Ruby



## 2 WAY VALVES



For this page	Port size	Orifice (mm)	Kv (l/min)	MOPD (bar)	Fluid Temp (°C)	Amb Temp (°C)
From	14 mm	14	45	12	-10	-10
To	1 1/2"	40	420	40	120	50

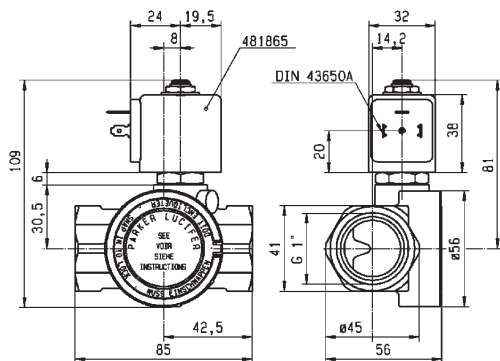

Drawing 7100

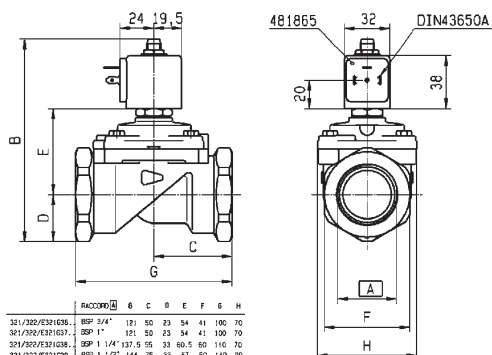

RACCORD	B	C	D	E	F	G	H	
311/322/E31636..	BSP 3/4"	121	50	23	54	41	100	70
311/332/E321637..	BSP 1"	121	50	23	54	41	100	70
311/332/E321638..	BSP 1 1/4"	137.5	55	33	60.5	60	116	70
321/322/E321629..	BSP 1 1/2"	144	75	33	67	60	140	95
321/322/E321630..	LAF 1 7/8"	144	75	33	67	60	140	95
U321/322/E321640..	BSP 2"	158.5	80	41.5	73	75	150	99



Drawing 3442

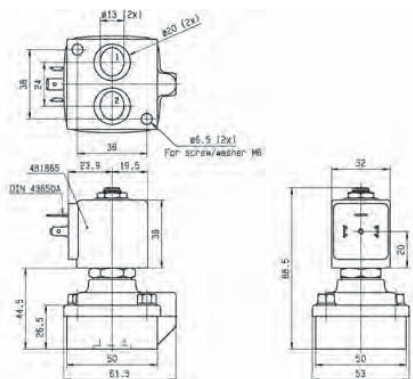

Drawing 3520

## 2 WAY VALVES

## 2 WAY VALVES

### ANTI WATER HAMMER VALVES



Water

# 2/2

Actuation	Body	Function	Port Size	Orifice (mm)	Flow Factor Kv(l/min)	MOPD (bar)	Max Fluid Temp. (°C)	Page Parker Valves	Page Parker LUCIFER® Valves
Magnalift	Brass/Pipe mounting	Normally Closed	1"	15 to 25	170	10	140	-	114
Pilot Operated	Brass/Pipe mounting	Normally Closed	1/4"	12	32	12	120	-	118
			3/8"	12	45	12	120	-	118
			1/2"	12	50	12	120	-	118
			3/4"	18 to 20	135	16	120	-	118
			1"	18 to 25	180	16	120	116	120
			1 1/4"	25 to 28	280	16	100	116	120
			1 1/2"	35 to 40	500	16	100	116	120
			2"	40 to 50	620	16	100	116	120
			2 1/2"	65	1100	10	90	116	-
			3"	75	1334	10	90	116	-
		Normally Open	3/4"	20	135	16	100	-	122
			1"	25	180	16	100	-	122
			1 1/4"	28	270	16	100	-	122
			1 1/2"	40	425	12	100	-	122
			2"	40	540	12	100	-	122

## 2 WAY VALVES

# 2/2

## ANTI WATER HAMMER VALVES MAGNALIFT



Commercial Equipment

### BRASS PIPE MOUNTING

#### NORMALLY CLOSED

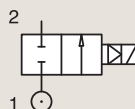

Port size	Orifice Ø	Flow factors			Operating Pressure Differential			Fluid Temp.		Seat Seal	Parker LUCIFER® Valves			Power		Coil Group	Dwg. No.
		Kv l/min	KV m³/h	Qn l/min	Min bar	Max(MOPD) AC bar	DC bar	Min °C	Max °C		Valve Ref.	Housing Ref.	Coil Ref.	AC W	DC W		
1"	15	80	4.8	6000	0	-	10	-10	100	NBR	221G1731 <sup>12</sup>	2995	481865	-	9	2.1	3445
	15	80	4.8	6000	0	10	10	-10	120	NBR	221G1731 <sup>12</sup>	-	492070	9	8	2.1	3445
	15	80	4.8	6000	0	10	10	-10	120	NBR	221G1731 <sup>12</sup>	-	492190	11	9	2.1	3445
	25	160	9.6	-	0	10	-	0	100	EPDM	221G2103	2995	481865	8	-	2.0	3448
	25	160	9.6	-	0	10	-	0	120	EPDM	221G2103	4270	481000	8	-	2.0	3448
	25	160	9.6	-	0	10	10	0	120	EPDM	221G2103	4270	486265	14	14	2.0	3448
	25	160	9.6	-	0	4	4	0	140	EPDM	221G2103	2995	492425	14	14	2.0	3448
	25	170	10.2	14000	0	-	10	-10	100	NBR	221G2131 <sup>12</sup>	2995	481865	-	9	2.1	3448
	25	170	10.2	14000	0	10	10	-25	40	NBR	221G2131 <sup>12</sup>	-	492070	9	8	2.1	3448
	25	170	10.2	14000	0	10	10	-25	40	NBR	221G2131 <sup>12</sup>	-	492190	11	9	2.1	3448

#### Notes:

- Valves with model number ending in 30 or 31 are only compatible with explosion proof electrical parts shown, or with group 2.1 coils only in DC voltage.
- With 4 position selector for controlled closure rate

## 2 WAY VALVES



For this page	Port size	Orifice (mm)	Kv (l/min)	MOPD (bar)	Fluid Temp (°C)	Amb Temp (°C)
From	1"	15	80	4	-25	-10
To	1"	25	170	10	140	50

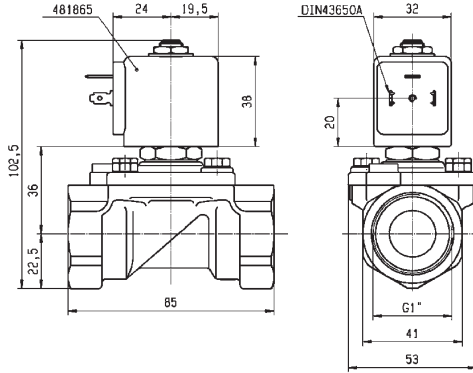

Drawing 3445

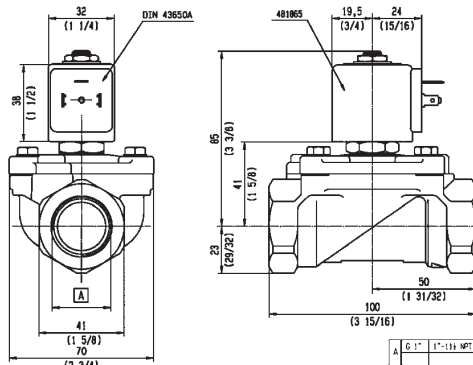

Drawing 3448

## 2 WAY VALVES

# 2/2

## ANTI WATER HAMMER VALVES

### PILOT OPERATED



Commercial Equipment



Industrial Equipment



Medical / Instrumentation

### BRASS PIPE MOUNTING

#### NORMALLY CLOSED

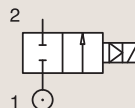

Port size	Orifice Ø	Flow factors			Operating Pressure Differential			Fluid Temp.		Seat Seal	Parker Valves			Power		Coil Group	Dwg. No.
		Kv	KV	Qn	Min	Max(MOPD)	DC	Min	Max		Valve Order Number	Valve Type	Coil Type	AC W	DC W		
BSP	mm	l/min	m <sup>3</sup> /h	m <sup>3</sup> /h	bar	AC bar	DC bar	°C	°C								
3/4"	20	140	8.4	-	0.1	10	10	-10	90	NBR	443784W <sub>1</sub>	7321BCN02	481865	8	9	2.0	057
1"	25	160	9.6	-	0.1	10	10	-10	90	NBR	443788W <sub>1</sub>	7321BDN02	481865	8	9	2.0	057
1 1/4"	35	420	25.2	-	0.1	5	5	-10	90	NBR	443792W <sub>1</sub>	7321BEN02	481865	8	9	2.0	058
1 1/2"	40	500	30	-	0.1	5	5	-10	90	NBR	443796W <sub>1</sub>	7321BFN02	481865	8	9	2.0	058
2"	50	620	37.2	-	0.1	5	5	-10	90	NBR	443800W <sub>1</sub>	7321BGN02	481865	8	9	2.0	058
2 1/2"	65	1100	66	-	0.2	10	10	-10	90	NBR	443802W <sub>1</sub>	7321BLN02	481865	8	9	2.0	059
3"	75	1334	80	-	0.2	10	10	-10	90	NBR	443803W <sub>1</sub>	7321BMN02	481865	8	9	2.0	059

**Notes:**

1. With manual override

## 2 WAY VALVES



For this page	Port size	Orifice (mm)	Kv (l/min)	MOPD (bar)	Fluid Temp (°C)	Amb Temp (°C)
From	1"	20	140	5	-10	-10
To	3"	75	1334	10	90	50

G	A		B		C	
NPT	mm	inch	mm	inch	mm	inch
3/4"	102	3.99	127	4.99	85	3.33
1"	104	4.09	112.5	4.42	85	3.33

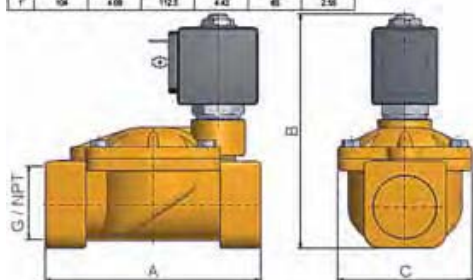

Drawing 057

G	A		B		C	
NPT	mm	inch	mm	inch	mm	inch
1 1/4"	145	5.70	124	4.87	102	4.01
1 1/2"	145	5.70	134	5.27	102	4.01
2"	173	6.81	148	5.82	118	4.64

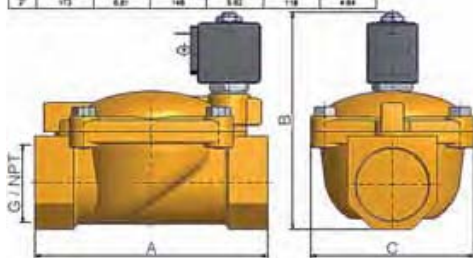

Drawing 058

G	A		B		C	
NPT	mm	inch	mm	inch	mm	inch
3-1/2"	245	—	195	—	184	—
4"	250	—	195	—	184	—

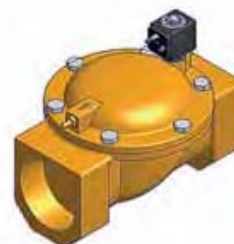
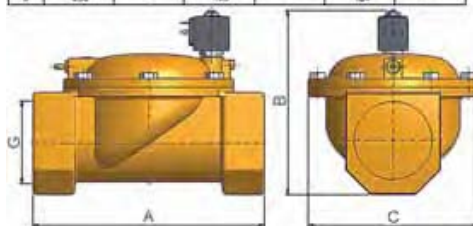

Drawing 059



## 2 WAY VALVES

# 2/2

## ANTI WATER HAMMER VALVES PILOT OPERATED

### BRASS

### PIPE MOUNTING

### NORMALLY CLOSED

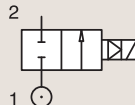

Port size	Orifice Ø	Flow factors			Operating Pressure Differential Max(MOPD)			Fluid Temp.		Seat Seal	Parker LUCIFER® Valves			Power		Coil Group	Dwg. No.
		Kv	KV	Qn	Min	AC	DC	Min	Max		Valve Ref.	Housing Ref.	Coil Ref.	AC W	DC W		
BSP	mm	l/min	m³/h	l/min	bar	bar	bar	°C	°C								
1/4"	12	32	1.92	2150	0.3	12	12	-10	100	FKM	321K4106	2995	481865	8	9	2.1/3.0	7094
	12	32	1.92	2150	0.3	12	12	-10	120	FKM	321K4106	4270	481000	8	8	2.1/3.0	7094
3/8"	12	45	2.7	3050	0.3	12	12	-10	100	FKM	321K4306	2995	481865	8	9	2.1/3.0	7094
	12	45	2.7	3050	0.3	12	12	-10	120	FKM	321K4306	4270	481000	8	8	2.1/3.0	7094
1/2"	12	50	3	3400	0.3	12	12	-10	100	FKM	321K4506	2995	481865	8	9	2.1/3.0	7094
	12	50	3	3400	0.3	12	12	-10	120	FKM	321K4506	4270	481000	8	8	2.1/3.0	7094
	12	50	3	3400	0.3	12	12	-10	100	FKM	321K4556 <sub>1</sub>	2995	481865	8	9	2.1/3.0	7094
	12	50	3	3400	0.3	12	12	-10	120	FKM	321K4556 <sub>1</sub>	4270	481000	8	8	2.1/3.0	7094
3/4"	18	100	6	9400	0.3	12	12	-10	100	FKM	321K4606	2995	481865	8	9	2.1/3.0	7099
	18	100	6	9400	0.3	12	12	-10	120	FKM	321K4606	4270	481000	8	8	2.1/3.0	7099
	18	100	6	9400	0.3	12	12	-10	100	FKM	321K4656 <sub>1</sub>	2995	481865	8	9	2.1/3.0	7099
	18	100	6	9400	0.3	12	12	-10	120	FKM	321K4656 <sub>1</sub>	4270	481000	8	8	2.1/3.0	7099
	20	135	8.1	9500	0	16	16	-10	100	NBR	E321G3610 <sub>2</sub>	2995	481865	8	9	2.0	3442
	20	135	8.1	9500	0	16	16	-10	100	NBR	E321G3610 <sub>2</sub>	4270	481000	8	8	2.0	3442

#### Notes:

1. With manual override

2. With manual override and 4 position selector for controlled closure rate - without manual override and without 4 position selector on request: use same reference removing suffix '10', e.g. E321G36



## 2 WAY VALVES



For this page	Port size	Orifice (mm)	Kv (l/min)	MOPD (bar)	Fluid Temp (°C)	Amb Temp (°C)
From	1/4"	12	32	12	-10	-10
To	3/4"	20	135	16	120	50

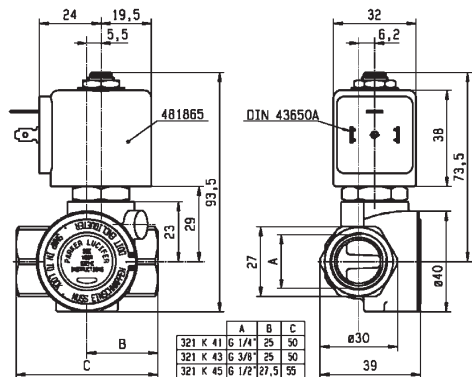

Drawing 7094

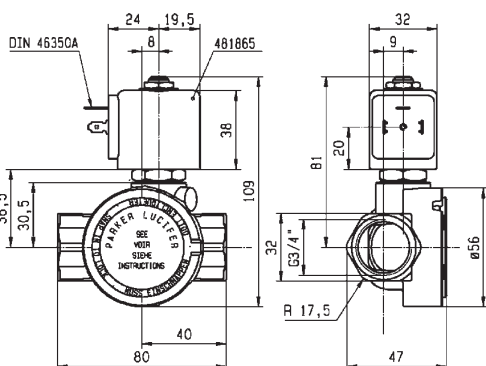

Drawing 7099

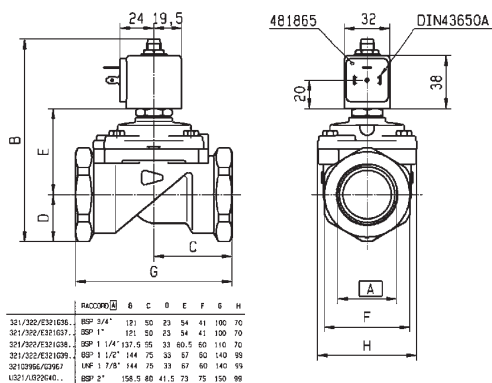

Drawing 3442



## 2 WAY VALVES

# 2/2

## ANTI WATER HAMMER VALVES PILOT OPERATED

### BRASS

### PIPE MOUNTING

### NORMALLY CLOSED

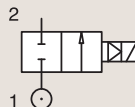

Port size	Orifice Ø	Flow factors			Operating Pressure Differential Max(MOPD)			Fluid Temp.		Seat Seal	Parker LUCIFER® Valves			Power		Coil Group	Dwg. No.
											Valve Ref.	Housing Ref.	Coil Ref.	AC W	DC W		
BSP	mm	Kv l/min	KV m³/h	Qn l/min	bar	AC bar	DC bar	Min °C	Max °C								
1"	18	110	6.6	10150	0.3	12	12	-10	100	FKM	321K4706	2995	481865	8	9	2.1/3.0	7100
	18	110	6.6	10150	0.3	12	12	-10	120	FKM	321K4706	4270	481000	8	8	2.1/3.0	7100
	18	110	6.6	10150	0.3	12	12	-10	100	FKM	321K4756 <sub>1</sub>	2995	481865	8	9	2.1/3.0	7100
	18	110	6.6	10150	0.3	12	12	-10	120	FKM	321K4756 <sub>1</sub>	4270	481000	8	8	2.1/3.0	7100
	25	180	10.8	14000	0.3	16	16	-10	100	NBR	E321G3710 <sub>2</sub>	2995	481865	8	9	2.0	3442
1 1/4"	28	280	16.8	18000	0.3	16	16	-10	100	NBR	E321G3810 <sub>2</sub>	2995	481865	8	9	2.0	3442
	28	280	16.8	18000	0.3	16	16	-10	100	NBR	E321G3810 <sub>2</sub>	4270	481000	8	8	2.0	3442
1 1/2"	40	420	25.2	31500	0.3	16	7	-10	100	NBR	E321G3910 <sub>2</sub>	2995	481865	8	9	2.0	3442
	40	420	25.2	31500	0.3	16	8.5	-10	100	NBR	E321G3910 <sub>2</sub>	4270	481000	8	8	2.0	3442
2"	40	540	32.4	40000	0.3	16	7	-10	100	NBR	E321G4010 <sub>2</sub>	2995	481865	8	9	2.0	3442
	40	540	32.4	40000	0.3	16	8.5	-10	100	NBR	E321G4010 <sub>2</sub>	4270	481000	8	8	2.0	3442

#### Notes:

1. With manual override

2. With manual override and 4 position selector for controlled closure rate - without manual override and without 4 position selector on request: use same reference removing suffix '10', e.g. E321G36



## 2 WAY VALVES



For this page	Port size	Orifice (mm)	Kv (l/min)	MOPD (bar)	Fluid Temp (°C)	Amb Temp (°C)
From	1"	18	110	7	-10	-10
To	2"	40	540	16	120	50

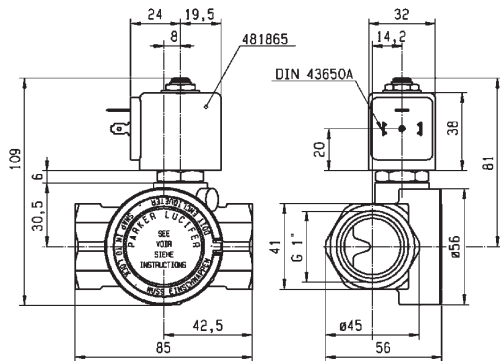

Drawing 7100

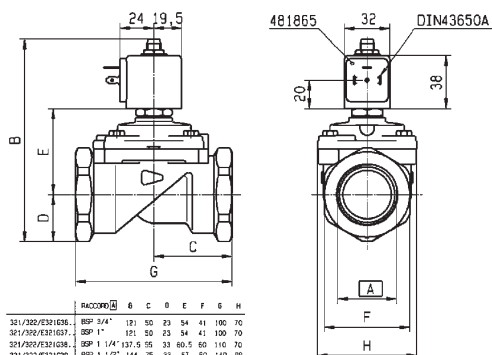

Drawing 3442

RACCORD	B	C	D	E	F	G	H
311/322/E311E36..	BSP 3/4"	121	50	23	54	41	100
311/332/E321G37..	BSP 1"	121	50	23	54	41	100
311/330/E311G38..	BSP 1 1/4"	137.5	55	33	60.5	60	116
321/322/E311G29..	BSP 1 1/2"	144	75	33	67	60	140
32102956/G2967	UNF 1 7/8"	144	75	33	67	60	140
U321/U322E40..	BSP 2"	158.5	80	41.5	73	75	150

## 2 WAY VALVES

# 2/2

## ANTI WATER HAMMER VALVES PILOT OPERATED

BRASS  
PIPE MOUNTING

**NORMALLY OPEN**

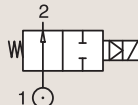

Port size	Orifice Ø	Flow factors			Operating Pressure Differential			Fluid Temp.		Seat Seal	Parker LUCIFER® Valves			Power		Coil Group	Dwg. No.
					Min	Max(MOPD)	DC bar	Min	Max		Valve Ref.	Housing Ref.	Coil Ref.	AC W	DC W		
BSP	mm	Kv l/min	KV m³/h	Qn l/min	bar	AC bar	DC bar	°C	°C								
3/4"	20	135	8.1	9300	0.3	16	16	-10	100	NBR	322G3610 <sub>1</sub>	2995	481865	8	9	2.1	3442
	20	135	8.1	9300	0.3	16	16	-10	100	NBR	322G3610 <sub>1</sub>	4270	481000	8	8	2.1	3442
1"	25	180	10.8	14000	0.3	16	16	-10	100	NBR	322G3710 <sub>1</sub>	2995	481865	8	9	2.1	3442
	25	180	10.8	14000	0.3	16	16	-10	100	NBR	322G3710 <sub>1</sub>	4270	481000	8	8	2.1	3442
1 1/4"	28	270	16.2	18000	0.3	16	16	-10	100	NBR	322G3810 <sub>1</sub>	2995	481865	8	9	2.1	3442
	28	270	16.2	18000	0.3	16	16	-10	100	NBR	322G3810 <sub>1</sub>	4270	481000	8	8	2.1	3442
1 1/2"	40	425	25.5	31000	0.3	12	12	-10	100	NBR	322G3910 <sub>1</sub>	2995	481865	8	9	2.1	3442
	40	425	25.5	31000	0.3	12	12	-10	100	NBR	322G3910 <sub>1</sub>	4270	481000	8	8	2.1	3442
2"	40	540	32.4	40000	0.3	12	12	-10	100	NBR	322G4010 <sub>1</sub>	2995	481865	8	9	2.1	3442
	40	540	32.4	40000	0.3	12	12	-10	100	NBR	322G4010 <sub>1</sub>	4270	481000	8	8	2.1	3442

**Notes:**

1. With 4 position selector for controlled closure rate



## 2 WAY VALVES



For this page	Port size	Orifice (mm)	Kv (l/min)	MOPD (bar)	Fluid Temp (°C)	Amb Temp (°C)
From	3/4"	20	135	12	-10	-10
To	2"	40	540	16	100	50

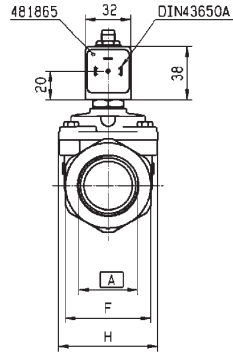
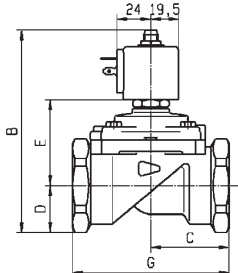

FACTOR	B	C	D	E	F	G	H
311/302/E311G36..	BBP 3/4"	121	50	23	34	41	100
311/302/E311G37..	BBP 1"	121	50	23	34	41	100
311/300/E311G38..	BBP 1 1/4"	137.5	55	33	60.5	60	110
311/302/E311G39..	BBP 1 1/2"	144	75	33	67	60	140
311/296/E311G36..	LF6 1 7/8"	144	75	33	67	60	140
US21/A322640..	BBP 2"	158.5	80	41.5	73	75	150

Drawing 3442

## 2 WAY VALVES

## 2 WAY VALVES

### HOT WATER AND STEAM VALVES



# 2/2

Actuation	Body	Function	Port Size	Orifice (mm)	Flow Factor Kv(l/min)	MOPD (bar)	Max Fluid Temp. (°C)	Page Parker Valves	Page Parker LUCIFER® Valves
Direct Operated	Brass/Pipe mounting	Normally Closed	1/8"	2.5	3.2	30	140	126	-
			1/4"	2.5 to 5	11	30	180	126	128
			3/8"	6	12	5	140	-	128
			1/2"	8.5 to 11	36	4	120	-	128
Magnalift	303 Stainless St./Pipe mounting	Normally Closed	1/4"	1.5 to 5	10	100	180	-	130
	Brass/Pipe mounting	Normally Closed	3/8"	15	65	10	140	-	132
1/2"	15		65	10	140	-	132		
3/4"	15		80	10	140	-	132		
1"	15		80	10	140	-	132		
Pilot Operated	Brass/Pipe mounting	Normally Closed	3/8"	10 to 16	78	16	180	134	-
			1/2"	10 to 16	78	16	180	134	138
			3/4"	18 to 27	193	14	180	136	-
			1"	18 to 27	193	14	180	136	-

## 2 WAY VALVES

# 2/2

## HOT WATER AND STEAM VALVES DIRECT OPERATED



Commercial Equipment



Industrial Equipment



Medical / Instrumentation

### BRASS PIPE MOUNTING

#### NORMALLY CLOSED

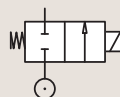

Port size	Orifice Ø	Flow factors			Operating Pressure Differential			Fluid Temp.		Seat Seal	Parker Valves			Power		Coil Group	Dwg. No.
		Kv	KV	Qn	Min	Max(MOPD)	DC	Min	Max		Valve Order Number	Valve Type	Coil Type	AC W	DC W		
BSP	mm	l/min	m <sup>3</sup> /h	m <sup>3</sup> /h	bar	AC bar	DC bar	°C	°C								
1/8"	2.5	3.2	0.20	-	0	30	-	-30	140	Ruby	362496J	PM140IR	ZB09	9	-	20.1/20.2	027
	2.5	3.2	0.20	-	0	-	17	-30	140	Ruby	362496J	PM140IR	ZB12	-	12	20.1/20.2	027
1/4"	2.5	3.2	0.20	-	0	30	-	-30	140	Ruby	362518J <sub>1</sub>	PM140CR	ZB09	9	-	20.1/20.2	026
	2.5	3.2	0.20	-	0	-	17	-30	140	Ruby	362518J <sub>1</sub>	PM140CR	ZB12	-	12	20.1/20.2	026
	2.5	3.2	0.20	-	0	30	-	-30	140	Ruby	362518J <sub>1</sub>	PM140CR	ZH14	14	-	20.1/20.2	026
	2.5	3.2	0.20	-	0	-	17	-30	140	Ruby	362518J <sub>1</sub>	PM140CR	ZH16	-	16	20.1/20.2	026
	3	4.2	0.25	-	0	10	-	-10	140	EPDM	360470 <sub>2</sub>	PM126YH	ZB09	9	-	20.1/20.2	008
	3	4.2	0.25	-	0	-	6	-10	140	EPDM	360470 <sub>2</sub>	PM126YH	ZB12	-	12	20.1/20.2	008
	3	4.2	0.25	-	0	10	-	-10	140	EPDM	360470 <sub>2</sub>	PM126YH	ZH14	14	-	20.1/20.2	008
	3	4.2	0.25	-	0	-	6	-10	140	EPDM	360470 <sub>2</sub>	PM126YH	ZH16	-	16	20.1/20.2	008
	3	4.2	0.25	-	0	10	-	-10	180	PTFE	360475 <sub>2</sub>	PM126YT	ZH14	14	-	20.1/20.2	008
	3	4.2	0.25	-	0	-	10	-10	180	PTFE	360475 <sub>2</sub>	PM126YT	ZH16	-	16	20.1/20.2	008
	3	4	0.24	-	0	30	-	-30	140	Ruby	362524J	PM140DR	ZB09	9	-	20.1/20.2	026
	3	4	0.24	-	0	-	12	-30	140	Ruby	362524J	PM140DR	ZB12	-	12	20.1/20.2	026
	3	4	0.24	-	0	30	-	-30	140	Ruby	362524J	PM140DR	ZH14	14	-	20.1/20.2	026
	3	4	0.24	-	0	-	12	-30	140	Ruby	362524J	PM140DR	ZH16	-	16	20.1/20.2	026
	3	3.3	0.2	-	0	10	-	-10	140	EPDM	364880J <sub>2</sub>	PM158IH	ZH14	14	-	20.2	042
	3	3.3	0.2	-	0	-	4	-10	140	EPDM	364880J <sub>2</sub>	PM158IH	ZH16	-	16	20.2	042
3	3.3	0.2	-	0	10	-	-10	180	PTFE	364884J <sub>2</sub>	PM158IT	ZH14	14	-	20.2	042	
3	3.3	0.2	-	0	-	10	-10	180	PTFE	364884J <sub>2</sub>	PM158IT	ZH16	-	16	20.2	042	

#### Notes:

1. DIN-EN-ISO 23553-1 (2009-10) approved for oil burners
2. Maximum pressure for steam: 4 Bar (140°C)



## 2 WAY VALVES



For this page	Port size	Orifice (mm)	Kv (l/min)	MOPD (bar)	Fluid Temp (°C)	Amb Temp (°C)
From	1/8"	2.5	3.2	4	-30	-10
To	1/4"	3	4.2	30	180	50

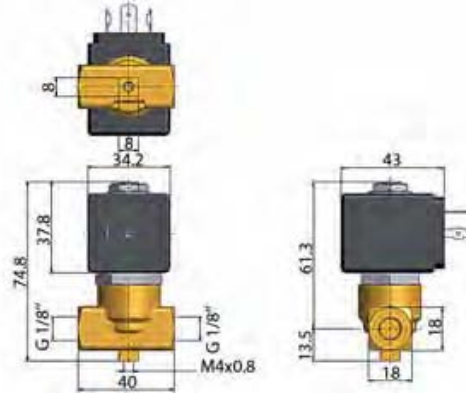

Drawing 027

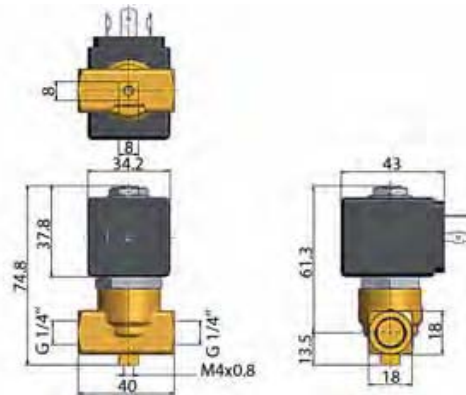

Drawing 026

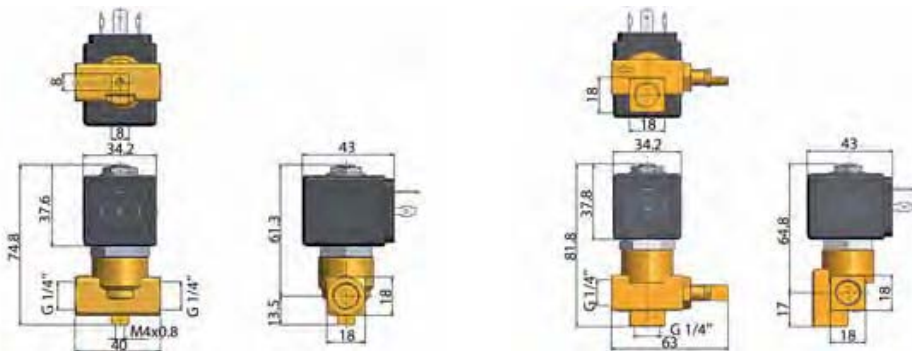

Drawing 008

Drawing 042

**2 WAY VALVES**

# 2/2

## HOT WATER AND STEAM VALVES

### DIRECT OPERATED

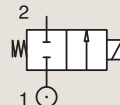
**BRASS**
**PIPE MOUNTING**
**NORMALLY CLOSED**

Port size	Orifice Ø	Flow factors			Operating Pressure Differential			Fluid Temp.		Seat Seal	Parker LUCIFER® Valves			Power		Coil Group	Dwg. No.
					Min	Max(MOPD)	DC bar	Min	Max		Valve Ref.	Housing Ref.	Coil Ref.	AC W	DC W		
					bar	AC bar	DC bar	°C	°C								
1/4"	3	4.5	0.27	-	0	10	7	0	100	EPDM	121K0323	2995	481865	8	9	2.0	3510
	3	4.5	0.27	-	0	10	8.5	0	120	EPDM	121K0323	4270	481000	8	8	2.0	3510
	3	4.5	0.27	-	0	10	10	0	120	EPDM	121K0323	4270	486265	14	14	2.0	3510
	3	4.5	0.27	-	0	10	10	0	120	EPDM	121K0323	2995	492425	14	14	2.0	3510
	5	11	0.66	750	0	7	2	0	100	EPDM	121K0103	2995	481865	8	9	2.0	3510
	5	11	0.66	750	0	7	2.8	0	120	EPDM	121K0103	4270	481000	8	8	2.0	3510
	5	11	0.66	750	0	7	5	0	120	EPDM	121K0103	4270	486265	14	14	2.0	3510
	5	11	0.66	750	0	4	3.5	0	120	EPDM	121K0103	2995	492425	14	14	2.0	3510
3/8"	5	11	0.66	750	0	7	2	0	100	EPDM	121K0113	2995	481865	8	9	2.0	3510
	6	12	0.72	1100	0	5	1.1	0	100	EPDM	121K3303	2995	481865	8	9	2.0	3551
	6	12	0.72	1100	0	5	1.5	0	120	EPDM	121K3303	4270	481000	8	8	2.0	3551
	6	12	0.72	1100	0	4	4	0	120	EPDM	121K3303	4270	486265	14	14	2.0	3551
1/2"	6	12	0.72	1100	0	4	4	0	140	EPDM	121K3303	2995	492425	14	14	2.0	3551
	8.5	25	1.5	-	0	2.2	0.5	0	120	EPDM	E121K4603	4270	481000	8	8	2.0	3427
	8.5	25	1.5	-	0	4	1.2	0	120	EPDM	E121K4603	4270	486265	14	14	2.0	3427
	8.5	25	1.5	-	0	4	1	0	120	EPDM	E121K4603	2995	492425	14	14	2.0	3427
	11	36	2.16	-	0	1.2	0.35	0	120	EPDM	E121K4503	4270	481000	8	8	2.0	3427
11	36	2.16	-	0	2.5	0.7	0	120	EPDM	E121K4503	4270	486265	14	14	2.0	3427	
11	36	2.16	-	0	2.5	0.5	0	120	EPDM	E121K4503	2995	492425	14	14	2.0	3427	



## 2 WAY VALVES



For this page	Port size	Orifice (mm)	Kv (l/min)	MOPD (bar)	Fluid Temp (°C)	Amb Temp (°C)
From	1/4"	3	4.5	0.4	0	-10
To	1/2"	11	36	10	140	50

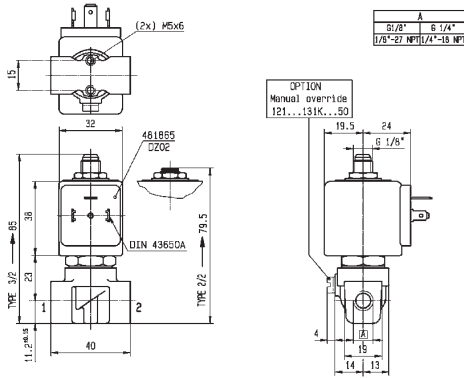

Drawing 3510

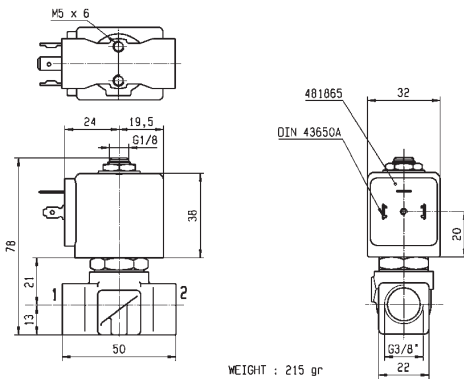

Drawing 3551

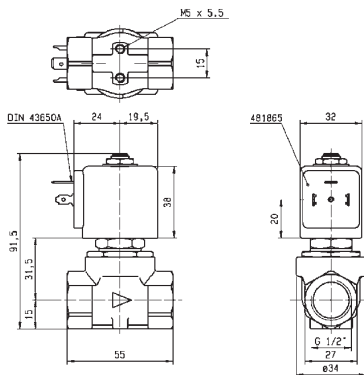

Drawing 3427

## 2 WAY VALVES

# 2/2

## HOT WATER AND STEAM VALVES

### DIRECT OPERATED

### 303 STAINLESS ST.

### PIPE MOUNTING

### NORMALLY CLOSED

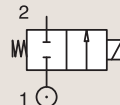

Port size	Orifice Ø	Flow factors			Operating Pressure Differential			Fluid Temp.		Seat Seal	Parker LUCIFER® Valves			Power		Coil Group	Dwg. No.
											Valve Ref.	Housing Ref.	Coil Ref.	AC W	DC W		
1/4"	1.5	1.5	0.09	80	0	60	25	0	100	Ruby	121V5463	2995	481865	8	9	2.0	8116
	1.5	1.5	0.09	80	0	75	30	0	130	Ruby	121V5463	4270	481000	8	8	2.0	8116
	1.5	1.5	0.09	80	0	100	55	0	140	Ruby	121V5463	4270	486265	14	14	2.0	8116
	2.5	3.5	0.21	220	0	28	10	0	100	Ruby	121V5763	2995	481865	8	9	2.0	8116
	2.5	3.5	0.21	220	0	34	12	0	130	Ruby	121V5763	4270	481000	8	8	2.0	8116
	2.5	3.5	0.21	220	0	50	22	0	140	Ruby	121V5763	4270	486265	14	14	2.0	8116
	3	4.5	0.27	315	0	20	7	0	100	Ruby	121V5363	2995	481865	8	9	2.0	8116
	3	4.5	0.27	315	0	25	8.5	0	130	Ruby	121V5363	4270	481000	8	8	2.0	8116
	3	4.5	0.27	315	0	36	15	0	140	Ruby	121V5363	4270	486265	14	14	2.0	8116
	4	7	0.42	450	0	12	4	0	100	Ruby	121V5263	2995	481865	8	9	2.0	8116
	4	7	0.42	450	0	15	5	0	130	Ruby	121V5263	4270	481000	8	8	2.0	8116
	4	7	0.42	450	0	22	10	0	180	Ruby	121V5263	4270	486265	14	14	2.0	8116
	5	10	0.6	750	0	8.5	2	0	100	Ruby	121V5163	2995	481865	8	9	2.0	8116
	5	10	0.6	750	0	10	3.5	0	130	Ruby	121V5163	4270	481000	8	8	2.0	8116
	5	10	0.6	750	0	14	6.5	0	140	Ruby	121V5163	4270	486265	14	14	2.0	8116

## 2 WAY VALVES



For this page	Port size	Orifice (mm)	Kv (l/min)	MOPD (bar)	Fluid Temp (°C)	Amb Temp (°C)
From	1/4"	1.5	1.5	2	0	-10
To	1/4"	5	10	100	180	50

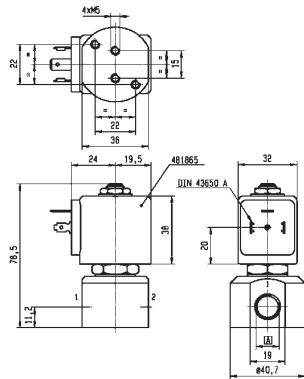

A G 1/8"  
G 1/4"



Drawing 8116

## 2 WAY VALVES

# 2/2

## HOT WATER AND STEAM VALVES

### MAGNALIFT



Commercial Equipment



Industrial Equipment



Medical / Instrumentation

### BRASS PIPE MOUNTING

#### NORMALLY CLOSED

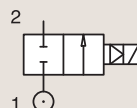

Port size	Orifice Ø	Flow factors			Operating Pressure Differential			Fluid Temp.		Seat Seal	Parker LUCIFER® Valves			Power		Coil Group	Dwg. No.
		Kv l/min	KV m³/h	Qn l/min	Min bar	Max(MOPD) AC bar	DC bar	Min °C	Max °C		Valve Ref.	Housing Ref.	Coil Ref.	AC W	DC W		
3/8"	15	65	3.9	-	0	10	-	0	100	EPDM	221G1303	2995	481865	8	-	2.0	3732
	15	65	3.9	-	0	10	-	0	120	EPDM	221G1303	4270	481000	8	-	2.0	3732
	15	65	3.9	-	0	4	4	0	140	EPDM	221G1303	4270	486265	14	14	2.0	3732
	15	65	3.9	4500	0	10	10	-10	100	FKM	221G1330 <sub>1</sub>	2995	481865	8	9	2.1	3732
	15	65	3.9	4500	0	10	10	-10	120	FKM	221G1330 <sub>1</sub>	-	492070	9	8	2.1	3732
	15	65	3.9	4500	0	10	10	-10	120	FKM	221G1330 <sub>1</sub>	-	492190	11	9	2.1	3732
1/2"	15	65	3.9	-	0	10	-	0	100	EPDM	221G1503	2995	481865	8	-	2.0	3732
	15	65	3.9	-	0	10	-	0	120	EPDM	221G1503	4270	481000	8	-	2.0	3732
	15	65	3.9	-	0	10	7	0	140	EPDM	221G1503	4270	486265	14	14	2.0	3732
3/4"	15	80	4.8	-	0	10	-	0	100	EPDM	221G1603	2995	481865	8	-	2.0	3444
	15	80	4.8	-	0	10	-	0	120	EPDM	221G1603	4270	481000	8	-	2.0	3444
	15	80	4.8	-	0	4	4	0	140	EPDM	221G1603	4270	486265	14	14	2.0	3444
1"	15	80	4.8	-	0	10	-	0	100	EPDM	221G1703	2995	481865	8	-	2.0	3445
	15	80	4.8	-	0	10	-	0	120	EPDM	221G1703	4270	481000	8	-	2.0	3445
	15	80	4.8	-	0	10	10	0	140	EPDM	221G1703	4270	486265	14	14	2.0	3445

**Notes:**

1. Valves with model number ending in 30 or 31 are only compatible with explosion proof electrical parts shown, or with group 2.1 coils only in DC voltage.



## 2 WAY VALVES



For this page	Port size	Orifice (mm)	Kv (l/min)	MOPD (bar)	Fluid Temp (°C)	Amb Temp (°C)
From	3/8"	15	65	4	-10	-10
To	1"	15	80	10	140	50

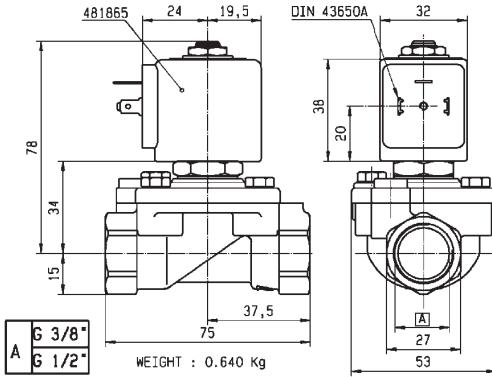

Drawing 3732

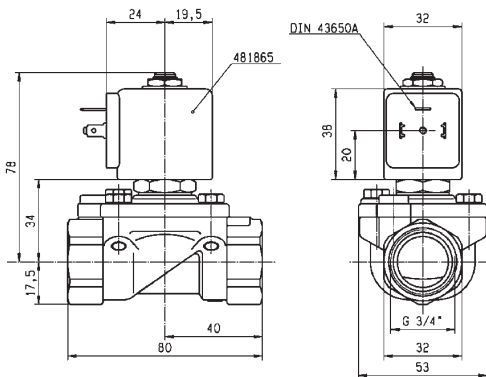

Drawing 3444

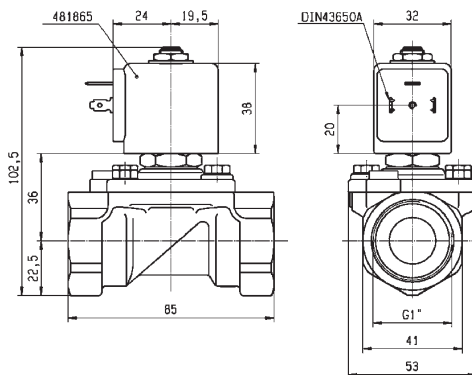

Drawing 3445



## 2 WAY VALVES

# 2/2

## HOT WATER AND STEAM VALVES

### PILOT OPERATED



Commercial Equipment



Industrial Equipment



Medical / Instrumentation

### BRASS PIPE MOUNTING

#### NORMALLY CLOSED

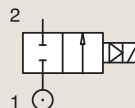

Port size	Orifice Ø	Flow factors			Operating Pressure Differential			Fluid Temp.		Seat Seal	Parker Valves			Power		Coil Group	Dwg. No.
		Kv	KV	Qn	Min	Max(MOPD)	Min	Max	Valve Order Number		Valve Type	Coil Type	AC W	DC W			
BSP	mm	l/min	m <sup>3</sup> /h	m <sup>3</sup> /h	bar	AC bar	DC bar	°C	°C								
3/8"	10	22	1.32	-	0.5	16	-	-30	160	PTFE	364520	PM156.2IR	ZB09	9	-	20.1	041
	16	78	4.7	-	0.5	10	-	-30	180	PTFE	362262	PM135IT	ZH14	14	-	20.2	017
	16	78	4.7	-	0.5	-	10	-30	180	PTFE	362262	PM135IT	ZH16	-	16	20.2	017
1/2"	16	78	4.7	-	0.5	10	-	-30	180	PTFE	362263	PM135AT	ZH14	14	-	20.2	016
	16	78	4.7	-	0.5	-	10	-30	180	PTFE	362263	PM135AT	ZH16	-	16	20.2	016

**Notes:**

1. Maximum pressure for steam: 6.5 Bar (160°C)

## 2 WAY VALVES



For this page	Port size	Orifice (mm)	Kv (l/min)	MOPD (bar)	Fluid Temp (°C)	Amb Temp (°C)
From	3/8"	10	22	10	-30	-10
To	1/2"	16	78	16	180	50

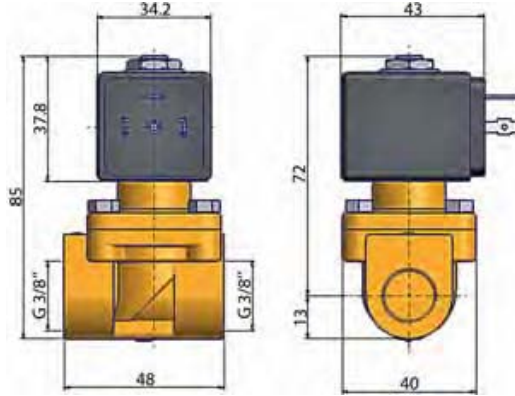

Drawing 041

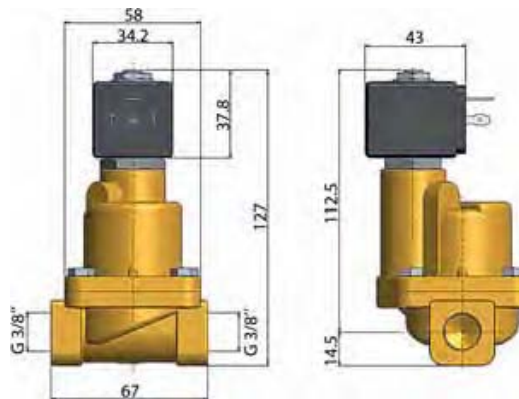

Drawing 017

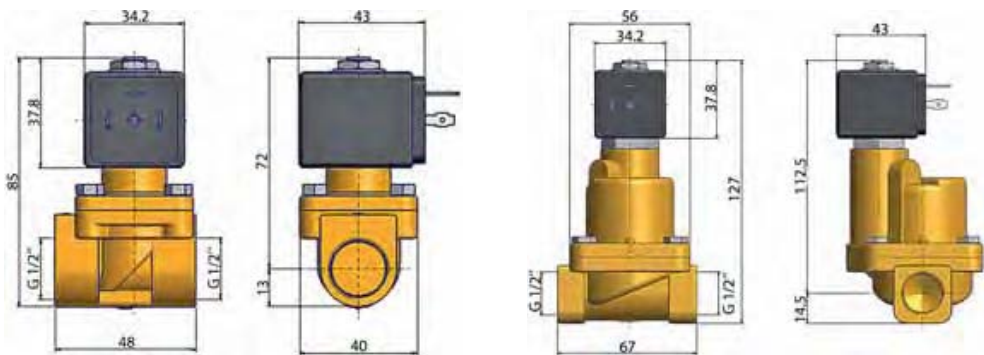

Drawing 038

Drawing 016

## 2 WAY VALVES

# 2/2

## HOT WATER AND STEAM VALVES

### PILOT OPERATED

BRASS

PIPE MOUNTING

NORMALLY CLOSED

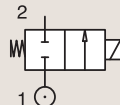

Port size	Orifice Ø	Flow factors			Operating Pressure Differential			Fluid Temp.		Seat Seal	Parker Valves			Power		Coil Group	Dwg. No.
		Kv l/min	KV m <sup>3</sup> /h	Qn m <sup>3</sup> /h	Min bar	Max (MOPD) bar	DC bar	Min °C	Max °C		Valve Order Number	Valve Type	Coil Type	AC W	DC W		
3/4"	18	37	2.22	-	0.5	14	-	-30	160	PTFE	364530 <sub>1</sub>	PM156.2CR	ZB09	9	-	20.1	039
	27	193	11.6	-	0.5	10	-	-30	180	PTFE	362264	PM135CT	ZH14	14	-	20.2	018
	27	193	11.6	-	0.5	-	10	-30	180	PTFE	362264	PM135CT	ZH16	-	16	20.2	018
1"	18	42	2.52	-	0.5	14	-	-30	160	PTFE	364535 <sub>1</sub>	PM156.2DR	ZB09	9	-	20.1	040
	27	193	11.6	-	0.5	10	-	-30	180	PTFE	362265	PM135DT	ZH14	14	-	20.2	019
	27	193	11.6	-	0.5	-	10	-30	180	PTFE	362265	PM135DT	ZH16	-	16	20.2	019

**Notes:**

1. Maximum pressure for steam: 6.5 Bar (160°C)



## 2 WAY VALVES



For this page	Port size	Orifice (mm)	Kv (l/min)	MOPD (bar)	Fluid Temp (°C)	Amb Temp (°C)
From	3/4"	18	37	10	-30	-10
To	1"	27	193	14	180	50

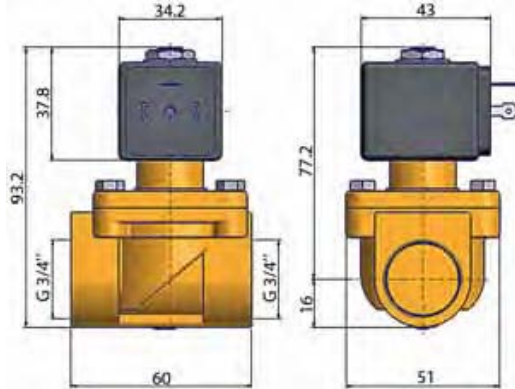

Drawing 039

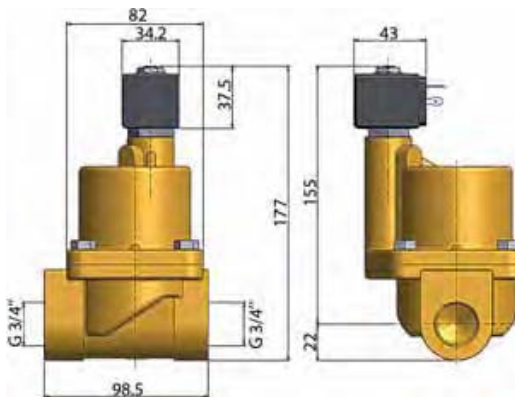

Drawing 018

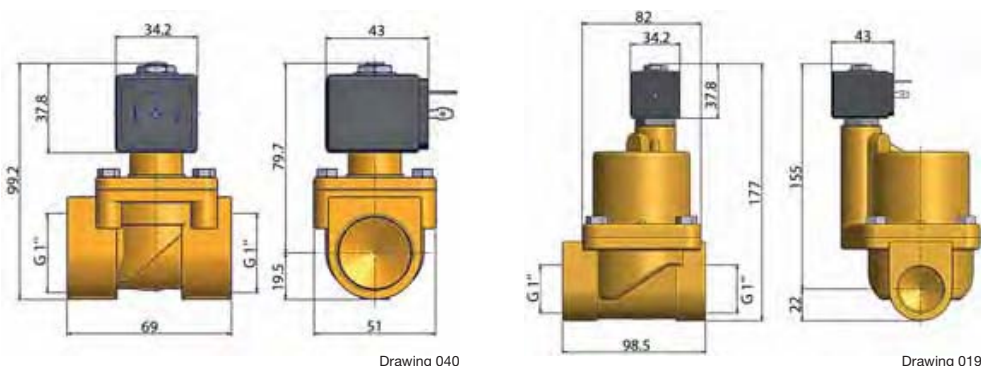

Drawing 040

Drawing 019

## 2 WAY VALVES

# 2/2

## HOT WATER AND STEAM VALVES

### PILOT OPERATED

BRASS

PIPE MOUNTING

**NORMALLY CLOSED**

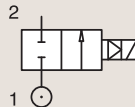

Port size	Orifice Ø	Flow factors			Operating Pressure Differential			Fluid Temp.		Seat Seal	Parker LUCIFER® Valves			Power		Coil Group	Dwg. No.
					Min	Max(MOPD)	Min	Max	Valve Ref.		Housing Ref.	Coil Ref.	AC W	DC W			
					bar	AC bar									DC bar		
BSP	mm	Kv l/min	KV m³/h	Qn l/min	bar	AC bar	DC bar	°C	°C				AC W	DC W			
1/2"	11	36	2.16	-	0.2	10	4	0	120	EPDM	E321K1503	4270	481000	8	8	2.0	3427
	11	36	2.16	-	0.2	10	-	0	100	EPDM	E321K1503	4270	483520	9	-	2.0	3427
	11	36	2.16	-	0.2	10	-	0	120	EPDM	E321K1503	4270	486992	10	-	2.0	3427



## 2 WAY VALVES



For this page	Port size	Orifice (mm)	Kv (l/min)	MOPD (bar)	Fluid Temp (°C)	Amb Temp (°C)
From	1/2"	11	36	4	0	-10
To	1/2"	11	36	10	120	50

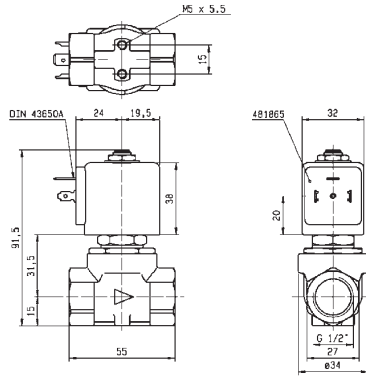

Drawing 3427

## 2 WAY VALVES

## 2 WAY VALVES



VALVES FOR HYDRAULIC OIL AND NEUTRAL LIQUIDS (UP TO 100 BAR)



# 2/2

Actuation	Body	Function	Port Size	Orifice (mm)	Flow Factor Kv(l/min)	MOPD (bar)	Max Fluid Temp. (°C)	Page Parker Valves	Page Parker LUCIFER® Valves	
Direct Operated	Brass/Pipe mounting	Normally Closed	1/8"	1.5 to 2.5	3.5	70	130	-	142	
			1/4"	1.2 to 3	4.5	100	130	-	142	
			3/8"	4 to 6	12	10	120	-	144	
		Normally Open	1/8"	2.5	3.5	30	140	-	144	
			1/4"	1.5 to 2.5	3.5	40	140	-	144	
	Brass/Sub-base mounting	Normally Closed	5 mm	1.5 to 3	4.5	100	130	-	146	
Pilot Operated	Brass/Pipe mounting	Normally Closed	1/4"	8	36	40	140	-	148	
			3/8"	11	50	40	140	-	148	
			1/2"	15	60	40	140	-	150	
		Normally Open	1/4"	8	36	40	140	-	152	
			3/8"	11	50	40	140	-	152	
			1/2"	15	60	40	140	-	152	
		Brass/Sub-base mounting	Normally Closed	14 mm	14	45	40	140	-	154
			Normally Open	14 mm	14	45	40	120	-	154

## 2 WAY VALVES

# 2/2

## VALVES FOR HYDRAULIC OIL AND NEUTRAL LIQUIDS (UP TO 100 BAR) DIRECT OPERATED



Industrial Equipment



Commercial Equipment



Heating Systems

### BRASS PIPE MOUNTING

#### NORMALLY CLOSED

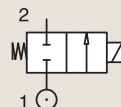

Port size	Orifice Ø	Flow factors			Operating Pressure Differential			Fluid Temp.		Seat Seal	Parker LUCIFER® Valves			Power		Coil Group	Dwg. No.
		Kv	KV	Qn	Min	Max(MOPD)	DC	Min	Max		Valve Ref.	Housing Ref.	Coil Ref.	AC W	DC W		
BSP	mm	l/min	m³/h	l/min	bar	AC bar	DC bar	°C	°C								
1/8"	1.5	1.5	0.09	80	0	60	25	-30	75	PCTFE	E121K14	2995	481865	8	9	2.0	3510
	1.5	1.5	0.09	80	0	70	30	-30	75	PCTFE	E121K14	4270	481000	8	8	2.0	3510
	1.5	1.5	0.09	80	0	70	55	-30	75	PCTFE	E121K14	4270	486265	14	14	2.0	3510
	2.5	3.5	0.21	220	0	28	10	-30	100	Ruby	E121K23	2995	481865	8	9	2.0	3510
	2.5	3.5	0.21	220	0	34	12	-30	130	Ruby	E121K23	4270	481000	8	8	2.0	3510
1/4"	2.5	3.5	0.21	220	0	50	22	-30	120	Ruby	E121K23	4270	486265	14	14	2.0	3510
	1.2	0.85	0.05	50	0	80	36	-30	100	Ruby	E121K65	2995	481865	8	9	2.0	3510
	1.2	0.85	0.05	50	0	100	43	-30	130	Ruby	E121K65	4270	481000	8	8	2.0	3510
	1.2	0.85	0.05	50	0	100	75	-30	120	Ruby	E121K65	4270	486265	14	14	2.0	3510
	1.5	1.5	0.09	80	0	60	25	-30	75	PCTFE	E121K04	2995	481865	8	9	2.0	3510
	1.5	1.5	0.09	80	0	70	30	-30	75	PCTFE	E121K04	4270	481000	8	8	2.0	3510
	1.5	1.5	0.09	80	0	70	55	-30	75	PCTFE	E121K04	4270	486265	14	14	2.0	3510
	1.5	1.5	0.09	80	0	60	25	-30	100	Ruby	E121K67	2995	481865	8	9	2.0	3510
	1.5	1.5	0.09	80	0	75	30	-30	130	Ruby	E121K67	4270	481000	8	8	2.0	3510
	1.5	1.5	0.09	80	0	100	55	-30	120	Ruby	E121K67	4270	486265	14	14	2.0	3510
	2.5	3.5	0.21	220	0	28	10	-30	100	Ruby	E121K63	2995	481865	8	9	2.0	3510
	2.5	3.5	0.21	220	0	34	12	-30	130	Ruby	E121K63	4270	481000	8	8	2.0	3510
	2.5	3.5	0.21	220	0	50	22	-30	120	Ruby	E121K63	4270	486265	14	14	2.0	3510
	3	4.5	0.27	320	0	20	7	-30	75	PCTFE	E121K03	2995	481865	8	9	2.0/3.0	3510
	3	4.5	0.27	320	0	25	8.5	-30	75	PCTFE	E121K03	4270	481000	8	8	2.0/3.0	3510



2 WAY VALVES



For this page	Port size	Orifice (mm)	Kv (l/min)	MOPD (bar)	Fluid Temp (°C)	Amb Temp (°C)
From	1/8"	1.2	0.85	7	-30	-10
To	1/4"	3	4.5	100	130	50

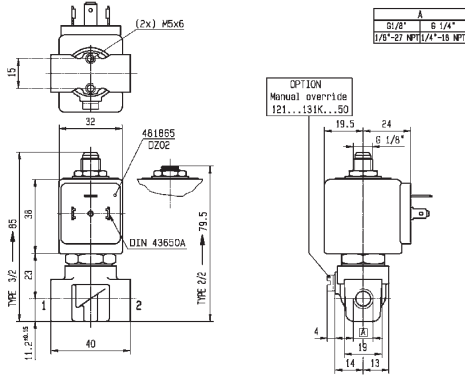

Drawing 3510



## 2 WAY VALVES

# 2/2

### VALVES FOR HYDRAULIC OIL AND NEUTRAL LIQUIDS (UP TO 100 BAR) DIRECT OPERATED

#### BRASS

#### PIPE MOUNTING

#### NORMALLY CLOSED

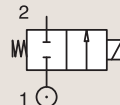

Port size	Orifice Ø	Flow factors			Operating Pressure Differential			Fluid Temp.		Seat Seal	Parker LUCIFER® Valves			Power		Coil Group	Dwg. No.
					Min	Max(MOPD)		Min	Max		Valve Ref.	Housing Ref.	Coil Ref.	AC W	DC W		
						bar	AC bar										
1/4"	3	4.5	0.27	320	0	36	15	-30	75	PCTFE	E121K03	4270	486265	14	14	2.0/3.0	3510
	3	4.5	0.27	320	0	20	7	-30	100	Ruby	E121K64	2995	481865	8	9	2.0	3510
	3	4.5	0.27	320	0	25	8.5	-30	130	Ruby	E121K64	4270	481000	8	8	2.0	3510
	3	4.5	0.27	320	0	36	15	-30	120	Ruby	E121K64	4270	486265	14	14	2.0	3510
3/8"	4	7.5	0.45	480	0	10	4	-10	100	FKM	121K3206	2995	481865	8	9	2.0	3551
	4	7.5	0.45	480	0	10	5	-10	120	FKM	121K3206	4270	481000	8	8	2.0	3551
	4	7.5	0.45	480	0	10	10	-10	120	FKM	121K3206	4270	486265	14	14	2.0	3551
	5	11	0.66	750	0	7	2	-10	100	FKM	121K3106	2995	481865	8	9	2.0	3551
	5	11	0.66	750	0	7	2.8	-10	120	FKM	121K3106	4270	481000	8	8	2.0	3551
	5	11	0.66	750	0	7	5	-10	120	FKM	121K3106	4270	486265	14	14	2.0	3551
	6	12	0.72	1100	0	5	1.1	-10	100	FKM	121K3306	2995	481865	8	9	2.0/14.2	3551
	6	12	0.72	1100	0	5	1.5	-10	120	FKM	121K3306	4270	481000	8	8	2.0/14.2	3551
	6	12	0.72	1100	0	5	3	-10	120	FKM	121K3306	4270	486265	14	14	2.0/14.2	3551

#### BRASS

#### PIPE MOUNTING

#### NORMALLY OPEN

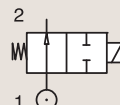

Port size	Orifice Ø	Flow factors			Operating Pressure Differential			Fluid Temp.		Seat Seal	Parker LUCIFER® Valves			Power		Coil Group	Dwg. No.
					Min	Max(MOPD)		Min	Max		Valve Ref.	Housing Ref.	Coil Ref.	AC W	DC W		
						bar	AC bar										
1/8"	2.5	3.5	0.21	-	0	30	-	-30	140	Ruby	122K9363	4270	481044	14	-	2.2	3510
	2.5	3.5	0.21	-	0	30	30	-30	140	Ruby	122K9363	4270	486265	14	14	2.2	3510
1/4"	1.5	1.5	0.09	9.6	0	30	30	-10	100	PCTFE	122K84	2995	481865	8	9	2.0	3510
	1.5	1.5	0.09	9.6	0	30	30	-10	100	PCTFE	122K84	4270	481000	8	8	2.0	3510
	1.5	1.5	0.09	9.6	0	30	30	-10	120	PCTFE	122K84	4270	486265	14	14	2.0	3510
	1.5	1.5	0.09	80	0	40	40	-30	100	Ruby	122K8408	2995	481865	8	9	2.1	3510
	1.5	1.5	0.09	80	0	40	40	-30	130	Ruby	122K8408	4270	481000	8	8	2.1	3510
	1.5	1.5	0.09	80	0	40	40	-30	130	Ruby	122K8408	4270	486265	14	14	2.0	3510
	2.5	3.5	0.21	-	0	30	-	-30	140	Ruby	122K8363	4270	481044	14	-	2.2	3510
	2.5	3.5	0.21	-	0	30	30	-30	140	Ruby	122K8363	4270	486265	14	14	2.2	3510



## 2 WAY VALVES



For this page	Port size	Orifice (mm)	Kv (l/min)	MOPD (bar)	Fluid Temp (°C)	Amb Temp (°C)
From	1/8"	1.5	1.5	1.1	-30	-10
To	3/8"	6	12	40	140	50

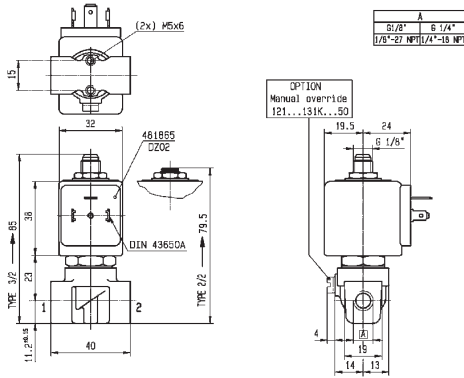

Drawing 3510

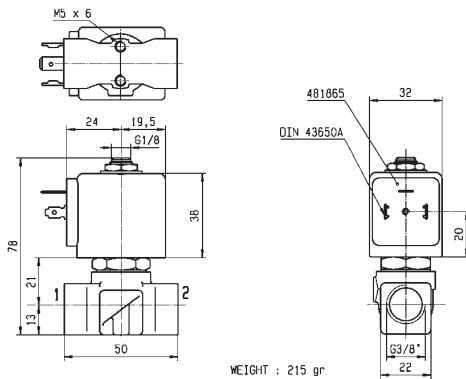

Drawing 3551

## 2 WAY VALVES

# 2/2

### VALVES FOR HYDRAULIC OIL AND NEUTRAL LIQUIDS (UP TO 100 BAR) DIRECT OPERATED

BRASS

SUB-BASE MOUNTING

**NORMALLY CLOSED**

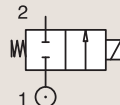

Port size	Orifice Ø mm	Flow factors			Operating Pressure Differential Max(MOPD)			Fluid Temp. Min Max °C °C		Seat Seal	Parker LUCIFER® Valves			Power		Coil Group	Dwg. No.
											Valve Ref.	Housing Ref.	Coil Ref.	AC W	DC W		
SB	1.5	1.5	0.09	80	0	60	25	-30	100	Ruby	121F67	2995	481865	8	9	2.0	3509
	1.5	1.5	0.09	80	0	75	30	-30	130	Ruby	121F67	4270	481000	8	8	2.0	3509
	1.5	1.5	0.09	80	0	100	55	-30	120	Ruby	121F67	4270	486265	14	14	2.0	3509
	1.5	1.5	0.09	80	0	60	25	-30	75	PCTFE	E121F44	2995	481865	8	9	2.0	3509
	1.5	1.5	0.09	80	0	70	30	-30	75	PCTFE	E121F44	4270	481000	8	8	2.0	3509
	1.5	1.5	0.09	80	0	70	55	-30	75	PCTFE	E121F44	4270	486265	14	14	2.0	3509
	2.5	3.5	0.21	220	0	14	10	-10	100	FKM	121F4706	2995	481865	8	9	2.0	3509
	2.5	3.5	0.21	220	0	14	9	-10	120	FKM	121F4706	4270	481000	8	8	2.0	3509
	2.5	3.5	0.21	220	0	14	14	-10	120	FKM	121F4706	4270	486265	14	14	2.0	3509
	2.5	3.5	0.21	220	0	28	10	-30	100	Ruby	121F63	2995	481865	8	9	2.0	3509
	2.5	3.5	0.21	220	0	34	12	-30	130	Ruby	121F63	4270	481000	8	8	2.0	3509
	2.5	3.5	0.21	220	0	50	22	-30	120	Ruby	121F63	4270	486265	14	14	2.0	3509
	3	4.5	0.27	320	0	20	7	-30	100	Ruby	121F64	2995	481865	8	9	2.0	3509
	3	4.5	0.27	320	0	25	8.5	-30	130	Ruby	121F64	4270	481000	8	8	2.0	3509
	3	4.5	0.27	320	0	36	15	-30	120	Ruby	121F64	4270	486265	14	14	2.0	3509
	3	4.5	0.27	320	0	20	7	-30	75	PCTFE	E121F43	2995	481865	8	9	2.0	3509
	3	4.5	0.27	320	0	25	8.5	-30	75	PCTFE	E121F43	4270	481000	8	8	2.0	3509
	3	4.5	0.27	320	0	36	15	-30	75	PCTFE	E121F43	4270	486265	14	14	2.0	3509

## 2 WAY VALVES



For this page	Port size	Orifice (mm)	Kv (l/min)	MOPD (bar)	Fluid Temp (°C)	Amb Temp (°C)
From	5 mm	1.5	1.5	7	-30	-10
To	5 mm	3	4.5	100	130	50

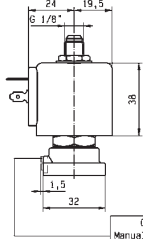
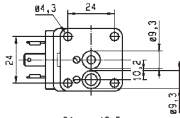

OPTION  
Manual override  
121...131F...50

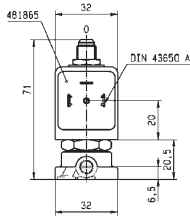

Drawing 3509

## 2 WAY VALVES

# 2/2

### VALVES FOR HYDRAULIC OIL AND NEUTRAL LIQUIDS (UP TO 100 BAR) PILOT OPERATED



Commercial Equipment



Industrial Equipment



Heating Systems

BRASS  
PIPE MOUNTING

**NORMALLY CLOSED**

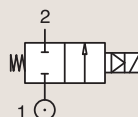

Port size	Orifice Ø	Flow factors			Operating Pressure Differential			Fluid Temp.		Seat Seal	Parker LUCIFER® Valves			Power		Coil Group	Dwg. No.
											Valve Ref.	Housing Ref.	Coil Ref.	AC W	DC W		
BSP	mm	Kv l/min	KV m³/h	Qn l/min	Min bar	AC bar	DC bar	Min °C	Max °C		Valve Ref.	Housing Ref.	Coil Ref.	AC W	DC W		
1/4"	8	36	2.16	1600	0.3	40	25	-10	100	NBR	E321H11 <sup>12</sup>	2995	481865	8	9	2.0	3523
	8	36	2.16	1600	0.3	40	30	-10	100	NBR	E321H11 <sup>12</sup>	4270	481000	8	8	2.0	3523
	8	36	2.16	1600	0.3	40	40	-10	100	NBR	E321H11 <sup>12</sup>	4270	486265	14	14	2.0	3523
	8	36	2.16	-	0.3	40	25	-10	100	FKM	E321H21 <sup>12</sup>	2995	481865	8	9	2.0	3523
	8	36	2.16	-	0.3	40	30	-10	120	FKM	E321H21 <sup>12</sup>	4270	481000	8	8	2.0	3523
	8	36	2.16	-	0.3	40	40	-10	140	FKM	E321H21 <sup>12</sup>	4270	486265	14	14	2.0	3523
3/8"	11	50	3	2800	0.3	40	25	-10	100	NBR	E321H13 <sup>12</sup>	2995	481865	8	9	2.0	3521
	11	50	3	2800	0.3	40	30	-10	100	NBR	E321H13 <sup>12</sup>	4270	481000	8	8	2.0	3521
	11	50	3	2800	0.3	40	40	-10	100	NBR	E321H13 <sup>12</sup>	4270	486265	14	14	2.0	3521
	11	50	3	-	0.3	40	25	-10	100	FKM	E321H23 <sup>12</sup>	2995	481865	8	9	2.0	3521
	11	50	3	-	0.3	40	30	-10	120	FKM	E321H23 <sup>12</sup>	4270	481000	8	8	2.0	3521
	11	50	3	-	0.3	40	40	-10	140	FKM	E321H23 <sup>12</sup>	4270	486265	14	14	2.0	3521
	11	36	2.16	-	0.2	20	-	-10	100	Ruby	E321K63	2995	483510	9	-	2.0	3429
	11	36	2.16	-	0.2	30	-	-10	140	Ruby	E321K63	4270	488553	9	-	2.0	3429
	11	36	2.16	-	0.2	4	4	-10	120	Ruby	E321K63	-	492190	11	9	2.0	3429

**Notes:**

1. Minimum pressure differential = 0.3 bar for opening and 0 bar for closing
2. Pilot seat disc in synthetic Ruby



## 2 WAY VALVES



For this page	Port size	Orifice (mm)	Kv (l/min)	MOPD (bar)	Fluid Temp (°C)	Amb Temp (°C)
From	1/4"	8	36	3	-10	-10
To	3/8"	11	50	40	140	50

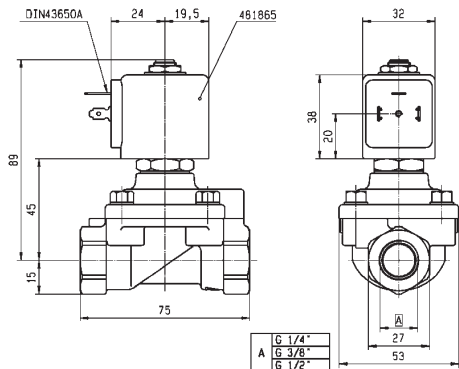

Drawing 3523

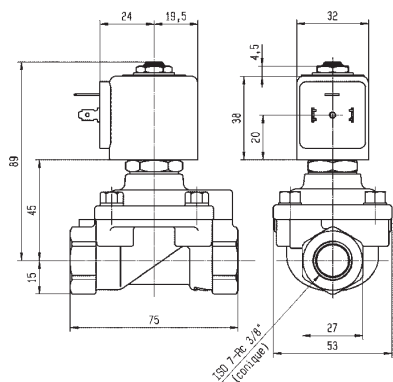

Drawing 3521

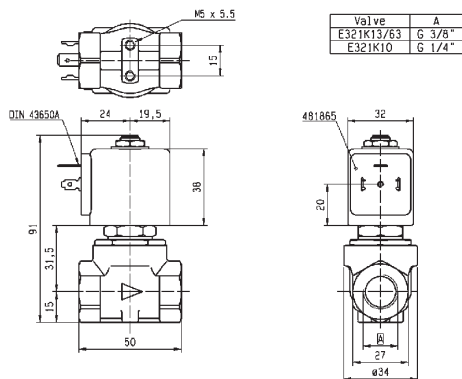

Drawing 3429

## 2 WAY VALVES

# 2/2

### VALVES FOR HYDRAULIC OIL AND NEUTRAL LIQUIDS (UP TO 100 BAR) PILOT OPERATED

BRASS

PIPE MOUNTING

**NORMALLY CLOSED**

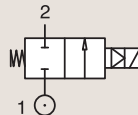

Port size	Orifice Ø	Flow factors			Operating Pressure Differential			Fluid Temp.		Seat Seal	Parker LUCIFER® Valves			Power		Coil Group	Dwg. No.
		Kv l/min	KV m³/h	Qn l/min	Min bar	Max(MOPD) bar	DC bar	Min °C	Max °C		Valve Ref.	Housing Ref.	Coil Ref.	AC W	DC W		
1/2"	15	60	3.6	3150	0.3	40	25	-10	100	NBR	E321H15 <sub>12</sub>	2995	481865	8	9	2.0	3522
	15	60	3.6	3150	0.3	40	30	-10	100	NBR	E321H15 <sub>12</sub>	4270	481000	8	8	2.0	3522
	15	60	3.6	3150	0.3	40	40	-10	100	NBR	E321H15 <sub>12</sub>	4270	486265	14	14	2.0	3522
	15	60	3.6	-	0.3	40	25	-10	100	FKM	E321H25 <sub>12</sub>	2995	481865	8	9	2.0/14.2	3522
	15	60	3.6	-	0.3	40	30	-10	120	FKM	E321H25 <sub>12</sub>	-	483371	8	8	2.0/14.2	3522
	15	60	3.6	-	0.3	40	40	-10	140	FKM	E321H25 <sub>12</sub>	4270	486265	14	14	2.0/14.2	3522

**Notes:**

1. Minimum pressure differential = 0.3 bar for opening and 0 bar for closing
2. Pilot seat disc in synthetic Ruby



## 2 WAY VALVES



For this page	Port size	Orifice (mm)	Kv (l/min)	MOPD (bar)	Fluid Temp (°C)	Amb Temp (°C)
From	1/2"	15	60	25	-10	-10
To	1/2"	15	60	40	140	50

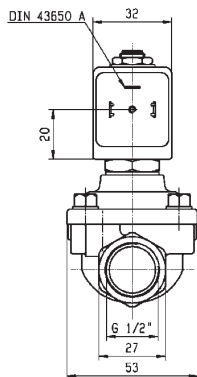
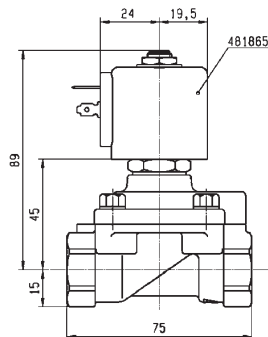

Drawing 3522

## 2 WAY VALVES

# 2/2

## VALVES FOR HYDRAULIC OIL AND NEUTRAL LIQUIDS (UP TO 100 BAR) PILOT OPERATED

### BRASS

### PIPE MOUNTING

### NORMALLY OPEN

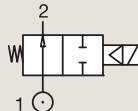

Port size	Orifice Ø	Flow factors			Operating Pressure Differential			Fluid Temp.		Seat Seal	Parker LUCIFER® Valves			Power		Coil Group	Dwg. No.
		Kv l/min	KV m³/h	Qn l/min	Min bar	AC bar	DC bar	Min °C	Max °C		Valve Ref.	Housing Ref.	Coil Ref.	AC W	DC W		
1/4"	8	36	2.16	-	0.3	40	40	-10	100	FKM	322H7106 <sup>12</sup>	2995	481865	8	9	2.0/14.1	3523
	8	36	2.16	-	0.3	40	40	-10	120	FKM	322H7106 <sup>12</sup>	4270	481000	8	8	2.0/14.1	3523
	8	36	2.16	-	0.3	40	40	-10	140	FKM	322H7106 <sup>12</sup>	4270	486265	14	14	2.0/14.1	3523
3/8"	11	50	3	3240	0.3	40	40	-10	75	NBR	322H73 <sup>12</sup>	2995	481865	8	9	2.0	3523
	11	50	3	3240	0.3	40	40	-10	75	NBR	322H73 <sup>12</sup>	4270	481000	8	8	2.0	3523
	11	50	3	3240	0.3	40	40	-10	75	NBR	322H73 <sup>12</sup>	4270	486265	14	14	2.0	3523
	11	50	3	-	0.3	40	40	-10	100	FKM	322H7306 <sup>12</sup>	2995	481865	8	9	2.0/14.1	3523
	11	50	3	-	0.3	40	40	-10	100	FKM	322H7306 <sup>12</sup>	4270	481000	8	8	2.0/14.1	3523
	11	50	3	-	0.3	40	40	-10	140	FKM	322H7306 <sup>12</sup>	4270	486265	14	14	2.0/14.1	3523
1/2"	15	60	3.6	3890	0.3	20	20	-10	100	FKM	322G7506 <sup>1</sup>	2995	481865	8	9	2.0	3522
	15	60	3.6	3890	0.3	20	20	-10	100	FKM	322G7506 <sup>1</sup>	4270	481000	8	8	2.0	3522
	15	60	3.6	3890	0.3	20	20	-10	100	FKM	322G7506 <sup>1</sup>	4270	486265	14	14	2.0	3522
	15	60	3.6	3890	0.3	40	40	-10	100	NBR	322H75 <sup>12</sup>	2995	481865	8	9	2.0	3522
	15	60	3.6	3890	0.3	40	40	-10	100	NBR	322H75 <sup>12</sup>	4270	481000	8	8	2.0	3522
	15	60	3.6	3890	0.3	40	40	-10	100	NBR	322H75 <sup>12</sup>	4270	486265	14	14	2.0	3522
	15	60	3.6	-	0.3	40	40	-10	100	FKM	322H7506 <sup>12</sup>	2995	481865	8	9	2.0/14.1	3522
	15	60	3.6	-	0.3	40	40	-10	120	FKM	322H7506 <sup>12</sup>	4270	481000	8	8	2.0/14.1	3522
	15	60	3.6	-	0.3	40	40	-10	140	FKM	322H7506 <sup>12</sup>	4270	486265	14	14	2.0/14.1	3522

#### Notes:

1. Minimum pressure differential = 0.3 bar for opening and 0 bar for closing
2. Pilot seat disc in synthetic Ruby



## 2 WAY VALVES



For this page	Port size	Orifice (mm)	Kv (l/min)	MOPD (bar)	Fluid Temp (°C)	Amb Temp (°C)
From	1/4"	8	36	20	-10	-10
To	1/2"	15	60	40	140	50

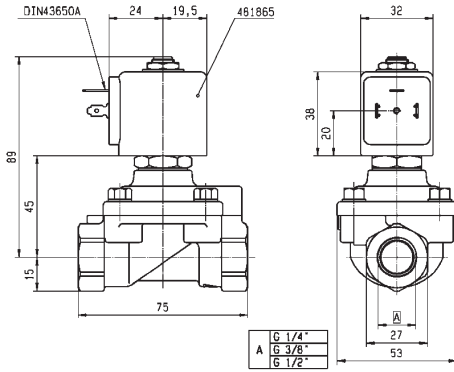

Drawing 3523

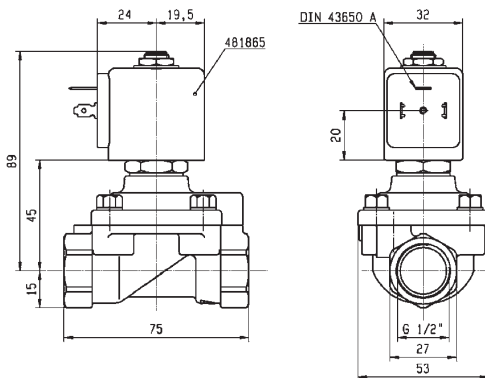

Drawing 3522

## 2 WAY VALVES

# 2/2

### VALVES FOR HYDRAULIC OIL AND NEUTRAL LIQUIDS (UP TO 100 BAR) PILOT OPERATED

BRASS

SUB-BASE MOUNTING

**NORMALLY CLOSED**

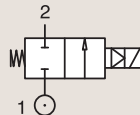

Port size	Orifice Ø	Flow factors			Operating Pressure Differential			Fluid Temp.		Seat Seal	Parker LUCIFER® Valves			Power		Coil Group	Dwg. No.
					Min	Max(MOPD)		Min	Max		Valve Ref.	Housing Ref.	Coil Ref.	AC W	DC W		
					bar	AC bar	DC bar	°C	°C								
BSP	mm	Kv l/min	KV m³/h	Qn l/min	bar	AC bar	DC bar	°C	°C	FKM							
	14	45	2.7	-	0.3	40	25	-10	100	FKM	E321F3202 <sub>12</sub>	2995	481865	8	9	2.0	3520
SB	14	45	2.7	-	0.3	40	30	-10	120	FKM	E321F3202 <sub>12</sub>	4270	481000	8	8	2.0	3520
	14	45	2.7	-	0.3	40	40	-10	140	FKM	E321F3202 <sub>12</sub>	4270	486265	14	14	2.0	3520

**Notes:**

1. Minimum pressure differential = 0.3 bar for opening and 0 bar for closing
2. Pilot seat disc in synthetic Ruby

BRASS

SUB-BASE MOUNTING

**NORMALLY OPEN**

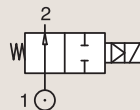

Port size	Orifice Ø	Flow factors			Operating Pressure Differential			Fluid Temp.		Seat Seal	Parker LUCIFER® Valves			Power		Coil Group	Dwg. No.
					Min	Max(MOPD)		Min	Max		Valve Ref.	Housing Ref.	Coil Ref.	AC W	DC W		
					bar	AC bar	DC bar	°C	°C								
BSP	mm	Kv l/min	KV m³/h	Qn l/min	bar	AC bar	DC bar	°C	°C	FKM							
	14	45	2.7	-	0.3	40	40	0	100	FKM	322F7206 <sub>12</sub>	2995	481865	8	9	2.1/14.1	3520
SB	14	45	2.7	-	0.3	40	40	0	120	FKM	322F7206 <sub>12</sub>	4270	481000	8	8	2.1/14.1	3520

**Notes:**

1. Minimum pressure differential = 0.3 bar for opening and 0 bar for closing
2. Pilot seat disc in synthetic Ruby



## 2 WAY VALVES



For this page	Port size	Orifice (mm)	Kv (l/min)	MOPD (bar)	Fluid Temp (°C)	Amb Temp (°C)
From	14 mm	14	45	25	-10	-10
To	14 mm	14	45	40	140	50

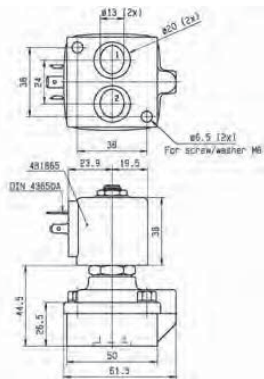

Drawing 3520

## 2 WAY VALVES

## 2 WAY VALVES



### HIGH CORROSION RESISTANT VALVES (303 STAINLESS STEEL)



# 2/2

Actuation	Body	Function	Port Size	Orifice (mm)	Flow Factor Kv(l/min)	MOPD (bar)	Max Fluid Temp. (°C)	Page Parker Valves	Page Parker LUCIFER® Valves
Direct Operated	303 Stainless St./Pipe mounting	Normally Closed	1/4"	1.5 to 5	10	100	180	-	158
		Normally Open	1/4"	2.5	3	12	120	-	162

## 2 WAY VALVES

# 2/2

## HIGH CORROSION RESISTANT VALVES (303 STAINLESS STEEL) DIRECT OPERATED



Process



Commercial Equipment

### 303 STAINLESS ST. PIPE MOUNTING

#### NORMALLY CLOSED

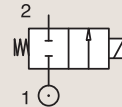

Port size	Orifice Ø	Flow factors			Operating Pressure Differential			Fluid Temp.		Seat Seal	Parker LUCIFER® Valves			IS	Power		Coil Group	Dwg. No.
		Kv l/min	KV m³/h	Qn l/min	Min bar	Max(MOPD) AC bar	DC bar	Min °C	Max °C		Valve Ref.	Housing Ref.	Coil Ref.		AC W	DC W		
1/4"	1.5	1.5	0.09	80	0	20	20	-10	100	FKM	121V5406	2995	481865	8	9	2.0	8116	
	1.5	1.5	0.09	80	0	20	20	-10	120	FKM	121V5406	4270	481000	8	8	2.0	8116	
	1.5	1.5	0.09	80	0	60	25	0	100	Ruby	121V5463 <sub>1</sub>	2995	481865	8	9	2.0	8116	
	1.5	1.5	0.09	80	0	75	30	0	130	Ruby	121V5463 <sub>1</sub>	4270	481000	8	8	2.0	8116	
	1.5	1.5	0.09	80	0	100	55	0	140	Ruby	121V5463 <sub>1</sub>	4270	486265	14	14	2.0	8116	
	1.5	1.5	0.09	80	0	-	8	-20	75	PUR	121V5497 <sub>2</sub>	2995	482740	-	1.6	3.0/6.0/8.0	8024	
	1.5	1.5	0.09	80	0	10	10	-20	75	PUR	121V5497 <sub>2</sub>	-	495900	2.5	2	3.0/6.0/8.0	8024	
	1.5	1.5	0.09	80	0	-	10	-20	75	PUR	121V5497 <sub>2</sub>	-	495910	*	-	0.3 to 3	3.0/6.0/8.0	8024
	1.5	1.5	0.09	80	0	-	8	-20	75	PUR	121V5497 <sub>2</sub>	2995	496125	-	1.6	3.0/6.0/8.0	8024	
	2.5	3.5	0.21	220	0	14	7	-10	100	FKM	121V5706	2995	481865	8	9	2.0	8116	
	2.5	3.5	0.21	220	0	14	9	-10	120	FKM	121V5706	4270	481000	8	8	2.0	8116	
	2.5	3.5	0.21	220	0	14	14	-10	120	FKM	121V5706	4270	486265	14	14	2.0	8116	
	2.5	3.5	0.21	220	0	28	10	0	100	Ruby	121V5763 <sub>1</sub>	2995	481865	8	9	2.0	8116	
	2.5	3.5	0.21	220	0	34	12	0	130	Ruby	121V5763 <sub>1</sub>	4270	481000	8	8	2.0	8116	
	2.5	3.5	0.21	220	0	50	22	0	140	Ruby	121V5763 <sub>1</sub>	4270	486265	14	14	2.0	8116	
	3	4.5	0.27	315	0	10	7	-10	100	FKM	121V5306	2995	481865	8	9	2.0	8116	
	3	4.5	0.27	315	0	10	8.5	-10	120	FKM	121V5306	4270	481000	8	8	2.0	8116	
	3	4.5	0.27	315	0	10	10	-10	120	FKM	121V5306	4270	486265	14	14	2.0	8116	
	3	4.5	0.27	315	0	20	7	0	100	Ruby	121V5363 <sub>1</sub>	2995	481865	8	9	2.0	8116	
	3	4.5	0.27	315	0	25	8.5	0	130	Ruby	121V5363 <sub>1</sub>	4270	481000	8	8	2.0	8116	
3	4.5	0.27	315	0	36	15	0	140	Ruby	121V5363 <sub>1</sub>	4270	486265	14	14	2.0	8116		

#### Notes:

1. Valve only compatible with hydraulic oil and neutral liquids
2. Valve compatible with water only up to 40°C



## 2 WAY VALVES



For this page	Port size	Orifice (mm)	Kv (l/min)	MOPD (bar)	Fluid Temp (°C)	Amb Temp (°C)
From	1/4"	1.5	1.5	7	-20	-20
To	1/4"	3	4.5	100	140	50

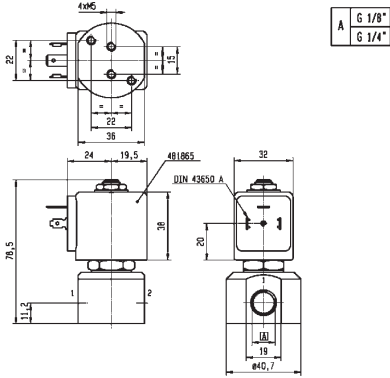

Drawing 8116

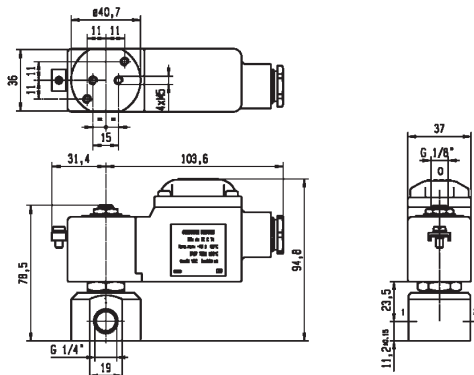

Drawing 8024

## 2 WAY VALVES

# 2/2

## HIGH CORROSION RESISTANT VALVES (303 STAINLESS STEEL) DIRECT OPERATED

### 303 STAINLESS ST. PIPE MOUNTING

### NORMALLY CLOSED

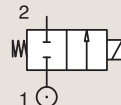

Port size	Orifice Ø	Flow factors			Operating Pressure Differential			Fluid Temp.		Seat Seal	Parker LUCIFER® Valves			IS	Power		Coil Group	Dwg. No.
											Valve Ref.	Housing Ref.	Coil Ref.		AC W	DC W		
1/4"	3	3.5	0.21	220	0	-	2	-20	75	PUR	121V5397 <sub>2</sub>	2995	482740	-	1.6	3.0/6.0/8.0	8024	
	3	3.5	0.21	220	0	4.5	4	-20	75	PUR	121V5397 <sub>2</sub>	-	495900	2.5	2	3.0/6.0/8.0	8024	
	3	3.5	0.21	220	0	-	4.5	-20	75	PUR	121V5397 <sub>2</sub>	-	495910	*	-	0.3 to 3	3.0/6.0/8.0	8024
	3	3.5	0.21	220	0	-	2	-20	75	PUR	121V5397 <sub>2</sub>	2995	496125	-	1.6	3.0/6.0/8.0	8024	
	4	7	0.42	450	0	10	4	-10	100	FKM	121V5206	2995	481865	8	9	2.0	8116	
	4	7	0.42	450	0	10	5	-10	120	FKM	121V5206	4270	481000	8	8	2.0	8116	
	4	7	0.42	450	0	10	10	-10	120	FKM	121V5206	4270	486265	14	14	2.0	8116	
	4	7	0.42	450	0	3.5	3.5	0	100	PTFE	121V5212 <sub>1</sub>	2995	481865	8	9	2.0	8116	
	4	7	0.42	450	0	3.5	3.5	0	130	PTFE	121V5212 <sub>1</sub>	4270	481000	8	8	2.0	8116	
	4	7	0.42	450	0	3.5	3.5	0	130	PTFE	121V5212 <sub>1</sub>	4270	486265	14	14	2.0	8116	
	4	7	0.42	450	0	12	4	0	100	Ruby	121V5263 <sub>1</sub>	2995	481865	8	9	2.0	8116	
	4	7	0.42	450	0	15	5	0	130	Ruby	121V5263 <sub>1</sub>	4270	481000	8	8	2.0	8116	
	4	7	0.42	450	0	22	10	0	180	Ruby	121V5263 <sub>1</sub>	4270	486265	14	14	2.0	8116	
	5	10	0.6	750	0	7	2	-10	100	FKM	121V5106	2995	481865	8	9	2.0	8116	
	5	10	0.6	750	0	7	2.8	-10	120	FKM	121V5106	4270	481000	8	8	2.0	8116	
	5	10	0.6	750	0	7	5	-10	120	FKM	121V5106	4270	486265	14	14	2.0	8116	
	5	10	0.6	-	0	2.8	2	0	100	PTFE	121V5112 <sub>1</sub>	2995	481865	8	9	2.0	8116	
	5	10	0.6	-	0	2.8	2.8	0	130	PTFE	121V5112 <sub>1</sub>	4270	481000	8	8	2.0	8116	
	5	10	0.6	-	0	2.8	2.8	0	130	PTFE	121V5112 <sub>1</sub>	4270	486265	14	14	2.0	8116	
	5	10	0.6	750	0	8.5	2	0	100	Ruby	121V5163 <sub>1</sub>	2995	481865	8	9	2.0	8116	
	5	10	0.6	750	0	10	3.5	0	130	Ruby	121V5163 <sub>1</sub>	4270	481000	8	8	2.0	8116	
	5	10	0.6	750	0	14	6.5	0	140	Ruby	121V5163 <sub>1</sub>	4270	486265	14	14	2.0	8116	

#### Notes:

1. Valve only compatible with hydraulic oil and neutral liquids
2. Valve compatible with water only up to 40°C



## 2 WAY VALVES



For this page	Port size	Orifice (mm)	Kv (l/min)	MOPD (bar)	Fluid Temp (°C)	Amb Temp (°C)
From	1/4"	3	3.5	2	-20	-20
To	1/4"	5	10	22	180	50

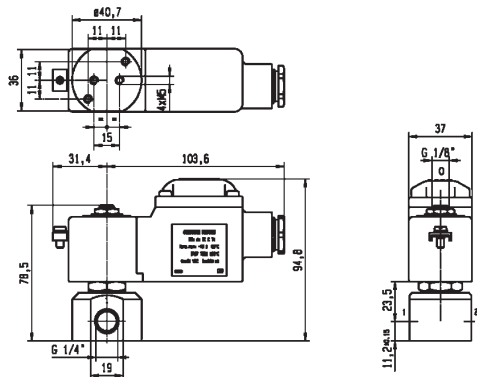

Drawing 8024

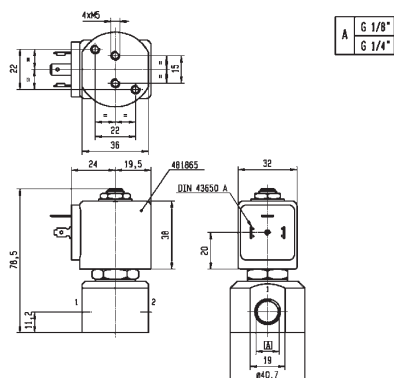

Drawing 8116

## 2 WAY VALVES

# 2/2

## HIGH CORROSION RESISTANT VALVES (303 STAINLESS STEEL) DIRECT OPERATED

303 STAINLESS ST.  
PIPE MOUNTING

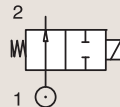

### NORMALLY OPEN

Port size	Orifice Ø	Flow factors			Operating Pressure Differential			Fluid Temp.		Seat Seal	Parker LUCIFER® Valves			Power		Coil Group	Dwg. No.
											Valve Ref.	Housing Ref.	Coil Ref.	AC W	DC W		
BSP	mm	Kv l/min	KV m³/h	Qn l/min	bar	AC bar	DC bar	°C	°C								
1/4"	2.5	3	0.18	180	0	12	12	-30	100	FKM	122V8306	2995	481865	8	9	2.1	8116
	2.5	3	0.18	180	0	12	12	-30	120	FKM	122V8306	4270	481000	8	8	2.1	8116

## 2 WAY VALVES



For this page	Port size	Orifice (mm)	Kv (l/min)	MOPD (bar)	Fluid Temp (°C)	Amb Temp (°C)
From	1/4"	2.5	3	12	-30	-10
To	1/4"	2.5	3	12	120	50

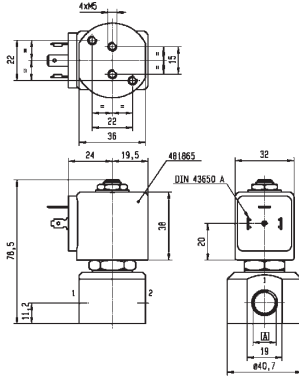

A G 1/8"  
G 1/4"



Drawing 8116

## 2 WAY VALVES

## 2 WAY VALVES



### HIGH CORROSION RESISTANT VALVES (316L STAINLESS STEEL)



# 2/2

Actuation	Body	Function	Port Size	Orifice (mm)	Flow Factor Kv(l/min)	MOPD (bar)	Max Fluid Temp. (°C)	Page Parker Valves	Page Parker LUCIFER® Valves
Direct Operated	316L Stainless St./Pipe Mounting	Normally Closed	1/4"	1.5 to 3.5	2.3	20	140	166	-
			1/8"	1.5 to 2.5	2.3	20	140	166	-
			1/2"	5 to 6.2	13	4	140	168	-
			3/8"	5 to 6.2	13	4	140	168	-
Magnalift	316L Stainless St./Pipe Mounting	Normally Closed	1/4"	1	0.6	98	75	-	170
			1/2"	15	50	10	140	172	-
			3/4"	24	95	10	140	172	-
			3/8"	15	40	10	140	172	-
			1"	24	105	10	140	174	-

## 2 WAY VALVES

# 2/2

## HIGH CORROSION RESISTANT VALVES (316L STAINLESS STEEL) DIRECT OPERATED



Commercial Equipment



Medical / Instrumentation



Industrial Equipment

### 316L STAINLESS ST. PIPE MOUNTING

#### NORMALLY CLOSED

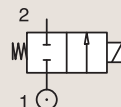

Port size	Orifice Ø	Flow factors			Operating Pressure Differential			Fluid Temp.		Seat Seal	Valve Ref.	Parker Valves		Power		Coil Group	Dwg. No.
		Kv l/min	KV m³/h	Qn l/min	Min bar	Max(MOPD) AC bar	DC bar	Min °C	Max °C			Housing Ref.	Coil Ref.	AC W	DC W		
1/8"	1.5	1	0.06	-	0	20	-	-10	140	FKM	201LG1GVG2	-	WB4.5	4.5	-	1.1/1.3	074
	1.5	1	0.06	-	0	-	10	-10	140	FKM	201LG1GVG2	-	WB5.0	-	5	1.1/1.3	074
	2	1.8	0.11	-	0	15	-	-10	140	FKM	201LG1JVG2	-	WB4.5	4.5	-	1.1/1.3	074
	2	1.8	0.11	-	0	-	7	-10	140	FKM	201LG1JVG2	-	WB5.0	-	5	1.1/1.3	074
	2.5	2.3	0.14	-	0	10	-	-10	140	FKM	201LG1LVG2	-	WB4.5	4.5	-	1.1/1.3	074
	2.5	2.3	0.14	-	0	-	4	-10	140	FKM	201LG1LVG2	-	WB5.0	-	5	1.1/1.3	074
1/4"	1.5	1	0.06	-	0	20	-	-10	140	FKM	201LG2GVG2	-	WB4.5	4.5	-	1.1/1.3	075
	1.5	1	0.06	-	0	-	10	-10	140	FKM	201LG2GVG2	-	WB5.0	-	5	1.1/1.3	075
	2	1.8	0.11	-	0	15	-	-10	140	FKM	201LG2JVG2	-	WB4.5	4.5	-	1.1/1.3	075
	2	1.8	0.11	-	0	-	7	-10	140	FKM	201LG2JVG2	-	WB5.0	-	5	1.1/1.3	075
	2.5	2.3	0.14	-	0	10	-	-10	140	FKM	201LG2LVG2	-	WB4.5	4.5	-	1.1/1.3	075
	2.5	2.3	0.14	-	0	-	4	-10	140	FKM	201LG2LVG2	-	WB5.0	-	5	1.1/1.3	075
	3	0.5	0.03	-	0	8	8	-10	140	FKM	201LG2NVG7	-	481865	8	9	2.0	076
	3	0.5	0.03	-	0	10	11	-10	140	FKM	201LG2NVG7	-	491514	13	16	2.0	076
	3.5	0.6	0.04	-	0	6	6	-10	140	FKM	201LG2PVG7	-	481865	8	9	2.0	076
	3.5	0.6	0.04	-	0	7	8	-10	140	FKM	201LG2PVG7	-	491514	13	16	2.0	076

## 2 WAY VALVES



For this page	Port size	Orifice (mm)	Kv (l/min)	MOPD (bar)	Fluid Temp (°C)	Amb Temp (°C)
From	1/8"	1.5	0.5	4	-10	-10
To	1/4"	3.5	2.3	20	140	50

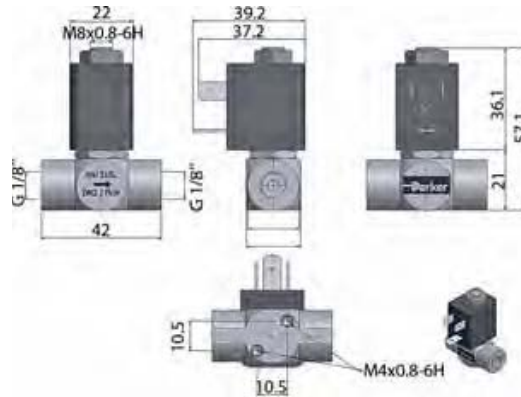

Drawing 074

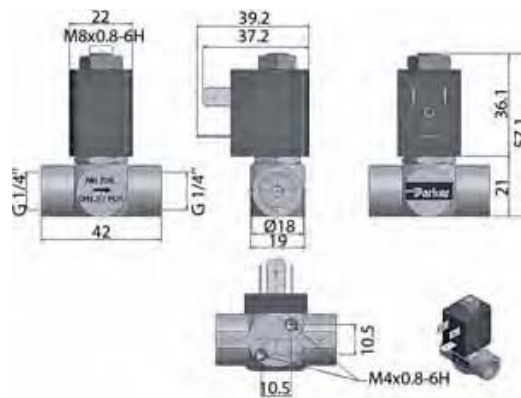

Drawing 075



Drawing 076

## 2 WAY VALVES

# 2/2

## HIGH CORROSION RESISTANT VALVES (316L STAINLESS STEEL) DIRECT OPERATED

316L STAINLESS ST.  
PIPE MOUNTING

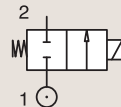

### NORMALLY CLOSED

Port size	Orifice Ø	Flow factors			Operating Pressure Differential			Fluid Temp.		Seat Seal	Parker Valves			Power		Coil Group	Dwg. No.
		Kv l/min	KV m³/h	Qn l/min	Min bar	Max(MOPD) AC bar	DC bar	Min °C	Max °C		Valve Ref.	Housing Ref.	Coil Ref.	AC W	DC W		
3/8"	5	11	0.66	-	0	3	3	-10	140	FKM	201LG3SVG7	-	481865	8	9	2.0	077
	5	11	0.66	-	0	4	4	-10	140	FKM	201LG3SVG7	-	491514	13	16	2.0	077
	6.2	13	0.78	-	0	2	2	-10	140	FKM	201LG3UVG7	-	481865	8	9	2.0	077
	6.2	13	0.78	-	0	2	3	-10	140	FKM	201LG3UVG7	-	491514	13	16	2.0	077
1/2"	5	11	0.66	-	0	3	3	-10	140	FKM	201LG4SVG7	-	481865	8	9	2.0	078
	5	11	0.66	-	0	4	4	-10	140	FKM	201LG4SVG7	-	491514	13	16	2.0	078
	6.2	13	0.78	-	0	2	2	-10	140	FKM	201LG4UVG7	-	481865	8	9	2.0	078
	6.2	13	0.78	-	0	2	3	-10	140	FKM	201LG4UVG7	-	491514	13	16	2.0	078

## 2 WAY VALVES



For this page	Port size	Orifice (mm)	Kv (l/min)	MOPD (bar)	Fluid Temp (°C)	Amb Temp (°C)
From	3/8"	5	11	2	-10	-10
To	1/2"	6.2	13	4	140	50

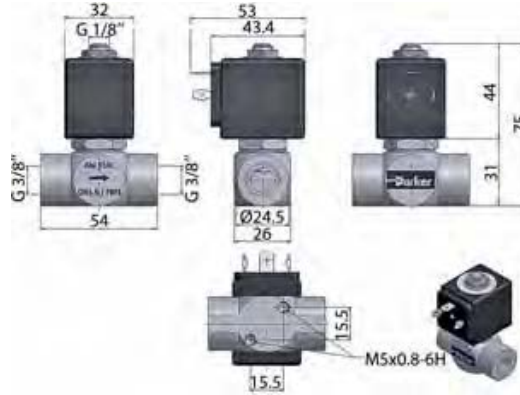

Drawing 077



Drawing 078

## 2 WAY VALVES

# 2/2

## HIGH CORROSION RESISTANT VALVES (316L STAINLESS STEEL) DIRECT OPERATED

316L STAINLESS ST.  
PIPE MOUNTING

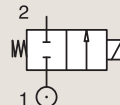

### NORMALLY CLOSED

Port size	Orifice Ø	Flow factors			Operating Pressure Differential			Fluid Temp.		Seat Seal	Parker LUCIFER® Valves			IS	Power		Coil Group	Dwg. No.
											Valve Ref.	Housing Ref.	Coil Ref.		AC W	DC W		
1/4" NPT	1	0.6	0.036	40	0	-	98	-40	75	PUR	U121V5595 <sub>1</sub>	-	492210	-	1.8	9.0/10.1	6713	
	1	0.6	0.036	40	0	-	98	-40	75	PUR	U121V5595 <sub>1</sub>	-	496565	*	-	0.3	9.0/10.1	6713
	1	0.6	0.036	40	0	98	98	-40	75	PUR	U121V5595 <sub>1</sub>	-	496800	8	8	9.0/10.1	6713	
	1	0.6	0.036	40	0	98	98	-40	75	PUR	U121V5595 <sub>1</sub>	-	496895	8	8	9.0/10.1	6713	
	1	0.6	0.036	40	0	98	98	-40	75	PUR	U121V5596 <sub>1</sub>	-	492310	6	6	10.1	6713	
	1	0.6	0.036	40	0	98	98	-40	75	PUR	U121V5596 <sub>1</sub>	-	496560	8	8	10.1	6713	
	1	0.6	0.036	40	0	98	98	-40	75	PUR	U121V5596 <sub>1</sub>	-	496800	8	8	10.1	6713	
	1	-	-	40	0	98	98	-10	75	PUR	U121V55961D <sub>1</sub>	-	483270	8	8	11.0	6714	
1	-	-	40	0	98	98	-10	75	PUR	U121V55961D <sub>1</sub>	-	483270.02	8	8	11.0	6714		

**Notes:**

1. Valve delivered with an individual material traceability certificate (3.1 following EN10204)



**2 WAY VALVES**



For this page	Port size	Orifice (mm)	Kv (l/min)	MOPD (bar)	Fluid Temp (°C)	Amb Temp (°C)
From	1/4"	1	-	98	-40	-40
To	1/4"	1	0.6	98	75	50

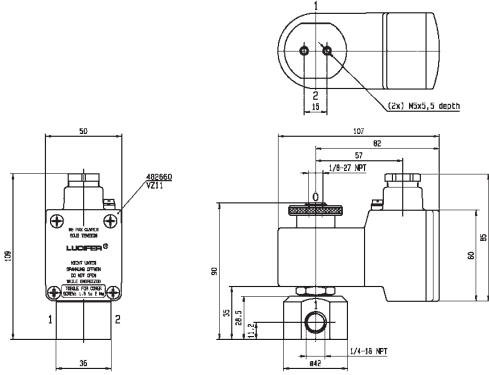

Drawing 6713

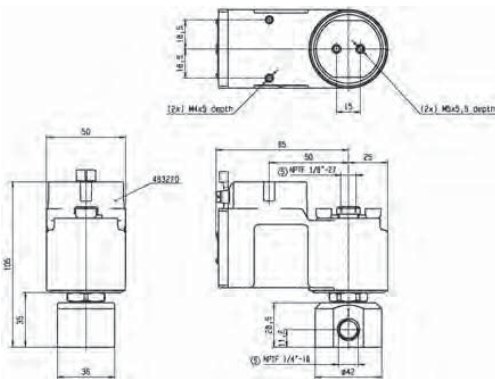

Drawing 6714



## 2 WAY VALVES

# 2/2

## HIGH CORROSION RESISTANT VALVES (316L STAINLESS STEEL) MAGNALIFT



Commercial Equipment



Medical / Instrumentation



Industrial Equipment

### 316L STAINLESS ST. PIPE MOUNTING

#### NORMALLY CLOSED

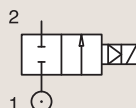

Port size	Orifice Ø	Flow factors			Operating Pressure Differential			Fluid Temp.		Seat Seal	Parker Valves			Power		Coil Group	Dwg. No.
		Kv l/min	KV m³/h	Qn l/min	Min bar	Max(MOPD) AC bar	DC bar	Min °C	Max °C		Valve Ref.	Housing Ref.	Coil Ref.	AC W	DC W		
3/8"	15	40	2.4	-	0	10	-	-10	85	EPDM	221S10E	2995	481865	8	-	2.0	067
	15	40	2.4	-	0	10	7	-10	140	EPDM	221S10E <sub>1</sub>	4270	486265	14	14	2.0	067
	15	40	2.4	-	0	10	-	-10	85	FKM	221S10F	2995	481865	8	-	2.0	067
	15	40	2.4	-	0	10	7	-10	85	FKM	221S10F <sub>1</sub>	4270	486265	14	14	2.0	067
1/2"	15	50	3	-	0	10	-	-10	85	EPDM	221S15E	2995	481865	8	-	2.0	068
	15	50	3	-	0	10	7	-10	140	EPDM	221S15E <sub>1</sub>	4270	486265	14	14	2.0	068
	15	50	3	-	0	10	-	-10	85	FKM	221S15F	2995	481865	8	-	2.0	068
	15	50	3	-	0	10	7	-10	85	FKM	221S15F <sub>1</sub>	4270	486265	14	14	2.0	068
3/4"	24	95	5.7	-	0	10	-	-10	85	EPDM	221S20E	2995	481865	8	-	2.0	069
	24	95	5.7	-	0	10	7	-10	140	EPDM	221S20E <sub>1</sub>	4270	486265	14	14	2.0	069
	24	95	5.7	-	0	10	-	-10	85	FKM	221S20F	2995	481865	8	-	2.0	069
	24	95	5.7	-	0	10	7	-10	85	FKM	221S20F <sub>1</sub>	4270	486265	14	14	2.0	069

#### Notes:

1. Maximum pressure for steam: 4 Bar (140°C)



## 2 WAY VALVES



For this page	Port size	Orifice (mm)	Kv (l/min)	MOPD (bar)	Fluid Temp (°C)	Amb Temp (°C)
From	3/8"	15	40	7	-10	-10
To	3/4"	24	95	10	140	50

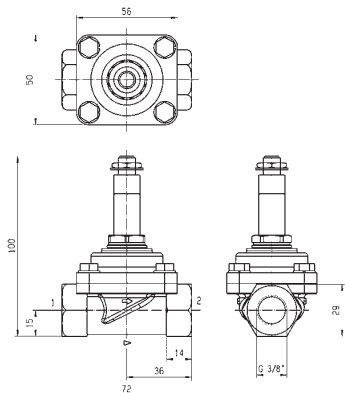

Drawing 067

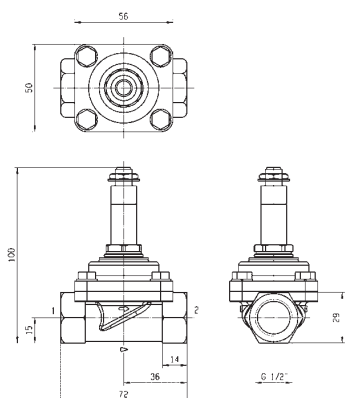

Drawing 068

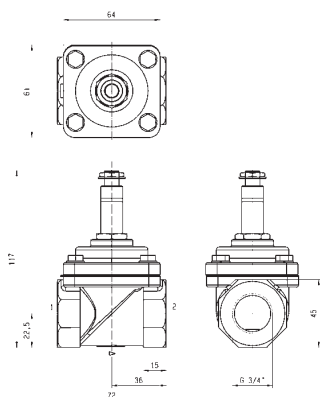

Drawing 069



## 2 WAY VALVES

# 2/2

## HIGH CORROSION RESISTANT VALVES (316L STAINLESS STEEL) MAGNALIFT

316L STAINLESS ST.  
PIPE MOUNTING

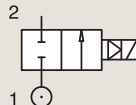

**NORMALLY CLOSED**

Port size	Orifice Ø	Flow factors			Operating Pressure Differential			Fluid Temp.		Seat Seal	Parker Valves			Power		Coil Group	Dwg. No.
		Kv	KV	Qn	Min	Max(MOPD)	Min	Max	Valve Ref.		Housing Ref.	Coil Ref.	AC W	DC W			
BSP	mm	l/min	m³/h	l/min	bar	AC bar	DC bar	°C	°C								
1"	24	105	6.3	-	0	10	-	-10	85	EPDM	221S25E	2995	481865	8	-	2.0	070
	24	105	6.3	-	0	10	7	-10	140	EPDM	221S25E <sub>1</sub>	4270	486265	14	14	2.0	070
	24	105	6.3	-	0	10	-	-10	85	FKM	221S25F	2995	481865	8	-	2.0	070
	24	105	6.3	-	0	10	7	-10	85	FKM	221S25F <sub>1</sub>	4270	486265	14	14	2.0	070

**Notes:**

1. Maximum pressure for steam: 4 Bar (140°C)

## 2 WAY VALVES



For this page	Port size	Orifice (mm)	Kv (l/min)	MOPD (bar)	Fluid Temp (°C)	Amb Temp (°C)
From	1"	24	105	7	-10	-10
To	1"	24	105	10	140	50

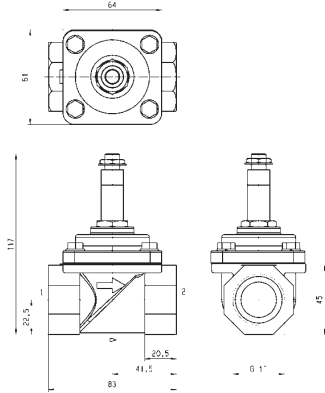

Drawing 070

## 2 WAY VALVES

## 2 WAY VALVES

### OIL BURNER VALVES



# 2/2

Actuation	Body	Function	Port Size	Orifice (mm)	Flow Factor Kv(l/min)	MOPD (bar)	Max Fluid Temp. (°C)	Page Parker Valves	Page Parker LUCIFER® Valves
Direct Operated	Brass/Pipe mounting	Normally Closed	1/8"	1.7 to 4	5.3	30	160	<b>178</b>	<b>184</b>
			1/4"	2.5 to 4	6.5	30	160	<b>180</b>	<b>184</b>
			3/8"	5 to 11	22	30	160	<b>182</b>	<b>184</b>
			1/2"	5 to 14	25	30	160	<b>182</b>	<b>184</b>
	Brass/Pipe mounting	Normally Open	1/8"	2.5 to 3	4	30	160	<b>186</b>	<b>188</b>
			1/4"	2.5 to 3	4	30	160	<b>186</b>	<b>188</b>
	Brass/Sub-base mounting	Normally Closed	14 mm	14	25	30	160	-	<b>188</b>
Magnalift	Brass/Pipe mounting	Normally Closed	1/2"	15	50	5	140	-	<b>190</b>
Pilot Operated	Brass/Pipe mounting	Normally Closed	1/4"	8	36	40	140	-	<b>192</b>
			3/8"	11	50	40	160	-	<b>192</b>
			1/2"	15	60	40	160	-	<b>194</b>
Pilot Operated	Brass/Sub-base mounting	Normally Closed	14 mm	14	45	30	160	-	<b>194</b>

## 2 WAY VALVES

# 2/2

## OIL BURNER VALVES

### DIRECT OPERATED



Heating Systems



Commercial Equipment

## BRASS PIPE MOUNTING

### NORMALLY CLOSED

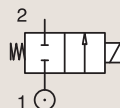

Port size	Orifice Ø	Flow factors			Operating Pressure Differential			Fluid Temp.		Seat Seal	Parker Valves			Power		Coil Group	Dwg. No.
		Kv	KV	Qn	Min	Max(MOPD)	DC	Min	Max		Valve Order Number	Valve Type	Coil Type	AC W	DC W		
BSP	mm	l/min	m <sup>3</sup> /h	m <sup>3</sup> /h	bar	AC bar	DC bar	°C	°C								
1/8"	1.7	1.4	0.086	-	0	25	-	-10	90	NBR	390034 <sub>2</sub>	131IN	KT09 110-120/60	9	-	22.0	015
	1.7	1.4	0.086	-	0	25	-	-10	90	NBR	390085 <sub>2</sub>	131IN	KT09 208-230/60	9	-	22.0	015
	1.7	1.4	0.086	-	0	25	-	-10	90	NBR	390005 <sub>2</sub>	131IN	KT09 24/50	9	-	22.0	015
	1.7	1.4	0.086	-	0	-	22	-10	90	NBR	390120 <sub>2</sub>	131IN	KT10 24 DC	-	10	22.0	015
	1.7	1.4	0.086	-	0	25	-	-10	90	NBR	390300 <sub>12</sub>	131INDIN	XT09 230/50	9	-	22.0	015
	1.7	1.4	0.086	-	0	25	-	-10	90	FKM	390086 <sub>2</sub>	131IV	KT09 208-230/60	9	-	22.0	015
	1.7	1.4	0.086	-	0	25	-	-10	90	FKM	390088 <sub>12</sub>	131IV	KT09 230/50	9	-	22.0	015
	1.7	1.4	0.086	-	0	25	-	-10	90	FKM	390089 <sub>2</sub>	131IV	KT09 240/50	9	-	22.0	015
	2.2	2	0.12	-	0	15	-	-10	90	NBR	390216 <sub>2</sub>	131AN	KT09 208-230/60	9	-	22.0	015
	2.2	2	0.12	-	0	15	-	-10	90	NBR	390165 <sub>2</sub>	131AN	KT09 230/50	9	-	22.0	015
	2.2	2	0.12	-	0	15	-	-10	90	NBR	390145 <sub>2</sub>	131AN	KT09 24/50	9	-	22.0	015
	2.2	2	0.12	-	0	15	-	-10	90	NBR	390150 <sub>2</sub>	131AN	KT09 42/50	9	-	22.0	015
	2.2	2	0.12	-	0	-	13	-10	90	NBR	390195 <sub>2</sub>	131AN	KT10 12 DC	-	10	22.0	015
	2.2	2	0.12	-	0	-	13	-10	90	NBR	390215 <sub>2</sub>	131AN	KT10 24 DC	-	10	22.0	015
	2.5	3.2	0.192	-	0	30	-	-30	140	Ruby	362496J	PM140IR	ZB09	9	-	20.1/20.2	027
	2.5	3.2	0.192	-	0	-	17	-30	140	Ruby	362496J	PM140IR	ZB12	-	12	20.1/20.2	027
	2.8	2.9	0.174	-	0	8	-	-10	140	FKM	390445 <sub>2</sub>	131.4BV	KT09 115/50	9	-	22.0	012
	2.8	2.9	0.174	-	0	8	-	-10	140	FKM	390457 <sub>2</sub>	131.4BV	KT09 115/60	9	-	22.0	012
	2.8	2.9	0.174	-	0	8	-	-10	140	FKM	390458 <sub>2</sub>	131.4BV	KT09 208-230/60	9	-	22.0	012
	2.8	2.9	0.174	-	0	8	-	-10	140	FKM	390465 <sub>2</sub>	131.4BV	KT09 230/50	9	-	22.0	012
2.8	2.9	0.174	-	0	8	-	-10	140	FKM	390405 <sub>2</sub>	131.4BV	KT09 24/50	9	-	22.0	012	
2.8	2.9	0.174	-	0	-	6	-10	140	FKM	390495 <sub>2</sub>	131.4BV	KT10 12 DC	-	10	22.0	012	
2.8	2.9	0.174	-	0	-	6	-10	140	FKM	390505 <sub>2</sub>	131.4BV	KT10 24 DC	-	10	22.0	012	

#### Notes:

- DIN-EN-ISO 23553-1 (2009-10) approved for oil burners
- Ordering number is for an assembled valve and coil, with the voltage shown.



## 2 WAY VALVES



For this page	Port size	Orifice (mm)	Kv (l/min)	MOPD (bar)	Fluid Temp (°C)	Amb Temp (°C)
From	1/8"	1.7	1.4	6	-30	-10
To	1/8"	2.8	3.2	30	140	50

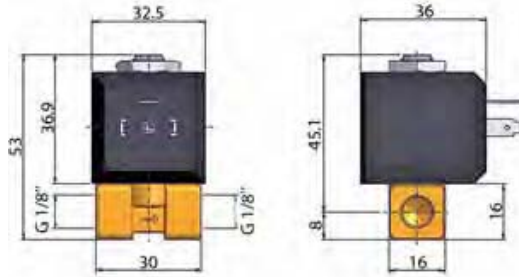

Drawing 015

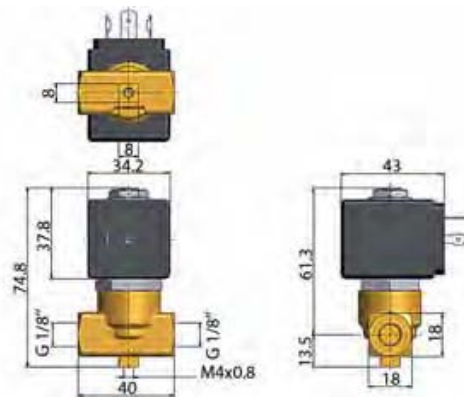

Drawing 027

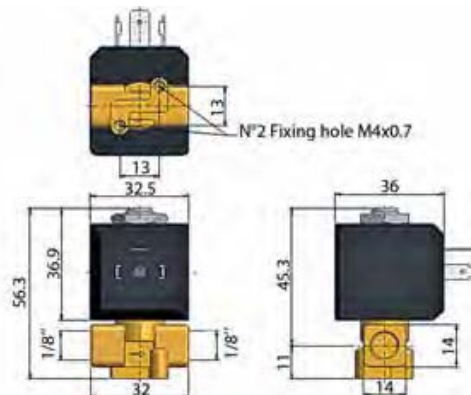

Drawing 012

## 2 WAY VALVES

# 2/2

## OIL BURNER VALVES DIRECT OPERATED

BRASS  
PIPE MOUNTING  
NORMALLY CLOSED

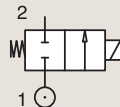

Port size	Orifice Ø	Flow factors			Operating Pressure Differential			Fluid Temp.		Seat Seal	Valve Order Number	Parker Valves		Power		Coil Group	Dwg. No.
		Kv l/min	KV m³/h	Qn m³/h	Min bar	Max(MOPD) AC bar	DC bar	Min °C	Max °C			Valve Type	Coil Type	AC W	DC W		
1/8"	3	4	0.24	-	0	30	-	-30	140	Ruby	362510J <sub>1</sub>	PM140.4AR	ZH14	14	-	20.2	025
	4	5.3	0.318	-	0	2	-	-10	90	NBR	390874 <sub>2</sub>	131.4CG	KT09 115/50	9	-	22.0	013
	4	5.3	0.318	-	0	2	-	-10	90	NBR	390813 <sub>2</sub>	131.4CG	KT09 115/60	9	-	22.0	013
	4	5.3	0.318	-	0	2	-	-10	90	NBR	390878 <sub>2</sub>	131.4CG	KT09 230/50	9	-	22.0	013
	4	5.3	0.318	-	0	2	-	-10	90	NBR	390805 <sub>2</sub>	131.4CG	KT09 24/50	9	-	22.0	013
	4	5.3	0.318	-	0	2	-	-10	90	NBR	390875 <sub>2</sub>	131.4CG	KT09 240/50	9	-	22.0	013
	4	5.3	0.318	-	0	-	1	-10	90	NBR	390803 <sub>2</sub>	131.4CG	KT10 12DC	-	10	22.0	013
	4	5.3	0.318	-	0	-	1	-10	90	NBR	390802 <sub>2</sub>	131.4CG	KT10 24 DC	-	10	22.0	013
1/4"	2.5	3.2	0.192	-	0	30	-	-30	140	Ruby	362518J <sub>1</sub>	PM140CR	ZB09	9	-	20.1/20.2	026
	2.5	3.2	0.192	-	0	-	17	-30	140	Ruby	362518J <sub>1</sub>	PM140CR	ZB12	-	12	20.1/20.2	026
	2.5	3.2	0.192	-	0	30	-	-30	140	Ruby	362518J <sub>1</sub>	PM140CR	ZH14	14	-	20.1/20.2	026
	2.5	3.2	0.192	-	0	-	17	-30	140	Ruby	362518J <sub>1</sub>	PM140CR	ZH16	-	16	20.1/20.2	026
	2.8	2.9	0.174	-	0	8	-	-10	140	FKM	390560 <sub>2</sub>	131.4FV	KT09 115/50	9	-	22.0	014
	2.8	2.9	0.174	-	0	8	-	-10	140	FKM	390560 <sub>2</sub>	131.4FV	KT09 115/60	9	-	22.0	014
	2.8	2.9	0.174	-	0	8	-	-10	140	FKM	390626 <sub>2</sub>	131.4FV	KT09 208-230/60	9	-	22.0	014
	2.8	2.9	0.174	-	0	8	-	-10	140	FKM	390580 <sub>2</sub>	131.4FV	KT09 230/50	9	-	22.0	014
	2.8	2.9	0.174	-	0	8	-	-10	140	FKM	390525 <sub>2</sub>	131.4FV	KT09 24/50	9	-	22.0	014
	2.8	2.9	0.174	-	0	-	6	-10	140	FKM	390605 <sub>2</sub>	131.4FV	KT10 12 DC	-	10	22.0	014
	2.8	2.9	0.174	-	0	-	6	-10	140	FKM	390625 <sub>2</sub>	131.4FV	KT10 24 DC	-	10	22.0	014
	3	4	0.24	-	0	30	-	-30	140	Ruby	362530J <sub>1</sub>	PM140.4DR	ZH14	14	-	20.0/20.1/20.2	026
	3	4	0.24	-	0	30	-	-30	140	Ruby	362524J	PM140DR	ZB09	9	-	20.1/20.2	026
	3	4	0.24	-	0	-	12	-30	140	Ruby	362524J	PM140DR	ZB12	-	12	20.1/20.2	026
3	4	0.24	-	0	30	-	-30	140	Ruby	362524J	PM140DR	ZH14	14	-	20.1/20.2	026	
3	4	0.24	-	0	-	12	-30	140	Ruby	362524J	PM140DR	ZH16	-	16	20.1/20.2	026	
4	5.3	0.318	-	0	1	-	-10	90	NBR	390915 <sub>2</sub>	131.4GG	KT09 115/50	9	-	22.0	013	
4	5.3	0.318	-	0	1	-	-10	90	NBR	390945 <sub>2</sub>	131.4GG	KT09 230/50	9	-	22.0	013	
4	5.3	0.318	-	0	1	-	-10	90	NBR	390895 <sub>2</sub>	131.4GG	KT09 24/50	9	-	22.0	013	
4	5.3	0.318	-	0	1	-	-10	90	NBR	390975 <sub>2</sub>	131.4GG	KT09 240/50	9	-	22.0	013	
4	5.3	0.318	-	0	-	1	-10	90	NBR	390995 <sub>2</sub>	131.4GG	KT10 12 DC	-	10	22.0	013	
4	5.3	0.318	-	0	-	1	-10	90	NBR	390997 <sub>2</sub>	131.4GG	KT10 24 DC	-	10	22.0	013	
4	5.3	0.318	-	0	2	-	-10	140	FKM	390668 <sub>2</sub>	131.4GV	KT09 115/50	9	-	22.0	014	
4	5.3	0.318	-	0	2	-	-10	140	FKM	390700 <sub>2</sub>	131.4GV	KT09 115/60	9	-	22.0	014	
4	5.3	0.318	-	1	2	-	-10	140	FKM	390725 <sub>2</sub>	131.4GV	KT09 208-230/60	9	-	22.0	014	

### Notes:

- DIN-EN-ISO 23553-1 (2009-10) approved for oil burners
- Ordering number is for an assembled valve and coil, with the voltage shown.



## 2 WAY VALVES



For this page	Port size	Orifice (mm)	Kv (l/min)	MOPD (bar)	Fluid Temp (°C)	Amb Temp (°C)
From	1/8"	2.5	2.9	1	-30	-10
To	1/4"	4	5.3	30	140	50

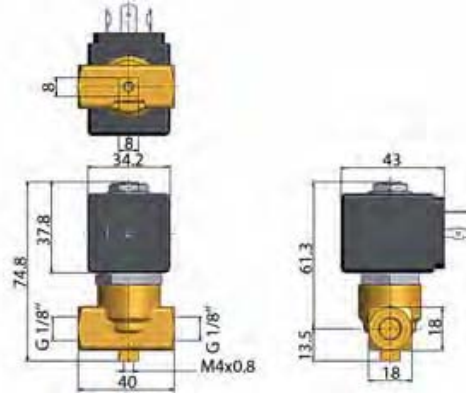

Drawing 025

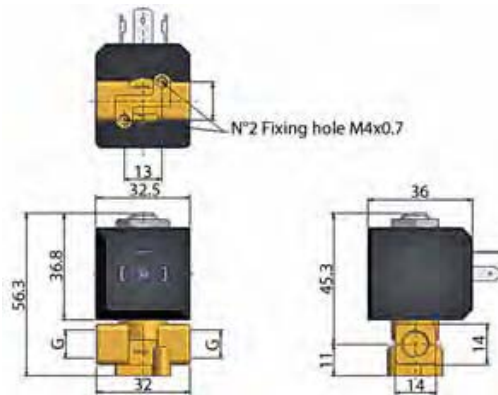

Drawing 013

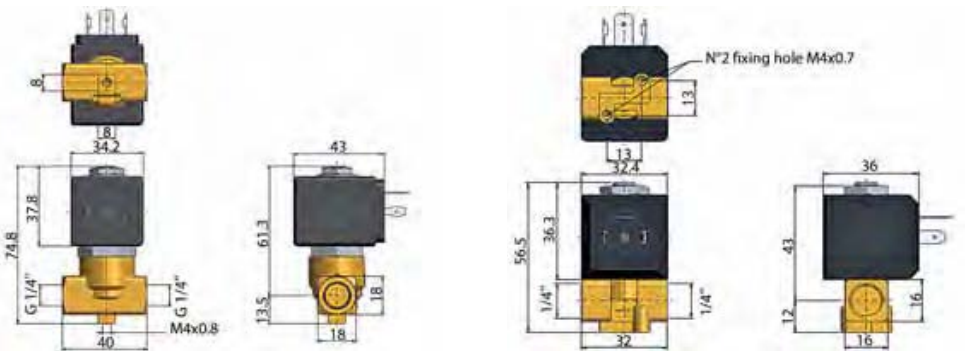

Drawing 026

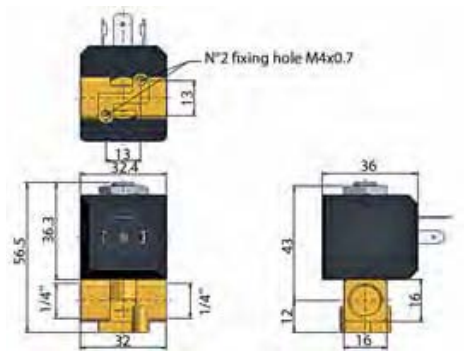

Drawing 014

## 2 WAY VALVES

# 2/2

## OIL BURNER VALVES

### DIRECT OPERATED

BRASS

PIPE MOUNTING

**NORMALLY CLOSED**

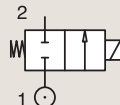

Port size	Orifice Ø	Flow factors			Operating Pressure Differential			Fluid Temp.		Seat Seal	Valve Order Number	Parker Valves		Power		Coil Group	Dwg. No.
		Kv l/min	KV m <sup>3</sup> /h	Qn m <sup>3</sup> /h	Min bar	Max(MOPD) DC bar	Min °C	Max °C	Valve Type			Coil Type	AC W	DC W			
1/4"	4	5.3	0.318	-	0	2	-	-10	140	FKM	390705 <sub>1</sub>	131.4GV	KT09 230/50	9	-	22.0	014
	4	5.3	0.318	-	0	2	-	-10	140	FKM	390650 <sub>1</sub>	131.4GV	KT09 24/50	9	-	22.0	014
	4	5.3	0.318	-	0	2	-	-10	140	FKM	390718 <sub>1</sub>	131.4GV	KT09 240/50	9	-	22.0	014
	4	5.3	0.318	-	0	-	1	-10	140	FKM	390720 <sub>1</sub>	131.4GV	KT10 12 DC	-	10	22.0	014
	4	5.3	0.318	-	0	-	1	-10	140	FKM	390721 <sub>1</sub>	131.4GV	KT10 24 DC	-	10	22.0	014
3/8"	5	10	0.612	-	0	5	-	-10	140	FKM	364010	PM153BV	ZB14	14	-	20.2/22.0	037
	5	10	0.612	-	0	-	1.5	-10	140	FKM	364010	PM153BV	ZB16	-	16	20.2/22.0	037
1/2"	5	10	0.612	-	0	5	-	-10	140	FKM	364035	PM153GV	ZB14	14	-	20.2/22.0	037
	5	10	0.612	-	0	-	1.5	-10	140	FKM	364035	PM153GV	ZB16	-	16	20.2/22.0	037

**Notes:**

1. Ordering number is for an assembled valve and coil, with the voltage shown.



## 2 WAY VALVES



For this page	Port size	Orifice (mm)	Kv (l/min)	MOPD (bar)	Fluid Temp (°C)	Amb Temp (°C)
From	1/4"	4	5.3	1	-10	-10
To	1/2"	5	10	5	140	50

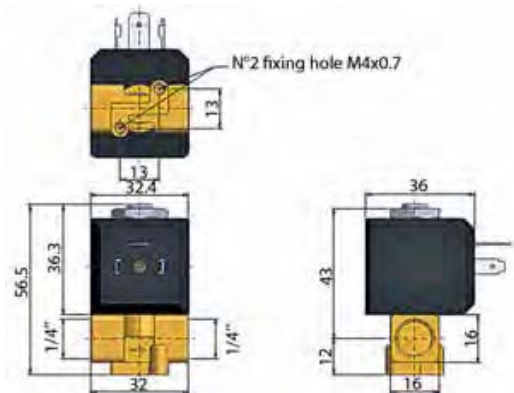

Drawing 014

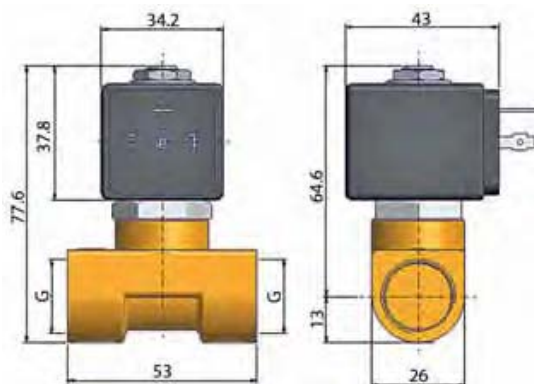

Drawing 037

## 2 WAY VALVES

# 2/2

## OIL BURNER VALVES

### DIRECT OPERATED

BRASS

PIPE MOUNTING

**NORMALLY CLOSED**

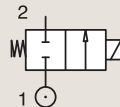

Port size	Orifice Ø	Flow factors			Operating Pressure Differential			Fluid Temp.		Seat Seal	Parker LUCIFER® Valves			Power		Coil Group	Dwg. No.
					Min	Max(MOPD)	DC	Min	Max		Valve Ref.	Housing Ref.	Coil Ref.	AC W	DC W		
					bar	AC bar	DC bar	°C	°C								
1/8"	3	4	0.24	-	0	30	-	-30	160	Ruby	121K2423 <sup>13</sup>	8520.23	483824	19	-	14.1	3292
	3	4.5	0.27	-	0	30	-	-30	160	Ruby	121K6423 <sup>13</sup>	8520.23	483824	19	-	14.1	3292
1/4"	4	6.5	0.39	-	0	30	-	0	160	Ruby	121K6220 <sup>13</sup>	8520.23	483541	20	-	14.3	3510
	6	12	0.72	0	0	5	-	0	120	Ruby	121K3321	2995	492425	14	-	14.1	3551
3/8"	11	22	1.32	-	0	30	-	0	160	FKM	121G2320 <sup>123</sup>	8520.23	483541	20	-	14.3	3646
	14	25	1.5	-	0	30	-	0	160	FKM	121G2520 <sup>123</sup>	8520.23	483541	20	-	14.3	3646
1/2"	14	25	1.5	-	0	30	-	0	160	FKM	121G2523 <sup>123</sup>	8520.23	483824	19	-	14.1	3646

**Notes:**

1. DIN-EN-ISO 23553-1 (2009-10) approved for oil burners
2. Max. Static pressure = 30 bar; max pressure differential = 0.2 bar
3. Valve only compatible with hydraulic oil and neutral liquids

Valve	A
121803	ø 3/8"
121805	ø 1/2"

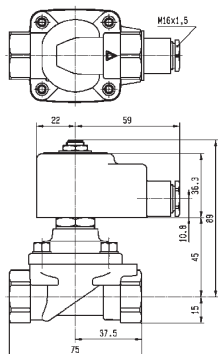
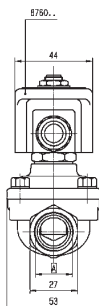

Drawing 3646



## 2 WAY VALVES



For this page	Port size	Orifice (mm)	Kv (l/min)	MOPD (bar)	Fluid Temp (°C)	Amb Temp (°C)
From	1/8"	3	4	5	-30	0
To	1/2"	14	25	30	160	60

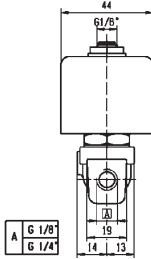
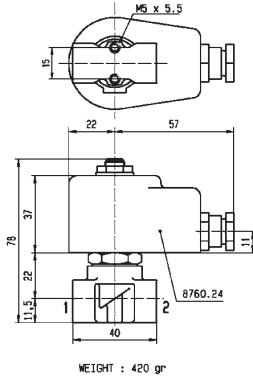

Drawing 3292

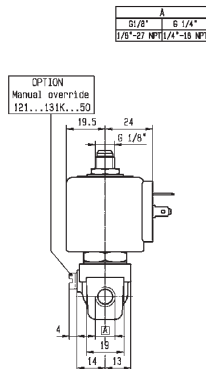
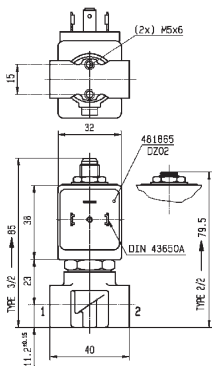

Drawing 3510

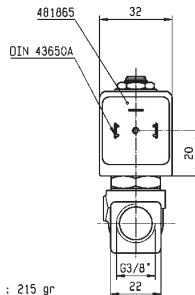
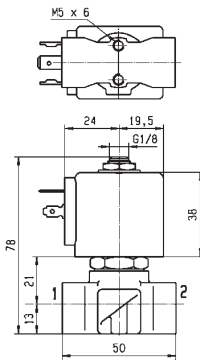

WEIGHT: 215 gr



Drawing 3551



## 2 WAY VALVES

# 2/2

## OIL BURNER VALVES

### DIRECT OPERATED

BRASS

PIPE MOUNTING

**NORMALLY OPEN**

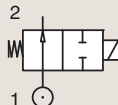

Port size	Orifice Ø	Flow factors			Operating Pressure Differential			Fluid Temp.		Seat Seal	Parker Valves			Power		Coil Group	Dwg. No.
		Kv	KV	Qn	Min	Max(MOPD)	DC	Min	Max		Valve Order Number	Valve Type	Coil Type	AC W	DC W		
BSP	mm	l/min	m <sup>3</sup> /h	m <sup>3</sup> /h	bar	AC bar	DC bar	°C	°C								
1/8"	3	4	0.24	-	0	30	-	-30	160	Ruby	360451J	PM120.4IR	ZB14	14	-	20.2	001
	3	4	0.24	-	0	30	-	-30	160	Ruby	360451J <sub>1</sub>	PM120.4IR	ZH14	14	-	20.2	001
1/4"	3	4	0.24	-	0	30	-	-30	160	Ruby	360452J	PM120.4AR	ZB14	14	-	20.2	001
	3	4	0.24	-	0	30	-	-30	160	Ruby	360452J <sub>1</sub>	PM120.4AR	ZH14	14	-	20.2	001

**Notes:**

1. DIN-EN-ISO 23553-1 (2009-10) approved for oil burners

## 2 WAY VALVES



For this page	Port size	Orifice (mm)	Kv (l/min)	MOPD (bar)	Fluid Temp (°C)	Amb Temp (°C)
From	1/8"	3	4	30	-30	-10
To	1/4"	3	4	30	160	50

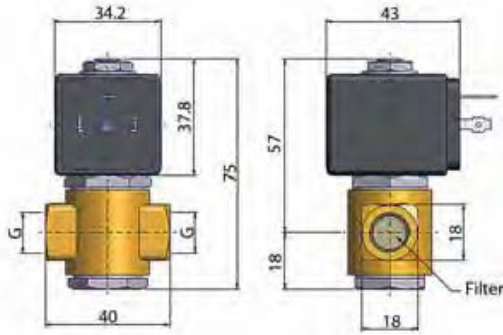

Drawing 001

## 2 WAY VALVES

# 2/2

## OIL BURNER VALVES DIRECT OPERATED

### BRASS PIPE MOUNTING

#### NORMALLY OPEN

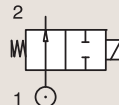

Port size	Orifice Ø	Flow factors			Operating Pressure Differential			Fluid Temp.		Seat Seal	Parker LUCIFER® Valves			Power		Coil Group	Dwg. No.
					Min	Max(MOPD)		Min	Max		Valve Ref.	Housing Ref.	Coil Ref.	AC W	DC W		
					bar	AC bar	DC bar	°C	°C								
BSP	mm	Kv l/min	KV m³/h	Qn l/min	bar	AC bar	DC bar	°C	°C								
1/8"	2.5	3.5	0.21	-	0	30	-	-30	160	Ruby	122K9321 <sub>1</sub>	8520.23	483824	19	-	14.1	6766
1/4"	2.5	3.5	0.21	-	0	30	-	-30	160	Ruby	122K8321 <sub>1</sub>	8520.23	483824	19	-	14.1	6766

#### Notes:

1. DIN-EN-ISO 23553-1 (2009-10) approved for oil burners

### BRASS SUB-BASE MOUNTING

#### NORMALLY CLOSED

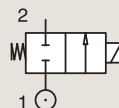

Port size	Orifice Ø	Flow factors			Operating Pressure Differential			Fluid Temp.		Seat Seal	Parker LUCIFER® Valves			Power		Coil Group	Dwg. No.
					Min	Max(MOPD)		Min	Max		Valve Ref.	Housing Ref.	Coil Ref.	AC W	DC W		
					bar	AC bar	DC bar	°C	°C								
SB	14	25	1.5	-	0	30	-	0	160	FKM	121F2523 <sub>1</sub>	8520.23	483824	19	-	14.1	7638

#### Notes:

1. DIN-EN-ISO 23553-1 (2009-10) approved for oil burners

## 2 WAY VALVES



For this page	Port size	Orifice (mm)	Kv (l/min)	MOPD (bar)	Fluid Temp (°C)	Amb Temp (°C)
From	1/8"	2.5	3.5	30	-30	0
To	14 mm	14	25	30	160	60

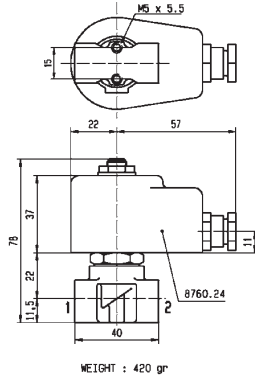

A G 1/8"  
G 1/4"

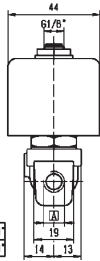

Drawing 6766

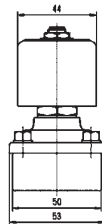
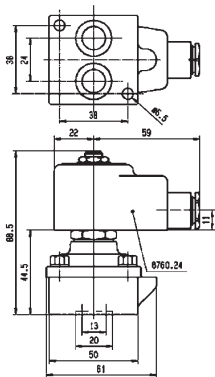

Drawing 7638

## 2 WAY VALVES

# 2/2

## OIL BURNER VALVES

### MAGNALIFT



Heating Systems

BRASS  
PIPE MOUNTING

**NORMALLY CLOSED**

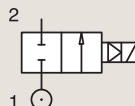

Port size	Orifice Ø	Flow factors			Operating Pressure Differential			Fluid Temp.		Seat Seal	Parker LUCIFER® Valves			Power		Coil Group	Dwg. No.
		Kv l/min	KV m³/h	Qn l/min	Min bar	Max(MOPD) AC bar	DC bar	Min °C	Max °C		Valve Ref.	Housing Ref.	Coil Ref.	AC W	DC W		
1/2"	15	50	3	0	0	5	-	0	140	FKM	221G2523 <sub>1</sub>	8520.25	483824	19	-	14.1	8298

**Notes:**

1. DIN-EN-ISO 23553-1 (2009-10) approved for oil burners

## 2 WAY VALVES



For this page	Port size	Orifice (mm)	Kv (l/min)	MOPD (bar)	Fluid Temp (°C)	Amb Temp (°C)
From	1/2"	15	50	5	0	0
To	1/2"	15	50	5	140	60

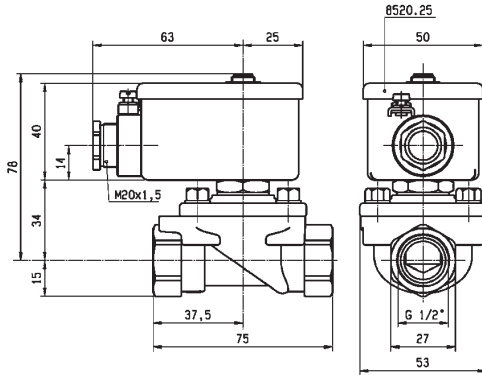

Drawing 8298

## 2 WAY VALVES

# 2/2

## OIL BURNER VALVES

### PILOT OPERATED



Commercial Equipment



Industrial Equipment



Heating Systems

### BRASS

### PIPE MOUNTING

### NORMALLY CLOSED

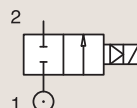

Port size	Orifice Ø	Flow factors			Operating Pressure Differential			Fluid Temp.		Seat Seal	Parker LUCIFER® Valves			Power		Coil Group	Dwg. No.
											Valve Ref.	Housing Ref.	Coil Ref.	AC W	DC W		
BSP	mm	Kv l/min	KV m³/h	Qn l/min	Min bar	Max(MOPD) AC bar	DC bar	Min °C	Max °C								
1/4"	8	36	2.16	-	0.3	40	25	-10	100	FKM	E321H21 <sup>234</sup>	2995	481865	8	9	2.0	3523
	8	36	2.16	-	0.3	40	30	-10	120	FKM	E321H21 <sup>234</sup>	4270	481000	8	8	2.0	3523
	8	36	2.16	-	0.3	40	40	-10	140	FKM	E321H21 <sup>234</sup>	4270	486265	14	14	2.0	3523
3/8"	11	40	2.4	-	0.3	30	-	0	160	Ruby	321H2322 <sup>124</sup>	8520.23	483541	20	-	14.3	3633
	11	50	3	-	0.3	40	25	-10	100	FKM	E321H23 <sup>234</sup>	2995	481865	8	9	2.0	3521
	11	50	3	-	0.3	40	30	-10	120	FKM	E321H23 <sup>234</sup>	4270	481000	8	8	2.0	3521
	11	50	3	-	0.3	40	40	-10	140	FKM	E321H23 <sup>234</sup>	4270	486265	14	14	2.0	3521

#### Notes:

1. DIN-EN-ISO 23553-1 (2009-10) approved for oil burners
2. Minimum pressure differential = 0.3 bar for opening and 0 bar for closing
3. Pilot seat disc in synthetic Ruby
4. Valve only compatible with hydraulic oil and neutral liquids



## 2 WAY VALVES



For this page	Port size	Orifice (mm)	Kv (l/min)	MOPD (bar)	Fluid Temp (°C)	Amb Temp (°C)
From	1/4"	8	36	25	-10	-10
To	3/8"	11	50	40	160	50

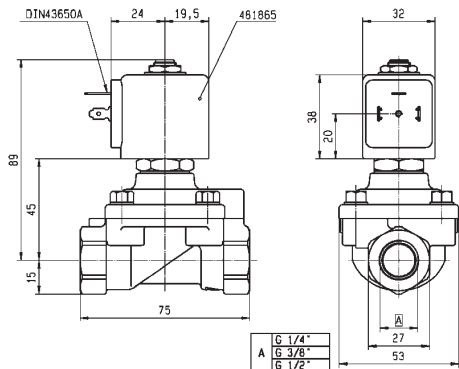

Drawing 3523

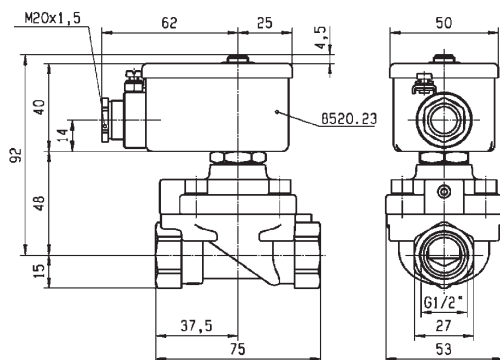

Drawing 3633

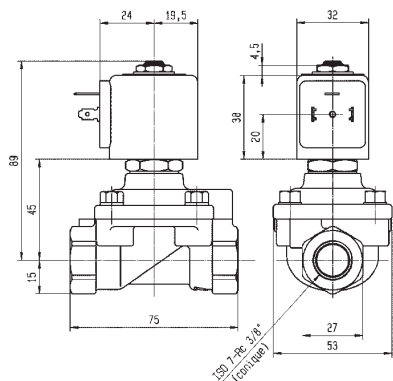

Drawing 3521

## 2 WAY VALVES

# 2/2

## OIL BURNER VALVES PILOT OPERATED

### BRASS

### PIPE MOUNTING

#### NORMALLY CLOSED

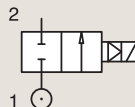

Port size	Orifice Ø	Flow factors			Operating Pressure Differential			Fluid Temp.		Seat Seal	Parker LUCIFER® Valves			Power		Coil Group	Dwg. No.
					Min	Max(MOPD)					Valve Ref.	Housing Ref.	Coil Ref.	AC W	DC W		
					bar	AC bar	DC bar										
1/2"	15	60	3.6	-	0.3	30	-	0	160	Ruby	321H2522 <sup>14</sup>	8520.23	483541	20	-	14.3	3633
	15	60	3.6	-	0.3	30	-	0	160	Ruby	321H2523 <sup>14</sup>	8520.23	483824	19	-	14.1	3633
	15	60	3.6	-	0.3	40	25	-10	100	FKM	E321H25 <sup>234</sup>	2995	481865	8	9	2.0/14.2	3522
	15	60	3.6	-	0.3	40	30	-10	120	FKM	E321H25 <sup>234</sup>	-	483371	8	8	2.0/14.2	3522
	15	60	3.6	-	0.3	40	40	-10	140	FKM	E321H25 <sup>234</sup>	4270	486265	14	14	2.0/14.2	3522

#### Notes:

1. DIN-EN-ISO 23553-1 (2009-10) approved for oil burners
2. Minimum pressure differential = 0.3 bar for opening and 0 bar for closing
3. Pilot seat disc in synthetic Ruby
4. Valve only compatible with hydraulic oil and neutral liquids

### BRASS

### SUB-BASE MOUNTING

#### NORMALLY CLOSED

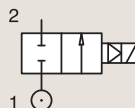

Port size	Orifice Ø	Flow factors			Operating Pressure Differential			Fluid Temp.		Seat Seal	Parker LUCIFER® Valves			Power		Coil Group	Dwg. No.
					Min	Max(MOPD)					Valve Ref.	Housing Ref.	Coil Ref.	AC W	DC W		
					bar	AC bar	DC bar										
SB	14	45	2.7	-	0	30	-	0	160	FKM	321F2523 <sup>12</sup>	8520.23	483824	19	-	14.1	7639

#### Notes:

1. DIN-EN-ISO 23553-1 (2009-10) approved for oil burners
2. Minimum pressure differential = 0.3 bar for opening and 0 bar for closing

## 2 WAY VALVES



For this page	Port size	Orifice (mm)	Kv (l/min)	MOPD (bar)	Fluid Temp (°C)	Amb Temp (°C)
From	1/2"	14	45	25	-10	-10
To	14 mm	15	60	40	160	50

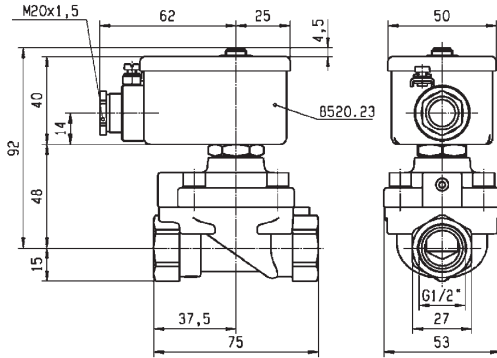

Drawing 3633

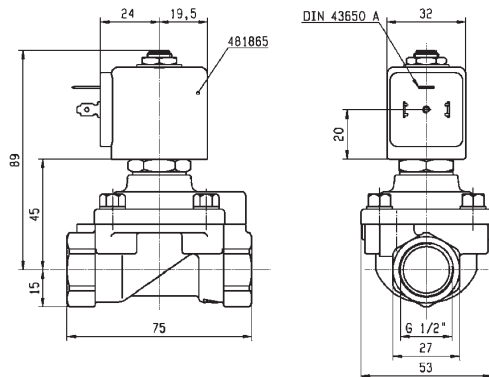

Drawing 3522

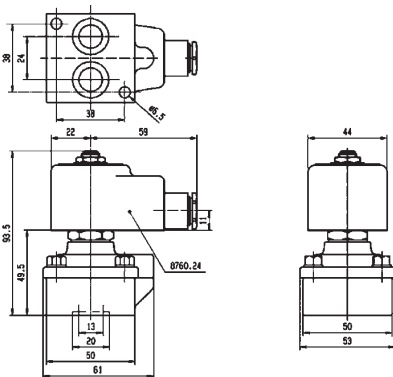

Drawing 7639



## 2 WAY VALVES

## 2 WAY VALVES

### FAST SWITCHING VALVES



# 2/2

Actuation	Body	Function	Port Size	Orifice (mm)	Flow Factor Kv(l/min)	MOPD (bar)	Max Fluid Temp. (°C)	Page Parker Valves	Page Parker LUCIFER® Valves
Magnalift	Brass/Pipe mounting	Normally Closed	3/8"	8	0	7	40	-	198

## 2 WAY VALVES

# 2/2

## FAST SWITCHING VALVES

### MAGNALIFT



Industrial Equipment

### BRASS PIPE MOUNTING

#### NORMALLY CLOSED

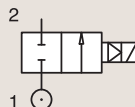

Port size	Orifice Ø mm	Flow factors			Operating Pressure Differential			Fluid Temp.		Seat Seal	Parker LUCIFER® Valves			Power		Coil Group	Dwg. No.
		Kv l/min	KV m³/h	Qn l/min	Min bar	Max(MOPD) AC bar	DC bar	Min °C	Max °C		Valve Ref.	Housing Ref.	Coil Ref.	AC W	DC W		
3/8"	8	-	-	-	0	-	7	0	40	PUR	221J3301E <sub>1</sub>	2995.6	483816	-	14		8020

**Notes:**

1. For more details, please consult catalogue 8674UK

Flow rate (valve on 100%)

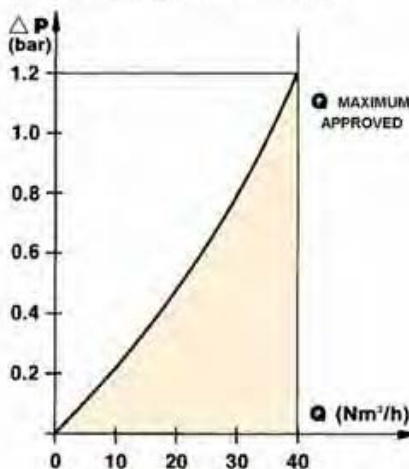

## 2 WAY VALVES



For this page	Port size	Orifice (mm)	Kv (l/min)	MOPD (bar)	Fluid Temp (°C)	Amb Temp (°C)
From	3/8"	8	-	7	0	0
To	3/8"	8	-	7	40	50

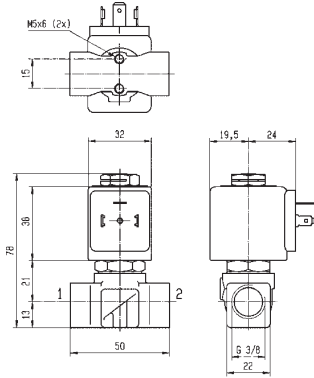

Drawing 8020

## 2 WAY VALVES

## 2 WAY VALVES



### VALVES FOR BEVERAGE DISPENSING - LIQUIPURE®



# 2/2

Actuation	Body	Function	Port Size	Orifice (mm)	Flow Factor Kv(l/min)	MOPD (bar)	Max Fluid Temp. (°C)	Page Parker Valves
Direct Operated	Stainless St./Sub-base mounting	Normally Closed	SB	1.5 to 3	4.2	20	-	202

## 2 WAY VALVES

# 2/2

## VALVES FOR BEVERAGE DISPENSING - LIQUIPURE® DIRECT OPERATED



Beverage Dispensing



Medical / Instrumentation

### STAINLESS ST. SUB-BASE MOUNTING

#### NORMALLY CLOSED

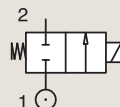

Port size	Orifice Ø mm	Flow factors			Operating Pressure Differential			Fluid Temp.		Seat Seal	Valve Ref.	Parker Valves		Power		Coil Group	Dwg. No.
		Kv l/min	KV m³/h	Qn l/min	Min bar	Max(MOPD) AC bar	DC bar	Min °C	Max °C			Housing Ref.	Coil Ref.	AC W	DC W		
SB	1.5	1.3	0.08	-	0	20	20	-10	140	Ruby	2019F1GRG7	-	D4	13	16	24.0	071
	1.5	1.3	0.08	-	0	20	20	-10	140	Ruby	2019F1GRG7	-	D5	8	9	24.0	071
	1.5	1.3	0.08	-	0	20	20	-10	140	Ruby	2019F1GRG7	-	LA	9	9	24.0	071
	1.5	1.3	0.08	-	0	20	20	-10	140	Ruby	2019F1GRG7	-	LB-LC	13	16	24.0	071
	1.5	1.3	0.08	-	0	20	-	-10	140	Ruby	2019F1GRG7	-	XS03	9	-	24.0	071
	1.5	1.3	0.08	-	0	20	20	-10	140	FDA FKM	2019F1GVG7	-	D4	13	16	24.0	071
	1.5	1.3	0.08	-	0	20	20	-10	140	FDA FKM	2019F1GVG7	-	D5	8	9	24.0	071
	1.5	1.3	0.08	-	0	20	20	-10	140	FDA FKM	2019F1GVG7	-	LA	9	9	24.0	071
	1.5	1.3	0.08	-	0	20	20	-10	140	FDA FKM	2019F1GVG7	-	LB-LC	13	16	24.0	071
	1.5	1.3	0.08	-	0	20	-	-10	140	FDA FKM	2019F1GVG7	-	XS03	9	-	24.0	071
	2	2.3	0.14	-	0	15	15	-10	140	Ruby	2019F1JRG7	-	D4	13	16	24.0	071
	2	2.3	0.14	-	0	15	15	-10	140	Ruby	2019F1JRG7	-	D5	8	9	24.0	071
	2	2.3	0.14	-	0	15	15	-10	140	Ruby	2019F1JRG7	-	LA	9	9	24.0	071
	2	2.3	0.14	-	0	15	15	-10	140	Ruby	2019F1JRG7	-	LB-LC	13	16	24.0	071
	2	2.3	0.14	-	0	15	-	-10	140	Ruby	2019F1JRG7	-	XS03	9	-	24.0	071
	2	2.3	0.14	-	0	15	15	-10	140	FDA FKM	2019F1JVG7	-	D4	13	16	24.0	071
	2	2.3	0.14	-	0	15	15	-10	140	FDA FKM	2019F1JVG7	-	D5	8	9	24.0	071
	2	2.3	0.14	-	0	15	15	-10	140	FDA FKM	2019F1JVG7	-	LA	9	9	24.0	071
	2	2.3	0.14	-	0	15	15	-10	140	FDA FKM	2019F1JVG7	-	LB-LC	13	16	24.0	071
	2	2.3	0.14	-	0	15	-	-10	140	FDA FKM	2019F1JVG7	-	XS03	9	-	24.0	071
	2.5	3.2	0.19	-	0	10	10	-10	140	Ruby	2019F1LRG7	-	D4	13	16	24.0	071
	2.5	3.2	0.19	-	0	10	10	-10	140	Ruby	2019F1LRG7	-	D5	8	9	24.0	071
	2.5	3.2	0.19	-	0	10	10	-10	140	Ruby	2019F1LRG7	-	LA	9	9	24.0	071
	2.5	3.2	0.19	-	0	10	10	-10	140	Ruby	2019F1LRG7	-	LB-LC	13	16	24.0	071



## 2 WAY VALVES



For this page	Port size	Orifice (mm)	Kv (l/min)	MOPD (bar)	Fluid Temp (°C)	Amb Temp (°C)
From	SB	1.5	1.3	10	-10	-10
To	SB	2.5	3.2	20	140	50



Drawing 071

## 2 WAY VALVES

# 2/2

## VALVES FOR BEVERAGE DISPENSING - LIQUIPURE® DIRECT OPERATED

STAINLESS ST.  
SUB-BASE MOUNTING

**NORMALLY CLOSED**

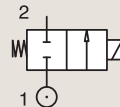

Port size	Orifice Ø mm	Flow factors			Operating Pressure Differential			Fluid Temp.		Seat Seal	Parker Valves			Power		Coil Group	Dwg. No.
		Kv l/min	KV m³/h	Qn l/min	Min bar	Max(MOPD)		Min °C	Max °C		Valve Ref.	Housing Ref.	Coil Ref.	AC W	DC W		
						AC bar	DC bar										
SB	2.5	3.2	0.19	-	0	10	-	-10	140	Ruby	2019F1LRG7	-	XS03	9	-	24.0	071
	2.5	3.2	0.19	-	0	10	10	-10	140	FDA FKM	2019F1LVG7	-	D4	13	16	24.0	071
	2.5	3.2	0.19	-	0	10	10	-10	140	FDA FKM	2019F1LVG7	-	D5	8	9	24.0	071
	2.5	3.2	0.19	-	0	10	10	-10	140	FDA FKM	2019F1LVG7	-	LA	9	9	24.0	071
	2.5	3.2	0.19	-	0	10	10	-10	140	FDA FKM	2019F1LVG7	-	LB-LC	13	16	24.0	071
	2.5	3.2	0.19	-	0	10	-	-10	140	FDA FKM	2019F1LVG7	-	XS03	9	-	24.0	071
	3	4.2	0.25	-	0	7	7	-10	140	Ruby	2019F1NRG7	-	D4	13	16	24.0	071
	3	4.2	0.25	-	0	7	7	-10	140	Ruby	2019F1NRG7	-	D5	8	9	24.0	071
	3	4.2	0.25	-	0	7	7	-10	140	Ruby	2019F1NRG7	-	LA	9	9	24.0	071
	3	4.2	0.25	-	0	7	7	-10	140	Ruby	2019F1NRG7	-	LB-LC	13	16	24.0	071
	3	4.2	0.25	-	0	7	-	-10	140	Ruby	2019F1NRG7	-	XS03	9	-	24.0	071
	3	4.2	0.25	-	0	7	7	-10	140	FDA FKM	2019F1NVG7	-	D4	13	16	24.0	071
	3	4.2	0.25	-	0	7	7	-10	140	FDA FKM	2019F1NVG7	-	D5	8	9	24.0	071
	3	4.2	0.25	-	0	7	7	-10	140	FDA FKM	2019F1NVG7	-	LA	9	9	24.0	071
	3	4.2	0.25	-	0	7	7	-10	140	FDA FKM	2019F1NVG7	-	LB-LC	13	16	24.0	071
	3	4.2	0.25	-	0	7	-	-10	140	FDA FKM	2019F1NVG7	-	XS03	9	-	24.0	071



## 2 WAY VALVES



For this page	Port size	Orifice (mm)	Kv (l/min)	MOPD (bar)	Fluid Temp (°C)	Amb Temp (°C)
From	SB	2.5	3.2	7	-10	-10
To	SB	3	4.2	10	140	50



Drawing 071

## 3 WAY VALVES

## 3 WAY VALVES



# VALVES FOR DRY OR LUBRICATED AIR, NEUTRAL GASES AND LIQUIDS



# 3/2

Actuation	Body	Function	Port Size	Orifice (mm)	Flow Factor Kv(l/min)	MOPD (bar)	Max Fluid Temp. (°C)	Page Parker Valves	Page Parker LUCIFER® Valves	
Direct Operated	Brass/Pipe mounting	Normally Closed	1/8"	1.2 to 2.5	3.5	20	140	208		
			1/8"-1/4"	2.5	3.5	7	75	-	210	
			1/4"	1 to 4.5	7	30	140	208		
		Normally Open	1/4"	1.5 to 3	4.5	16	120	-	218	
			Universal	1/8"	1.5 to 2.5	3.5	10	140	220	
				1/4"	0.8 to 3.5	5	30	140	220	
	Brass/Sub-base mounting	Control by Electric Impulse	Normally Closed	1/4"	1.5	1.5	16	100	-	224
				SB	1.3	1	20	140	226	
				3.5 mm	1.2 to 1.5	0.9	10	75	-	228
		Normally Open	5 mm	1 to 2.5	3.5	16	120	-	228	
			Universal	5 mm	1.5 to 2.5	2.2	15	120	-	230
				1/8"-1/5"	1.5	1.5	10	120	-	232
Pilot Operated	Anodized aluminium/ Banjo	Normally Closed	1/8"	1.2	-	10	50	-	234	
			303 Stainless St./Sub-base mounting	5 mm	1.5	1.5	15	100	-	236
				POM/Sub-base mounting	3 mm	2	2	10	50	-
	Anodized aluminium/ Pipe mounting	Normally Closed	1/4"	6.5 to 8	20	15	75	-	240	
			1/2"	14	-	15	75	-	242	
		Normally Open	1/4"	8	20	40	75	-	242	
1/2"	14		-	15	100	-	244			
Anodized aluminium/ Sub-base mounting/ Poppet	Normally Closed	1/2"	15	-	10	75	-	244		

### 3 WAY VALVES

# 3/2

## VALVES FOR DRY OR LUBRICATED AIR, NEUTRAL GASES AND LIQUIDS DIRECT OPERATED



Industrial Equipment



Commercial Equipment



Process

### BRASS PIPE MOUNTING

#### NORMALLY CLOSED

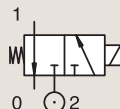

Port size	Orifice Ø		Flow factors			Operating Pressure Differential			Fluid Temp.		Seat Seal	Parker Valves			Power		Coil Group	Dwg. No.	
	1	(2)	1	(2)	1	(2)	Min	Max(MOPD)	Min	Max		Valve Order Number	Valve Type	Coil Type	AC W	DC W			
BSP	mm		Kv l/min		KV l/min		bar	AC bar	DC bar	°C	°C								
1/8"	1.2	1.6	0.7	-	0.04	-	0	8	-	-10	140	FKM	398102 <sub>1</sub>	N79.4IV	WB4.5 115/50-60	4.5	-	1.3	066
	1.2	1.6	0.7	-	0.04	-	0	14	-	-10	140	FKM	398104 <sub>1</sub>	N79.4IV	WB4.5 230/50-60	4.5	-	1.3	066
	1.2	1.6	0.7	-	0.04	-	0	14	-	-10	140	FKM	398120 <sub>1</sub>	N79.4IV	WB4.5 24/50-60	4.5	-	1.3	066
	1.2	1.6	0.7	-	0.04	-	0	14	-	-10	140	FKM	398100 <sub>1</sub>	N79.4IV	WB4.5 42/50-60	4.5	-	1.3	066
	1.5	1.6	1	-	0.06	-	0	8	-	-10	140	FKM	398112 <sub>1</sub>	N79.4AV	WB4.5 230/50-60	4.5	-	1.3	066
	1.5	1.6	1	-	0.06	-	0	8	-	-10	140	FKM	398122 <sub>1</sub>	N79.4AV	WB4.5 24/50-60	4.5	-	1.3	066
	1.5	1.6	1	-	0.06	-	0	8	-	-10	140	FKM	398138 <sub>1</sub>	N79.6AV	WB4.5 115/50-60	4.5	-	1.3	080
	1.5	1.6	1	-	0.06	-	0	8	-	-10	140	FKM	398130U <sub>1</sub>	N79.6AV	WB4.5 115/60	4.5	-	1.3	080
	1.5	1.6	1	-	0.06	-	0	8	-	-10	140	FKM	398114 <sub>1</sub>	N79.6AV	WB4.5 230/50-60	4.5	-	1.3	080
	1.5	1.6	1	-	0.06	-	0	8	-	-10	140	FKM	398142 <sub>1</sub>	N79.6AV	WB4.5 240/50-60	4.5	-	1.3	080
	1.5	1.5	1.2	-	0.07	-	0	20	-	-10	140	FKM	362560J	PM141AV	ZB09	9	-	20.1/20.2	029
	2	1.6	1.5	-	0.09	-	0	5	-	-10	140	FKM	398134U <sub>1</sub>	N79.6BV	WB4.5 115/60	4.5	-	1.3	080
2	1.6	1.5	-	0.09	-	0	5	-	-10	140	FKM	398136U <sub>1</sub>	N79.6BV	WB4.5 208-240/60	4.5	-	1.3	080	
2	1.6	1.5	-	0.09	-	0	5	-	-10	140	FKM	398132 <sub>1</sub>	N79.6BV	WB4.5 230/50-60	4.5	-	1.3	080	
2	2.5	2	-	0.12	-	0	15	-	-10	140	FKM	362570J	PM141BV	ZB09	9	-	20.1/20.2	029	
1/4"	2	2.5	2	-	0.12	-	0	15	-	-10	140	FKM	362620J	PM141FV	ZB09	9	-	20.1/20.2	033
	2.5	2.5	2.8	-	0.17	-	0	9	-	-10	140	FKM	362630J	PM141GV	ZB09	9	-	20.1/20.2	033

**Notes:**

1. Ordering number is for an assembled valve and coil, with the voltage shown.



### 3 WAY VALVES



For this page	Port size	Orifice (mm)	Kv (l/min)	MOPD (bar)	Fluid Temp (°C)	Amb Temp (°C)
From	1/8"	1.2	0.7	5	-10	-10
To	1/4"	2.5	2.8	20	140	50

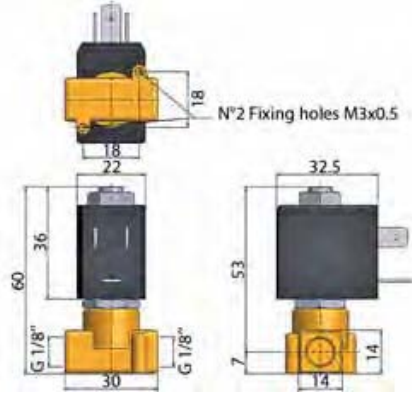

Drawing 066



Drawing 080



Drawing 029

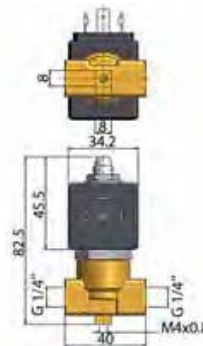

Drawing 033

### 3 WAY VALVES

# 3/2

## VALVES FOR DRY OR LUBRICATED AIR, NEUTRAL GASES AND LIQUIDS DIRECT OPERATED

BRASS  
PIPE MOUNTING

**NORMALLY CLOSED**

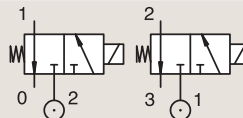

Port size	Orifice Ø		Flow factors				Operating Pressure Differential			Fluid Temp.		Seat Seal	Parker LUCIFER® Valves			IS	Power		Coil Group	Dwg. No.
	1	(2)	1	(2)	1	(2)	Min	Max (MOPD)		Min	Max		Valve Ref.	Housing Ref.	Coil Ref.		AC W	DC W		
								bar	AC bar											
1/8"	1.2	1.5	0.7	0.9	0.04	0.05	0	10	10	-10	75	FKM	131M15	8993	488980	2	2.5	1.1	3382	
	1.5	1.5	0.9	0.9	0.05	0.05	0	7	7	-10	75	FKM	131M14	8993	488980	2	2.5	1.1	3382	
	1.5	1.5	1.5	1.5	0.09	0.09	0	15	15	-10	120	FKM	E131K14	4270	481000	8	8	2.1	3510	
	1.5	1.5	1.5	1.5	0.09	0.09	0	15	15	-10	100	FKM	E131K14	2995	481865	8	9	2.1	3510	
	2	2.5	2.5	3.5	0.15	0.21	0	10	10	-10	120	FKM	131K16	4270	481000	8	8	2.1	3510	
	2	2.5	2.5	3.5	0.15	0.21	0	10	10	-10	100	FKM	131K16	2995	481865	8	9	2.1	3510	
	2	2.5	2.5	3.5	0.15	0.21	0	10	10	-10	120	FKM	131K1650	4270	481000	8	8	2.1	3510	
	2	2.5	2.5	3.5	0.15	0.21	0	10	10	-10	100	FKM	131K1650	2995	481865	8	9	2.1	3510	
	2.5	2.5	3.5	3.5	0.21	0.21	0	7	7	-10	120	FKM	E131K13	4270	481000	8	8	2.0	3510	
	2.5	2.5	3.5	3.5	0.21	0.21	0	7	7	-10	100	FKM	E131K13	2995	481865	8	9	2.0	3510	
1/8"-1/4"	2.5	2.5	3	3	0.18	0.18	0	-	2	-20	75	PUR	131K0397	2995	482740	-	1.6	6.0/8.0	8023	
	2.5	2.5	3	3	0.18	0.18	0	2	2	-20	75	PUR	131K0397	-	495900	2.5	2	6.0/8.0	8023	
	2.5	2.5	3	3	0.18	0.18	0	-	2	-20	75	PUR	131K0397	-	495910	*	-	0.3 to 3	6.0/8.0	8023
	2.5	2.5	3.5	3.5	0.21	0.21	0	7	7	-40	75	PUR	E131K0358	4270	481000	8	8	2.1	3510	
1/4"	2.5	2.5	3.5	3.5	0.21	0.21	0	7	7	-40	75	PUR	E131K0358	2995	481865	8	9	2.1	3510	
	1	1	0.6	0.6	0.03	0.03	0	-	10	-10	55	FKM	131K0490	2995	483580.01	*	-	0.5 to 3	7.0/8.0	7058
	1	1	0.6	0.6	0.03	0.03	0	-	10	-10	75	FKM	131K0490	-	488660.01	*	-	0.3 to 3	7.0/8.0	7058
1	1	0.6	-	0.03	-	0	-	10	-10	75	FKM	131K0490	-	495910	*	-	0.3 to 3	7.0/8.0	7058	

**Notes:**

1. With manual override

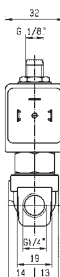
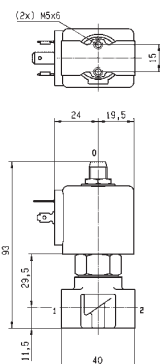

Drawing 7058



### 3 WAY VALVES



For this page	Port size	Orifice (mm)	Kv (l/min)	MOPD (bar)	Fluid Temp (°C)	Amb Temp (°C)
From	1/8"	1	0.6	2	-40	-40
To	1/4"	2.5	3.5	15	120	50

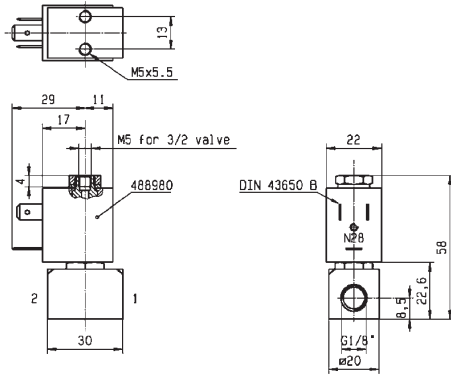

Drawing 3382

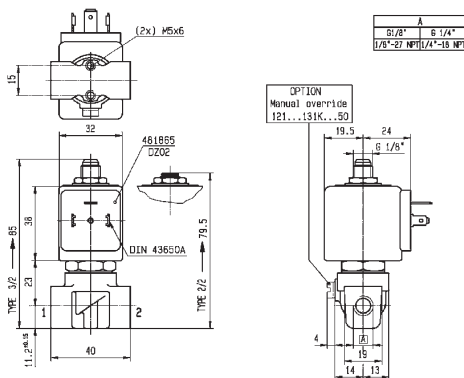

Drawing 3510

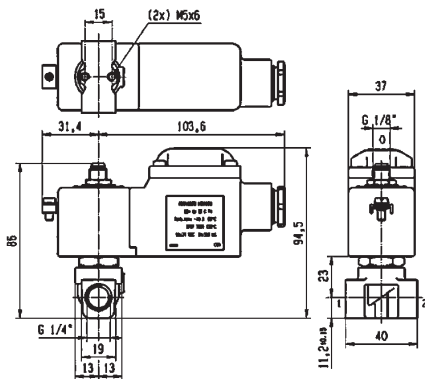

Drawing 8023

### 3 WAY VALVES

# 3/2

## VALVES FOR DRY OR LUBRICATED AIR, NEUTRAL GASES AND LIQUIDS DIRECT OPERATED

BRASS

PIPE MOUNTING

**NORMALLY CLOSED**

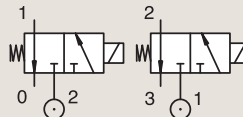

Port size	Orifice Ø		Flow factors				Operating Pressure Differential			Fluid Temp.		Seat Seal	Parker LUCIFER® Valves			IS	Power		Coil Group	Dwg. No.
													Valve Ref.	Housing Ref.	Coil Ref.		AC W	DC W		
	1	(2)	1	(2)	1	(2)	Min	Max (MOPD)	Min	Max	Bar	AC bar				DC bar			Min	Max
1/4"	1.2	1.5	0.8	1.5	0.05	0.09	0	30	-	-30	130	Ruby	E131K64	4270	481000	8	-	2.0	3510	
	1.2	1.5	0.8	1.5	0.05	0.09	0	30	30	-30	140	Ruby	E131K64	4270	486265	14	14	2.0	3510	
	1.2	1.5	0.8	1.5	0.05	0.09	0	30	-	-30	130	Ruby	E131K6450 <sub>1</sub>	4270	481000	8	-	2.0	3510	
	1.2	1.5	0.8	1.5	0.05	0.09	0	30	30	-30	140	Ruby	E131K6450 <sub>1</sub>	4270	486265	14	14	2.0	3510	
	1.5	1.5	1.5	1.5	0.09	0.09	0	-	7	-20	75	PUR	131K0497	2995	482740	-	1.6	6.0/8.0	8023	
	1.5	1.5	1.5	1.5	0.09	0.09	0	7	7	-20	75	PUR	131K0497	-	495900	2.5	2	6.0/8.0	8023	
	1.5	1.5	1.5	1.5	0.09	0.09	0	-	7	-20	75	PUR	131K0497	-	495910	*	-	0.3 to 3	6.0/8.0	8023
	1.5	1.5	1.5	1.5	0.09	0.09	0	-	7	-20	75	PUR	131K0497	2995	496125	-	1.6	6.0/8.0	8023	
	1.5	1.5	1.5	1.5	0.09	0.09	0	16	16	-10	120	FKM	E131K04	4270	481000	8	8	2.0	3510	
	1.5	1.5	1.5	1.5	0.09	0.09	0	16	16	-10	100	FKM	E131K04	2995	481865	8	9	2.0	3510	
	1.5	1.5	1.5	1.5	0.09	0.09	0	16	16	-10	120	FKM	E131K04	4270	486265	14	14	2.0	3510	
	1.5	1.5	1.5	1.5	0.09	0.09	0	15	15	-10	120	FKM	E131K0450 <sub>1</sub>	4270	481000	8	8	2.1	3510	
	1.5	1.5	1.5	1.5	0.09	0.09	0	15	15	-10	100	FKM	E131K0450 <sub>1</sub>	2995	481865	8	9	2.1	3510	
	2	3	2.5	4.5	0.15	0.27	0	10	10	-10	75	FKM	131T23	4270	481000	8	8	2.0	3223	
	2	3	2.5	4.5	0.15	0.27	0	10	10	-10	75	FKM	131T23	2995	481865	8	9	2.0	3223	
	2	3	2.5	4.5	0.15	0.27	0	10	10	-10	75	FKM	131T23	4270	486265	14	14	2.0	3223	
	2	3	2.5	4.5	0.15	0.27	0	10	10	-10	75	FKM	131T2301 <sub>1</sub>	4270	481000	8	8	2.0	3223	
	2	3	2.5	4.5	0.15	0.27	0	10	10	-10	75	FKM	131T2301 <sub>1</sub>	2995	481865	8	9	2.0	3223	
2	3	2.5	4.5	0.15	0.27	0	10	10	-10	75	FKM	131T2301 <sub>1</sub>	4270	486265	14	14	2.0	3223		

**Notes:**

1. With manual override



### 3 WAY VALVES



For this page	Port size	Orifice (mm)	Kv (l/min)	MOPD (bar)	Fluid Temp (°C)	Amb Temp (°C)
From	1/4"	1.2	0.8	7	-30	-20
To	1/4"	2	2.5	30	140	50

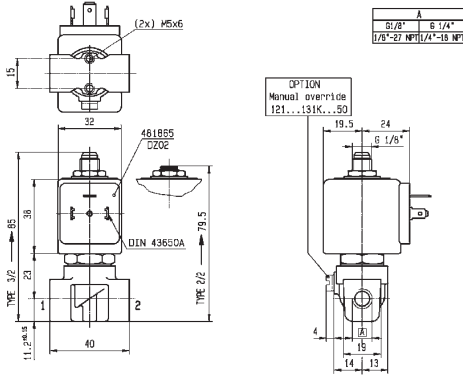

Drawing 3510

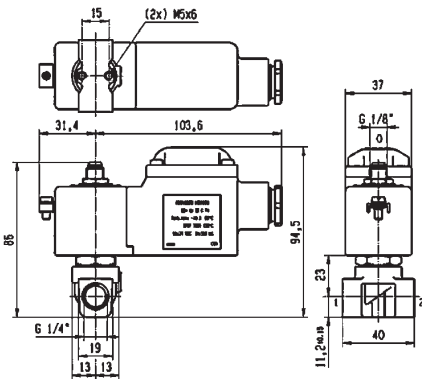

Drawing 8023

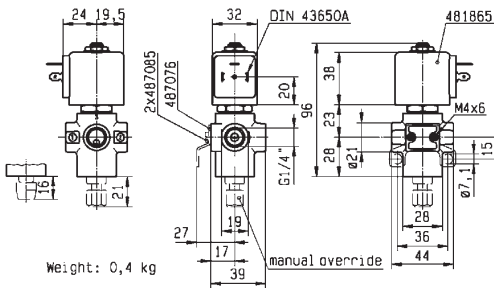

Drawing 3223



### 3 WAY VALVES

# 3/2

## VALVES FOR DRY OR LUBRICATED AIR, NEUTRAL GASES AND LIQUIDS DIRECT OPERATED

### BRASS PIPE MOUNTING

### NORMALLY CLOSED

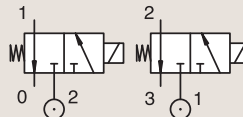

Port size	Orifice Ø	Flow factors				Operating Pressure Differential			Fluid Temp.		Seat Seal	Parker LUCIFER® Valves			Power		Coil Group	Dwg. No.	
		1		(2)		Min	Max (MOPD)		Min	Max		Valve Ref.	Housing Ref.	Coil Ref.	AC W	DC W			
		Kv l/min	KV l/min	bar	AC bar	DC bar	°C	°C											
1/4"	2	2.5	2.5	3.5	0.15	0.21	0	10	10	-10	120	FKM	E131K06	4270	481000	8	8	2.0	8119
	2	2.5	2.5	3.5	0.15	0.21	0	10	10	-10	100	FKM	E131K06	2995	481865	8	9	2.0	8119
	2	2.5	2.5	3.5	0.15	0.21	0	10	10	-10	120	FKM	E131K06	4270	486265	14	14	2.0	8119
	2	2.5	2.5	3.5	0.15	0.21	0	10	10	-10	120	FKM	E131K0650	4270	481000	8	8	2.1	3510
	2	2.5	2.5	3.5	0.15	0.21	0	10	10	-10	100	FKM	E131K0650	2995	481865	8	9	2.1	3510
	2.5	2.5	3	3	0.18	0.18	0	-	2	-20	75	PUR	131K0397	2995	496125	-	1.6	6.0/8.0	8023
	2.5	3.5	3.5	5.5	0.21	0.33	0	7	7	-10	75	FKM	131T29	4270	481000	8	8	2.1	3223
	2.5	3.5	3.5	5.5	0.21	0.33	0	7	7	-10	75	FKM	131T29	2995	481865	8	9	2.1	3223
	2.5	3.5	3.5	5.5	0.21	0.33	0	7	7	-10	75	FKM	131T2901	4270	481000	8	8	2.1	3223
2.5	3.5	3.5	5.5	0.21	0.33	0	7	7	-10	75	FKM	131T2901	2995	481865	8	9	2.1	3223	

#### Notes:

1. With manual override

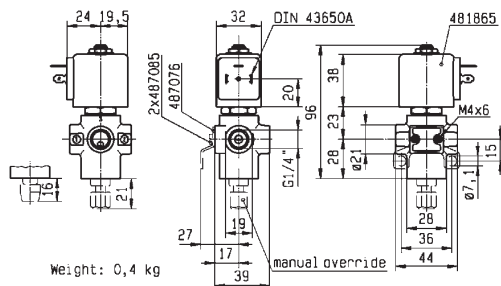

Drawing 3223



### 3 WAY VALVES



For this page	Port size	Orifice (mm)	Kv (l/min)	MOPD (bar)	Fluid Temp (°C)	Amb Temp (°C)
From	1/4"	2	2.5	2	-20	-20
To	1/4"	2.5	3.5	10	120	50

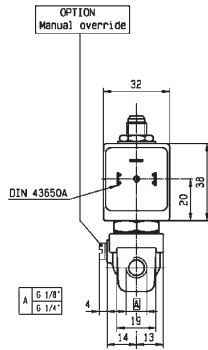
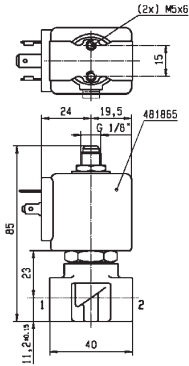

Drawing 8119

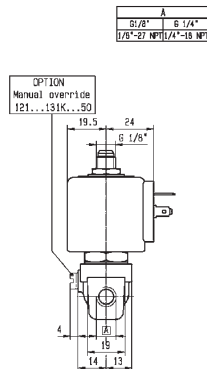
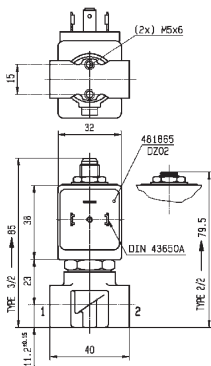

Drawing 3510

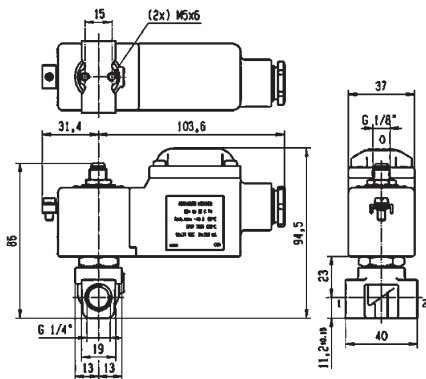

Drawing 8023



### 3 WAY VALVES

# 3/2

## VALVES FOR DRY OR LUBRICATED AIR, NEUTRAL GASES AND LIQUIDS DIRECT OPERATED

BRASS

PIPE MOUNTING

**NORMALLY CLOSED**

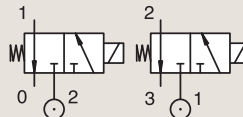

Port size	Orifice Ø		Flow factors				Operating Pressure Differential			Fluid Temp.		Seat Seal	Parker LUCIFER® Valves			Power		Coil Group	Dwg. No.
	1	(2)	1	(2)	1	(2)	Min	Max (MOPD)		Min	Max		Valve Ref.	Housing Ref.	Coil Ref.	AC W	DC W		
								AC bar	DC bar										
1/4"	2.5	6	2.7	15	0.16	0.9	0.1	7	7	-10	75	FKM	E131E03	4270	481000	8	8	2.0	3525
	2.5	6	2.7	15	0.16	0.9	0.1	7	7	-10	75	FKM	E131E03	2995	481865	8	9	2.0	3525
	2.5	6	2.7	15	0.16	0.9	0.1	7	7	-10	75	FKM	E131E03	4270	486265	14	14	2.0	3525
	2.5	2.5	3.5	3.5	0.21	0.21	0	7	7	-10	100	FKM	E131K03	4270	481000	8	8	2.0	3510
	2.5	2.5	3.5	3.5	0.21	0.21	0	7	7	-10	100	FKM	E131K03	2995	481865	8	9	2.0	3510
	2.5	2.5	3.5	3.5	0.21	0.21	0	7	7	-40	75	PUR	E131K0308	4270	481000	8	8	2.1	3510
	2.5	2.5	3.5	3.5	0.21	0.21	0	7	7	-40	75	PUR	E131K0308	2995	481865	8	9	2.1	3510
	2.5	2.5	3.5	3.5	0.21	0.21	0	7	7	-10	120	FKM	E131K0350 <sub>1</sub>	4270	481000	8	8	2.1	3510
	2.5	2.5	3.5	3.5	0.21	0.21	0	7	7	-10	100	FKM	E131K0350 <sub>1</sub>	2995	481865	8	9	2.1	3510
	2.5	2.5	3.5	3.5	0.21	0.21	0	7	7	-30	130	Ruby	E131K63	4270	481000	8	8	2.0	3510
	2.5	2.5	3.5	3.5	0.21	0.21	0	7	7	-30	100	Ruby	E131K63	2995	481865	8	9	2.0	3510
	2.5	2.5	3.5	3.5	0.21	0.21	0	7	7	-30	130	Ruby	E131K6350 <sub>1</sub>	4270	481000	8	8	2.1	3510
	2.5	2.5	3.5	3.5	0.21	0.21	0	7	7	-30	100	Ruby	E131K6350 <sub>1</sub>	2995	481865	8	9	2.1	3510
	3	4	4.5	6	0.27	0.36	0	10	-	-10	75	FKM	131T22	4270	481044	14	-	2.2	3223
	3	4	4.5	6	0.27	0.36	0	10	-	-10	75	FKM	131T22	2995	492425	14	-	2.2	3223
	4.5	6	7	9	0.42	0.54	0	2	2	-10	75	FKM	131T21	4270	481000	8	8	2.0	3223
	4.5	6	7	9	0.42	0.54	0	2	2	-10	75	FKM	131T21	2995	481865	8	9	2.0	3223
	4.5	6	7	9	0.42	0.54	0	2	2	-10	75	FKM	131T21	4270	486265	14	14	2.0	3223

**Notes:**

1. With manual override



### 3 WAY VALVES



For this page	Port size	Orifice (mm)	Kv (l/min)	MOPD (bar)	Fluid Temp (°C)	Amb Temp (°C)
From	1/4"	2.5	2.7	2	-40	-40
To	1/4"	4.5	7	10	130	50

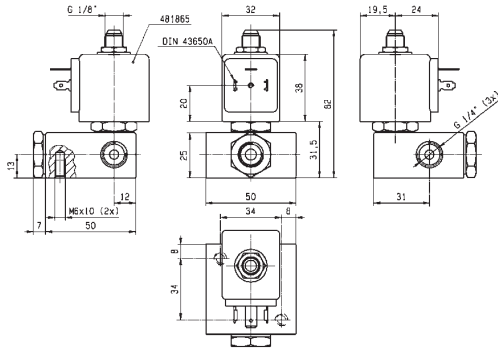

Drawing 3525

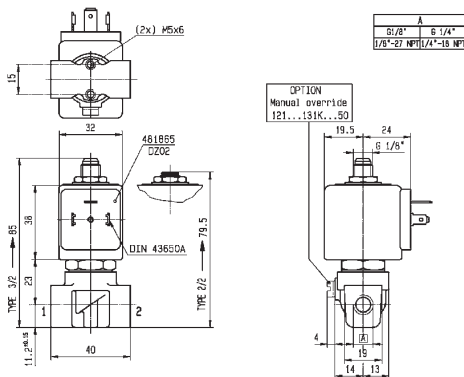

Drawing 3510

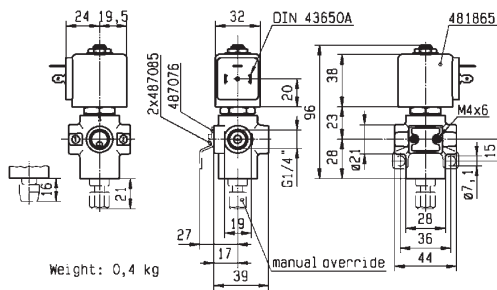

Drawing 3223



### 3 WAY VALVES

# 3/2

## VALVES FOR DRY OR LUBRICATED AIR, NEUTRAL GASES AND LIQUIDS DIRECT OPERATED

BRASS

PIPE MOUNTING

**NORMALLY OPEN**

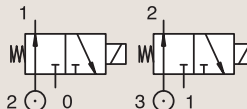

Port size	Orifice Ø		Flow factors				Operating Pressure Differential			Fluid Temp.		Seat Seal	Parker LUCIFER® Valves			Power		Coil Group	Dwg. No.
	1	(2)	1	(2)	1	(2)	Min	Max (MOPD)		Min	Max		Valve Ref.	Housing Ref.	Coil Ref.	AC W	DC W		
								AC bar	DC bar										
1/4"	1.5	1.5	1.4	1.4	0.08	0.08	0	16	16	-10	120	FKM	132K04	4270	481000	8	8	2.1	3510
	1.5	1.5	1.4	1.4	0.08	0.08	0	16	16	-10	100	FKM	132K04	2995	481865	8	9	2.1	3510
	2	2	1.8	1.8	0.10	0.10	0	10	10	-10	120	FKM	132K06	4270	481000	8	8	2.1	3510
	2	2	1.8	1.8	0.10	0.10	0	10	10	-10	100	FKM	132K06	2995	481865	8	9	2.1	3510
	2	3	2.5	4.5	0.15	0.27	0	10	5	-10	75	FKM	132T23	4270	481000	8	8	2.0	3223
	2	3	2.5	4.5	0.15	0.27	0	10	5	-10	75	FKM	132T23	2995	481865	8	9	2.0	3223
	2	3	2.5	4.5	0.15	0.27	0	-	10	-10	75	FKM	132T23	4270	486265	-	14	2.0	3223
	2	3	2.5	4.5	0.15	0.27	0	10	5	-10	75	FKM	132T2301 <sub>1</sub>	4270	481000	8	8	2.0	3223
	2	3	2.5	4.5	0.15	0.27	0	10	5	-10	75	FKM	132T2301 <sub>1</sub>	2995	481865	8	9	2.0	3223
	2	3	2.5	4.5	0.15	0.27	0	-	10	-10	75	FKM	132T2301 <sub>1</sub>	4270	486265	-	14	2.0	3223
	2.5	2.5	2.2	2.2	0.13	0.13	0	7	7	-10	120	FKM	132K03	4270	481000	8	8	2.1	3510
	2.5	2.5	2.2	2.2	0.13	0.13	0	7	7	-10	100	FKM	132K03	2995	481865	8	9	2.1	3510
	3	4	4.5	6	0.27	0.36	0	10	-	-10	75	FKM	132T22	4270	481044	14	-	2.2	3223
	3	4	4.5	6	0.27	0.36	0	7	-	-10	75	FKM	132T22	2995	492425	14	-	2.2	3223

**Notes:**

1. With manual override





### 3 WAY VALVES

# 3/2

## VALVES FOR DRY OR LUBRICATED AIR, NEUTRAL GASES AND LIQUIDS DIRECT OPERATED

BRASS  
PIPE MOUNTING

UNIVERSAL

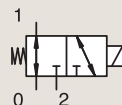

Port size	Orifice Ø		Flow factors				Operating Pressure Differential			Fluid Temp.		Seat Seal	Parker Valves			Power		Coil Group	Dwg. No.
	1	(2)	1	(2)	1	(2)	Min	Max(MOPD)	Min	Max	Valve Order Number		Valve Type	Coil Type	AC W	DC W			
BSP	mm		Kv l/min		KV l/min		bar	AC bar	DC bar	°C	°C								
1/8"	1.5	1.5	1.2	-	0.07	-	0	10	-	-10	140	FKM	362410J	PM139AV	ZB09	9	-	20.1/20.2	022
	1.5	1.5	1.2	-	0.07	-	0	-	10	-10	140	FKM	362410J	PM139AV	ZB12	-	12	20.1/20.2	022
1/4"	2	2	2	-	0.12	-	0	7	-	-10	140	FKM	362460J	PM139FV	ZB09	9	-	20.1/20.2	022
	2	2	2	-	0.12	-	0	-	7	-10	140	FKM	362460J	PM139FV	ZB12	-	12	20.1/20.2	022
	2.5	2.5	2.8	-	0.17	-	0	4	-	-10	140	FKM	362470J	PM139GV	ZB09	9	-	20.1/20.2	022
	2.5	2.5	2.8	-	0.17	-	0	-	4	-10	140	FKM	362470J	PM139GV	ZB12	-	12	20.1/20.2	022
	3.5	2.5	5	-	0.3	-	0	1	-	-10	140	FKM	362475J	PM139LV	ZB09	9	-	20.1/20.2	022
	3.5	2.5	5	-	0.3	-	0	-	1	-10	140	FKM	362475J	PM139LV	ZB12	-	12	20.1/20.2	022



### 3 WAY VALVES



For this page	Port size	Orifice (mm)	Kv (l/min)	MOPD (bar)	Fluid Temp (°C)	Amb Temp (°C)
From	1/8"	1.5	1.2	1	-10	-10
To	1/4"	3.5	5	10	140	50

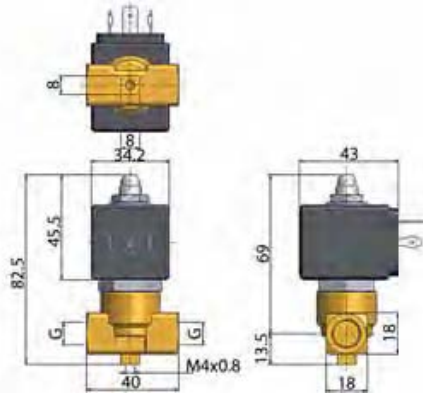

Drawing 022

### 3 WAY VALVES

# 3/2

## VALVES FOR DRY OR LUBRICATED AIR, NEUTRAL GASES AND LIQUIDS DIRECT OPERATED

BRASS  
PIPE MOUNTING

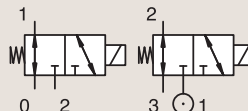

UNIVERSAL

Port size	Orifice Ø		Flow factors		Operating Pressure Differential			Fluid Temp.		Seat Seal	Parker LUCIFER® Valves			IS	Power		Coil Group	Dwg. No.		
	1	(2)	1	(2)	Min	Max (MOPD)		Min	Max		Valve Ref.	Housing Ref.	Coil Ref.		AC W	DC W				
						mm	Kv												KV	bar
1/8"	1.5	1.5	1.5	1.5	0.09	0.09	0	10	10	-10	100	FKM	E133K14	2995	481865	8	9	2.1	3510	
	1.5	1.5	1.5	1.5	0.09	0.09	0	10	10	-10	120	FKM	E133K14	4270	481000	8	8	2.1	3510	
	2	2	2.5	2.5	0.15	0.15	0	7	7	-10	100	FKM	E133K16	2995	481865	8	9	2.1	3510	
	2	2	2.5	2.5	0.15	0.15	0	7	7	-10	120	FKM	E133K16	4270	481000	8	8	2.1	3510	
	2.5	2.5	3.5	3.5	0.21	0.21	0	4	4	-10	100	FKM	E133K13	2995	481865	8	9	2.1	3510	
	2.5	2.5	3.5	3.5	0.21	0.21	0	4	4	-10	120	FKM	E133K13	4270	481000	8	8	2.1	3510	
1/4"	0.8	0.8	0.3	0.3	0.02	0.02	0	30	30	-10	100	FKM	E133K05	2995	481865	8	9	2.1	3510	
	0.8	0.8	0.3	0.3	0.02	0.02	0	30	30	-10	120	FKM	E133K05	4270	481000	8	8	2.1	3510	
	0.8	0.8	0.3	0.3	0.02	0.02	0	30	30	-10	120	FKM	E133K05	4270	486265	14	14	2.0	3510	
	1.5	1.5	1.5	1.5	0.09	0.09	0	-	3	-20	75	PUR	133K0497	2995	482740	-	1.6	6.0/8.0	8023	
	1.5	1.5	1.5	1.5	0.09	0.09	0	3	3	-20	75	PUR	133K0497	-	495900	2.5	2	6.0/8.0	8023	
	1.5	1.5	1.5	1.5	0.09	0.09	0	-	3	-20	75	PUR	133K0497	-	495910	*	-	0.3 to 3	6.0/8.0	8023
	1.5	1.5	1.5	1.5	0.09	0.09	0	-	3	-20	75	PUR	133K0497	2995	496125	-	1.6	6.0/8.0	8023	
	1.5	1.5	1.5	1.5	0.09	0.09	0	10	10	-10	100	FKM	E133K04	2995	481865	8	9	2.0	3510	
	1.5	1.5	1.5	1.5	0.09	0.09	0	10	10	-10	120	FKM	E133K04	4270	481000	8	8	2.0	3510	
	1.5	1.5	1.5	1.5	0.09	0.09	0	10	10	-10	120	FKM	E133K04	4270	486265	14	14	2.0	3510	
	1.5	1.5	1.5	1.5	0.09	0.09	0	10	10	-10	100	FKM	E133K0450 <sub>1</sub>	2995	481865	8	9	2.1	3510	
	1.5	1.5	1.5	1.5	0.09	0.09	0	10	10	-10	120	FKM	E133K0450 <sub>1</sub>	4270	481000	8	8	2.1	3510	
2	2	2.5	2.5	0.15	0.15	0	7	7	-10	75	FKM	133T23	2995	481865	8	9	2.1	3223		
2	2	2.5	2.5	0.15	0.15	0	7	7	-10	75	FKM	133T23	4270	481000	8	8	2.1	3223		
2	2	2.5	2.5	0.15	0.15	0	7	7	-10	75	FKM	133T2301 <sub>1</sub>	2995	481865	8	9	2.1	3223		
2	2	2.5	2.5	0.15	0.15	0	7	7	-10	75	FKM	133T2301 <sub>1</sub>	4270	481000	8	8	2.1	3223		
2	2	2.5	2.5	0.15	0.15	0	7	7	-10	100	FKM	E133K06	2995	481865	8	9	2.0/3.0	3510		
2	2	2.5	2.5	0.15	0.15	0	7	7	-10	120	FKM	E133K06	4270	481000	8	8	2.0/3.0	3510		
2	2	2.5	2.5	0.15	0.15	0	7	7	-10	120	FKM	E133K06	4270	486265	14	14	2.0/3.0	3510		
2	2	2.5	2.5	0.15	0.15	0	7	7	-10	100	FKM	E133K0650 <sub>1</sub>	2995	481865	8	9	2.1	3510		
2	2	2.5	2.5	0.15	0.15	0	7	7	-10	120	FKM	E133K0650 <sub>1</sub>	4270	481000	8	8	2.1	3510		
2.5	2.5	3.5	3.5	0.21	0.21	0	4	4	-10	100	FKM	E133K03	2995	481865	8	9	2.0	3510		
2.5	2.5	3.5	3.5	0.21	0.21	0	4	4	-10	120	FKM	E133K03	4270	481000	8	8	2.0	3510		
2.5	2.5	3.5	3.5	0.21	0.21	0	4	4	-10	120	FKM	E133K03	4270	486265	14	14	2.0	3510		
2.5	2.5	3.5	3.5	0.21	0.21	0	4	4	-10	100	FKM	E133K0350 <sub>1</sub>	2995	481865	8	9	2.1	3510		
2.5	2.5	3.5	3.5	0.21	0.21	0	4	4	-10	120	FKM	E133K0350 <sub>1</sub>	4270	481000	8	8	2.1	3510		
3	3	4.5	4.5	0.27	0.27	0	2	2	-10	75	FKM	133T21	2995	481865	8	9	2.1	3223		
3	3	4.5	4.5	0.27	0.27	0	2	2	-10	75	FKM	133T21	4270	481000	8	8	2.1	3223		

**Notes:**

1. With manual override



### 3 WAY VALVES



For this page	Port size	Orifice (mm)	Kv (l/min)	MOPD (bar)	Fluid Temp (°C)	Amb Temp (°C)
From	1/8"	0.8	0.3	2	-20	-20
To	1/4"	3	4.5	30	120	50

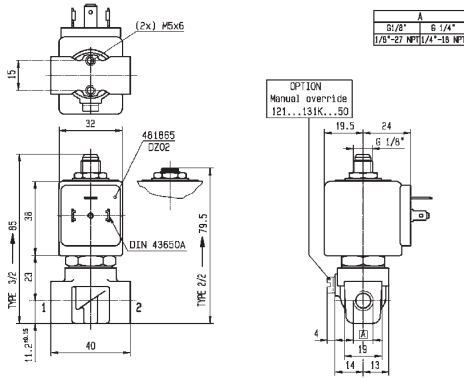

Drawing 3510

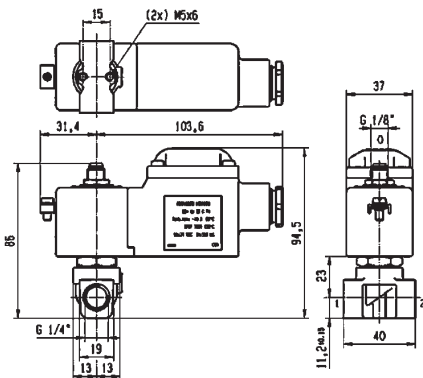

Drawing 8023

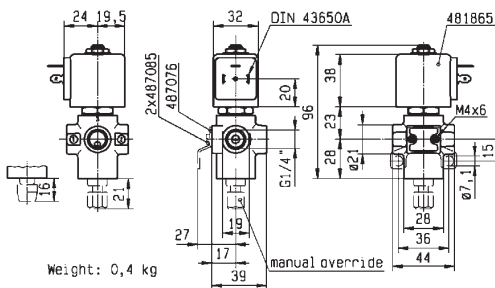

Drawing 3223



### 3 WAY VALVES

# 3/2

VALVES FOR DRY OR LUBRICATED AIR, NEUTRAL GASES AND LIQUIDS  
DIRECT OPERATED

BRASS

PIPE MOUNTING

UNIVERSAL

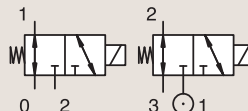

Port size	Orifice Ø		Flow factors		Operating Pressure Differential			Fluid Temp.		Seat Seal	Parker LUCIFER® Valves			Power		Coil Group	Dwg. No.		
	1	(2)	1	(2)	Min	Max (MOPD)	Min	Max	Valve Ref.		Housing Ref.	Coil Ref.	AC W	DC W					
BSP	mm		Kv l/min	KV m³/h	bar	AC bar	DC bar	°C	°C										
1/4"	3	3	4.5	4.5	0.27	0.27	0	2	2	-10	75	FKM	133T2101 <sub>1</sub>	2995	481865	8	9	2.1	3223
	3	3	4.5	4.5	0.27	0.27	0	2	2	-10	75	FKM	133T2101 <sub>1</sub>	4270	481000	8	8	2.1	3223

**Notes:**

1. With manual override

BRASS

PIPE MOUNTING

CONTROL BY ELECTRIC IMPULSE

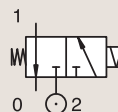

Port size	Orifice Ø		Flow factors		Operating Pressure Differential			Fluid Temp.		Seat Seal	Parker LUCIFER® Valves			Power		Coil Group	Dwg. No.		
	1	(2)	1	(2)	Min	Max (MOPD)	Min	Max	Valve Ref.		Housing Ref.	Coil Ref.	AC W	DC W					
BSP	mm		Kv l/min	KV l/min	bar	AC bar	DC bar	°C	°C										
1/4"	1.5	1.5	1.5	1.5	0.09	0.09	0	-	16	-10	100	FKM	135K04	4269	485400	-	13	4.0	8104



### 3 WAY VALVES



For this page	Port size	Orifice (mm)	Kv (l/min)	MOPD (bar)	Fluid Temp (°C)	Amb Temp (°C)
From	1/4"	1.5	1.5	2	-10	-10
To	1/4"	3	4.5	16	100	50

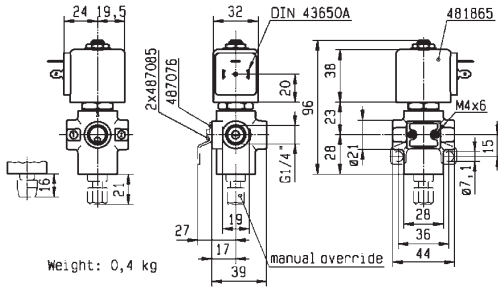

Drawing 3223

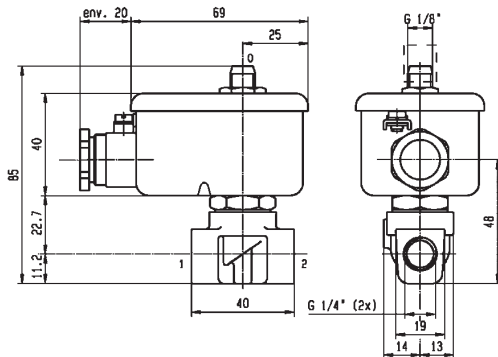

Drawing 8104



### 3 WAY VALVES

# 3/2

VALVES FOR DRY OR LUBRICATED AIR, NEUTRAL GASES AND LIQUIDS  
DIRECT OPERATED

BRASS  
SUB-BASE MOUNTING

**NORMALLY CLOSED**

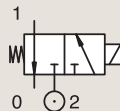

Port size	Orifice Ø		Flow factors				Operating Pressure Differential			Fluid Temp.		Seat Seal	Parker Valves			Power		Coil Group	Dwg. No.
	1	(2)	1	(2)	1	(2)	Min	Max(MOPD)	Min	Max	Valve Order Number		Valve Type	Coil Type	AC W	DC W			
	mm		Kv l/min		KV l/min		bar	AC bar	DC bar	°C							°C		
SB	1.3	2.5	1	-	0.06	-	0	20	10	-30	140	Ruby	360490J <sub>1</sub>	PM128GR	ZB09	9	-	20.1/20.2	009
	1.3	2.5	1	-	0.06	-	0	20	10	-30	140	Ruby	360480J <sub>1</sub>	PM128IR	YB09	9	-	20.1/20.2	010
	1.3	2.5	1	-	0.06	-	0	20	10	-30	140	Ruby	360480J <sub>1</sub>	PM128IR	ZB09	9	-	20.1/20.2	010
	1.3	2.5	1	-	0.06	-	0	20	10	-10	140	FKM	360506 <sub>1</sub>	PM128ISV	ZB09	9	-	20.1/20.2	010
	1.3	2.5	1	-	0.06	-	0	20	10	-10	140	FKM	360479J <sub>1</sub>	PM128IV	ZB09	9	-	20.1/20.2	010

**Notes:**

1. Maximum static pressure: 14.5 Bar (for Viton sealing, maximum static pressure: 12 Bar)



### 3 WAY VALVES



For this page	Port size	Orifice (mm)	Kv (l/min)	MOPD (bar)	Fluid Temp (°C)	Amb Temp (°C)
From	SB	1.3	1	10	-30	-10
To	SB	1.3	1	20	140	50

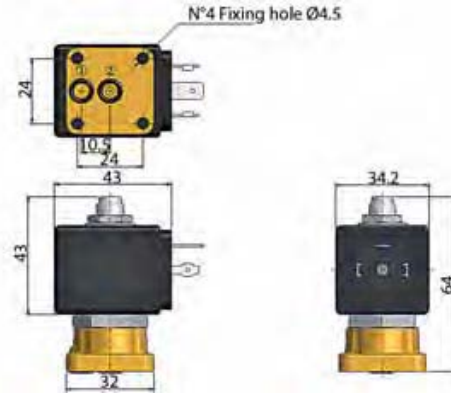

Drawing 009

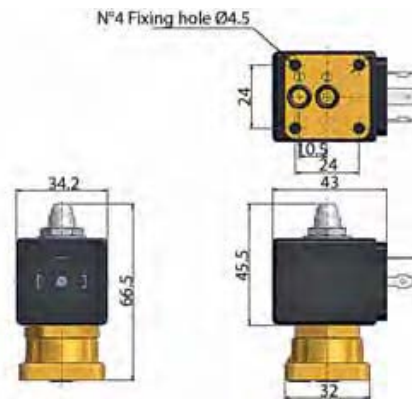

Drawing 010

### 3 WAY VALVES

# 3/2

## VALVES FOR DRY OR LUBRICATED AIR, NEUTRAL GASES AND LIQUIDS DIRECT OPERATED

BRASS

SUB-BASE MOUNTING

**NORMALLY CLOSED**

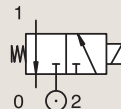

Port size	Orifice Ø		Flow factors				Operating Pressure Differential			Fluid Temp.		Seat Seal	Parker LUCIFER® Valves			IS	Power		Coil Group	Dwg. No.
	1	(2)	1	(2)	1	(2)	Min	Max (MOPD)	Min	Max	Valve Ref.		Housing Ref.	Coil Ref.	AC W		DC W			
	mm		Kv l/min		KV l/min		bar	AC bar	DC bar	°C								°C		
SB	1.2	1.5	0.7	0.9	0.04	0.05	0	10	10	-10	75	FKM	131M75	8993	488980	-	2	2.5	1.1	3383
	1.2	1.5	0.7	0.9	0.04	0.05	0	10	10	-10	75	FKM	131M7550 <sub>1</sub>	8993	488980	-	2	2.5	1.1	3383
	1.5	1.5	0.9	0.9	0.05	0.05	0	7	7	-10	75	FKM	131M74	8993	488980	-	2	2.5	1.1	3383
	1.5	1.5	0.9	0.9	0.05	0.05	0	7	7	-10	75	FKM	131M7450 <sub>1</sub>	8993	488980	-	2	2.5	1.1	3383
	1	1	0.6	0.6	0.03	0.03	0	-	10	-10	75	FKM	131F4490	2995	483580.01	*	-	0.5 to 3	7.0/8.0	7057
	1	1	0.6	0.6	0.03	0.03	0	-	10	-10	75	FKM	131F4490	-	488660.01	*	-	0.3 to 3	7.0/8.0	7057
	1	1	0.6	0.6	0.03	0.03	0	-	10	-10	75	FKM	131F4490	-	495910	*	-	0.3 to 3	7.0/8.0	7057
	1.5	2	1.5	2.2	0.09	0.13	0	-	16	-10	100	FKM	131F4410	2995	481865	-	-	9	2.1	3509
	1.5	1.5	1.5	1.5	0.09	0.09	0	-	7	-20	75	PUR	131F4497	2995	482740	-	-	1.6	6.0/8.0	8022
	1.5	1.5	1.5	1.5	0.09	0.09	0	7	7	-20	75	PUR	131F4497	-	495900	-	2.5	2	6.0/8.0	8022
	1.5	1.5	1.5	1.5	0.09	0.09	0	-	7	-20	75	PUR	131F4497	-	495910	*	-	0.3 to 3	6.0/8.0	8022
	1.5	1.5	1.5	1.5	0.09	0.09	0	-	7	-20	75	PUR	131F4497	2995	496125	-	-	1.6	6.0/8.0	8022

**Notes:**

1. With manual override

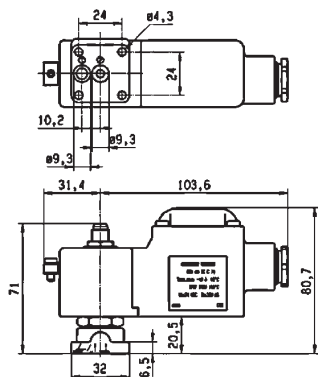

Drawing 8022



### 3 WAY VALVES



For this page	Port size	Orifice (mm)	Kv (l/min)	MOPD (bar)	Fluid Temp (°C)	Amb Temp (°C)
From	SB	1	0.6	7	-20	-20
To	SB	1.5	1.5	16	100	50

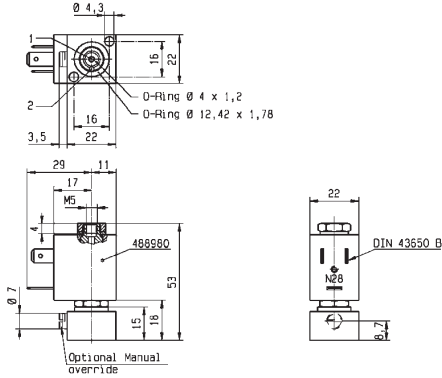

Drawing 3383

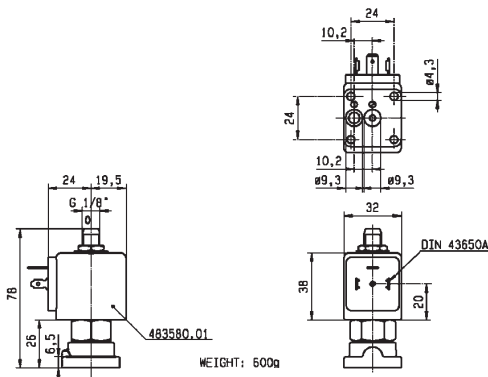

Drawing 7057

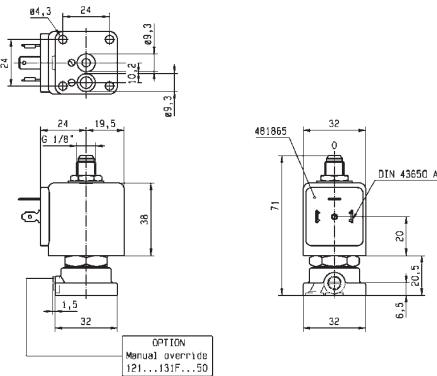

Drawing 3509



### 3 WAY VALVES

# 3/2

## VALVES FOR DRY OR LUBRICATED AIR, NEUTRAL GASES AND LIQUIDS DIRECT OPERATED

### BRASS

### SUB-BASE MOUNTING

### NORMALLY CLOSED

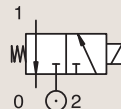

Port size	Orifice Ø		Flow factors		Operating Pressure Differential			Fluid Temp.		Seat Seal	Parker LUCIFER® Valves			Power		Coil Group	Dwg. No.		
	1	(2)	1	(2)	Min	Max (MOPD)	Min	Max	Valve Ref.		Housing Ref.	Coil Ref.	AC W	DC W					
	mm		Kv l/min	KV m³/h	bar	AC bar	DC bar	°C							°C				
SB	1.5	1.5	1.5	1.5	0.09	0.09	0	15	15	-10	100	FKM	E131F44	2995	481865	8	9	2.1	3509
	1.5	1.5	1.5	1.5	0.09	0.09	0	15	15	-10	120	FKM	E131F44	4270	481000	8	8	2.1	3509
	1.5	1.5	1.5	1.5	0.09	0.09	0	15	15	-10	100	FKM	E131F4450 <sub>1</sub>	2995	481865	8	9	2.1	3509
	1.5	1.5	1.5	1.5	0.09	0.09	0	15	15	-10	100	FKM	E131F4450 <sub>1</sub>	4270	481000	8	8	2.1	3509
	2	2.5	2.5	3.5	0.15	0.21	0	10	10	-10	100	FKM	131F46	2995	481865	8	9	2.1	3509
	2	2.5	2.5	3.5	0.15	0.21	0	10	10	-10	120	FKM	131F46	4270	481000	8	8	2.1	3509
	2	2.5	2.5	3.5	0.15	0.21	0	10	10	-10	100	FKM	131F4650 <sub>1</sub>	2995	481865	8	9	2.1	3509
	2	2.5	2.5	3.5	0.15	0.21	0	10	10	-10	120	FKM	131F4650 <sub>1</sub>	4270	481000	8	8	2.1	3509
	2.5	2.5	3.5	3.5	0.21	0.21	0	7	7	-10	100	FKM	E131F43	2995	481865	8	9	2.1	3509
	2.5	2.5	3.5	3.5	0.21	0.21	0	7	7	-10	120	FKM	E131F43	4270	481000	8	8	2.1	3509
	2.5	2.5	3.5	3.5	0.21	0.21	0	7	7	-10	100	FKM	E131F4350 <sub>1</sub>	2995	481865	8	9	2.0	3509
	2.5	2.5	3.5	3.5	0.21	0.21	0	7	7	-10	120	FKM	E131F4350 <sub>1</sub>	4270	481000	8	8	2.0	3509
2.5	2.5	3.5	3.5	0.21	0.21	0	7	7	-10	100	FKM	E131F4350 <sub>1</sub>	4270	486265	14	14	2.0	3509	

#### Notes:

1. With manual override

### BRASS

### SUB-BASE MOUNTING

### NORMALLY OPEN

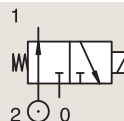

Port size	Orifice Ø		Flow factors		Operating Pressure Differential			Fluid Temp.		Seat Seal	Parker LUCIFER® Valves			Power		Coil Group	Dwg. No.		
	1	(2)	1	(2)	Min	Max (MOPD)	Min	Max	Valve Ref.		Housing Ref.	Coil Ref.	AC W	DC W					
	mm		Kv l/min	KV m³/h	bar	AC bar	DC bar	°C							°C				
SB	1.5	1.5	1.4	1.4	0.084	0.084	0	15	15	-10	75	FKM	132F44	4270	481000	8	8	2.1	3509
	1.5	1.5	1.4	1.4	0.084	0.084	0	15	15	-10	75	FKM	132F44	2995	481865	8	9	2.1	3509
	2	2	1.8	1.8	0.108	0.108	0	10	10	-10	120	FKM	132F46	4270	481000	8	8	2.1	3509
	2	2	1.8	1.8	0.108	0.108	0	10	10	-10	100	FKM	132F46	2995	481865	8	9	2.1	3509
	2.5	2.5	2.2	2.2	0.132	0.132	0	7	7	-10	75	FKM	132F43	4270	481000	8	8	2.0	3509
	2.5	2.5	2.2	2.2	0.132	0.132	0	7	7	-10	75	FKM	132F43	2995	481865	8	9	2.0	3509
	2.5	2.5	2.2	2.2	0.132	0.132	0	7	7	-10	75	FKM	132F43	4270	486265	14	14	2.0	3509



### 3 WAY VALVES



For this page	Port size	Orifice (mm)	Kv (l/min)	MOPD (bar)	Fluid Temp (°C)	Amb Temp (°C)
From	SB	1.5	1.4	7	-10	-30
To	SB	2.5	3.5	15	120	50

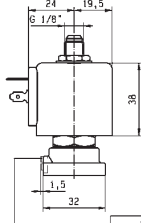
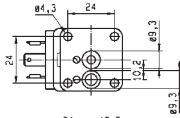

OPTION  
Manual override  
121...131F...50



Drawing 3509

### 3 WAY VALVES

# 3/2

VALVES FOR DRY OR LUBRICATED AIR, NEUTRAL GASES AND LIQUIDS  
DIRECT OPERATED

BRASS

SUB-BASE MOUNTING

UNIVERSAL

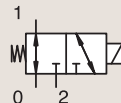

Port size	Orifice Ø		Flow factors		Operating Pressure Differential			Fluid Temp.		Seat Seal	Parker LUCIFER® Valves			Power		Coil Group	Dwg. No.		
	1	(2)	1	(2)	Min	Max (MOPD)		Min	Max		Valve Ref.	Housing Ref.	Coil Ref.	AC W	DC W				
	mm	Kv l/min	KV l/min	bar	AC bar	DC bar	°C	°C											
SB	1.5	1.5	1.5	1.5	0.09	0.09	0	10	10	-10	100	FKM	E133F4450	4270	481000	8	8	2.1	3509
	1.5	1.5	1.5	1.5	0.09	0.09	0	10	10	-10	120	FKM	E133F4450	2995	481865	8	9	2.1	3509
	1.5	1.5	1.5	1.5	0.09	0.09	0	10	10	-10	120	FKM	E133F44	4270	481000	8	8	2.1	3509
	1.5	1.5	1.5	1.5	0.09	0.09	0	10	10	-10	100	FKM	E133F44	2995	481865	8	9	2.1	3509
	2	2	2.5	2.5	0.15	0.15	0	7	7	-10	120	FKM	133F46	4270	481000	8	8	2.1	3509
	2	2	2.5	2.5	0.15	0.15	0	7	7	-10	100	FKM	133F46	2995	481865	8	9	2.1	3509
	2.5	2.5	3.5	3.5	0.21	0.21	0	4	4	-10	120	FKM	E133F43	4270	481000	8	8	2.1	3509
	2.5	2.5	3.5	3.5	0.21	0.21	0	4	4	-10	100	FKM	E133F43	2995	481865	8	9	2.1	3509

**Notes:**

1. With manual override



### 3 WAY VALVES



For this page	Port size	Orifice (mm)	Kv (l/min)	MOPD (bar)	Fluid Temp (°C)	Amb Temp (°C)
From	SB	1.5	1.5	4	-10	-10
To	SB	2.5	3.5	10	120	50

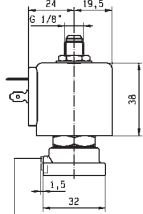
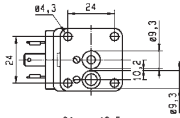

OPTION  
Manual override  
121...131F...50

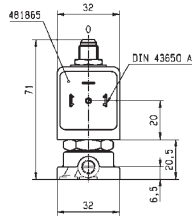

Drawing 3509

### 3 WAY VALVES

# 3/2

## VALVES FOR DRY OR LUBRICATED AIR, NEUTRAL GASES AND LIQUIDS DIRECT OPERATED

### ANODIZED ALUMINIUM

### BANJO

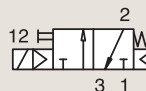

### NORMALLY CLOSED

Port size	Orifice Ø	Flow factor	Operating Pressure Differential			Fluid Temp.		Seat Seal	Parker LUCIFER® Valves			Power		Coil Group	Dwg. No.	
			1	Min	Max (MOPD)		Min		Max	Valve Ref.	Housing Ref.	Coil Ref.	AC W			DC W
					Qn l/min	AC bar										
BSP	mm		bar	AC bar	DC bar	°C	°C									
1.2	50	0	10	10	-10	50	NBR	131B14 <sub>12</sub>	-	496131	3	3	1.2	8227		
1/8"	1.2	50	0	10	10	-10	50	NBR	131B14 <sub>12</sub>	-	496482	3	3	1.2	8227	
	1.2	50	0	10	10	-10	50	NBR	131B14 <sub>12</sub>	-	496637	3	3	1.2	8227	

#### Notes:

1. Valve only compatible with air and neutral gases
2. With manual override

### ANODIZED ALUMINIUM

### BANJO

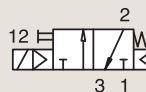

### NORMALLY CLOSED

Port size	Orifice Ø	Flow factor	Operating Pressure Differential			Fluid Temp.		Seat Seal	Parker LUCIFER® Valves			Power		Coil Group	Dwg. No.	
			1	Min	Max (MOPD)		Min		Max	Valve Ref.	Housing Ref.	Coil Ref.	AC W			DC W
					Qn l/min	AC bar										
BSP	mm		bar	AC bar	DC bar	°C	°C									
1.2	50	0	10	10	-10	50	NBR	131B04 <sub>12</sub>	-	496131	3	3	1.2	8226		
1/4"	1.2	50	0	10	10	-10	50	NBR	131B04 <sub>12</sub>	-	496482	3	3	1.2	8226	
	1.2	50	0	10	10	-10	50	NBR	131B04 <sub>12</sub>	-	496637	3	3	1.2	8226	

#### Notes:

1. Valve only compatible with air and neutral gases
2. With manual override



### 3 WAY VALVES



For this page	Port size	Orifice (mm)	Qn (l/min)	MOPD (bar)	Fluid Temp (°C)	Amb Temp (°C)
From	1/8"	1.2	50	10	-10	-10
To	1/8"	1.2	50	10	50	50

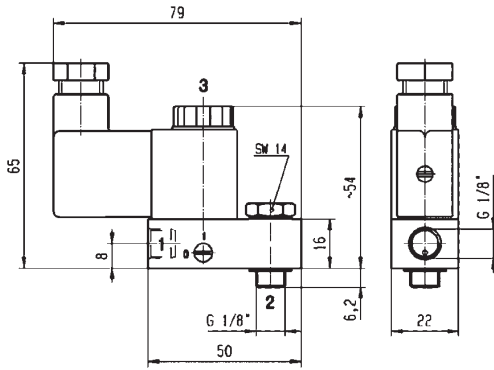

Drawing 8227

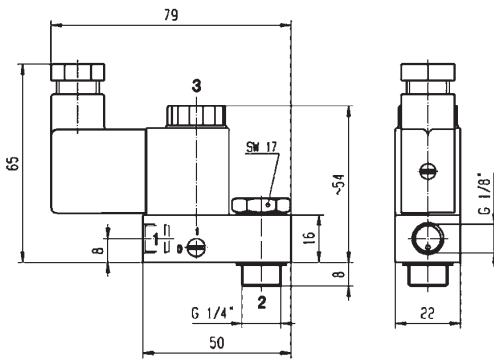

Drawing 8226



### 3 WAY VALVES

# 3/2

VALVES FOR DRY OR LUBRICATED AIR, NEUTRAL GASES AND LIQUIDS  
DIRECT OPERATED

303 STAINLESS ST.  
SUB-BASE MOUNTING

**NORMALLY CLOSED**

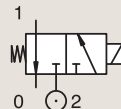

Port size	Orifice Ø		Flow factors				Operating Pressure Differential			Fluid Temp.		Seat Seal	Parker LUCIFER® Valves			Power		Coil Group	Dwg. No.
	1	(2)	1	(2)	1	(2)	Min	Max (MOPD)		Min	Max		Valve Ref.	Housing Ref.	Coil Ref.	AC	DC		
	mm		Kv l/min		KV l/min		bar	AC	DC	°C	°C					W	W		
SB	1.5	1.5	1.5	2.2	0.09	0.13	0	15	15	-10	100	NBR	131F5406	2995	481865	8	9	2.1	3509



### 3 WAY VALVES



For this page	Port size	Orifice (mm)	Kv (l/min)	MOPD (bar)	Fluid Temp (°C)	Amb Temp (°C)
From	SB	1.5	1.5	15	-10	-10
To	SB	1.5	1.5	15	100	50

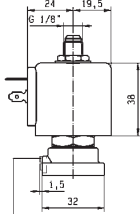
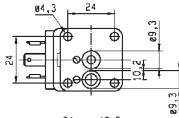

OPTION  
Manual override  
121...131F...50

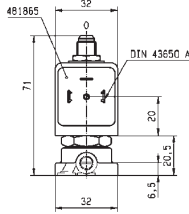

Drawing 3509

### 3 WAY VALVES

# 3/2

VALVES FOR DRY OR LUBRICATED AIR, NEUTRAL GASES AND LIQUIDS  
DIRECT OPERATED

POM

SUB-BASE MOUNTING

**NORMALLY CLOSED**

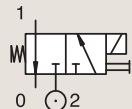

Port size	Orifice Ø		Flow factors		Operating Pressure Differential			Fluid Temp.		Seat Seal	Parker LUCIFER® Valves			Power		Coil Group	Dwg. No.		
	1	(2)	1	(2)	Min	Max (MOPD)	Min	Max	Valve Ref.		Housing Ref.	Coil Ref.	AC W	DC W					
	mm	Kv l/min	KV l/min	bar	AC bar	DC bar	°C	°C											
SB	2	2	2	2	0.12	0.12	0	10	10	-10	50	FKM	E131F26 <sub>12</sub>	2995	481865	8	9	2.1/3.0	3601
	2	2	2	2	0.12	0.12	0	10	10	-10	50	FKM	E131F26 <sub>2</sub>	2995	482730	6	7	2.1/3.0	3601

**Notes:**

- 1. 20% Switch-on - max. 2 min
- 2. With manual override



### 3 WAY VALVES



For this page	Port size	Orifice (mm)	Kv (l/min)	MOPD (bar)	Fluid Temp (°C)	Amb Temp (°C)
From	SB	2	2	10	-10	-10
To	SB	2	2	10	50	50

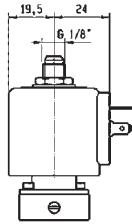
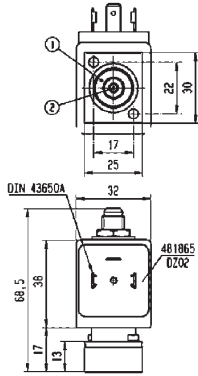

Drawing 3601

### 3 WAY VALVES

# 3/2

## VALVES FOR DRY OR LUBRICATED AIR, NEUTRAL GASES AND LIQUIDS PILOT OPERATED



Industrial Equipment



Process

### ANODIZED ALUMINIUM PIPE MOUNTING

#### NORMALLY CLOSED

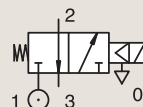

Port size	Orifice Ø		Flow factors				Operating Pressure Differential			Fluid Temp.		Seat Seal	Parker LUCIFER® Valves			IS	Power		Coil Group	Dwg. No.
	1	(2)	1	(2)	1	(2)	Min	Max (MOPD)	Min	Max	Valve Ref.		Housing Ref.	Coil Ref.	AC W		DC W			
BSP	mm		Kv l/min		KV l/min		bar	AC bar	DC bar	°C	°C									
1/4"	6.5	6.5	10	-	0.6	-	1	-	10	-10	55	NBR	331B7490 <sub>1</sub>	2995	483580.01	*	-	0.5 to 3	7.0/8.0	8270
	6.5	6.5	10	-	0.6	-	1	-	10	-10	75	NBR	331B7490 <sub>1</sub>	-	488660.01	*	-	0.3 to 3	7.0/8.0	8270
	6.5	6.5	10	-	0.6	-	1	-	10	-10	75	NBR	331B7490 <sub>1</sub>	-	495910	*	-	0.3 to 3	7.0/8.0	8270
	6.5	-	10	-	0.6	-	1	10	10	-10	75	NBR	E331B74 <sub>13</sub>	2995	481865		8	9	2.1	3240
	6.5	-	10	-	0.6	-	1	10	10	-10	75	NBR	E331B74 <sub>13</sub>	4270	485100		8	8	2.1	3240
	8	8	20	20	1.2	1.2	1	15	15	-10	75	FKM	E331B01 <sub>2</sub>	4270	481000		8	8	2.1	3234
	8	8	20	20	1.2	1.2	1	15	15	-10	75	FKM	E331B01 <sub>2</sub>	2995	481865		8	9	2.1	3234
	8	8	20	20	1.2	1.2	1	15	15	-10	75	FKM	E331B01 <sub>2</sub>	-	483371		8	8	2.1	3234

#### Notes:

1. Valve only compatible with air and neutral gases
2. Valve only compatible with hydraulic oil and air/neutral gases
3. With manual override



### 3 WAY VALVES



For this page	Port size	Orifice (mm)	Kv (l/min)	MOPD (bar)	Fluid Temp (°C)	Amb Temp (°C)
From	1/4"	6.5	10	10	-10	-10
To	1/4"	8	20	15	75	50

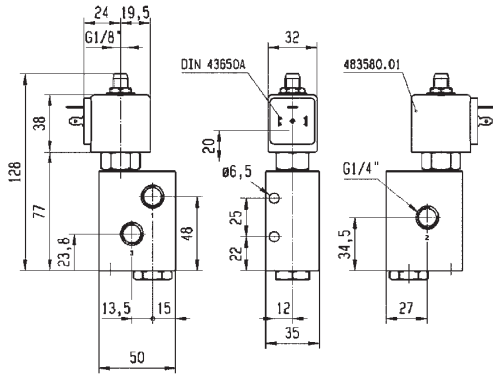

Drawing 8270

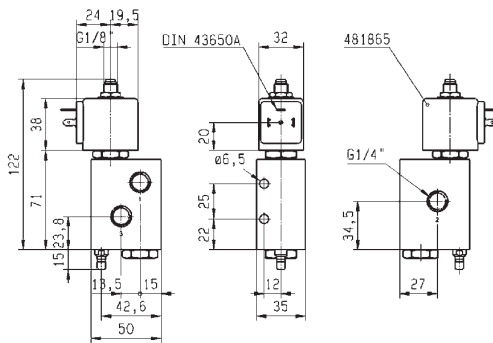

Weight: 0,51 kg

Drawing 3240

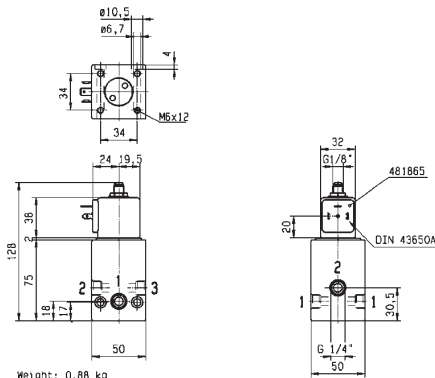

Weight: 0,88 kg

Drawing 3234



### 3 WAY VALVES

# 3/2

## VALVES FOR DRY OR LUBRICATED AIR, NEUTRAL GASES AND LIQUIDS PILOT OPERATED

### ANODIZED ALUMINIUM PIPE MOUNTING

#### NORMALLY CLOSED

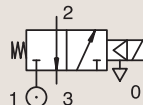

Port size	Orifice Ø		Flow factors		Operating Pressure Differential			Fluid Temp.		Seat Seal	Parker LUCIFER® Valves			Power		Coil Group	Dwg. No.		
	1	(2)	1	(2)	1	(2)	Min	Max (MOPD)	Min		Max	Valve Ref.	Housing Ref.	Coil Ref.	AC W			DC W	
BSP	mm		Kv l/min		KV l/min		bar	AC bar	DC bar	°C	°C								
1/2"	14	14	-	-	-	-	1	15	-	-10	75	FKM	E331B21 <sub>1</sub>	2995	482722	10	-	2.1	3238
	14	14	-	-	-	-	1	15	15	-10	75	FKM	E331B21 <sub>1</sub>	-	483371	8	8	2.1	3238

**Notes:**

1. Valve only compatible with air and neutral gases

### ANODIZED ALUMINIUM PIPE MOUNTING

#### NORMALLY OPEN

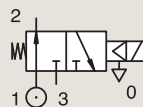

Port size	Orifice Ø		Flow factors		Operating Pressure Differential			Fluid Temp.		Seat Seal	Parker LUCIFER® Valves			Power		Coil Group	Dwg. No.		
	1	(2)	1	(2)	1	(2)	Min	Max (MOPD)	Min		Max	Valve Ref.	Housing Ref.	Coil Ref.	AC W			DC W	
BSP	mm		Kv l/min		KV l/min		bar	AC bar	DC bar	°C	°C								
1/4"	8	8	10	10	0.6	0.6	1	40	40	-10	75	PCTFE	332B02 <sub>12</sub>	2995	481865	8	9	2.1	8114
	8	8	10	10	0.6	0.6	1	40	40	-10	75	PCTFE	332B02 <sub>12</sub>	4270	481000	8	8	2.1	8114
	8	8	20	20	1.2	1.2	1	15	15	-10	75	FKM	E332B01 <sub>2</sub>	2995	481865	8	9	2.1	3234
	8	8	20	20	1.2	1.2	1	15	15	-10	75	FKM	E332B01 <sub>2</sub>	4270	481000	8	8	2.1	3234
	8	8	20	20	1.2	1.2	1	15	15	-10	75	FKM	E332B01 <sub>2</sub>	-	483371	8	8	2.1	3234
	8	8	20	20	1.2	1.2	1	15	15	-10	75	FKM	E332B01 <sub>2</sub>	-	483371	8	8	2.1	3234

**Notes:**

1. Pilot seat discs in Kel-F (PCTFE); valve with pilot return pipe  
2. Valve only compatible with hydraulic oil and air/neutral gases



### 3 WAY VALVES



For this page	Port size	Orifice (mm)	Kv (l/min)	MOPD (bar)	Fluid Temp (°C)	Amb Temp (°C)
From	1/4"	8	10	15	-10	-10
To	1/2"	14	20	40	75	50

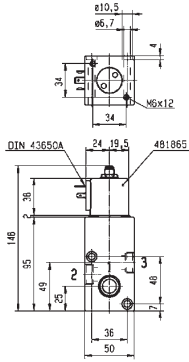

Weight: 0,98 kg



Drawing 3238

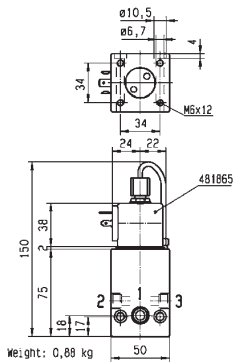

Weight: 0,88 kg



Drawing 8114

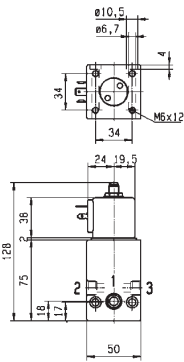

Weight: 0,88 kg



Drawing 3234



### 3 WAY VALVES

# 3/2

## VALVES FOR DRY OR LUBRICATED AIR, NEUTRAL GASES AND LIQUIDS PILOT OPERATED

### ANODIZED ALUMINIUM PIPE MOUNTING

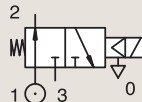

### NORMALLY OPEN

Port size	Orifice Ø		Flow factor Qn l/min	Operating Pressure Differential			Fluid Temp.		Seat Seal	Parker LUCIFER® Valves			Power		Coil Group	Dwg. No.
	1	(2)		Min	Max (MOPD)		Min	Max		Valve Ref.	Housing Ref.	Coil Ref.	AC W	DC W		
	mm	mm			bar	AC bar										
BSP	14	14	2500	1	15	15	-10	100	FKM	E332B21 <sub>1</sub>	2995	481865	8	9	2.1	3238
1/2"	14	14	2500	1	15	15	-10	100	FKM	E332B21 <sub>1</sub>	4270	481000	8	8	2.1	3238

#### Notes:

1. Valve only compatible with air and neutral gases

### ANODIZED ALUMINIUM SUB-BASE MOUNTING

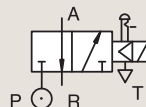

### NORMALLY CLOSED

Port size	Orifice Ø		Flow factor Qn l/min	Operating Pressure Differential			Fluid Temp.		Seat Seal	Parker LUCIFER® Valves			Power		Coil Group	Dwg. No.
	1	(2)		Min	Max (MOPD)		Min	Max		Valve Ref.	Housing Ref.	Coil Ref.	AC W	DC W		
	mm	mm			bar	AC bar										
SB	15	5000	0.5	10	10	-10	75	FKM	E331L21 <sub>1</sub>	2995	481865	8	9	2.1/3.0	3130	
	15	5000	0.5	10	10	-10	75	FKM	E331L21 <sub>1</sub>	-	483371	8	8	2.1/3.0	3130	

#### Notes:

1. With manual override



### 3 WAY VALVES



For this page	Port size	Orifice (mm)	Qn (l/min)	MOPD (bar)	Fluid Temp (°C)	Amb Temp (°C)
From	1/2"	14	-	10	-10	-10
To	1/2"	15	5000	15	100	50

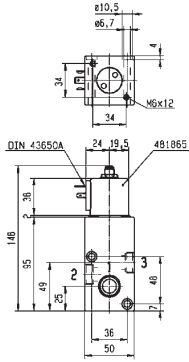

Weight: 0,98 kg

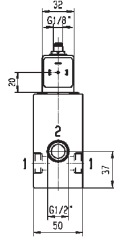

Drawing 3238

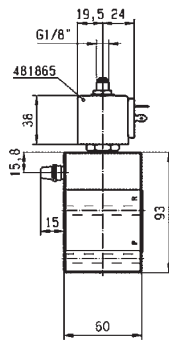
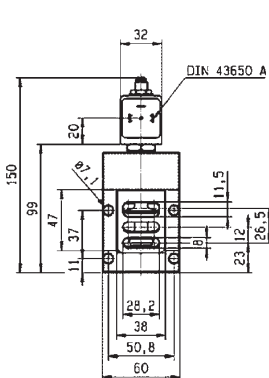

Drawing 3130

## 3 WAY VALVES

## 3 WAY VALVES



VALVES FOR HYDRAULIC OIL AND  
NEUTRAL LIQUIDS (UP TO 75 BAR)



# 3/2

Actuation	Body	Function	Port Size	Orifice (mm)	Flow Factor Kv(l/min)	MOPD (bar)	Max Fluid Temp. (°C)	Page Parker Valves	Page Parker LUCIFER® Valves
Pilot Operated	Anodized aluminium/ Pipe mounting	Normally Closed	1/4"	8	10	40	75	-	248

### 3 WAY VALVES

# 3/2

## VALVES FOR HYDRAULIC OIL AND NEUTRAL LIQUIDS (UP TO 75 BAR) PILOT OPERATED



Process



Industrial Equipment

### ANODIZED ALUMINIUM PIPE MOUNTING

#### NORMALLY CLOSED

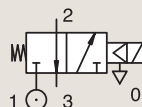

Port size	Orifice Ø		Flow factors				Operating Pressure Differential			Fluid Temp.		Seat Seal	Parker LUCIFER® Valves			Power		Coil Group	Dwg. No.
	1	(2)	1	(2)	1	(2)	Min	Max (MOPD)	Min	Max	Valve Ref.		Housing Ref.	Coil Ref.	AC W	DC W			
	mm		Kv l/min	KV m³/h	bar	AC bar	DC bar	°C	°C										
1/4"	8	8	10	10	0.6	0.6	1	40	40	-10	75	NBR	331B02 <sub>12</sub>	2995	481865	8	9	2.1	8114
	8	8	10	10	0.6	0.6	1	40	40	-10	75	NBR	331B02 <sub>12</sub>	4270	481000	8	8	2.1	8114
	8	8	10	10	0.6	0.6	1	40	40	-10	75	NBR	331B0216 <sub>13</sub>	2995	481865	8	9	2.1	8114
	8	8	10	10	0.6	0.6	1	40	40	-10	75	NBR	331B0216 <sub>13</sub>	4270	481000	8	8	2.1	8114

#### Notes:

1. Pilot seat discs in Kel-F (PCTFE); valve with pilot return pipe
2. Valve only compatible with hydraulic oil
3. Valve only compatible with air / neutral gases



### 3 WAY VALVES



For this page	Port size	Orifice (mm)	Kv (l/min)	MOPD (bar)	Fluid Temp (°C)	Amb Temp (°C)
From	1/4"	8	10	40	-10	-10
To	1/4"	8	10	40	75	50

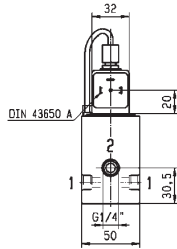
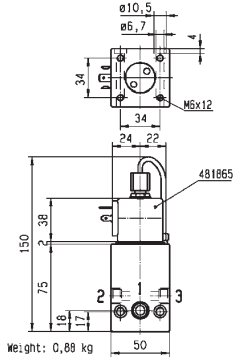

Drawing 8114

## 3 WAY VALVES

## 3 WAY VALVES



### HIGH CORROSION RESISTANT VALVES (303 STAINLESS STEEL)



# 3/2

Actuation	Body	Function	Port Size	Orifice (mm)	Flow Factor Kv(l/min)	MOPD (bar)	Max Fluid Temp. (°C)	Page Parker Valves	Page Parker LUCIFER® Valves
Direct Operated	303 Stainless St./Pipe mounting	Normally Closed	1/4"	1 to 2.5	3.5	15	180	-	252
			1/4"	1 to 2.5	3.5	15	180	-	252
		Universal	1/4"	1.5 to 2.5	3.5	10	180	-	254

### 3 WAY VALVES

# 3/2

## HIGH CORROSION RESISTANT VALVES (303 STAINLESS STEEL) DIRECT OPERATED



Process

### 303 STAINLESS ST. PIPE MOUNTING

#### NORMALLY CLOSED

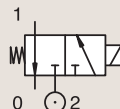

Port size	Orifice Ø		Flow factors				Operating Pressure Differential			Fluid Temp.		Seat Seal	Parker LUCIFER® Valves			IS	Power		Coil Group	Dwg. No.
	1	(2)	1	(2)	1	(2)	Min	Max (MOPD)		Min	Max		Valve Ref.	Housing Ref.	Coil Ref.		AC W	DC W		
								bar	AC bar											
1/4"	1	1	0.6	0.6	0.03	0.03	0	-	10	-10	55	FKM	131V5490	2995	483580.01	*	-	0.5 to 3	7.0/8.0	6740
	1	1	0.6	0.6	0.03	0.03	0	-	10	-10	75	FKM	131V5490	-	488660.01	*	-	0.3 to 3	7.0/8.0	6740
	1	1	0.6	0.6	0.03	0.03	0	-	10	-10	75	FKM	131V5490	-	495910	*	-	0.3 to 3	7.0/8.0	6740
	1.5	1.5	1.5	1.5	0.09	0.09	0	15	15	-10	120	FKM	131V5406	4270	481000		8	8	2.1	8116
	1.5	1.5	1.5	1.5	0.09	0.09	0	15	15	-10	100	FKM	131V5406	2995	481865		8	9	2.1	8116
	1.5	1.5	1.5	1.5	0.09	0.09	0	15	15	0	130	Ruby	131V5463 <sub>1</sub>	4270	481000		8	8	2.0	8116
	1.5	1.5	1.5	1.5	0.09	0.09	0	15	15	0	100	Ruby	131V5463 <sub>1</sub>	2995	481865		8	9	2.0	8116
	1.5	1.5	1.5	1.5	0.09	0.09	0	15	15	0	180	Ruby	131V5463 <sub>1</sub>	4270	486265		14	14	2.0	8116
	1.5	1.5	1.5	1.5	0.09	0.09	0	-	7	-20	75	PUR	131V5497	2995	482740		-	1.6	3.0/6.0/8.0	8024
	1.5	1.5	1.5	1.5	0.09	0.09	0	7	7	-20	75	PUR	131V5497	-	495900		2.5	2	3.0/6.0/8.0	8024
	1.5	1.5	1.5	1.5	0.09	0.09	0	-	7	-20	75	PUR	131V5497	-	495910	*	-	0.3 to 3	3.0/6.0/8.0	8024
	1.5	1.5	1.5	1.5	0.09	0.09	0	-	7	-20	75	PUR	131V5497	2995	496125		-	1.6	3.0/6.0/8.0	8024
	2.5	2.5	3.5	3.5	0.21	0.21	0	7	7	-10	120	FKM	131V5306	4270	481000		8	8	2.1	8116
	2.5	2.5	3.5	3.5	0.21	0.21	0	7	7	-10	100	FKM	131V5306	2995	481865		8	9	2.1	8116
	2.5	2.5	3.5	3.5	0.21	0.21	0	7	7	-30	130	Ruby	131V5363 <sub>1</sub>	4270	481000		8	8	2.0	8116
	2.5	2.5	3.5	3.5	0.21	0.21	0	7	7	-30	100	Ruby	131V5363 <sub>1</sub>	2995	481865		8	9	2.0	8116
	2.5	2.5	3.5	3.5	0.21	0.21	0	7	7	-30	180	Ruby	131V5363 <sub>1</sub>	4270	486265		14	14	2.0	8116
	2.5	2.5	3	3	0.18	0.18	0	-	2	-20	75	PUR	131V5397	2995	482740		-	1.6	6.0/8.0	8024
	2.5	2.5	3	3	0.18	0.18	0	2	2	-20	75	PUR	131V5397	-	495900		2.5	2	6.0/8.0	8024
	2.5	2.5	3	3	0.18	0.18	0	-	2	-20	75	PUR	131V5397	-	495910	*	-	0.3 to 3	6.0/8.0	8024
	2.5	2.5	3	3	0.18	0.18	0	-	2	-20	75	PUR	131V5397	2995	496125		-	1.6	6.0/8.0	8024

**Notes:**

1. Valve only compatible with hydraulic oil and neutral liquids



### 3 WAY VALVES



For this page	Port size	Orifice (mm)	Kv (l/min)	MOPD (bar)	Fluid Temp (°C)	Amb Temp (°C)
From	1/4"	1	0.6	2	-30	-20
To	1/4"	2.5	3.5	15	180	50

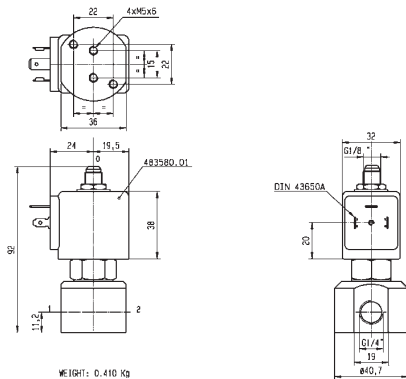

Drawing 6740

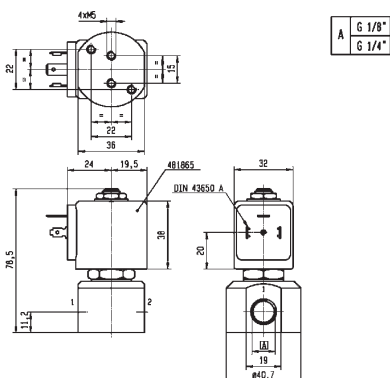

Drawing 8116

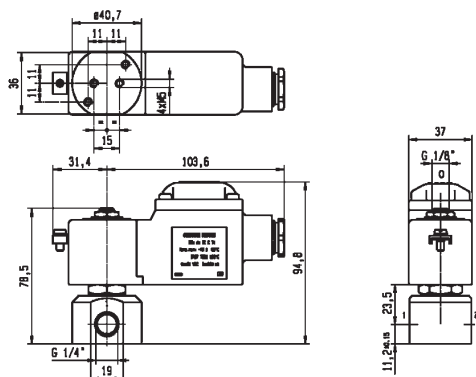

Drawing 8024



### 3 WAY VALVES

# 3/2

## HIGH CORROSION RESISTANT VALVES (303 STAINLESS STEEL) DIRECT OPERATED

303 STAINLESS ST.  
PIPE MOUNTING

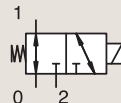

### UNIVERSAL

Port size	Orifice Ø		Flow factors		Operating Pressure Differential			Fluid Temp.		Seat Seal	Parker LUCIFER® Valves			Power		Coil Group	Dwg. No.		
	1	(2)	1	(2)	Min	Max (MOPD)		Min	Max		Valve Ref.	Housing Ref.	Coil Ref.	AC W	DC W				
						bar	AC bar											DC bar	°C
1/4"	1.5	1.5	1.5	1.5	0.09	0.09	0	10	10	-10	120	FKM	133V5406	4270	481000	8	8	2.1	8116
	1.5	1.5	1.5	1.5	0.09	0.09	0	10	10	-10	100	FKM	133V5406	2995	481865	8	9	2.1	8116
	1.5	1.5	1.5	1.5	0.09	0.09	0	10	10	0	130	Ruby	133V5463 <sub>1</sub>	4270	481000	8	8	2.0	8116
	1.5	1.5	1.5	1.5	0.09	0.09	0	4	4	0	100	Ruby	133V5463 <sub>1</sub>	2995	481865	8	9	2.0	8116
	1.5	1.5	1.5	1.5	0.09	0.09	0	10	10	0	180	Ruby	133V5463 <sub>1</sub>	4270	486265	14	14	2.0	8116
	2.5	2.5	3.5	3.5	0.21	0.21	0	4	4	-10	120	FKM	133V5306	4270	481000	8	8	2.1	8116
	2.5	2.5	3.5	3.5	0.21	0.21	0	4	4	0	130	Ruby	133V5363 <sub>1</sub>	4270	481000	8	8	2.0	8116
	2.5	2.5	3.5	3.5	0.21	0.21	0	4	4	0	100	Ruby	133V5363 <sub>1</sub>	2995	481865	8	9	2.0	8116
	2.5	2.5	3.5	3.5	0.21	0.21	0	4	4	0	180	Ruby	133V5363 <sub>1</sub>	4270	486265	14	14	2.0	8116

**Notes:**

1. Valve only compatible with hydraulic oil and neutral liquids



### 3 WAY VALVES



For this page	Port size	Orifice (mm)	Kv (l/min)	MOPD (bar)	Fluid Temp (°C)	Amb Temp (°C)
From	1/4"	1.5	1.5	4	-10	-10
To	1/4"	2.5	3.5	10	180	50

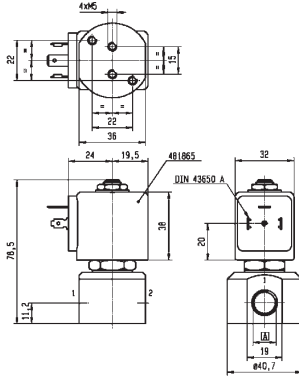

A G 1/8"  
G 1/4"



Drawing 8116

## 3 WAY VALVES



## 3 WAY VALVES



### VALVES FOR BEVERAGE DISPENSING - LIQUIPURE®



# 3/2

Actuation	Body	Function	Port Size	Orifice (mm)	Flow Factor Kv(l/min)	MOPD (bar)	Max Fluid Temp. (°C)	Page Parker Valves
Direct Operated	Stainless St./Sub-base mounting	Normally Closed	SB	1.5 to 3	4.2	14	140	258

### 3 WAY VALVES

# 3/2

## VALVES FOR BEVERAGE DISPENSING - LIQUIPURE® DIRECT OPERATED



Beverage Dispensing



Medical / Instrumentation

### STAINLESS ST. SUB-BASE MOUNTING

#### NORMALLY CLOSED

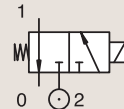

Port size	Orifice Ø		Flow factors		Operating Pressure Differential		Fluid Temp.		Seat Seal	Valve Ref.	Parker Valves		Power		Coil Group	Dwg. No.				
	1	(2)	1	(2)	Min	Max (MOPD)	Min	Max			Housing Ref.	Coil Ref.	AC W	DC W						
BSP	mm		Kv	m <sup>3</sup> /h	bar	AC bar	DC bar	°C	°C											
BSP	1.5	2.5	1.3	-	0.08	-	0	14	14	-10	140	Ruby	3019F1GRG7	-	D4	13	16	24.0	072	
	1.5	2.5	1.3	-	0.08	-	0	14	14	-10	140	Ruby	3019F1GRG7	-	D5	8	9	24.0	072	
	1.5	2.5	1.3	-	0.08	-	0	14	14	-10	140	Ruby	3019F1GRG7	-	LA	9	9	24.0	072	
	1.5	2.5	1.3	-	0.08	-	0	14	14	-10	140	Ruby	3019F1GRG7	-	LB-LC	13	16	24.0	072	
	1.5	2.5	1.3	-	0.08	-	0	14	-	-10	140	Ruby	3019F1GRG7	-	XS03	9	-	24.0	072	
	1.5	2.5	1.3	-	0.08	-	0	14	14	-10	140	FDA FKM	3019F1GVG7	-	D4	13	16	24.0	072	
	1.5	2.5	1.3	-	0.08	-	0	14	14	-10	140	FDA FKM	3019F1GVG7	-	D5	8	9	24.0	072	
	1.5	2.5	1.3	-	0.08	-	0	14	14	-10	140	FDA FKM	3019F1GVG7	-	LA	9	9	24.0	072	
	1.5	2.5	1.3	-	0.08	-	0	14	14	-10	140	FDA FKM	3019F1GVG7	-	LB-LC	13	16	24.0	072	
	1.5	2.5	1.3	-	0.08	-	0	14	-	-10	140	FDA FKM	3019F1GVG7	-	XS03	9	-	24.0	072	
	SB	1.5	2.5	1.3	-	0.08	-	0	14	14	-10	140	Ruby	301XGFRTG7	-	D4	13	16	24.0	073
		1.5	2.5	1.3	-	0.08	-	0	14	14	-10	140	Ruby	301XGFRTG7	-	D5	8	9	24.0	073
		1.5	2.5	1.3	-	0.08	-	0	14	14	-10	140	Ruby	301XGFRTG7	-	LA	9	9	24.0	073
		1.5	2.5	1.3	-	0.08	-	0	14	14	-10	140	Ruby	301XGFRTG7	-	LB-LC	13	16	24.0	073
		1.5	2.5	1.3	-	0.08	-	0	14	-	-10	140	Ruby	301XGFRTG7	-	XS03	9	-	24.0	073
		1.5	2.5	1.3	-	0.08	-	0	14	14	-10	140	FDA FKM	301XGFVTG7	-	D4	13	16	24.0	073
		1.5	2.5	1.3	-	0.08	-	0	14	14	-10	140	FDA FKM	301XGFVTG7	-	D5	8	9	24.0	073
		1.5	2.5	1.3	-	0.08	-	0	14	14	-10	140	FDA FKM	301XGFVTG7	-	LA	9	9	24.0	073
1.5		2.5	1.3	-	0.08	-	0	14	14	-10	140	FDA FKM	301XGFVTG7	-	LB-LC	13	16	24.0	073	
1.5		2.5	1.3	-	0.08	-	0	14	-	-10	140	FDA FKM	301XGFVTG7	-	XS03	9	-	24.0	073	
2		2.5	2.2	-	0.13	-	0	10	10	-10	140	Ruby	3019F1JRG7	-	D4	13	16	24.0	072	
2		2.5	2.2	-	0.13	-	0	10	10	-10	140	Ruby	3019F1JRG7	-	D5	8	9	24.0	072	
2	2.5	2.2	-	0.13	-	0	10	10	-10	140	Ruby	3019F1JRG7	-	LA	9	9	24.0	072		
2	2.5	2.2	-	0.13	-	0	10	10	-10	140	Ruby	3019F1JRG7	-	LB-LC	13	16	24.0	072		



### 3 WAY VALVES



For this page	Port size	Orifice (mm)	Kv (l/min)	MOPD (bar)	Fluid Temp (°C)	Amb Temp (°C)
From	SB	1.5	1.3	10	-10	-10
To	SB	2	2.2	14	140	50

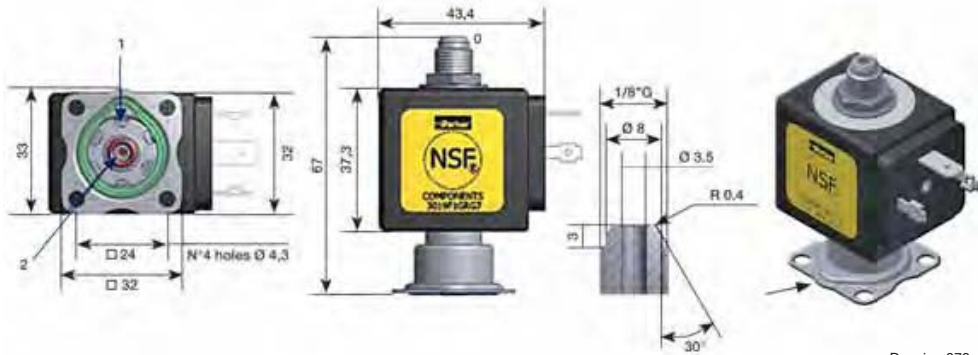

Drawing 072



Drawing 073

### 3 WAY VALVES

# 3/2

## VALVES FOR BEVERAGE DISPENSING - LIQUIPURE® DIRECT OPERATED

STAINLESS ST.  
SUB-BASE MOUNTING

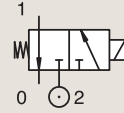

**NORMALLY CLOSED**

Port size	Orifice Ø		Flow factors				Operating Pressure Differential			Fluid Temp.		Seat Seal	Parker Valves			Power		Coil Group	Dwg. No.	
	1	(2)	1	(2)	1	(2)	Min	Max (MOPD)		Min	Max		Valve Ref.	Housing Ref.	Coil Ref.	AC W	DC W			
								bar	AC bar											DC bar
BSP	2	2.5	2.2	-	0.13	-	0	10	-	-10	140	Ruby	3019F1JRG7	-	XS03	9	-	24.0	072	
	2	2.5	2.2	-	0.13	-	0	10	10	-10	140	FDA FKM	3019F1JVG7	-	D4	13	16	24.0	072	
	2	2.5	2.2	-	0.13	-	0	10	10	-10	140	FDA FKM	3019F1JVG7	-	D5	8	9	24.0	072	
	2	2.5	2.2	-	0.13	-	0	10	10	-10	140	FDA FKM	3019F1JVG7	-	LA	9	9	24.0	072	
	2	2.5	2.2	-	0.13	-	0	10	10	-10	140	FDA FKM	3019F1JVG7	-	LB-LC	13	16	24.0	072	
	2	2.5	2.2	-	0.13	-	0	10	-	-10	140	FDA FKM	3019F1JVG7	-	XS03	9	-	24.0	072	
	2	2.5	2.2	-	0.13	-	0	10	10	-10	140	Ruby	301XGFRTJ7	-	D4	13	16	24.0	073	
	2	2.5	2.2	-	0.13	-	0	10	10	-10	140	Ruby	301XGFRTJ7	-	D5	8	9	24.0	073	
	2	2.5	2.2	-	0.13	-	0	10	10	-10	140	Ruby	301XGFRTJ7	-	LA	9	9	24.0	073	
	2	2.5	2.2	-	0.13	-	0	10	10	-10	140	Ruby	301XGFRTJ7	-	LB-LC	13	16	24.0	073	
	2	2.5	2.2	-	0.13	-	0	10	-	-10	140	Ruby	301XGFRTJ7	-	XS03	9	-	24.0	073	
	2	2.5	2.2	-	0.13	-	0	10	10	-10	140	FDA FKM	301XGFVTJ7	-	D4	13	16	24.0	073	
	2	2.5	2.2	-	0.13	-	0	10	10	-10	140	FDA FKM	301XGFVTJ7	-	D5	8	9	24.0	073	
	2	2.5	2.2	-	0.13	-	0	10	10	-10	140	FDA FKM	301XGFVTJ7	-	LA	9	9	24.0	073	
	2	2.5	2.2	-	0.13	-	0	10	10	-10	140	FDA FKM	301XGFVTJ7	-	LB-LC	13	16	24.0	073	
	2	2.5	2.2	-	0.13	-	0	10	-	-10	140	FDA FKM	301XGFVTJ7	-	XS03	9	-	24.0	073	
	SB	2.5	2.5	2.8	-	0.17	-	0	6.5	6.5	-10	140	Ruby	3019F1LRG7	-	D4	13	16	24.0	072
		2.5	2.5	2.8	-	0.17	-	0	6.5	6.5	-10	140	Ruby	3019F1LRG7	-	D5	8	9	24.0	072
		2.5	2.5	2.8	-	0.17	-	0	6.5	6.5	-10	140	Ruby	3019F1LRG7	-	LA	9	9	24.0	072
		2.5	2.5	2.8	-	0.17	-	0	6.5	6.5	-10	140	Ruby	3019F1LRG7	-	LB-LC	13	16	24.0	072
2.5		2.5	2.8	-	0.17	-	0	6.5	-	-10	140	Ruby	3019F1LRG7	-	XS03	9	-	24.0	072	
2.5		2.5	2.8	-	0.17	-	0	6.5	6.5	-10	140	FDA FKM	3019F1LVG7	-	D4	13	16	24.0	072	
2.5		2.5	2.8	-	0.17	-	0	6.5	6.5	-10	140	FDA FKM	3019F1LVG7	-	D5	8	9	24.0	072	
2.5		2.5	2.8	-	0.17	-	0	6.5	6.5	-10	140	FDA FKM	3019F1LVG7	-	LA	9	9	24.0	072	
2.5		2.5	2.8	-	0.17	-	0	6.5	6.5	-10	140	FDA FKM	3019F1LVG7	-	LB-LC	13	16	24.0	072	
2.5		2.5	2.8	-	0.17	-	0	6.5	-	-10	140	FDA FKM	3019F1LVG7	-	XS03	9	-	24.0	072	
2.5		2.5	2.8	-	0.17	-	0	6.5	6.5	-10	140	Ruby	301XGFRTL7	-	D4	13	16	24.0	073	
2.5		2.5	2.8	-	0.17	-	0	6.5	6.5	-10	140	Ruby	301XGFRTL7	-	D5	8	9	24.0	073	
2.5		2.5	2.8	-	0.17	-	0	6.5	6.5	-10	140	Ruby	301XGFRTL7	-	LA	9	9	24.0	073	
2.5		2.5	2.8	-	0.17	-	0	6.5	6.5	-10	140	Ruby	301XGFRTL7	-	LB-LC	13	16	24.0	073	
2.5		2.5	2.8	-	0.17	-	0	6.5	-	-10	140	Ruby	301XGFRTL7	-	XS03	9	-	24.0	073	
2.5		2.5	2.8	-	0.17	-	0	6.5	6.5	-10	140	FDA FKM	301XGFVTL7	-	D4	13	16	24.0	073	
2.5		2.5	2.8	-	0.17	-	0	6.5	6.5	-10	140	FDA FKM	301XGFVTL7	-	D5	8	9	24.0	073	
2.5		2.5	2.8	-	0.17	-	0	6.5	6.5	-10	140	FDA FKM	301XGFVTL7	-	LA	9	9	24.0	073	
2.5		2.5	2.8	-	0.17	-	0	6.5	6.5	-10	140	FDA FKM	301XGFVTL7	-	LB-LC	13	16	24.0	073	



### 3 WAY VALVES



For this page	Port size	Orifice (mm)	Kv (l/min)	MOPD (bar)	Fluid Temp (°C)	Amb Temp (°C)
From	SB	2	2.2	6.5	-10	-10
To	SB	2.5	2.8	10	140	50



Drawing 072



Drawing 073

### 3 WAY VALVES

# 3/2

## VALVES FOR BEVERAGE DISPENSING - LIQUIPURE® DIRECT OPERATED

STAINLESS ST.  
SUB-BASE MOUNTING

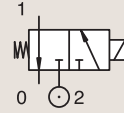

### NORMALLY CLOSED

Port size	Orifice Ø		Flow factors				Operating Pressure Differential			Fluid Temp.		Seat Seal	Parker Valves			Power		Coil Group	Dwg. No.	
	1	(2)	1	(2)	1	(2)	Min	Max (MOPD)		Min	Max		Valve Ref.	Housing Ref.	Coil Ref.	AC W	DC W			
								AC bar	DC bar											°C
BSP	2.5	2.5	2.8	-	0.17	-	0	6.5	-	-10	140	FDA FKM	301XGFVTL7	-	XS03	9	-	24.0	073	
	3	2.5	3.3	-	0.2	-	0	4	4	-10	140	Ruby	3019F1NRG7	-	D4	13	16	24.0	072	
	3	2.5	3.3	-	0.2	-	0	4	4	-10	140	Ruby	3019F1NRG7	-	D5	8	9	24.0	072	
	3	2.5	3.3	-	0.2	-	0	4	4	-10	140	Ruby	3019F1NRG7	-	LA	9	9	24.0	072	
	3	2.5	3.3	-	0.2	-	0	4	4	-10	140	Ruby	3019F1NRG7	-	LB-LC	13	16	24.0	072	
	3	2.5	3.3	-	0.2	-	0	4	-	-10	140	Ruby	3019F1NRG7	-	XS03	9	-	24.0	072	
	3	2.5	3.3	-	0.2	-	0	4	4	-10	140	FDA FKM	3019F1NVG7	-	D4	13	16	24.0	072	
	3	2.5	3.3	-	0.2	-	0	4	4	-10	140	FDA FKM	3019F1NVG7	-	D5	8	9	24.0	072	
	3	2.5	3.3	-	0.2	-	0	4	4	-10	140	FDA FKM	3019F1NVG7	-	LA	9	9	24.0	072	
	3	2.5	3.3	-	0.2	-	0	4	4	-10	140	FDA FKM	3019F1NVG7	-	LB-LC	13	16	24.0	072	
	SB	3	2.5	3.3	-	0.2	-	0	4	-	-10	140	FDA FKM	3019F1NVG7	-	XS03	9	-	24.0	072
		3	2.5	4.2	-	0.25	-	0	4	4	-10	140	Ruby	301XGFRTN7	-	D4	13	16	24.0	073
		3	2.5	4.2	-	0.25	-	0	4	4	-10	140	Ruby	301XGFRTN7	-	D5	8	9	24.0	073
		3	2.5	4.2	-	0.25	-	0	4	4	-10	140	Ruby	301XGFRTN7	-	LA	9	9	24.0	073
		3	2.5	4.2	-	0.25	-	0	4	4	-10	140	Ruby	301XGFRTN7	-	LB-LC	13	16	24.0	073
		3	2.5	4.2	-	0.25	-	0	4	-	-10	140	Ruby	301XGFRTN7	-	XS03	9	-	24.0	073
		3	2.5	4.2	-	0.25	-	0	4	4	-10	140	FDA FKM	301XGFVTN7	-	D4	13	16	24.0	073
		3	2.5	4.2	-	0.25	-	0	4	4	-10	140	FDA FKM	301XGFVTN7	-	D5	8	9	24.0	073
3		2.5	4.2	-	0.25	-	0	4	4	-10	140	FDA FKM	301XGFVTN7	-	LA	9	9	24.0	073	
3		2.5	4.2	-	0.25	-	0	4	4	-10	140	FDA FKM	301XGFVTN7	-	LB-LC	13	16	24.0	073	
3	2.5	4.2	-	0.25	-	0	4	-	-10	140	FDA FKM	301XGFVTN7	-	XS03	9	-	24.0	073		



### 3 WAY VALVES



For this page	Port size	Orifice (mm)	Kv (l/min)	MOPD (bar)	Fluid Temp (°C)	Amb Temp (°C)
From	SB	2.5	2.8	4	-10	-10
To	SB	3	4.2	6.5	140	50



Drawing 073



Drawing 072

## 2 & 3 WAY VALVES FOR TRANSPORTATION

## 2 & 3 WAY VALVES FOR TRANSPORTATION



2 WAY



Water

# 2/2

Actuation	Body	Function	Port Size	Orifice (mm)	Flow Factor Kv(l/min)	MOPD (bar)	Max Fluid Temp. (°C)	Page Parker Valves	Page Parker LUCIFER® Valves
Pilot Operated	Brass/Quick Coupling	Normally Closed	10 mm	11	12	3	90	-	266
	Brass/Barb Fitting	Normally Closed	10 mm	11	12	3	90	-	266
	Brass/Pipe Mounting	Normally Closed	12.7 mm	11	33	3	90	-	268
			15.9 mm	11	36	3	90	-	268

2 & 3 WAY  
VALVES FOR  
TRANSPORTATION

# 2/2

2 WAY  
PILOT OPERATED



Transportation

## BRASS QUICK COUPLING

### NORMALLY CLOSED

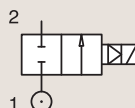

Port size	Orifice Ø mm	Flow factors			Operating Pressure Differential			Fluid Temp.		Seat Seal	Parker LUCIFER® Valves			Voltage	Power		Coil Group	Dwg. No.
		Kv	KV	Qn	Min	Max(MOPD)		Min	Max		Valve Ref.	Housing Ref.	Coil Ref.		AC W	DC W		
		l/min	m³/h	l/min	bar	AC bar	DC bar	°C	°C									
10 mm	11	12	0.72	-	0.2	-	3	-40	90	EPDM	321K1543	2168	495294	12 VDC	-	9	13.0	8242
	11	12	0.72	-	0.2	-	3	-40	90	EPDM	321K1543	2169	495294	24 VDC	-	9	13.0	8242
	11	12	0.72	-	0.2	-	3	-40	90	EPDM	321K1543	2168	496193	12 VDC	-	9	13.0	8242
	11	12	0.72	-	0.2	-	3	-40	90	EPDM	321K1543	2169	496193	24 VDC	-	9	13.0	8242

## BRASS BARB FITTING

### NORMALLY CLOSED

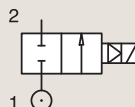

Port size	Orifice Ø mm	Flow factors			Operating Pressure Differential			Fluid Temp.		Seat Seal	Parker LUCIFER® Valves			Voltage	Power		Coil Group	Dwg. No.
		Kv	KV	Qn	Min	Max(MOPD)		Min	Max		Valve Ref.	Housing Ref.	Coil Ref.		AC W	DC W		
		l/min	m³/h	l/min	bar	AC bar	DC bar	°C	°C									
10 mm	11	12	0.72	-	0.2	-	3	-40	90	EPDM	321K1535	2168	495294	12 VDC	-	9	13.0	8241
	11	12	0.72	-	0.2	-	3	-40	90	EPDM	321K1535	2169	495294	24 VDC	-	9	13.0	8241
	11	12	0.72	-	0.2	-	3	-40	90	EPDM	321K1535	2168	496193	12 VDC	-	9	13.0	8241
	11	12	0.72	-	0.2	-	3	-40	90	EPDM	321K1535	2169	496193	24 VDC	-	9	13.0	8241



**2 & 3 WAY  
VALVES FOR  
TRANSPORTATION**

For this page	Port size	Orifice (mm)	Kv (l/min)	MOPD (bar)	Fluid Temp (°C)	Amb Temp (°C)
From	10 mm	11	12	3	-40	-40
To	10 mm	11	12	3	90	80

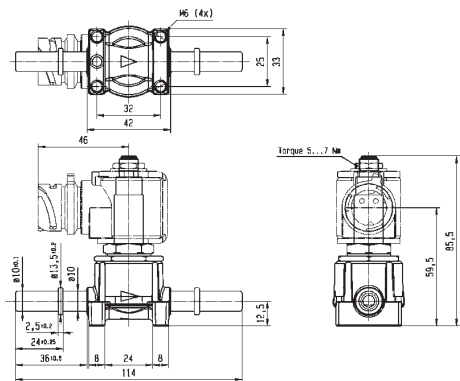

Drawing 8242

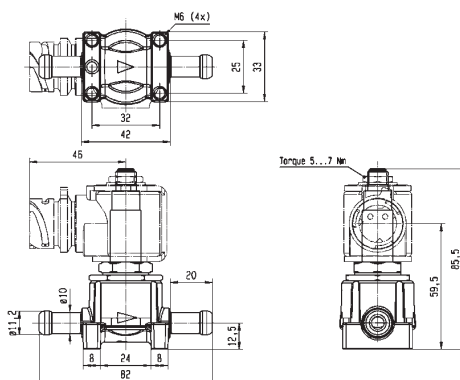

Drawing 8241

# 2/2

2 WAY  
PILOT OPERATED

BRASS  
PIPE MOUNTING

**NORMALLY CLOSED**

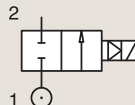

Port size	Orifice Ø mm	Flow factors			Operating Pressure Differential			Fluid Temp.		Seat Seal	Parker LUCIFER® Valves			Voltage	Power		Coil Group	Dwg. No.
					Min bar	Max(MOPD) AC bar	DC bar	Min °C	Max °C		Valve Ref.	Housing Ref.	Coil Ref.		AC W	DC W		
1/2" BSP	11	36	2.16	-	0.2	-	3	-40	90	EPDM	321K1523	2168	495294	12 VDC	-	9	13.0	8238
	11	36	2.16	-	0.2	-	3	-40	90	EPDM	321K1523	2169	495294	24 VDC	-	9	13.0	8238
	11	36	2.16	-	0.2	-	3	-40	90	EPDM	321K1523	2168	496193	12 VDC	-	9	13.0	8238
	11	36	2.16	-	0.2	-	3	-40	90	EPDM	321K1523	2169	496193	24 VDC	-	9	13.0	8238
12.7 mm	11	33	1.98	-	0.2	-	3	-40	90	EPDM	321K1536	2168	495294	12 VDC	-	9	13.0	8282
	11	33	1.98	-	0.2	-	3	-40	90	EPDM	321K1536	2169	495294	24 VDC	-	9	13.0	8282
	11	33	1.98	-	0.2	-	3	-40	90	EPDM	321K1536	2168	496193	12 VDC	-	9	13.0	8282
15.9 mm	11	36	2.16	-	0.2	-	3	-40	90	EPDM	321K1537	2168	495294	12 VDC	-	9	13.0	8281
	11	36	2.16	-	0.2	-	3	-40	90	EPDM	321K1537	2169	495294	24 VDC	-	9	13.0	8281
	11	36	2.16	-	0.2	-	3	-40	90	EPDM	321K1537	2168	496193	12 VDC	-	9	13.0	8281
	11	36	2.16	-	0.2	-	3	-40	90	EPDM	321K1537	2169	496193	24 VDC	-	9	13.0	8281

**2 & 3 WAY  
VALVES FOR  
TRANSPORTATION**

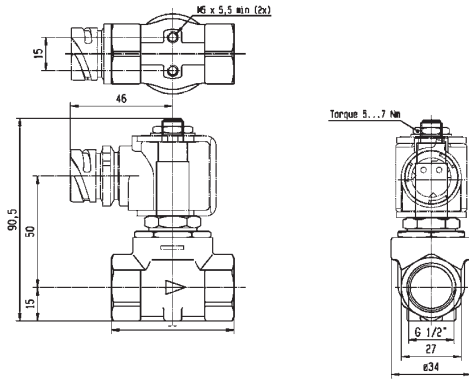

For this page	Port size	Orifice (mm)	Kv (l/min)	MOPD (bar)	Fluid Temp (°C)	Amb Temp (°C)
From	1/2"	11	33	3	-40	-40
To	15.9 mm	11	36	3	90	80

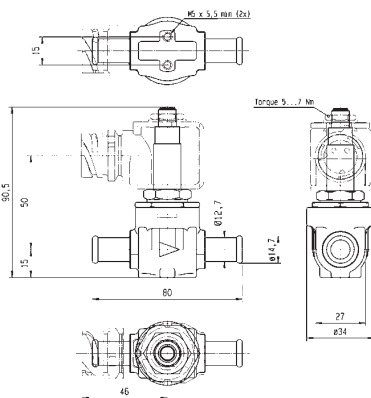

Drawing 8238

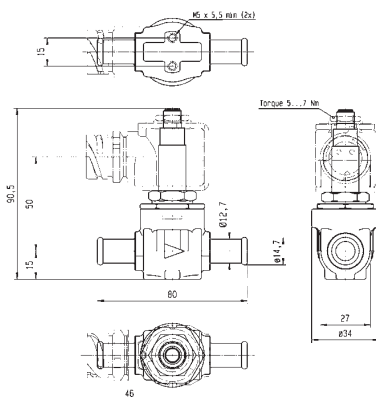

Drawing 8282



Drawing 8281



## 2 & 3 WAY VALVES FOR TRANSPORTATION

## 2 & 3 WAY VALVES FOR TRANSPORTATION



3 WAY



3/2

Actuation	Body	Function	Port Size	Orifice (mm)	Flow Factor Kv(l/min)	MOPD (bar)	Max Fluid Temp. (°C)	Page Parker Valves	Page Parker LUCIFER® Valves
Direct Operated PWM	Brass/Quick Coupling	Normally Closed	1/8"	1.8	0	8	80	-	272

2 & 3 WAY  
VALVES FOR  
TRANSPORTATION

# 3/2

3 WAY  
DIRECT OPERATED PWM



Transportation

BRASS  
QUICK COUPLING

**NORMALLY CLOSED**

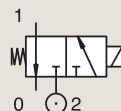

Port size	Orifice Ø		Flow factor Qn l/min	Operating Pressure Differential			Fluid Temp.		Seat Seal	Parker LUCIFER® Valves			Power		Coil Group	Dwg. No.
	1	(2)		Min	Max (MOPD)	Max	Min	Max		Valve Ref.	Housing Ref.	Coil Ref.	AC W	DC W		
BSP	mm			bar	AC bar	DC bar	°C	°C								
1/8"	1.8	1.5	110	0	-	8	-30	80	TPE/PVDF	131K0648 <sub>1</sub>	2161	495294	-	9	13.0	7872
	1.8	1.5	110	0	-	8	-30	80	TPE/PVDF	131K0648 <sub>1</sub>	2161	496193	-	9	13.0	7872

**Notes:**

1. Valve Pulse Width Modulated



**2 & 3 WAY  
VALVES FOR  
TRANSPORTATION**



For this page	Port size	Orifice (mm)	Qn (l/min)	MOPD (bar)	Fluid Temp (°C)	Amb Temp (°C)
From	1/8"	1.8	110	8	-30	-30
To	1/8"	1.8	110	8	80	85

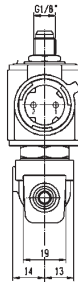
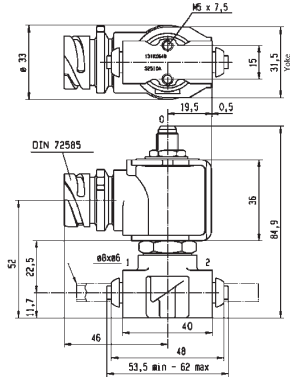

Drawing 7872

## 5 WAY DISTRIBUTORS FOR PNEUMATIC APPLICATIONS

# 5 WAY DISTRIBUTORS FOR PNEUMATIC APPLICATIONS



## 5 WAY PNEUMATIC DISTRIBUTORS (PIPE MOUNTING/SUB-BASE MOUNTING)



# 5/2

Actuation	Body	Function	Port Size	Orifice (mm)	Qn (l/min)	MOPD (bar)	Max Fluid Temp. (°C)	Page Parker Valves	Page Parker LUCIFER® Valves
Pilot Operated	Anodized aluminium/ Pipe mounting	Normally Closed	1/8"-1/4"	6	630	10	75	-	276
			1/4"	6 to 14	2500	40	75	-	276
			1/2"	14	2500	15	75	-	278
		Control by Electric Impulse	1/8"-1/4"	6	630	10	75	-	280
			1/4"	8 to 14	2500	15	75	-	280
			1/8"	4	400	10	75	-	282
	Anodized aluminium/ Pipe mounting/Poppet	Normally Closed	1/8"	4	400	10	75	-	282
		Dual Solenoids	1/8"	4	315	10	75	-	282
	Anodized aluminium/ Sub-base mounting	Normally Closed	1/8"	6	630	10	75	-	284
		Control by Electric Impulse	1/8"	6	630	10	75	-	284
	Anodized aluminium/ Sub-base mounting/ Poppet	Normally Closed	-	15	5000	10	75	-	286
			1/8"	15	5000	10	75	-	286
			4 mm	4	400	10	75	-	286
		Dual Solenoids	4 mm	4	315	10	75	-	288
			Control by Electric Impulse	-	15	5000	10	75	-
Anodized aluminium/ CETOP/Poppet	Dual Solenoids	1/8"	6	800	10	75	-	288	
Anodized aluminium/ Pipe mounting/Poppet	Normally Closed	1/4"	8	1400	10	75	-	290	
	Dual Solenoids	1/4"	8	1400	10	100	-	292	
POM/CETOP/Poppet	Normally Closed	-	6 to 8	800	10	75	-	292	
		1/8"	6	800	10	75	-	294	
	Control by Electric Impulse	1/8"	6	800	10	75	-	296	
Externally Operated	Anodized aluminium/ Sub-base mounting	Normally Closed	1/8"	7	800	10	75	-	298

## 5 WAY VALVES

# 5/2

## 5 WAY PNEUMATIC DISTRIBUTORS (PIPE MOUNTING/SUB-BASE MOUNTING) PILOT OPERATED



Process



Industrial Equipment

### ANODIZED ALUMINIUM PIPE MOUNTING

#### NORMALLY CLOSED

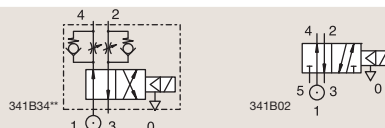

Port size	Orifice Ø	Flow factor	Operating Pressure Differential			Fluid Temp.		Seat Seal	Parker LUCIFER® Valves			IS	Power		Coil Group	Dwg. No.
			Min	Max (MOPD)		Min	Max		Valve Ref.	Housing Ref.	Coil Ref.		AC W	DC W		
BSP	1	Qn l/min	bar	AC bar	DC bar	°C	°C									
1/8" 1/4"	6	630	1	10	10	-10	75	FKM	341B34 <sub>2</sub>	4270	481000		8	8	2.0	3286
	6	630	1	10	10	-10	75	FKM	341B34 <sub>2</sub>	2995	481865		8	9	2.0	3286
	6	630	1	10	10	-10	75	FKM	341B34 <sub>2</sub>	4270	486265		14	14	2.0	3286
	6	630	1	10	10	-10	75	FKM	341B3403	4270	481000		8	8	2.1	3286
	6	630	1	10	10	-10	75	FKM	341B3403	2995	481865		8	9	2.1	3286
	6	560	1	-	10	-10	55	NBR	341B3490	2995	483580.01	*	-	0.5 to 3	7.0/8.0	3561
	6	560	1	-	10	-10	75	NBR	341B3490	-	488660.01	*	-	0.3 to 3	7.0/8.0	3561
1/4"	6	630	1	10	10	-25	75	PUR	341B3440	4270	481000		8	8	2.1	3286
	6	630	1	10	10	-25	75	PUR	341B3440	2995	481865		8	9	2.1	3286
	8	640	1	40	40	-10	75	NBR	341B02 <sub>1</sub>	4270	481000		8	8	2.1	8115
	8	640	1	40	40	-10	75	NBR	341B02 <sub>1</sub>	2995	481865		8	9	2.1	8115

#### Notes:

1. Valve with pilot return pipe on exhaust port
2. With flow regulator



**5 WAY VALVES**

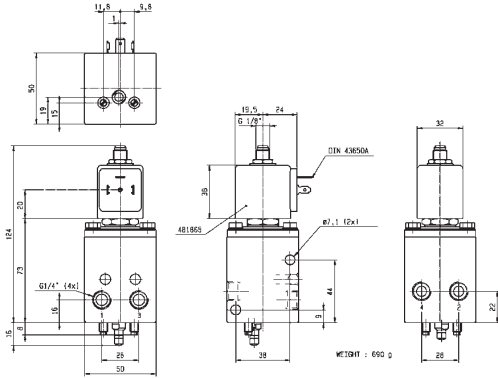

For this page	Port size	Orifice (mm)	Qn (l/min)	MOPD (bar)	Fluid Temp (°C)	Amb Temp (°C)
From	1/8"-1/4"	6	560	10	-25	-25
To	1/4"	8	640	40	75	50

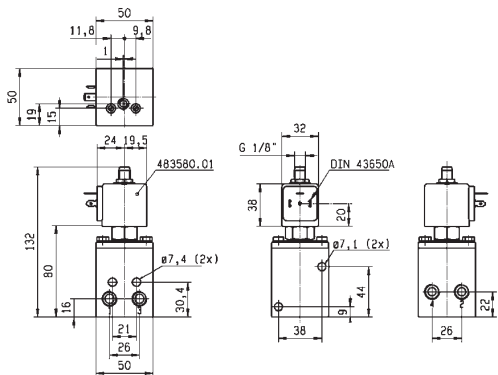

Drawing 3286

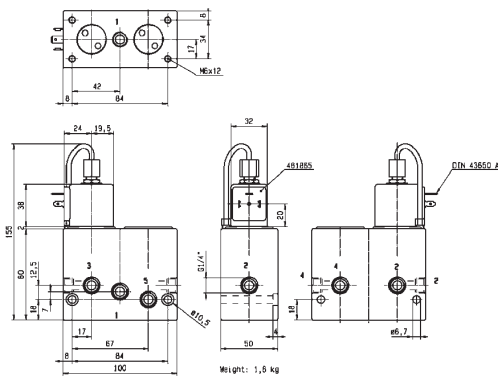

Drawing 3561



Drawing 8115



## 5 WAY VALVES

# 5/2

## 5 WAY PNEUMATIC DISTRIBUTORS (PIPE MOUNTING/SUB-BASE MOUNTING) PILOT OPERATED

ANODIZED ALUMINIUM  
PIPE MOUNTING

**NORMALLY CLOSED**

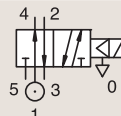

Port size	Orifice Ø	Flow factor	Operating Pressure Differential			Fluid Temp.		Seat Seal	Parker LUCIFER® Valves			Power		Coil Group	Dwg. No.
			Min	Max (MOPD)	DC	Min	Max		Valve Ref.	Housing Ref.	Coil Ref.	AC W	DC W		
BSP	mm	Qn l/min	bar	AC bar	DC bar	°C	°C								
1/4"	8	1000	1	15	15	-10	75	NBR	E341B01	2995	481865	8	9	2.1	3309
	8	1000	1	15	15	-10	75	NBR	E341B01	4270	485100	8	8	2.1	3309
	14	2500	2	15	15	-10	75	NBR	E341F21	4270	481000	8	8	2.1	3310
1/2"	14	2500	1	15	15	-10	75	NBR	E341B21 <sub>1</sub>	2995	481865	8	9	2.1	3315
	14	2500	1	15	15	-10	75	NBR	E341B21 <sub>1</sub>	-	483371	8	8	2.1	3315

**Notes:**

1. Valve only compatible with air and neutral gases

## 5 WAY VALVES



For this page	Port size	Orifice (mm)	Qn (l/min)	MOPD (bar)	Fluid Temp (°C)	Amb Temp (°C)
From	1/4"	8	1000	15	-10	-10
To	1/2"	14	2500	15	75	50

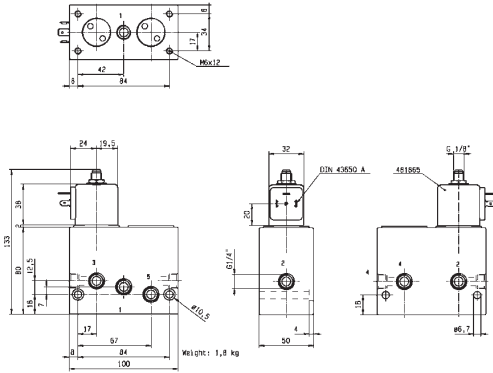

Drawing 3309

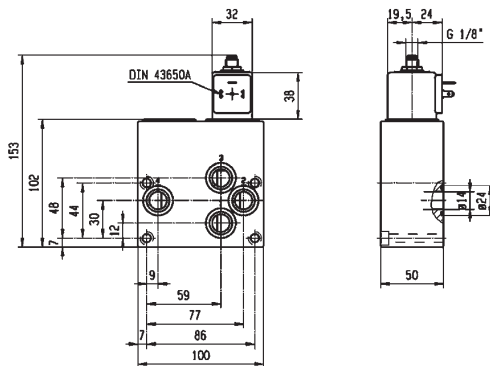

Drawing 3310

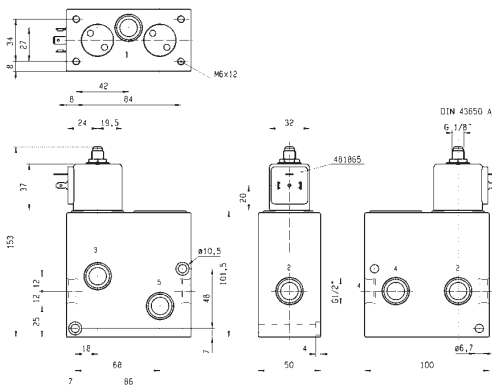

Drawing 3315



**5 WAY VALVES**

# 5/2

## 5 WAY PNEUMATIC DISTRIBUTORS (PIPE MOUNTING/SUB-BASE MOUNTING) PILOT OPERATED

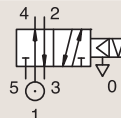
**ANODIZED ALUMINIUM  
PIPE MOUNTING**
**CONTROL BY ELECTRIC IMPULSE**

Port size BSP	Orifice Ø 1 mm	Flow factor Qn l/min	Operating Pressure Differential			Fluid Temp.		Seat Seal	Parker LUCIFER® Valves			Power		Coil Group	Dwg. No.
			Min bar	Max (MOPD) AC bar DC bar		Min °C	Max °C		Valve Ref.	Housing Ref.	Coil Ref.	AC W	DC W		
1/8"- 1/4"	6	630	1	10	-	-10	75	NBR	345B34 <sub>12</sub>	4269	484990	11	-	4.0	3286
	6	630	1	-	10	-10	75	NBR	345B34 <sub>12</sub>	4269	485400	-	13	4.0	3286
1/4"	8	1000	1	15	-	-10	75	NBR	345B04	4269	484990	11	-	4.0	3309
	8	1000	1	-	15	-10	75	NBR	345B04	4269	485400	-	13	4.0	3309
	14	2500	1	15	-	-10	75	NBR	345B24	4269	484990	11	-	4.0	3315
	14	2500	1	-	15	-10	75	NBR	345B24	4269	485400	-	13	4.0	3315

**Notes:**

1. Valve only compatible with air and neutral gases
2. With flow regulator



### 5 WAY VALVES



For this page	Port size	Orifice (mm)	Qn (l/min)	MOPD (bar)	Fluid Temp (°C)	Amb Temp (°C)
From	1/8"-1/4"	6	630	10	-10	-10
To	1/4"	14	2500	15	75	50

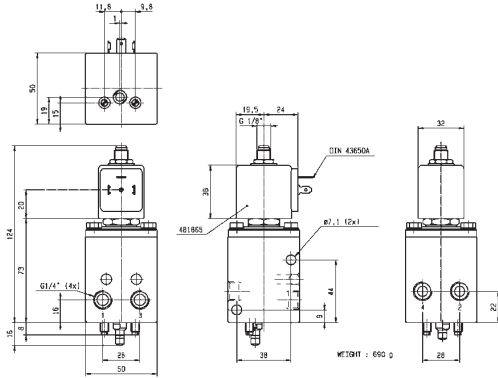

Drawing 3286

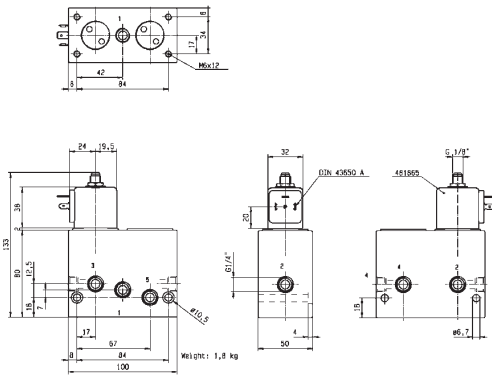

Drawing 3309

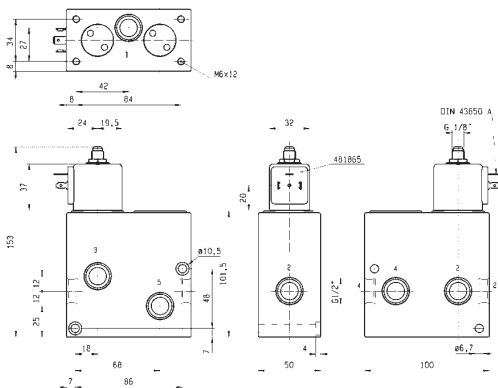

Drawing 3315



## 5 WAY VALVES

# 5/2

## 5 WAY PNEUMATIC DISTRIBUTORS (PIPE MOUNTING/SUB-BASE MOUNTING) PILOT OPERATED

### ANODIZED ALUMINIUM PIPE MOUNTING

#### NORMALLY CLOSED

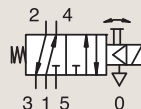

Port size	Orifice Ø	Flow factor	Operating Pressure Differential			Fluid Temp.		Seat Seal	Parker LUCIFER® Valves			Power		Coil Group	Dwg. No.	
			1	Min	Max (MOPD)		Min		Max	Valve Ref.	Housing Ref.	Coil Ref.	AC W			DC W
					AC bar	DC bar										
1/8"	4	400	1	10	10	-10	75	NBR	341L9101 <sub>1</sub>	-	482605	4	5	1.1	3894	
												2	2.5			
												2	2.5			
												2	2.5			

**Notes:**

1. With manual override

### ANODIZED ALUMINIUM PIPE MOUNTING

#### DUAL SOLENOIDS

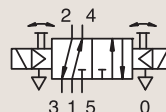

Port size	Orifice Ø	Flow factor	Operating Pressure Differential			Fluid Temp.		Seat Seal	Parker LUCIFER® Valves			Power		Coil Group	Dwg. No.	
			1	Min	Max (MOPD)		Min		Max	Valve Ref.	Housing Ref.	Coil Ref.	AC W			DC W
					AC bar	DC bar										
1/8"	4	315	2	10	10	-10	75	NBR	347L9101 <sub>1</sub>	-	482605	4	5	1.1	3896	
												2	2.5			
												2	2.5			
												2	2.5			

**Notes:**

1. With manual override



### 5 WAY VALVES



For this page	Port size	Orifice (mm)	Qn (l/min)	MOPD (bar)	Fluid Temp (°C)	Amb Temp (°C)
From	1/8"	4	315	10	-10	-10
To	1/8"	4	400	10	75	50

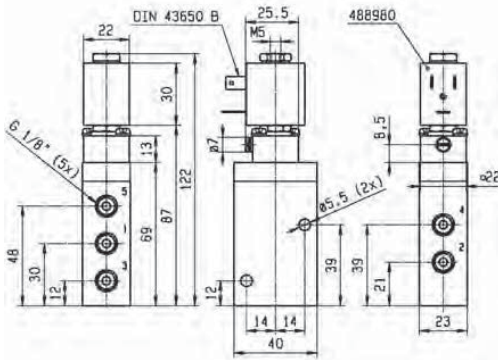

Drawing 3894

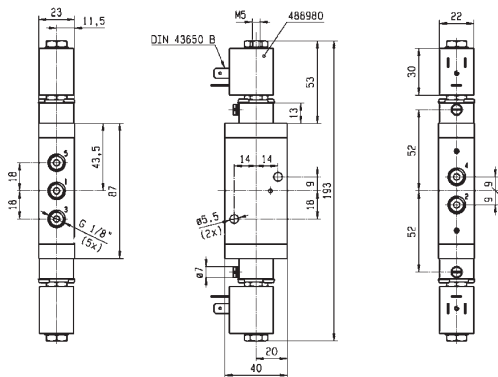

Drawing 3896

## 5 WAY VALVES

# 5/2

## 5 WAY PNEUMATIC DISTRIBUTORS (PIPE MOUNTING/SUB-BASE MOUNTING) PILOT OPERATED

### ANODIZED ALUMINIUM SUB-BASE MOUNTING

#### NORMALLY CLOSED

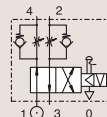

Port size	Orifice Ø 1	Flow factor Qn l/min	Operating Pressure Differential			Fluid Temp.		Seat Seal	Parker LUCIFER® Valves			Power		Coil Group	Dwg. No.
			Min	Max (MOPD)		Min	Max		Valve Ref.	Housing Ref.	Coil Ref.	AC W	DC W		
			bar	AC bar	DC bar	°C	°C								
SB	6	630	1	10	10	-10	75	FKM	341F34 <sub>1</sub>	2995	481865	8	9	2.1	3287
	6	630	1	10	10	-10	75	FKM	341F34 <sub>1</sub>	4270	481000	8	8	2.1	3287
	6	630	1	10	10	-10	75	FKM	341F3403	2995	481865	8	9	2.1	3287
	6	630	1	10	10	-10	75	FKM	341F3403	4270	481000	8	8	2.1	3287
	6	630	1	10	10	-25	75	NBR	341F3440	2995	481865	8	9	2.1	3287

#### Notes:

1. With flow regulator

### ANODIZED ALUMINIUM SUB-BASE MOUNTING

#### CONTROL BY ELECTRIC IMPULSE

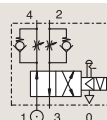





Port size	Orifice Ø 1	Flow factor Qn l/min	Operating Pressure Differential			Fluid Temp.		Seat Seal	Parker LUCIFER® Valves			Power		Coil Group	Dwg. No.
			Min	Max (MOPD)		Min	Max		Valve Ref.	Housing Ref.	Coil Ref.	AC W	DC W		
			bar	AC bar	DC bar	°C	°C								
SB	6	630	1	10	-	-10	75	FKM	345F34 <sub>1</sub>	4269	484990	11	-	4.0	3287
	6	630	1	-	10	-10	75	FKM	345F34 <sub>1</sub>	4269	485400	-	13	4.0	3287

#### Notes:

1. With flow regulator

**5 WAY VALVES**

   	For this page	Port size	Orifice (mm)	Qn (l/min)	MOPD (bar)	Fluid Temp (°C)	Amb Temp (°C)
	From	SB	6	630	10	-25	-25
	To	SB	6	630	10	75	50

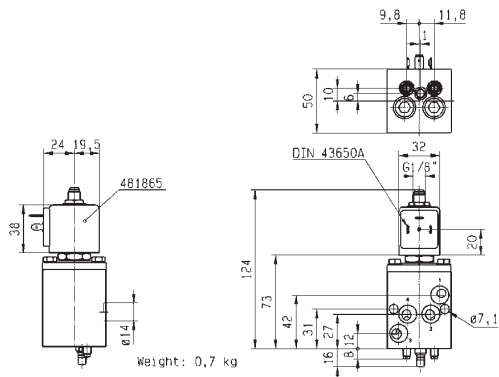

Drawing 3287

## 5 WAY VALVES

# 5/2

## 5 WAY PNEUMATIC DISTRIBUTORS (PIPE MOUNTING/SUB-BASE MOUNTING) PILOT OPERATED

### ANODIZED ALUMINIUM SUB-BASE MOUNTING ISO

#### NORMALLY CLOSED

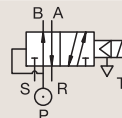

Port size	Orifice Ø 1 mm	Flow factor Qn l/min	Operating Pressure Differential			Fluid Temp.		Seat Seal	Parker LUCIFER® Valves			Power		Coil Group	Dwg. No.	
			Min	Max (MOPD)		Min	Max		Valve Ref.	Housing Ref.	Coil Ref.	IS	DC W			
			bar	AC bar	DC bar	°C	°C									
SB	15	5000	0.5	10	10	-10	75	FKM	E341L21 <sub>1</sub>	2995	481865	8	9	2.1/3.0	3299	
	15	5000	0.5	10	10	-10	75	FKM	E341L21 <sub>1</sub>	-	495905	8	8	2.1/3.0	3299	
	15	5000	0.5	-	10	-10	55	NBR	341L2190 <sub>1</sub>	2995	483580.01	*	-	0.5 to 3	7.0/8.0	8271
	15	5000	0.5	-	10	-10	75	NBR	341L2190 <sub>1</sub>	-	488660.01	*	-	0.3 to 3	7.0/8.0	8271
	15	5000	0.5	-	10	-10	75	NBR	341L2190 <sub>1</sub>	-	495910	*	-	0.3 to 3	7.0/8.0	8271

**Notes:**

1. Valve with manual override

### ANODIZED ALUMINIUM SUB-BASE MOUNTING

#### NORMALLY CLOSED

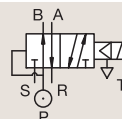

Port size	Orifice Ø 1 mm	Flow factor Qn l/min	Operating Pressure Differential			Fluid Temp.		Seat Seal	Parker LUCIFER® Valves			Power		Coil Group	Dwg. No.
			Min	Max (MOPD)		Min	Max		Valve Ref.	Housing Ref.	Coil Ref.	AC W	DC W		
			bar	AC bar	DC bar	°C	°C								
SB	4	400	1	10	10	-10	75	NBR	341L9201 <sub>1</sub>	-	482605	-	5	1.1	3895
	4	400	1	10	10	-10	75	NBR	341L9201 <sub>1</sub>	-	482606	2	2.5	1.1	3895
	4	400	1	10	10	-10	75	NBR	341L9201 <sub>1</sub>	8993	488980	2	2.5	1.1	3895
	4	400	1	10	10	-10	75	NBR	341L9201 <sub>1</sub>	8993	495865	2	2.5	1.1	3895

**Notes:**

1. Valve with manual override



### 5 WAY VALVES



For this page	Port size	Orifice (mm)	Qn (l/min)	MOPD (bar)	Fluid Temp (°C)	Amb Temp (°C)
From	SB	4	400	10	-10	-10
To	SB	15	5000	10	75	50

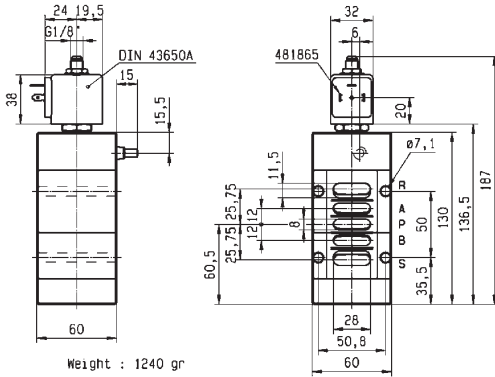

Drawing 3299

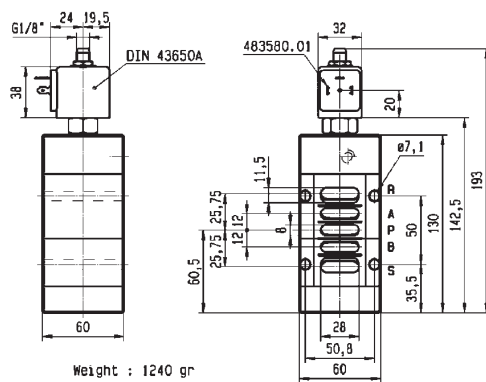

Drawing 8271

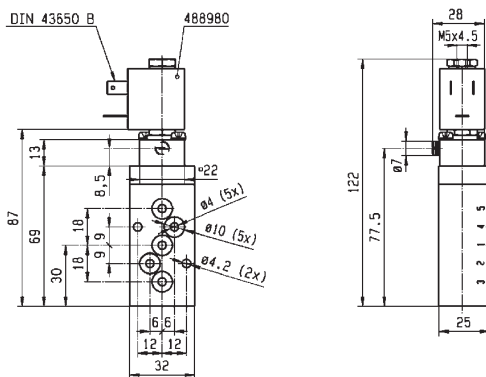

Drawing 3895



**5 WAY VALVES**

# 5/2

## 5 WAY PNEUMATIC DISTRIBUTORS (PIPE MOUNTING/SUB-BASE MOUNTING) PILOT OPERATED

### ANODIZED ALUMINIUM SUB-BASE MOUNTING

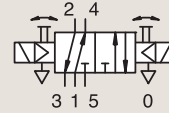

#### DUAL SOLENOIDS

Port size	Orifice Ø 1	Flow factor Qn l/min	Operating Pressure Differential			Fluid Temp.		Seat Seal	Parker LUCIFER® Valves			Power		Coil Group	Dwg. No.
			Min	Max (MOPD)		Min	Max		Valve Ref.	Housing Ref.	Coil Ref.	AC W	DC W		
			bar	AC bar	DC bar	°C	°C								
SB	4	315	2	10	10	-10	75	NBR	347L9201	-	482605	-	5	1.1	3897
	4	315	2	10	10	-10	75	NBR	347L9201	-	482606	2	2.5	1.1	3897
	4	315	2	10	10	-10	75	NBR	347L9201	8993	488980	2	2.5	1.1	3897
	4	315	2	10	10	-10	75	NBR	347L9201	8993	495865	2	2.5	1.1	3897

### ANODIZED ALUMINIUM SUB-BASE MOUNTING

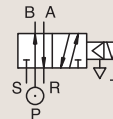

#### CONTROL BY ELECTRIC IMPULSE

Port size	Orifice Ø 1	Flow factor Qn l/min	Operating Pressure Differential			Fluid Temp.		Seat Seal	Parker LUCIFER® Valves			Power		Coil Group	Dwg. No.
			Min	Max (MOPD)		Min	Max		Valve Ref.	Housing Ref.	Coil Ref.	AC W	DC W		
			bar	AC bar	DC bar	°C	°C								
SB	15	5000	0.5	10	-	-10	75	NBR	345L21	4269	484990	11	-	4.0	3299
	15	5000	0.5	-	10	-10	75	NBR	345L21	4269	485400	-	13	4.0	3299

### ANODIZED ALUMINIUM CETOP

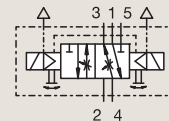

#### DUAL SOLENOIDS

Port size	Orifice Ø 1	Flow factor Qn l/min	Operating Pressure Differential			Fluid Temp.		Seat Seal	Parker LUCIFER® Valves			Power		Coil Group	Dwg. No.
			Min	Max (MOPD)		Min	Max		Valve Ref.	Housing Ref.	Coil Ref.	AC W	DC W		
			bar	AC bar	DC bar	°C	°C								
BSP 1/8"	6	800	1	10	10	-10	75	NBR	347L04	8993	488980	2	2.5	1.1	3694

### 5 WAY VALVES



For this page	Port size	Orifice (mm)	Qn (l/min)	MOPD (bar)	Fluid Temp (°C)	Amb Temp (°C)
From	SB	4	315	10	-10	-10
To	4 mm	15	5000	10	75	50

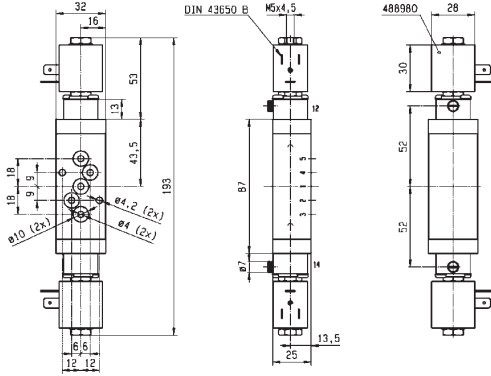

Drawing 3897

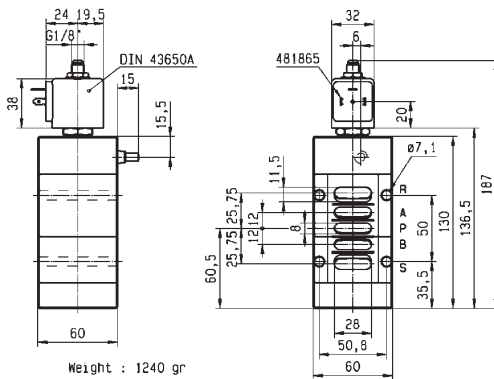

Weight : 1240 gr



Drawing 3299

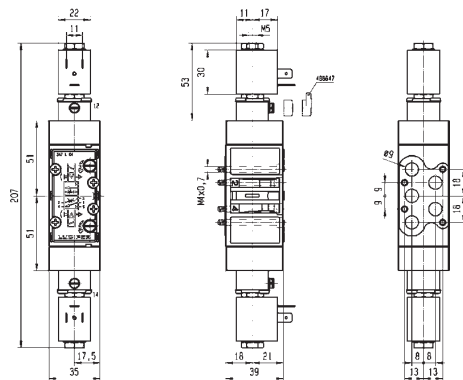

Drawing 3694



## 5 WAY VALVES

# 5/2

## 5 WAY PNEUMATIC DISTRIBUTORS (PIPE MOUNTING/SUB-BASE MOUNTING) PILOT OPERATED

### ANODIZED ALUMINIUM PIPE MOUNTING

#### NORMALLY CLOSED

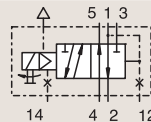

Port size	Orifice Ø	Flow factor	Operating Pressure Differential			Fluid Temp.		Seat Seal	Parker LUCIFER® Valves			Power		Coil Group	Dwg. No.
			Min	Max (MOPD)	DC	Min	Max		Valve Ref.	Housing Ref.	Coil Ref.	AC W	DC W		
BSP	mm	Qn l/min	bar	AC bar	DC bar	°C	°C								
1/4"	8	1400	1	10	10	-10	75	NBR	341L11	-	482605	4	5	1.1	3434
	8	1400	1	10	10	-10	75	NBR	341L11	-	482606	2	2.5	1.1	3434
	8	1400	1	10	10	-10	75	NBR	341L11	8993	488980	2	2.5	1.1	3434
	8	1400	1	10	10	-10	75	NBR	341L11	8993	495865	2	2.5	1.1	3434
	8	1400	1	10	10	-10	75	NBR	E341L1130	2995	481865	8	9	2.1/3.0	3539
	8	1400	1	10	10	-10	75	NBR	E341L1130	-	483371	8	8	2.1/3.0	3539
1/4" NPT	8	1400	1	10	10	-10	75	FKM	U341L1130	2995	481865	8	9	2.1	8297
	8	1400	1	10	10	-10	75	FKM	U341L1130	2995	491514	11	12	2.1	8297



### 5 WAY VALVES



For this page	Port size	Orifice (mm)	Qn (l/min)	MOPD (bar)	Fluid Temp (°C)	Amb Temp (°C)
From	1/4"	8	1400	10	-10	-10
To	1/4"	8	1400	10	75	50

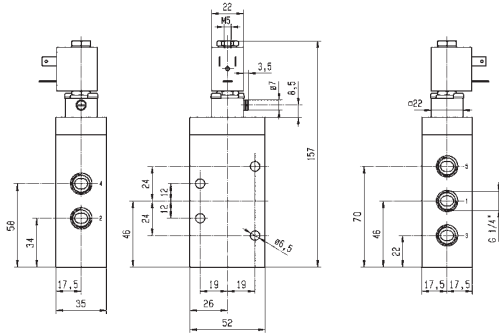

Drawing 3434

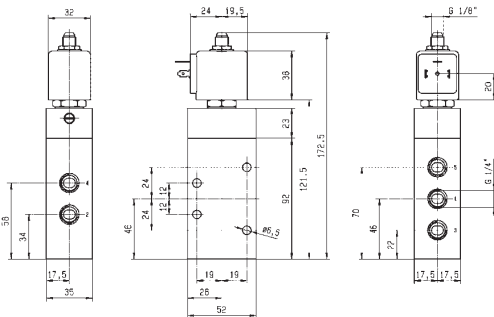

Drawing 3539

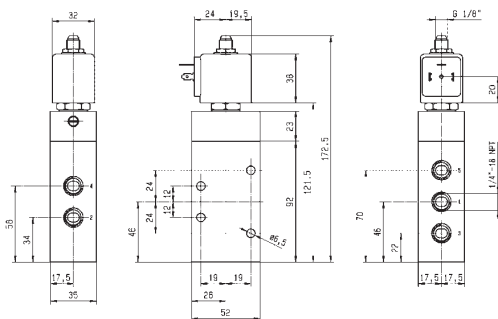

Drawing 8297



## 5 WAY VALVES

# 5/2

## 5 WAY PNEUMATIC DISTRIBUTORS (PIPE MOUNTING/SUB-BASE MOUNTING) PILOT OPERATED

### ANODIZED ALUMINIUM PIPE MOUNTING

#### DUAL SOLENOIDS

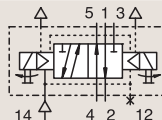

Port size	Orifice Ø	Flow factor	Operating Pressure Differential			Fluid Temp.		Seat Seal	Parker LUCIFER® Valves			Power		Coil Group	Dwg. No.	
			1	Min	Max (MOPD)		Min		Max	Valve Ref.	Housing Ref.	Coil Ref.	AC W			DC W
					AC bar	DC bar										
1/4"	8	1400	1	10	10	-10	75	NBR	347L11 <sub>1</sub>	-	482605	4	5	1.1	3461	
	8	1400	1	10	10	-10	75	NBR	347L11 <sub>1</sub>	-	482606	2	2.5	1.1	3461	
	8	1400	1	10	10	-10	75	NBR	347L11 <sub>1</sub>	8993	488980	2	2.5	1.1	3461	
	8	1400	1	10	10	-10	75	NBR	347L11 <sub>1</sub>	8993	495865	2	2.5	1.1	3461	
	8	1400	2	10	10	-10	100	FKM	E347L1130 <sub>1</sub>	2995	481865	8	9	2.1/3.0	3541	
	8	1400	2	10	10	-10	100	FKM	E347L1130 <sub>1</sub>	4270	481000	8	8	2.1/3.0	3541	

#### Notes:

1. With manual override

### POM CETOP

#### NORMALLY CLOSED

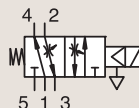

Port size	Orifice Ø	Flow factor	Operating Pressure Differential			Fluid Temp.		Seat Seal	Parker LUCIFER® Valves			Power		Coil Group	Dwg. No.	
			1	Min	Max (MOPD)		Min		Max	Valve Ref.	Housing Ref.	Coil Ref.	AC W			DC W
					AC bar	DC bar										
-	6	800	1	10	10	-10	75	FKM	E341L02	2995	481865	8	9	2.1/3.0	3513	
	6	800	1	10	10	-10	75	FKM	E341L02	4270	481000	8	8	2.1/3.0	3513	

### 5 WAY VALVES



For this page	Port size	Orifice (mm)	Qn (l/min)	MOPD (bar)	Fluid Temp (°C)	Amb Temp (°C)
From	1/4"	6	800	10	-10	-10
To	1/4"	8	1400	10	100	50

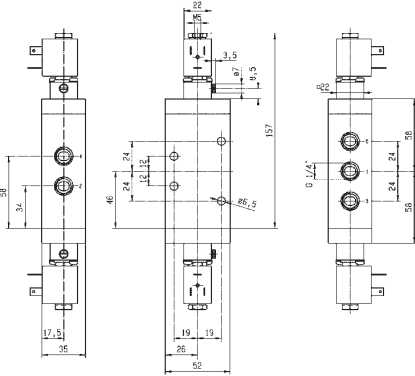

Drawing 3461

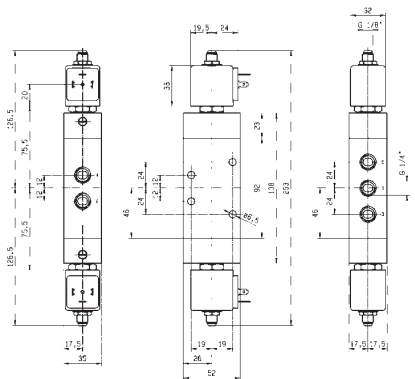

Drawing 3541

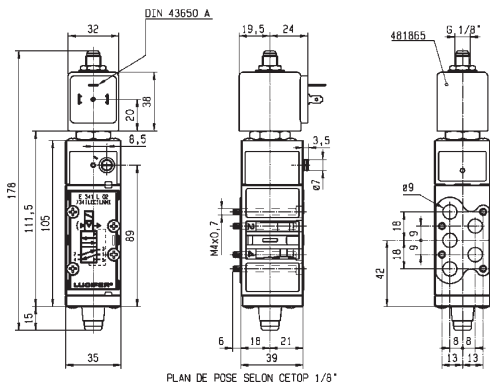

Drawing 3513



5 WAY VALVES

# 5/2

## 5 WAY PNEUMATIC DISTRIBUTORS (PIPE MOUNTING/SUB-BASE MOUNTING) PILOT OPERATED

POM  
CETOP

**NORMALLY CLOSED**

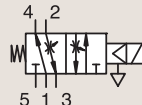

Port size	Orifice Ø	Flow factor	Operating Pressure Differential			Fluid Temp.		Seat Seal	Parker LUCIFER® Valves			Power		Coil Group	Dwg. No.
			Min	Max (MOPD)	DC bar	Min	Max		Valve Ref.	Housing Ref.	Coil Ref.	AC W	DC W		
-	8	800	1	10	10	-10	75	FKM	341L04 <sub>1</sub>	-	482605	4	5	1.1	3437
	8	800	1	10	10	-10	75	FKM	341L04 <sub>1</sub>	-	482606	2	2.5	1.1	3437
	8	800	1	10	10	-10	75	FKM	341L04 <sub>1</sub>	8993	488980	2	2.5	1.1	3437
	8	800	1	10	10	-10	75	FKM	341L04 <sub>1</sub>	8993	495865	2	2.5	1.1	3437
1/8"	6	800	1	-	10	-10	75	NBR	341L0197	2995	482740	-	1.6	6.0/8.0	8021
	6	800	1	10	10	-10	75	NBR	341L0197	-	495900	2.5	2	6.0/8.0	8021
	6	800	1	-	10	-10	75	NBR	341L0197	-	495910	-	0.3 to 3	6.0/8.0	8021
	6	800	1	-	10	-10	75	NBR	341L0197	2995	496125	-	1.6	6.0/8.0	8021
	6	800	1	10	10	-10	75	NBR	341L05 <sub>2</sub>	-	482605	4	5	1.1	3430
	6	800	1	10	10	-10	75	NBR	341L05 <sub>2</sub>	-	482606	2	2.5	1.1	3430
	6	800	1	10	10	-10	75	NBR	341L05 <sub>2</sub>	8993	488980	2	2.5	1.1	3430
	6	800	1	10	10	-10	75	NBR	341L05 <sub>2</sub>	8993	495865	2	2.5	1.1	3430
	6	800	1	10	-	-10	75	FKM	E341L01 <sub>1</sub>	2995	482722	10	-	2.1/3.0	3255
	6	800	1	10	10	-10	75	FKM	E341L01 <sub>1</sub>	-	483371	8	8	2.1/3.0	3255
	6	800	1	10	10	-10	75	FKM	E341L01 <sub>1</sub>	2995.33	491514	11	12	2.1/3.0	3255

**Notes:**

1. Manual override and flow regulating screws standard
2. With manual override

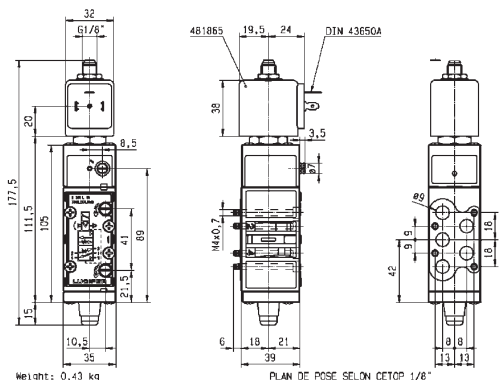

Drawing 3255



### 5 WAY VALVES



For this page	Port size	Orifice (mm)	Qn (l/min)	MOPD (bar)	Fluid Temp (°C)	Amb Temp (°C)
From	1/8"	6	800	10	-10	-20
To	1/8"	8	800	10	75	50

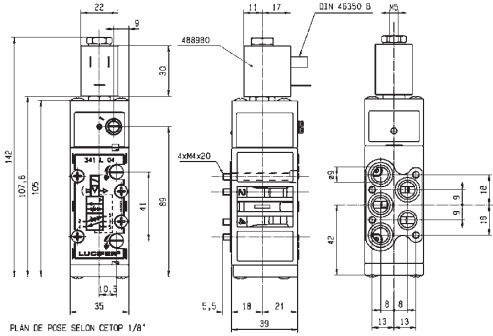

Drawing 3437

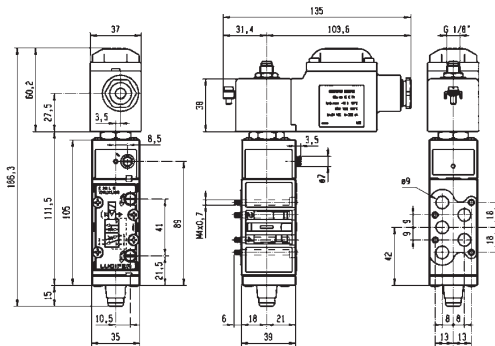

Drawing 8021

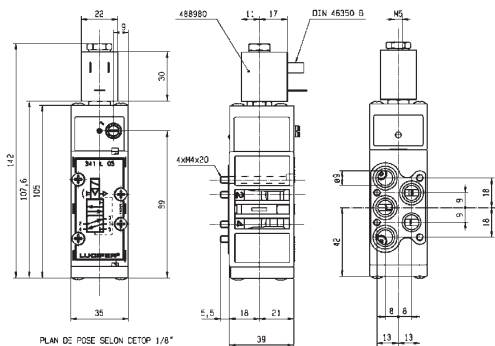

Drawing 3430



5 WAY VALVES

# 5/2

5 WAY PNEUMATIC DISTRIBUTORS  
(PIPE MOUNTING/SUB-BASE MOUNTING)  
PILOT OPERATED

POM  
CETOP

**CONTROL BY ELECTRIC IMPULSE**

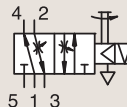

Port size BSP	Orifice Ø mm	Flow factor Qn l/min	Operating Pressure Differential			Fluid Temp.		Seat Seal	Valve Ref.	Parker LUCIFER® Valves			Power		Coil Group	Dwg. No.
			Min bar	Max (MOPD) AC bar DC bar	Min °C	Max °C	Housing Ref.			Coil Ref.	AC W	DC W				
1/8"	6	800	1	- 10	-10 75	FKM	345L01 <sub>1</sub>	4269	485400	-	13	4.0	3255			

**Notes:**

1. Manual override and flow regulating screws standard



### 5 WAY VALVES



For this page	Port size	Orifice (mm)	Qn (l/min)	MOPD (bar)	Fluid Temp (°C)	Amb Temp (°C)
From	1/8"	6	800	10	-10	-10
To	1/8"	6	800	10	75	50

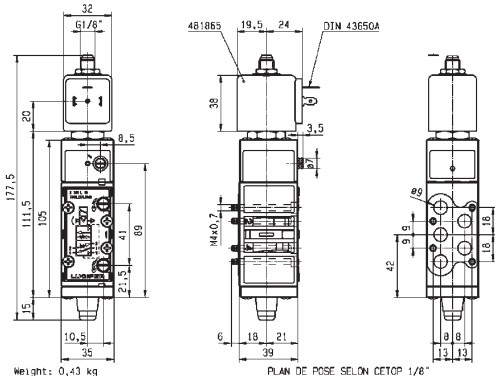

Drawing 3255

5 WAY VALVES

# 5/2

## 5 WAY PNEUMATIC DISTRIBUTORS (PIPE MOUNTING/SUB-BASE MOUNTING) EXTERNALLY OPERATED



Process



Industrial Equipment

POM  
SUB-BASE MOUNTING

**NORMALLY CLOSED**

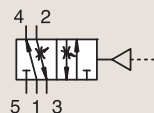

Port size	Orifice Ø 1 mm	Flow factor Qn l/min	Operating Pressure Differential			Fluid Temp.		Seat Seal FKM/ NBR	Parker LUCIFER® Valves			Power		Coil Group	Dwg. No.
			Min bar	Max (MOPD) AC bar	DC bar	Min °C	Max °C		Valve Ref.	Housing Ref.	Coil Ref.	AC W	DC W		
SB	7	800	1	10	10	-10	75		541L01	-	-	-	-	-	3254



### 5 WAY VALVES



For this page	Port size	Orifice (mm)	Qn (l/min)	MOPD (bar)	Fluid Temp (°C)	Amb Temp (°C)
From	1/8"	7	800	10	-10	-10
To	1/8"	7	800	10	75	50

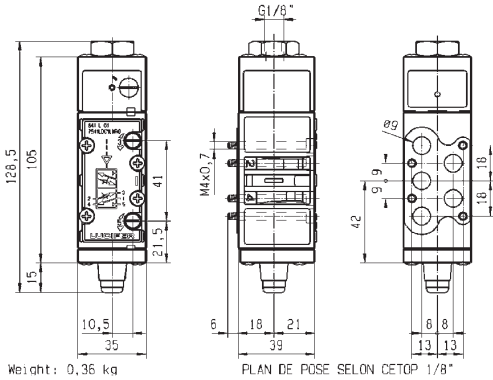

Weight: 0.36 kg

PLAN DE POSE SELON CETOP 1/8"



Drawing 3254

## 3 & 5 WAY PNEUMATIC DISTRIBUTORS FOR ACTUATION CONTROL

## 3 & 5 WAY PNEUMATIC DISTRIBUTORS FOR ACTUATION CONTROL



### 3 & 5 WAY PNEUMATIC VALVES FOR ACTUATOR CONTROL (PIPE MOUNTING)



**3/2**  
**5/2**

Actuation	Body	Function	Port Size	Orifice (mm)	Qn (l/min)	MOPD (bar)	Max Fluid Temp. (°C)	Page Parker Valves	Page Parker LUCIFER® Valves
Direct Operated	Brass/Pipe mounting	Normally Closed	1/8"	1.2 to 1.5	70	10	75	-	302
			1/8"-1/4"	2.5	220	7	75	-	302
			1/4"	1 to 4.5	500	16	120	-	302
		Normally Open	1/4"	2.5	220	7	75	-	308
		Universal	1/4"	6	680	10	75	-	308
		Control by Electric Impulse	1/4"	2.5	220	7	100	-	310
	Brass/Sub-base mounting	Normally Closed	5 mm	2.5	180	2	75	-	312
		Universal	1/8"	2	140	7	120	-	312
		Universal	1/4"	6	680	10	80	-	314
		Universal	1/4"	6	680	10	80	-	314
Pilot Operated	Anodized aluminium/ Pipe mounting/Spool	Normally Closed	1/8"	4 to 15	600	10	80	-	316
			1/4"	7 to 8	1400	10	80	-	318
			1/2"	12	3000	10	50	-	322
		Dual Solenoids	1/8"	4	400	10	80	-	324
			1/4"	7 to 8	1400	10	80	-	326
			1/2"	12	3000	10	50	-	328
		Control by Electric Impulse	1/8"	4	600	10	80	-	328
		Manual Reset	Brass/Pipe mounting	Universal	1/4"	6	680	10	65

### 3 & 5 WAY PNEUMATIC DISTRIBUTORS

# 3/2

## 3 & 5 WAY PNEUMATIC VALVES FOR ACTUATOR CONTROL (PIPE MOUNTING) DIRECT OPERATED



Commercial Equipment



Industrial Equipment



Process

### BRASS PIPE MOUNTING

#### NORMALLY CLOSED

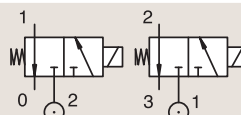

Port size	Orifice Ø	Flow factor	Operating Pressure Differential			Fluid Temp.		Seat Seal	Parker LUCIFER® Valves			ATEX Zone	Protection Mode	Power		Coil Group	Dwg. No.
			Min	Max (MOPD)		Min	Max		Valve Ref.	Housing Ref.	Coil Ref.			AC W	DC W		
BSP	mm	Qn l/min	bar	AC bar	DC bar	°C	°C										
1/8"	1.2	50	0	10	10	-10	75	FKM	131M15	8993	488980	-	-	2	2.5	1.1	3382
	1.5	70	0	7	7	-10	75	FKM	131M14	8993	488980	-	-	2	2.5	1.1	3382
1/8"-1/4"	2.5	220	0	7	7	-40	75	PUR	E131K0358 <sub>1</sub>	2995	481865	-	-	8	9	2.1	3510
	2.5	220	0	7	7	-40	75	PUR	E131K0358 <sub>1</sub>	4270	481000	-	-	8	8	2.1	3510
1/4"	1	36	0	-	10	-10	55	FKM	131K0490	2995	483580.01	0-20	Ex ia IIC T6	-	0.5 to 3	7.0/8.0	7058
	1	36	0	-	10	-10	75	FKM	131K0490	-	488660.01	0-20	Ex ia IIC T6	-	0.3 to 3	7.0/8.0	7058
	1	36	0	-	10	-10	75	FKM	131K0490	-	495910	0-20	Ex ia IIC T4 to T6	-	0.3 to 3	7.0/8.0	7058

**Notes:**

1. With manual override



### 3 & 5 WAY PNEUMATIC DISTRIBUTORS



For this page	Port size	Orifice (mm)	Qn (l/min)	MOPD (bar)	Fluid Temp (°C)	Amb Temp (°C)
From	1/8"	1	36	7	-40	-40
To	1/4"	2.5	220	10	75	50

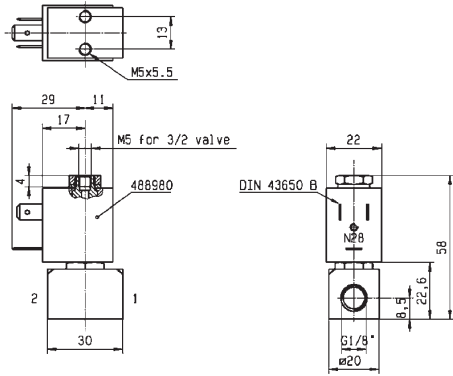

Drawing 3382

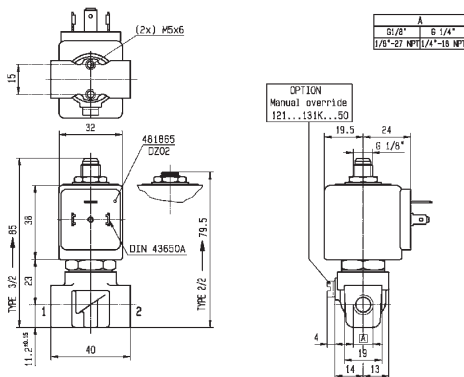

Drawing 3510

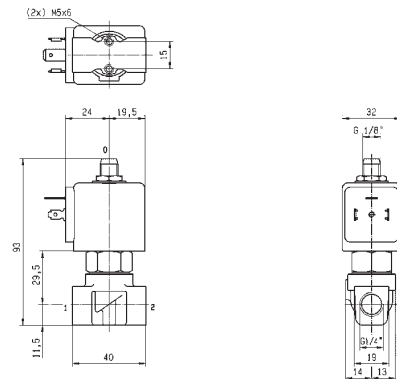

Drawing 7058



**3 & 5 WAY  
PNEUMATIC  
DISTRIBUTORS**

# 3/2

## 3 & 5 WAY PNEUMATIC VALVES FOR ACTUATOR CONTROL (PIPE MOUNTING) DIRECT OPERATED

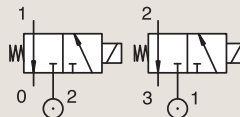
**BRASS**
**PIPE MOUNTING**
**NORMALLY CLOSED**

Port size	Orifice Ø	Flow factor	Operating Pressure Differential			Fluid Temp.		Seat Seal	Parker LUCIFER® Valves			ATEX Zone	Protection Mode	Power		Coil Group	Dwg. No.
			Min	Max (MOPD)	AC bar	DC bar	Min		Max	Valve Ref.	Housing Ref.			Coil Ref.	AC W		
1/4"	1.5	80	0	-	7	-20	75	PUR	131K0497	2995	482740	-	-	-	1.6	6.0/8.0	8023
	1.5	80	0	7	7	-20	75	PUR	131K0497	-	495900	1-21	Ex db mb IIC T4 to T6	2.5	2	6.0/8.0	8023
	1.5	80	0	-	7	-20	75	PUR	131K0497	-	495910	0-20	Ex ia IIC T4 to T6	-	0.3 to 3	6.0/8.0	8023
	1.5	80	0	-	7	-20	75	PUR	131K0497	2995	496125	2-22	Ex nAc nCc IIC T5/T6	-	1.6	6.0/8.0	8023
	1.5	80	0	16	16	-10	100	FKM	E131K04	2995	481865	-	-	8	9	2.0	3510
	1.5	80	0	16	16	-10	120	FKM	E131K04	4270	481000	-	-	8	8	2.0	3510
	1.5	80	0	16	16	-10	120	FKM	E131K04	4270	486265	-	-	14	14	2.0	3510
	1.5	80	0	15	15	-10	100	FKM	E131K0450 <sub>1</sub>	2995	481865	-	-	8	9	2.1	3510
	1.5	80	0	15	15	-10	120	FKM	E131K0450 <sub>1</sub>	4270	481000	-	-	8	8	2.1	3510
	2	140	0	10	10	-10	100	FKM	E131K06	2995	481865	-	-	8	9	2.0	8119
	2	140	0	10	10	-10	120	FKM	E131K06	4270	481000	-	-	8	8	2.0	8119
	2	140	0	10	10	-10	120	FKM	E131K06	4270	486265	-	-	14	14	2.0	8119
2	140	0	10	10	-10	100	FKM	E131K0650 <sub>1</sub>	2995	481865	-	-	8	9	2.1	3510	
2	140	0	10	10	-10	120	FKM	E131K0650 <sub>1</sub>	4270	481000	-	-	8	8	2.1	3510	

**Notes:**

1. With manual override



### 3 & 5 WAY PNEUMATIC DISTRIBUTORS



For this page	Port size	Orifice (mm)	Qn (l/min)	MOPD (bar)	Fluid Temp (°C)	Amb Temp (°C)
From	1/4"	1.5	80	7	-20	-20
To	1/4"	2	140	16	120	50

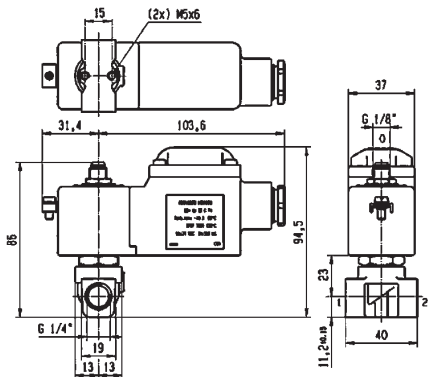

Drawing 8023

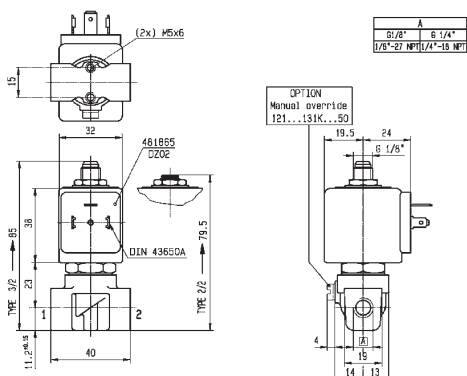

Drawing 3510

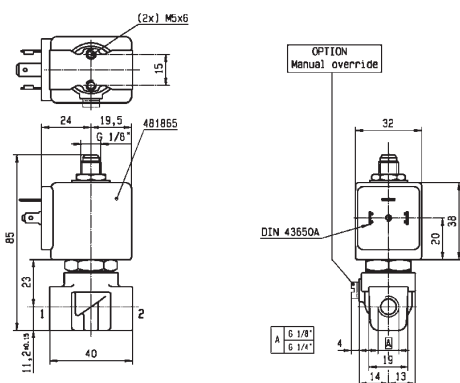

Drawing 8119

### 3 & 5 WAY PNEUMATIC DISTRIBUTORS

# 3/2

## 3 & 5 WAY PNEUMATIC VALVES FOR ACTUATOR CONTROL (PIPE MOUNTING) DIRECT OPERATED

BRASS

PIPE MOUNTING

**NORMALLY CLOSED**

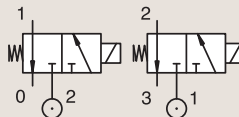

Port size	Orifice Ø	Flow factor	Operating Pressure Differential			Fluid Temp.		Seat Seal	Parker LUCIFER® Valves			ATEX Zone	Protection Mode	Power		Coil Group	Dwg. No.
			Min	Max (MOPD)	AC bar	DC bar	Min		Max	Valve Ref.	Housing Ref.			Coil Ref.	AC W		
1/4"	2.5	220	0.1	7	7	-10	75	FKM	E131E03	2995	481865	-	-	8	9	2.0	3525
	2.5	220	0.1	7	7	-10	75	FKM	E131E03	4270	481000	-	-	8	8	2.0	3525
	2.5	220	0.1	7	7	-10	75	FKM	E131E03	4270	486265	-	-	14	14	2.0	3525
	2.5	220	0	7	7	-40	75	PUR	E131K0308	2995	481865	-	-	8	9	2.1	3510
	2.5	220	0	7	7	-40	75	PUR	E131K0308	4270	481000	-	-	8	8	2.1	3510
	2.5	220	0	7	7	-10	100	FKM	E131K0350 <sub>1</sub>	2995	481865	-	-	8	9	2.1	3510
	2.5	220	0	7	7	-10	120	FKM	E131K0350 <sub>1</sub>	4270	481000	-	-	8	8	2.1	3510
	4.5	500	0	2	2	-10	75	FKM	131T2101 <sub>1</sub>	2995	481865	-	-	8	9	2.1	3223
4.5	500	0	2	2	-10	75	FKM	131T2101 <sub>1</sub>	4270	481000	-	-	8	8	2.1	3223	

**Notes:**

1. With manual override





### 3 & 5 WAY PNEUMATIC DISTRIBUTORS

# 3/2

## 3 & 5 WAY PNEUMATIC VALVES FOR ACTUATOR CONTROL (PIPE MOUNTING) DIRECT OPERATED

BRASS

PIPE MOUNTING

**NORMALLY OPEN**

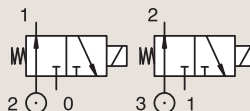

Port size	Orifice Ø	Flow factor	Operating Pressure Differential			Fluid Temp.		Seat Seal	Parker LUCIFER® Valves			ATEX Zone	Protection Mode	Power		Coil Group	Dwg. No.
			Min	Max (MOPD)	Min	Max	Valve Ref.		Housing Ref.	Coil Ref.	AC W			DC W			
BSP	mm	Qn l/min	bar	AC bar	DC bar	°C	°C										
1/4"	2.5	220	0	7	3.5	-10	75	FKM	132T29	2995	481865	-	-	8	9	2.0	3223
	2.5	220	0	7	3.5	-10	75	FKM	132T29	4270	481000	-	-	8	8	2.0	3223
	2.5	220	0	-	7	-10	75	FKM	132T29	4270	486265	-	-	-	14	2.0	3223

BRASS

PIPE MOUNTING

**UNIVERSAL**

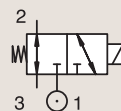

Port size	Orifice Ø	Flow factor	Operating Pressure Differential			Fluid Temp.		Seat Seal	Parker LUCIFER® Valves			ATEX Zone	Protection Mode	Power		Coil Group	Dwg. No.
			Min	Max (MOPD)	Min	Max	Valve Ref.		Housing Ref.	Coil Ref.	AC W			DC W			
BSP	mm	Qn l/min	bar	AC bar	DC bar	°C	°C										
1/4" NPT	6	680	0	10	10	-25	65	NBR	U133X0111	-	492310	1-21	Ex eb mb II T3 to T6	6	6	9.0/10.1/10.2	7422
	6	680	0	-	10	-25	75	NBR	U133X0111	-	492965.01	0-20	Ex ia IIC T6	-	0.3 to 3	9.0/10.1/10.2	7422
	6	680	0	10	10	-25	65	NBR	U133X01111D <sub>1</sub>	-	483270	1-21	Ex db IIC T4 to T6	8	8	11.0	7438

**Notes:**

1. DC voltage only. Minimum drop off voltage is 15% of nominal voltage (former DIN 19251)





### 3 & 5 WAY PNEUMATIC DISTRIBUTORS

# 3/2

## 3 & 5 WAY PNEUMATIC VALVES FOR ACTUATOR CONTROL (PIPE MOUNTING) DIRECT OPERATED

### BRASS PIPE MOUNTING

#### UNIVERSAL

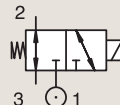

Port size	Orifice Ø 1 mm	Flow factor Qn l/min	Operating Pressure Differential			Fluid Temp.		Seat Seal	Parker LUCIFER® Valves			ATEX Zone	Protection Mode	Power		Coil Group	Dwg. No.	
			Min	Max (MOPD)	AC bar	DC bar	Min		Max	Valve Ref.	Housing Ref.			Coil Ref.	AC W			DC W
			bar	bar			°C		°C									
1/4"	6	680	0	-	10	-25	65	NBR	U133X0131 <sub>1</sub>	-	492310	1-21	Ex eb mb II T3 to T6	-	6	10.1/10.2	8280	
NPT	6	680	0	-	10	-25	65	NBR	U133X0131 <sub>1</sub>	-	496700	1-21	Ex db mb IIC T4 to T6	-	6	10.1/10.2	8280	

#### Notes:

1. DC voltage only (or coil with rectifier). Minimum drop off voltage is 15% of nominal voltage (former DIN 19251)

### BRASS PIPE MOUNTING

#### CONTROL BY ELECTRIC IMPULSE

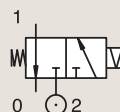

Port size	Orifice Ø 1 mm	Flow factor Qn l/min	Operating Pressure Differential			Fluid Temp.		Seat Seal	Parker LUCIFER® Valves			ATEX Zone	Protection Mode	Power		Coil Group	Dwg. No.	
			Min	Max (MOPD)	AC bar	DC bar	Min		Max	Valve Ref.	Housing Ref.			Coil Ref.	AC W			DC W
			bar	bar			°C		°C									
1/4"	2.5	220	0	-	7	-10	100	FKM	135K03	4269	485400	-	-	-	13	4.0	3510	



### 3 & 5 WAY PNEUMATIC DISTRIBUTORS



For this page	Port size	Orifice (mm)	Qn (l/min)	MOPD (bar)	Fluid Temp (°C)	Amb Temp (°C)
From	1/4"	2.5	220	7	-25	-25
To	1/4"	6	680	10	100	50

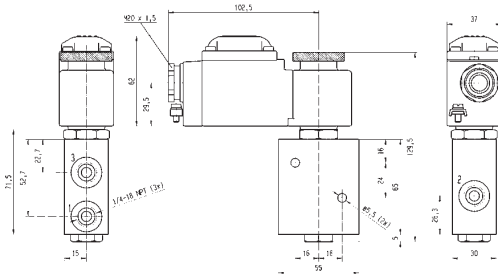

Drawing 8280

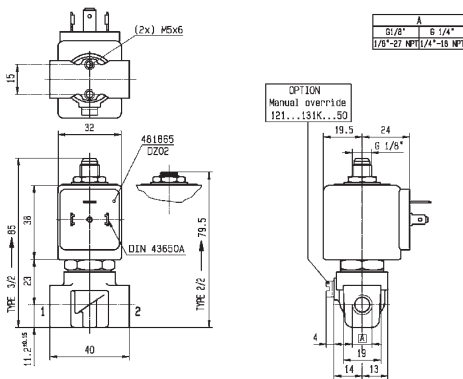

Drawing 3510

**3 & 5 WAY  
PNEUMATIC  
DISTRIBUTORS**

# 3/2

## 3 & 5 WAY PNEUMATIC VALVES FOR ACTUATOR CONTROL (PIPE MOUNTING) DIRECT OPERATED

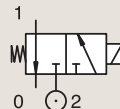
**BRASS**
**SUB-BASE MOUNTING**
**NORMALLY CLOSED**

Port size	Orifice Ø 1 mm	Flow factor Qn l/min	Operating Pressure Differential			Fluid Temp.		Seat Seal	Parker LUCIFER® Valves			ATEX Zone	Protection Mode	Power		Coil Group	Dwg. No.
			Min	Max (MOPD)		Min	Max		Valve Ref.	Housing Ref.	Coil Ref.			AC W	DC W		
			bar	AC bar	DC bar	°C	°C										
SB	2.5	180	0	-	2	-20	75	PUR	131F4397	2995	482740	-	-	-	1.6	6.0/8.0	8022
	2.5	180	0	2	2	-20	75	PUR	131F4397	-	495900	1-21	Ex db mb IIC T4 to T6	2.5	2	6.0/8.0	8022
	2.5	180	0	-	2	-20	75	PUR	131F4397	-	495910	0-20	Ex ia IIC T4 to T6	-	0.3 to 3	6.0/8.0	8022
	2.5	180	0	-	2	-20	75	PUR	131F4397	2995	496125	2-22	Ex nAc nCc IIC T5/T6	-	1.6	6.0/8.0	8022

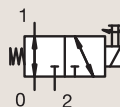
**BRASS**
**SUB-BASE MOUNTING**
**UNIVERSAL**

Port size	Orifice Ø 1 mm	Flow factor Qn l/min	Operating Pressure Differential			Fluid Temp.		Seat Seal	Parker LUCIFER® Valves			ATEX Zone	Protection Mode	Power		Coil Group	Dwg. No.
			Min	Max (MOPD)		Min	Max		Valve Ref.	Housing Ref.	Coil Ref.			AC W	DC W		
			bar	AC bar	DC bar	°C	°C										
SB	2	140	0	7	7	-10	100	FKM	133F4650 <sub>1</sub>	2995	481865	-	-	8	9	2.1	3509
	2	140	0	7	7	-10	120	FKM	133F4650 <sub>1</sub>	4270	481000	-	-	8	8	2.1	3509

**Notes:**

1. With manual override



### 3 & 5 WAY PNEUMATIC DISTRIBUTORS



For this page	Port size	Orifice (mm)	Qn (l/min)	MOPD (bar)	Fluid Temp (°C)	Amb Temp (°C)
From	1/8"	2	140	2	-20	-20
To	5 mm	2.5	180	7	120	50

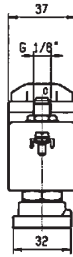
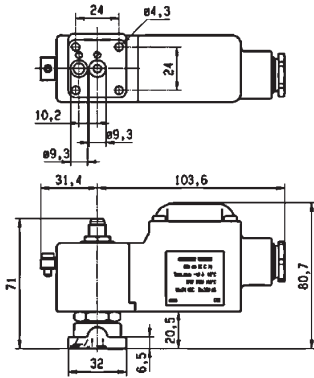

Drawing 8022

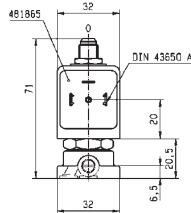
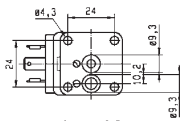

OPTION  
Manual override  
121...131F...50



Drawing 3509

**3 & 5 WAY  
PNEUMATIC  
DISTRIBUTORS**

# 3/2

## 3 & 5 WAY PNEUMATIC VALVES FOR ACTUATOR CONTROL (PIPE MOUNTING) DIRECT OPERATED

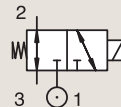
**ANODIZED ALUMINIUM  
PIPE MOUNTING**

**UNIVERSAL**

Port size	Orifice Ø	Flow factor	Operating Pressure Differential			Fluid Temp.		Seat Seal	Parker LUCIFER® Valves			ATEX Zone	Protection Mode	Power		Coil Group	Dwg. No.
			Min	Max (MOPD)	DC bar	Min	Max		Valve Ref.	Housing Ref.	Coil Ref.			AC W	DC W		
1/4"	6	680	0	10	10	-25	75	NBR	133X01	-	492310	1-21	Ex eb mb II T3 to T6	6	6	9.0/10.1/10.2	6960
	6	680	0	-	10	-25	65	NBR	133X01	-	492965.01	0-20	Ex ia IIC T6	-	0.3 to 3	9.0/10.1/10.2	6960
	6	680	0	10	10	-25	65	NBR	133X01	-	496700	1-21	Ex db mb IIC T4 to T6	6	6	9.0/10.1/10.2	6960
	6	680	0	10	10	-25	65	NBR	133X01	-	496895	-	-	8	8	9.0/10.1/10.2	6960
	6	680	0	10	10	-25	80	FKM	133X01001D	-	483270	1-21	Ex db IIC T4 to T6	8	8	11.0	7031
1/4" NPT	6	680	0	10	10	-25	65	NBR	U133X01	-	496700	1-21	Ex db mb IIC T4 to T6	6	6	9.0/10.1/10.2	7422



### 3 & 5 WAY PNEUMATIC DISTRIBUTORS



For this page	Port size	Orifice (mm)	Qn (l/min)	MOPD (bar)	Fluid Temp (°C)	Amb Temp (°C)
From	1/4"	6	680	10	-25	-25
To	1/4"	6	680	10	80	50

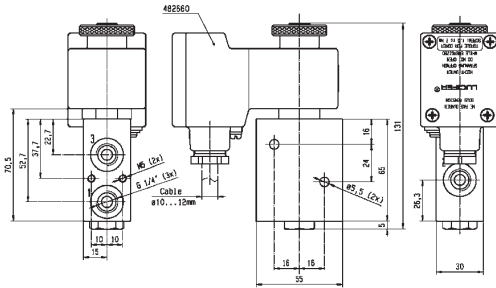

Drawing 6960

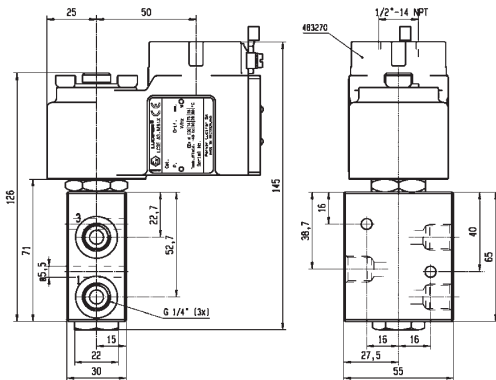

Drawing 7031

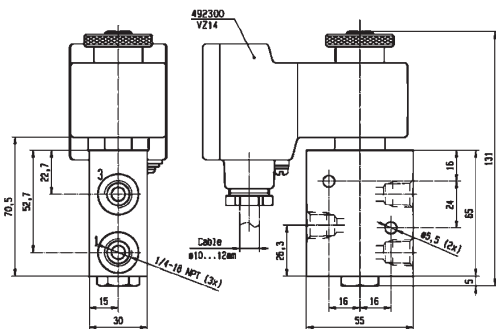

Drawing 7422



### 3 & 5 WAY PNEUMATIC DISTRIBUTORS

# 5/2

## 3 & 5 WAY PNEUMATIC VALVES FOR ACTUATOR CONTROL (PIPE MOUNTING) PILOT OPERATED



Process

### ANODIZED ALUMINIUM PIPE MOUNTING

#### NORMALLY CLOSED

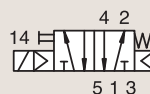

Port size	Orifice Ø	Flow factor	Operating Pressure Differential			Fluid Temp.		Seat Seal	Parker LUCIFER® Valves			ATEX Zone	Protection Mode	Power		Coil Group	Dwg. No.
			Min	Max (MOPD)	DC bar	Min	Max		Valve Ref.	Housing Ref.	Coil Ref.			AC W	DC W		
BSP	1	Qn l/min	bar	AC bar	DC bar	°C	°C										
1/8"	4	600	2	10	10	-25	50	NBR	341P01 <sub>2</sub>	-	482606	1-21	Ex mb IIC T4/T5	2	2.5	1.1	7302
	4	600	2	10	10	-25	80	NBR	341P01 <sub>2</sub>	8993	488980	-	-	2	2.5	1.1	7302
	4	600	2	10	10	-25	80	NBR	341P21 <sub>12</sub>	2995	481865	-	-	8	9	2.1	7296
	4	600	2	10	10	-25	80	NBR	341P21 <sub>12</sub>	4270	481000	-	-	8	8	2.1	7296
	4	600	2	10	10	-40	65	PUR	341P2108 <sub>2</sub>	2995	481865	-	-	8	9	2.1	7296
	4	600	2	10	10	-40	65	PUR	341P2108 <sub>2</sub>	4270	481000	-	-	8	8	2.1	7296
	4	600	2	-	10	-20	65	NBR/PUR	341P2197 <sub>2</sub>	2995	482740	-	-	-	1.6	6.0/8.0	8027
	4	600	2	10	10	-20	65	NBR/PUR	341P2197 <sub>2</sub>	-	495900	1-21	Ex db mb IIC T4 to T6	2.5	2	6.0/8.0	8027
	4	600	2	-	10	-20	65	NBR/PUR	341P2197 <sub>2</sub>	-	495910	0-20	Ex ia IIC T4 to T6	-	0.3 to 3	6.0/8.0	8027
	4	600	2	-	10	-20	65	NBR/PUR	341P2197 <sub>2</sub>	2995	496125	2-22	Ex nAc nCc IIC T5/T6	-	1.6	6.0/8.0	8027

#### Notes:

1. Pilot seat in FKM
2. With manual override



### 3 & 5 WAY PNEUMATIC DISTRIBUTORS



For this page	Port size	Orifice (mm)	Qn (l/min)	MOPD (bar)	Fluid Temp (°C)	Amb Temp (°C)
From	1/8"	4	600	10	-40	-40
To	1/8"	4	600	10	80	50

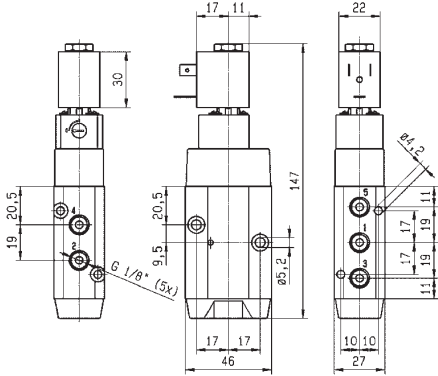

Drawing 7302

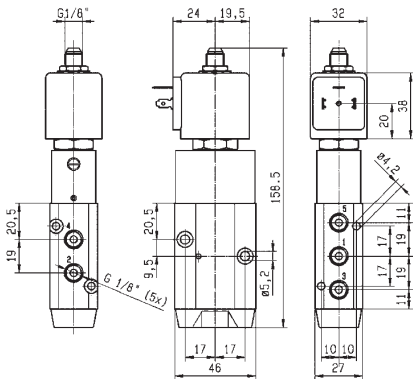

Drawing 7296

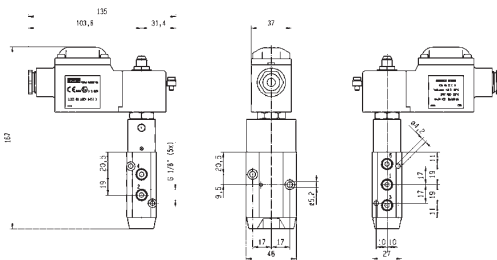

Drawing 8027



### 3 & 5 WAY PNEUMATIC DISTRIBUTORS

# 5/2

## 3 & 5 WAY PNEUMATIC VALVES FOR ACTUATOR CONTROL (PIPE MOUNTING) PILOT OPERATED

### ANODIZED ALUMINIUM PIPE MOUNTING

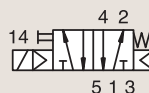

### NORMALLY CLOSED

Port size	Orifice Ø	Flow factor	Operating Pressure Differential			Fluid Temp.		Seat Seal	Parker LUCIFER® Valves			ATEX Zone	Protection Mode	Power		Coil Group	Dwg. No.
			Min	Max (MOPD)	DC bar	Min	Max		Valve Ref.	Housing Ref.	Coil Ref.			AC W	DC W		
1/8"	15	600	2	-	10	-10	55	NBR	341P2190 <sub>2</sub>	2995	483580.01	0-20	Ex ia IIC T6	-	0.5 to 3	7.0/8.0	7351
	15	600	2	-	10	-10	75	NBR	341P2190 <sub>2</sub>	-	488660.01	0-20	Ex ia IIC T6	-	0.3 to 3	7.0/8.0	7351
	15	600	2	-	10	-10	75	NBR	341P2190 <sub>2</sub>	-	495910	0-20	Ex ia IIC T4 to T6	-	0.3 to 3	7.0/8.0	7351
1/4"	7	1250	2.5	10	10	-10	50	NBR	341P03 <sub>2</sub>	-	496131	-	-	3	3	1.2	8218
	7	1250	2.5	10	10	-10	50	NBR	341P03 <sub>2</sub>	-	496482	-	-	3	3	1.2	8218
	7	1250	2.5	10	10	-10	50	NBR	341P03 <sub>2</sub>	-	496637	22	Ex tc IIIC T95°C	3	3	1.2	8218
	7	1250	2.5	10	10	-10	50	NBR	341P33 <sub>2</sub>	2995	481865	-	-	8	9	2.1	8219
	7	1250	2.5	10	10	-10	50	NBR	341P33 <sub>2</sub>	2995	495870	2-22	Ex nAc nCc IIC T3/T4	8	9	2.1	8219
	7	1250	2.5	10	10	-10	50	NBR	341P33 <sub>2</sub>	-	495905	1-21	Ex db mb IIC T4	8	8	2.1	8219
	8	1400	2	10	10	-25	80	NBR	341P02 <sub>2</sub>	-	482606	1-21	Ex mb IIC T4/T5	2	2.5	1.1	7314
8	1400	2	10	10	-25	80	NBR	341P02 <sub>2</sub>	8993	488980	-	-	2	2.5	1.1	7314	

#### Notes:

1. Pilot seat in FKM
2. With manual override

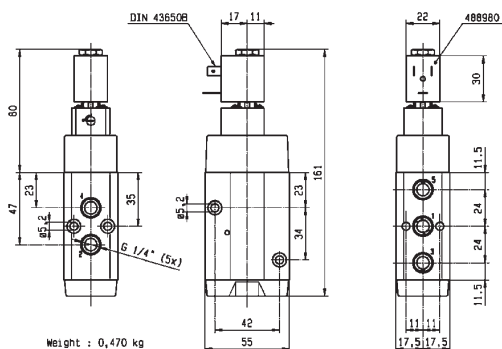

Drawing 7314



**3 & 5 WAY  
PNEUMATIC  
DISTRIBUTORS**



For this page	Port size	Orifice (mm)	Qn (l/min)	MOPD (bar)	Fluid Temp (°C)	Amb Temp (°C)
From	1/8"	7	600	10	-25	-25
To	1/4"	15	1400	10	80	50

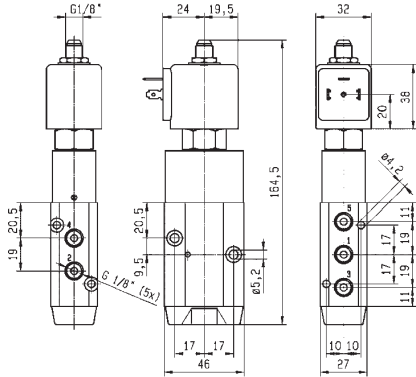

Drawing 7351

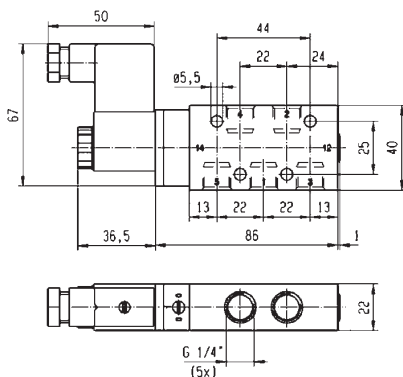

Drawing 8218

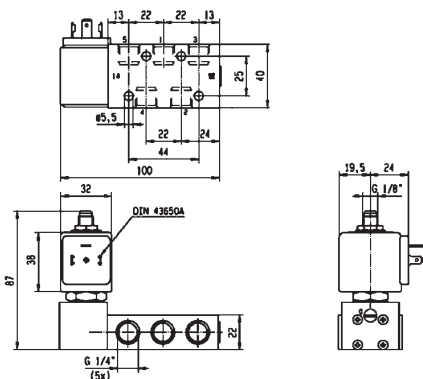

Drawing 8219



**3 & 5 WAY  
PNEUMATIC  
DISTRIBUTORS**

# 5/2

## 3 & 5 WAY PNEUMATIC VALVES FOR ACTUATOR CONTROL (PIPE MOUNTING) PILOT OPERATED

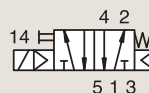
**ANODIZED ALUMINIUM  
PIPE MOUNTING**

**NORMALLY CLOSED**

Port size	Orifice Ø	Flow factor	Operating Pressure Differential			Fluid Temp.		Seat Seal	Parker LUCIFER® Valves			ATEX Zone	Protection Mode	Power		Coil Group	Dwg. No.
			Min	Max (MOPD)	DC bar	Min	Max		Valve Ref.	Housing Ref.	Coil Ref.			AC W	DC W		
BSP	1	Qn l/min	bar	AC bar	DC bar	°C	°C										
1/4"	8	1400	2	10	10	-25	80	NBR	341P22 <sub>12</sub>	2995	481865	-	-	8	9	2.1	7319
	8	1400	2	10	10	-25	80	NBR	341P22 <sub>12</sub>	4270	481000	-	-	8	8	2.1	7319
	8	1400	2	-	10	-25	55	NBR	341P2290	2995	483580.01	0-20	Ex ia IIC T6	-	0.5 to 3	7.0/8.0	7352
	8	1400	2	-	10	-25	75	NBR	341P2290	-	488660.01	0-20	Ex ia IIC T6	-	0.3 to 3	7.0/8.0	7352
	8	1400	2	-	10	-25	75	NBR	341P2290	-	495910	0-20	Ex ia IIC T4 to T6	-	0.3 to 3	7.0/8.0	7352
	8	1400	2	-	10	-20	80	NBR	341P2297 <sub>23</sub>	2995	482740	-	-	-	1.6	6.0/8.0	8030
	8	1400	2	10	10	-20	80	NBR	341P2297 <sub>23</sub>	-	495900	1-21	Ex db mb IIC T4 to T6	2.5	2	6.0/8.0	8030
	8	1400	2	-	10	-20	80	NBR	341P2297 <sub>23</sub>	-	495910	0-20	Ex ia IIC T4 to T6	-	0.3 to 3	6.0/8.0	8030
	8	1400	2	-	10	-20	80	NBR	341P2297 <sub>23</sub>	2995	496125	2-22	Ex nAc nCc IIC T5/T6	-	1.6	6.0/8.0	8030

**Notes:**

1. Pilot seat in FKM
2. With manual override
3. Pilot seat in PUR



### 3 & 5 WAY PNEUMATIC DISTRIBUTORS



For this page	Port size	Orifice (mm)	Qn (l/min)	MOPD (bar)	Fluid Temp (°C)	Amb Temp (°C)
From	1/4"	8	1400	10	-25	-25
To	1/4"	8	1400	10	80	50

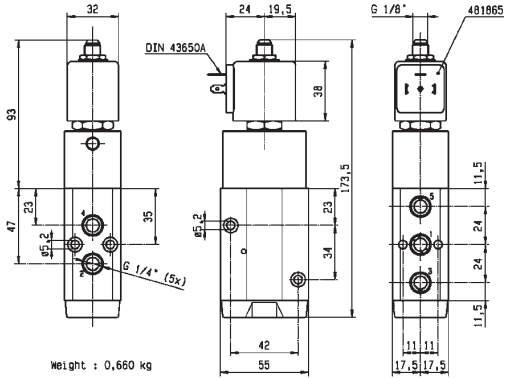

Weight : 0,660 kg



Drawing 7319

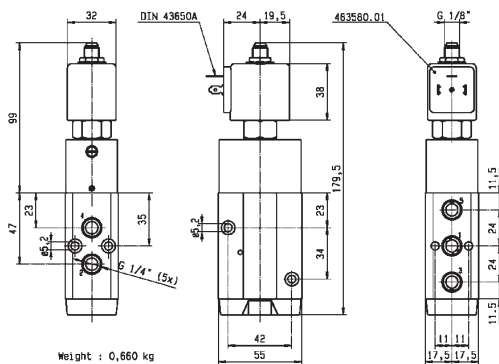

Weight : 0,660 kg



Drawing 7352

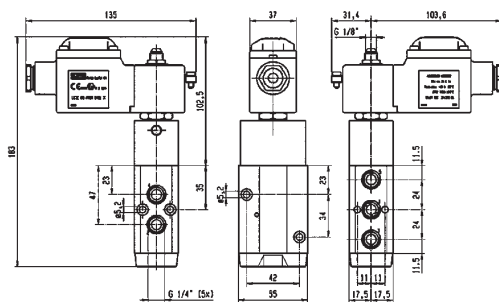

Drawing 8030



### 3 & 5 WAY PNEUMATIC DISTRIBUTORS

# 5/2

## 3 & 5 WAY PNEUMATIC VALVES FOR ACTUATOR CONTROL (PIPE MOUNTING) PILOT OPERATED

ANODIZED ALUMINIUM  
PIPE MOUNTING

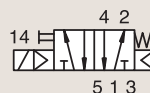

**NORMALLY CLOSED**

Port size	Orifice Ø	Flow factor	Operating Pressure Differential			Fluid Temp.		Seat Seal	Parker LUCIFER® Valves			ATEX Zone	Protection Mode	Power		Coil Group	Dwg. No.
			Min	Max (MOPD)	DC	Min	Max		Valve Ref.	Housing Ref.	Coil Ref.			AC W	DC W		
BSP	1	Qn l/min	bar	AC bar	DC bar	°C	°C										
1/2"	12	3000	2.5	10	10	-10	50	NBR	341P04 <sub>1</sub>	-	496131	-	-	3	3	1.2	8220
	12	3000	2.5	10	10	-10	50	NBR	341P04 <sub>1</sub>	-	496482	-	-	3	3	1.2	8220
	12	3000	2.5	10	10	-10	50	NBR	341P04 <sub>1</sub>	-	496637	22	Ex tc IIC T95°C	3	3	1.2	8220
	12	3000	2.5	10	10	-10	50	NBR	341P34 <sub>1</sub>	2995	481865	-	-	8	9	2.1	8221
	12	3000	2.5	10	10	-10	50	NBR	341P34 <sub>1</sub>	2995	495870	2-22	Ex nAc nCc IIC T3/T4	8	9	2.1	8221
	12	3000	2.5	10	10	-10	50	NBR	341P34 <sub>1</sub>	-	495905	1-21	Ex db mb IIC T4	8	8	2.1	8221

**Notes:**

1. With manual override



### 3 & 5 WAY PNEUMATIC DISTRIBUTORS



For this page	Port size	Orifice (mm)	Qn (l/min)	MOPD (bar)	Fluid Temp (°C)	Amb Temp (°C)
From	1/2"	12	3000	10	-10	-10
To	1/2"	12	3000	10	50	50

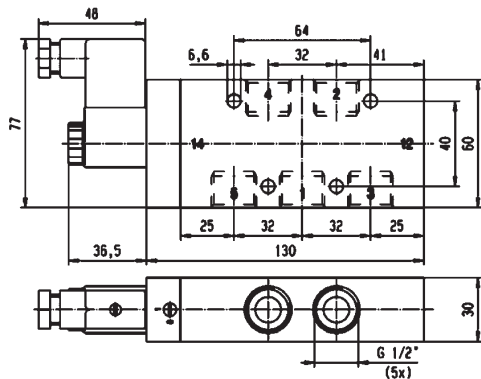

Drawing 8220

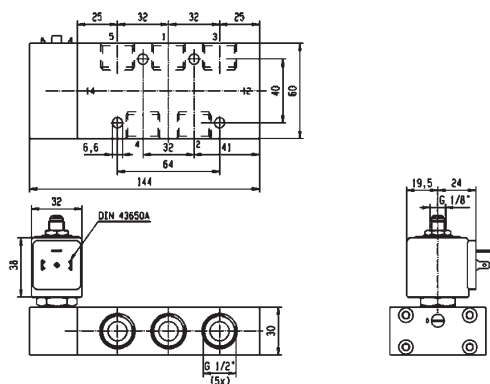

Drawing 8221

### 3 & 5 WAY PNEUMATIC DISTRIBUTORS

# 5/2

## 3 & 5 WAY PNEUMATIC VALVES FOR ACTUATOR CONTROL (PIPE MOUNTING) PILOT OPERATED

### ANODIZED ALUMINIUM PIPE MOUNTING

#### DUAL SOLENOIDS

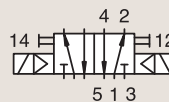

Port size BSP	Orifice Ø mm	Flow factor Qn l/min	Operating Pressure Differential			Fluid Temp.		Seat Seal	Parker LUCIFER® Valves			ATEX Zone	Protection Mode	Power		Coil Group	Dwg. No.
			Min bar	Max (MOPD) AC bar	DC bar	Min °C	Max °C		Valve Ref.	Housing Ref.	Coil Ref.			AC W	DC W		
1/8"	4	400	2	10	10	-25	80	NBR	347P01 <sub>2</sub>	-	482606	1-21	Ex mb IIC T4/T5	2	2.5	1.1	7306
	4	400	2	10	10	-25	80	NBR	347P01 <sub>2</sub>	8993	488980	-	-	2	2.5	1.1	7306
	4	400	2	10	10	-25	80	NBR	347P21 <sub>12</sub>	2995	481865	-	-	8	9	2.1	7298
	4	400	2	10	10	-25	80	NBR	347P21 <sub>12</sub>	4270	481000	-	-	8	8	2.1	7298
	4	400	2	-	10	-25	55	NBR	347P2190	2995	483580.01	0-20	Ex ia IIC T6	-	0.5 to 3	7.0/8.0	7353
	4	400	2	-	10	-25	75	NBR	347P2190	-	488660.01	0-20	Ex ia IIC T6	-	0.3 to 3	7.0/8.0	7353
	4	400	2	-	10	-25	75	NBR	347P2190	-	495910	0-20	Ex ia IIC T4 to T6	-	0.3 to 3	7.0/8.0	7353
	4	400	2	-	10	-20	65	NBR/PUR	347P2197 <sub>2</sub>	2995	482740	-	-	-	1.6	6.0/8.0	8028
	4	400	2	10	10	-20	65	NBR/PUR	347P2197 <sub>2</sub>	-	495900	1-21	Ex db mb IIC T4 to T6	2.5	2	6.0/8.0	8028
	4	400	2	-	10	-20	65	NBR/PUR	347P2197 <sub>2</sub>	-	495910	0-20	Ex ia IIC T4 to T6	-	0.3 to 3	6.0/8.0	8028
4	400	2	-	10	-20	65	NBR/PUR	347P2197 <sub>2</sub>	2995	496125	2-22	Ex nAc nCc IIC T5/T6	-	1.6	6.0/8.0	8028	

#### Notes:

- Pilot seat in FKM
- With manual override

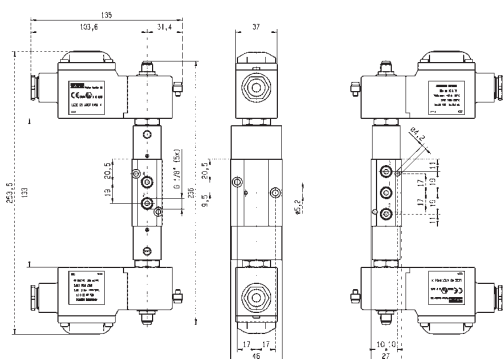

Drawing 8028



### 3 & 5 WAY PNEUMATIC DISTRIBUTORS



For this page	Port size	Orifice (mm)	Qn (l/min)	MOPD (bar)	Fluid Temp (°C)	Amb Temp (°C)
From	1/8"	4	400	10	-25	-25
To	1/8"	4	400	10	80	50

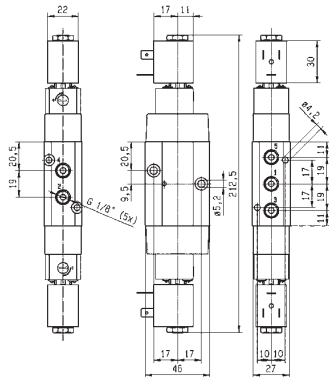

Drawing 7306

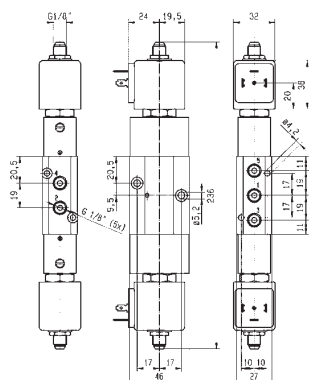

Drawing 7298

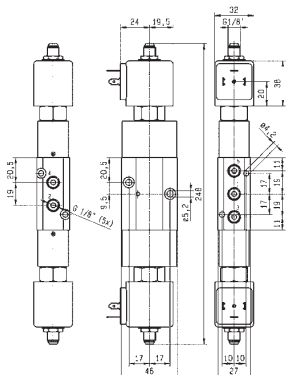

Drawing 7353



### 3 & 5 WAY PNEUMATIC DISTRIBUTORS

# 5/2

## 3 & 5 WAY PNEUMATIC VALVES FOR ACTUATOR CONTROL (PIPE MOUNTING) PILOT OPERATED

### ANODIZED ALUMINIUM PIPE MOUNTING

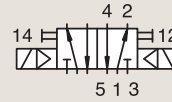

### DUAL SOLENOIDS

Port size BSP	Orifice Ø 1	Flow factor Qn l/min	Operating Pressure Differential			Fluid Temp.		Seat Seal	Parker LUCIFER® Valves			ATEX Zone	Protection Mode	Power		Coil Group	Dwg. No.
			Min	Max (MOPD)	DC bar	Min	Max		Valve Ref.	Housing Ref.	Coil Ref.			AC W	DC W		
1/4"	7	1250	2.5	10	10	-10	50	NBR	347P03 <sub>2</sub>	-	496131	-	-	3	3	1.2	8222
	7	1250	2.5	10	10	-10	50	NBR	347P03 <sub>2</sub>	-	496482	-	-	3	3	1.2	8222
	7	1250	2.5	10	10	-10	50	NBR	347P03 <sub>2</sub>	-	496637	22	Ex tc IIC T95°C	3	3	1.2	8222
	7	1250	2.5	10	10	-10	50	NBR	347P33 <sub>12</sub>	2995	481865	-	-	8	9	2.1	8223
	7	1250	2.5	10	10	-10	50	NBR	347P33 <sub>12</sub>	2995	495870	2-22	Ex nAc nCc IIC T3/T4	8	9	2.1	8223
	7	1250	2.5	10	10	-10	50	NBR	347P33 <sub>12</sub>	-	495905	1-21	Ex db mb IIC T4	8	8	2.1	8223
	8	1400	2	10	10	-25	80	NBR	347P02 <sub>2</sub>	-	482606	1-21	Ex mb IIC T4/T5	2	2.5	1.1	7316
	8	1400	2	10	10	-25	80	NBR	347P02 <sub>2</sub>	8993	488980	-	-	2	2.5	1.1	7316
	8	1400	2	10	10	-25	80	NBR	347P22 <sub>12</sub>	2995	481865	-	-	8	9	2.1	7321
8	1400	2	10	10	-25	80	NBR	347P22 <sub>12</sub>	4270	481000	-	-	8	8	2.1	7321	

#### Notes:

1. Pilot seat in FKM
2. With manual override

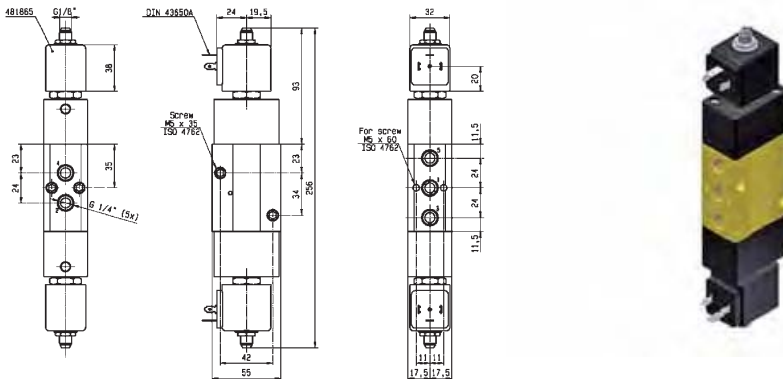

Drawing 7321



### 3 & 5 WAY PNEUMATIC DISTRIBUTORS



For this page	Port size	Orifice (mm)	Qn (l/min)	MOPD (bar)	Fluid Temp (°C)	Amb Temp (°C)
From	1/4"	7	1250	10	-25	-25
To	1/4"	8	1400	10	80	50

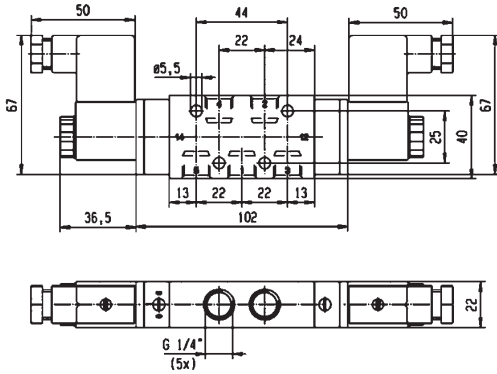

Drawing 8222

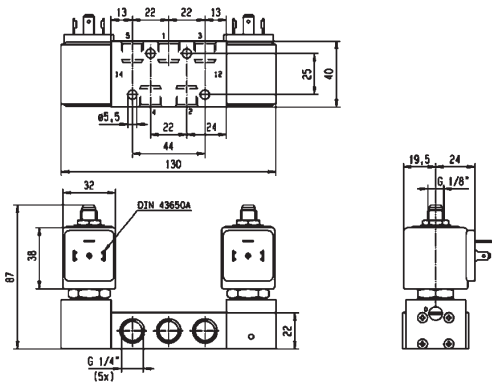

Drawing 8223

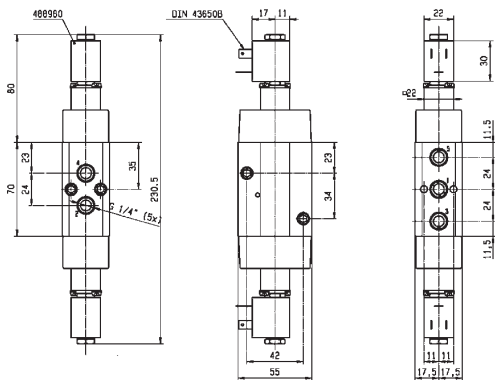

Drawing 7316



### 3 & 5 WAY PNEUMATIC DISTRIBUTORS

# 5/2

## 3 & 5 WAY PNEUMATIC VALVES FOR ACTUATOR CONTROL (PIPE MOUNTING) PILOT OPERATED

### ANODIZED ALUMINIUM PIPE MOUNTING

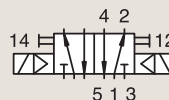

#### DUAL SOLENOIDS

Port size	Orifice Ø	Flow factor	Operating Pressure Differential			Fluid Temp.		Seat Seal	Parker LUCIFER® Valves			ATEX Zone	Protection Mode	Power		Coil Group	Dwg. No.
			Min	Max (MOPD)	DC bar	Min	Max		Valve Ref.	Housing Ref.	Coil Ref.			AC W	DC W		
			bar	AC bar	DC bar	°C	°C										
1/2"	12	3000	2.5	10	10	-10	50	NBR	347P04 <sub>2</sub>	-	496131	-	-	3	3	1.2	8224
	12	3000	2.5	10	10	-10	50	NBR	347P04 <sub>2</sub>	-	496482	-	-	3	3	1.2	8224
	12	3000	2.5	10	10	-10	50	NBR	347P04 <sub>2</sub>	-	496637	22	Ex tc IIC T95°C	3	3	1.2	8224
	12	3000	2.5	10	10	-10	50	NBR	347P34 <sub>12</sub>	2995	481865	-	-	8	9	2.1	8225
	12	3000	2.5	10	10	-10	50	NBR	347P34 <sub>12</sub>	2995	495870	2-22	Ex nAc nCc IIC T3/T4	8	9	2.1	8225
	12	3000	2.5	10	10	-10	50	NBR	347P34 <sub>12</sub>	-	495905	1-21	Ex db mb IIC T4	8	8	2.1	8225

#### Notes:

1. Pilot seat in FKM
2. With manual override

### ANODIZED ALUMINIUM PIPE MOUNTING

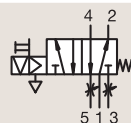

#### CONTROL BY ELECTRIC IMPULSE

Port size	Orifice Ø	Flow factor	Operating Pressure Differential			Fluid Temp.		Seat Seal	Parker LUCIFER® Valves			ATEX Zone	Protection Mode	Power		Coil Group	Dwg. No.
			Min	Max (MOPD)	DC bar	Min	Max		Valve Ref.	Housing Ref.	Coil Ref.			AC W	DC W		
			bar	AC bar	DC bar	°C	°C										
1/8"	4	600	2	-	10	-25	80	NBR	345P21	4269	485400	-	-	-	13	4.0	8123



### 3 & 5 WAY PNEUMATIC DISTRIBUTORS



For this page	Port size	Orifice (mm)	Qn (l/min)	MOPD (bar)	Fluid Temp (°C)	Amb Temp (°C)
From	1/8"	4	600	10	-25	-25
To	1/2"	12	3000	10	80	50

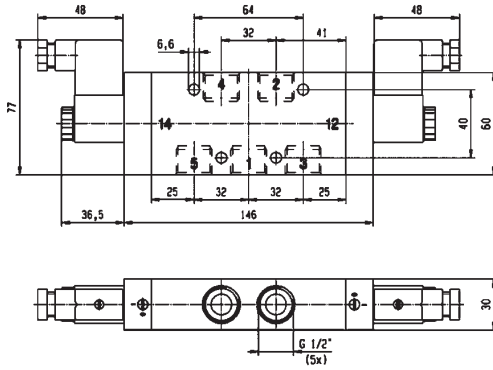

Drawing 8224

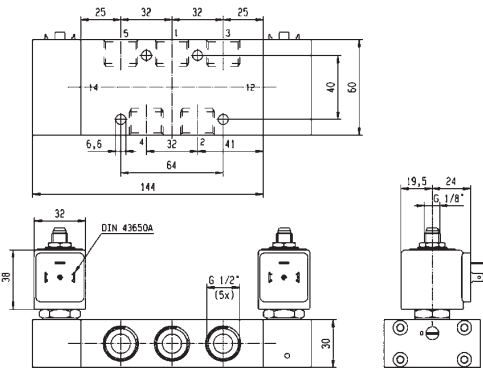

Drawing 8225

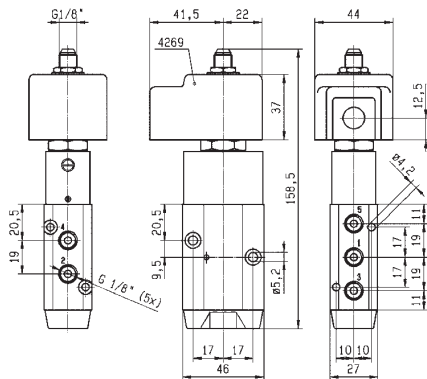

Drawing 8123



**3 & 5 WAY  
PNEUMATIC  
DISTRIBUTORS**

# 3/2

## 3 & 5 WAY PNEUMATIC VALVES FOR ACTUATOR CONTROL (PIPE MOUNTING) MANUAL RESET



Process

**BRASS  
PIPE MOUNTING**

**UNIVERSAL**

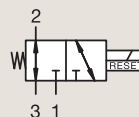

Port size	Orifice Ø 1	Flow factor Qn l/min mm	Operating Pressure Differential			Fluid Temp.		Seat Seal	Parker LUCIFER® Valves			ATEX Zone	Protection Mode	Power		Coil Group	Dwg. No.
			Min bar	Max (MOPD) AC bar DC bar	Min °C	Max °C	Valve Ref.		Housing Ref.	Coil Ref.	AC W			DC W			
1/4" NPT	6	680	0	10	10	-25	65	NBR	U033X0111	-	492310	1-21	Ex eb mb II T3 to T6	6	6	10.1/10.2/12.0	7641
	6	680	0	10	10	-25	65	NBR	U033X0111	-	496700	1-21	Ex db mb IIC T4 to T6	6	6	10.1/10.2/12.0	7641



### 3 & 5 WAY PNEUMATIC DISTRIBUTORS



For this page	Port size	Orifice (mm)	Qn (l/min)	MOPD (bar)	Fluid Temp (°C)	Amb Temp (°C)
From	1/4"	6	680	10	-25	-25
To	1/4"	6	680	10	65	65

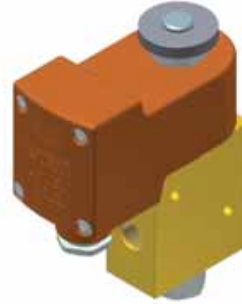
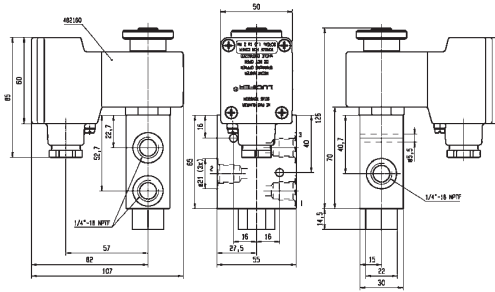

Drawing 7641

## 3 & 5 WAY PNEUMATIC DISTRIBUTORS FOR ACTUATION CONTROL

## 3 & 5 WAY PNEUMATIC DISTRIBUTORS FOR ACTUATION CONTROL



### 3 & 5 WAY PNEUMATIC VALVES FOR ACTUATOR CONTROL (NAMUR)



**3/2**  
**5/2**  
**5/3**

Actuation	Body	Function	Port Size	Orifice (mm)	Qn (l/min)	MOPD (bar)	Max Fluid Temp. (°C)	Page Parker Valves	Page Parker LUCIFER® Valves	
Direct Operated	Anodized aluminium/ NAMUR	Normally Closed	1/4"	6	680	10	75	-	334	
Pilot Operated	Anodized aluminium/ NAMUR/Spool	Solenoid operated - spring return	1/8"-1/4"	4 to 8	1400	10	80	-	340	
			1/4"	7 to 8	1400	10	80	-	336	
			1/2"	12	3000	10	50	-	336	
		Dual Solenoids	1/8"-1/4"	4	400	10	80	-	352	
			1/4"	7 to 8	1400	10	120	-	354	
			1/2"	12	3000	10	120	-	356	
		W1 closed center position	1/8"-1/4"	4	400	10	80	-	358	
			1/4"	4 to 7	1250	10	120	-	358	
		W3 exhausted in center position	Control by Electric Impulse	1/8"-1/4"	4	600	10	80	-	362
				1/8"-1/4"	4	355	10	75	-	362
Air Operated	Anodized aluminium/ NAMUR/Poppet	Solenoid operated - spring return	1/8"-1/4"	4	355	10	75	-	362	
	Anodized aluminium/ NAMUR	W1 closed center position	1/4"	7	1250	10	50	-	372	
			Air operated - spring return	1/8"-1/4"	4	600	10	80	-	368
		Air operated and return	1/4"	7	1250	10	50	-	366	
			1/2"	12	3000	10	50	-	366	
			1/4"	7	1250	10	50	-	370	

### 3 & 5 WAY PNEUMATIC DISTRIBUTORS

# 3/2

## 3 & 5 WAY PNEUMATIC VALVES FOR ACTUATOR CONTROL (NAMUR) DIRECT OPERATED



Process

### ANODIZED ALUMINIUM NAMUR

#### NORMALLY CLOSED

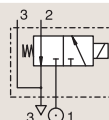

Port size	Orifice Ø	Flow factor	Operating Pressure Differential			Fluid Temp.		Seat Seal	Parker LUCIFER® Valves			ATEX Zone	Protection Mode	Power		Coil Group	Dwg. No.
			Min	Max (MOPD)	DC bar	Min	Max		Valve Ref.	Housing Ref.	Coil Ref.			AC W	DC W		
BSP	1	Qn l/min	bar	AC bar	DC bar	°C	°C										
1/4"	6	680	0	10	10	-25	75	NBR	131X1101	-	492310	1-21	Ex eb mb II T3 to T6	6	6	9.0/10.1	7336
	6	680	0	-	10	-25	75	NBR	131X1101	-	492965.01	0-20	Ex ia IIC T6	-	0.3 to 3	9.0/10.1	7336
	6	680	0	10	10	-25	75	NBR	131X1101	-	496700	1-21	Ex db mb IIC T4 to T6	6	6	9.0/10.1	7336
	6	680	0	10	10	-25	75	NBR	131X1101	-	496895	-	-	8	8	9.0/10.1	7336
	6	680	0	-	10	-25	65	NBR	131X1131 <sub>1</sub>	-	492310	1-21	Ex eb mb II T3 to T6	-	6	10.1/10.2	7336
	6	680	0	-	10	-25	65	NBR	131X1131 <sub>1</sub>	-	496700	1-21	Ex db mb IIC T4 to T6	-	6	10.1/10.2	7336
1/4" NPT	6	680	0	-	10	-25	75	NBR	131X1131 <sub>1</sub>	-	496895	-	-	-	8	10.1/10.2	7336
	6	680	0	-	10	-25	75	NBR	U131X1101	-	492965.01	0-20	Ex ia IIC T6	-	0.3 to 3	10.1/10.2	7336
	6	680	0	10	10	-25	65	NBR	U131X1101	-	496700	1-21	Ex db mb IIC T4 to T6	6	6	10.1/10.2	7336
6	680	0	10	10	-25	65	NBR	U131X1101	-	496895	-	-	8	8	10.1/10.2	7336	

**Notes:**

1. DC voltage only. Minimum drop off voltage is 15% of nominal voltage (former DIN 19251)



### 3 & 5 WAY PNEUMATIC DISTRIBUTORS



For this page	Port size	Orifice (mm)	Qn (l/min)	MOPD (bar)	Fluid Temp (°C)	Amb Temp (°C)
From	1/4"	6	680	10	-25	-25
To	1/4"	6	680	10	75	65

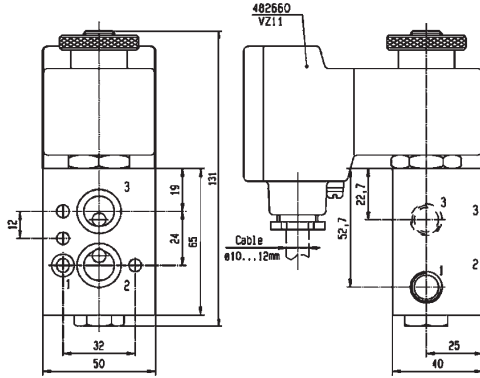

Drawing 7336

### 3 & 5 WAY PNEUMATIC DISTRIBUTORS

# 3/2

## 3 & 5 WAY PNEUMATIC VALVES FOR ACTUATOR CONTROL (NAMUR) PILOT OPERATED



Process

### ANODIZED ALUMINIUM NAMUR

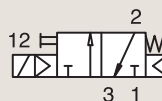

### SOLENOID OPERATED - SPRING RETURN

Port size	Orifice Ø	Flow factor	Operating Pressure Differential			Fluid Temp.		Seat Seal	Parker LUCIFER® Valves			ATEX Zone	Protection Mode	Power		Coil Group	Dwg. No.
			Min	Max (MOPD)	DC bar	Min	Max		Valve Ref.	Housing Ref.	Coil Ref.			AC W	DC W		
BSP	1	Qn l/min	bar	AC bar	DC bar	°C	°C										
1/4"	7	1250	2.5	10	10	-10	50	NBR	331N03 <sub>1</sub>	-	496131	-	-	3	3	1.2	8056
	7	1250	2.5	10	10	-10	50	NBR	331N03 <sub>1</sub>	-	496482	-	-	3	3	1.2	8056
	7	1250	2.5	10	10	-10	50	NBR	331N03 <sub>1</sub>	-	496637	22	Ex tc IIIC T95°C	3	3	1.2	8056
1/2"	12	3000	2.5	10	10	-10	50	NBR	331N04 <sub>1</sub>	-	496131	-	-	3	3	1.2	8060
	12	3000	2.5	10	10	-10	50	NBR	331N04 <sub>1</sub>	-	496482	-	-	3	3	1.2	8060
	12	3000	2.5	10	10	-10	50	NBR	331N04 <sub>1</sub>	-	496637	22	Ex tc IIIC T95°C	3	3	1.2	8060
	12	3000	2.5	10	10	-10	50	NBR	331N0402	-	496131	-	-	3	3	1.2	8251
	12	3000	2.5	10	10	-10	50	NBR	331N0402	-	496482	-	-	3	3	1.2	8251

**Notes:**

1. With manual override



### 3 & 5 WAY PNEUMATIC DISTRIBUTORS



For this page	Port size	Orifice (mm)	Qn (l/min)	MOPD (bar)	Fluid Temp (°C)	Amb Temp (°C)
From	1/4"	7	1250	10	-10	-10
To	1/2"	12	3000	10	50	50

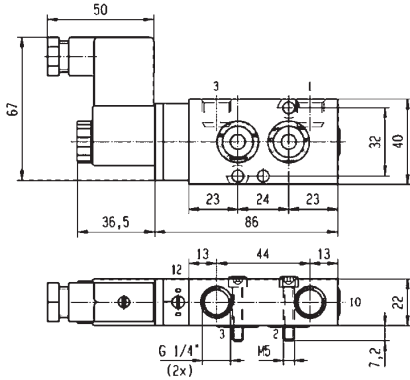

Drawing 8056

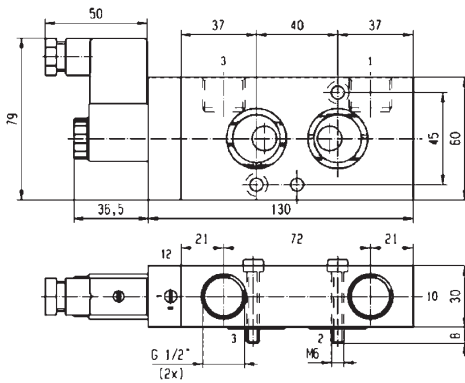

Drawing 8060

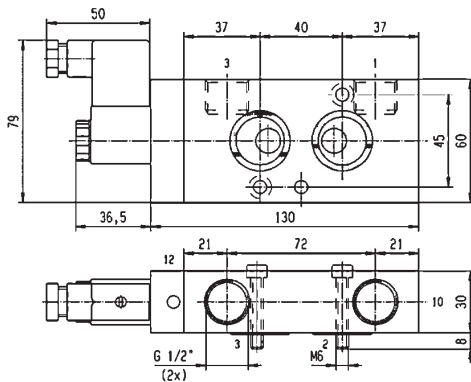

Drawing 8251



### 3 & 5 WAY PNEUMATIC DISTRIBUTORS

# 3/2

## 3 & 5 WAY PNEUMATIC VALVES FOR ACTUATOR CONTROL (NAMUR) PILOT OPERATED

ANODIZED ALUMINIUM  
NAMUR

**SOLENOID OPERATED - SPRING RETURN**

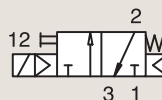

Port size	Orifice Ø	Flow factor	Operating Pressure Differential			Fluid Temp.		Seat Seal	Parker LUCIFER® Valves			ATEX Zone	Protection Mode	Power		Coil Group	Dwg. No.
			Min	Max (MOPD)	DC bar	Min	Max		Valve Ref.	Housing Ref.	Coil Ref.			AC W	DC W		
1/2"	12	3000	2.5	10	10	-10	50	NBR	331N34 <sub>12</sub>	2995	481865	-	-	8	9	2.1	8210
	12	3000	2.5	10	10	-10	50	NBR	331N34 <sub>12</sub>	2995	495870	2-22	Ex nAc nCc IIC T3/T4	8	9	2.1	8210
	12	3000	2.5	10	10	-10	50	NBR	331N34 <sub>12</sub>	-	495905	1-21	Ex db mb IIC T4	8	8	2.1	8210
	12	3000	2.5	10	10	-10	50	NBR	331N3402 <sub>2</sub>	2995	481865	-	-	8	9	2.1	8252

**Notes:**

1. With manual override
2. Pilot seat in FKM



### 3 & 5 WAY PNEUMATIC DISTRIBUTORS



For this page	Port size	Orifice (mm)	Qn (l/min)	MOPD (bar)	Fluid Temp (°C)	Amb Temp (°C)
From	1/2"	12	3000	10	-10	-10
To	1/2"	12	3000	10	50	50

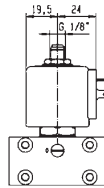
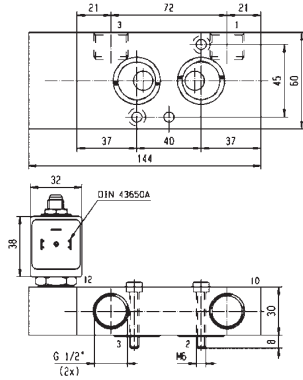

Drawing 8210

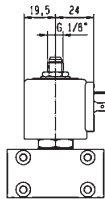
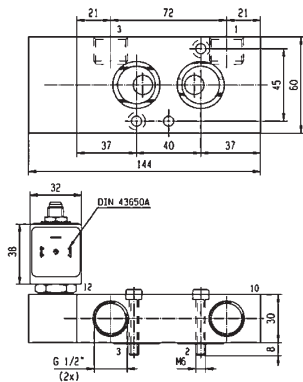

Drawing 8252

### 3 & 5 WAY PNEUMATIC DISTRIBUTORS

# 3/2-5/2

## 3 & 5 WAY PNEUMATIC VALVES FOR ACTUATOR CONTROL (NAMUR) PILOT OPERATED

ANODIZED ALUMINIUM  
NAMUR

SOLENOID OPERATED - SPRING RETURN

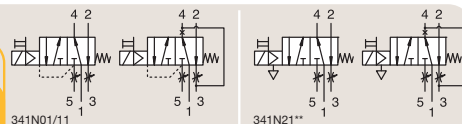

Port size	Orifice Ø	Flow factor	Operating Pressure Differential			Fluid Temp.		Seat Seal	Parker LUCIFER® Valves			ATEX Zone	Protection Mode	Power		Coil Group	Dwg. No.
			Min	Max (MOPD)	DC bar	Min	Max		Valve Ref.	Housing Ref.	Coil Ref.			AC W	DC W		
1/8"- 1/4"	4	600	2	10	10	-25	80	NBR	341N01 <sub>12</sub>	8993	488980	-	-	2	2.5	1.1	7301
	4	600	2	10	10	-25	80	NBR	341N11 <sub>12</sub>	8993	488980	-	-	2	2.5	1.1	7300
	4	600	2	10	10	-25	80	NBR	341N21 <sub>12</sub>	2995	481865	-	-	8	9	2.1	7311
	4	600	2	10	10	-25	80	NBR	341N21 <sub>12</sub>	4270	481000	-	-	8	8	2.1	7311
	4	600	2	-	10	-25	55	NBR	341N2190 <sub>12</sub>	2995	483580.01	0-20	Ex ia IIC T6	-	0.5 to 3	7.0/8.0	7874
	4	600	2	-	10	-25	55	NBR	341N2190 <sub>12</sub>	-	495910	0-20	Ex ia IIC T4 to T6	-	0.3 to 3	7.0/8.0	7874

**Notes:**

- 1. With captured exhaust
- 2. With manual override

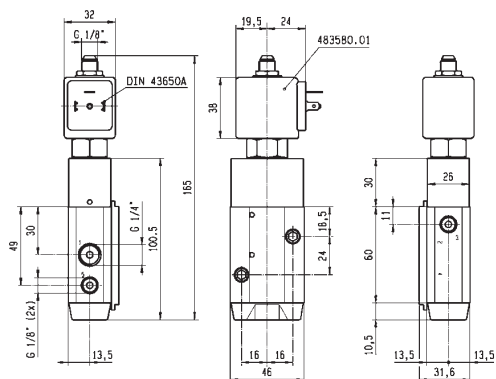

Drawing 7874



### 3 & 5 WAY PNEUMATIC DISTRIBUTORS



For this page	Port size	Orifice (mm)	Qn (l/min)	MOPD (bar)	Fluid Temp (°C)	Amb Temp (°C)
From	1/8"-1/4"	4	600	10	-25	-25
To	1/8"-1/4"	4	600	10	80	50

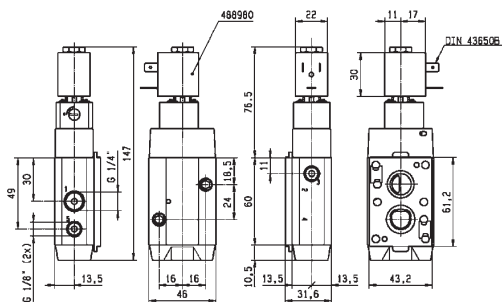

Drawing 7301

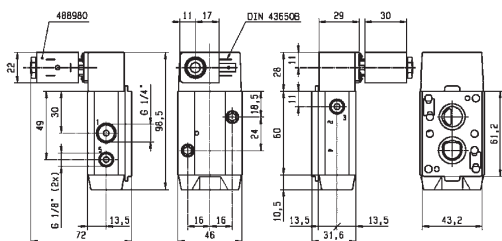

Drawing 7300

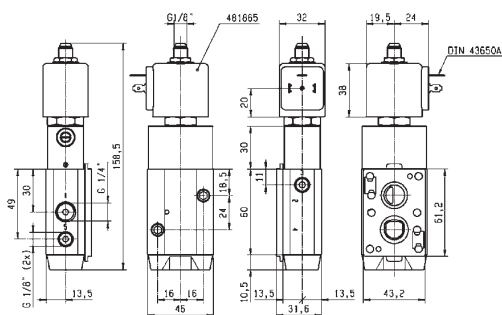

Drawing 7311



### 3 & 5 WAY PNEUMATIC DISTRIBUTORS

# 3/2-5/2

## 3 & 5 WAY PNEUMATIC VALVES FOR ACTUATOR CONTROL (NAMUR) PILOT OPERATED

ANODIZED ALUMINIUM  
NAMUR

SOLENOID OPERATED - SPRING RETURN

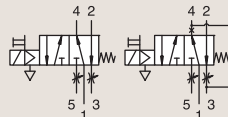

Port size BSP	Orifice Ø 1	Flow factor Qn l/min	Operating Pressure Differential			Fluid Temp.		Seat Seal	Parker LUCIFER® Valves			ATEX Zone	Protection Mode	Power		Coil Group	Dwg. No.
			Min bar	Max (MOPD) AC bar	DC bar	Min °C	Max °C		Valve Ref.	Housing Ref.	Coil Ref.			AC W	DC W		
1/8" 1/4"	4	600	2	10	10	-25	80	NBR	341N31 <sub>34</sub>	2995	481865	-	-	8	9	2.1	7295
	4	600	2	10	10	-25	80	NBR	341N31 <sub>34</sub>	2995	495870	2-22	Ex nAc nCc IIC T3/T4	8	9	2.1	7295
	4	600	2	10	10	-25	65	NBR	341N31 <sub>34</sub>	-	495905	1-21	Ex db mb IIC T4	8	8	2.1	7295
	4	600	2	10	10	-25	80	NBR	341N3102 <sub>4</sub>	2995	481865	-	-	8	9	2.1	7295
	4	600	2	10	10	-40	65	PUR	341N3108 <sub>3</sub>	2995	481865	-	-	8	9	2.1	7295
	4	600	2	10	10	-40	65	PUR	341N3108 <sub>3</sub>	4270	481000	-	-	8	8	2.1	7295
	4	600	2	10	10	-40	65	PUR	341N3128	2995	481865	-	-	8	9	2.1	7295
	4	600	2	10	10	-40	65	PUR	341N3128	4270	481865	-	-	8	9	2.1	7295
	4	600	2	-	10	-25	80	NBR	341N3130 <sub>134</sub>	2995	481865	-	-	-	9	2.1	7295
	4	600	2	-	10	-25	80	NBR	341N3130 <sub>134</sub>	-	492190	1-21	Ex eb mb IIC T3/T4	-	9	2.1	7295
	4	600	2	-	10	-25	80	NBR	341N3130 <sub>134</sub>	-	495905	1-21	Ex db mb IIC T4	-	8	2.1	7295
	4	600	2	-	10	-10	55	NBR	341N3190	2995	483580.01	0-20	Ex ia IIC T6	-	0.5 to 3	7.0/8.0	7349
	4	600	2	-	10	-10	75	NBR	341N3190	-	488660.01	0-20	Ex ia IIC T6	-	0.3 to 3	7.0/8.0	7349
	4	600	2	-	10	-10	75	NBR	341N3190	-	495910	0-20	Ex ia IIC T4 to T6	-	0.3 to 3	7.0/8.0	7349
	4	600	2	-	10	-25	65	NBR	341N3196 <sub>5</sub>	2995	482740	-	-	-	1.6	6.0/8.0	8017
	4	600	2	10	10	-25	65	NBR	341N3196 <sub>5</sub>	-	495900	1-21	Ex db mb IIC T4 to T6	2.5	2	6.0/8.0	8017
	4	600	2	-	10	-25	65	NBR	341N3196 <sub>5</sub>	-	495910	0-20	Ex ia IIC T4 to T6	-	0.3 to 3	6.0/8.0	8017
	4	600	2	-	10	-25	65	NBR	341N3196 <sub>5</sub>	2995	496125	2-22	Ex nAc nCc IIC T5/T6	-	1.6	6.0/8.0	8017
	4	600	2	-	10	-25	65	NBR	341N3197 <sub>35</sub>	2995	482740	-	-	-	1.6	6.0/8.0	8017
	4	600	2	10	10	-25	65	NBR	341N3197 <sub>35</sub>	-	495900	1-21	Ex db mb IIC T4 to T6	2.5	2	6.0/8.0	8017
4	600	2	-	10	-25	65	NBR	341N3197 <sub>35</sub>	-	495910	0-20	Ex ia IIC T4 to T6	-	0.3 to 3	6.0/8.0	8017	
4	600	2	-	10	-25	65	NBR	341N3197 <sub>35</sub>	2995	496125	2-22	Ex nAc nCc IIC T5/T6	-	1.6	6.0/8.0	8017	

**Notes:**

1. DC voltage only. Minimum drop off voltage is 15% of nominal voltage (former DIN 19251)
2. With captured exhaust
3. With manual override
4. Pilot seat in PKM
5. Pilot seat in PUR



### 3 & 5 WAY PNEUMATIC DISTRIBUTORS



For this page	Port size	Orifice (mm)	Qn (l/min)	MOPD (bar)	Fluid Temp (°C)	Amb Temp (°C)
From	1/8"-1/4"	4	600	10	-40	-25
To	1/8"-1/4"	4	600	10	80	50

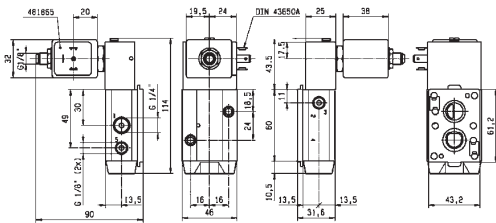

Drawing 7295

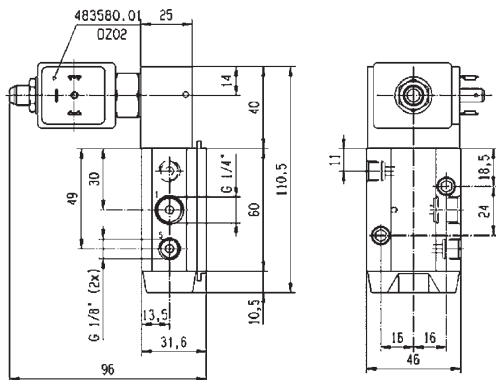

Drawing 7349

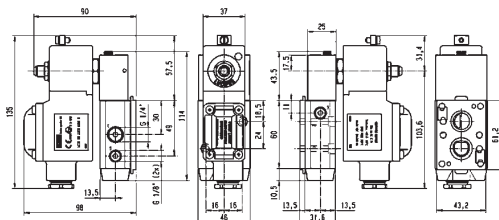

Drawing 8017



### 3 & 5 WAY PNEUMATIC DISTRIBUTORS

# 3/2-5/2

## 3 & 5 WAY PNEUMATIC VALVES FOR ACTUATOR CONTROL (NAMUR) PILOT OPERATED

ANODIZED ALUMINIUM  
NAMUR

SOLENOID OPERATED - SPRING RETURN

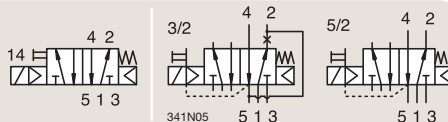

Port size BSP	Orifice Ø 1	Flow factor Qn l/min	Operating Pressure Differential			Fluid Temp.		Seat Seal	Parker LUCIFER® Valves			ATEX Zone	Protection Mode	Power		Coil Group	Dwg. No.
			Min	Max (MOPD)	DC bar	Min	Max		Valve Ref.	Housing Ref.	Coil Ref.			AC W	DC W		
1/8" 1/4"	8	1400	2	-	10	-25	55	NBR	341N3290	2995	483580.01	0-20	Ex ia IIC T6	-	0.5 to 3	7.0/8.0	7350
	8	1400	2	-	10	-25	75	NBR	341N3290	-	488660.01	0-20	Ex ia IIC T6	-	0.3 to 3	7.0/8.0	7350
	8	1400	2	-	10	-25	75	NBR	341N3290	-	495910	0-20	Ex ia IIC T4 to T6	-	0.3 to 3	7.0/8.0	7350
	8	1400	2	-	10	-20	80	NBR	341N3296	2995	482740	-	-	-	1.6	6.0/8.0	8029
	8	1400	2	10	10	-20	80	NBR	341N3296	-	495900	1-21	Ex db mb IIC T4 to T6	2.5	2	6.0/8.0	8029
	8	1400	2	-	10	-20	80	NBR	341N3296	-	495910	0-20	Ex ia IIC T4 to T6	-	0.3 to 3	6.0/8.0	8029
	8	1400	2	-	10	-20	80	NBR	341N3296	2995	496125	2-22	Ex nAc nCc IIC T5/T6	-	1.6	6.0/8.0	8029
	8	1400	2	-	10	-20	80	NBR	341N3297	2995	482740	-	-	-	1.6	6.0/8.0	8029
	8	1400	2	10	10	-20	80	NBR	341N3297	-	495900	1-21	Ex db mb IIC T4 to T6	2.5	2	6.0/8.0	8029
	8	1400	2	-	10	-20	80	NBR	341N3297	-	495910	0-20	Ex ia IIC T4 to T6	-	0.3 to 3	6.0/8.0	8029
1/4"	7	1250	2.5	10	10	-10	50	NBR	341N05	-	496131	-	-	3	3	1.2	8162
	7	1250	2.5	10	10	-10	50	NBR	341N05	-	496482	-	-	3	3	1.2	8162
	7	1250	2.5	10	10	-10	50	NBR	341N05	-	496637	22	Ex tc IIIC T95°C	3	3	1.2	8162

**Notes:**

1. With manual override





### 3 & 5 WAY PNEUMATIC DISTRIBUTORS

# 3/2-5/2

## 3 & 5 WAY PNEUMATIC VALVES FOR ACTUATOR CONTROL (NAMUR) PILOT OPERATED

ANODIZED ALUMINIUM  
NAMUR

SOLENOID OPERATED - SPRING RETURN

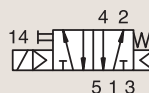

Port size	Orifice Ø	Flow factor	Operating Pressure Differential			Fluid Temp.		Seat Seal	Parker LUCIFER® Valves			ATEX Zone	Protection Mode		Power		Coil Group	Dwg. No.
			Min	Max (MOPD)	DC bar	Min	Max		Valve Ref.	Housing Ref.	Coil Ref.		AC W	DC W				
1/4"	7	1200	2.5	10	10	-10	50	NBR	341N0502	-	496131	-	-	3	3	1.2	8253	
	7	1200	2.5	10	10	-10	50	NBR	341N0502	-	496482	-	-	3	3	1.2	8253	
	7	1200	2.5	10	10	-10	50	NBR	341N35 <sub>2</sub>	2995	481865	-	-	8	9	2.1	8213	
	7	1200	2.5	10	10	-10	50	NBR	341N35 <sub>2</sub>	2995	495870	2-22	Ex nAc nCc IIC T3/T4	8	9	2.1	8213	
	7	1200	2.5	10	10	-10	50	NBR	341N35 <sub>2</sub>	-	495905	1-21	Ex db mb IIC T4	8	8	2.1	8213	
	7	1200	2.5	10	10	-10	50	NBR	341N3502	2995	481865	-	-	8	9	2.1	8254	
	7	1200	2.5	10	10	-10	50	NBR	341N3502	4270	481000	-	-	8	8	2.1	8254	
	8	1400	2	10	10	-25	80	NBR	341N02 <sub>12</sub>	8993	488980	-	-	2	2.5	1.1	7313	

#### Notes:

1. With captured exhaust
2. With manual override

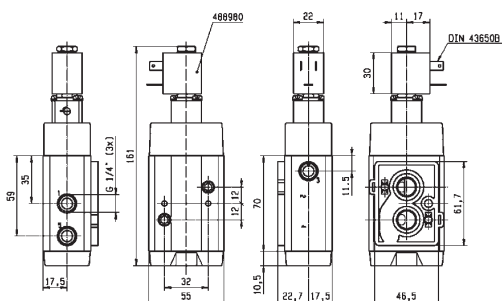

Drawing 7313



### 3 & 5 WAY PNEUMATIC DISTRIBUTORS



For this page	Port size	Orifice (mm)	Qn (l/min)	MOPD (bar)	Fluid Temp (°C)	Amb Temp (°C)
From	1/4"	7	1200	10	-25	-25
To	1/4"	8	1400	10	80	50

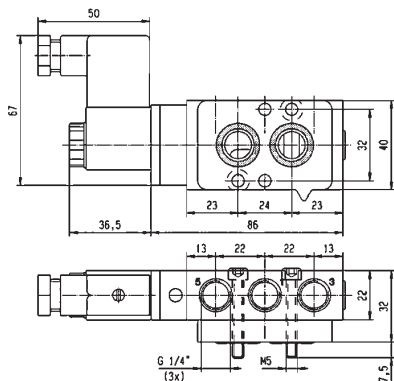

Drawing 8253

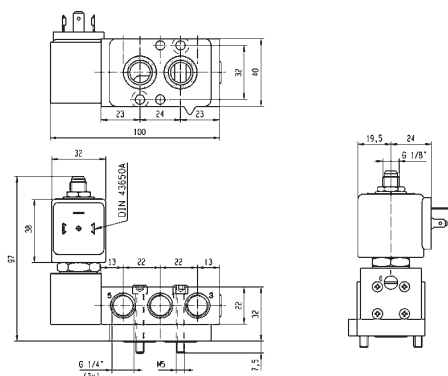

Drawing 8213

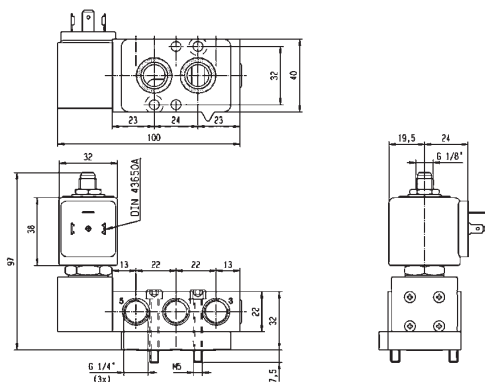

Drawing 8254



### 3 & 5 WAY PNEUMATIC DISTRIBUTORS

# 3/2-5/2

## 3 & 5 WAY PNEUMATIC VALVES FOR ACTUATOR CONTROL (NAMUR) PILOT OPERATED

ANODIZED ALUMINIUM  
NAMUR

SOLENOID OPERATED - SPRING RETURN

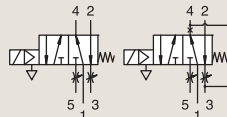

Port size	Orifice Ø	Flow factor	Operating Pressure Differential			Fluid Temp.		Seat Seal	Parker LUCIFER® Valves			ATEX Zone	Protection Mode	Power		Coil Group	Dwg. No.
			Min	Max (MOPD)	DC bar	Min	Max		Valve Ref.	Housing Ref.	Coil Ref.			AC W	DC W		
1/4"	8	1400	2	10	10	-25	80	NBR	341N12 <sub>12</sub>	8993	488980	-	-	2	2.5	1.1	7312
	8	1400	2	10	10	-25	80	NBR	341N22 <sub>2</sub>	2995	481865	-	-	8	9	2.1	7318
	8	1400	2	10	10	-25	80	NBR	341N22 <sub>2</sub>	4270	481000	-	-	8	8	2.1	7318
	8	1400	2	10	10	-25	80	NBR	341N32 <sub>2</sub>	2995	481865	-	-	8	9	2.1	7317
	8	1400	2	10	10	-25	80	NBR	341N32 <sub>2</sub>	2995	495870	2-22	Ex nAc nCc IIC T3/T4	8	9	2.1	7317
	8	1400	2	10	10	-25	80	NBR	341N32 <sub>2</sub>	-	495905	1-21	Ex db mb IIC T4	8	8	2.1	7317
	8	1400	2	10	10	-25	80	NBR	341N3202	2995	481865	-	-	8	9	2.1	7317
	8	1400	2	10	10	-25	80	NBR	341N3202	2995	495870	2-22	Ex nAc nCc IIC T3/T4	8	9	2.1	7317
8	1400	2	10	10	-25	80	NBR	341N3202	-	495905	1-21	Ex db mb IIC T4	8	8	2.1	7317	

**Notes:**

1. With captured exhaust
2. With manual override



### 3 & 5 WAY PNEUMATIC DISTRIBUTORS



For this page	Port size	Orifice (mm)	Qn (l/min)	MOPD (bar)	Fluid Temp (°C)	Amb Temp (°C)
From	1/4"	8	1400	10	-25	-25
To	1/4"	8	1400	10	80	50

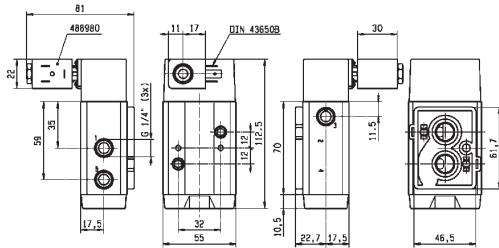

Drawing 7312

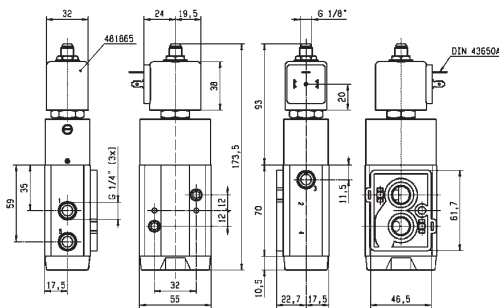

Drawing 7318

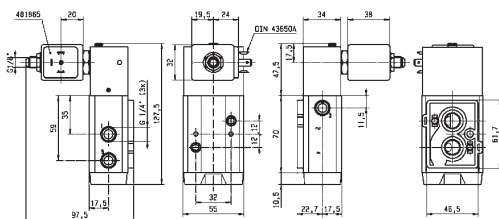

Drawing 7317



### 3 & 5 WAY PNEUMATIC DISTRIBUTORS

# 5/2

## 3 & 5 WAY PNEUMATIC VALVES FOR ACTUATOR CONTROL (NAMUR) PILOT OPERATED

ANODIZED ALUMINIUM  
NAMUR

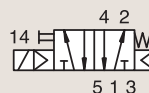

### SOLENOID OPERATED - SPRING RETURN

Port size	Orifice Ø	Flow factor	Operating Pressure Differential			Fluid Temp.		Seat Seal	Parker LUCIFER® Valves			ATEX Zone	Protection Mode	Power		Coil Group	Dwg. No.
			Min	Max (MOPD)	AC bar	DC bar	Min		Max	Valve Ref.	Housing Ref.			Coil Ref.	AC W		
1/4"	7	1250	2.5	10	10	-10	50	NBR	341N03 <sub>1</sub>	-	496131	-	-	3	3	1.2	8063
	7	1250	2.5	10	10	-10	50	NBR	341N03 <sub>1</sub>	-	496482	-	-	3	3	1.2	8063
	7	1250	2.5	10	10	-10	50	NBR	341N03 <sub>1</sub>	-	496637	22	Ex tc IIC T95°C	3	3	1.2	8063
1/2"	12	3000	2.5	10	10	-10	50	NBR	341N04 <sub>1</sub>	-	496131	-	-	3	3	1.2	8065
	12	3000	2.5	10	10	-10	50	NBR	341N04 <sub>1</sub>	-	496482	-	-	3	3	1.2	8065
	12	3000	2.5	10	10	-10	50	NBR	341N04 <sub>1</sub>	-	496637	22	Ex tc IIC T95°C	3	3	1.2	8065
	12	3000	2.5	10	10	-10	50	NBR	341N34 <sub>12</sub>	2995	481865	-	-	8	9	2.1	8211
	12	3000	2.5	10	10	-10	50	NBR	341N34 <sub>12</sub>	2995	495870	2-22	Ex nAc nCc IIC T3/T4	8	9	2.1	8211
	12	3000	2.5	10	10	-10	50	NBR	341N34 <sub>12</sub>	-	495905	1-21	Ex db mb IIC T4	8	8	2.1	8211

**Notes:**

1. With manual override
2. Pilot seat in FKM



### 3 & 5 WAY PNEUMATIC DISTRIBUTORS



For this page	Port size	Orifice (mm)	Qn (l/min)	MOPD (bar)	Fluid Temp (°C)	Amb Temp (°C)
From	1/4"	7	1250	10	-10	-10
To	1/2"	12	3000	10	50	50

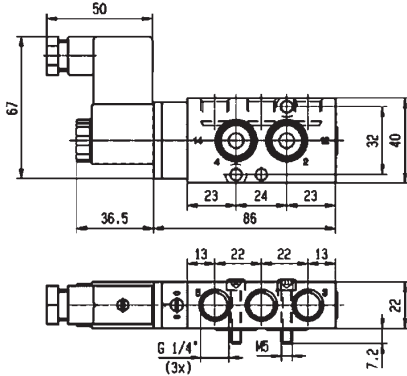

Drawing 8063

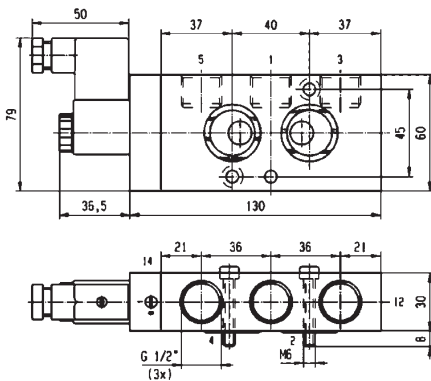

Drawing 8065

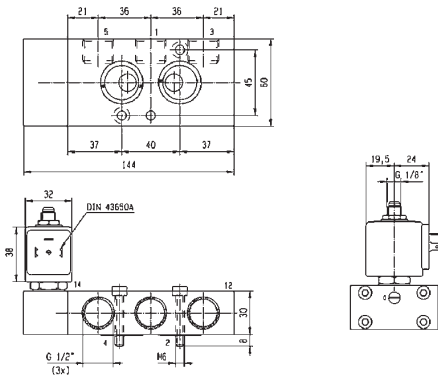

Drawing 8211



# 5/2

## 3 & 5 WAY PNEUMATIC VALVES FOR ACTUATOR CONTROL (NAMUR) PILOT OPERATED

ANODIZED ALUMINIUM  
NAMUR

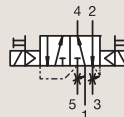

### DUAL SOLENOIDS

Port size BSP	Orifice Ø 1	Flow factor Qn l/min	Operating Pressure Differential			Fluid Temp.		Seat Seal	Parker LUCIFER® Valves			ATEX Zone	Protection Mode	Power		Coil Group	Dwg. No.
			Min	Max (MOPD)	DC	Min	Max		Valve Ref.	Housing Ref.	Coil Ref.			AC W	DC W		
1/8"- 1/4"	4	400	2	10	10	-25	50	NBR	347N11 <sub>123</sub>	-	482606	1-21	Ex mb IIC T4/T5	2	2.5	1.1	7305
	4	400	2	10	10	-25	80	NBR	347N11 <sub>123</sub>	8993	488980	-	-	2	2.5	1.1	7305
	4	400	2	10	10	-25	80	NBR	347N31 <sub>23</sub>	2995	481865	-	-	8	9	2.1	7297
	4	400	2	10	10	-25	80	NBR	347N31 <sub>23</sub>	2995	495870	2-22	Ex nAc nCc IIC T3/T4	8	9	2.1	7297
	4	400	2	10	10	-25	80	NBR	347N31 <sub>23</sub>	-	495905	1-21	Ex db mb IIC T4	8	8	2.1	7297
	4	400	2	-	10	-25	55	NBR	347N3190 <sub>3</sub>	2995	483580.01	0-20	Ex ia IIC T6	-	0.5 to 3	7.0/8.0	8141
	4	400	2	-	10	-25	65	NBR	347N3197 <sub>24</sub>	2995	482740	-	-	-	1.6	3.0/6.0/8.0	7297
	4	400	2	10	10	-25	65	NBR	347N3197 <sub>24</sub>	-	495900	1-21	Ex db mb IIC T4 to T6	2.5	2	3.0/6.0/8.0	7297
	4	400	2	-	10	-25	65	NBR	347N3197 <sub>24</sub>	-	495910	0-20	Ex ia IIC T4 to T6	-	0.3 to 3	3.0/6.0/8.0	7297
4	400	2	-	10	-25	65	NBR	347N3197 <sub>24</sub>	2995	496125	2-22	Ex nAc nCc IIC T5/T6	-	1.6	3.0/6.0/8.0	7297	

**Notes:**

1. With captured exhaust
2. With manual override
3. Pilot seat in FKM
4. Pilot seat in PUR

### 3 & 5 WAY PNEUMATIC DISTRIBUTORS



For this page	Port size	Orifice (mm)	Qn (l/min)	MOPD (bar)	Fluid Temp (°C)	Amb Temp (°C)
From	1/8"-1/4"	4	400	10	-25	-25
To	1/8"-1/4"	4	400	10	80	50

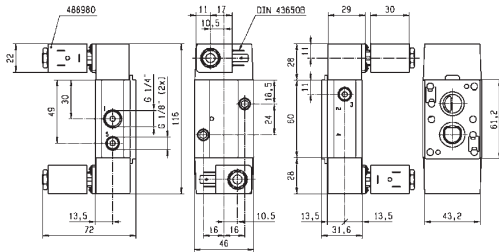

Drawing 7305

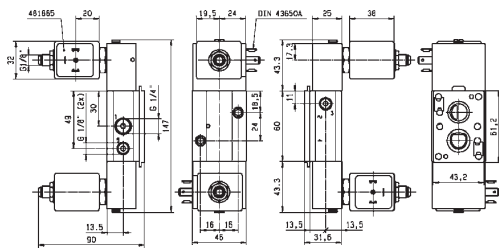

Drawing 7297

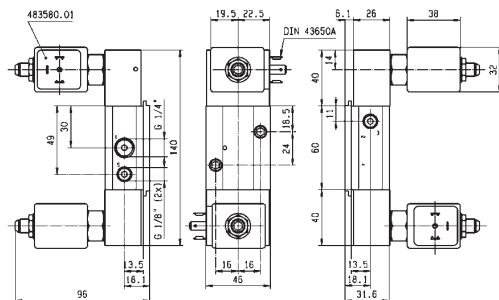

Drawing 8141



### 3 & 5 WAY PNEUMATIC DISTRIBUTORS

# 5/2

## 3 & 5 WAY PNEUMATIC VALVES FOR ACTUATOR CONTROL (NAMUR) PILOT OPERATED

### ANODIZED ALUMINIUM NAMUR

#### DUAL SOLENOIDS



Port size BSP	Orifice Ø 1	Flow factor Qn l/min	Operating Pressure Differential			Fluid Temp.		Seat Seal	Parker LUCIFER® Valves			ATEX Zone	Protection Mode	Power		Coil Group	Dwg. No.
			Min bar	Max (MOPD) AC bar	DC bar	Min °C	Max °C		Valve Ref.	Housing Ref.	Coil Ref.			AC W	DC W		
1/4"	7	1250	2.5	10	10	-10	50	NBR	347N03 <sub>2</sub>	-	496131	-	-	3	3	1.2	8057
	7	1250	2.5	10	10	-10	50	NBR	347N03 <sub>2</sub>	-	496482	-	-	3	3	1.2	8057
	7	1250	2.5	10	10	-10	50	NBR	347N03 <sub>2</sub>	-	496637	22	Ex tc IIC T95°C	3	3	1.2	8057
	7	1250	2.5	10	10	-10	50	NBR	347N33 <sub>3</sub>	2995	481865	-	-	8	9	2.1	8209
	7	1250	2.5	10	10	-10	50	NBR	347N33 <sub>3</sub>	2995	495870	2-22	Ex nAc nCc IIC T3/T4	8	9	2.1	8209
	7	1250	2.5	10	10	-10	50	NBR	347N33 <sub>3</sub>	-	495905	1-21	Ex db mb IIC T4	8	8	2.1	8209
	8	1400	2	10	10	-10	65	NBR	347N12 <sub>12</sub>	-	482606	1-21	Ex mb IIC T4/T5	2	2.5	1.1	7315
	8	1400	2	10	10	-25	80	NBR	347N12 <sub>12</sub>	8993	488980	-	-	2	2.5	1.1	7315
	8	1400	2	10	10	-25	80	NBR	347N32 <sub>23</sub>	2995	481865	-	-	8	9	2.1	7320
	8	1400	2	10	10	-25	80	NBR	347N32 <sub>23</sub>	2995	495870	2-22	Ex nAc nCc IIC T3/T4	8	9	2.1	7320
8	1400	2	10	10	-25	80	NBR	347N32 <sub>23</sub>	-	495905	1-21	Ex db mb IIC T4	8	8	2.1	7320	

#### Notes:

1. With captured exhaust
2. With manual override
3. Pilot seat in FKM

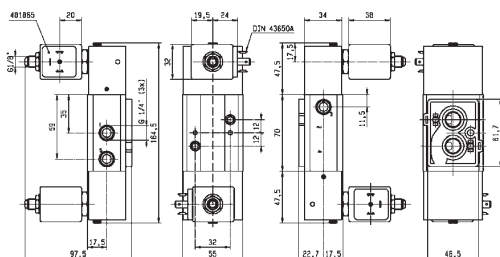

Drawing 7320



**3 & 5 WAY  
PNEUMATIC  
DISTRIBUTORS**



For this page	Port size	Orifice (mm)	Qn (l/min)	MOPD (bar)	Fluid Temp (°C)	Amb Temp (°C)
From	1/4"	7	1250	10	-25	-25
To	1/4"	8	1400	10	120	50

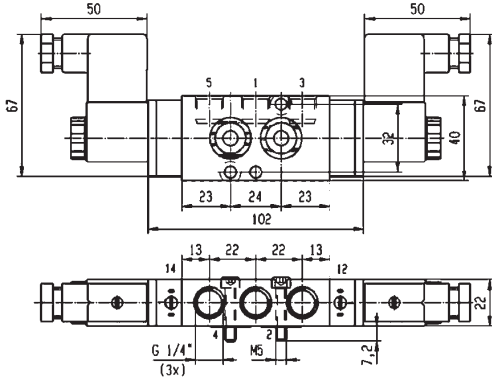

Drawing 8057

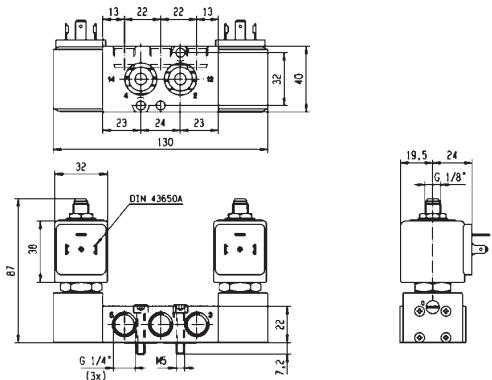

Drawing 8209

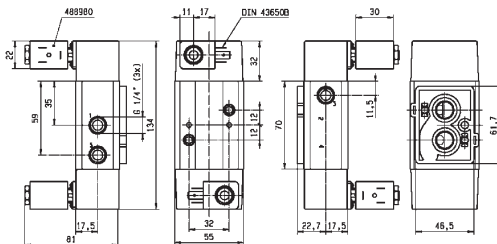

Drawing 7315



**3 & 5 WAY  
PNEUMATIC  
DISTRIBUTORS**

# 5/2

## 3 & 5 WAY PNEUMATIC VALVES FOR ACTUATOR CONTROL (NAMUR) PILOT OPERATED

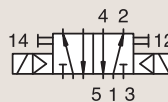
**ANODIZED ALUMINIUM  
NAMUR**

**DUAL SOLENOIDS**

Port size BSP	Orifice Ø 1	Flow factor Qn l/min	Operating Pressure Differential			Fluid Temp.		Seat Seal	Parker LUCIFER® Valves			ATEX Zone	Protection Mode	Power		Coil Group	Dwg. No.
			Min	Max (MOPD)	DC	Min	Max		Valve Ref.	Housing Ref.	Coil Ref.			AC W	DC W		
1/2"	12	3000	2.5	10	10	-10	50	NBR	347N04 <sub>1</sub>	-	496131	-	-	3	3	1.2	8154
	12	3000	2.5	10	10	-10	50	NBR	347N04 <sub>1</sub>	-	496482	-	-	3	3	1.2	8154
	12	3000	2.5	10	10	-10	50	NBR	347N04 <sub>1</sub>	-	496637	22	Ex tc IIC T95°C	3	3	1.2	8154
	12	3000	2.5	10	10	-10	50	NBR	347N34 <sub>12</sub>	2995	481865	-	-	8	9	2.1	8212
	12	3000	2.5	10	10	-10	50	NBR	347N34 <sub>12</sub>	2995	495870	2-22	Ex nAc nCc IIC T3/T4	8	9	2.1	8212
	12	3000	2.5	10	10	-10	50	NBR	347N34 <sub>12</sub>	-	495905	1-21	Ex db mb IIC T4	8	8	2.1	8212

**Notes:**

1. With manual override
2. Pilot seat in FKM



### 3 & 5 WAY PNEUMATIC DISTRIBUTORS



For this page	Port size	Orifice (mm)	Qn (l/min)	MOPD (bar)	Fluid Temp (°C)	Amb Temp (°C)
From	1/2"	12	3000	10	-10	-10
To	1/2"	12	3000	10	120	50

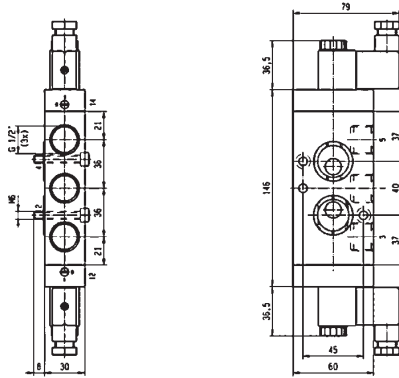

Drawing 8154

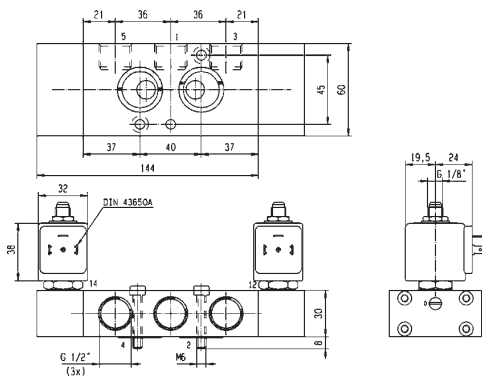

Drawing 8212

### 3 & 5 WAY PNEUMATIC DISTRIBUTORS

# 5/3

## 3 & 5 WAY PNEUMATIC VALVES FOR ACTUATOR CONTROL (NAMUR) PILOT OPERATED

### ANODIZED ALUMINIUM NAMUR

#### W1 CLOSED CENTER POSITION

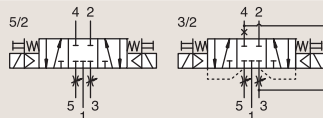

Port size	Orifice Ø	Flow factor	Operating Pressure Differential			Fluid Temp.		Seat Seal	Parker LUCIFER® Valves			ATEX Zone	Protection Mode	Power		Coil Group	Dwg. No.
			Min	Max (MOPD)	DC bar	Min	Max		Valve Ref.	Housing Ref.	Coil Ref.			AC W	DC W		
1/8"-1/4"	4	400	2	10	10	-25	80	NBR	342N11 <sub>12</sub>	-	482606	1-21	Ex mb IIC T4/T5	2	2.5	1.1	7305
	4	400	2	10	10	-25	80	NBR	342N11 <sub>12</sub>	8993	488980	-	-	2	2.5	1.1	7305
1/4"	4	400	2	-	10	-10	65	NBR	342N3197 <sub>2</sub>	-	495910	0-20	Ex ia IIC T4 to T6	-	0.3 to 3	6.0/8.0	7297
	7	1250	3	10	10	-10	50	NBR	342N03 <sub>2</sub>	-	496131	-	-	3	3	1.2	8057
	7	1250	3	10	10	-10	50	NBR	342N03 <sub>2</sub>	-	496482	-	-	3	3	1.2	8057
	7	1250	3	10	10	-10	50	NBR	342N03 <sub>2</sub>	-	496637	22	Ex tc IIIC T95°C	3	3	1.2	8057
	7	1250	2.5	10	10	-10	50	NBR	342N33 <sub>2</sub>	2995	481865	-	-	8	9	2.1	8209
	7	1250	2.5	10	10	-10	50	NBR	342N33 <sub>2</sub>	2995	495870	2-22	Ex nAc nCc IIC T3/T4	8	9	2.1	8209
	7	1250	2.5	10	10	-10	50	NBR	342N33 <sub>2</sub>	-	495905	1-21	Ex db mb IIC T4	8	8	2.1	8209

#### Notes:

1. With captured exhaust
2. With manual override

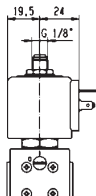
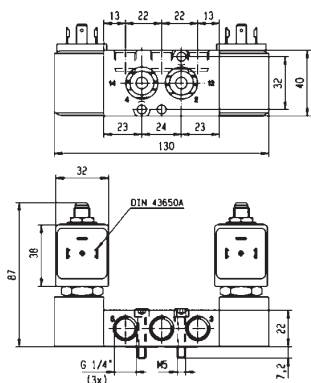

Drawing 8209



### 3 & 5 WAY PNEUMATIC DISTRIBUTORS



For this page	Port size	Orifice (mm)	Qn (l/min)	MOPD (bar)	Fluid Temp (°C)	Amb Temp (°C)
From	1/8"-1/4"	4	400	10	-25	-25
To	1/4"	7	1250	10	120	50

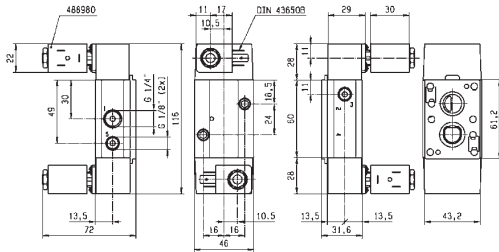

Drawing 7305

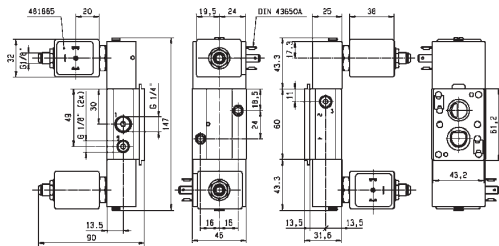

Drawing 7297

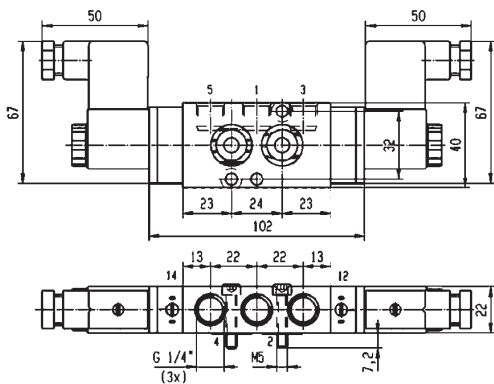

Drawing 8057



**3 & 5 WAY  
PNEUMATIC  
DISTRIBUTORS**

# 5/3

## 3 & 5 WAY PNEUMATIC VALVES FOR ACTUATOR CONTROL (NAMUR) PILOT OPERATED

ANODIZED ALUMINIUM  
NAMUR

**W3 EXHAUSTED IN CENTER POSITION**

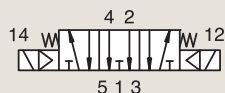

Port size	Orifice Ø	Flow factor	Operating Pressure Differential			Fluid Temp.		Seat Seal	Parker LUCIFER® Valves			ATEX Zone	Protection Mode	Power		Coil Group	Dwg. No.
			Min	Max (MOPD)	AC bar	DC bar	Min		Max	Valve Ref.	Housing Ref.			Coil Ref.	AC W		
BSP	1	Qn l/min	bar	bar	bar	°C	°C										
	7	1250	2.5	10	10	-10	50	NBR	343N03 <sub>1</sub>	-	496131	-	-	3	3	1.2	8057
1/4"	7	1250	2.5	10	10	-10	50	NBR	343N03 <sub>1</sub>	-	496482	-	-	3	3	1.2	8057
	7	1250	2.5	10	10	-10	50	NBR	343N03 <sub>1</sub>	-	496637	22	Ex tc IIIC T95°C	3	3	1.2	8057

**Notes:**

1. With manual override



### 3 & 5 WAY PNEUMATIC DISTRIBUTORS



For this page	Port size	Orifice (mm)	Qn (l/min)	MOPD (bar)	Fluid Temp (°C)	Amb Temp (°C)
From	1/4"	7	1250	10	-10	-10
To	1/4"	7	1250	10	50	50

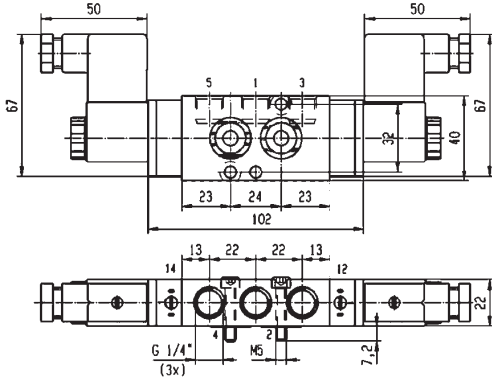

Drawing 8057

### 3 & 5 WAY PNEUMATIC DISTRIBUTORS

# 3/2-5/2

## 3 & 5 WAY PNEUMATIC VALVES FOR ACTUATOR CONTROL (NAMUR) PILOT OPERATED

ANODIZED ALUMINIUM  
NAMUR

CONTROL BY ELECTRIC IMPULSE

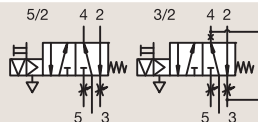

Port size	Orifice Ø	Flow factor	Operating Pressure Differential			Fluid Temp.		Seat Seal	Parker LUCIFER® Valves			ATEX Zone	Protection Mode	Power		Coil Group	Dwg. No.
			Min	Max (MOPD)	AC bar	DC bar	Min		Max	Valve Ref.	Housing Ref.			Coil Ref.	AC W		
BSP	mm	Qn l/min	bar	bar	bar	°C	°C										
1/8" 1/4"	4	600	2	-	10	-25	80	FKM/NBR	345N31 <sub>12</sub>	4269	485400	-	-	-	13	4.0	7295

**Notes:**

1. Pilot seat in FKM
2. With manual override

ANODIZED ALUMINIUM  
NAMUR

SOLENOID OPERATED - SPRING RETURN

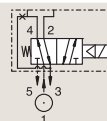

Port size	Orifice Ø	Flow factor	Operating Pressure Differential			Fluid Temp.		Seat Seal	Parker LUCIFER® Valves			ATEX Zone	Protection Mode	Power		Coil Group	Dwg. No.
			Min	Max (MOPD)	AC bar	DC bar	Min		Max	Valve Ref.	Housing Ref.			Coil Ref.	AC W		
BSP	mm	Qn l/min	bar	bar	bar	°C	°C										
1/8" 1/4"	4	355	1	10	10	-10	75	NBR	341L9504 <sub>12</sub>	-	482605	1-21	Ex mb IIC T4/T5	4	5	1.1	7009
	4	355	1	10	10	-10	75	NBR	341L9504 <sub>12</sub>	-	482606	1-21	Ex mb IIC T4/T5	2	2.5	1.1	7009
	4	355	1	10	10	-10	75	NBR	341L9504 <sub>12</sub>	8993	488980	-	-	2	2.5	1.1	7009
	4	355	1	10	10	-10	75	NBR	341L9504 <sub>12</sub>	8993	495865	2-22	Ex nAc nCc IIC T5	2	2.5	1.1	7009
	4	355	1	10	10	-10	75	NBR	341L9534 <sub>12</sub>	2995	481865	-	-	8	9	2.1/7.0	3990
	4	355	1	10	10	-10	75	NBR	341L9534 <sub>12</sub>	2995	495870	2-22	Ex nAc nCc IIC T3/T4	8	9	2.1/7.0	3990
	4	355	1	10	10	-10	75	NBR	341L9534 <sub>12</sub>	-	495905	1-21	Ex db mb IIC T4	8	8	2.1/7.0	3990

**Notes:**

1. Pilot seat in FKM
2. With manual override



### 3 & 5 WAY PNEUMATIC DISTRIBUTORS



For this page	Port size	Orifice (mm)	Qn (l/min)	MOPD (bar)	Fluid Temp (°C)	Amb Temp (°C)
From	1/8"-1/4"	4	355	10	-25	-25
To	1/8"-1/4"	4	600	10	80	50

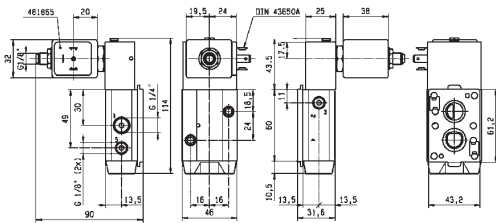

Drawing 7295

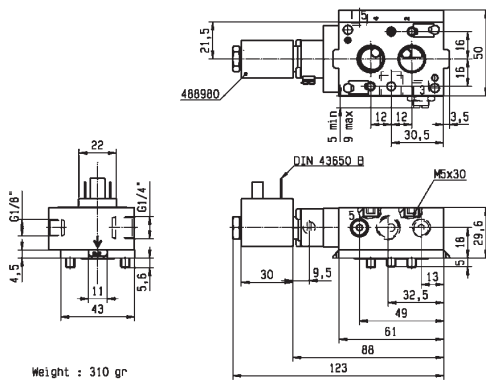

Drawing 7009

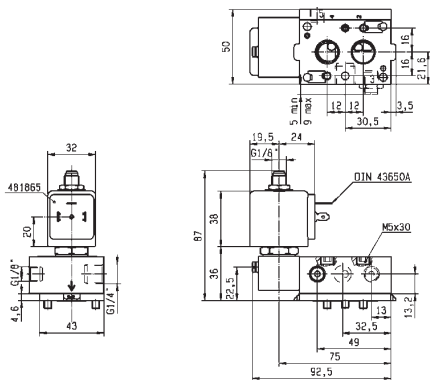

Drawing 3990

### 3 & 5 WAY PNEUMATIC DISTRIBUTORS

# 3/2-5/2

## 3 & 5 WAY PNEUMATIC VALVES FOR ACTUATOR CONTROL (NAMUR) PILOT OPERATED

ANODIZED ALUMINIUM  
NAMUR

SOLENOID OPERATED - SPRING RETURN

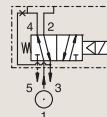

Port size BSP	Orifice Ø 1	Flow factor Qn l/min	Operating Pressure Differential			Fluid Temp.		Seat Seal	Parker LUCIFER® Valves			ATEX Zone	Protection Mode	Power		Coil Group	Dwg. No.
			Min	Max (MOPD)	DC	Min	Max		Valve Ref.	Housing Ref.	Coil Ref.			AC W	DC W		
1/8" 1/4"	4	355	2	-	10	-10	55	NBR	341L9594 <sub>12</sub>	2995	483580.01	0-20	Ex ia IIC T6	-	0.5 to 3	7.0	3992
	4	355	1	-	10	-10	75	NBR	341L9594 <sub>12</sub>	-	495910	0-20	Ex ia IIC T4 to T6	-	0.3 to 3	7.0	3992
	4	355	2	-	10	-10	75	NBR	341L9597 <sub>23</sub>	2995	482740	-	-	-	1.6	6.0/8.0	8025
	4	355	2	10	10	-10	75	NBR	341L9597 <sub>23</sub>	-	495900	1-21	Ex db mb IIC T4 to T6	2.5	2	6.0/8.0	8025
	4	355	2	-	10	-10	75	NBR	341L9597 <sub>23</sub>	-	495910	0-20	Ex ia IIC T4 to T6	-	0.3 to 3	6.0/8.0	8025
	4	355	2	-	10	-10	75	NBR	341L9597 <sub>23</sub>	2995	496125	2-22	Ex nAc nCc IIC T5/T6	-	1.6	6.0/8.0	8025
	4	355	2	-	10	-25	55	NBR	341L9598 <sub>3</sub>	2995	483580.01	0-20	Ex ia IIC T6	-	0.5 to 3	7.0	3992

**Notes:**

1. Pilot seat in FKM
2. With manual override
3. Pilot seat in PUR



### 3 & 5 WAY PNEUMATIC DISTRIBUTORS



For this page	Port size	Orifice (mm)	Qn (l/min)	MOPD (bar)	Fluid Temp (°C)	Amb Temp (°C)
From	1/8"-1/4"	4	355	10	-25	-10
To	1/8"-1/4"	4	355	10	75	50

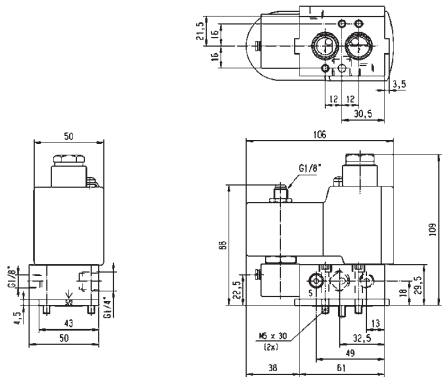

Drawing 3992

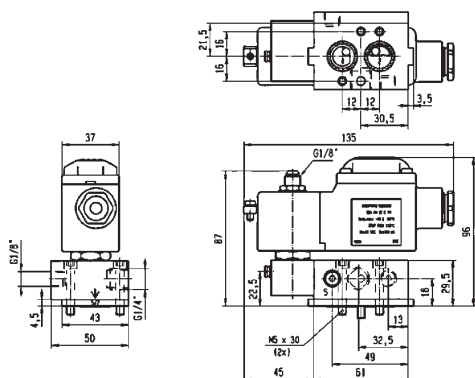

Drawing 8025

**3 & 5 WAY  
PNEUMATIC  
DISTRIBUTORS**

# 3/2

## 3 & 5 WAY PNEUMATIC VALVES FOR ACTUATOR CONTROL (NAMUR) EXTERNALLY OPERATED



Process

**ANODIZED ALUMINIUM  
NAMUR**

**AIR OPERATED - SPRING RETURN**

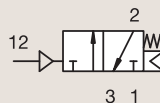

Port size	Orifice Ø 1	Flow factor Qn l/min	Operating Pressure Differential			Fluid Temp.		Seat Seal	Parker LUCIFER® Valves			ATEX Zone	Protection Mode	Power		Coil Group	Dwg. No.
			Min	Max (MOPD) AC bar	DC bar	Min	Max		Valve Ref.	Housing Ref.	Coil Ref.			AC W	DC W		
1/4"	7	1250	2.5	10	10	-10	50	NBR	531N03	-	-	-	-	-	-	-	8058
1/2"	12	3000	2.5	10	10	-10	50	NBR	531N04	-	-	-	-	-	-	-	8061



### 3 & 5 WAY PNEUMATIC DISTRIBUTORS



For this page	Port size	Orifice (mm)	Qn (l/min)	MOPD (bar)	Fluid Temp (°C)	Amb Temp (°C)
From	1/4"	7	1250	10	-10	-10
To	1/2"	12	3000	10	50	50

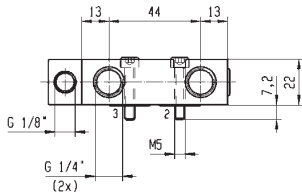
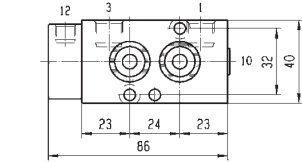

Drawing 8058

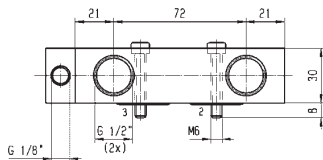
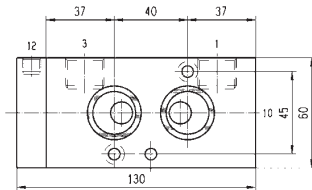

Drawing 8061

**3 & 5 WAY  
PNEUMATIC  
DISTRIBUTORS**

**3/2-5/2**

**3 & 5 WAY PNEUMATIC VALVES  
FOR ACTUATOR CONTROL (NAMUR)  
EXTERNALLY OPERATED**

**ANODIZED ALUMINIUM  
NAMUR**

**AIR OPERATED - SPRING RETURN**

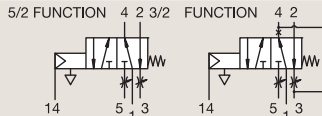

Port size	Orifice Ø	Flow factor	Operating Pressure Differential			Fluid Temp.		Seat Seal	Parker LUCIFER® Valves			ATEX Zone	Protection Mode	Power		Coil Group	Dwg. No.
			Min	Max (MOPD)	AC bar	DC bar	Min		Max	Valve Ref.	Housing Ref.			Coil Ref.	AC W		
BSP	1	Qn l/min	bar	AC bar	DC bar	°C	°C										
1/8"-1/4"	4	600	2	10	10	-25	80	NBR	541N01	-	-	-	-	-	-	-	7309
	4	600	2	10	10	-40	50	NBR	541N0108	-	-	-	-	-	-	-	7309



### 3 & 5 WAY PNEUMATIC DISTRIBUTORS



For this page	Port size	Orifice (mm)	Qn (l/min)	MOPD (bar)	Fluid Temp (°C)	Amb Temp (°C)
From	1/8"-1/4"	4	600	10	-40	-40
To	1/8"-1/4"	4	600	10	80	50

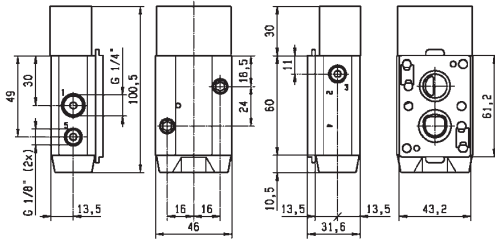

Drawing 7309

### 3 & 5 WAY PNEUMATIC DISTRIBUTORS

# 5/2

## 3 & 5 WAY PNEUMATIC VALVES FOR ACTUATOR CONTROL (NAMUR) EXTERNALLY OPERATED

ANODIZED ALUMINIUM  
NAMUR

5/2 FUNCTION

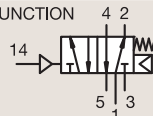

**AIR OPERATED - SPRING RETURN**

Port size	Orifice Ø	Flow factor	Operating Pressure Differential			Fluid Temp.		Seat Seal	Parker LUCIFER® Valves			ATEX Zone	Protection Mode	Power		Coil Group	Dwg. No.
			Min	Max (MOPD)	DC bar	Min	Max		Valve Ref.	Housing Ref.	Coil Ref.			AC W	DC W		
1/4"	7	1250	2.5	10	10	-10	50	NBR	541N03	-	-	-	-	-	-	-	8064
1/2"	12	3000	2.5	10	10	-10	50	NBR	541N04	-	-	-	-	-	-	-	8066

ANODIZED ALUMINIUM  
NAMUR

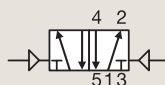

**AIR OPERATED AND RETURN**

Port size	Orifice Ø	Flow factor	Operating Pressure Differential			Fluid Temp.		Seat Seal	Parker LUCIFER® Valves			ATEX Zone	Protection Mode	Power		Coil Group	Dwg. No.
			Min	Max (MOPD)	DC bar	Min	Max		Valve Ref.	Housing Ref.	Coil Ref.			AC W	DC W		
1/4"	7	1250	2.5	10	10	-10	50	NBR	547N03	-	-	-	-	-	-	-	8059

### 3 & 5 WAY PNEUMATIC DISTRIBUTORS



For this page	Port size	Orifice (mm)	Qn (l/min)	MOPD (bar)	Fluid Temp (°C)	Amb Temp (°C)
From	1/4"	7	1250	10	-10	-10
To	1/2"	12	3000	10	50	50

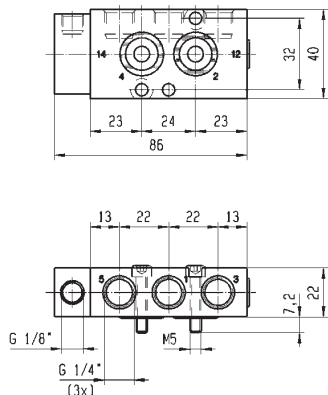

Drawing 8064

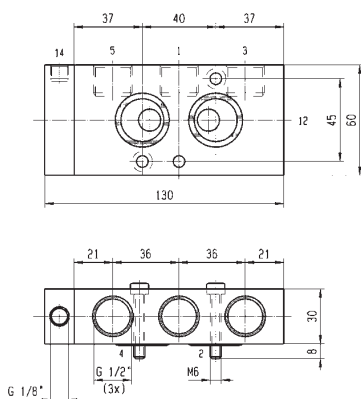

Drawing 8066

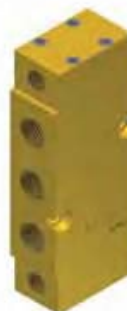
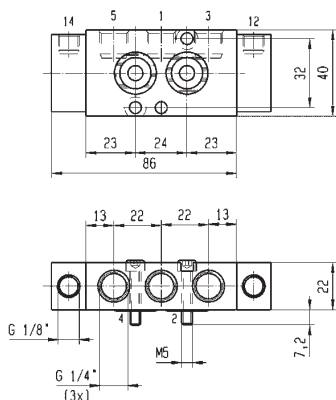

Drawing 8059

**3 & 5 WAY  
PNEUMATIC  
DISTRIBUTORS**

**5/3**

**3 & 5 WAY PNEUMATIC VALVES  
FOR ACTUATOR CONTROL (NAMUR)  
EXTERNALLY OPERATED**

**ANODIZED ALUMINIUM  
NAMUR**

**W1 CLOSED CENTER POSITION**

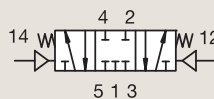

Port size BSP	Orifice Ø mm	Flow factor Qn l/min	Operating Pressure Differential		Fluid Temp.		Seat Seal	Parker LUCIFER® Valves			ATEX Zone	Protection Mode	Power		Coil Group	Dwg. No.
			Min bar	Max (MOPD) AC bar DC bar	Min °C	Max °C		Valve Ref.	Housing Ref.	Coil Ref.			AC W	DC W		
1/4"	7	1250	2.5	10 10	-10	50	NBR	542N03	-	-	-	-	-	-	-	8059



### 3 & 5 WAY PNEUMATIC DISTRIBUTORS



For this page	Port size	Orifice (mm)	Qn (l/min)	MOPD (bar)	Fluid Temp (°C)	Amb Temp (°C)
From	1/4"	7	1250	10	-10	-10
To	1/4"	7	1250	10	50	50

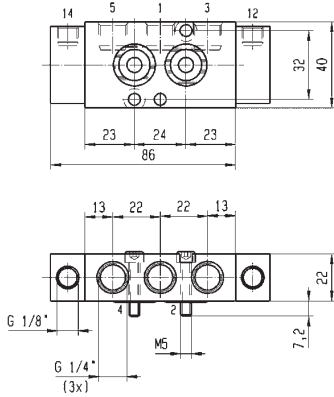

Drawing 8059

## 3 & 5 WAY PNEUMATIC DISTRIBUTORS FOR ACTUATION CONTROL

## 3 & 5 WAY PNEUMATIC DISTRIBUTORS FOR ACTUATION CONTROL



### 316L STAINLESS STEEL 3 & 5 WAY VALVES FOR ACTUATOR CONTROL (PIPE MOUNTING AND NAMUR)



**3/2**  
**5/2**

Actuation	Body	Function	Port Size	Orifice (mm)	Qn (l/min)	MOPD (bar)	Max Fluid Temp. (°C)	Page Parker Valves	Page Parker LUCIFER® Valves
Direct Operated	316L Stainless St./Pipe mounting	Universal	1/4"	2 to 6	680	12	80	-	376
			3/8"	6	680	10	75	-	382
	316L Stainless St./Sub-base mounting	Normally Closed	5 mm	2.5	220	14	80	-	384
			6 mm	2.5	220	10	75	-	384
		Universal	1/4"	6	680	10	65	-	384
	316L Stainless St./NAMUR	Normally Closed	3/8"	6	680	10	75	-	386
Pilot Operated	316L Stainless St./Pipe mounting	Normally Closed	3/8"	8	1400	10	80	-	388
	316L Stainless St./Pipe mounting/Spool	Normally Closed	3/8"	8	1400	10	80	-	388
		Dual Solenoids	3/8"	8	1400	10	80	-	392
	316L Stainless St./NAMUR/Spool	Normally Closed	3/8"-1/4"	8	1400	10	80	-	394
		Solenoid operated - spring return	3/8"-1/4"	8	1400	10	80	-	394
Manual Reset	316L Stainless St./Pipe mounting	Universal	1/4"	6	680	10	75	-	400
			3/8"	6	680	10	65	-	404

### 3 & 5 WAY PNEUMATIC DISTRIBUTORS

# 3/2

## 316L STAINLESS STEEL 3 & 5 WAY VALVES FOR ACTUATOR CONTROL (PIPE MOUNTING AND NAMUR) DIRECT OPERATED



Process

### 316L STAINLESS ST. PIPE MOUNTING

#### UNIVERSAL

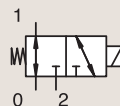

Port size	Orifice Ø 1	Flow factor Qn l/min	Operating Pressure Differential			Fluid Temp.		Seat Seal	Parker LUCIFER® Valves			ATEX Zone	Protection Mode	Power		Coil Group	Dwg. No.
			Min	Max (MOPD)	DC	Min	Max		Valve Ref.	Housing Ref.	Coil Ref.			AC W	DC W		
1/4" NPT	2	140	0	12	12	-25	65	FKM	U133V5595 <sub>1</sub>	-	492310	1-21	Ex eb mb II T3 to T6	6	6	9.0/10.1	6713
	2	140	0	-	12	-25	75	FKM	U133V5595 <sub>1</sub>	-	492965.01	0-20	Ex ia IIC T6	-	0.3 to 3	9.0/10.1	6713
	2	140	0	12	12	-25	65	FKM	U133V5595 <sub>1</sub>	-	496800	1-21	Ex db mb IIC T4	8	8	9.0/10.1	6713
	2	140	0	12	12	-25	80	FKM	U133V55951D <sub>1</sub>	-	483270.02	1-21	Ex db IIC T4 to T6	8	8	11.0	6714
	2	140	0	12	12	-25	65	FKM	U133V7595	-	492310	1-21	Ex eb mb II T3 to T6	6	6	9.0/10.1	8166
	2	140	0	-	12	-25	60	FKM	U133V7595	-	492965.01	0-20	Ex ia IIC T6	-	0.3 to 3	9.0/10.1	8166
	2	140	0	-	12	-25	65	FKM	U133V7595	-	496565	0-20	Ex ia IIC T4 to T6	-	0.3	9.0/10.1	8166
	2.5	220	0	-	8.5	-25	75	FKM	U133V5695 <sub>1</sub>	-	492210	1-21	Ex eb mb IIC T5/T6	-	1.8	9.0/10.1	6713
	2.5	220	0	-	8.5	-25	75	FKM	U133V5695 <sub>1</sub>	-	492965.01	0-20	Ex ia IIC T6	-	1.8	9.0/10.1	6713
	2.5	220	0	8.5	8.5	-25	75	FKM	U133V5695 <sub>1</sub>	-	496800	1-21	Ex db mb IIC T4	8	8	9.0/10.1	6713
	2.5	220	0	8.5	8.5	-10	75	FKM	U133V56951D <sub>12</sub>	-	483270.02	1-21	Ex db IIC T4 to T6	8	8	11.0	6714
	2.5	220	0	8.5	8.5	-25	75	FKM	U133V7695	-	492310	1-21	Ex eb mb II T3 to T6	6	6	9.0/10.1	8166
	2.5	220	0	-	8.5	-25	65	FKM	U133V7695	-	492965.01	0-20	Ex ia IIC T6	-	0.3 to 3	9.0/10.1	8166
	2.5	220	0	-	8.5	-25	65	FKM	U133V7695	-	496565	0-20	Ex ia IIC T4 to T6	-	0.3	9.0/10.1	8166

**Notes:**

1. Valve delivered with an individual material traceability certificate (3.1 following EN10204)
2. Valve only compatible with hydraulic oil and air/neutral gases



### 3 & 5 WAY PNEUMATIC DISTRIBUTORS



For this page	Port size	Orifice (mm)	Qn (l/min)	MOPD (bar)	Fluid Temp (°C)	Amb Temp (°C)
From	1/4"	2	140	8.5	-25	-25
To	1/4"	2.5	220	12	80	50

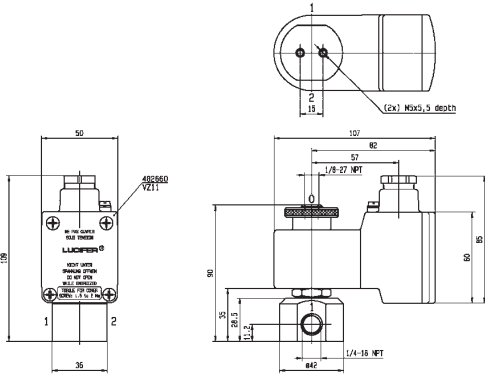

Drawing 6713

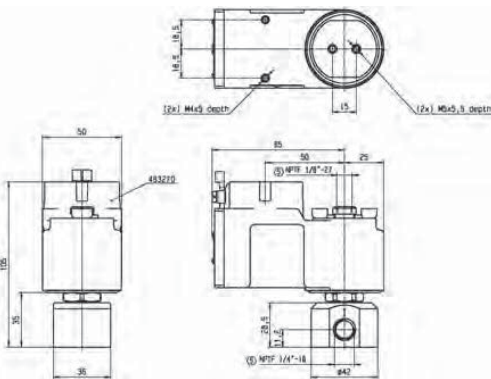

Drawing 6714

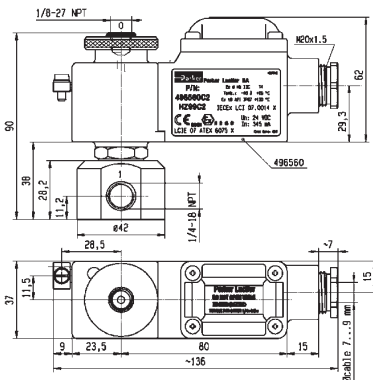

Drawing 8166

### 3 & 5 WAY PNEUMATIC DISTRIBUTORS

# 3/2

## 316L STAINLESS STEEL 3 & 5 WAY VALVES FOR ACTUATOR CONTROL (PIPE MOUNTING AND NAMUR) DIRECT OPERATED

### 316L STAINLESS ST. PIPE MOUNTING

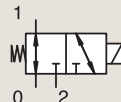

### UNIVERSAL

Port size	Orifice Ø	Flow factor	Operating Pressure Differential			Fluid Temp.		Seat Seal	Parker LUCIFER® Valves			ATEX Zone	Protection Mode	Power		Coil Group	Dwg. No.
			Min	Max (MOPD)	DC bar	Min	Max		Valve Ref.	Housing Ref.	Coil Ref.			AC W	DC W		
			bar	AC bar	°C	°C											
1/4" NPTF	6	680	0	10	10	-25	65	NBR	U133X5152 <sub>13</sub>	-	492310	1-21	Ex eb mb II T3 to T6	6	6	10.1/10.2	7770
	6	680	0	10	10	-25	65	NBR	U133X5152 <sub>13</sub>	-	496700	1-21	Ex db mb IIC T4 to T6	6	6	10.1/10.2	7770
	6	680	0	-	10	-25	65	NBR	U133X5156 <sub>23</sub>	-	492965.01	0-20	Ex ia IIC T6	-	0.3 to 3	9.0/10.1/10.2	7770
	6	680	0	10	10	-25	65	NBR	U133X5156 <sub>23</sub>	-	496700	1-21	Ex db mb IIC T4 to T6	6	6	9.0/10.1/10.2	7770
	6	680	0	10	10	-25	75	NBR	U133X515610 <sub>23</sub>	-	483270.02	1-21	Ex d IIC T4 to T6	8	8	11.0	7011
	6	680	0	10	10	-25	65	NBR	U133X5192 <sub>12</sub>	-	492310	1-21	Ex eb mb II T3 to T6	6	6	10.1	6904
	6	680	0	10	10	-25	65	NBR	U133X5192 <sub>12</sub>	-	496700	1-21	Ex db mb IIC T4 to T6	6	6	10.1	6904
	6	680	0	-	10	-25	65	NBR	U133X5196 <sub>2</sub>	-	492210	1-21	Ex eb mb IIC T5/T6	-	1.8	9.0/10.1/10.2	6904
	6	680	0	-	10	-25	65	NBR	U133X5196 <sub>2</sub>	-	492965.01	0-20	Ex ia IIC T6	-	0.3 to 3	9.0/10.1/10.2	6904
	6	680	0	10	10	-25	65	NBR	U133X5196 <sub>2</sub>	-	496700	1-21	Ex db mb IIC T4 to T6	6	6	9.0/10.1/10.2	6904

#### Notes:

- DC voltage only (or coil with rectifier). Minimum drop off voltage is 15% of nominal voltage (former DIN 19251)
- Valve delivered with an individual material traceability certificate (3.1 following EN10204)
- With manual override





### 3 & 5 WAY PNEUMATIC DISTRIBUTORS

# 3/2

## 316L STAINLESS STEEL 3 & 5 WAY VALVES FOR ACTUATOR CONTROL (PIPE MOUNTING AND NAMUR) DIRECT OPERATED

### 316L STAINLESS ST. PIPE MOUNTING

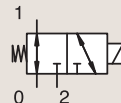

### UNIVERSAL

Port size	Orifice Ø	Flow factor	Operating Pressure Differential			Fluid Temp.		Seat Seal	Parker LUCIFER® Valves			ATEX Zone	Protection Mode	Power		Coil Group	Dwg. No.
			Min	Max (MOPD)	DC bar	Min	Max		Valve Ref.	Housing Ref.	Coil Ref.			AC W	DC W		
			bar	AC bar	DC bar	°C	°C										
1/4" NPTF	6	680	0	10	10	-25	65	NBR	U133X51961D <sub>1</sub>	-	483270.02	1-21	Ex db IIC T4 to T6	8	8	11.0	7038
	6	680	0	10	10	-25	65	NBR	U133X7156 <sub>2</sub>	-	496700	1-21	Ex db mb IIC T4 to T6	6	6	9.0/10.1/10.2	8168
	6	680	0	-	10	-25	65	NBR	U133X7196	-	492210	1-21	Ex eb mb IIC T5/T6	-	1.8	9.0/10.1/10.2	8169
	6	680	0	-	10	-25	65	NBR	U133X7196	-	492965.01	0-20	Ex ia IIC T6	-	0.3 to 3	9.0/10.1/10.2	8169
	6	680	0	10	10	-25	65	NBR	U133X7196	-	496700	1-21	Ex db mb IIC T4 to T6	6	6	9.0/10.1/10.2	8169

#### Notes:

1. Valve delivered with an individual material traceability certificate (3.1 following EN10204)
2. With manual override



### 3 & 5 WAY PNEUMATIC DISTRIBUTORS



For this page	Port size	Orifice (mm)	Qn (l/min)	MOPD (bar)	Fluid Temp (°C)	Amb Temp (°C)
From	1/4"	6	680	10	-25	-25
To	1/4"	6	680	10	65	65

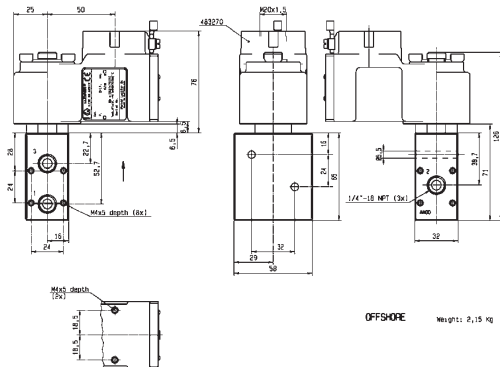

Drawing 7038

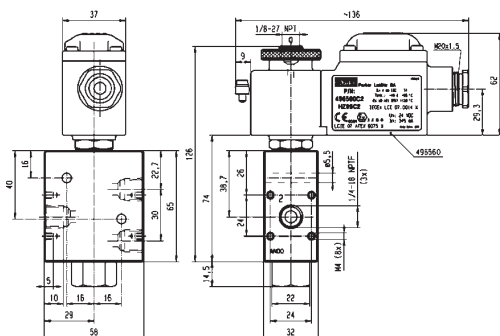

Drawing 8168

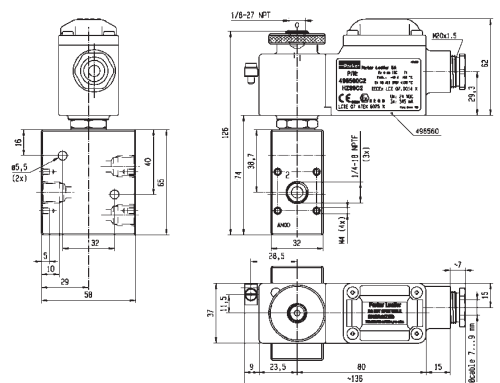

Drawing 8169



### 3 & 5 WAY PNEUMATIC DISTRIBUTORS

# 3/2

## 316L STAINLESS STEEL 3 & 5 WAY VALVES FOR ACTUATOR CONTROL (PIPE MOUNTING AND NAMUR) DIRECT OPERATED

### 316L STAINLESS ST. PIPE MOUNTING

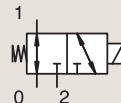

### UNIVERSAL

Port size	Orifice Ø	Flow factor	Operating Pressure Differential			Fluid Temp.		Seat Seal	Parker LUCIFER® Valves			ATEX Zone	Protection Mode	Power		Coil Group	Dwg. No.
			Min	Max (MOPD)	DC	Min	Max		Valve Ref.	Housing Ref.	Coil Ref.			AC W	DC W		
			bar	AC bar	DC bar	°C	°C										
3/8" NPTF	6	680	0	10	10	-25	65	NBR	U133X5296 <sub>1</sub>	-	492310	1-21	Ex eb mb II T3 to T6	6	6	9.0/10.1/10.2	7669
	6	680	0	-	10	-25	65	NBR	U133X5296 <sub>1</sub>	-	492965.01	0-20	Ex ia IIC T6	-	0.3 to 3	9.0/10.1/10.2	7669
	6	680	0	10	10	-25	65	NBR	U133X5296 <sub>1</sub>	-	496700	1-21	Ex db mb IIC T4 to T6	6	6	9.0/10.1/10.2	7669
	6	680	0	10	10	-25	75	NBR	U133X52961D <sub>1</sub>	-	483270.02	1-21	Ex db IIC T4 to T6	8	8	11.0	7670

#### Notes:

1. Valve delivered with an individual material traceability certificate (3.1 following EN10204)







### 3 & 5 WAY PNEUMATIC DISTRIBUTORS



For this page	Port size	Orifice (mm)	Qn (l/min)	MOPD (bar)	Fluid Temp (°C)	Amb Temp (°C)
From	SB	2.5	220	10	-25	-25
To	SB	6	680	14	80	50

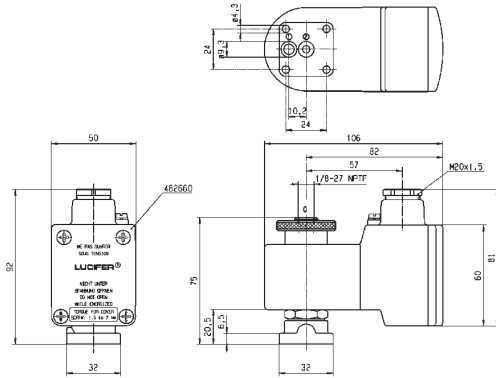

Drawing 3782

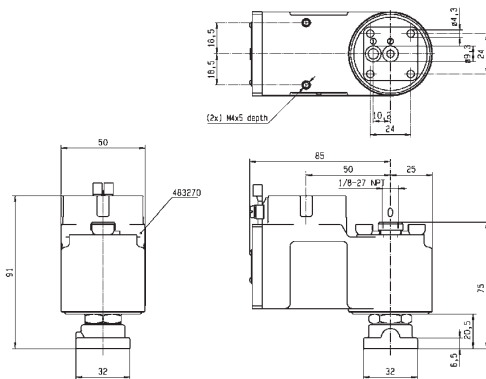

Drawing 3783

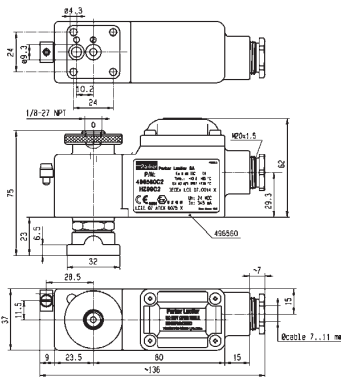

Drawing 8174

### 3 & 5 WAY PNEUMATIC DISTRIBUTORS

# 3/2

## 316L STAINLESS STEEL 3 & 5 WAY VALVES FOR ACTUATOR CONTROL (PIPE MOUNTING AND NAMUR) DIRECT OPERATED

### 316L STAINLESS ST. SUB-BASE MOUNTING

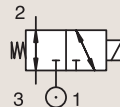

#### UNIVERSAL

Port size	Orifice Ø 1	Flow factor Qn l/min	Operating Pressure Differential			Fluid Temp.		Seat Seal	Parker LUCIFER® Valves			ATEX Zone	Protection Mode	Power		Coil Group	Dwg. No.
			Min	Max (MOPD)	DC bar	Min	Max		Valve Ref.	Housing Ref.	Coil Ref.			AC W	DC W		
1/4" NPTF	6	680	0	10	10	-25	65	FKM	U133X51951D <sub>1</sub>	-	483270	1-21	Ex db IIC T4 to T6	8	8	11.0	3688
	6	680	0	10	10	-25	65	FKM	U133X51951D <sub>1</sub>	-	483270.02	1-21	Ex db IIC T4 to T6	8	8	11.0	3688
	6	680	0	-	10	-25	65	FKM	U133X7195	-	492210	1-21	Ex eb mb IIC T5/T6	-	1.8	9.0/10.1/10.2	8172
	6	680	0	-	10	-25	65	FKM	U133X7195	-	492965.01	0-20	Ex ia IIC T6	-	0.3 to 3	9.0/10.1/10.2	8172
	6	680	0	10	10	-25	65	FKM	U133X7195	-	496700	1-21	Ex db mb IIC T4 to T6	6	6	9.0/10.1/10.2	8172

#### Notes:

1. Valve delivered with an individual material traceability certificate (3.1 following EN10204)

### 316L STAINLESS ST. NAMUR

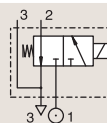

#### NORMALLY CLOSED

Port size	Orifice Ø 1	Flow factor Qn l/min	Operating Pressure Differential			Fluid Temp.		Seat Seal	Parker LUCIFER® Valves			ATEX Zone	Protection Mode	Power		Coil Group	Dwg. No.
			Min	Max (MOPD)	DC bar	Min	Max		Valve Ref.	Housing Ref.	Coil Ref.			AC W	DC W		
3/8" NPT	6	680	0	10	10	-25	65	NBR	U131X1201 <sub>1</sub>	-	492310	1-21	Ex eb mb II T3 to T6	6	6	9.0/10.1/10.2	7668
	6	680	0	-	10	-25	75	NBR	U131X1201 <sub>1</sub>	-	492965.01	0-20	Ex ia IIC T6	-	0.3 to 3	9.0/10.1/10.2	7668
	6	680	0	10	10	-25	65	NBR	U131X1201 <sub>1</sub>	-	496700	1-21	Ex db mb IIC T4 to T6	6	6	9.0/10.1/10.2	7668

#### Notes:

1. Valve delivered with an individual material traceability certificate (3.1 following EN10204)

### 3 & 5 WAY PNEUMATIC DISTRIBUTORS



For this page	Port size	Orifice (mm)	Qn (l/min)	MOPD (bar)	Fluid Temp (°C)	Amb Temp (°C)
From	1/4"	6	680	10	-25	-25
To	3/8"	6	680	10	75	65

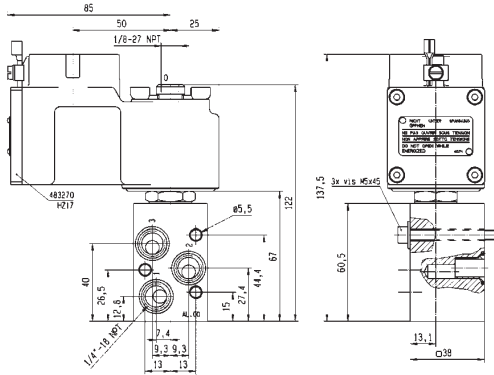

Drawing 3688

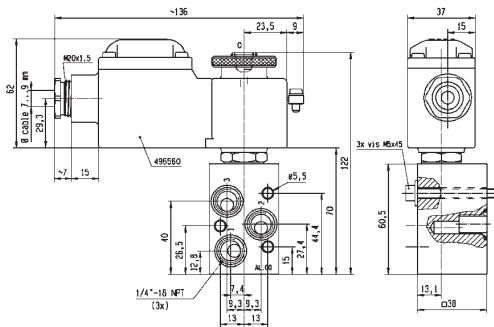

Drawing 8172

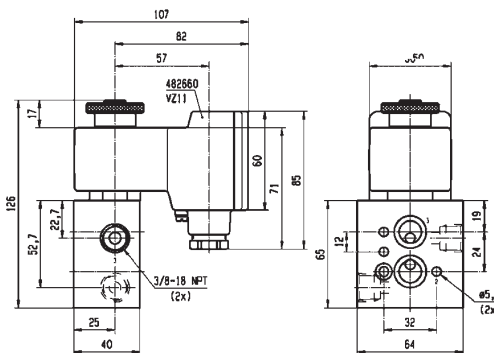

Drawing 7668



### 3 & 5 WAY PNEUMATIC DISTRIBUTORS

# 5/2

## 316L STAINLESS STEEL 3 & 5 WAY VALVES FOR ACTUATOR CONTROL (PIPE MOUNTING AND NAMUR) PILOT OPERATED



Process

### 316L STAINLESS ST. PIPE MOUNTING

#### NORMALLY CLOSED

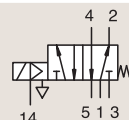

Port size	Orifice Ø 1 mm	Flow factor Qn l/min	Operating Pressure Differential		Fluid Temp.		Seat Seal	Parker LUCIFER® Valves			ATEX Zone	Protection Mode	Power		Coil Group	Dwg. No.
			Min bar	Max (MOPD) AC bar DC bar	Min °C	Max °C		Valve Ref.	Housing Ref.	Coil Ref.			AC W	DC W		
3/8" NPT	8	1400	2	10 10	-25	80	NBR	U441P3250 <sub>12</sub>	4270	481000	-	-	8	8	2.1	7565
	8	1400	2	10 10	-25	80	NBR	U441P3250 <sub>12</sub>	2995	481865	-	-	8	9	2.1	7565

**Notes:**

1. Pilot seat in FKM
2. Valve with external pilot pressure minimum 4 bar

### 316L STAINLESS ST. PIPE MOUNTING

#### NORMALLY CLOSED

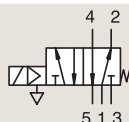

Port size	Orifice Ø 1 mm	Flow factor Qn l/min	Operating Pressure Differential		Fluid Temp.		Seat Seal	Parker LUCIFER® Valves			ATEX Zone	Protection Mode	Power		Coil Group	Dwg. No.
			Min bar	Max (MOPD) AC bar DC bar	Min °C	Max °C		Valve Ref.	Housing Ref.	Coil Ref.			AC W	DC W		
1/4" NPT	8	1400	2	10 10	-25	80	NBR	U341P0250 <sub>123</sub>	8993	481045	-	-	2	2.5	1.1	7578
	8	1400	2	10 10	-25	80	NBR	U341P0250 <sub>123</sub>	-	482606	1-21	Ex mb IIC T4/T5	2	2.5	1.1	7578
1/4" NPT	8	1400	2	10 10	-25	80	NBR	U341P3250 <sub>1</sub>	4270	481000	-	-	8	8	2.1	7558
	8	1400	2	10 10	-25	80	NBR	U341P3250 <sub>1</sub>	2995	481865	-	-	8	9	2.1	7558
	8	1400	2	10 10	-25	80	NBR	U341P3250 <sub>1</sub>	2995	492453	-	-	8	9	2.1	7558

**Notes:**

1. Pilot seat in FKM
2. With captured exhaust
3. With manual override



### 3 & 5 WAY PNEUMATIC DISTRIBUTORS



For this page	Port size	Orifice (mm)	Qn (l/min)	MOPD (bar)	Fluid Temp (°C)	Amb Temp (°C)
From	3/8"	8	1400	10	-25	-25
To	3/8"	8	1400	10	80	50

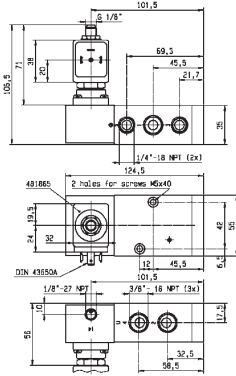

Drawing 7565

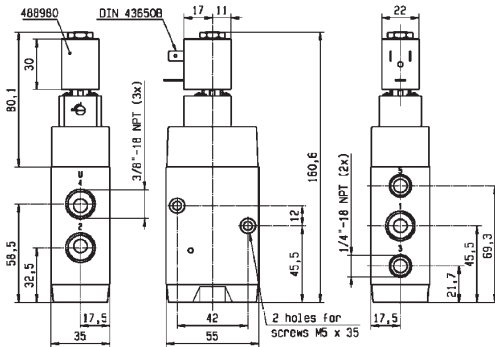

Drawing 7578

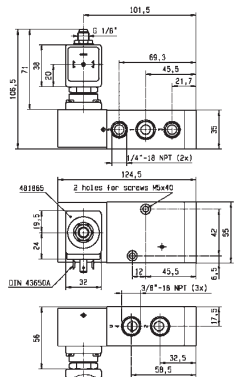

Drawing 7558



**3 & 5 WAY  
PNEUMATIC  
DISTRIBUTORS**

# 5/2

316L STAINLESS STEEL 3 & 5 WAY VALVES  
FOR ACTUATOR CONTROL (PIPE MOUNTING AND NAMUR)  
PILOT OPERATED

316L STAINLESS ST.  
PIPE MOUNTING

**NORMALLY CLOSED**

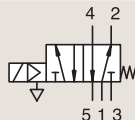

Port size	Orifice Ø 1	Flow factor Qn l/min	Operating Pressure Differential			Fluid Temp.		Seat Seal	Parker LUCIFER® Valves			ATEX Zone	Protection Mode	Power		Coil Group	Dwg. No.
			Min	Max (MOPD)	DC	Min	Max		Valve Ref.	Housing Ref.	Coil Ref.			AC W	DC W		
3/8" NPT	8	1400	2	-	10	-25	55	NBR	U341P3292 <sub>1</sub>	2995	483580.01	0-20	Ex ia IIC T6	-	0.5 to 3	7.0	7560
	8	1400	2	10	10	-25	75	NBR	U341P3295 <sub>1</sub>	-	492310	1-21	Ex eb mb II T3 to T6	6	6	9.0/10.1	7561
	8	1400	2	-	10	-25	75	NBR	U341P3295 <sub>1</sub>	-	492965.01	0-20	Ex ia IIC T6	-	0.3 to 3	9.0/10.1	7561

**Notes:**

1. Pilot seat in FKM



### 3 & 5 WAY PNEUMATIC DISTRIBUTORS



For this page	Port size	Orifice (mm)	Qn (l/min)	MOPD (bar)	Fluid Temp (°C)	Amb Temp (°C)
From	3/8"11	8	1400	10	-25	-25
To	3/8"11	8	1400	10	75	50

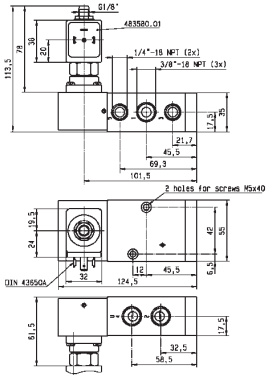

Drawing 7560

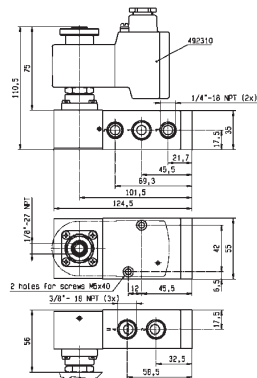

Drawing 7561

### 3 & 5 WAY PNEUMATIC DISTRIBUTORS

# 5/2

## 316L STAINLESS STEEL 3 & 5 WAY VALVES FOR ACTUATOR CONTROL (PIPE MOUNTING AND NAMUR) PILOT OPERATED

### 316L STAINLESS ST. PIPE MOUNTING

#### DUAL SOLENOIDS

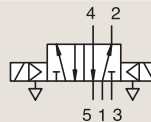

Port size	Orifice Ø	Flow factor	Operating Pressure Differential			Fluid Temp.		Seat Seal	Parker LUCIFER® Valves			ATEX Zone	Protection Mode	Power		Coil Group	Dwg. No.
			Min	Max (MOPD)		Min	Max		Valve Ref.	Housing Ref.	Coil Ref.			AC W	DC W		
			bar	AC bar	DC bar	°C	°C										
3/8" NPT	8	1400	2	10	10	-25	80	NBR	U347P3250 <sub>1</sub>	4270	481000	-	-	8	8	2.1	7563
	8	1400	2	10	10	-25	80	NBR	U347P3250 <sub>1</sub>	-	483371	1-21	Ex eb IIC T4	8	8	2.1	7563
	8	1400	2	10	10	-25	75	NBR	U347P3295 <sub>1</sub>	-	492310	1-21	Ex eb mb II T3 to T6	6	6	9.0/10.1	7564
	8	1400	2	10	10	-25	75	NBR	U347P3295 <sub>1</sub>	-	496800	1-21	Ex db mb IIC T4	8	8	9.0/10.1	7564

#### Notes:

1. Pilot seat in FKM



### 3 & 5 WAY PNEUMATIC DISTRIBUTORS



For this page	Port size	Orifice (mm)	Qn (l/min)	MOPD (bar)	Fluid Temp (°C)	Amb Temp (°C)
From	3/8"	8	1400	10	-25	-25
To	3/8"	8	1400	10	80	50

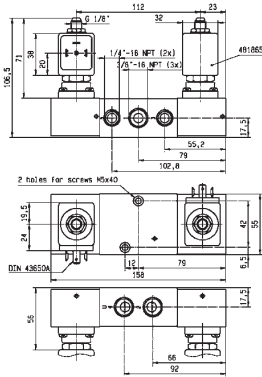

Drawing 7563

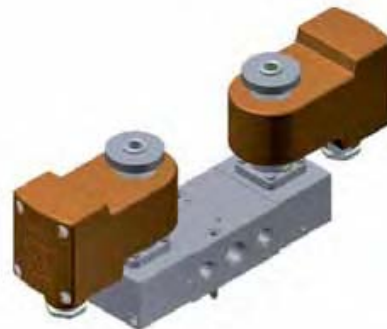
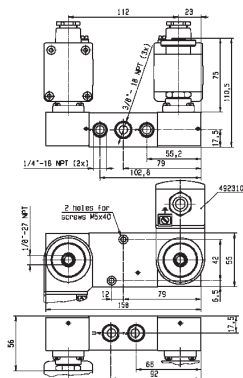

Drawing 7564

### 3 & 5 WAY PNEUMATIC DISTRIBUTORS

# 3/2-5/2

## 316L STAINLESS STEEL 3 & 5 WAY VALVES FOR ACTUATOR CONTROL (PIPE MOUNTING AND NAMUR) PILOT OPERATED

### 316L STAINLESS ST.

### NAMUR

### NORMALLY CLOSED

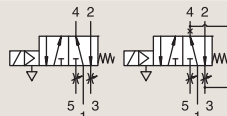

Port size	Orifice Ø	Flow factor	Operating Pressure Differential			Fluid Temp.		Seat Seal	Parker LUCIFER® Valves			ATEX Zone	Protection Mode	Power		Coil Group	Dwg. No.
			Min	Max (MOPD)		Min	Max		Valve Ref.	Housing Ref.	Coil Ref.			AC W	DC W		
			bar	AC bar	DC bar	°C	°C										
3/8"- 1/4" NPT	8	1400	2	10	10	-25	80	NBR	U341N3250	2995	481865	-	-	8	9	2.1	7554
	8	1400	2	10	10	-25	80	NBR	U341N3250	-	492190	1-21	Ex eb mb IIC T3/T4	11	9	2.1	7554
	8	1400	2	-	10	-25	55	NBR	U341N3292	2995	483580.01	0-20	Ex ia IIC T6	-	0.5 to 3	7.0	7556
	8	1400	2	10	10	-25	75	NBR	U341N3295	-	492310	1-21	Ex eb mb II T3 to T6	6	6	9.0/10.1	7696
	8	1400	2	10	10	-25	75	NBR	U341N3295	-	496800	1-21	Ex db mb IIC T4	8	8	9.0/10.1	7696

#### Notes:

1. Pilot seat in FKM



### 3 & 5 WAY PNEUMATIC DISTRIBUTORS



For this page	Port size	Orifice (mm)	Qn (l/min)	MOPD (bar)	Fluid Temp (°C)	Amb Temp (°C)
From	3/8"-1/4"	8	1400	10	-25	-25
To	3/8"-1/4"	8	1400	10	80	50

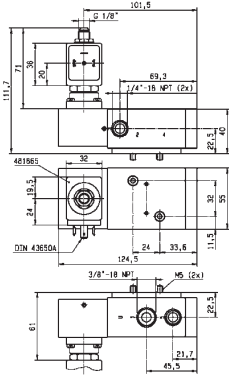

Drawing 7554

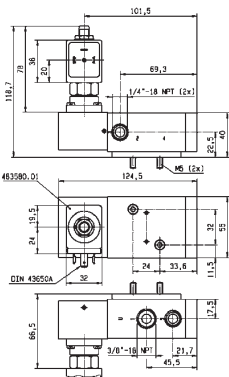

Drawing 7556

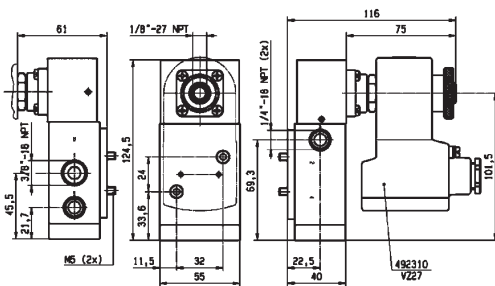

Drawing 7696



### 3 & 5 WAY PNEUMATIC DISTRIBUTORS

# 3/2-5/2

## 316L STAINLESS STEEL 3 & 5 WAY VALVES FOR ACTUATOR CONTROL (PIPE MOUNTING AND NAMUR) PILOT OPERATED

316L STAINLESS ST.  
NAMUR

**SOLENOID OPERATED - SPRING RETURN**

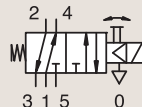

Port size	Orifice Ø 1 mm	Flow factor Qn l/min	Operating Pressure Differential			Fluid Temp.		Seat Seal	Parker LUCIFER® Valves			ATEX Zone	Protection Mode	Power		Coil Group	Dwg. No.
			Min bar	Max (MOPD) AC bar	DC bar	Min °C	Max °C		Valve Ref.	Housing Ref.	Coil Ref.			AC W	DC W		
3/8"- 1/4"NPT	8	1400	2	10	10	-25	80	NBR	U341N0250 <sub>123</sub>	-	482606	1-21	Ex mb IIC T4/T5	2	2.5	1.1	7577
	8	1400	2	10	10	-25	80	NBR	U341N0250 <sub>123</sub>	8993	488980	-	-	2	2.5	1.1	7577

**Notes:**

1. Pilot seat in FKM
2. With captured exhaust
3. With manual override



### 3 & 5 WAY PNEUMATIC DISTRIBUTORS



For this page	Port size	Orifice (mm)	Qn (l/min)	MOPD (bar)	Fluid Temp (°C)	Amb Temp (°C)
From	3/8"-1/4"	8	1400	10	-25	-25
To	3/8"-1/4"	8	1400	10	80	50

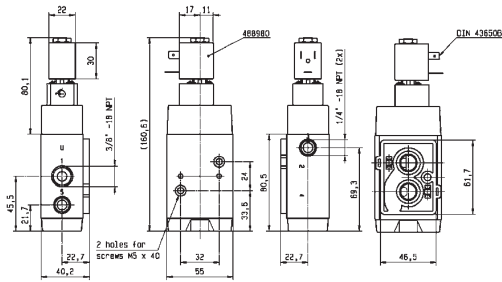

Drawing 7577

**3 & 5 WAY  
PNEUMATIC  
DISTRIBUTORS**

# 5/2

316L STAINLESS STEEL 3 & 5 WAY VALVES  
FOR ACTUATOR CONTROL (PIPE MOUNTING AND NAMUR)  
PILOT OPERATED

316L STAINLESS ST.  
NAMUR

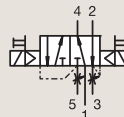

**DUAL SOLENOIDS**

Port size	Orifice Ø 1 mm	Flow factor Qn l/min	Operating Pressure Differential			Fluid Temp.		Seat Seal	Parker LUCIFER® Valves			ATEX Zone	Protection Mode	Power		Coil Group	Dwg. No.
			Min	Max (MOPD)		Min	Max		Valve Ref.	Housing Ref.	Coil Ref.			AC W	DC W		
			bar	AC bar	DC bar	°C	°C										
3/8"- 1/4"NPT	8	1400	2	10	10	-25	80	NBR	U347N3250 <sub>1</sub>	4270	481000	-	-	8	8	2.1	7557
	8	1400	2	10	10	-25	80	NBR	U347N3250 <sub>1</sub>	2995	481865	-	-	8	9	2.1	7557

**Notes:**

1. Pilot seat in FKM



### 3 & 5 WAY PNEUMATIC DISTRIBUTORS



For this page	Port size	Orifice (mm)	Qn (l/min)	MOPD (bar)	Fluid Temp (°C)	Amb Temp (°C)
From	3/8"-1/4"	8	1400	10	-25	-25
To	3/8"-1/4"	8	1400	10	80	50

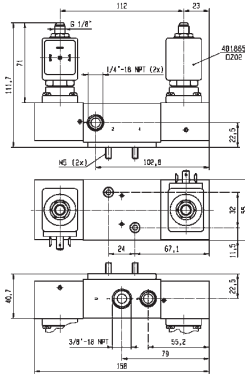

Drawing 7557

### 3 & 5 WAY PNEUMATIC DISTRIBUTORS

# 3/2

## 316L STAINLESS STEEL 3 & 5 WAY VALVES FOR ACTUATOR CONTROL (PIPE MOUNTING AND NAMUR) MANUAL RESET



Process

### 316L STAINLESS ST. PIPE MOUNTING

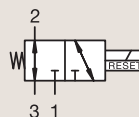

### UNIVERSAL

Port size	Orifice Ø 1 mm	Flow factor Qn l/min	Operating Pressure Differential			Fluid Temp.		Seat Seal	Parker LUCIFER® Valves			ATEX Zone	Protection Mode	Power		Coil Group	Dwg. No.
			Min bar	Max (MOPD) AC bar	DC bar	Min °C	Max °C		Valve Ref.	Housing Ref.	Coil Ref.			AC W	DC W		
1/4" NPTF	6	680	0	10	10	-25	65	NBR	U033X5152 <sub>12</sub>	-	492310	1-21	Ex eb mb II T3 to T6	6	6	10.1/10.2	7029
	6	680	0	-	10	-25	65	NBR	U033X5156 <sub>2</sub>	-	482870.01	0-20	Ex ia IIC T6	-	0.3 to 3	10.1/10.2/12.0	7771
	6	680	0	10	10	-25	65	NBR	U033X5156 <sub>2</sub>	-	492310	1-21	Ex eb mb II T3 to T6	6	6	10.1/10.2/12.0	7771
	6	680	0	-	10	-25	65	NBR	U033X5156 <sub>2</sub>	-	492335	0-20	NEMA 4-4X	-	0.3 to 3	10.1/10.2/12.0	7771
	6	680	0	10	10	-25	65	NBR	U033X5156 <sub>2</sub>	-	496700	1-21	Ex db mb IIC T4 to T6	6	6	10.1/10.2/12.0	7771
	6	680	0	10	10	-25	75	NBR	U033X51561D <sub>2</sub>	-	483270.02	1-21	Ex db IIC T4 to T6	8	8	11.0	7030

#### Notes:

- DC voltage only (or coil with rectifier). Minimum drop off voltage is 15% of nominal voltage (former DIN 19251)
- Valve delivered with an individual material traceability certificate (3.1 following EN10204)



### 3 & 5 WAY PNEUMATIC DISTRIBUTORS



For this page	Port size	Orifice (mm)	Qn (l/min)	MOPD (bar)	Fluid Temp (°C)	Amb Temp (°C)
From	1/4"	6	680	10	-25	-25
To	1/4"	6	680	10	75	65

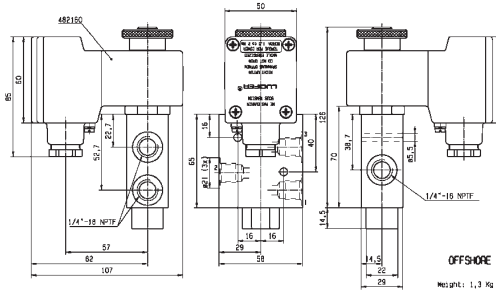

Drawing 7029

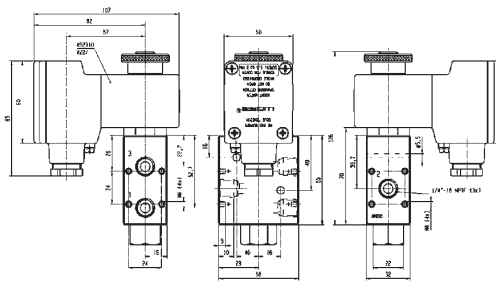

Drawing 7771

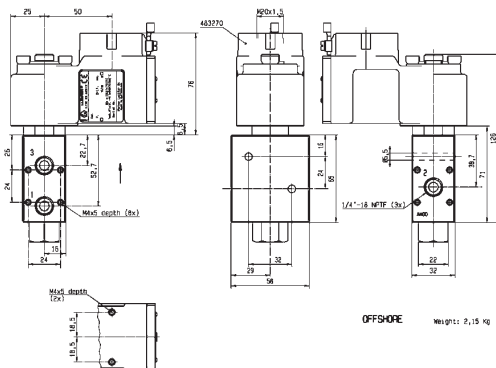

Drawing 7030



**3 & 5 WAY  
PNEUMATIC  
DISTRIBUTORS**

# 3/2

## 316L STAINLESS STEEL 3 & 5 WAY VALVES FOR ACTUATOR CONTROL (PIPE MOUNTING AND NAMUR) MANUAL RESET

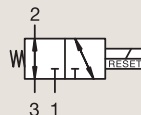
**316L STAINLESS ST.  
PIPE MOUNTING**

**UNIVERSAL**

Port size	Orifice Ø	Flow factor	Operating Pressure Differential			Fluid Temp.		Seat Seal	Parker LUCIFER® Valves			ATEX Zone	Protection Mode	Power		Coil Group	Dwg. No.
			Min	Max (MOPD)	DC bar	Min	Max		Valve Ref.	Housing Ref.	Coil Ref.			AC W	DC W		
1/4" NPTF	6	560	0	10	10	-25	65	NBR	U033X5195 <sub>2</sub>	-	492310	1-21	Ex eb mb II T3 to T6	6	6	10.1/10.2/12.0	3594
	6	560	0	10	10	-25	65	NBR	U033X5195 <sub>2</sub>	-	496700	1-21	Ex db mb IIC T4 to T6	6	6	10.1/10.2/12.0	3594
	6	680	0	10	10	-25	65	NBR	U033X7156 <sub>1</sub>	-	492310	1-21	Ex eb mb II T3 to T6	6	6	10.1/10.2	8168
	6	680	0	10	10	-25	65	NBR	U033X7156	-	496560	1-21	Ex db mb IIC T4	8	8	10.1/10.2	8168
	6	680	0	10	10	-25	65	NBR	U033X7156	-	496700	1-21	Ex db mb IIC T4 to T6	6	6	10.1/10.2	8168
	6	680	0	10	10	-25	65	NBR	U033X7156	-	496895	-	-	8	8	10.1/10.2	8168

**Notes:**

1. DC voltage only (or coil with rectifier). Minimum drop off voltage is 15% of nominal voltage (former DIN 19251)
2. Valve delivered with an individual material traceability certificate (3.1 following EN10204)





### 3 & 5 WAY PNEUMATIC DISTRIBUTORS

# 3/2

## 316L STAINLESS STEEL 3 & 5 WAY VALVES FOR ACTUATOR CONTROL (PIPE MOUNTING AND NAMUR) MANUAL RESET

### 316L STAINLESS ST. PIPE MOUNTING

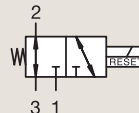

### UNIVERSAL

Port size	Orifice Ø	Flow factor	Operating Pressure Differential			Fluid Temp.		Seat Seal	Parker LUCIFER® Valves			ATEX Zone	Protection Mode	Power		Coil Group	Dwg. No.
			Min	Max (MOPD)	DC bar	Min	Max		Valve Ref.	Housing Ref.	Coil Ref.			AC W	DC W		
			Qn l/min	AC bar	DC bar	°C	°C										
3/8" NPTF	6	680	0	-	10	-25	65	NBR	U033X5256 <sub>1</sub>	-	482870.01	0-20	Ex ia IIC T6	-	0.3 to 3	10.1/10.2/12.0	7671
	6	680	0	10	10	-25	65	NBR	U033X5256 <sub>1</sub>	-	492310	1-21	Ex eb mb II T3 to T6	6	6	10.1/10.2/12.0	7671
	6	680	0	10	10	-25	65	NBR	U033X5256 <sub>1</sub>	-	496700	1-21	Ex db mb IIC T4 to T6	6	6	10.1/10.2/12.0	7671
	6	680	0	10	10	-25	65	NBR	U033X52561D <sub>1</sub>	-	483270	1-21	Ex db IIC T4 to T6	8	8	11.0	7672
	6	680	0	10	10	-25	65	NBR	U033X52561D <sub>1</sub>	-	483270.02	1-21	Ex db IIC T4 to T6	8	8	11.0	7672

#### Notes:

1. Valve delivered with an individual material traceability certificate (3.1 following EN10204)





## EPP4 Series

## ELECTROPNEUMATIC PRESSURE REGULATORS



aerospace  
climate control  
electromechanical  
filtration  
fluid & gas handling  
hydraulics  
pneumatics  
process control  
sealing & shielding

<b>Basic</b>	1/4" 1/2"
<b>Comfort</b>	1/4" 1/2"
<b>Comfort</b>	1/2" HP 1" 2"
<b>Comfort ATEX</b>	1/2" 1" 2"



## EPP4 Series

# ELECTROPNEUMATIC PRESSURE REGULATORS

## Lucifer® EPP4 Programmable Pressure Regulator

EPP4 is an electro pneumatic pressure regulator with integrated electronic system.

A pulsed width modulated solenoid valve controls the output pressure proportionally to an analog input signal.

Very high accuracy is guaranteed thanks to a high precision closed loop signal provided by a built in pressure sensor.



## Market

- Robotics
- Paper industry
- Machine tools
- Mobile
- Buildings
- Textile
- Instrumentation
- Semi conductor



## Description of Applications

- Welding
- Speed and brake control
- Sanding
- Cutting
- Humidification
- Tension regulation
- Painting
- Presses
- Polishing
- Adaptative suspension control



## Value Propositions for the Lucifer® EPP4 Range of Proportional Pressure Regulators

- All parameters fully adjustable through the PC software Calys
- Easy to use software
- Long life expectancy
- Compact and light
- Limited inventory
- Low power
- Flexible remote display positioning
- Proven expertise of Parker, a pioneer in pressure regulation technology



### *calys* Software for EPP Comfort

Calys is a unique software in house developed to configurate all the parameters of the EPP4 Comfort range. Calys is an option of the EPP4. To use CALYS, you need to order cable reference 496449 wich permits the communication between the EPP4 and a PC.

#### Calys offers many capabilities:

- It enables distributors to reduce inventory by keeping a generic EPP4 in stock and adjust it to the needs of each customer application. They can switch for example from 0-10 V to 4-20 mA, or from 0-7 bar pressure range to 0-5 bar.
- Engineers designing a pneumatic system are able to monitor precisely all the important values (electrical or pneumatical) directly on their laptop.
- After sales technicians are able to receive via email all the parameters measured by the EPP4 installed on a machine wherever its location allowing remote ma intenance operation.
- PID regulation parameters can be adjusted with Calys to match required regulator response (like slow or reactive).



To download free Calys software click on [www.parker.com/FCDE/Support](http://www.parker.com/FCDE/Support)



EPP4 Series

# ELECTROPNEUMATIC PRESSURE REGULATORS



TABLE OF CONTENT



**Introduction EPP** .....page 412

**EPP4 Basic Range** .....page 414

**EPP4 Comfort Range** .....page 418

**EPP4 Comfort HP Range** .....page 422

**EPP4 Comfort Range ATEX** .....page 428

**Accessories** .....page 434

## INTRODUCTION

### Description Operation

The EPP4 Series is a family of electrically remote-controlled pneumatic pressure regulators with closed loop integrated electronic control.

It allows regulating the outlet pressure proportionally to an electrical control signal. The EPP4 regulator comprises a traditional servo-operated pneumatic pressure regulator, where the pilot chamber is fed by one or the other of two pulse width modulated 2-way solenoid valves.

The pressure sensor measures the outlet pressure of the regulator and provides a feedback signal to the controller.

Any difference between the control signal and the feedback signal is converted to a digital signal to energise the coil of one or the other 2-way valves to correct the position of the regulator.

The control signal can be a voltage (0-10 V) or a current (4-20 mA). The inlet of the "Filling Valve" is connected directly to the main inlet P of the

regulator; when energised this valve will fill the servo-chamber for increasing the pressure at the outlet A of the regulator.

When the other "exhaust valve" is energised (reduction of pressure at the outlet A of the regulator), the pressure of the servo-chamber will be exhausted through a discharge orifice located between the cover and the body and directly fed to the atmosphere without silencer.

The exhaust of the main regulated pressure will be made through the quick exhaust R.

The use of a conventional silencer is recommended. Both solenoid valves assure the Filling or Emptying of the servo-chamber in order to increase or decrease the pressure at the outlet of the regulator.

In rest position of the valves all ports are blocked.

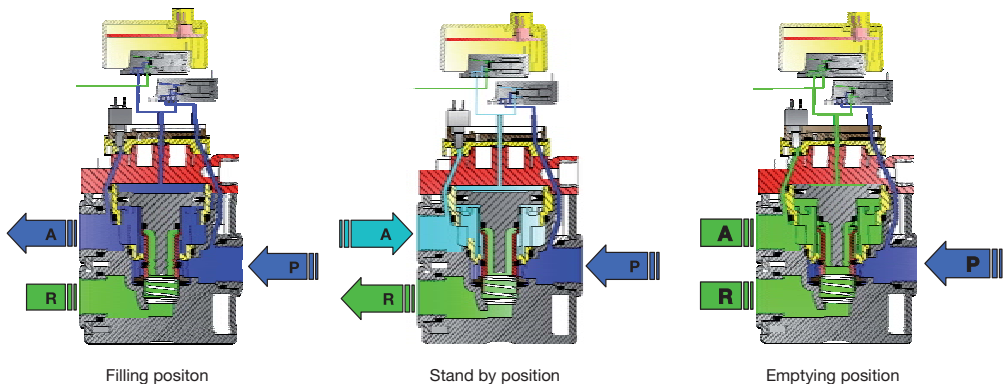

## Block Diagram

The controller receives both the control signal (set pressure) and the feedback signal from the sensor (outlet pressure).

Any difference between the two amplifier inputs results in a corresponding output which drives the appropriate 2-way pulse width modulated solenoid valve so that the pilot piston moves to correct the pressure.

The same feedback signal from the sensor is used for the output feedback in voltage and current.

The digital signal (alarm) is activated when the conditions (out of pressure or time tolerance) are met.

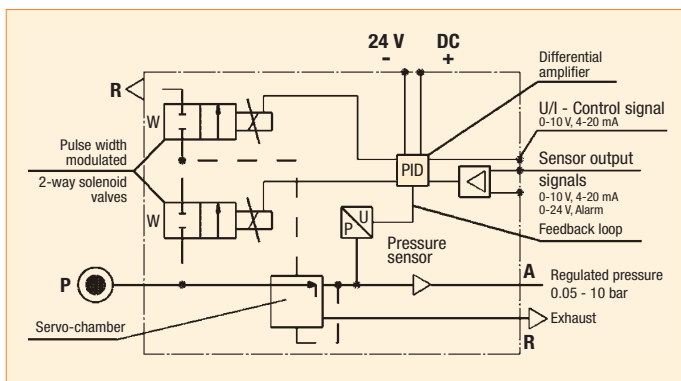

## EPP4 possible executions : Basic and Comfort

EPP4 Basic and Comfort ranges share the same reliable mechanical parts. Proportional regulation is also identical for the two different executions, giving the same characteristics for hysteresis or precision for instance.

Comfort range regulators have a second M12 connector, that can be used to connect a remote display showing the current regulated pressure, or a PC to easily set the regulation's parameters. These are the key feature options for a comfortable use.

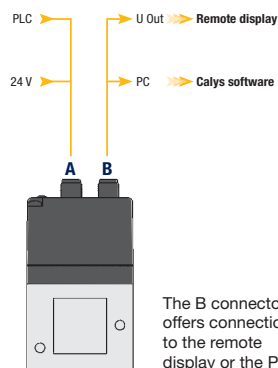

# LUCIFER® EPP4 BASIC 1/4" & 1/2"

<b>Basic</b>	1/4" 1/2"
<b>Comfort</b>	1/4" 1/2"
<b>Comfort</b>	1/2" HP 1" 2"
<b>Comfort ATEX</b>	1/2" 1" 2"

## TECHNICAL DATA

	Basic 1/4"	Basic 1/2"
<b>Fluids:</b>	Lubricated or non lubricated air and neutral gases Recommended filtration: 50 µm	
<b>Temperature range:</b>	Ambient: 0°C to +50°C Fluid: 0°C to +50°C	
<b>Inlet pressure range:</b> The inlet pressure must always be at least 1 bar above the regulated pressure.	1 to 12 bar	1 to 12 bar
<b>Outlet pressure range:</b>	0.05 to 10 bar	
<b>Hysteresis:</b>	± 50 mbar (factory set up)	
<b>Air consumption at constant control signal:</b>	0	
<b>Supply voltage:</b>	24 V DC ± 15% (Max. ripple 1 V)	
<b>Power consumption:</b>	Max. 2.8 W with 24 V DC and constant changes of the control signal < 1.5 W without change of control signal	
<b>Control signal:</b>	Analog 0 - 10 V Analog 4 - 20 mA	
<b>Max. flow:</b> Indicative response time: With a volume of 330 cm³ at the outlet of the regulator	70 m³/h	150 m³/h
<b>Filling 2 to 4 bar:</b>	50 msec	60 msec
<b>Filling 2 to 8 bar:</b>	100 msec	120 msec
<b>Emptying 4 to 2 bar:</b>	70 msec	90 msec
<b>Emptying 8 to 2 bar:</b>	130 msec	190 msec
<b>Safety position:</b>	In case of control signal failure or if it is less than 50mV, the regulated pressure drops automatically to 0 bar (atmospheric pressure). In case of voltage supply failure, the regulated pressure will be kept constant.	
<b>Electrical connection:</b>	M12 - 4 pin; 4 x 0.34 mm²	
<b>Life expectancy:</b>	> 50 Million changes of control signal steps	
<b>Mounting position:</b>	Indifferent (recommended position: upright; electronic part on top)	
<b>Resistance to vibrations:</b>	30 g in all directions	
<b>Degree of protection:</b>	IP 65	
<b>Assembly:</b>	Silicone free	
<b>Electromagnetic compatibility:</b> In accordance with:	EN 61000-6-1: 2001 EN 61000-6-2: 2001 EN 61000-6-3: 2001 EN 61000-6-4: 2001	
<b>Installation and setting instructions:</b>	See our "Notice 408038, 408014" and appendix supplied with the product.	

**Note:** Parker reserves the right to change specifications without notification.



# LUCIFER® EPP4 BASIC 1/4" & 1/2"

## FLOW CURVES

Flow Curve Basic 1/4"

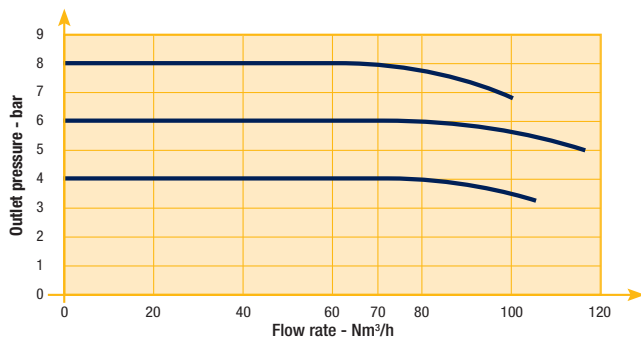

Flow Curve Basic 1/2"

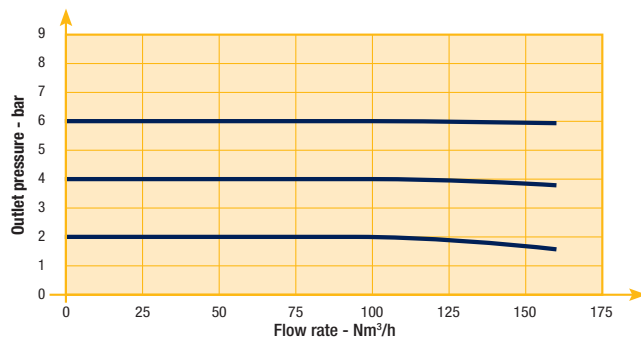

## LUCIFER® EPP4 BASIC 1/4" & 1/2"

### REFERENCES

Codes	Pipe	Pressure Range (bar)	Control Signal (see options)	Drawing Number
P4BG2001A001	G 1/4"	0 - 4 bar	4 - 20 mA	1
P4BG2001A002	G 1/4"	0 - 10 bar	0 - 10 V	1
P4BG2001A003	G 1/4"	0 - 10 bar	4 - 20 mA	1
P4BG2001A004	G 1/4"	0 - 6 bar	0 - 10 V	1
P4BG2001A005	G 1/4"	0 - 6 bar	4 - 20 mA	1
P4BG2001A006	G 1/4"	0 - 5 bar	0 - 10 V	1
P4BG2001A007	G 1/4"	0 - 5 bar	4 - 20 mA	1
P4BG2001A008	G 1/4"	0 - 7 bar	0 - 10 V	1
P4BG2001A009	G 1/4"	0 - 7 bar	4 - 20 mA	1
P4BG2003A002 *	G 1/4"	0 - 10 bar	0 - 10 V	1
P4BG2003A003 *	G 1/4"	0 - 10 bar	4 - 20 mA	1
P4BG4001A002	G 1/2"	0 - 10 bar	0 - 10 V	2
P4BG4001A003	G 1/2"	0 - 10 bar	4 - 20 mA	2
P4BG4001A004	G 1/2"	0 - 6 bar	0 - 10 V	2
P4BG4001A005	G 1/2"	0 - 6 bar	4 - 20 mA	2
P4BG4001A006	G 1/2"	0 - 5 bar	0 - 10 V	2
P4BG4001A007	G 1/2"	0 - 5 bar	4 - 20 mA	2
P4BG4001A008	G 1/2"	0 - 7 bar	0 - 10 V	2
P4BG4001A009	G 1/2"	0 - 7 bar	4 - 20 mA	2
P4BG4004A010 ***	G 1/2"	0 - 4 bar	0 - 10 V	2
P4BG4051A002 **	G 1/2"	0 - 10 bar	4 - 20 mA	2
P4BN2001A002	NPT 1/4"	0 - 10 bar	0 - 10 V	2
P4BN2001A003	NPT 1/4"	0 - 10 bar	4 - 20 mA	2
P4BN4001A002	NPT 1/2"	0 - 10 bar	0 - 10 V	2
P4BN4001A003	NPT 1/2"	0 - 10 bar	4 - 20 mA	2

\* Integrated pilot exhaust

\*\* O<sub>2</sub>

\*\*\* External pressure supply



# LUCIFER® EPP4 BASIC 1/4" & 1/2"

## DIMENSIONS DRAWINGS EPP4 BASIC 1/4"

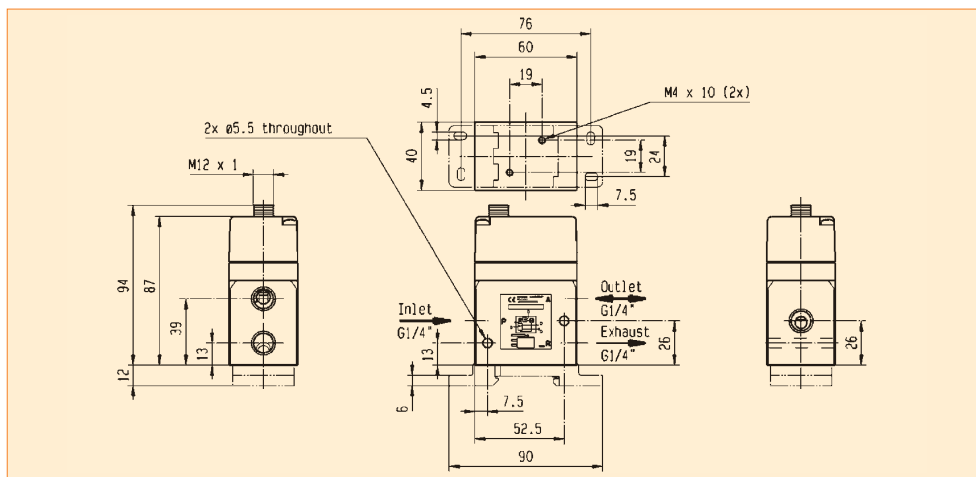

Drawing 1

## DIMENSIONS DRAWINGS EPP4 BASIC 1/2"

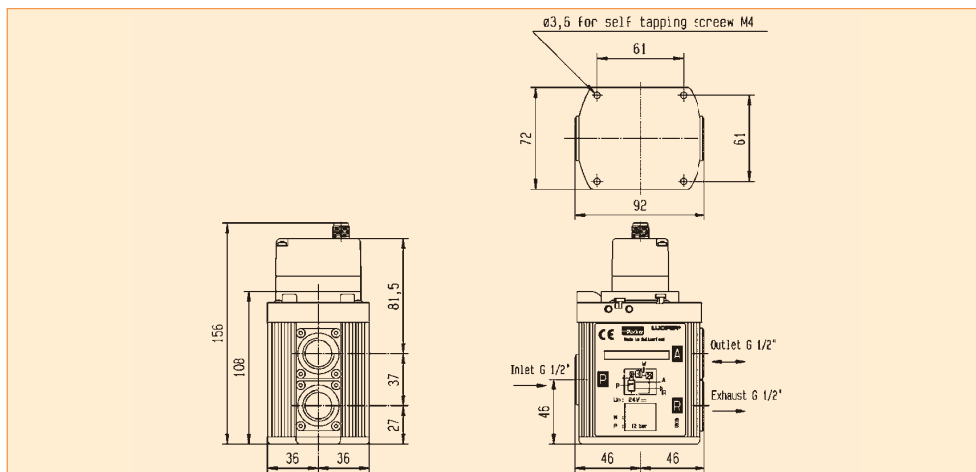

Drawing 2



# LUCIFER® EPP4 COMFORT 1/4" & 1/2"

Basic	1/4" 1/2"
Comfort	1/4" 1/2"
Comfort	1/2" HP 1" 2"
Comfort ATEX	1/2" 1" 2"

## TECHNICAL DATA

	Comfort 1/4"	Comfort 1/2"
<b>Fluids:</b>	Lubricated or non lubricated air and neutral gases - Recommended filtration: 50 µm	
<b>Temperature range:</b>	Ambient: 0°C to +50 °C Fluid: 0°C to +50 °C	
<b>Inlet pressure range:</b> The inlet pressure must always be at least 1 bar above the regulated pressure.	1 to 12 bar	1 to 12 bar
<b>Outlet pressure range:</b>	0.05 bis 10 bar	
<b>Hysteresis:</b>	± 50 mbar (factory set up)	
<b>Air consumption at constant control signal:</b>	0	
<b>Supply voltage:</b>	24 V DC ± 15 % (Max. ripple 1 V)	
<b>Power consumption:</b>	Max. 2.8 W with 24 V DC and constant changes of the control signal < 1.5 W without change of control signal	
<b>Control signal:</b>	Analog 0 - 10 V Analog 4 - 20 mA	
<b>Outlet sensor signal:</b>	Analog 0 - 10 V Standard for 0 - 10 bar; Adjustable  Analog 4 - 20 mA Standard for 0 - 10 bar; Adjustable	Digital 0/24 V for alarm features: Adjustable pressure error (+/-) Adjustable delay ON Adjustable delay OFF Adjustable logic (+/-)
<b>Max. flow:</b>	70 m³/h	150 m³/h
<b>Indicative response time:</b>	With a volume of 330 cm³ at the outlet of the regulator	
Filling 2 to 4 bar :	50 msec	60 msec
Filling 2 to 8 bar:	100 msec	120 msec
Emptying 4 to 2 bar:	70 msec	90 msec
Emptying 8 to 2 bar:	130 msec	190 msec
<b>Safety position:</b>	In case of control signal failure or if it is less than 50 mV, the regulated pressure drops automatically to 0 bar (atmospheric pressure).  In case of voltage supply failure, the regulated pressure will be kept constant.	
<b>Electrical connection:</b>	M12 - 8 pin; male connector power supply/control signal M12 - 5 pin; male connector communication	
<b>Life expectancy:</b>	> 50 Million changes of control signal steps	
<b>Mounting position:</b>	Indifferent (recommended position: upright; electronic part on top)	
<b>Resistance to vibrations:</b>	30 g in all directions	
<b>Degree of protection:</b>	IP 65	
<b>Assembly:</b>	Silicone free	
<b>Electromagnetic compatibility: In accordance with:</b>	EN 61000-6-1: 2001 EN 61000-6-2: 2001 EN 61000-6-3: 2001 + A11 2004 edition (01/07/07) EN 61000-6-4: 2001	
<b>Installation and setting instructions:</b>	See our "Notice 408128, 408134" and appendix supplied with the product.	

**Note:** Parker reserves the right to change specifications without notification.

# LUCIFER® EPP4 COMFORT 1/4" & 1/2"

## Flow Curves

Flow Curve 1/4"

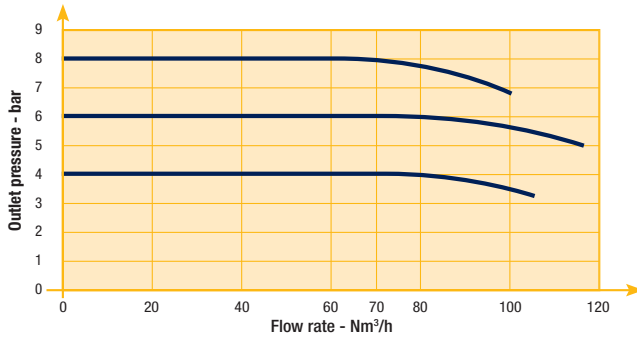

Flow Curve 1/2"

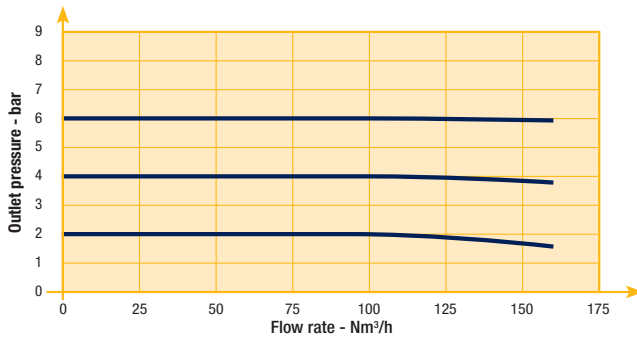

**LUCIFER® EPP4 COMFORT 1/4" & 1/2"**
**REFERENCES**

Codes	Pipe	Pressure Range (bar)	Control Signal (see options)	Display	Drawing Number
P4CG2001C001	G 1/4	0 10	0-10 V	-	3
P4CG2001C002	G 1/4	0 10	4-20 mA	-	3
P4CG2001C005	G 1/4	0 7	0-10 V	-	3
P4CG2001C006	G 1/4	0 7	4-20 mA	-	3
P4CG2002C001	G 1/4	0 10	0-10 V	included	3
P4CG2002C002	G 1/4	0 10	4-20 mA	included	3
P4CG2003C001 *	G 1/4	0 10	0-10 V	-	3
P4CG2003C002 *	G 1/4	0 10	4-20 mA	-	3
P4CG2002C007	G 1/4	0 7	0-10 V	-	3
P4CG2002C008	G 1/4	0 7	4-20 mA	-	3
P4CN2001C001	1/4 NPT	0 10	0-10 V	-	3
P4CN2001C002	1/4 NPT	0 10	4-20 mA	-	3
P4CN2002C001	1/4 NPT	0 10	0-10 V	included	3
P4CN2002C002	1/4 NPT	0 10	4-20 mA	included	3
P4CG4001C001	G 1/2	0 10	0-10 V	-	4
P4CG4001C002	G 1/2	0 10	4-20 mA	-	4
P4CG4001C005	G 1/2	0 7	0-10 V	-	4
P4CG4001C006	G 1/2	0 7	4-20 mA	-	4
P4CG4002C001	G 1/2	0 10	0-10 V	included	4
P4CG4002C002	G 1/2	0 10	4-20 mA	included	4
P4CG4002C005	G 1/2	0 7	0-10 V	-	4
P4CG4002C006	G 1/2	0 7	4-20 mA	-	4
P4CG4051C001 **	G 1/2	0 10	0-10 V	-	4
P4CG4051C002 **	G 1/2	0 10	4-20 mA	-	4
P4CN4001C001	1/2 NPT	0 10	0-10 V	-	4
P4CN4001C002	1/2 NPT	0 10	4-20 mA	-	4
P4CN4002C001	1/2 NPT	0 10	0-10 V	included	4
P4CN4002C002	1/2 NPT	0 10	4-20 mA	included	4

\* Integrated pilot exhaust

\*\* O2



# LUCIFER® EPP4 COMFORT 1/4" & 1/2"

## DIMENSIONS DRAWINGS EPP4 COMFORT RANGE 1/4"

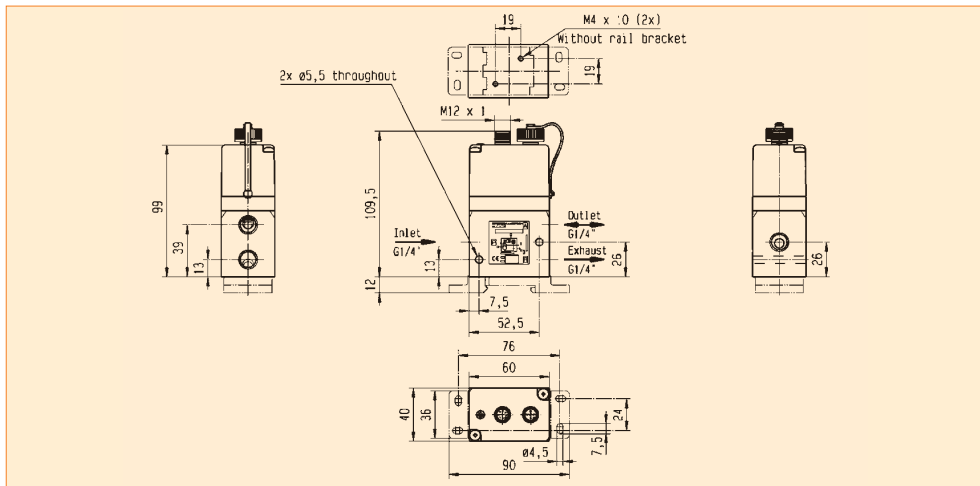

Drawing 3

## DIMENSIONS DRAWINGS EPP4 COMFORT RANGE 1/2"

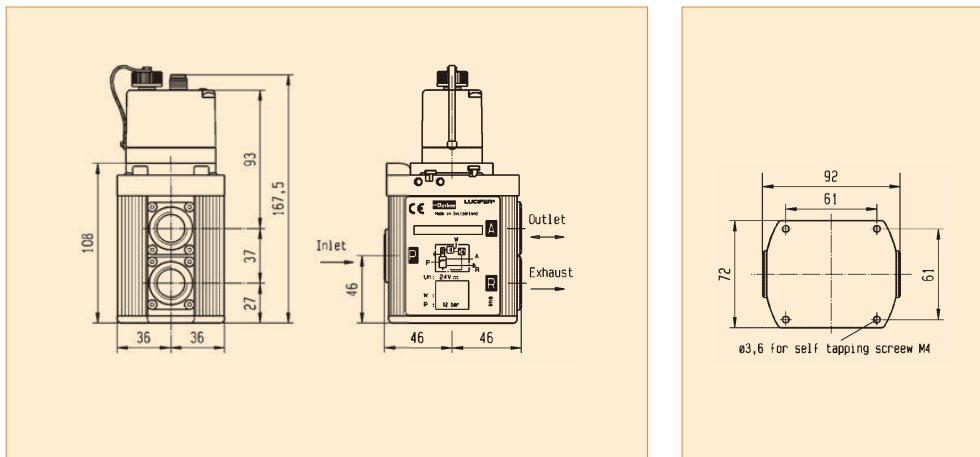

Drawing 4



**LUCIFER® EPP4 COMFORT 1/2"HP, 1" & 2"**

Basic	1/4" 1/2"
Comfort	1/4" 1/2"
<b>Comfort</b>	<b>1/2" HP 1" 2"</b>
Comfort ATEX	1/2" 1" 2"

**TECHNICAL DATA**

	Comfort 1/2" HP	Comfort 1"	Comfort 2"
<b>Fluids:</b>	Lubricated or non lubricated air and neutral gases - Recommended filtration: 50 µm		
<b>Temperature range:</b>	Ambient: 0°C to +50°C Fluid: 0°C to +50°C		
<b>Inlet pressure range:</b> The inlet pressure must always be at least 1 bar above the regulated pressure.	1 to 21 bar	1 to 21 bar	1 to 12 bar
<b>Outlet pressure range:</b>	0.05 to 20 bar	0.05 to 20 bar	0.05 to 10 bar
<b>Hysteresis:</b>	≤ 100 mbar if P inlet ≤ 10 bar ≤ 200 mbar if P inlet > 10 bar		
<b>Air consumption at constant control signal:</b>	0		
<b>Supply voltage:</b>	24V DC ± 15%		
<b>Power consumption:</b>	Max. 6 W with 24 V DC and constant changes of the control signal < 2 W without change of control signal		
<b>Control signal:</b>	Analog 0 - 10 V Analog 4 - 20 mA		
<b>Outlet sensor signal:</b>	Analog 0 - 10 V Standard for 0 - 10 bar; Adjustable	Digital 0/24 V for alarm features: Adjustable pressure error (+/-) Adjustable delay ON Adjustable delay OFF Adjustable logic (+/-)	
<b>Max. flow:</b>	150 m³/h	1 000 m³/h	2 700 m³/h
<b>Indicative response time:</b>	With a volume of 330 cm³ at the outlet of the regulator		
Filling 2 to 8 bar:	120 msec	250 msec	250 msec
Emptying 8 to 2 bar:	190 msec	400 msec	400 msec
<b>Safety position:</b>	In case of control signal failure or if it is less than 50 mV, the regulated pressure drops automatically to 0 bar atmospheric pressure (for pressure ranges from 0-10 bar, 100 mV for pressure range over 10 bar). In case of voltage supply failure, the regulated pressure will be kept constant.		
<b>Electrical connection:</b>	M12 - 8 pin; male connector power supply/control signal M12 - 5 pin; male connector communication		
<b>Life expectancy:</b>	> 20 Million changes of control signal steps		
<b>Mounting position:</b>	Indifferent (recommended position: upright; electronic part on top)		
<b>Resistance to vibrations:</b>	30 g in all directions		
<b>Degree of protection:</b>	IP 65		
<b>Assembly:</b>	Silicone free		
<b>Electromagnetic compatibility:</b> <b>In accordance with:</b>	EN 61000-6-1: 2001 EN 61000-6-2: 2001 EN 61000-6-3: 2001 + A11 2004 edition (01/07/07) EN 61000-6-4: 2001		
<b>Installation and setting instructions:</b>	See our "408 193" and appendix supplied with the product.		

**Note:** Parker reserves the right to change specifications without notification.

# LUCIFER® EPP4 COMFORT 1/2"HP, 1" & 2"

## FLOW CURVES



Flow Curve 1/2"HP

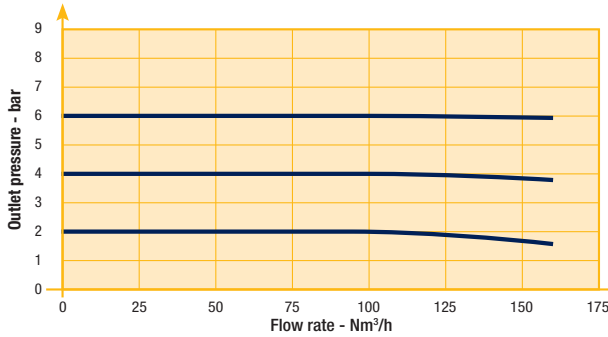

Flow Curve 1"

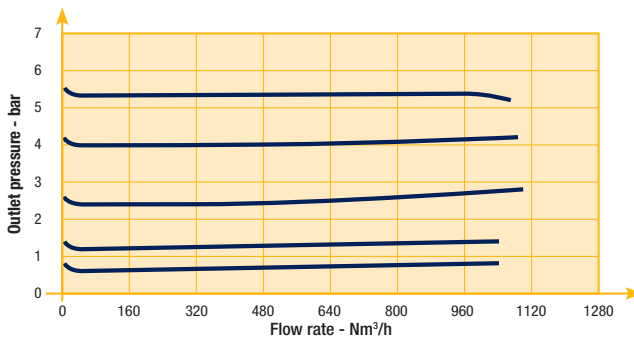

Flow Curve 2"

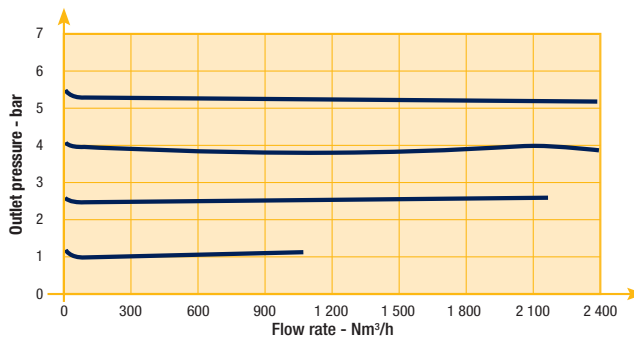

## LUCIFER® EPP4 COMFORT 1/2"HP

### REFERENCES

Codes	Pipe	Max inlet pressure (bar)	Pressure range (bar)	Control signal (see options)	Dimensional Drawing
P4CG4101D001	G1/2	15	0 12	0-10 V	5
P4CG4201D005	G1/2	21	0 16	0-10 V	6
P4CG4201D003	G1/2	21	0 20	0-10 V	6
P4CG4201D004	G1/2	21	0 20	4-20 mA	6

Other specific settings or specialties are available, please contact us.



# LUCIFER® EPP4 COMFORT 1/2"HP

## DIMENSIONS DRAWINGS

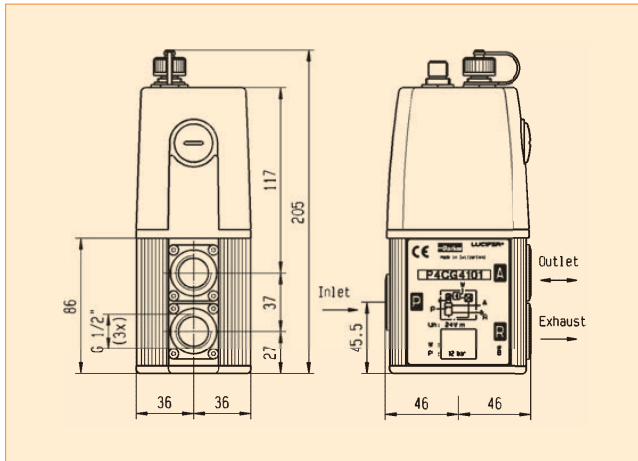

Drawing 5

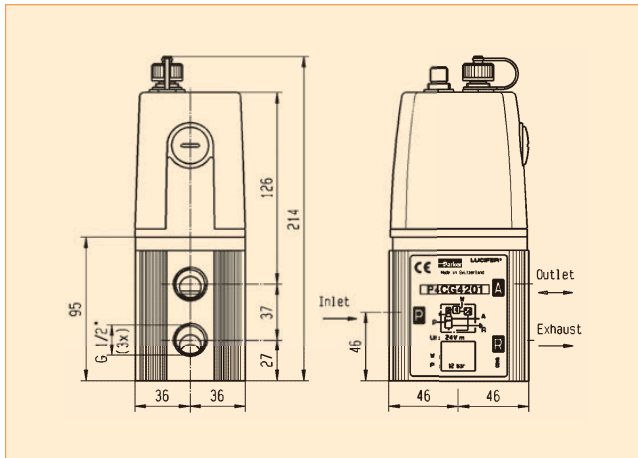

Drawing 6



## LUCIFER® EPP4 COMFORT 1" & 2"

### REFERENCES

Codes	Pipe	Max inlet pressure (bar)	Pressure range (bar)		Control signal (see options)	Dimensional Drawing
P4CG6101C009	G1	12	0	3.5	4-20 mA	7
P4CG6101C011	G1	12	0	5.0	0-10 V	7
P4CG6101C010	G1	12	0	6.0	4-20 mA	7
P4CG6101C001	G1	12	0	10	0-10 V	7
P4CG6101C002	G1	12	0	10	4-20 mA	7
P4CG6201D001	G1	21	0	12	0-10 V	7
P4CG6201D003	G1	21	0	20	0-10 V	7
P4CG9101C012	G2	12	0	4.0	4-20 mA	8
P4CG9101C010	G2	12	0	6.0	4-20 mA	8
P4CG9101C001	G2	12	0	10	0-10 V	8
P4CG9101C002	G2	12	0	10	4-20 mA	8

Other specific settings or specialties are available, please contact us.

## LUCIFER® EPP4 COMFORT 1" & 2"

### DIMENSIONS DRAWINGS EPP4 COMFORT RANGE 1"

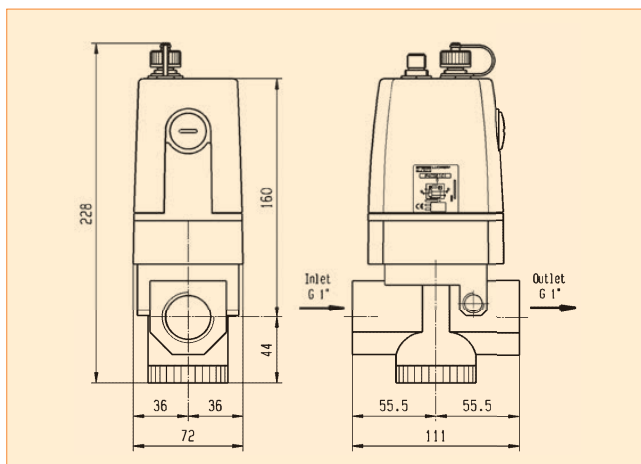

Drawing 7



### DIMENSIONS DRAWINGS EPP4 COMFORT RANGE 2"

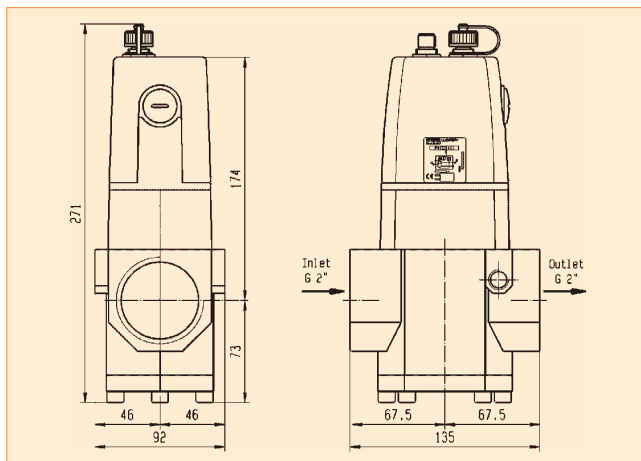

Drawing 8



**LUCIFER® EPP4 COMFORT 1/2", 1" & 2" ATEX**

Basic	1/4" 1/2"
Comfort	1/4" 1/2"
Comfort	1/2" HP 1" 2"
Comfort ATEX	1/2" 1" 2"

**TECHNICAL DATA**

	Comfort 1/2" ATEX	Comfort 1" ATEX	Comfort 2" ATEX
<b>Fluids:</b>	Lubricated or non lubricated air and neutral gases - Recommended filtration: 50 µm		
<b>Temperature range:</b>	Ambient: 0°C to +50°C Fluid: 0°C to +50°C		
<b>Inlet pressure range:</b> The inlet pressure must always be at least 1 bar above the regulated pressure.	Inlet pressure range: 1 to 12 bar		
<b>Outlet pressure range:</b>	Outlet pressure range: 0.05 to 10 bar		
<b>Hysteresis:</b>	≤ 100 mbar		
<b>Air consumption at constant control signal:</b>	0		
<b>ATEX certification:</b>	Ex II 3 G/D Ex nA IIC T4 Gc Ex tc IIB T130°C Dc		
<b>Supply voltage:</b>	24V DC ± 15 %		
<b>Power consumption:</b>	Max. 6 W with 24 V DC and constant changes of the control signal < 2 W without change of control signal		
<b>Control signal:</b>	Analog 0 - 10 V Analog 4 - 20 mA		
<b>Outlet sensor signal:</b>	Analog 0 - 10 V Standard for 0 - 10 bar; Adjustable	Digital 0/24 V for alarm features: Adjustable pressure error (+/-) Adjustable delay ON Adjustable delay OFF Adjustable logic (+/-)	
	Analog 4 - 20 mA Standard for 0 - 10 bar; Adjustable		
<b>Max. flow:</b>	150 m³/h	1 000 m³/h	2 700 m³/h
<b>Indicative response time:</b>	With a volume of 330 cm³ at the outlet of the regulator		
Filling 2 to 8 bar:	120 msec	250 msec	250 msec
Emptying 8 to 2 bar:	190 msec	400 msec	400 msec
<b>Safety position:</b>	In case of control signal failure or if it is less than 50 mV, the regulated pressure drops automatically to 0 bar atmospheric pressure (for pressure ranges from 0-10 bar, 100 mV for pressure range over 10 bar). In case of voltage supply failure, the regulated pressure will be kept constant.		
<b>Electrical connection:</b>	M12 - 8 pin; male connector power supply/control signal M12 - 5 pin; male connector communication		
<b>Life expectancy:</b>	> 20 Million changes of control signal steps		
<b>Mounting position:</b>	Indifferent (recommended position: upright; electronic part on top)		
<b>Resistance to vibrations:</b>	30 g in all directions		
<b>Degree of protection:</b>	IP 54		
<b>Assembly:</b>	Silicone free		
<b>Electromagnetic compatibility: In accordance with:</b>	EN 61000-6-1: 2001 EN 61000-6-2: 2001 EN 61000-6-3: 2001 + A11 2004 edition (01/07/07) EN 61000-6-4: 2001		
<b>Installation and setting instructions:</b>	See our "408 283" and appendix supplied with the product.		

Note: Parker reserves the right to change specifications without notification.



LUCIFER® EPP4 COMFORT 1/2", 1" & 2" ATEX



FLOW CURVES

Flow Curve 1/2"

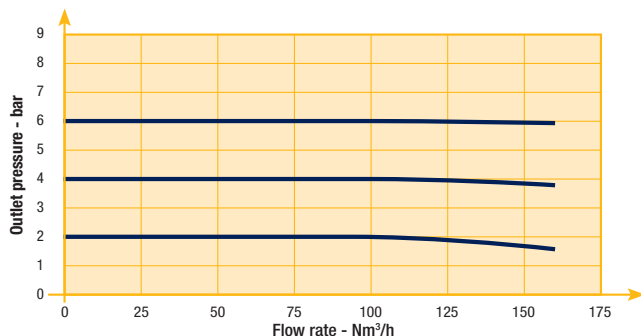

Flow Curve 1"

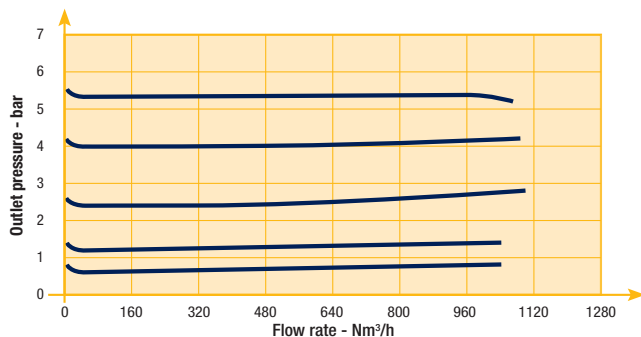

Flow Curve 2"

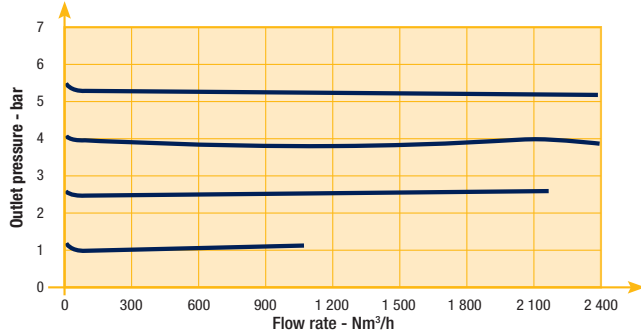

**LUCIFER® EPP4 COMFORT 1/2" ATEX**

**REFERENCES**

Codes	Pipe	Max inlet pressure (bar)	Pressure range (bar)		Control signal (see options)	Dimensional Drawing
P4CG4461C001	G1/2	12	0	10	0-10 V	9
P4CG4461C002	G1/2	12	0	10	4-20 mA	9
P4CG4465C001 **	G1/2	12	0	10	0-10 V	9
P4CG4465C002 **	G1/2	12	0	10	4-20 mA	9

\*\* O2

Other specific settings or specialties are available, please contact us.



LUCIFER® EPP4 COMFORT 1/2" ATEX 

DIMENSIONS DRAWINGS

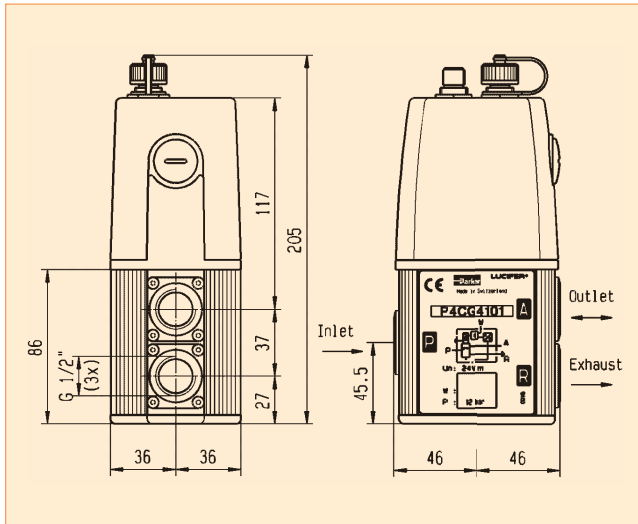

Drawing 9



**LUCIFER® EPP4 COMFORT 1" & 2" ATEX**

**REFERENCES**

Codes	Pipe	Max inlet pressure (bar)	Pressure range (bar)		Control signal (see options)	Dimensional Drawing
P4CG6161C001	G1	12	0	10	0-10 V	11
P4CG6161C002	G1	12	0	10	4-20 mA	11
P4CG9161C001	G2	12	0	10	0-10 V	12
P4CG9161C002	G2	12	0	10	4-20 mA	12

Other specific settings or specialties are available, please contact us.

LUCIFER® EPP4 COMFORT 1" & 2" ATEX



**DIMENSIONS DRAWINGS EPP4 COMFORT RANGE 1"**

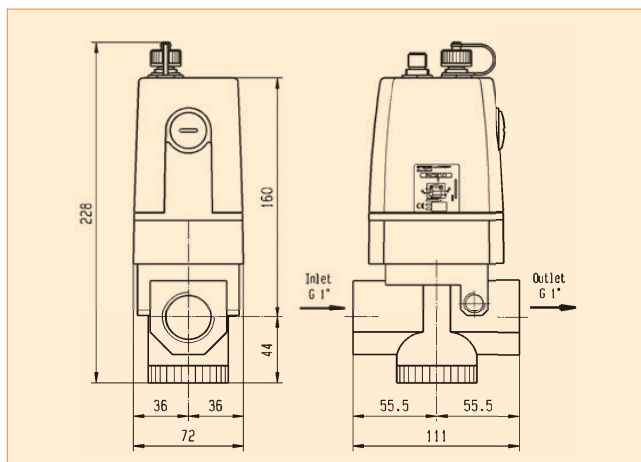

Drawing 11



**DIMENSIONS DRAWINGS EPP4 COMFORT RANGE 2"**

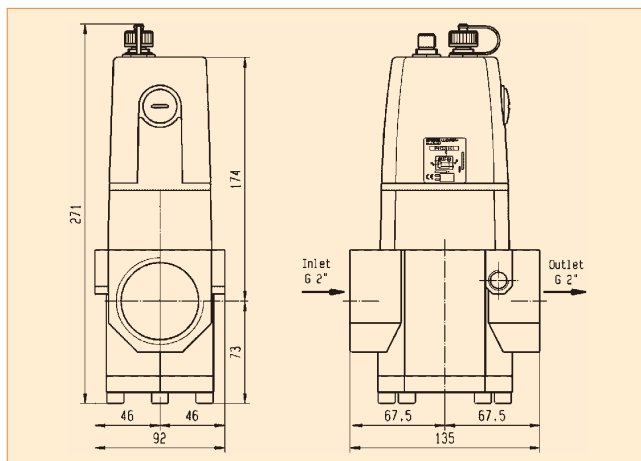

Drawing 12



## LUCIFER® EPP4 ACCESSORIES

### MOUNTING BRACKETS FOR EPP4 1/4" BASIC / COMFORT



This mounting bracket is delivered as a standard with all EPP4 1/4".

# LUCIFER® EPP4 ACCESSORIES

## MOUNTING BRACKETS FOR EPP4 1/2" BASIC / COMFORT

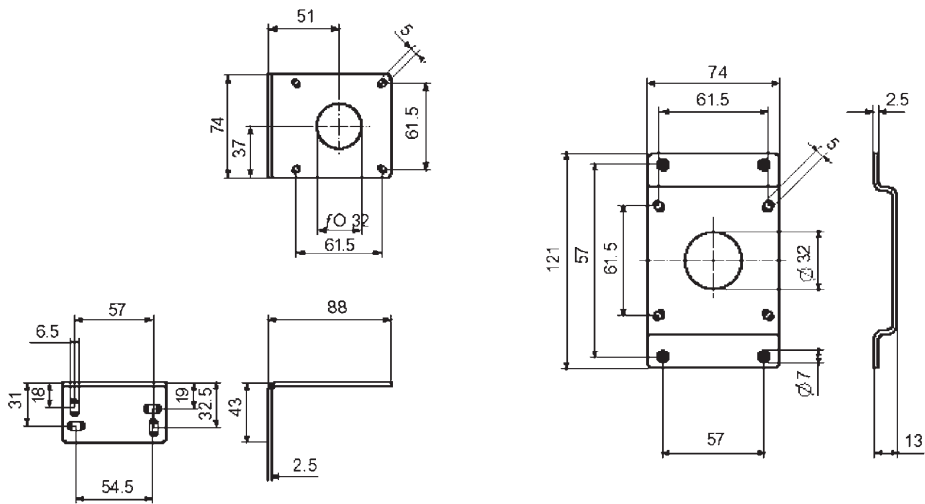

Order reference 491367



Order reference 491366



## LUCIFER® EPP4 ACCESSORIES

### POWER SUPPLY/CONTROL SIGNAL CABLE FOR BASIC AND COMFORT VERSIONS.

#### Cable for Basic EPP4

- 2 m cable with moulded straight M12-4 pole

**Order Ref. P8L-MC04A2A-M12**

#### Cable for Comfort EPP4

- 2 m cable with moulded straight M12-8 pole

**Order Reference 496796**



## LUCIFER® EPP4 COMFORT ACCESSORIES

### calys SOFTWARE

Calys is a unique software in house developed to configurate all the parameters of the EPP4 Comfort range. Calys is an option of the EPP4. A specific cable is needed for the communication between the EPP4 and a PC.



Calys offers many capabilities:

- Live monitoring (control signal, regulated pressure, supply voltage,...)
- Recording of the main parameters (control signal, regulated pressure, supply voltage,...) in an Excel file
- Free calibration for the inputs and outputs
- Adjustable alarm (positive-negative, pressure limits, delays)
- Configuration files easy to duplicate
- Complete and interactive help file
- Data in 4 different pressure units
- Menus in 4 languages (English, German, French and Italian)

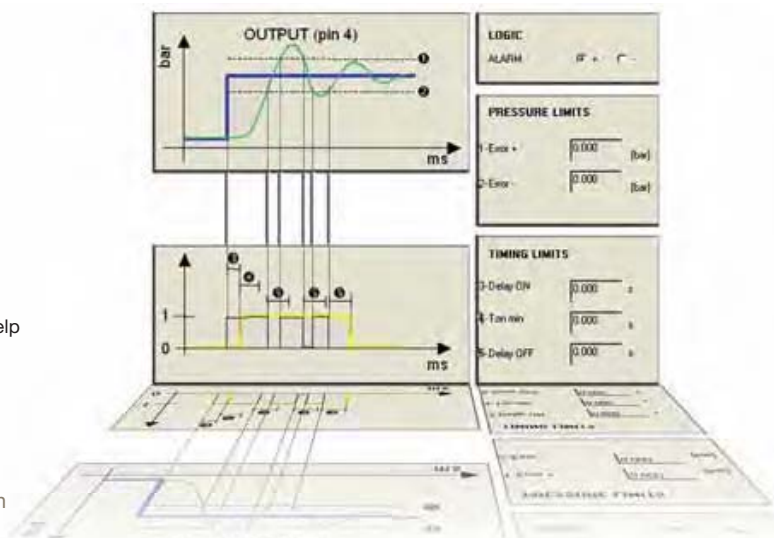

**Specific communication cable PC-EPP4 with RS232 and USB connection**

**Order Reference 496449**

This option is for safe area only.

To download free Calys software click on [www.parker.com/FCDE/Support](http://www.parker.com/FCDE/Support)



## LUCIFER® EPP4 COMFORT ACCESSORIES

### REMOTE DISPLAY

This option includes the Remote Display and 1.5 meter connecting cable. Connected to the pressure regulator, it offers flexible monitoring. This option only works with EPP4 0-10 bar.

Compact and highly readable remote LED display:

- Bar and PSI scales
- Security lock
- 1.5 m cable
- Mounting brackets

**Order the Remote Display under reference 496490**

This option is for safe area only.



### PANEL MOUNTING KIT

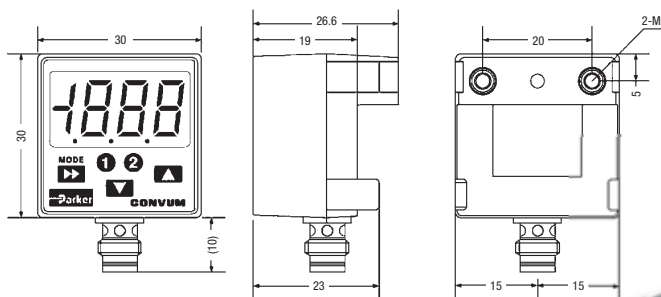

**Order the Panel Mounting Kit under reference 496601**



## COILS, HOUSINGS & ELECTRICAL PARTS

A COMPLETE RANGE OF COILS, HOUSINGS  
AND ELECTRICAL PARTS FOR SOLENOID VALVES



## DEFINITIONS

### HOUSINGS OR COIL ASSEMBLY KITS, COILS AND ELECTRICAL PARTS



#### Housing:

We define a **housing** as the combination of the fixing elements including the nameplate **1**, the cover **2** or the subplate **6** and the envelope itself **4** or **5** which protects the coil and its electrical components. The housings may be made of metal or plastic material.

#### Coil assembly kit:

The coil assembly kit **7** or **9** is the set comprising a plate, washer and nut. Sometimes coil assembly kits consist only of a nut or a special fixing device.

#### Coil:

This consists of the winding and its plastic moulding. There are three different types of coils distinguished by their shape and dimensions: 40 mm **3**, 32 mm **8** and 22 mm **10**.

#### Electric part:

The electric part is the set comprising the housing, the assembly kit and the coil.

#### Attention:

Any Parker FCDE coil or electrical part may be energised only when mounted on a valve. Otherwise there is a risk of damaging the product and its surroundings (overheating, explosion, fire, etc.).

## TABLE OF CONTENT

### INTRODUCTION

Index for Explosion Proof Electrical Parts.....	442
List of Coil Groups.....	443

### COILS

Coils for DIN plug connection.....	446
Coils with flying leads.....	469
Coils with screw terminal.....	474
Coils with ISO-DIN connector.....	481

### EXPLOSION PROOF ELECTRICAL PARTS

Level of protection "nAc nCc".....	484
Level of protection "db".....	492
Level of protection "mb".....	494
Level of protection "db mb".....	499
Level of protection "eb".....	504
Level of protection "eb mb".....	505
Level of protection "ia".....	508

<b>HOUSINGS</b> .....	518
-----------------------	-----

<b>COIL ACCESSORIES</b> .....	522
-------------------------------	-----

<b>EXPLOSIVE ENVIRONMENTS</b> .....	524
-------------------------------------	-----

### COIL APPENDICES

Guidance chart for IS-Barriers.....	534
-------------------------------------	-----

## INDEX FOR EXPLOSION PROOF ELECTRICAL PARTS

Coil Reference	Coil Group	Designation	Power DC Pn (W)	Power AC Pn (W)	Ambient Temperature	UL	Degree of Protection	ATEX or NEMA 4X Protection (Gas)	Page
496637	1.2	Explosion proof electrical part "nAc nCc", 22 mm, double frequency	3.0	3.0	-20°C to +50°C	-	IP65	II 3 D Ex to IICT 95°C	485
495880	2.0/2.2	Explosion proof electrical part "nAc nCc", 32 mm	14.0	14.0	-40°C to +50°C	-	IP65	II 3 G Ex nAc nCc IIC T3	489
496155	2.0/2.2	Explosion proof increased safety electrical part "nAc nCc", 50 mm	14.0	14.0	-40°C to +65°C	-	IP67	II 3 G Ex nAc nCc IIC T3	491
495915	4.0	Explosion proof increased safety electrical part "nAc nCc", 50 mm	13.0	11.0	-40°C to +65°C	-	IP67	II 3 G Ex nAc nCc IIC T3	490
495870	2.0/2.1	Explosion proof electrical part "nAc nCc", 32 mm	9.0	8.0	-40°C to +50°C	-	IP65	II 3 G Ex nAc nCc IIC T3/T4	486
495875	3.0	Explosion proof electrical part "nAc nCc", 32 mm	7.0	6.0	-40°C to +50°C	-	IP65	II 3 G Ex nAc nCc IIC T3/T4	488
496110	2.0/2.1	Explosion proof electrical part "nAc nCc", 32 mm	-	9.0	-40°C to +50°C	-	IP65	II 3 G Ex nAc nCc IIC T3/T4	486
495865	1.1	Explosion proof electrical part "nAc nCc", low power, 22 mm	2.5	2.0	-40°C to +50°C	-	IP65	II 3 G Ex nAc nCc IIC T5	484
496125	6.0	Explosion proof electrical part "nAc nCc", low power, 32 mm	1.6	-	-40°C to +50°C	-	IP65	II 3 G Ex nAc nCc IIC T5/T6	487
492670	2.0/2.1	Explosion proof encapsulated electrical part "mb", 32 mm	9.0	8.0	-40°C to +50°C	-	IP65	II 2 G Ex mb IIC T4	495
482605	1.1	Explosion proof encapsulated electrical part "mb", 32 mm	5.0	4.0	-40°C to +65°C	-	IP65	II 2 G Ex mb IIC T4/T5	494
482606	1.1	Explosion proof encapsulated electrical part "mb", low power, 32 mm	2.5	2.0	-40°C to +65°C	-	IP65	II 2 G Ex mb IIC T4/T5	494
492070	2.0/2.1	Explosion proof encapsulated electrical part "mb", with water proof metal housing, 50 mm	8.0	9.0	-40°C to +65°C	-	IP67	II 2 G Ex mb IIC T4/T5	496
HZ10	2.0/2.1	Explosion proof encapsulated electrical part "mb", double frequency	8.0	8.0	-40°C to +85°C	-	IP65	II 2 G - Ex mb IIC T3/T4/T5	497
HZ11	2.0/2.2	Explosion proof encapsulated electrical part "mb", double frequency	14.0	14	-40°C to +85°C	-	IP65	II 2 G - Ex mb IIC T3/T4/T5	498
483270	11.0	Flame proof electrical part "db", 50 mm	8.0	8.0	-40°C to +80°C	-	IP66	II 2 G Ex db IIC T4/T5/T6	492
497105	10.3	Flame proof electrical part "db", 50 mm	8.0	8.0	-50°C to +80°C	-	IP66	II 2 G Ex db IIC T4/T5/T6	493
493640	2.0/2.1	Flame proof encapsulated electrical part "db mb", double frequency	8.0	8.0	-40°C to +75°C	-	IP65	II 2 G Ex db mb IIC T4/T5	503
495905	2.0/2.1	Flame proof encapsulated electrical part "db mb", 37 mm	8.0	8.0	-40°C to +65°C	-	IP67	II 2 G Ex db mb IIC T4	500
496560	10.1	Flame proof encapsulated electrical part "db mb", 37 mm	8.0	8.0	-40°C to +65°C	-	IP67	II 2 G Ex db mb IIC T4	501
496800	10.1	Flame proof encapsulated electrical part "db mb", 37 mm	8.0	8.0	-40°C to +65°C	-	IP67	II 2 G Ex db mb IIC T4	502
495900	6.0	Flame proof encapsulated electrical part "db mb", low power, 37 mm	2.0	2.5	-40°C to +65°C	-	IP67	II 2 G Ex db mb IIC T4/T5/T6	499
496555	10.2	Flame proof encapsulated electrical part "db mb", 37 mm	6.0	6.0	-40°C to +65°C	-	IP67	II 2 G Ex db mb IIC T4/T5/T6	501
496700	10.2	Flame proof encapsulated electrical part "db mb", 37 mm	6.0	6.0	-40°C to +65°C	-	IP67	II 2 G Ex db mb IIC T4/T5/T6	502
494040	2.0/2.1	Explosion proof increased safety electrical part "eb", 50 mm	8.0	8.0	-40°C to +90°C	-	IP67	II 2 G Ex eb IIC T3/T4	504
483371	2.0/2.1	Explosion proof increased safety electrical part "eb", 50 mm	8.0	8.0	-40°C to +65°C	-	IP67	II 2 G Ex eb IIC T4	504
492190	2.0/2.1	Explosion proof increased safety and encapsulated elect. part "eb", 50 mm	9.0	11.0	-40°C to +75°C	-	IP66	II 2 G Ex eb mb IIC T3/T4	507
492310	10.1	Explosion proof increased safety and encapsulated electrical part "eb", 50 mm	6.0	6.0	-40°C to +75°C	-	IP66	II 2 G Ex eb mb IIC T4/T5	505
492210	9.0	Explosion proof increased safety and encapsulated electrical part "eb", "Booster", 50 mm	1.0 to 1.8	-	-40°C to +75°C	-	IP66	II 2 G Ex eb mb IIC T5/T6	506
495910	8.0	Explosion proof intrinsically safe electrical part "ia", "booster", 37 mm	0.3 to 1.2	-	-40°C to +80°C	-	IP67	II 1 G Ex ia IIC T4/T5/T6	509
496565	9.0	Explosion proof intrinsically safe electrical part "ia", "Booster", 37 mm	0.77 to 2.58	-	-40°C to +80°C	-	IP67	II 1 G Ex ia IIC T4/T5/T6	510
483580.01	7.0	Explosion proof intrinsically safe electrical part "ia", 32 mm	3.0	-	-40°C to +55°C	-	IP65	II 1 G Ex ia IIC T6	508
488650.01	7.0	Explosion proof intrinsically safe electrical part "ia", 50 mm	0.3 to 3.0	-	-40°C to +65°C	-	IP66	II 1 G Ex ia IIC T6	513
488660.01	7.0	Explosion proof intrinsically safe electrical part "ia", 50 mm	3.0	-	-40°C to +65°C	-	IP67	II 1 G Ex ia IIC T6	514
488670.01	7.0	Explosion proof intrinsically safe electrical part "ia", 50 mm	0.3 to 3	-	-40°C to +65°C	-	IP65	II 1 G Ex ia IIC T6	515
492965.01	9.0	Explosion proof intrinsically safe electrical part "ia", "Booster", 50 mm	0.3 to 2.3	-	-40°C to +65°C	-	IP66	II 1 G Ex ia IIC T6	511
482870.01	12.0	Explosion proof intrinsically safe electrical part "ia", 50 mm	3.0	-	-40°C to +65°C	-	IP66	II 1 G Ex ia IIC T6	512
490885	7.0	Explosion proof intrinsically safe electrical part, "NEMA", 50 mm	3.0	-	-40°C to +60°C	-	NEMA 4 - 4X	Cl. I, Div.I, Gr. A, B, C, D	513
490890	7.0	Explosion proof intrinsically safe electrical part, "NEMA", 50 mm	3.0	-	-40°C to +60°C	-	NEMA 4 - 4X	Cl. I, Div.I, Gr. A, B, C, D	514
492335	12.0	Explosion proof intrinsically safe electrical part, "NEMA", 50 mm	3.0	-	-40°C to +60°C	-	NEMA 4 - 4X	Cl. I, Div.I, Gr. A, B, C, D	512

## LIST OF COIL GROUPS

Parker coils and electrical parts are classified by groups determining their compatibility with Parker solenoid valves.

Group	For application with
1.1	Standard valves or on 2000 Series with standard pilot
1.2	Standard valves or on 2000 Series for high flow
1.3	Standard valves or on 2000 Series of W coil
2.0	Standard valves or on 7000 Series with standard pilot
2.1	Standard valves or on 7000 Series, for coils 8 - 9 W
2.2	Standard valves or on 7000 Series, for coils 14 W
3.0	Standard valves or on 7000 Series with reduced power
4.0	Standard valves or on 7000 Series, for bistable (Impulse) coils or electrical parts
6.0	Special valves "97" or on 7000 Series, for Intrinsically safe coils or electrical parts
7.0	Special valves "90", for coils and intrinsically safe electrical parts
8.0	Special valves "97" or on 7000 Series, for Intrinsically safe coils or electrical parts with booster
9.0	Special valves "xx" or on 9000 Series, for Intrinsically safe coils or electrical parts with booster
10.1	Standard valves or on 9000 Series with standard pilot
10.2	Standard valves or on 9000 Series "db mb"
10.3	Special valves or on 8000 Series "d"
11.0	Standard valves or on 9000 Series "1D"
12.0	Standard valves or on 9000 Series with manual reset
13.0	Special valves or on 7000 Series for Transportation
14.1	Special valves or on 7000 Series for Oil Burners
14.2	Special valves or on 7000 Series for Oil Burners
14.3	Special valves or on 7000 Series for Oil Burners
20.1	Standard valves or on 7000 Series for Z-Y coil
20.2	Standard valves or on 7000 Series for Z-Y "High Power" coil
21.0	Standard valves or on 7000 Series for J-B coil
22.0	Standard valves for KP-KT-KH coil
23.0	Standard valves for XP-XT coil for Oil Burners
24.0	Standard valves for Liquipure coils for Beverage Dispensing

COILS



## TABLE OF CONTENT

### INTRODUCTION

Index for Explosion Proof Electrical Parts.....	442
List of Coil Groups .....	443

### COILS

Coils for DIN plug connection.....	446
Coils with flying leads.....	469
Coils with screw terminal.....	474
Coils with ISO-DIN connector.....	481

### EXPLOSION PROOF ELECTRICAL PARTS

Level of protection "nAc nCc" .....	484
Level of protection "db" .....	492
Level of protection "mb" .....	494
Level of protection "db mb" .....	499
Level of protection "eb" .....	504
Level of protection "eb mb" .....	505
Level of protection "ia" .....	508

<b>HOUSINGS</b> .....	518
-----------------------	-----

<b>COIL ACCESSORIES</b> .....	522
-------------------------------	-----

<b>EXPLOSIVE ENVIRONMENTS</b> .....	524
-------------------------------------	-----

### COIL APPENDICES

Guidance chart for IS-Barriers.....	534
-------------------------------------	-----



## COILS

### COIL GROUP

# 2.0/2.1

## COILS FOR DIN PLUG CONNECTION



### COILS 32 mm

These coils can be mounted with every Parker solenoid valves corresponding to the specified Coil Group. See column "Coil Group" within valve pages.

This is an encapsulated assembly comprising a coil, integral magnetic iron path and snap-on plug connection.

The synthetic material encapsulation provides an effective compact housing, offering full protection against dust, oil, water, etc.

Ease of mounting in confined space - offers shock and corrosion protection - simplifies conversion of existing equipment to other requirements, etc.

Coils conform to the IEC/CENELEC safety standards and complies with European low-voltage directive.



Specification		Standard			Double frequency		
Ref. (without DIN plug)		481865			483510		
Ref. (with DIN plug)		482725			482635		
Coil Group		2.0 / 2.1					
Degree of protection		IP65 according to IEC / EN 60529 standards (with DIN plug).					
Class of insulation		F 155°C					
Electrical connection		The coil is connected with a 2 P + E plug according to EN 175301-803 type A					
Ambient temperature		-40°C to +50°C The application is limited also by the temperature range of the valve.					
Elect. Power	DC	Pn (hot)	9 W		-		
		P (cold) 20°C	12 W		-		
	AC	Pn (holding)	8 W		9 W		
		Attraction cold	26 VA (9 W)		32 VA (10 W)		
Weight		130 g (without plug)					
Voltages "Un"		VAC/Hz	Code	VDC	Code	VAC/Hz	Code
-10% to +10% of the Un		24/50	A2	24	C2	24/50, 24/60	P0
		48/50	A4	48	C4	48/50, 48/60	S4
		110/50	A5	110	C5	110-115/50, 120/60	S5
		220-230/50	3D			220-240/50, 240/60	S6

**To Order a Coil choose** Coil Ref + Voltage Code, example: 481865 for 24 VDC = **481865C2**

More voltage possibilities can be found in the table of voltage codes at the end of the coil section.

These coils must be used with suitable housings, see example below:

The coil assembly kit **Ref. 2995** corresponds to the "housing" of Lucifer® valve numbering system (Valve - housing - coil/voltage).

It is composed of a nameplate giving details of the valve type, a round washer and a nut to ensure the fixing between 32 mm coil and the valve.

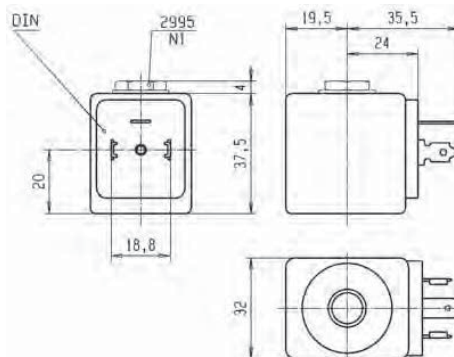

**COIL GROUP**  
**2.0/2.1**  
**2.2**

## COILS FOR DIN PLUG CONNECTION



### HIGH TEMPERATURE COILS 32 mm

These coils can be mounted with every Parker solenoid valves corresponding to the specified Coil Group.  
See column "Coil Group" within valve pages.

This is an encapsulated assembly comprising a coil, integral magnetic iron path and snap-on plug connection.

The synthetic material encapsulation provides an effective compact housing, offering full protection against dust, oil, water, etc. Ease of mounting in confined space - offers shock and corrosion protection - simplifies conversion of existing equipment to other requirements, etc.

Coils conform to the IEC/CENELEC safety standards and complies with European low-voltage directive.



Specification		High temperature				High temp. + high power				
Ref. (without DIN plug)		492453				492425				
Ref. (with DIN plug)		492726				492727				
Coil Group		2.0 / 2.1				2.0 / 2.2				
Degree of protection		IP65 according to IEC / EN 60529 standards (with DIN plug).								
Class of insulation		H 180°C								
Electrical connection		The coil is connected with a 2 P + E plug according to EN 175301-803 type A								
Ambient temperature		-40°C to +50°C The application is limited also by the temperature range of the valve.								
Elect. Power	DC	Pn (hot)	9 W				14 W			
		P (cold) 20°C	12 W				21 W			
	AC	Pn (holding)	8 W				14 W			
		Attraction cold	26 VA (9 W)				55 VA (18 W)			
Weight		130 g (without plug)								
Voltages "Un"		VAC/Hz	Code	VDC	Code	VAC/Hz	Code	VDC	Code	
-10% to +10% of the Un		24/50	A2	12	C1	24/50	A2	24	C2	
		48/50	A4	24	C2	110/50	A5			
		110/50	A5	48	C4	230/50	F4			
		220/50-230/50	3D	110	C5					

**To Order a Coil choose** Coil Ref + Voltage Code, example: 492453 for 24 VDC= **492453C2**

More voltage possibilities can be found in the table of voltage codes at the end of the coil section.

These coils must be used with suitable housings, see example below:

The coil assembly kit **Ref. 2995** corresponds to the "housing" of Lucifer® valve numbering system (Valve - housing - coil/voltage).

It is composed of a nameplate giving details of the valve type, a round washer and a nut to ensure the fixing between 32 mm coil and the valve.

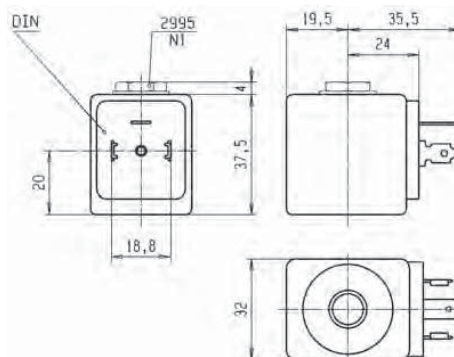

## COILS

### COIL GROUP

# 3.0

## COILS FOR DIN PLUG CONNECTION



### REDUCED POWER COIL 32 mm

These coils can be mounted with every Parker solenoid valves corresponding to the specified Coil Group.  
See column "Coil Group" within valve pages.

This is an encapsulated assembly comprising a coil, integral magnetic iron path and snap-on plug connection.

The synthetic material encapsulation provides an effective compact housing, offering full protection against dust, oil, water, etc.

Ease of mounting in confined space - offers shock and corrosion protection - simplifies conversion of existing equipment to other requirements, etc.

Coils conform to the IEC/CENELEC safety standards and complies with European low-voltage directive.



Specification		Reduced power			
Ref. (without DIN plug)		482730			
Ref. (with DIN plug)		482735			
Coil Group		3.0			
Degree of protection		IP65 according to IEC / EN 60529 standards (with DIN plug).			
Class of insulation		F 155°C			
Electrical connection		The coil is connected with a 2 P + E plug according to EN 175301-803 type A			
Ambient temperature		-40°C to +50°C The application is limited also by the temperature range of the valve.			
Elect. Power	DC	Pn (hot)	7 W		
		P (cold) 20°C	9 W		
	AC	Pn (holding)	6 W		
		Attraction cold	20 VA (7 W)		
Weight		130 g (without plug)			
Voltages "Un"		VAC/Hz	Code	VDC	Code
-10% to +10% of the Un		48/50	A4	24	C2
		220-230/50	3D	48	C4

**To Order a Coil choose** Coil Ref + Voltage Code, example: 482730 for 24 VDC = **482730C2**

More voltage possibilities can be found in the table of voltage codes at the end of the coil section.

These coils must be used with suitable housings, see example below:

The coil assembly kit **Ref. 2995** corresponds to the "housing" of Lucifer® valve numbering system (Valve - housing - coil/voltage).

It is composed of a nameplate giving details of the valve type, a round washer and a nut to ensure the fixing between 32 mm coil and the valve.

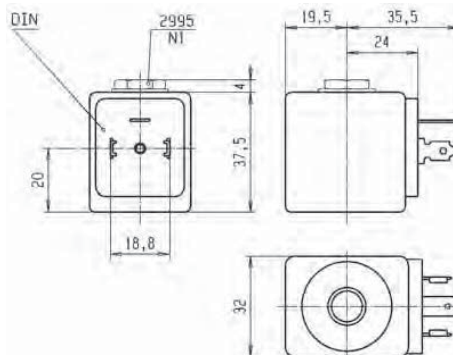

**COIL GROUP**
**6.0**
**COILS FOR  
DIN PLUG CONNECTION**

**LOW POWER COIL 32 mm**

These coils can be mounted with every Parker solenoid valves corresponding to the specified Coil Group.  
See column "Coil Group" within valve pages.

This is an encapsulated assembly comprising a coil, integral magnetic iron path and snap-on plug connection.

The synthetic material encapsulation provides an effective compact housing, offering full protection against dust, oil, water, etc.

Ease of mounting in confined space - offers shock and corrosion protection - simplifies conversion of existing equipment to other requirements, etc.

Coils conform to the IEC/CENELEC safety standards and complies with European low-voltage directive.



Specification		Miniwatt	
Reference (without DIN plug)		482740	
Reference (with DIN plug)		482745	
Coil Group		6.0	
Degree of protection		IP65 according to IEC / EN 60529 standards (with DIN plug).	
Class of insulation		F 155°C	
Electrical connection		The coil is connected with a 2 P + E plug according to EN 175301-803 type A	
Ambient temperature		-40°C to +50°C The application is limited also by the temperature range of the valve.	
Elect. Power	DC	Pn (hot)	1.6 W
		P (cold) 20°C	2.1 W
	AC	Pn (holding)	-
		Attraction cold	-
Weight		130 g (without plug)	
Voltages "Un"		VDC	Code
-10% to +10% of the Un		24	C2
		48	C4
		110	C5

**To Order a Coil choose** Coil Ref + Voltage Code, example: 482740 for 24 VDC = **482740C2**

More voltage possibilities can be found in the table of voltage codes at the end of the coil section.

These coils must be used with suitable housings, see example below:

The coil assembly kit **Ref. 2995** corresponds to the "housing" of Lucifer® valve numbering system (Valve - housing - coil/voltage).

It is composed of a nameplate giving details of the valve type, a round washer and a nut to ensure the fixing between 32 mm coil and the valve.

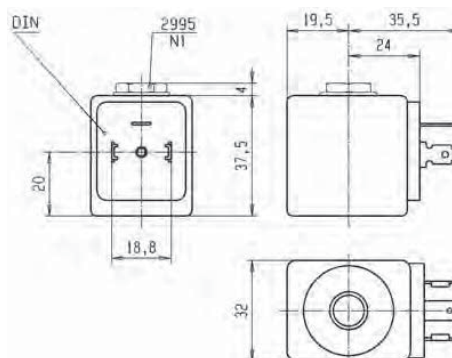

## COILS

### COIL GROUP

# 2.0/2.1

## COILS FOR DIN PLUG CONNECTION



## UL COIL 32 mm

This coil can be mounted with every Parker solenoid valves corresponding to the specified Coil Group.  
See column "Coil Group" within valve pages.

This is an encapsulated assembly comprising a coil, integral magnetic iron path and snap-on plug connection.

The synthetic material encapsulation provides an effective compact housing, offering full protection against dust, oil, water, etc.

Ease of mounting in confined space - offers shock and corrosion protection - simplifies conversion of existing equipment to other requirements, etc.

Coils conform to the IEC/CENELEC safety standards and complies with European low-voltage directive.

DIN plug connector to be ordered separately (see coil accessories section)



Specification		UL-recognized coil - UL File E200N - designation AMIF			
Reference (without DIN plug)		491514			
Coil Group		2.0 / 2.1			
Degree of protection		IP65 according to IEC / EN 60529 standards (with DIN plug).			
Class of insulation		F (155°C)			
Electrical connection		The coil is connected with a 2 P + E plug according to EN 175301-803 type A			
Ambient temperature		-40°C to 50°C The application is limited also by the temperature range of the valve.			
Elect. Power	DC	Pn (hot)	-	12 W	
		P (cold) 20°C	-	16 W	
	AC	Pn (holding)	11 W	-	
		Attraction cold	40 VA (13 W)	-	
Weight		130 g (without plug)			
Voltages "Un"		VAC/Hz	Code	VDC	Code
- 15% to +10% of the Un		110/50-120/60	P3	24	C2
		220/50-240/60	Q3		

**To Order a Coil choose** Coil Ref + Voltage Code, example: 491514 for 24 VDC = **491514C2**

More voltage possibilities can be found in the table of voltage codes at the end of the coil section.

These coils must be used with suitable housings, see example below:

The coil assembly kit

Ref. 2995 with non UL valve and Ref. 2995.03 with UL valve correspond to the "housing" of Lucifer® valve numbering system (Valve - housing - coil/voltage).

It is composed of a nameplate giving details of the valve type, a round washer and a nut to ensure the fixing between 32 mm coil and the valve.

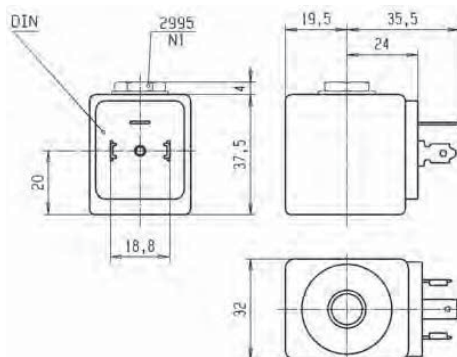

**COIL GROUP**

# 14.2

## COILS FOR DIN PLUG CONNECTION



### UL COIL 32 mm

This coil can be mounted with every Parker solenoid valves corresponding to the specified Coil Group.

See column "Coil Group" within valve pages.

This is an encapsulated assembly comprising a coil, integral magnetic iron path and snap-on plug connection.

The synthetic material encapsulation provides an effective compact housing, offering full protection against dust, oil, water, etc.

Ease of mounting in confined space - offers shock and corrosion protection - simplifies conversion of existing equipment to other requirements, etc.

Coils conform to the IEC/CENELEC safety standards and complies with European low-voltage directive.



Specification		Coil for oil burner - UL recognized	
Reference (without DIN plug)		483764	
Coil group		14.2	
Degree of protection		IP65 according to IEC / EN 60529 standards (with DIN plug).	
Class of insulation		F 155°C	
Electrical connection		With DIN 43650 A Plug	
Ambient temperature		-40°C to 50°C The application is limited also by the temperature range of the valve.	
Elect. Power	DC	Pn (hot)	-
		P (cold) 20°C	-
	AC	Pn (holding)	9 W
		Attraction cold	-
Weight		138 g	
Voltages "Un"		VAC/Hz	Code
- 15% to +10% of the Un		240/50-60	Q1
		110/50-115/60	Q9
		230/50-240/60	T1

**To Order a Coil choose** Coil Ref + Voltage Code, example: 483764 for 240/50-60 = **483764Q1**

More voltage possibilities can be found in the table of voltage codes at the end of the coil section.

These coils must be used with suitable housings, see example below:

The coil assembly kit **Ref. 2995** corresponds to the "housing" of Lucifer® valve numbering system (Valve - housing - coil - voltage).

It is composed of a nameplate giving details of the valve type, a round washer and a nut to ensure the fixing between 32 mm coil and the valve.

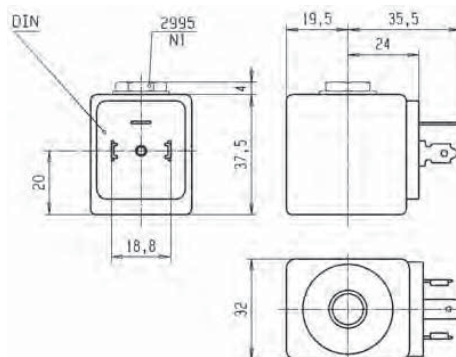

## COILS

### COIL GROUP

# 2.2

## COILS FOR DIN PLUG CONNECTION



### COIL 32 mm FOR JET VALVES

This coil can be mounted with every Parker solenoid valves corresponding to the specified Coil Group. See column "Coil Group" within valve pages.

This is an encapsulated assembly comprising a coil, integral magnetic iron path and snap-on plug connection.

The synthetic material encapsulation provides an effective compact housing, offering full protection against dust, oil, water, etc.

Ease of mounting in confined space - offers shock and corrosion protection - simplifies conversion of existing equipment to other requirements, etc.

Coils conform to the IEC/CENELEC safety standards and complies with European low-voltage directive.

DIN plug connector to be ordered separately (see coil accessories section)



Specification		32 mm coil 14 W			
Reference		483816			
Coil Group		2.2			
Degree of protection		IP65 according to IEC / EN 60529 standards (with DIN plug).			
Class of insulation		F 155°C			
Electrical connection		The coil is connected with a 2 P + E plug according to EN 175301-803 type A			
Ambient temperature		-40°C to +50°C The application is limited also by the temperature range of the valve.			
Elect. Power	DC	Pn (hot)	14 W		
		P (cold) 20°C	-		
	AC	Pn (holding)	14 W		
		Attraction cold	-		
Weight		160 g			
Voltages "Un"		VAC/Hz	Code	VDC	Code
-10% to +10% of the Un		24/50	A2	24 V	C2

**To Order a Coil choose** Coil Ref + Voltage Code, example: 483816 for 24 VDC = 483816C2

More voltage possibilities can be found in the table of voltage codes at the end of the coil section.

These coils must be used with suitable housings, see example below:

The coil assembly kit **Ref. 2995** corresponds to the "housing" of Lucifer® valve numbering system (Valve - housing - coil/voltage).

It is composed of a nameplate giving details of the valve type, a round washer and a nut to ensure the fixing between 32 mm coil and the valve.

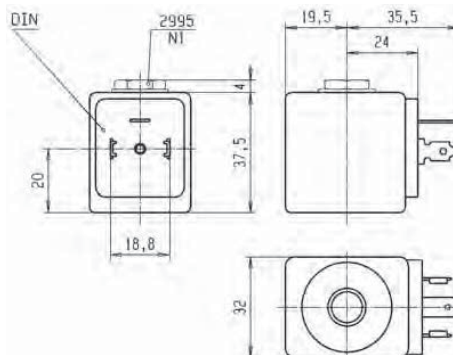

**COIL GROUP**
**1.1**
**COILS FOR  
DIN PLUG CONNECTION**

**COILS 22 mm**

These coils can be mounted with every Parker solenoid valves corresponding to the specified Coil Group.  
See column "Coil Group" within valve pages.

This coil is designed for valves equipped with a miniature tube assembly (2000 series valves). This is an encapsulated assembly comprising a coil, integral magnetic iron path and snap-on plug connection.

The synthetic material encapsulation provides an effective compact housing, offering full protection against dust, oil, water, etc.

Ease of mounting in confined space - offers shock and corrosion protection - simplifies conversion of existing equipment to other requirements, etc.

Coil conforms to the IEC/CENELEC safety standards and complies with European low-voltage directive.



Specification		Low power				High power				
Ref. (without DIN plug)		488980				481180				
Ref. (with DIN plug)		481045				481530				
Coil Group		1.1								
Degree of protection		IP65 according to IEC / EN 60529 standards (with DIN plug).								
Class of insulation		F 155°C								
Electrical connection		The coil is connected with a 2 P + E plug according to EN 175301-803 type B.								
Ambient temperature		-40°C to +50°C The application is limited also by the temperature range of the valve.								
Elect. Power	DC	Pn (hot)	2.5 W				5 W			
		P (cold) 20°C	3 W				6.5 W			
	AC	Pn (holding)	2 W				4 W			
		Attraction cold	5.7 VA (2.5 W)				8.9 VA (5 W)			
Weight		100 g with DIN Plug								
Voltages "Un"		VAC/Hz	Code	VDC	Code	VAC/Hz	Code	VDC	Code	
-10% to +10% of the Un		24/50	A2	24	C2	24/50	A2	24	C2	
		48/50	A4	48	C4	110/50-115/50	0A			
		110/50-115/50	0A			220/50-230/50	3D			
		220/50-230/50	3D							

**To Order a Coil choose** Coil Ref + Voltage Code, example: 488980 for 24 VDC = **488980C2**

More voltage possibilities can be found in the table of voltage codes at the end of the coil section.

These coils must be used with suitable housings, see example below:

The coil assembly kit **Ref. 8993** corresponds to the numbering system for Lucifer® valve housings (Valve - housing - coil/voltage).

It is composed of a nameplate with the details of the valve type, a washer and a nut to secure the 22 mm coil to the valve.

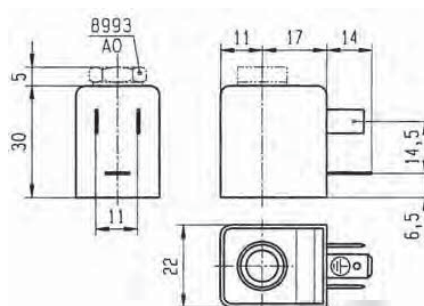

## COILS

### COIL GROUP

# 1.1

## COILS FOR DIN PLUG CONNECTION



### UL COIL 22 mm

These coils can be mounted with every Parker solenoid valves corresponding to the specified Coil Group. See column "Coil Group" within valve pages.

This coil is designed for valves equipped with a miniature tube assembly (2000 series valves). This is an encapsulated assembly comprising a coil, integral magnetic iron path and snap-on plug connection.

The synthetic material encapsulation provides an effective compact housing, offering full protection against dust, oil, water, etc.

Ease of mounting in confined space - offers shock and corrosion protection - simplifies conversion of existing equipment to other requirements, etc.

Coil conforms to the IEC/CENELEC safety standards and complies with European low-voltage directive.



Specification		Standard UL (only if used with 321K, 121M, 131M valves)			
Reference (without DIN plug)		492912			
Reference (with DIN plug)		492919			
Coil Group		1.1			
Degree of protection		IP65 according to IEC / EN 60529 standards (with DIN plug).			
Class of insulation		A 105°C for UL/CSA			
Electrical connection		The coil is connected with a 2 P + E plug according to EN 175301-803 type B.			
Ambient temperature		-40°C to +50°C The application is limited also by the temperature range of the valve.			
Elect. Power	DC	Pn (hot)	4 W		
		P (cold) 20°C	4.5 W		
	AC	Pn (holding)	3 W		
		Attraction cold	7.5 VA (4 W)		
Weight		100 g with DIN Plug			
Voltages "Un"		VAC/Hz	Code	VDC	Code
- 15% to +10% of the Un		48/50-48/60	S4	24	C2
		115/50-120/60	P8		

**To Order a Coil choose** Coil Ref + Voltage Code, example: 492912 for 24 VDC = **492912C2**

More voltage possibilities can be found in the table of voltage codes at the end of the coil section.

These coils must be used with suitable housings, see example below:

The coil assembly kit **Ref. 8993** corresponds to the "housing" of Lucifer® valve numbering system (Valve - housing - coil/voltage).

It is composed of a nameplate giving details of the valve type, a round washer and a nut to ensure the fixing between 22 mm coil and the valve.

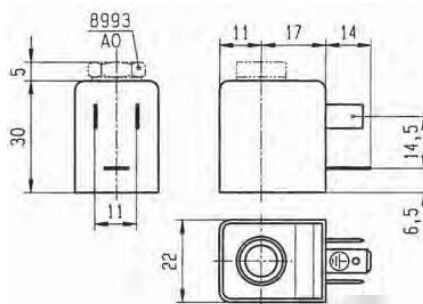

**COIL GROUP**
**1.1**
**COILS FOR  
DIN PLUG CONNECTION**

**DOUBLE FREQUENCY COIL 22 mm**

This coil can be mounted with every Parker solenoid valves corresponding to the specified Coil Group.  
See column "Coil Group" within valve pages.

This coil is designed for valves equipped with a miniature tube assembly (2000 series valves). This is an encapsulated assembly comprising a coil, integral magnetic iron path and snap-on plug connection.

The synthetic material encapsulation provides an effective compact housing, offering full protection against dust, oil, water, etc. Ease of mounting in confined space - offers shock and corrosion protection - simplifies conversion of existing equipment to other requirements, etc. Coil conforms to the IEC/CENELEC safety standards and complies with European low-voltage directive.

DIN plug connector to be ordered separately (see coil accessories section).



Specification		Double frequency	
Reference (without DIN plug)		483590	
Coil group		1.1	
Degree of protection		IP65 according to IEC / EN 60529 standards (with DIN plug).	
Class of insulation		F 155°C	
Electrical connection		The coil is connected with a 2 P + E plug according to EN 175301-803 type B.	
Ambient temperature		-40°C to +50°C The application is limited also by the temperature range of the valve.	
Elect. Power	DC	Pn (hot)	-
		P (cold) 20°C	-
	AC	Pn (holding)	3 W
		Attraction cold	7.5 VA (4 W)
Weight		100 g with DIN Plug	
Voltages "Un"		VAC/Hz	Code
-10% to +10% of the Un		24/50-60	P0
		48/50-60	S4
		110-115/50, 120/60	S5
		220-240/50, 240/60	S6

**To Order a Coil choose** Coil Ref + Voltage Code, example: 483590 for 24/50,24/60 = **483590P0**

More voltage possibilities can be found in the table of voltage codes at the end of the coil section.

These coils must be used with suitable housings, see example below:

The coil assembly kit **Ref. 8993** corresponds to the "housing" of Lucifer® valve numbering system (Valve - housing - coil/voltage).

It is composed of a nameplate giving details of the valve type, a round washer and a nut to ensure the fixing between 22 mm coil and the valve.

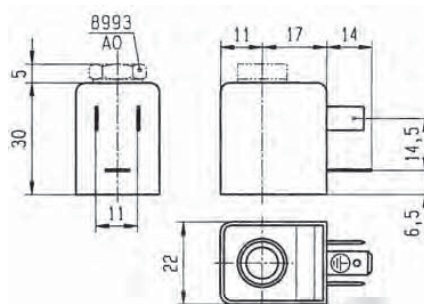

## COILS

### COIL GROUP

# 1.1

## COILS FOR DIN PLUG CONNECTION



### DOUBLE FREQUENCY COIL 22 mm

This coil can be mounted with every Parker solenoid valves corresponding to the specified Coil Group. See column "Coil Group" within valve pages.

This coil is designed for valves equipped with a miniature tube assembly (2000 series valves). This is an encapsulated assembly comprising a coil, integral magnetic iron path and snap-on plug connection.

The synthetic material encapsulation provides an effective compact housing, offering full protection against dust, oil, water, etc. Ease of mounting in confined space - offers shock and corrosion protection - simplifies conversion of existing equipment to other requirements, etc. Coil conforms to the IEC/CENELEC safety standards and complies with European low-voltage directive.

DIN plug connector to be ordered separately (see coil accessories section).



Specification		Double frequency	
Reference (without DIN Plug)		488143	
Coil group		1.1	
Degree of protection		IP65 according to IEC / EN 60529 standards (with DIN plug).	
Class of insulation		F 155°C	
Electrical connection		The coil is connected with a 2 P + E plug according to EN 175301-803 type B.	
Ambient temperature		-40°C to +50°C The application is limited also by the temperature range of the valve.	
Elect. Power	DC	Pn (hot)	-
		P (cold) 20°C	-
AC		Pn (holding)	2.5 W
		Attraction cold	-
Weight		60 g	
Voltages "Un"		VAC/Hz	Code
-10% to +10% of the Un		100/50-60	P1
		200/50-60	P6

**To Order a Coil choose** Coil Ref + Voltage Code, example: 488143 for 100/50-60 = **488143P1**

More voltage possibilities can be found in the table of voltage codes at the end of the coil section.

These coils must be used with suitable housings, see example below:

The coil assembly kit **Ref. 8993** corresponds to the "housing" of Lucifer® valve numbering system (Valve - housing - coil/voltage).

It is composed of a nameplate giving details of the valve type, a round washer and a nut to ensure the fixing between 22 mm coil and the valve.

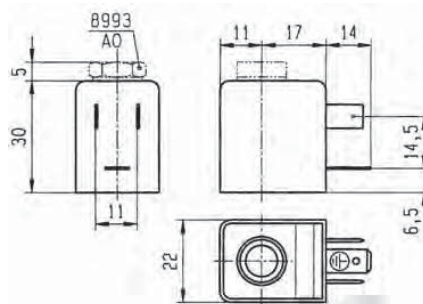

**COIL GROUP**
**1.2**
**COILS FOR  
DIN PLUG CONNECTION**

**DOUBLE FREQUENCY COIL 22 mm**

This coil can be mounted with every Parker solenoid valves corresponding to the specified Coil Group.  
See column "Coil Group" within valve pages.

This coil is designed for valves equipped with a miniature tube assembly (2000 series valves). This is an encapsulated assembly comprising a coil, integral magnetic iron path and snap-on plug connection.

The synthetic material encapsulation provides an effective compact housing, offering full protection against dust, oil, water, etc.

Ease of mounting in confined space - offers shock and corrosion protection - simplifies conversion of existing equipment to other requirements, etc.

Coil conforms to the IEC/CENELEC safety standards and complies with European low-voltage directive.

DIN plug connector to be ordered separately (see coil accessories section).



Specification		Double frequency			
Reference (without DIN Plug)		<b>496131</b>			
Coil group		<b>1.2</b>			
Degree of protection		IP65 according to IEC / EN 60529 standards (with DIN plug).			
Class of insulation		F 155°C			
Electrical connection		The coil is connected with a 2 P + E plug according to EN 175301-803 type B.			
Ambient temperature		-40°C to +50°C The application is limited also by the temperature range of the valve.			
Elect. Power	DC	Pn (hot)	3 W		
		P (cold) 20°C	-		
AC		Pn (holding)	3 W		
		Attraction cold	-		
Weight		60 g			
Voltages "Un"		VAC/Hz	Code	VDC	Code
-10% to +10% of the Un		24/50-60	P0	24 V	C2
		110/50-60	P2	48 V	C4
		230/50-60	P9	110 V	C5
		48/50-60	S4		

**To Order a Coil choose** Coil Ref + Voltage Code, example: 496131 for 24 VDC = **496131C2**

More voltage possibilities can be found in the table of voltage codes at the end of the coil section.

"The housing kit is already included in the valve reference, it is not needed to order it separately."

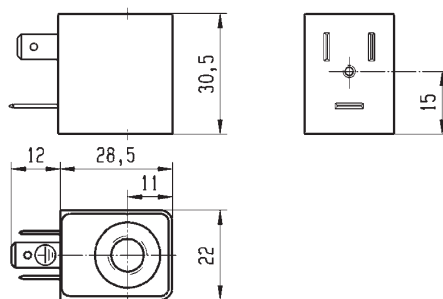

## COILS

### COIL GROUP

# 1.2

## COILS FOR DIN PLUG CONNECTION



### DOUBLE FREQUENCY COIL 22 mm

This coil can be mounted with every Parker solenoid valves corresponding to the specified Coil Group.  
See column "Coil Group" within valve pages.

This coil is designed for valves equipped with a miniature tube assembly (2000 series valves). This is an encapsulated assembly comprising a coil, integral magnetic iron path and snap-on plug connection.

The synthetic material encapsulation provides an effective compact housing, offering full protection against dust, oil, water, etc. Ease of mounting in confined space - offers shock and corrosion protection - simplifies conversion of existing equipment to other requirements, etc. Coil conforms to the IEC/CENELEC safety standards and complies with European low-voltage directive.

DIN plug connector included.



Specification		Double frequency			
Reference		496482			
Coil group		1.2			
Degree of protection		IP65 according to IEC / EN 60529 standards (with DIN plug).			
Class of insulation		F 155°C			
Electrical connection		The coil is connected with a 2 P + E plug according to EN 175301-803 type B.			
Ambient temperature		-40°C to +50°C The application is limited also by the temperature range of the valve.			
Elect. Power	DC	Pn (hot)	3 W		
		P (cold) 20°C	-		
	AC	Pn (holding)	3 W		
		Attraction cold	-		
Weight		75 g			
Voltages "Un"		VAC/Hz	Code	VDC	Code
-10% to +10% of the Un		24/50-60	P0	24 V	C2
		110/50-60	P2	48 V	C4
		230/50-60	P9	110 V	C5
		48/50-60	S4		

**To Order a Coil choose** Coil Ref + Voltage Code, example: 496482 for 24 VDC = **496482C2**

More voltage possibilities can be found in the table of voltage codes at the end of the coil section.

"The housing kit is already included in the valve reference, it is not needed to order it separately."

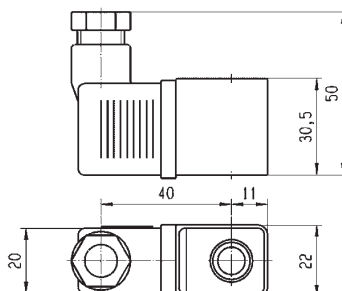

**COIL GROUP**

# 1.3

## COILS FOR DIN PLUG CONNECTION



### WB COIL SERIES 22 mm

These coils can be mounted with every Parker solenoid valves corresponding to the specified Coil Group. See column "Coil Group" within valve pages.

These coils can be mounted with the majority of type 2 operators. Coil manufactured with H class copper wire, moulded in thermoplastic material polyester with 30% glass fiber. IP65 protection rate with DIN 43650A three pin connector and appropriate gasket.

The synthetic material encapsulation provides an effective compact housing, offering full protection against dust, oil, water, etc. Coils conforms to the IEC/ CENELEC safety standards and complies with European low-voltage directive. For UL recognized version: UL file MH19410.

DIN plug connector to be ordered separately (see coil accessories section).



Specification		Standard		UL recognized version		High Power	
Ref. (without DIN plug)		WB4.5 for AC WB5.0 for DC		WB4.5 UR WB5.0 cURus (only 24 VDC)		WB8.0	
Coil Group				1.3			
Degree of protection		IP65 according to IEC / EN 60529 standards (with DIN plug + gasket)					
Class of insulation		F 155°C		F 155°C		F 155°C	
Electrical connection		The coil is connected with a 2 P + E plug according to EN 175301-803 type B.					
Ambient temperature		-10°C to +50°C		-10°C to +50°C		-10°C to +50°C	
		The application is limited also by the temperature range of the valve.					
Elect. Power	DC	P (cold) 20°C		-		-	
	AC	Pn (holding)		4.5 W		8 W	
		Attraction cold		7.5 VA		11 VA	
Weight		90 g (without plug)					
Voltages "Un"		WB4.5 VAC/Hz	Order Number	WB4.5 UR VAC/Hz	Order Number	WB8.0 VAC/Hz	Order Number
-10% to +10% of Un for AC - 5% to +10 % for Un DC		100/50-60	302609	115/60	304087	115/50-60	302672
		115/50-60	304260	208-240/60	304089	230/50-60	302674
		230/50-60	304262J	24/60	304086	24/50-60	302670
		110/50	304316				
		WB5.0 VDC	Order Number	WB5.0 cURus VDC	Order Number		
		110 VDC	302660	24 VDC	302654		
		12 VDC	302652				

**To Order a Coil:** Use 6 digits ordering number - **Code Example:** WB8.0 for 115/50-60 = 302672  
More voltage possibilities can be found in the table of voltage codes at the end of the coil section.

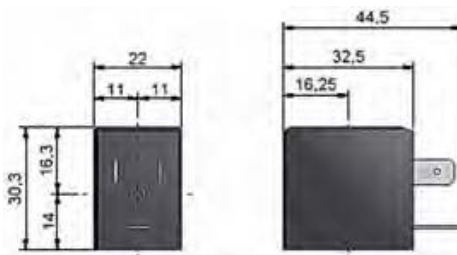

## COILS

### COIL GROUP

# 20.1

## COILS FOR DIN PLUG CONNECTION



### ZB COIL SERIES

These coils can be mounted with every Parker solenoid valves corresponding to the specified Coil Group. See column "Coil Group" within valve pages.

Coil manufactured with H class copper wire, moulded in thermoplastic material polyester with 30% glass fiber.

IP65 protection rate with EN 175301-803:2006-A. Three pin connector.

This coil conforms to the IEC/CENELEC safety standards and complies with European low-voltage directive.

For UL recognized version: UL file MH19410.

DIN plug connector to be ordered separately (see coil accessories section).



Specification		Standard			UL recognized version		
Reference (without DIN plug)		ZB09/ZB12			ZB09 for AC only		
Coil Group		20.1					
Degree of protection		IP65 according to IEC / EN 60529 standards (with DIN plug and gasket)					
Class of insulation		F 155°C					
Electrical connection		The coil is connected with a 2 P + E plug according to EN 175301-803 - type A					
Ambient temperature		-10°C to +50°C The application is limited also by the temperature range of the valve.					
Elect. Power	DC	P (cold) 20°C	12 W				
	AC	P (cold) 20°C	9 W				
		Attraction cold	25 VA				
Weight		130 g					
Voltages "Un"		VAC/Hz	Order Number	VDC	Order Number	VAC/Hz	Order Number
-10% to +10% of Un for AC - 5 % to + 10 % for Un DC.		ZB09 24/50-60	304004	ZB12 12DC	304018	ZB09 24/60	304048
		ZB09 12/50-60	304002	ZB12 24DC	304020	ZB09 110-120/60	304011
		ZB09 230/50-60	304012	ZB12 110DC	304022	ZB09 208-240/60	304051
		ZB09 115/50-60	304010	ZB12 48VDC	304021		
		ZB09 100/50-60	304009				
		ZB09 240/50-60	304014				
		ZB09 48/50-60	304008				
		ZB09 110-120/60	304011				
		ZB09 380/50-60	304016				

**To Order a Coil:** Use 6 digits ordering number - Code Example: ZB09 24/50-60 = 304004

More voltage possibilities can be found in the table of voltage codes at the end of the coil section.

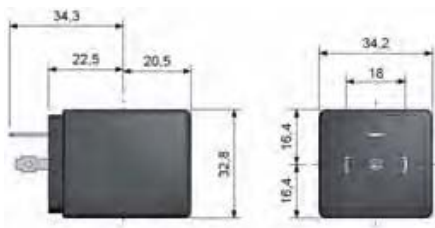

**COIL GROUP**

# 20.2

## COILS FOR DIN PLUG CONNECTION



### ZB/ZH HIGH POWER - HIGH TEMPERATURE COIL SERIES

These coils can be mounted with every Parker solenoid valves corresponding to the specified Coil Group.

See column "Coil Group" within valve pages.

Coil manufactured with H class copper wire, moulded in thermoplastic material polyester with 30% glass fiber.

IP65 protection rate with EN 175301-803:2006-A. Three pin connector.

This coil conforms to the IEC/CENELEC safety standards and complies with European low-voltage directive.

DIN plug connector to be ordered separately (see coil accessories section).



Specification		High power	High temperature + high power						
Ref. (without DIN plug)		ZB14/ZB16	ZH14/ZH16						
Coil Group		20.2							
Degree of protection		IP65 according to IEC / EN 60529 standards (with DIN plug and gasket)							
Class of insulation		H 180°C							
Electrical connection		The coil is connected with a 2 P + E plug according to EN 175301-803 - type A							
Ambient temperature		ZB14/ZB16 -10°C to +50°C			ZH14/ZH16 -10°C to +80°C				
		The application is limited also by the temperature range of the valve.							
Elect. Power	DC	P (cold) 20°C		16 W					
	AC	P (cold) 20°C		14 W					
		Attraction cold		33 VA					
Weight		130 g (without plug)							
Voltages "Un"		VAC/Hz	Order Number	VDC	Order Number	VAC/Hz	Order Number	VDC	Order Number
-10% to +10% of Un for AC - 5% to + 10% for Un DC		ZB14 12/50-60	304052	ZB16 12DC	304068	ZH14 24/50-60	304100	ZH16 24DC	304112
		ZB14 24/50-60	304054	ZB16 24DC	304070	ZH14 115/50-60	304102	ZH16 12DC	304110
		ZB14 100/50-60	304084	ZB16 110DC	304072	ZH14 230/50-60	304104		
		ZB14 115/50-60	304060						
		ZB14 230/50-60	304062						
		ZB14 240/50-60	304064						
		ZB14 380/50-60	304066						
		ZB14 48/50-60	304058						

**To Order a Coil:** Use 6 digits ordering number - **Code Example:** ZH16 for 24 VDC = **304112**

More voltage possibilities can be found in the table of voltage codes at the end of the coil section.

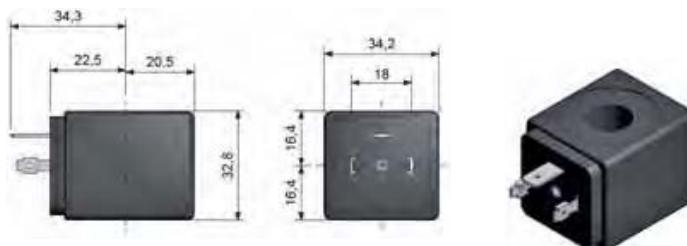

## COILS

### COIL GROUP

# 21.0

## COILS FOR DIN PLUG CONNECTION



### JB COIL SERIES

These coils can be mounted with every Parker solenoid valves corresponding to the specified Coil Group.  
See column "Coil Group" within valve pages.

Coil manufactured with H class copper wire, moulded in thermoplastic material polyester with 30% glass fiber.

IP65 protection rate with EN 175301-803:2006-A. Three pin connector.

This coil conforms to the IEC/CENELEC safety standards and complies with European low-voltage directive.

DIN plug connector to be ordered separately (see coil accessories section).



Specification		Standard			
Ref. (without DIN plug)		JB14/JB16			
Coil Group		21.0			
Degree of protection		IP65 according to IEC / EN 60529 standards (with DIN plug and gasket)			
Class of insulation		F 155°C			
Electrical connection		The coil is connected with a 2 P + E plug according to EN 175301-803 - Type A			
Ambient temperature		-10°C to +50°C The application is limited also by the temperature range of the valve.			
Elect. Power	DC	P (cold) 20°C	16 W		
	AC	P (cold) 20°C	14 W		
		Attraction cold	55 VA		
Weight		130 g (without plug)			
Voltages "Un"		VAC/Hz	Order Number	VDC	Order Number
-10% to +10% of Un for AC - 5 % to + 10 % for Un DC.		JB14 24/50-60	304900	JB16 12DC	304945
		JB14 115/50-60	304910	JB16 24DC	304950
		JB14 230/50-60	304915	JB16 196DC	304958
		JB14 240/50-60	304920		

**To Order a Coil:** Use 6 digits ordering number - **Code Example:** JB16 for 12 VDC = 304945

More voltage possibilities can be found in the table of voltage codes at the end of the coil section.

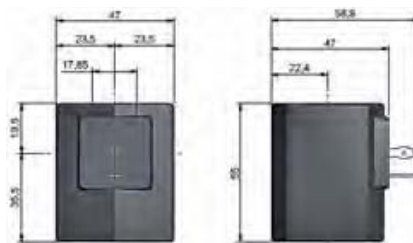

**COIL GROUP**
**22.0**
**COILS FOR  
DIN PLUG CONNECTION**

## KT/KH COIL SERIES

These coils can be mounted with every Parker solenoid valves corresponding to the specified Coil Group.  
See column "Coil Group" within valve pages.

Coil manufactured with H class copper wire, moulded in thermoplastic material polyester with 30% glass fiber.

**IP65 protection rate with EN 175301-803:2006-A. Three pin connector.**

This coil conforms to the IEC/CENELEC safety standards and complies with European low-voltage directive.

DIN plug connector to be ordered separately (see coil accessories section).



Specification		Standard			High Temperature	
Ref. (without DIN plug)		<b>KT09/KT10</b>			<b>KH09</b>	
Coil Group		<b>22.0</b>				
Degree of protection		IP65 according to IEC / EN 60529 standards (with DIN plug and gasket)				
Class of insulation		F 155°C			H 180°C	
Electrical connection		The coil is connected with a 2 P + E plug according to EN 175301-803 - Type A				
Ambient temperature		-10°C to +50°C The application is limited also by the temperature range of the valve.			-10°C to +80°C	
Elect. Power	DC	P (cold) 20°C	10 W			-
	AC	P (cold) 20°C	9 W			9 W
		Attraction cold	20 VA			20 VA
Weight		150 g (without plug)				
Voltages "Un"		VAC/Hz	Order Number	VDC	Order Number	VAC/Hz
-10% to +10% of Un for AC - 5 % to + 10 % for Un DC		KT09 24/50	<b>304621</b>	KT10 12DC	<b>304666</b>	KH09 24/50
		KT09 115/50	<b>304631</b>	KT10 24DC	<b>304971</b>	KH09 230/50
		KT09 208-230/60	<b>304656</b>			
		KT09-230/50	<b>304639</b>			
		KT09 240/50	<b>304641</b>			
						<b>304746</b> <b>304748</b>

**To Order a Coil:** Use 6 digits ordering number - **Code Example:** KT10 for 12VDC = **304666**

More voltage possibilities can be found in the table of voltage codes at the end of the coil section.



## COILS

### COIL GROUP

# 23.0

## COILS FOR DIN PLUG CONNECTION



### XT09 COIL SERIES

This coil can be mounted with every Parker solenoid valves corresponding to the specified Coil Group.  
See column "Coil Group" within valve pages.

Coil manufactured with H class copper wire, moulded in thermoplastic material polyester with 30% glass fiber. IP54 protection rate with special 2P+E connection. Special plug with integrated powercord available separately.

This coil conforms to the IEC/CENELEC safety standards and complies with European low-voltage directive.

DIN plug connector to be ordered separately (see coil accessories section).



Specification		For Heating Applications	
Ref. (without DIN plug)		XT09	
Coil Group		23.0	
Degree of protection		IP54 according to IEC / EN 60529 standards (with special plug supplied separately)	
Class of insulation		F 155°C	
Electrical connection		Special 2 P + E plug connection	
Ambient temperature		-10°C to +50°C The application is limited also by the temperature range of the valve.	
Elect. Power	DC	P (cold) 20°C	-
	AC	P (cold) 20°C	9 W
		Attraction cold	22 VA
Weight		150 g (without plug)	
Voltages "Un"		VAC/Hz	Order Number
-10% to +10% of Un for AC		XT09 230/50	304776

**To Order a Coil:** Use 6 digits ordering number - **Code Example:** XT09 230/50 = 304776

More voltage possibilities can be found in the table of voltage codes at the end of the coil section.

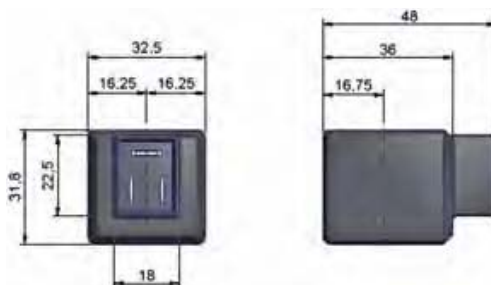

**COIL GROUP**

# 24.0

## COILS FOR DIN PLUG CONNECTION



### D4 SERIES - UL COILS 32 mm

This coil is UL-approved as a recognized component for the insulation Class 155, conforms to the IEC/CENELEC safety standards and complies with European low-voltage directive.

DIN plug connector to be ordered separately (see coil accessories section).



Specification		UL Recognized			
Reference (without DIN plug)		<b>D4 Series</b>			
Coil group		<b>24.0</b>			
Degree of protection		IP65 according to IEC / EN 60529 standards (with DIN plug)			
Class of insulation		F 155°C			
Electrical Connection		The coil is connected with a 2 P + E plug according to EN 175301-803 type A			
Ambient temperature		-40°C to +50°C The application is limited also by the temperature range of the valve.			
Elect. Power	DC	Pn (hot)	12 W		
		P (cold) 20°C	16 W		
	AC	Pn (holding)	11 W		
		Attraction cold	13VA		
Weight		130 g			
Voltages "Un"		VAC/Hz	Code	VDC	Code
-10% to +10% of Un for AC - 5 % to + 10 % for Un DC.		24/60	D4E	24	D4B
		110/50 - 120/60	D4F		
		220/50 - 240/60	D4G		

**To Order a Coil:** Use 6 digits ordering number - **Code Example:** D4 for 24VAC/60Hz = **D4E**  
More voltage possibilities can be found in the table of voltage codes at the end of the coil section.

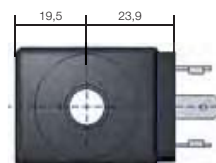

# COILS

## COIL GROUP

# 24.0

## COILS FOR DIN PLUG CONNECTION



### D5 COIL SERIES 32 mm

Encapsulated in synthetic material, Connector for 2P+E according with DIN EN 175301-803, Form A, IP65 degree of protection to be considered with connector plug only.

This coil conforms to the IEC/CENELEC safety standards and complies with European low-voltage directive.

DIN plug connector to be ordered separately (see coil accessories section).



Specification		Mono Frequency VDE Coil			
Reference (without DIN plug)		D5 Series			
Coil group		24.0			
Degree of protection		IP65 according to IEC / EN 60529 standards (with DIN plug)			
Class of insulation		F 155°C			
Electrical connection		The coil is connected with a 2 P + E plug according to EN 175301-803 type A.			
Ambient temperature		-40°C to +50°C The application is limited also by the temperature range of the valve.			
Elect. Power	DC	Pn (hot)	9 W		
		P (cold) 20°C	-		
	AC	P (cold) 20°C	8 W		
		Attraction cold	40 VA		
Weight		130 g			
Voltages "Un"		VAC/Hz	Code	VDC	Code
-10% to +10% of Un for AC - 5 % to + 10 % for Un DC.		24/50	D5H	24	D5B
		110/50	D5XA5		
		220-230/50	D5L		
		24/60	D5E		
		230/60	D5XJ3		
		115/60	D5XK8		

**To Order a Coil:** Use 6 digits ordering number - **Code Example:** D5 for 24 VAC/60 Hz = **D5E**  
More voltage possibilities can be found in the table of voltage codes at the end of the coil section.

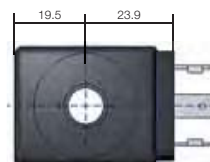

**COIL GROUP**
**24.0**
**COILS FOR  
DIN PLUG CONNECTION**

**XS03 COIL SERIES 32 mm**

Encapsulated in synthetic material, Connector for 2P+E according with DIN EN 175301-803, Form A, IP65 degree of protection to be considered with connector plug only.

This coil conforms to the IEC/CENELEC safety standards and complies with European low-voltage directive.

DIN plug connector to be ordered separately (see coil accessories section).



Specification		Bi- Frequency VDE Coil	
Reference (without DIN plug)		<b>XS03 Series</b>	
Coil group		<b>24.0</b>	
Degree of protection		IP65 according to IEC / EN 60529 standards (with DIN plug)	
Class of insulation		F 155°C	
Electrical Connection		The coil is connected with a 2 P + E plug according to EN 175301-803 type A	
Ambient temperature		-40°C to +50°C The application is limited also by the temperature range of the valve.	
Elect. Power	DC	Pn (hot)	-
		P (cold) 20°C	-
	AC	Pn (holding)	9 W
		Attraction cold	32 VA
Weight		130 g	
Voltages "Un"		<b>VAC/Hz</b>	<b>Code</b>
-10% to +10% of Un for AC		24/50 - 24/60	XS03M
		110-115/50 - 120/60	XS03XS5
		220-240/50 - 240/60	XS03XS6

**To Order a Coil:** Use 6 digits ordering number - **Code Example:** XS03 for 24/50-24/60 = **XS03M**  
More voltage possibilities can be found in the table of voltage codes at the end of the coil section.

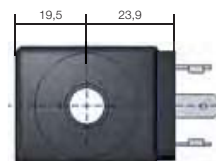

## COILS

### COIL GROUP

# 10.1

## COILS FOR DIN PLUG CONNECTION



### COIL FOR OIL AND GAS 37 mm

This coil can be mounted with every Parker solenoid valves corresponding to the specified Coil Group.

See column "Coil Group" within valve pages.

This is an encapsulated assembly comprising a coil, integral magnetic iron path and snap-on plug connection.

The synthetic material encapsulation provides an effective compact housing, offering full protection against dust, oil, water, etc.

Ease of mounting in confined space - offers shock and corrosion protection - simplifies conversion of existing equipment to other requirements, etc.

Coils conform to the IEC/CENELEC safety standards and complies with European low-voltage directive. DIN plug connector included (The AC electrical connection is delivered with a rectifier bridge).



Specification		Coil for Oil and Gas			
Reference (with DIN plug)		496895			
Coil group		10.1			
Degree of protection		IP65 according to IEC / EN 60529 standards			
Class of insulation		H 180°C			
Electrical connection		With DIN plug 492459 (AC) or 486586 (DC)			
Ambient temperature		-40°C to +50°C The application is limited also by the temperature range of the valve.			
Elect. Power	DC	Pn (hot)	8 W		
		P (cold) 20°C	-		
	AC	Pn (holding)	8 W		
		Attraction cold	-		
Weight		273 g			
Voltages "Un"		VAC/Hz	Code	VDC	Code
-10% to +10% of the Un		230/50-60	P9	24	C2
		110/50-60	P2	48	C4
		24/50-60	P0	110	C5
		48/50-60	S4		

**To Order a Coil choose** Coil Ref + Voltage Code, example: 496895 for 24 VDC = **496895C2**

More voltage possibilities can be found in the table of voltage codes at the end of the coil section.

The fixing nut (housing kit) is already included in the coil kit.

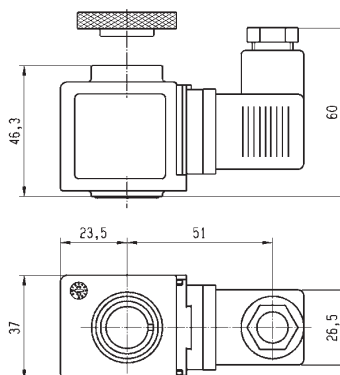

**COIL GROUP**
**20.1**
**COILS WITH FLYING LEADS**

**YB COIL SERIES IP67**

These coils can be mounted with every Parker solenoid valves corresponding to the specified Coil Group. See column "Coil Group" within valve pages.

Coil manufactured with H class copper wire, moulded in thermoplastic material polyester with 30% glass fiber.

IP67 protection rate. Electrical connection: 2 x 1000 mm cables.

This coil conforms to the IEC/CENELEC safety standards and complies with European low-voltage directive.

For UL recognized version: UL file MH19410.

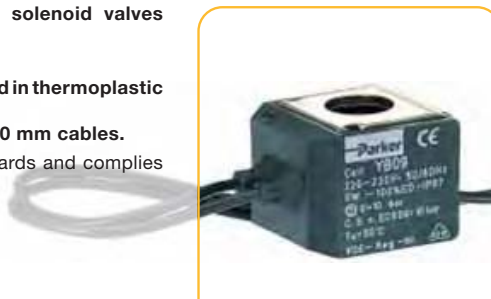

Specification		Standard			UL recognized version		
Reference		YB09/YB12			YB09		
Coil Group		20.1					
Degree of protection		IP67 according to IEC / EN 60529 standards					
Class of insulation		F 155°C					
Electrical connection		The coil is connected with a 2 x 1000 mm flying leads integrated.					
Ambient temperature		-10°C to +50°C The application is limited also by the temperature range of the valve.					
Elect. Power	DC	P (cold) 20°C	12 W				
	AC	Pn (holding)	9 W	9 W			
		Attraction cold	24 VA	24 VA			
Weight		150 g					
Voltages "Un"		VAC/Hz	Order Number	VDC	Order Number	VAC/Hz	Order Number
-10% to +10% of Un for AC - 5 % to + 10 % for Un DC.		YB09 115/50-60	<b>304396</b>	YB12 12DC	<b>304412</b>	YB09 24/60	<b>304481</b>
		YB09 230/50-60	<b>304398</b>	YB12 24DC	<b>304416</b>	YB09 110-120/60	<b>304488</b>
		YB09 24/50-60	<b>304390</b>			YB09 208-240/60	<b>304483</b>
		YB09 240/50-60	<b>304400</b>				

**To Order a Coil:** Use 6 digits ordering number - **Code Example:** YB09 for 24 VAC/60 Hz = **304481**  
More voltage possibilities can be found in the table of voltage codes at the end of the coil section.

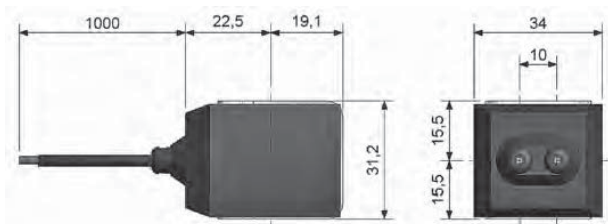

# COILS

## COIL GROUP

# 24.0

## COILS WITH FLYING LEADS



### LA COIL SERIES 32 mm IP67

Encapsulated in synthetic material. Degree of protection IP67 as per IEC/EN60529.

Connection: 2 x 500 mm cables.

This coil conforms to the IEC/CENELEC safety standards and complies with European low-voltage directive.



Specification		Coil with two 500 mm flying leads			
Reference		LA Series			
Coil group		24.0			
Degree of protection		IP67 according to IEC / EN 60529 standards			
Class of insulation		F 155°C			
Ambient temperature		-10°C to +50°C The application is limited also by the temperature range of the valve.			
Elect. Power	DC	Pn (hot)	9 W		
		P (cold) 20°C	-		
	AC	Pn (holding)	9 W		
		Attraction cold	32 VA		
Weight		180 g			
Voltages "Un"		VAC/Hz	Code	VDC	Code
-10% to +10% of Un for AC		24/50 - 24/60	LAM	24	LAB
-5% to +10% for Un DC.		110-115/50 - 120/60	LAXS5		
		220-240/50 - 240/60	LAXS6		

**To Order a Coil:** Use 6 digits ordering number - **Code Example:** LA Series for 24 VDC = LAB  
More voltage possibilities can be found in the table of voltage codes at the end of the coil section.

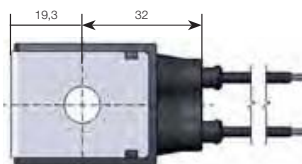
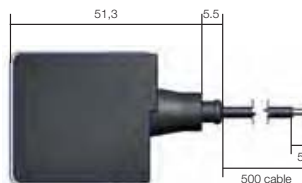
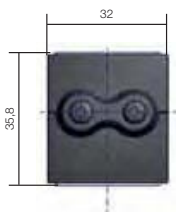

**COIL GROUP**
**24.0**
**COILS WITH  
FLYING LEADS**

## LB-LC COIL SERIES 32 mm UL IP67

Encapsulated in synthetic material. Degree of protection IP67 as per IEC/EN60529.

Connection: 2 x 500mm cables.

This coil is UL-approved as a recognized component for the insulation Class 155, conforms to the IEC/CENELEC safety standards and complies with European low-voltage directive.



Specification		UL Coil with two 500 mm flying leads			
Reference		LB-LC Series			
Coil group		24.0			
Degree of protection		IP67 according to IEC / EN 60529 standards			
Class of insulation		F 155°C			
Ambient temperature		-10°C to +50°C The application is limited also by the temperature range of the valve.			
Elect. Power	DC	Pn (hot)	16 W		
		P (cold) 20°C	-		
	AC	Pn (holding)	13-14 W		
		Attraction cold	40 VA		
Weight		180 g			
Voltages "Un"		VAC/Hz	Code	VDC	Code
-10% to +10% of Un for AC		24/60	LBE	24	LCB
-5% to +10% for Un DC		110/50 - 120/60	LBF		
		208-240/60	LBXU3		
		220/50 240/60	LBG		

**To Order a Coil:** Use 6 digits ordering number - **Code Example: LB-LC for 24 VDC = LCB**

More voltage possibilities can be found in the table of voltage codes at the end of the coil section.

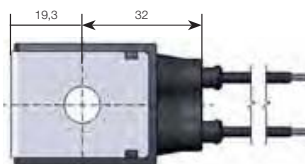
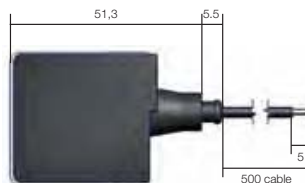
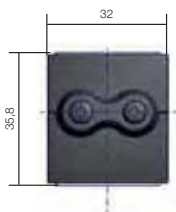

## COILS

### COIL GROUP

# 2.0/2.1

## COILS WITH FLYING LEADS



### COIL 32 mm IP67

This coil can be mounted with every Parker solenoid valves corresponding to the specified Coil Group. See column "Coil Group" within valve pages.

This is an encapsulated assembly comprising a coil, integral magnetic iron path and snap-on plug connection.

The synthetic material encapsulation provides an effective compact housing, offering full protection against dust, oil, water, etc.

Ease of mounting in confined space - offers shock and corrosion protection - simplifies conversion of existing equipment to other requirements, etc.

Coils conform to the IEC/CENELEC safety standards and complies with European low-voltage directive.



Specification		Coil with two 500 mm flying leads			
Reference		496081			
Coil Group		2.0 / 2.1			
Degree of protection		IP67 according to IEC / EN 60529 standards			
Class of insulation		F 155°C			
Ambient temperature		-40 °C to +50°C The application is limited also by the temperature range of the valve.			
Elect. Power	DC	Pn (hot)	9 W		
		P (cold) 20°C	-		
	AC	Pn (holding)	9 W		
		Attraction cold	32 VA		
Weight		180 g			
Voltages "Un"		VAC/Hz	Order Number	VDC	Order Number
-10% to +10% of Un for AC		24/50 - 24/60	439816	24	439818
- 5 % to + 10 % for Un DC		110-115/50 - 120/60	439820	12	439814
		220-240/50 - 240/60	439822		

**To Order a Coil:** Use 6 digits ordering number - **Code Example:** 496081 for 24 VDC = **439818**  
More voltage possibilities can be found in the table of voltage codes at the end of the coil section.

For Parker Lucifer® valves please order housing Ref: 2995

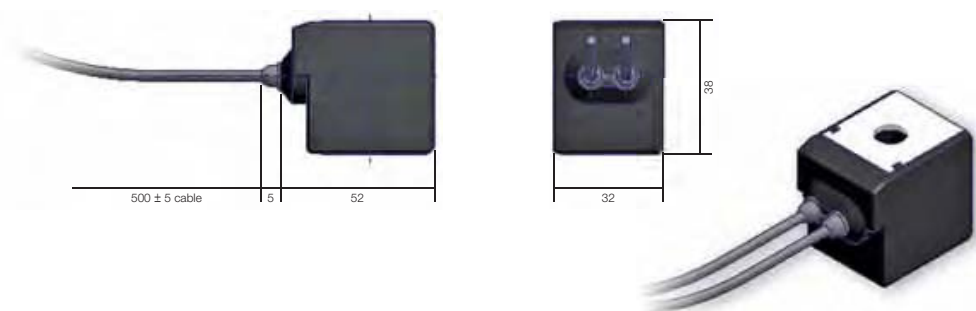

**COIL GROUP**
**2.0/2.2**
**COILS WITH FLYING LEADS**

**COIL 32 mm IP67 UL**

This coil can be mounted with every Parker solenoid valves corresponding to the specified Coil Group. See column "Coil Group" within valve pages.

This is an encapsulated assembly comprising a coil, integral magnetic iron path and snap-on plug connection.

The synthetic material encapsulation provides an effective compact housing, offering full protection against dust, oil, water, etc.

Ease of mounting in confined space - offers shock and corrosion protection - simplifies conversion of existing equipment to other requirements, etc.

Coils conform to the IEC/CENELEC safety standards and complies with European low-voltage directive.



Specification		UL Coil with two 500 mm flying leads			
Reference		496082			
Coil Group		2.0 / 2.2			
Degree of protection		IP67 according to IEC / EN 60529 standards			
Class of insulation		F 155°C			
Ambient temperature		-40°C to +50°C The application is limited also by the temperature range of the valve.			
Elect. Power	DC	Pn (hot)	16 W		
		P (cold) 20°C	-		
	AC	Pn (holding)	13-14 W		
		Attraction cold	40 VA		
Weight		180 g			
Voltages "Un"		VAC/Hz	Order Number	VDC	Order Number
-10% to +10% of Un for AC		24/60	439826	24	439832
- 5% to + 10 % for Un DC		110/50 - 120/60	439828	12	439830
		208-240/60	439824		
		220/50 - 240/60	439834		

**To Order a Coil:** Use 6 digits ordering number - **Code Example:** 496082 for 24 VDC= **439832**  
More voltage possibilities can be found in the table of voltage codes at the end of the coil section.

For Parker Lucifer® valves please order housing Ref: 2995

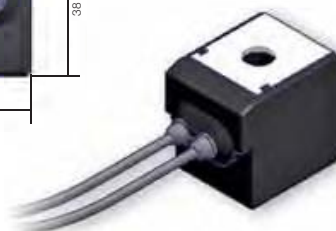
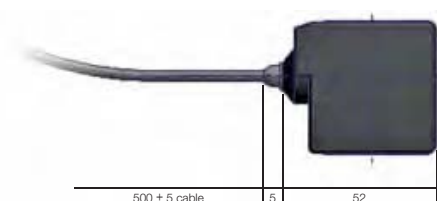

## COILS

### COIL GROUP

# 2.0/2.1

## COILS WITH SCREW TERMINALS



### STANDARD COILS 40 mm

These coils can be mounted with every Parker Solenoid Valves corresponding to the specified Coil Group. See column "Coil Group" within valve pages.

They can be mounted with all metal housings.

The coil winding is completely encapsulated in synthetic material.

Easy mounting in confined spaces. Electrical connection with screw terminals for wire up to 1.5 mm<sup>2</sup>.

Coils conform to the IEC/CENELEC safety standards and complies with European low-voltage directive.



Specification		Standard			Double Frequency		
Reference		481000			483520		
Coil Group		2.0 / 2.1					
Class of insulation		F 155°C					
Ambient temperature		-40°C to +50°C The application is limited also by the temperature range of the valve..					
Elect. Power	DC	Pn (hot)	8W		-		
		P (cold) 20°C	9W		-		
	AC	Pn (holding)	8W		9W		
		Attraction cold	32 VA (9 W)		36 VA (10 W)		
Weight		130 g			130 g		
Voltages "Un"		VAC/Hz	Code	VDC	Code	VAC/Hz	Code
-10% to +10% of the Un		24/50	A2	24	C2	24/50-60	P0
(-15 % to +5 %		48/50	A4	48	C4	220-240/50-240/60	S6
for double-frequency coil		110/50-115/50	0A	110	C5		
with voltage code		220/50-230/50	3D				
S6 if 240 V/50/Hz is used).							

**To Order a Coil choose** Coil Ref + Voltage Code, example: 4828 for 24 VDC = 481000C2

More voltage possibilities can be found in the table of voltage codes at the end of the coil section.

These coils must be used with suitable housings, see examples below:

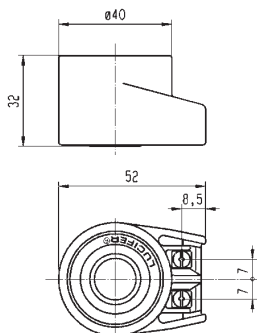

Ref. 4270 - Protection IP 44 according to IEC / EN 60529 standard (with cable gland)



Ref. 4538 - Protection IP 67 according to IEC / EN 60529 standard



**COIL GROUP**
**2.0/2.2**
**COILS WITH  
SCREW TERMINALS**

**HIGH POWER COILS 40 mm**

This coil can be mounted with every Parker Solenoid Valves corresponding to the specified Coil Group. See column "Coil Group" within valve pages.

They can be mounted with all metal housings.

The coil winding is completely encapsulated in synthetic material.

Easy mounting in confined spaces. Electrical connection with screw terminals for wire up to 1.5 mm<sup>2</sup>.

Coils conform to the IEC/CENELEC safety standards and complies with European low-voltage directive.



Specification		High Power	
Reference		481044	
Coil Group		2.0 / 2.2	
Class of insulation		F 155°C	
Ambient temperature		-40°C to +50°C The application is limited also by the temperature range of the valve.	
Elect. Power	DC	Pn (hot)	-
		P (cold) 20°C	-
	AC	Pn (holding)	14 W
		Attraction cold	56 VA (20 W)
Weight		130 g	
Voltages "Un"		VAC/Hz	Code
-10% to +10% of the Un		24/50	A2
		110/50	A5
		220/50	A7
		230/50	F4

**To Order a Coil choose** Coil Ref + Voltage Code, example: 481044 for 24VAC/50Hz = **481044A2**

More voltage possibilities can be found in the table of voltage codes at the end of the coil section.

These coils must be used with suitable housings, see examples below:

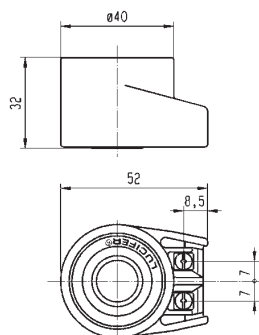

**Ref. 4270** - Protection **IP 44** according to IEC / EN 60529 standard (with cable gland)



**Ref. 8520** - Protection **IP 67** according to IEC / EN 60529 standard



## COILS

COIL GROUP  
**2.0/2.1**  
**2.2**

## COILS WITH SCREW TERMINALS



### HIGH TEMPERATURE COILS 40 mm

These coils can be mounted with every Parker Solenoid Valves corresponding to the specified Coil Group. See column "Coil Group" within valve pages.

They can be mounted with all metal housings.

The coil winding is completely encapsulated in synthetic material.

Easy mounting in confined spaces. Electrical connection with screw terminals for wire up to 1.5 mm<sup>2</sup>.

Coils conform to the IEC/CENELEC safety standards and complies with European low-voltage directive.



Specification		High Temperature			High Temperature & High Power				
Reference		485100			486265				
Coil Group		2.0 / 2.1			2.0 / 2.2				
Class of insulation		H 180°C							
Ambient temperature		-40°C to +50°C							
		The application is limited also by the temperature range of the valve.							
Elect. Power	DC	Pn (hot)	8 W			14 W			
		P (cold) 20°C	9 W			21 W			
	AC	Pn (holding)	8 W			14 W			
		Attraction cold	32 VA (9 W)			56 VA (20 W)			
Weight		140 g							
Voltages "Un"		VAC/Hz	Code	VDC	Code	VAC/Hz	Code	VDC	Code
-10% to +10% of the Un		24/50	A2	24	C2	24/50	A2	12	C1
		380/50-440/60	5P			110/50	A5	24	C2
		220/50-230/50	3D			220/50	A7	48	C4
						230/50	F4		

**To Order a Coil choose** Coil Ref + Voltage Code, example: 485100 for 24VAC/50Hz = **485100A2**

More voltage possibilities can be found in the table of voltage codes at the end of the coil section.

These coils must be used with suitable housings, see examples below:

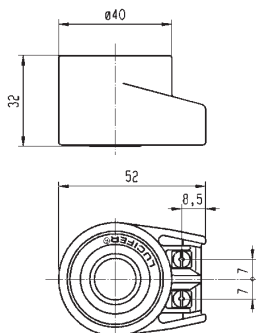

Ref. 4270 - Protection IP 44 according to IEC / EN 60529 standard (with cable gland)



Ref. 8520 - Protection IP 67 according to IEC / EN 60529 standard



**COIL GROUP**

# 14.1

## COILS WITH SCREW TERMINALS



### HIGH TEMPERATURE & HIGH POWER COILS 40 mm OIL BURNER

This coils can be mounted with every Parker Solenoid Valves corresponding to the specified Coil Group. See column "Coil Group" within valve pages.

It can be mounted with all metal housings.

The coil winding is completely encapsulated in synthetic material.

Easy mounting in confined spaces. Electrical connection with screw terminals for wire up to 1.5 mm<sup>2</sup>.

Coil conform to the IEC/CENELEC safety standards and complies with European low-voltage directive.

This coil is used only in safety application according to DIN/EN/ISO 23551-1:2009-10 (Oil burners)



Specification		High Temperature & High Power	
Reference		483824	
Coil Group		14.1	
Class of insulation		H 180°C	
Ambient temperature		-40°C to +50°C The application is limited also by the temperature range of the valve.	
Elect Power	DC	Pn (hot)	19 W
		P (cold) 20°C	19 W
	AC	Pn (holding)	19 W
		Attraction cold	56 VA (20 W)
Weight		130 g	
Voltages "Un"		VAC/Hz	Code
-10% to +10% of the Un		120/50	A6
		240/50	A8
		110/60	B5
		220/60	B7
		58/50-60/60	T6
		55/60	4J

**To Order a Coil choose** Coil Ref + Voltage Code, example: 483824 for 120/50 = **483824A6**

More voltage possibilities can be found in the table of voltage codes at the end of the coil section.

These coils must be used with suitable housings, Ref: 8760.24 and Ref: 8520.23

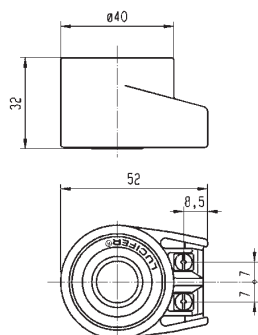

Ref. 8760.24



Ref. 8520.23



# COILS

## COIL GROUP

# 14.3

## COILS WITH SCREW TERMINALS



### HIGH TEMPERATURE & HIGH POWER COILS 40 mm OIL BURNER

This coils can be mounted with every Parker Solenoid Valves corresponding to the specified Coil Group. See column "Coil Group" within valve pages.

It can be mounted with all metal housings.

The coil winding is completely encapsulated in synthetic material.

Easy mounting in confined spaces. Electrical connection with screw terminals for wire up to 1.5 mm<sup>2</sup>.

Coil conform to the IEC/CENELEC safety standards and complies with European low-voltage directive.

This coil is used only in safety application according to DIN/EN/ISO 23551-1:2009-10 (Oil burners)



Specification		High Temperature & High Power	
Reference		483541	
Coil Group		14.3	
Class of insulation		H 180°C	
Ambient temperature		-40°C to +50°C The application is limited also by the temperature range of the valve.	
Elect. Power	DC	Pn (hot)	20 W
		P (cold) 20°C	20 W
	AC	Pn (holding)	20 W
		Attraction cold	56 VA (20 W)
Weight		130 g	
Voltages "Un"		VAC/Hz	Code
-10% to +10% of the Un		120/50	A6
		240/50	A8
		110/60	B5
		220/60	B7
		58/50-60/60	T6
		55/60	4J

To Order a Coil choose Coil Ref + Voltage Code, example: 483541 for 120/50 = 483541A6

More voltage possibilities can be found in the table of voltage codes at the end of the coil section.

These coils must be used with suitable housings, Ref: 8760.24 and Ref: 8520.23

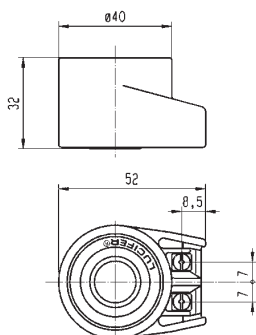

Ref. 8760.24



Ref. 8520.23



**COIL GROUP**
**2.0/2.1**
**COILS WITH SCREW TERMINALS**

**COIL DOUBLE FREQUENCY 40 mm H CLASS**

This coil can be mounted with every Parker Solenoid Valves corresponding to the specified Coil Group. See column "Coil Group" within valve pages.

They can be mounted with all metal housings.

The coil winding is completely encapsulated in synthetic material.

Easy mounting in confined spaces. Electrical connection with screw terminals for wire up to 1.5 mm<sup>2</sup>.

Coils conform to the IEC/CENELEC safety standards and complies with European low-voltage directive.



Specification		Double Frequency 100 V - 200 V	
Reference		488553	
Coil Group		2.0/2.1	
Class of insulation		H 180°C	
Ambient temperature		-40°C to +50°C The application is limited also by the temperature range of the valve.	
Elect. Power	DC	Pn (hot)	-
		P (cold) 20°C	-
	AC	Pn (holding)	9 W
		Attraction cold	-
Weight		130 g	
Voltages "Un"		VAC/Hz	Code
-10% to +10% of the Un		100/50-60	P1
		200/50-60	P6

**To Order a Coil choose** Coil Ref + Voltage Code, example: 488553 for 110/50-60 = **488553P1**

More voltage possibilities can be found in the table of voltage codes at the end of the coil section.

These coils must be used with suitable housings, see examples below:

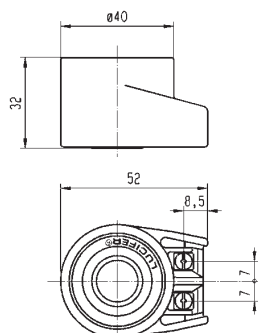

Ref. 4270 - Protection IP 44



Ref. 8520 - Protection IP 54



# COILS

## COIL GROUP

# 4.0

## COILS WITH SCREW TERMINALS



### BISTABLE COILS 40 mm FOR IMPULSE APPLICATIONS

These coils can be mounted with every Parker solenoid valves corresponding to the specified Coil Group.

See column "Coil Group" within valve pages.

These coils are specially designed for Lucifer® bistable (or impulse or magnetic latch) solenoid valves for Heating Applications.

They can be mounted only with the Lucifer® metallic housing 4269 or 4538. The coil winding is completely encapsulated in synthetic material. Easy mounting in confined spaces. Electrical connection with screw terminals for wire up to 1.5 mm<sup>2</sup>.

Coils conform to the IEC/CENELEC safety standards and complies with European low-voltage directive.



Specification		Bistable (Impulse)			
Reference		484990		485400	
Coil Group		4.0			
Class of insulation		F 155°C			
Ambient temperature		-40°C to +50°C			
		The application is limited also by the temperature range of the valve.			
Length of impulses		Switch on (terminals A-B): minimum 50 ms Switch off (terminals A-C): minimum 35 ms			
Electr. Power consumption	DC	Attraction (hot)	-	13 W	
		Attraction (cold)	-	19 W	
		Release (hot)	-	8 W	
		Release (cold)	-	10 W	
	AC	Attraction (hot)	11 W	-	-
		Attraction (cold)	17 W	-	-
		Release (hot)	4 W	-	-
		Release (cold)	7 W	-	-
Weight		150 g			
Voltages "Un"		VAC/Hz	Code	VDC	Code
-10% to +10% of the Un		24/50-24/60	P0	24	C2
		48/50-48/60	S4	48	C4
		110-115/50-115/60	1P	110	C5
		220-230/50-60	3P		

To Order a Coil choose Coil Ref + Voltage Code, example: 485400 for 24 VDC = 485400C2

More voltage possibilities can be found in the table of voltage codes at the end of the coil section.

These coils must be used with suitable housings, see examples below:

#### DIAGRAM

Alternating Current

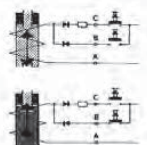

Direct Current

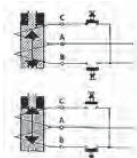

Only an electrical impulse given to terminals A-C reverses the magnetic field. This magnetic field demagnetises the reversible magnet enough to allow the return spring to bring the plunger back to its initial position and close the valve.

Ref. 4269 - Protection IP 44

Ref. 4538 - Protection IP 67



**COIL GROUP**
**13.0**
**COILS WITH ISO-DIN CONNECTORS**

**COILS 12 V - 24 V FOR TRANSPORTATION APPLICATIONS 32 mm**

These coils can be mounted with every Parker solenoid valves corresponding to the specified Coil Group. See column "Coil Group" within valve pages.

**These coils are specially designed for Lucifer® solenoid valves for Transportation Applications.**

They can be mounted with the standard Lucifer® housing 2161 or customized housing.

The coil winding is completely encapsulated in epoxy. Easy mounting and dismantling in confined spaces. Bayonet twist and lock coupling for tight, vibration resistant connection.

Coils conform to the IEC/CENELEC safety standards and complies with European low-voltage directive.



Specification		Transportation			
Reference		496193 with diode		495294 without diode	
Coil Group		13.0			
Degree of protection		IP69K for DIN 400050 part 9			
Ambiant temperature		- 40°C to +120°C The application is limited also by the temperature range of the valve and duty cycle of the valve.			
Insulation Class		F 155°C			
Electrical connection		ISO 15170-A1-2.3-Sn/K2	DIN 72585-A3-2.1		
Elect. Power	DC	Pn (hot)	9 w		
		P (cold) 20°C	-		
	AC	Pn (holding) Attraction cold	-		
Weight		147 g			
Voltages "Un"		VDC	Code	VDC	Code
- 30% to + 30% of the Un		12	C1	12	C1
		24	C2	24	C2

**To Order a Coil choose Coil Ref + Voltage Code, example: 496193 for 24 VDC = 496193C2**

**These coils must be used with suitable housings Ref.2168 for 12Vdc and 2169 for 24 VDC.**

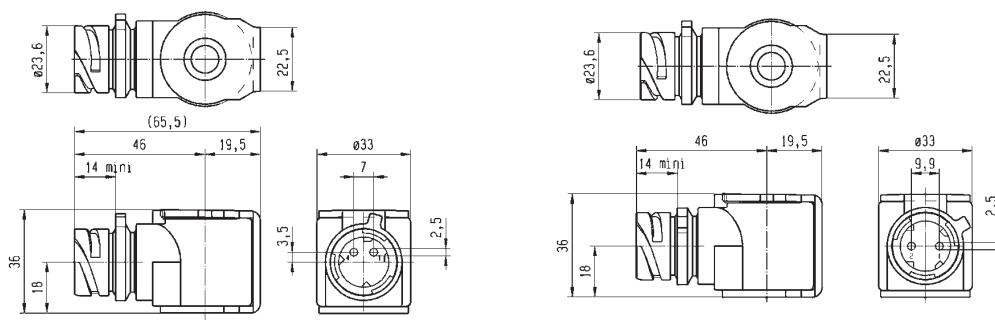

**EXPLOSION PROOF  
ELECTRICAL PARTS**



## TABLE OF CONTENT

### INTRODUCTION

Index for Explosion Proof Electrical Parts.....	442
List of Coil Groups .....	443

### COILS

Coils for DIN plug connection.....	446
Coils with flying leads.....	469
Coils with screw terminal.....	474
Coils with ISO-DIN connector.....	481

### EXPLOSION PROOF ELECTRICAL PARTS

Level of protection "nAc nCc" .....	484
Level of protection "db" .....	492
Level of protection "mb" .....	494
Level of protection "db mb" .....	499
Level of protection "eb" .....	504
Level of protection "eb mb" .....	505
Level of protection "ia" .....	508

<b>HOUSINGS</b> .....	518
-----------------------	-----

<b>COIL ACCESSORIES</b> .....	522
-------------------------------	-----

<b>EXPLOSIVE ENVIRONMENTS</b> .....	524
-------------------------------------	-----

### COIL APPENDICES

Guidance chart for IS-Barriers.....	534
-------------------------------------	-----



**EXPLOSION PROOF  
ELECTRICAL PARTS**

**COIL GROUP**

**1.1**

**ELECTRICAL PARTS  
"nAc nCc"**



**ZONE 2/22**

**ELECTRICAL PART LOW POWER 22 mm**

This coil can be mounted with every Parker ATEX solenoid valves corresponding to the specified Coil Group.

See column "Coil Group" within valve pages.

**Application:**

Control of solenoid valves in dangerous areas where explosion-proof protection Ex nAc nCc IIC T5 is required.

**Benefits:**

The synthetic material encapsulation of the coil provides an effective compact housing, offering full protection against dust, oil, water, etc. Small size for ease of mounting in confined spaces.



<b>Reference</b>		<b>495865</b>			
<b>Certificate</b>		<b>LCIE 05 ATEX 6003 X</b>			
<b>Coil Group</b>		<b>1.1</b>			
<b>Type of protection</b>	<b>Gas</b>	II 3 G Ex nAc nCc IIC T5			
	<b>Dust</b>	II 3 D - Ex tc IIIC - T 95°C			
<b>Degree of protection</b>		<b>IP65</b> (with plug) according to IEC/EN 60529 Standards			
<b>Ambiant temperature</b>		-40°C to +50°C The application is limited also by the temperature range of the valve.			
<b>Insulation Class</b>		F 155°C			
<b>Electrical connection</b>		These coils with connection 2P + G - when mounted together with the supplied Pg 9 plug (delivered with the coil),			
<b>Elect. Power</b>	<b>DC</b>	<b>Pn</b> (hot)	2.5 W		
		<b>P</b> (cold) 20°C	3 W		
	<b>AC</b>	<b>Pn</b> (holding)	2 W		
		Attraction cold	5.7 VA (2.5 W)		
<b>Weight</b>		120 g			
<b>Voltages "Un"</b>		<b>VAC/Hz</b>	<b>Code</b>	<b>VDC</b>	<b>Code</b>
-10% to +10% of the Un		24/50	A2	24	C2
		48/50	A4	48	C4
		110/50-115/50	0A		
		220/50-230/50	3D		

**To Order a Coil choose** Coil Ref + Voltage Code, example: 495865 for 24 VDC = **495865C2**

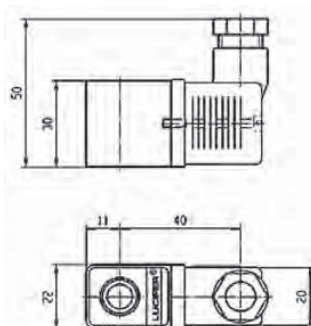

**COIL GROUP**

# 1.2

## ELECTRICAL PARTS "nAc nCc"

**ZONE 2/22**

### ELECTRICAL PART DOUBLE FREQUENCY 22 mm

This coil can be mounted with every Parker ATEX solenoid valves corresponding to the specified Coil Group.

See column "Coil Group" within valve pages.

**Application:**

Control of solenoid valves in dangerous areas where explosion-proof protection Ex nAc nCc IIC T5 is required.

**Benefits:**

The synthetic material encapsulation of the coil provides an effective compact housing, offering full protection against dust, oil, water, etc. Small size for ease of mounting in confined spaces.



Specification		Double Frequency			
Reference		496637			
Certificate		ATEX			
Coil group		1.2			
Type of protection	Gas	Ex nAc nCc IIC T5			
	Dust	II 3 D - Ex tc IIC - T 95°C			
Degree of protection		IP65 (with plug) according to IEC/EN 60529 Standards			
Ambiant temperature		-20°C to +50°C The application is limited also by the temperature range of the valve.			
Insulation Class		F 155°C			
Elect. Power	DC	Pn (hot)	3 W		
		P (cold) 20°C	-		
AC	Pn (holding)	3 W			
	Attraction cold	5.7 VA (2.5 W)			
Weight		75 g			
Voltages "Un"		VAC/Hz	Code	VDC	Code
-10% to +10% of the Un		24/50-60	P0	24 V	C2
		110/50-60	P2	48 V	C4
		230/50-60	P9	110 V	C5
		48/50-60	S4		

**To Order a Coil choose** Coil Ref + Voltage Code, example: 496637 for 24 VDC = **496637C2**

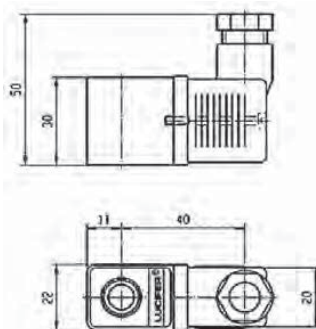

**EXPLOSION PROOF  
ELECTRICAL PARTS**

**COIL GROUP**

**2.0/2.1 ELECTRICAL PARTS  
"nAc nCc"**



**ZONE 2/22**

**ELECTRICAL PART 32 mm**

These coils can be mounted with every Parker ATEX solenoid valves corresponding to the specified Coil Group.  
See column "Coil Group" within valve pages.

**Application:** Control of solenoid valves in dangerous areas where explosion-proof protection Ex nAc nCc IIC T3/T4 is required.  
Ease of mounting in confined space - offers shock and corrosion protection-simplifies conversion of existing equipment to other requirements, etc.

**Benefits:**

The synthetic material encapsulation of the coil provides an effective compact housing, offering full protection against dust, oil, water, etc.  
Small size for ease of mounting in confined spaces.



<b>Reference</b>		<b>495870</b>			<b>496110</b>		
<b>Certificate</b>		<b>LCIE 05 ATEX 6003 X</b>					
<b>Coil Group</b>		<b>2.0 / 2.1</b>					
<b>Type of protection</b>	<b>Gas</b>	II 3 G Ex nAc nCc IIC T3/T4			II 3 G Ex nAc nCc IIC T3/T4		
	<b>Dust</b>	II 3 D - Ex tc IIIC - T195°C / T130°C			II 3 D - Ex tc IIIC - T195°C / T130°C		
<b>Degree of protection</b>		<b>IP65 (with plug) according to IEC/EN 60529 Standards</b>					
<b>Insulation Class</b>		F (155°C)					
<b>Duty cycle</b>		100%					
<b>Ambiant temperature</b>		-40°C to +65°C / 50°C The application is limited also by the temperature range of the valve.					
<b>Elect. Power</b>	<b>DC</b>	<b>Pn (hot)</b>	9 W			-	
		<b>P (cold) 20°C</b>	12 W			-	
	<b>AC</b>	<b>Pn (holding)</b>	8 W			9 W	
		<b>Attraction cold</b>	26 VA (9 W)			32 VA (10 W)	
<b>Weight</b>		150 g					
<b>Voltages "Un"</b>		<b>VAC/Hz</b>	<b>Code</b>	<b>VDC</b>	<b>Code</b>	<b>VAC/Hz</b>	<b>Code</b>
-10% to +10% of the Un		24/50	A2	24	C2	24/50-60	P0
		48/50	A4	48	C4	48/50-60	S4
		110/50	A5	110	C5	110/50-60	S5
		220-230/50	3D			220/50-60	S6

**To Order a Coil choose** Coil Ref + Voltage Code, example: 495870 for 24 VDC = **495870C2**

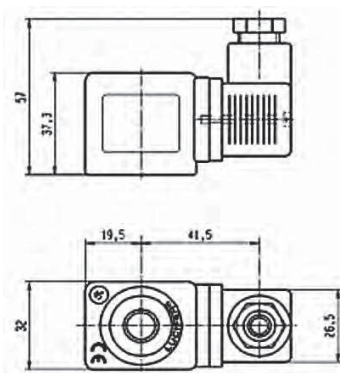

**COIL GROUP**
**6.0**
**ELECTRICAL PARTS  
"nAc nCc"**

**ZONE 2/22**
**ELECTRICAL PART LOW POWER 32 mm**

This coil can be mounted with every Parker ATEX solenoid valves corresponding to the specified Coil Group.  
See column "Coil Group" within valve pages.

**Application:** Control of solenoid valves in dangerous areas where explosion-proof protection Ex nAc nCc IIC T5/T6 is required.  
Ease of mounting in confined space - offers shock and corrosion protection-simplifies conversion of existing equipment to other requirements, etc.

**Benefits:**

The synthetic material encapsulation of the coil provides an effective compact housing, offering full protection against dust, oil, water, etc.  
Small size for ease of mounting in confined spaces.



<b>Reference</b>		<b>496125</b>	
<b>Certificate</b>		<b>LCIE 05 ATEX 6003 X</b>	
<b>Coil group</b>		<b>6.0</b>	
<b>Type of protection</b>	<b>Gas</b>	II 3 G Ex nAc nCc IIC T5/T6	
	<b>Dust</b>	II 3 D Ex tc IIIC T95°C/80°C	
<b>Degree of protection</b>		<b>IP65</b> (with plug) according to IEC/EN 60529 Standards	
<b>Insulation Class</b>		F (155°C)	
<b>Duty cycle</b>		100%	
<b>Ambiant temperature</b>		-40°C to +65°C / 50°C The application is limited also by the temperature range of the valve.	
<b>Elect. Power</b>	<b>DC</b>	<b>Pn (hot)</b>	1.6 W
		<b>P (cold) 20°C</b>	2.1 W
	<b>AC</b>	<b>Pn (holding)</b>	-
		<b>Attraction cold</b>	-
<b>Weight</b>		150 g	
<b>Voltages "Un"</b>		<b>VDC</b>	<b>Code</b>
-10% to +10% of the Un		24	C2
		48	C4
		110	C5

**To Order a Coil choose** Coil Ref + Voltage Code, example: 496125 for 24 VDC = **496125C2**

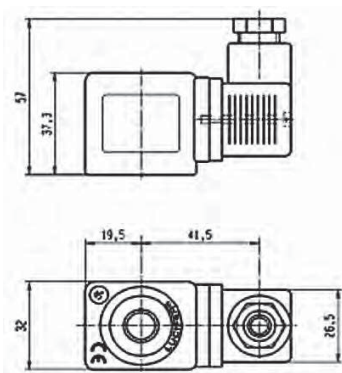

**EXPLOSION PROOF  
ELECTRICAL PARTS**

**COIL GROUP**

**3.0**

**ELECTRICAL PARTS  
"nAc nCc"**



**ZONE 2/22**

**ELECTRICAL PART 32 mm**

This coil can be mounted with every Parker ATEX solenoid valves corresponding to the specified Coil Group.  
See column "Coil Group" within valve pages.

**Application:** Control of solenoid valves in dangerous areas where explosion-proof protection Ex nAc nCc IIC T3/T4 is required.  
Ease of mounting in confined space - offers shock and corrosion protection-simplifies conversion of existing equipment to other requirements, etc.

**Benefits:**

The synthetic material encapsulation of the coil provides an effective compact housing, offering full protection against dust, oil, water, etc.  
Small size for ease of mounting in confined spaces.



Specification		32 mm Coil "nAc nCc"			
Reference		495875			
Certificate		LCIE 05 ATEX 6003 X			
Coil Group		3.0			
Type of protection	Gas	II 3 G Ex nAc nCc IIC T3/T4			
	Dust	II 3 D - Ex tc IIC - T195°C / T130°C			
Degree of protection		IP65 (with plug) according to IEC/EN 60529 Standards			
Insulation Class		F 155°C			
Duty cycle		100%			
Ambiant temperature		-40°C to +65°C / 50°C The application is limited also by the temperature range of the valve.			
Elect. Power	DC	Pn (hot)	7 W		
		P (cold) 20°C	-		
	AC	Pn (holding)	6 W		
		Attraction cold	-		
Weight		180 g			
Voltages "Un"		VAC/Hz	Code	VDC	Code
-10% to +10% of the Un		220-230/50	3D	24	C2

To Order a Coil choose Coil Ref + Voltage Code, example: 495875 for 24 VDC = 495875C2

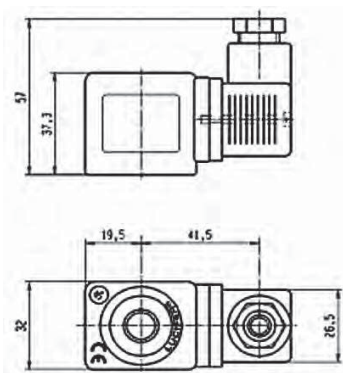

**COIL GROUP**
**2.0/2.2**
**NON ENCAPSULATED  
ELECTRICAL PARTS  
"nAc nCc"**

**ZONE 2/22**

## ELECTRICAL PART 32 mm

This coil can be mounted with every Parker ATEX solenoid valves corresponding to the specified Coil Group.  
See column "Coil Group" within valve pages.

**Application:** Control of solenoid valves in dangerous areas where explosion-proof protection Ex nAc nCc IIC T3 is required.  
Ease of mounting in confined space - offers shock and corrosion protection - simplifies conversion of existing equipment to other requirements, etc.

**Benefits:**

The synthetic material encapsulation of the coil provides an effective compact housing, offering full protection against dust, oil, water, etc.  
Small size for ease of mounting in confined spaces.



Specification		32 mm Coil "nAc nCc"			
Reference		495880			
Certificate		LCIE 05 ATEX 6003X			
Coil Group		2.0 / 2.2			
Type of protection	Gas	II 3 G Ex nAc nCc IIC T3			
	Dust	II 3 D - Ex tc IIC - T195°C			
Degree of protection		IP65 (with plug) according to IEC/EN 60529 Standards			
Insulation Class		H 180°C			
Duty cycle		100%			
Ambiant temperature		-40°C to +65°C The application is limited also by the temperature range of the valve.			
Elect. Power	DC	Pn (hot)	14 W		
		P (cold) 20°C	-		
	AC	Pn (holding)	14 W		
		Attraction cold	-		
Weight		180 g			
Voltages "Un"		VAC/Hz	Code	VDC	Code
-10% to +10% of the Un		24/50	A2	24	C2
		110/50	A5		
		230/50	F4		

To Order a Coil choose Coil Ref + Voltage Code, example: 495880 for 24 VDC = 495880C2

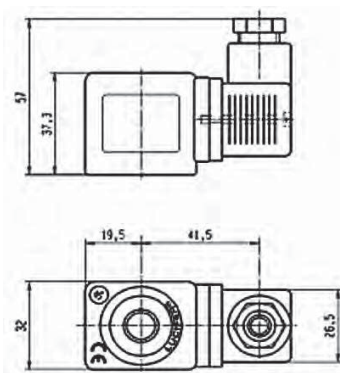

**EXPLOSION PROOF  
ELECTRICAL PARTS**

COIL GROUP

**4.0**

**INCREASED SAFETY  
ELECTRICAL PARTS  
"nAc nCc"**



**ZONE 2/22**

**495915 - ELECTRICAL PARTS 50 mm**

This coil can be mounted with every Parker ATEX solenoid valves corresponding to the specified Coil Group.  
See column "Coil Group" within valve pages.

**Application:** Control of solenoid valves in dangerous areas where explosion-proof protection - Ex nAc nCc IIC T3 is required.

**Benefits:** Rotatable housing 360°, epoxy varnished steel with internal and external screw terminals for earth connection.

Small size for ease of mounting in confined space. Simplifies conversion of existing equipment to hazardous area requirements.



<b>Reference</b>		<b>495915</b>			
<b>Certificate</b>		<b>LCIE 05 ATEX 6010 X</b>			
<b>Coil group</b>		<b>4.0</b>			
<b>Type of protection</b>	<b>Gas</b>	II 3 G Ex nAc nCc IIC T3			
	<b>Dust</b>	II 3 D - Ex tc IIC - T 195°C			
<b>Degree of protection</b>		<b>IP67</b> according to IEC/EN 60529 Standards			
<b>Ambient temperature</b>		-40°C to +65°C The application is limited also by the temperature range of the valve.			
<b>Insulation Class</b>		F 155°C			
<b>Electrical connection</b>		By special cable gland M20 x 1.5 on screw terminals for wires up to 1.5 mm <sup>2</sup> . Cable with outside diameter 6.5 mm to 13.5 mm can be simply sealed using the rubber gland with resilient sealing rings supplied			
<b>Consumption Electrique</b>	<b>AC</b>	Attraction (hot)	11 W	-	
		Attraction (cold) 20°C	17 W	-	
		Release (hot)	4 W	-	
		Release (cold) 20°C	7 W	-	
	<b>DC</b>	Attraction (hot)	-	13 W	
		Attraction (cold) 20°C	-	19 W	
		Release (hot)	-	8 W	
		Release (cold) 20°C	-	10 W	
<b>Weight</b>		320 g			
<b>Duty cycle</b>		Continuous duty solenoid (ED 100%)			
<b>Voltages "Un"</b>		<b>VAC/Hz</b>	<b>Code</b>	<b>VDC</b>	<b>Code</b>
-10% to +10% of the Un		110-115/50-60	1P	24	C2
		220-230/50-60	3P	48	C4
		48/50-60	S4		
		24/50-60	P0		

**To Order a Coil choose Coil Ref + Voltage Code,**  
example: 495915 for 24 VDC = **495915C2**

**Schema**

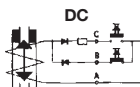
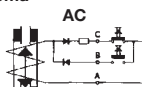

As soon as an electrical impulse is given to the terminals A-B, the electromagnetical force attracts the plunger and simultaneously magnetizes a reversible permanent magnet ring. This magnet retains the plunger in place. It stays in position even without current. Only an electrical impulse given to terminals A-C reserves the magnetic field. This magnetic field demagnetises the reversible magnet enough to allow the return spring to bring the plunger back to its initial position and close the valve.

**Switch:** Switch on (terminals A-B): Minimum 50 ms (maximum 1 s)  
AC: Switch off (terminals A-C): Minimum 35 ms (maximum 1 s)

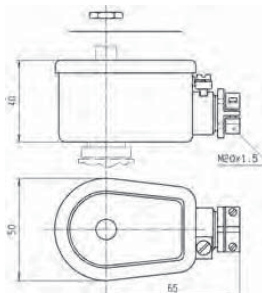

**COIL GROUP**
**2.0/2.2**
**INCREASED SAFETY  
ELECTRICAL PARTS  
"nAc nCc"**

**ZONE 2/22**

### 3.5.1 ELECTRICAL PARTS 496155

These coils can be mounted with every Parker solenoid valves corresponding to the specified Coil Group.

See column "Coil Compatibility Group" within valve pages.

**Application:** Control of solenoid valves in dangerous areas where explosion-proof protection Ex nAc nCc IIC T3 is required.

**Benefits:** Rotatable housing 360°, epoxy varnished steel with internal and external screw terminals for earth connection.

Small size for ease of mounting in confined space. Simplifies conversion of existing equipment to hazardous area requirements.



<b>Reference</b>		<b>496155</b>			
<b>Certificate</b>		<b>LCIE 05 ATEX 6010 X</b>			
<b>Coil Group</b>		<b>2.0/2.2</b>			
<b>Type of protection</b>	<b>Gas</b>	II 3 G Ex nAc nCc IIC T3			
	<b>Dust</b>	II 3 G D - Ex tc IIIC - T 195 °C			
<b>Degree of protection</b>		<b>IP67</b> according to IEC/EN 60529 Standards			
<b>Ambiant temperature</b>		-40°C to +65°C The application is limited also by the temperature range of the valve.			
<b>Insulation Class</b>		F 155°C			
<b>Electrical connection</b>		By special cable gland or M20x1.5 on screw terminals for wires up to 1.5 mm <sup>2</sup> . Cables with outside diameter 6.5 mm to 13.5 mm can be simply sealed using the rubber gland with resilient sealing rings supplied.			
<b>Elect. Power</b>	<b>DC</b>	Pn (hot)	14 W		
		P (cold) 20°C	21 W		
	<b>AC</b>	Pn (holding)	14 W		
		Attraction cold	56 VA (20 W)		
<b>Weight</b>		320 g			
<b>Voltages "Un"</b>		<b>VAC/Hz</b>	<b>Code</b>	<b>VDC</b>	<b>Code</b>
-10% to +10% of the Un		24/50	A2	24	C2
		110/50	A5	48	C4
		230/50	F4		

**To Order a Coil choose** Coil Ref + Voltage Code, example: 496155 for 24VAC/50Hz = **496155A2**

**Fuses:**

Both electrical parts have to be connected in series with a safety fuse according to IEC 60127-3.

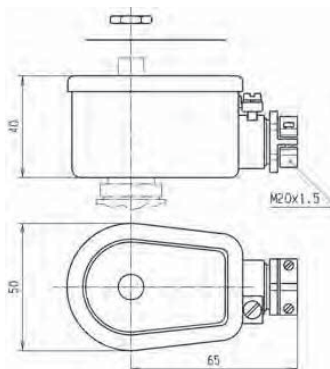

**EXPLOSION PROOF  
ELECTRICAL PARTS**

COIL GROUP

**11.0**

**FLAME PROOF  
ELECTRICAL PARTS  
"db"**



**ZONE 1/21**

**483270 & 483270.02 - ELECTRICAL PARTS 50 mm**

These coils can be mounted with every Parker ATEX solenoid valves corresponding to the specified Coil Group.  
See column "Coil Group" within valve pages.

**Application:** Control of solenoid valves in dangerous areas where explosion-proof protection Ex db IIC T4 to T6 is required.

**Benefits:** Rotatable 360°, housing made of cast iron with internal connection chamber: Cover made of aluminium alloy fixed with 4 screws. The electromagnetic control pilot is composed of three main elements: housing, coil and plunger tube including housing plate.

Small size for ease of mounting in confined space.



<b>Reference</b>		483270 (M20 x 1.5) 483270.02 (1/2 NPT)			
<b>Certificate</b>		LCIE 02 ATEX 6008 X			
<b>Coil group</b>		11.0			
<b>Type of protection</b>	Gas	II 2 G - Ex db IIC T4/T5/T6			
	Dust	II 2 D - Ex tb IIIC - T130°C/ 95°C/ 80°C			
<b>Degree of protection</b>		IP66 with appropriate cable gland according to IEC/EN 60529 Standards			
<b>Ambient temperature</b>		-40 to +80°C / +75°C / +60°C The application is limited also by the temperature range of the valve.			
<b>Class of insulation</b>		F (155 °)			
<b>Electrical connection</b>		The electrical connection is made within the housing connection chamber on an accessible screw terminal. The cable entry to the connecting chamber is made through 1/2" NPT thread suitable for fitting an approved Ex db IIC cable gland.			
<b>Elect. Power</b>	<b>DC</b>	Pn (hot)	8 W		
		P (cold) 20°C	9 W		
	<b>AC</b>	Pn (holding)	8 W		
		Attraction cold	9 W		
<b>Weight</b>		1100 g (with coil)			
<b>Voltages "Un"</b>		<b>VAC/Hz</b>	<b>Code</b>	<b>VDC</b>	<b>Code</b>
-10% to +10% of the Un		110-115/50-60	1P	24	C2
		220-230/50-60	3P	48	C4
				110	C5

**To Order a Coil choose Coil Ref + Voltage Code, example: 483270 for 24 VDC = 483270C2**

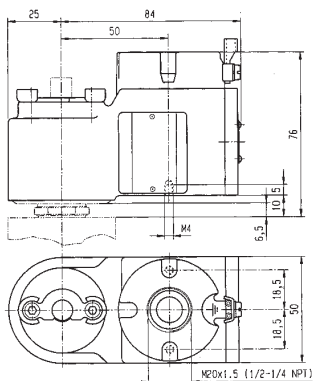

**Plunger tube:**

The plunger tube is welded to the stainless steel plate and is thus integrated to the housing which is screwed on the valve body.  
This electrical part is supplied only as complete unit mounted on a valve, as the "Ex db" protection depends on minimum gap between plunger tube, plate and housing.

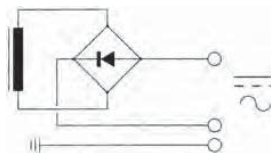

**COIL GROUP**
**10.3**
**FLAMEPROOF  
ELECTRICAL PARTS  
"db"**

**ZONE 1/21**

## 497105 & 497105.02 - ELECTRICAL PARTS

These coils can be mounted with every Parker ATEX solenoid valves corresponding to the specified Coil Group.  
See column "Coil Group" within valve pages.

**Application:** Control of solenoid valves in dangerous areas where explosion-proof protection Ex db IIC T4 / T5 / T6 is required.

**Benefits:** Rotatable 360°, stainless steel with internal and external screw terminals for earth connection.

Small size for ease of mounting in confined space. Simplifies conversion of existing equipment to hazardous area requirements.



<b>Reference</b>		<b>497105 (M20x1.5) 497105.02 (NPT 1/2")</b>		
<b>Certificate</b>		<b>INERIS 12ATEX0041X - IECEx INE 12.0034X</b>		
<b>Coil Group</b>		<b>10.3</b>		
<b>Type of protection</b>	<b>Gas</b>	II 2 G - Ex db IIC T4 / T5 / T6		
	<b>Dust</b>	II 2 D - Ex tb IIIC - 130°C / 95°C / 80°C		
<b>Degree of protection</b>		<b>IP66</b> (with relevant cable gland) according to IEC/EN 60529 Standards		
<b>Ambient temperature</b>		-50°C to +80°C / +60°C / +40°C The operating temperature of the valve/coil can be limited by that of the valve		
<b>Insulation Class</b>		F 155°C		
<b>Electrical connection</b>		Electric connection is done in the connection chamber on an easily accessible connector terminals. The cable entry to the connection chamber is made through a 1/2" NPT or M20x1.5 thread in which an approved Exdb IIC cable gland must be installed.		
<b>Electrical consumption</b>	<b>DC</b>	<b>Pn (hot)</b>	8 W	
		<b>P (cold) 20°C</b>	9 W	
	<b>AC</b>	<b>Pn (holding)</b>	8 W	
		<b>Attraction cold</b>	9 W	
<b>Voltage Tolerance</b>		+/- 10% of nominal voltage		
<b>Emergising Cuty</b>		ED 100%		
<b>Voltages</b>	<b>VAC/Hz</b>	<b>Code</b>	<b>VDC</b>	<b>Code</b>
	24/50-60	P0	12	C1
	110-115 / 50-60	1P	24	C2
	220-230 / 50-60	3P	48 110	C4 C5

**To Order a Coil choose** Coil Ref + Voltage Code, example: 497105 for 24 VDC = **497105C2**

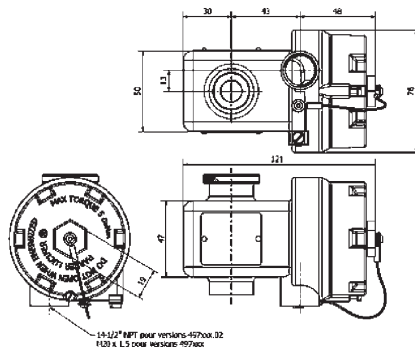

**EXPLOSION PROOF  
ELECTRICAL PARTS**

**COIL GROUP**

**1.1**

**ENCAPSULATED  
ELECTRICAL PARTS  
"mb"**



**ZONE 1/21**

**ELECTRICAL PART LOW POWER 22 mm**

These coils can be mounted with every Parker ATEX solenoid valves corresponding to the specified Coil Group. See column "Coil Group" within valve pages.

**Application:**

Control of solenoid valves in dangerous areas where explosion-proof protection Ex mb IIC T4 / T5 is required.

**Benefits:**

Coil and magnetic circuit encapsulated in synthetic material - offering shock and corrosion protection. AC coils with integrated thermal fuse. Small size for ease of mounting in confined spaces.



<b>Reference</b>	<b>482605</b>		<b>482606 or 482606.160*</b>				
<b>Certificate</b>	<b>LCIE 02 ATEX 6014 X - IECEx LCI 07.0026 X</b>						
<b>Coil Group</b>	<b>1.1</b>						
<b>Type of protection</b>	<b>Gas</b>	II 2 G - Ex mb IIC T4 / T5					
	<b>Dust</b>	II 2 D - Ex tb IIC - T130°C / 95°C					
<b>Degree of protection</b>	<b>IP65</b> (with plug) according to IEC/EN 60529 Standards						
<b>Ambiant temperature</b>	-40°C to +65°C / +40°C			-40°C to +65°C / +35°C			
	The application is limited also by the temperature range of the valve.						
<b>Insulation Class</b>	F 155°C						
<b>Electrical connection</b>	Cable connection (3 x 0.75 mm <sup>2</sup> ) encapsulated with coil, cable material according to application						
<b>Elect. Power</b>	<b>DC</b>	<b>Pn (hot)</b>	5 W	2.5 W			
		<b>P (cold) 20°C</b>	6.5 W	3 W			
	<b>AC</b>	<b>Pn (holding)</b>	4 W	2 W			
		<b>Attraction cold</b>	8.9 VA (5 W)	5.7 VA (2.5 W)			
<b>Weight</b>	150 g						
<b>Voltages "Un"</b>	<b>VDC</b>	<b>Code</b>	<b>VAC/Hz</b>	<b>Code</b>	<b>VDC</b>	<b>Code</b>	
-10% to +10% of the Un	12	C1	24/50	A2	24	C2	
	24	C2	48/50	A4	48	C4	
			110/50-115/50	0A	110	C5	
			220/50-230/50	3D			

**To Order a Coil choose** Coil Ref + Voltage Code, example: 482605 for 24 VDC = **482605C2**

\* 482606.160 - 6 m cable length - available only in C2 and C3

\* 482606 - 1.5 m cable length

**Fuses:**

Both electrical parts 482605 & 482606 have to be connected in series with a safety fuse according to CEI 60127-3. Indicating example below:

**482605:**

- DC: 12 V, 1000 mA - 24 V, 500 mA - 48 V, 200 mA - 110 V, 100 mA
- AC 50 Hz: 24 V, 500 mA - 48 V, 250 mA - 110/115 V, 100 mA - 220/230 V, 3 mA
- AC 60 Hz: 24 V, 630 mA - 110/115 V, 125 mA - 220/230 V, 63 mA

**482606:**

- DC: 12 V, 400 mA - 24 V, 200 mA - 48 V, 100 mA - 110 V, 50 mA
- AC 50 Hz: 24 V, 250 mA - 48 V, 125 mA - 110/115 V, 63 mA - 220/230 V, 32 mA
- AC 60 Hz: 24 V, 315 mA - 110/115 V, 63 mA - 220/230 V, 32 mA

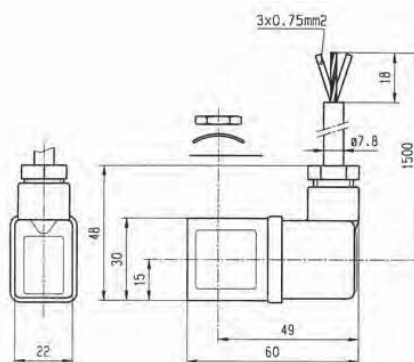

**COIL GROUP**
**2.0/2.1**
**ENCAPSULATED  
ELECTRICAL PARTS  
"mb"**

## ELECTRICAL PART 32 mm

This coil can be mounted with every Parker ATEX solenoid valves corresponding to the specified Coil Group.  
See column "Coil Group" within valve pages.

**Application:** Control of solenoid valves in dangerous areas where explosion-proof protection Ex mb IIC T4 is required.

**Benefits:** Coil and magnetic circuit encapsulated in synthetic material offering shock and corrosion protection. AC/DC coils with integrated thermal fuse. DC coils with integrated surge suppression diode.

Small size for ease of mounting in confined spaces. This electrical

**ZONE 1/21**

<b>Reference</b>		<b>492670*</b>			
<b>Certificate</b>		<b>LCIE 02 ATEX 6015 X</b>			
<b>Coil Group</b>		<b>2.0 / 2.1</b>			
<b>Type of protection</b>	<b>Gas</b>	II 2 G - Ex mb IIC T4			
	<b>Dust</b>	II 2 D - Ex tb IIIC - T130°C			
<b>Degree of protection</b>		<b>IP65</b> (With DIN Plug connector) according to IEC/EN 60529 standards			
<b>Ambiant temperature</b>		-40°C to +40°C The application is limited also by the temperature range of the valve.			
<b>Class of insulation</b>		F 155°C			
<b>Electrical connection</b>		Cable connection (3 x 1.5 mm <sup>2</sup> ) encapsulated with coil, cable material according to application			
<b>Elect. Power</b>	<b>DC</b>	Pn (hot)	9 W		
		P (cold) 20°C	12 W		
	<b>AC</b>	Pn (holding)	8 W		
		Attraction cold	26 VA (9 W)		
<b>Weight</b>		320 g			
<b>Voltages "Un"</b>		<b>VAC/Hz</b>	<b>Code</b>	<b>VDC</b>	<b>Code</b>
-10% to +10% of the Un		48/50	A4	24	C2
		230/50	F4	48	C4
				110	C5

**To Order a Coil choose** Coil Ref + Voltage Code, example: 492670 for 24 VDC = **492670C2**

\* 492670 3 m cable length

### Special conditions:

The supply connection lines have to be fixed and positioned in such a way that they are protected against mechanical damages.

It is necessary to use a safety fuse with a nominal current corresponding to the coil current (max. 3 x nominal according to IEC 60127 and IEC 60269) against short-circuits.

### Recommended values:

DC: 12 V, 1250 mA - 24 V, 630 mA - 48 V, 315 mA - 110 V, 125 mA  
AC 50 Hz: 24 V, 1000 mA - 48 V, 500 mA - 110 V, 250 mA - 230 V, 100 mA  
AC 60 Hz: 240 V, 100 mA

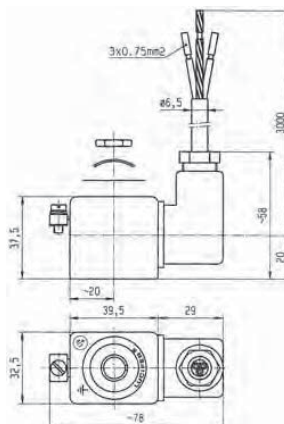

**EXPLOSION PROOF  
ELECTRICAL PARTS**

COIL GROUP

**2.0/2.1**

**ENCAPSULATED  
ELECTRICAL PARTS  
"mb"**



**ZONE 1/21**

**WITH WATER PROOF METAL HOUSING 50 mm**

These coils can be mounted with every Parker ATEX solenoid valves corresponding to the specified Coil Group. See column "Coil Group" within valve pages.

**Application:** Control of solenoid valves in dangerous areas where explosion-proof protection Ex mb IIC T4/ T5 is required.

**Benefits:** Epoxy-vernished steel housing - solenoid coil, rectifier (silicium diodes), fuse and varistor protection element are completely encapsulated in the coil housing by means of epoxy resin.

Small size for ease of mounting in confined space. Simplifies conversion of existing equipment to hazardous area requirements.



Reference	492070 ( with 3 m cable length ) 492070.160 ( with 6 m cable length )			
Certificate	LCIE 02 ATEX 6017 X - IECEx LCI 09.0024 X			
Coil Group	2.0 / 2.1			
Type of protection	Gas	II 2 G - Ex mb IIC T4/ T5		
	Dust	II 2 D - Ex tb IIIC - T130 / 95°C		
Degree of protection	IP67 according to IEC/EN 60529 standards			
Ambient temperature	-40°C to +65°C / 40°C The application is limited also by the temperature range of the valve.			
Insulation Class	F 155°C			
Electrical connection	Cable connection (3 x 1.5 mm <sup>2</sup> ) with cable gland M20 x 1.5, external earth screw connection.			
Elect. Power	DC	Pn (hot)	8 W	
		P (cold) 20°C	10 W	
	AC	Pn (holding)	9 W	
		Attraction cold	11 W	
Weight	500 g			
Voltages "Un" -10% to +10% of the Un	VAC/Hz	Code	VDC	Code
	24/50-60	P0	24	C2
	110/50-60	P2	48	C4
	220/50-60	R5	110	C5
	230/50-60	P9		
	240/50-60	Q1		

To Order a Coil choose Coil Ref + Voltage Code, example: 492070 for 24 VDC = 492070C2

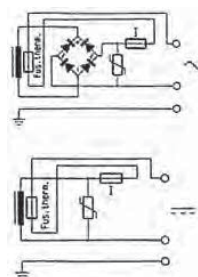
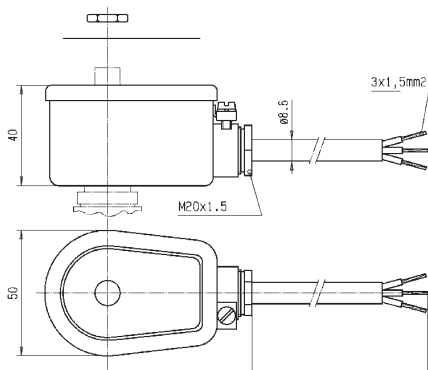

**COIL GROUP**
**2.0/2.1**
**ENCAPSULATED  
ELECTRICAL PARTS  
"mb"**

**ZONE 1/21**

## HZ10 COIL DOUBLE FREQUENCY

This coil can be mounted with every Parker ATEX solenoid valves corresponding to the specified Coil Group.  
See column "Coil Group" within valve pages.

**Application:** Control of solenoid valves in dangerous areas where explosion-proof protection Ex mb IIC T3/T4/T5 is required.

The coil is delivered with a 3m cable.



Specification		Double Frequency			
Reference		<b>HZ10</b>			
Certificate		<b>LCIE 02 ATEX 6020 X - IECEx LCI 08.0027 X</b>			
Coil Group		<b>2.0 / 2.1</b>			
Type of protection	Gas	II 2 G - Ex mb IIC T3/T4/T5			
	Dust	II 2 D - Ex tb III C T195°C / 130°C / 95°C			
Degree of protection		<b>IP65</b> (with plug) according to IEC/EN 60529 Standards			
Ambient temperature		-40°C to +80°C / 65°C / 40°C The application is limited also by the temperature range of the valve.			
Insulation Class		H 180°C			
Duty cycle		100% continuous			
Electrical connection		Cable connection (3 x 1.5 mm <sup>2</sup> ) with cable gland M20 x 1.5, external earth screw connection.			
Elect. Power	DC	Pn (hot)	8 W		
		P (cold) 20°C	-		
	AC	Pn (holding)	8 W		
		Attraction cold	-		
Weight		299 g			
Voltages "Un"		<b>VAC/Hz</b>	<b>Code</b>	<b>VDC</b>	<b>Code</b>
-10% to +10% of the Un		24/60	B2	12	C1
		110/50-120/60	P3	24	C2
		220/50-240/60	Q3	120	C6

**To Order a Coil choose Coil Ref + Voltage Code, example: HZ10 for 24 VDC = HZ10C2**

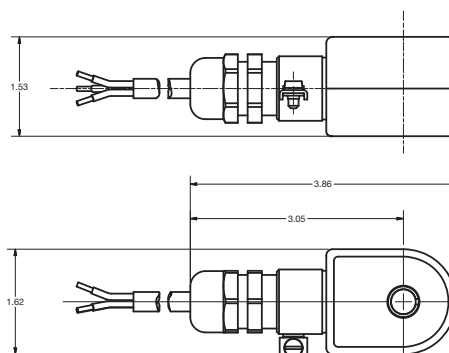

Dimensions in Inches.



**EXPLOSION PROOF  
ELECTRICAL PARTS**

**COIL GROUP  
2.0/2.2**

**ENCAPSULATED  
ELECTRICAL PARTS  
"mb"**



**ZONE 1/21**

**HZ11 COIL DOUBLE FREQUENCY**

This coil can be mounted with every Parker ATEX solenoid valves corresponding to the specified Coil Group.

See column "Coil Group" within valve pages.

**Application:** Control of solenoid valves in dangerous areas where explosion-proof protection Ex mb IIC T3/T4/T5 is required.

The coil is delivered with a 3m cable.



Specification		Double Frequency			
Reference		HZ11			
Certificate		LCIE 02 ATEX 6020 X - IECEx LCI 08.0027 X			
Coil Group		2.0 / 2.2			
Type of protection	Gas	II 2 G - Ex mb IIC T3/T4/T5			
	Dust	II 2 D - Ex tb III C T195°C / 130°C / 95°C			
Degree of protection		IP65 (with plug) according to IEC/EN 60529 Standards			
Ambient temperature		-40°C to + 65°C / 40°C The application is limited also by the temperature range of the valve..			
Insulation Class		H 180 °C			
Duty cycle		100% continuous			
Elect. Power	DC	Pn (hot)	14 W		
		P (cold) 20°C	-		
	AC	Pn (holding)	14 W		
		Attraction cold	-		
Weight		299 g			
Voltages "Un"		VAC/Hz	Code	VDC	Code
-10% to +10% of the Un		24/60	B2	12	C1
		110/50-120/60	P3	24	C2
		220/50-240/60	Q3	120	C6

To Order a Coil: Coil Ref + Voltage Code, example: HZ11 for 24 VDC = HZ11C2

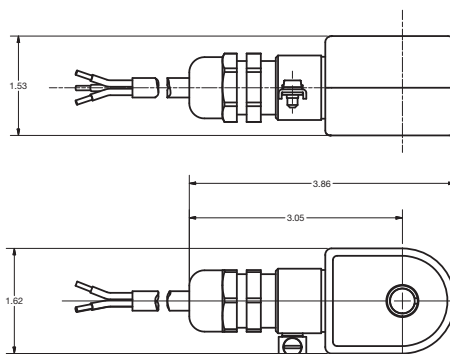

Dimensions in Inches.



**COIL GROUPS**
**6.0**
**FLAME PROOF ENCAPSULATED  
ELECTRICAL PARTS  
"db mb"**

**495900 - LOW POWER ELECTRICAL PARTS 37 mm**

This coil can be mounted with every Parker ATEX solenoid valves corresponding to the specified Coil Group.  
See column "Coil Group" within valve pages.

**Application:** Control of solenoid valves in dangerous areas where explosion-proof protection Ex db mb IIC T4 to T6 is required.

**Benefits:** Rotatable 360° fibreglass-reinforced plastic housing (class H). Solenoid coil, rectifier (silicium diodes), fuses and varistor protection are completely encapsulated into the coil housing by epoxy resin for shock and corrosion protection.

The plastic housing is delivered with M20 x 1.5 cable gland certified for use "db" protection. Small size for ease of mounting in confined space.

**ZONE 1/21**

Reference	495900 (VAC)		495900 (VDC)		
Certificate	LCIE 03 ATEX 6451 X - IECEx LCI 06.0004 X				
Coil Group	6.0				
Type of protection	Gas	II 2 G - Ex db mb IIC T4 / T5 / T6	II 2 G - Ex db mb IIC T4 / T5 / T6		
	Dust	II 2 D Ex tb IIIC - 130°C / 95°C / 80°C	II 2 D Ex tb IIIC - T130°C / 95°C / 80°C		
Degree of protection	IP67 according to IEC/EN 60529 Standards				
Ambient temperature	-40°C to +80°C / 55°C / 40°C		-40°C to +80°C / 65°C / 55°C		
	The application is limited also by the temperature range of the valve.				
Class of insulation	H (180 °)				
Electrical connection	Electric connection is done in the connection box on an easily accessible connector terminals. The introduction of the cable (Ø min 5 mm, Ømax. 11 mm, section max. 2.5 mm <sup>2</sup> ) in the connection box passes by the built in M20 x 1.5 cable gland				
Elect. Power	DC	Pn (hot)	-	2 W	
		P (cold) 20°C	-	2.5 W	
	AC	Pn (holding)	2.5 W	-	
		Attraction cold	3 W	-	
Voltages "Un"		VAC/Hz	Code	VDC	Code
-10% to +10% of Un for AC		24/50	A2	24	C2
-10 % to + 10 % for Un DC.		48/50	A4	48	C4
		115/50	E5	110	C5
		230/50	F4		

**To Order a Coil:** Coil Ref + Voltage Code, example: 495900 for 24 VDC = **495900C2**

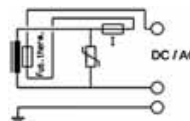
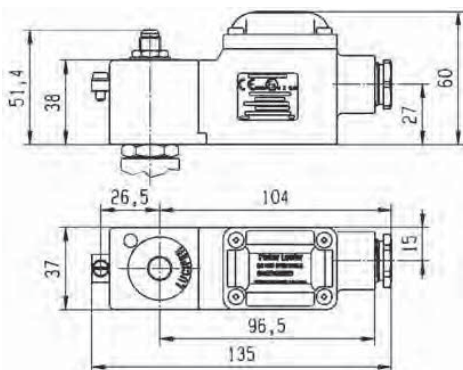

**EXPLOSION PROOF  
ELECTRICAL PARTS**

**COIL GROUPS**

**2.0/2.1**

**FLAME PROOF ENCAPSULATED  
ELECTRICAL PARTS  
"db mb"**



**ZONE 1/21**

**495905 - ELECTRICAL PARTS 37 mm**

These coils can be mounted with every Parker ATEX solenoid valves corresponding to the specified Coil Group.  
See column "Coil Group" within valve pages.

**Application:** Control of solenoid valves in dangerous areas where explosion-proof protection Ex db mb IIC T4 is required.

**Benefits:** Rotatable 360° fibreglass-reinforced plastic housing (class H). Solenoid coil, rectifier (silicium diodes), fuses and varistor protection are completely encapsulated into the coil housing by epoxy resin for shock and corrosion protection.

The plastic housing is delivered with M20 x 1.5 cable gland certified for use "db" protection. Small size for ease of mounting in confined space.



Reference	495905		495905.05*	
Certificate	LCIE 03 ATEX 6451 X - IECEx LCI 06.0004 X			
Coil Group	2.0 / 2.1			
Type of protection	Gas	II 2 G - Ex db mb IIC T4		
	Dust	II 2 D - Ex tb IIC - 130°C		
Degree of protection	IP67 according to IEC/EN 60529 Standards			
Ambient temperature	-40°C to +80°C The application is limited also by the temperature range of the valve.			
Class of insulation	H (180 °)			
Electrical connection	Electric connection is done in the connection box on an easily accessible connector terminals. The introduction of the cable (Ø min 5 mm, Ømax. 11 mm, section max. 2.5 mm²) in the connection box passes by the built in M20 x 1.5 cable gland.			
Elect. Power	DC	Pn (hot)	8 W	
		P (cold) 20°C	9 W	
	AC	Pn (holding)	8 W	
		Attraction cold	9 W	
Voltages "Un"	VAC/Hz	Code	VDC	Code
-10% to +10% of Un for AC	24/50	A2	24	C2
-10% to +10% for Un DC	48/50	A4	48	C4
	115/50	E5	110	C5
	230/50	F4		

**To Order a Coil choose** Coil Ref + Voltage Code, example: 495905 for 24 VDC = **495905C2**

\* 495905.05 available only in C4

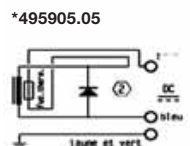
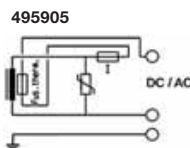
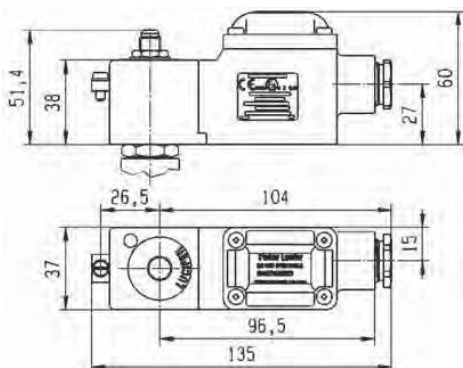

**COIL GROUP**  
**10.2/10.1**
**FLAME PROOF ENCAPSULATED  
ELECTRICAL PARTS**  
**"db mb"**

**ZONE 1/21**
**496555 & 496560 - ELECTRICAL PARTS 37 mm**

These coils can be mounted with every Parker ATEX solenoid valves corresponding to the specified Coil Group.  
See column "Coil Group" within valve pages.

**Application:** Control of solenoid valves in dangerous areas where explosion-proof protection Ex db mb IIC T4 to T6 is required.

**Benefits:** Rotatable 360° fibreglass-reinforced plastic housing (class H). Solenoid coil, rectifier (silicium diodes), fuses and varistor protection are completely encapsulated into the coil housing by epoxy resin for shock and corrosion protection.

The plastic housing is delivered with M20 x 1.5 cable gland certified for use "db" protection. Small size for ease of mounting in confined space.



Reference		496555				496560			
Certificate		LCIE 07 ATEX 6075 X - IECEx LCI 07.0014X							
Coil Group		10.2				10.1			
Type of protection	Gas	II 2 G - Ex db mb IIC T4 / T5 / T6				II 2 G - Ex db mb IIC T4			
	Dust	II 2 D - Ex tb IIC - T130°C / 95°C / 80°C				II 2 D - Ex tb IIC - T130°C			
Degree of protection		IP 67 according to IEC/EN 60529 Standards							
Ambiant temperature		-40°C to +65 / 50 / 35°C The application is limited also by the temperature range of the valve.				-40°C to +65°C			
Class of insulation		H (180 °)							
Electrical connection		Electric connection is done in the connection box on an easily accessible connector terminals. The introduction of the cable (Ø min 5 mm, Ømax. 11 mm, section max. 2.5 mm²) in the connection box passes by the built in M20 x 1.5 cable gland.							
Elect. Power	DC	Pn (hot)	-	6 W	-	8 W	-	8 W	-
		P (cold) 20°C	-	7.5 W	-	10.5 W	-	10.5 W	-
	AC	Pn (holding)	6 W	-	8 W	-	8 W	-	8 W
		Attraction cold	7.5 W	-	10.5 W	-	10.5 W	-	10.5 W
Voltages "Un"		VAC/Hz	Code	VDC	Code	VAC/Hz	Code	VDC	Code
-10% to +10% of the Un		230/50-60	P9	24	C2	230/50-60	P9	24	C2
		110/50-60	P2	48	C4	110/50-60	P2	48	C4
		24/50-60	P0	110	C5	24/50-60	P0	110	C5
		48/50-60	S4	-	-	48/50-60	S4	-	-

**To Order a Coil choose** Coil Ref + Voltage Code, example: 496555 for 24 VDC = **496555C2**

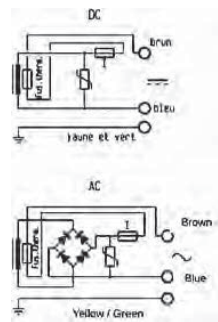
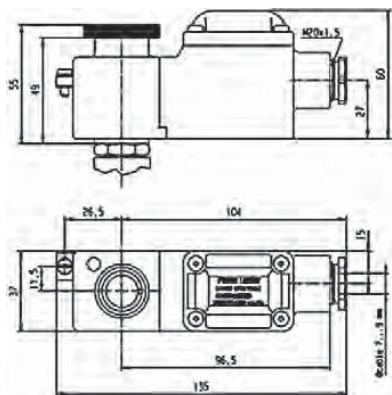

**EXPLOSION PROOF  
ELECTRICAL PARTS**

COIL GROUP

**10.2/10.1**

**FLAME PROOF ENCAPSULATED  
ELECTRICAL PARTS  
"db mb"**



**ZONE 1/21**

**496700 & 496800 - ELECTRICAL PARTS 37 mm**

These coils can be mounted with every Parker ATEX solenoid valves corresponding to the specified Coil Group.  
See column "Coil Group" within valve pages.

**Application:** Control of solenoid valves in dangerous areas where explosion-proof protection Ex db mb IIC T4 to T6 is required.

**Benefits:** Rotatable 360° fibreglass-reinforced plastic housing (class H). Solenoid coil, rectifier (silicium diodes), fuses and varistor protection are completely encapsulated into the coil housing by epoxy resin for shock and corrosion protection.

The plastic housing is delivered with 1/2" NPT or M20 x 1.5 threaded hole for wide range of cable glands. Small size for ease of mounting in confined space.



Reference	496700 or 496700.02 (NPT)				496800 or 496800.02 (NPT)				
Certificate	LCIE 10 ATEX 3059 X - IECEx LCI 10.0023X								
Coil Group	10.2				10.1				
Type of protection	Gas	II 2 G - Ex db mb IIC T4 / T5 / T6				II 2 G - Ex db mb IIC T4			
	Dust	II 2 D - Ex tb IIC - T130 / 95 / 80°C				II 2 D - Ex tb IIC - T130°C			
Degree of protection	IP67 according to IEC/EN 60529 Standards								
Ambiant temperature	-40°C to +35°C / +50°C / +65°C The application is limited also by the temperature range of the valve.				-40°C to +65°C				
Class of insulation	H (180°)								
Electrical connection	Electric connection is done in the connection box passes through a 1/2 NPT or M20x1.5 thread in which a certified Ex dBIIC cable gland must be installed								
Elect. Power	DC	Pn (hot)	-	6 W	-	8 W			
		P (cold) 20°C	-	7.5 W	-	10.5 W			
	AC	Pn (holding)	6 W	-	8 W			-	
		Attraction cold	7.5 W	-	10.5 W			-	
Voltages "Un"	VAC/Hz	Code	VDC	Code	VAC/Hz	Code	VDC	Code	
-10% to +10% of the Un	230/50-60	P9	24	C2	230/50-60	P9	24	C2	
	110/50-60	P2	48	C4	110/50-60	P2	48	C4	
	24/50-60	P0	110	C5	24/50-60	P0	110	C5	
	48/50-60	S4			48/50-60	S4			

To Order a Coil choose Coil Ref + Voltage Code, example: 496700 for 24 VDC = 496700C2

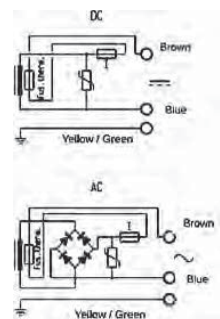
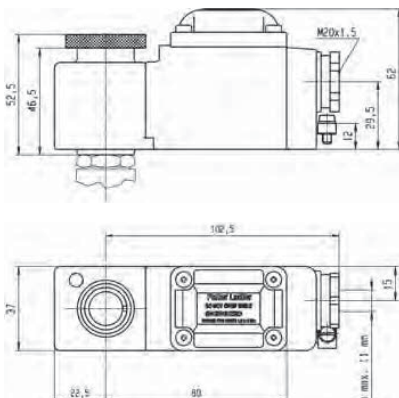



**EXPLOSION PROOF  
ELECTRICAL PARTS**

COIL GROUP

**2.0/2.1**

**INCREASED SAFETY  
ELECTRICAL PARTS  
"eb"**



**ZONE 1/21**

**483371 & 494040 - ELECTRICAL PARTS 50 MM**

This coil can be mounted with every Parker ATEX solenoid valves corresponding to the specified Coil Group.  
See column "Coil Group" within valve pages.

**Application:** Control of solenoid valves in dangerous areas where explosion-proof protection Ex eb IIC T3 or T4 is required.

**Benefits:** Rotatable housing 360°, epoxy varnished steel with internal and external screw terminals for earth connection.

Small size for ease of mounting in confined space. Simplifies conversion of existing equipment to hazardous area requirements.



Reference		483371				494040				
Certificate		LCIE 02 ATEX 6011 X				LCIE 02 ATEX 6013 X				
Coil Group		2.0 / 2.1								
Type of protection	Gas	II 2 G - Ex eb IIC T4				II 2 G - Ex eb IIC T3 / T4				
	Dust	II 2 D - Ex tb IIIC - T130°C				II 2 D - Ex tb IIIC - T195°C / T130 °C				
Degree of protection		IP67 according to IEC/EN 60529 Standards								
Ambiant temperature		-40°C to +65°C				-40°C to +90°C / to +65°C				
		The application is limited also by the temperature range of the valve.								
Class of insulation		F 155°C				H (180°)				
Electrical connection		By special cable gland or M20 x 1.5 "Ex eb" on screw terminals for wires up to 1.5 mm². Cables with outside diameter 6.5 mm to 13.5 mm can be simply sealed using the rubber gland with resilient sealing rings supplied.								
Elect. Power	DC	Pn (hot)	8 W				8 W			
		P (cold) 20°C	9 W				9 W			
		Pn (holding)	8 W				8 W			
	AC	Attraction cold	32 VA (9 W)				32 VA (9 W)			
Weight		320 g								
Voltages "Un"		VAC/Hz	Code	VDC	Code	VAC/Hz	Code	VDC	Code	
-10% to +10% of the Un		24/50	A2	24	C2	220-230/50	3D	24	C2	
		48/50	A4	48	C4					
		110-115/50	0A	110	C5					
		220-230/50	3D							

To Order a Coil choose Coil Ref + Voltage Code, example: 483371 for 24 VDC = **483371C2**

**Fuses:**

Both electrical parts have to be connected in series with a safety fuse according to IEC 60127-3.

**483371:**

DC: 24 V, 400 mA - 48V, 250 mA - 110 V, 100 mA  
AC 50Hz: 24 V, 630 mA - 48V, 315 mA - 110 V, 160 mA - 220/230 V, 80 mA

**494040:**

DC: 12 V, 400 mA - 24V, 200 mA - 48 V, 100 mA - 110V, 50 mA  
AC 50Hz: 24 V, 250 mA - 48V, 125 mA - 110/115 V, 63 mA - 220/230 V, 32 mA

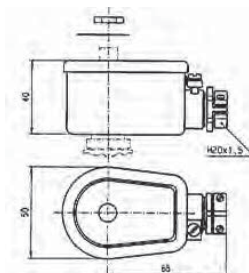

**COIL GROUP**
**10.1**
**INCREASED SAFETY  
AND ENCAPSULATED  
ELECTRICAL PARTS "eb mb"**

**ZONE 1/21**
**492310 - ELECTRICAL PARTS 50 mm**

This coil can be mounted with every Parker ATEX solenoid valves corresponding to the specified Coil Group.  
See column "Coil Group" within valve pages.

**Application:** Control of solenoid valves in dangerous areas where explosion-proof protection Ex eb mb II T4 to T5 is required.

**Benefits:** Rotatable 360° fibreglass-reinforced plastic housing. Solenoid coil, rectifier (silicium diodes), fuses and varistor protection are completely encapsulated into the coil housing by epoxy resin for shock and corrosion protection.

Small size for ease of mounting in confined space.



<b>Reference</b>	<b>492310</b>				
<b>Certificate</b>	<b>LCIE 02 ATEX 6023 X - IECEx LCI 06.0011 X</b>				
<b>Coil group</b>	<b>10.1</b>				
<b>Type of protection</b>	<b>Gas</b>	II 2 G - Ex eb mb II T4 / T5			
	<b>Dust</b>	II 2 D - Ex tb IIIC - T130°C / T95°C			
<b>Degree of protection</b>	<b>IP66</b> according to IEC/EN 60529 Standards				
<b>Ambiant temperature</b>	-40°C to +75°C / to +40°C The operating temperature of the valve/coil can be limited by that of the valve				
<b>Class of insulation</b>	F 155°C				
<b>Electrical connection</b>	Connection box with terminals and cable entry via gland M20 x 1.5 - Possibility for additional earth via external screw.				
<b>Elect. Power</b>	<b>DC</b>	Pn (hot)	6 W		
		P (cold) 20°C	7.5 W		
	<b>AC</b>	Pn (holding)	6 W		
		Attraction cold	7.5 W		
<b>Weight</b>	500 g				
<b>Voltages "Un"</b>	<b>VAC/Hz</b>	<b>Code</b>	<b>VDC</b>	<b>Code</b>	
-10% to +10% of the Un	24/50-60	P0	24	C2	
	48/50-60	S4	48	C4	
	230/50-60	P9	110	C5	

**To Order a Coil choose** Coil Ref + Voltage Code, example: 492310 for 24 VDC = **492310C2**

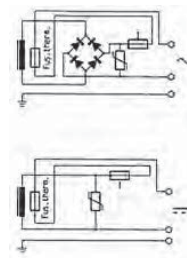
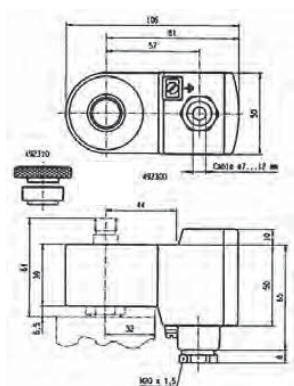

**EXPLOSION PROOF  
ELECTRICAL PARTS**

COIL GROUP

**9.0**

**INCREASED SAFETY  
AND ENCAPSULATED  
ELECTRICAL PARTS "eb mb"**



**ZONE 1/21**

**492210 - ELECTRICAL PARTS "BOOSTER" 50 mm**

These coils can be mounted with every Parker ATEX solenoid valves corresponding to the specified Coil Group.  
See column "Coil Group" within valve pages.

**Application:** Control of solenoid valves in dangerous areas where explosion-proof protection - Ex eb mb IIC T5/T6 is required.

**Benefits:** Rotatable 360° fibreglass-reinforced plastic housing. Solenoid coil, fuses and varistor protection are completely encapsulated into the coil housing by epoxy resin for shock and corrosion protection. Small size for ease of mounting in confined space. Simplifies conversion of existing equipment to hazardous area requirements.

Available only in 24 VDC (suffix code : C2)



Reference	492210	
Certificate	LCIE 02 ATEX 6023 X - IECEx LCI 06.0011 X	
Coil group	9.0	
Type of protection	Gas	II 2 G - Ex eb mb IIC T5 / T6
	Dust	II 2 D - Ex tb IIIC - T95°C / T80°C
Degree of protection	IP66 according to IEC/EN 60529 Standards	
Ambient temperature	-40°C to +75°C / +40°C The operating temperature of the valve/coil can be limited by that of the valve	
Insulation Class	F 155°C	
Electrical connection	Connection box with terminals and cable entry via gland M20 x 1.5 Possibility for additional earth via external screw	
Power consumption DC	1 to 1.8 W according to length of cable	
Attraction current	I min = 60 mA (I nominal = 75 mA)	
Voltage DC	U nominal = 24 VDC (C2), Umin = 21.6 VDC	
Resistance	23 Ω + (R = 270 Ω)	
Inductance	0 mH	
Capacitance	0 μF	
Response time	2 - 4 s	
Weight	500 g	

To Order a Coil choose Coil Ref + Voltage Code, example: 492210 for 24 VDC = 492210C2

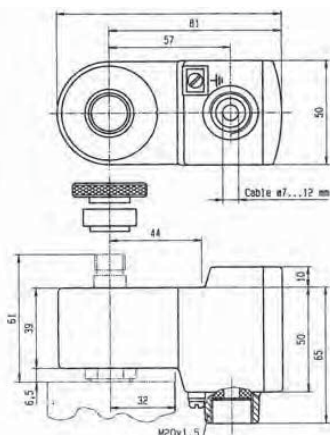

**Indications:**

Booster for Offshore valves

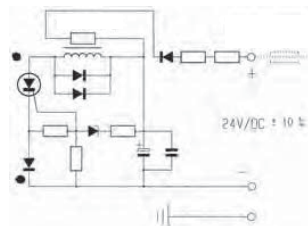

These electrical parts need an external fuse of I = 100 mA



**COIL GROUP**
**2.0/2.1**
**INCREASED SAFETY  
AND ENCAPSULATED  
ELECTRICAL PARTS "eb mb"**

## 492190 - ELECTRICAL PARTS 50 mm

This coil can be mounted with every Parker ATEX solenoid valves corresponding to the specified Coil Group.  
See column "Coil Group" within valve pages.

**Application:** Control of solenoid valves in dangerous areas where explosion-proof protection Ex eb mb IIC T3 to T4 is required.

**Benefits:** Rotatable 360°, fiberglass -reinforced plastic housing. Solenoid coil, rectifier (silicium diodes), fuses and varistor protection are completely encapsulated into the coil housing by epoxy resin for shock and corrosion protection.

Small size for ease of mounting in confined space.

**ZONE 1/21**

<b>Reference</b>	<b>492190</b>			
<b>Certificate</b>	<b>LCIE 02 ATEX 6023 X - IECEx LCI 06.0011 X</b>			
<b>Coil Group</b>	<b>2.0 / 2.1</b>			
<b>Type of protection</b>	<b>Gas</b>	II 2 G - Ex eb mb IIC T3 / T4		
	<b>Dust</b>	II 2 D - Ex tb IIIC - 195°C / 130°C		
<b>Degree of protection</b>	<b>IP66</b> according to IEC/EN 60529 Standards			
<b>Ambient temperature</b>	-40°C to +75°C / +40°C The operating temperature of the valve/coil can be limited by that of the valve			
<b>Insulation Class</b>	F 155°C			
<b>Electrical connection</b>	Connection box with terminals and cable entry via gland M20 x 1.5 Possibility for additional earth via external screw			
<b>Electrical consumption</b>	<b>DC</b>	Pn (hot)	9 W	
		P (cold) 20°C	11 W	
	<b>AC</b>	Pn (holding)	11 W	
		Attraction cold	13 W	
<b>Weight</b>	320 g			
<b>Voltages "Un"</b> -10% to +10% of the Un	<b>VAC/Hz</b>	<b>Code</b>	<b>VDC</b>	<b>Code</b>
	24/50-60	P0	24	C2
	110/50-60	P2	48	C4
	230/50-60	P9	110	C5

**To Order a Coil choose** Coil Ref + Voltage Code, example: 492190 for 24 VDC = **492190C2**

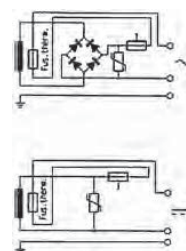
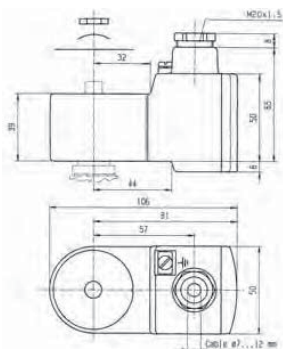

**EXPLOSION PROOF  
ELECTRICAL PARTS**

COIL GROUP

**7.0**

**INTRINSICALLY SAFE  
ELECTRICAL PARTS  
"ia"**



**ZONE 0/20**

**483580 - 483960 ELECTRICAL PARTS 32 mm "IS"**

These coils can be mounted with every Parker ATEX solenoid valves corresponding to the specified Coil Group.

See column "Coil Group" within valve pages.

**Application:** Control of solenoid valves in dangerous areas where explosion-proof protection Ex ia IIC T6 is required.

**Benefits:** Fully encapsulated assembly comprising a coil, metal armature, three diodes circuit and DIN plug connection.

The encapsulation provides an effective compact housing offering full protection against dust, oil, water, etc.

Small size for ease of mounting in confined space. Available only in 28 VDC (suffix code : N7)



Reference (without plug) (with plug)	<b>483580.01 483960.01</b>	
Certificate	<b>LCIE 02 ATEX 6065 X - IECEx LCI 07.0025 X</b>	
Coil Group	<b>7.0</b>	
Type of protection	Gas	II 1 G - Ex ia IIC - T6
	Dust	II 1 D - Ex ta IIC - T80°C
Degree of protection	<b>IP65</b> with plug according to IEC/EN 60529 Standards	
Ambiant temperature	- 40°C à + 55°C The operating temperature of the valve/coil can be limited by that of the valve.	
Electrical connection	The coil is connected with a 2P + E plug according to EN 175301-803 type A Contact 1 is marked as the positive pole ⊕.	
Maximum supply voltage	28 VDC (N7) - 110 mA The minimum operating voltage at maximum 60°C is 14 VDC.	
Power	DC	Minimum
		Maximum
		500 mW
		3 W
Depending on applied voltage, IS barrier type and resistance of connected cable		
Coil resistance at 20°C	340 Ω	
Impedance	340 Ω	
Apparent inductance	0 mH	
Apparent capacitance	0 μF	
Weight	160 g (with plug)	

To Order a Coil choose Coil Ref + Voltage Code, example: 483580 for 28 VDC = **483580N7**

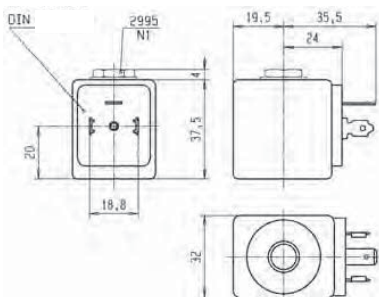

**Important**

The intrinsically safe supply circuit should have enough capacity in all environmental conditions to assure a **minimum operating current of 35 mA** through the coil.

The minimal holding current is 20 mA.

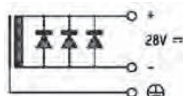

For the barrier compatibility see the corresponding table in in appendix section.

These coil must be used with suitable housing : **Ref. 2995**



**COIL GROUP**
**8.0**
**INTRINSICALLY SAFE  
ELECTRICAL PARTS  
"ia"**

**ZONE 0/20**

## 495910 - MINIWATT - 0.3 W ELECTRICAL PARTS "IS" "BOOSTER" 37 mm

These coils can be mounted with every Parker ATEX solenoid valves corresponding to the specified Coil Group.  
See column "Coil Group" within valve pages.

**Application:** Control of solenoid valves in dangerous areas where explosion-proof protection Ex ia IIC T4 to T6 is required.

**Benefits:** Rotatable 360° fibreglass-reinforced plastic housing (class H). Solenoid coil, rectifier (silicium diodes), fuses and varistor protection are completely encapsulated into the coil housing by epoxy resin for shock and corrosion protection.

Small size for ease of mounting in confined space. Available only in 28 VDC (code: N7).



<b>Reference</b>	<b>495910</b>		
<b>Certificate</b>	<b>LCIE 03 ATEX 6464 X - IECEx LCI 07.0006 X</b>		
<b>Coil Group</b>	<b>8.0</b>		
<b>Type of protection</b>	<b>Gas</b>	II 1 G - Ex ia IIC - T4 / T5 / T6	
	<b>Dust</b>	II 1 D - Ex ta IIIC T80 / 95 / 130°C	
<b>Degree of protection</b>	<b>IP67</b> according to IEC/EN 60529 Standards		
<b>Ambiant temperature</b>	- 40°C to +80°C / 75°C / 65°C The application is limited also by the temperature range of the valve..		
<b>Class of insulation</b>	H 180°C		
<b>Electrical connection</b>	Electric connection is done in the connection box on an easily accessible connector terminals. The introduction of the cable (Ø min 7 mm, Ømax. 11 mm, section max. 2.5 mm <sup>2</sup> ) in the connection box passes by the built in M20 x 1.5 cable gland		
<b>Maximum supply voltage</b>	28 VDC (N7) - 110 mA		
<b>Power</b>	<b>DC</b>	<b>Minimum</b>	0.3 W (with 13 VDC)
		<b>Maximum</b>	1.2 W (with 24 VDC)
		Depending on applied voltage, IS barrier type and resistance of connected cable	
<b>Line check</b>	4 mA or 5 VDC max		
<b>Coil resistance at 20°C</b>	Charge ~ 550 Ω - Holding ~ 500 Ω		
<b>Impedance</b>	0 mH		
<b>Apparent inductance</b>	0 µF		
<b>Response time</b>	2 - 3 s		
<b>Weight</b>	500 g		

**To Order a Coil choose** Coil Ref + Voltage Code, example: 495910 for 28 VDC = **495910N7**

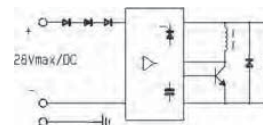
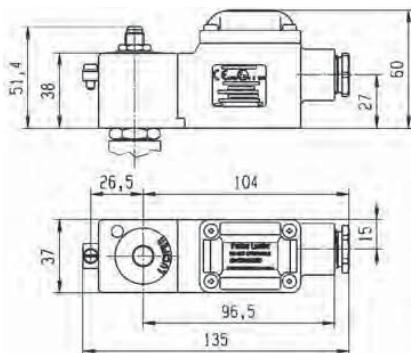

509

Parker Hannifin Corporation  
Fluid Control Division Europe  
General Catalogue FCDE/0110/UK/V2.0

**EXPLOSION PROOF  
ELECTRICAL PARTS**

COIL GROUP

**9.0**

**INTRINSICALLY SAFE  
ELECTRICAL PARTS  
"ia"**



**ZONE 0/20**

**496565 ELECTRICAL PARTS "BOOSTER"  
"IS" 37 mm**

This coil can be mounted with every Parker ATEX solenoid valves corresponding to the specified Coil Group. See column "Coil Group" within valve pages.

**Application:** Control of solenoid valves in dangerous areas where explosion-proof protection Ex ia IIC T4 to T6 is required.

**Benefits:** Rotatable 360° fibreglass-reinforced plastic housing (class H). Solenoid coil, rectifier (silicium diodes), fuses and varistor protection are completely encapsulated into the coil housing by epoxy resin for shock and corrosion protection.

The plastic housing is delivered with M20 x 1.5 cable gland. Small size for ease of mounting in confined space. Available only in 28 VDC (code: N7).



Reference	496565	
Certificate	LCIE 08 ATEX 6071 X - IECEx LCI 08.0030 X	
Coil group	9.0	
Type of protection	Gas	II 1 G - Ex ia IIC - T4 / T5 / T6
	Dust	II 1 D - Ex ta IIIC - T80 / T95 / T130°C
Degree of protection	IP67 according to IEC/EN 60529 Standards	
Ambiant temperature	- 40°C to +80 / 75 / 65°C The application might also be limited by the temperature range of the valve.	
Electrical connection	Cable connection through a plastic cable gland M20 x 1.5 allowing use of cable diameter from 7 to 12 mm. Additional earth connection possible with external screw terminal.	
Class of insulation	H180°C	
Minimum Courant of function	20 mA	
Minimum voltage of function at 60°C	28 VDC (N7)	
Safety parameters	28 V / 110 mA / 0.77 W	28 V / 280 mA / 1.96 W
Maximum acceptable values: Ui (V) / Ii (mA) / Pi (W)	27 V / 120 mA / 0.81 W	27 V / 320 mA / 2.16 W
	26 V / 135 mA / 0.88 W	26 V / 350 mA / 2.27 W
	25 V / 150 mA / 0.94 W	25 V / 390 mA / 2.43 W
	24 V / 170 mA / 1.02 W	24 V / 430 mA / 2.58 W
Line check	4 mA or 5 VDC max	
Apparent Impedance Typ.	Attraction ~ 600 Ω - Holding ~ 570 Ω	
Apparent Inductance	0 mH	
Apparent Capacitance	0 µF	
Response Time Typ.	2 - 4 s	
Weight	500 g	

**To Order a Coil choose** Coil Ref + Voltage Code, example: 496565 for 28 VDC = **496565N7**

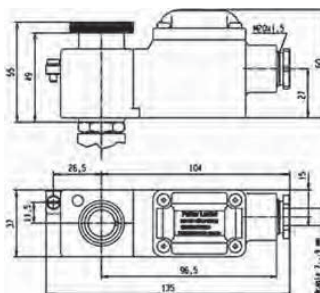

**COIL GROUP**
**9.0**
**INTRINSICALLY SAFE  
ELECTRICAL PARTS  
"ia"**

**ZONE 0/20**

## 492965 ELECTRICAL PART "BOOSTER" "IS" 50 mm

This coil can be mounted with every Parker ATEX solenoid valves corresponding to the specified Coil Group.  
See column "Coil Group" within valve pages.

**Application:** Control of solenoid valves in dangerous areas where explosion-proof protection Ex ia IIC - T6 is required.

**Benefits:** Rotatable 360° fibreglass-reinforced plastic housing. Solenoid coil, fuses and varistor protection are completely encapsulated into the coil housing by epoxy resin for shock and corrosion protection. Small size for ease of mounting in confined space. Simplifies conversion of existing equipment to hazardous area requirements.

Small size for ease of mounting in confined space. Available only in 28 VDC.



Reference	492965.01 - (Stainless steel fixation) 492965.02 - (Plastic fixation)	
Certificate	LCIE 02 ATEX 6066 X - IECEx LCI 07.0007 X	
Coil Group	9.0	
Type of protection	Gas	II 1 G - Ex ia IIC - T6
	Dust	II 1 D - Ex ta IIIC - T80°C
Degree of protection	IP66 according to IEC/EN 60529 Standards	
Ambiant temperature	- 40°C to +65°C	
	The application is limited also by the temperature range of the valve.	
Electrical connection	Cable connection through a plastic or stainless steel cable gland M20 x 1.5 allowing use of cable diameter from 10 to 12 mm. Additional earth connection possible with external screw terminal.	
Class of insulation	H180°C	
Maximum supply voltage	28 VDC (N7) - 110 mA	
Power	DC	Minimum
		Maximum
		0.3 W (with 13 VDC)
		2.3 W (with 24 VDC)
Depending on applied voltage, IS barrier type and resistance of connected cable		
Line check	4 mA or 5 VDC max	
Coil resistance at 20°C	85 Ω	
Impedance	275 Ω (with 13 VDC) - 260 Ω (with 24 VDC)	
Apparent inductance	0 mH	
Apparent capacitance	0 μF	
Response time	2 - 4 s	
Weight	500 g	

To Order a Coil choose Coil Ref + Voltage Code, example: 492965.01 for 28 VDC = **492965.01N7**

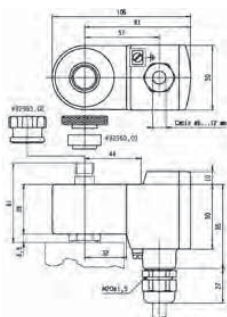

### Important

The intrinsically safe supply circuit should have enough capacity in all environmental conditions to assure a **minimum operating current of 29 mA** through the coil.

The minimal holding current is 20 mA.

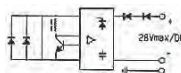

For the barrier compatibility see the corresponding table in appendix section.



**EXPLOSION PROOF  
ELECTRICAL PARTS**

COIL GROUP

**12.0**

**INTRINSICALLY SAFE  
ELECTRICAL PARTS  
"ia"**



**ZONE 0/20**

**482870.01 & 492335 "NEMA"  
ELECTRICAL PARTS "IS" 50 mm**

These coils can be mounted with every Parker ATEX solenoid valves corresponding to the specified Coil Group. See column "Coil Group" within valve pages.

**Application:** Control of solenoid valves in dangerous areas where an explosion-proof protection Ex ia IIC - T6 is required.

**Benefits:** Rotatable 360° housing, polyamid with fibreglass housing and cover. Coil, electronic circuits and other elements required for intrinsic safety are completely encapsulated in the housing with epoxy material for shock and corrosion protection.

Small size for ease of mounting in confined space.



Reference	482870.01		492335	
Certificate	LCIE 02 ATEX 6024 X		LCIE - FM - CSA	
Coil Group	<b>12.0</b>			
Type of protection	Gas	II 1 G - Ex ia IIC - T6	Cl. I, Div.I, Gr. A, B, C, D, Cl. II, Div.I, Gr. E, F, G	
	Dust	II 1 D - Ex ta IIIC - T80°C		
Degree of protection	IP66 according to IEC/EN 60529 Standards		NEMA 4 - 4X	
Ambiant temperature	- 40°C to +65°C The application is limited also by the temperature range of the valve.		+60°C	
Class of insulation	H180°C			
Electrical connection	Cable connection through a stainless steel cable gland M20 x 1.5 allowing use of cable diameter from 10 to 12 mm. Additional earth connection possible with external screw terminal.			
Maximum supply voltage	28 VDC (N7) - 110 mA		30 VDC (L8) - 100 mA	
Power	DC	Minimum	300 mW	
		Maximum	3 W	
		Depending on applied voltage, IS barrier type and resistance of connected cable		
Coil resistance at 20°C			295 Ω	
Impedance			345 Ω	
Apparent inductance			0 mH	
Apparent capacitance			0 μF	
Weight			500 g	

To Order a Coil choose Coil Ref + Voltage Code, example: 492335 for 30VDC = **492335L8**

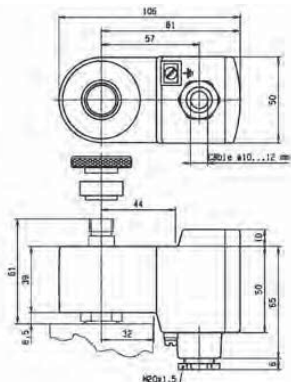

**Important**

The intrinsic safety supply circuit must have sufficient capacitance in all ambient conditions to guarantee a minimum operating current in excess of **29 mA** across the coil.

The minimum current for holding in the energised position is 20 mA

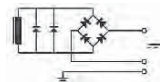

For the barrier compatibility see the corresponding table in appendix section.



**COIL GROUP**
**7.0**
**INTRINSICALLY SAFE  
ELECTRICAL PARTS  
"ia"**

## 488650.01 & 490885 "NEMA" ELECTRICAL PARTS "IS" 50 mm

This coil can be mounted with every Parker ATEX solenoid valves corresponding to the specified Coil Group.

See column "Coil Group" within valve pages.

**Application:** Control of solenoid valves in dangerous areas where explosion-proof protection Ex ia IIC - T6 is required.

**Benefits:** Rotatable 360° housing, polyamid with fibreglass housing and cover. Coil, electronic circuits and other elements required for intrinsic safety are completely encapsulated in the housing with epoxy material for shock and corrosion protection.

Small size for ease of mounting in confined space.

**ZONE 0/20**

Reference		488650.01	490885
Certificate		LCIE 02 ATEX 6024 X	LCIE / FM / CSA
Coil Group		7.0	
Type of protection	Gas	II 1 G - Ex ia IIC - T6	Cl. I, Div.I, Gr. A, B, C, D, Cl. II, Div.I, Gr. E, F, G
	Dust	II 1 D - Ex ta IIIC - T80°C	
Degree of protection		IP66 according to IEC/EN 60529 Standards	NEMA 4 - 4X
Ambiant temperature		- 40°C to +65°C The operating temperature of the valve/coil can be limited by that of the valve.	60°C
Electrical connection Cable entry through a cable gland M20 x1.5. Screw terminals for leads 3 x 1.5 mm <sup>2</sup> max. Additional earth connection possible with external screw terminal			
Class of insulation		H180°C	
Maximum supply voltage		28 VDC (N7) - 110 mA The minimum operating voltage at maximum 60°C is 11.5 VDC.	30 VDC(L8) - 100 mA
Power	DC	300 mW	
	Minimum Maximum	3 W	
Dependent on the applied voltage, type of barrier IS and the resistance of the connected cable			
Coil resistance at 20°C		295 Ω	
Impedance		345 Ω	
Apparent inductance		0 mH	
Apparent capacitance		0 μF	
Weight		500 g	

To Order a Coil choose Coil Ref + Voltage Code, example: 490885 for 30VDC = **490885L8**

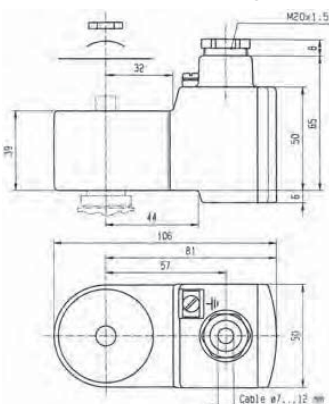

### Important

The intrinsically safe supply circuit should have enough capacity in all environmental conditions to assure a **minimum operating current of 29 mA** through the coil.

The minimal holding current is 20 mA.

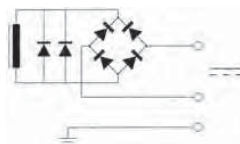

For the barrier compatibility see the corresponding table in appendix section.



**EXPLOSION PROOF  
ELECTRICAL PARTS**

COIL GROUP

**7.0**

**INTRINSICALLY SAFE  
ELECTRICAL PARTS  
"ia"**



**ZONE 0/20**

**488660.01 & 490890 " NEMA "  
ELECTRICAL PARTS "IS" 50 mm**

These coils can be mounted with every Parker ATEX solenoid valves corresponding to the specified Coil Group. See column "Coil Group" within valve pages.

**Application:** Control of solenoid valves in dangerous areas where explosion-proof protection Ex ia IIC T6 is required.

**Benefits:** Rotatable 360° housing, epoxy varnished steel housing and cover. Coil, electronic circuits and other elements required for intrinsic safety are completely encapsulated in the housing with epoxy material for shock and corrosion protection.

Small size for ease of mounting in confined space.



Reference	488660.01		490890	
Certificate	LCIE 02 ATEX 6024 X		LCIE / FM / CSA	
Coil Group	7.0			
Type of protection	Gas	II 1 G - Ex ia IIC - T6	Cl. I, Div.I, Gr. A, B, C, D	
	Dust	II 1 D - Ex ta IIIC - T80°C	Cl. II, Div.I, Gr. E, F, G	
Degree of protection	IP67 according to IEC/EN 60529 Standards		NEMA 4 - 4X	
Ambiant temperature	- 40°C to +65°C		+60°C	
	The operating temperature of the valve/coil can be limited by that of the valve			
Electrical connection	Cable connection (2 x 1 mm <sup>2</sup> ) with cable gland M20 x1.5, external earth screw connection.			
Class of insulation	H180°C			
Maximum supply voltage	28 VDC - 110 mA (N7)		30 VDC - 100 mA (L8)	
The minimum operating voltage at maximum 60°C is 11.5 VDC.				
Power	DC	Minimum	300 mW	
		Maximum	3 W	
Dependent on the applied voltage, type of barrier IS and the resistance of the connected cable				
Coil resistance at 20°C	295 Ω			
Impedance	345 Ω			
Apparent inductance	0 mH			
Apparent capacitance	0 μF			
Weight	500 g			

To Order a Coil choose Coil Ref + Voltage Code, example: 490890 for 28 VDC = **490890N7**

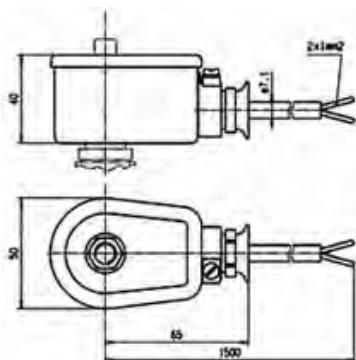

**Important**

The intrinsic safety supply circuit must have sufficient capacitance in all ambient conditions to guarantee a minimum operating current in excess of **29 mA** across the coil.

The minimum current for holding in the energised position is 20 mA.

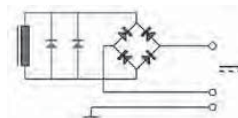

For the barrier compatibility see the corresponding table in appendix section.



**COIL GROUP**
**7.0**
**INTRINSICALLY SAFE  
ELECTRICAL PARTS  
"ia"**

## 488670.01 - ELECTRICAL PARTS "IS" 50 mm

This coil can be mounted with every Parker ATEX solenoid valves corresponding to the specified Coil Group.  
See column "Coil Group" within valve pages.

**Application:** Control of solenoid valves in dangerous areas where explosion-proof protection Ex ia IIC - T6 is required.

**Benefits:** Rotatable 360° housing, epoxy varnished steel housing and cover. Coil, electronic circuits and other elements required for intrinsic safety are completely encapsulated in the housing with epoxy material for shock and corrosion protection.

Small size for ease of mounting in confined space.

**ZONE 0/20**

<b>Reference</b>	<b>488670.01</b>	
<b>Certificate</b>	<b>LCIE 02 ATEX 6024 X</b>	
<b>Coil group</b>	<b>7.0</b>	
<b>Type of protection</b>	<b>Gas</b>	II 1 G - Ex ia IIC - T6
	<b>Dust</b>	II 1 D - Ex ta IIC - T80°C
<b>Degree of protection</b>	<b>IP65</b> according to IEC/EN 60529 Standards	
<b>Ambiant temperature</b>	- 40°C to +65°C The operating temperature of the valve/coil can be limited by that of the valve	
<b>Electrical connection</b>	Cable entry through a cable gland M20 x1.5. Screw terminals for leads 3 x 1.5 mm <sup>2</sup> max. Additional earth connection possible with external screw terminal.	
<b>Maximum supply voltage</b>	28 VDC (N7) - 110 mA The minimum operating voltage at maximum 60°C is 11.5 VDC.	
<b>Power</b>	<b>DC</b>	300 mW
	<b>Maximum</b>	3 W
	Dependent on the applied voltage, type of barrier SI and the resistance of the connected cable	
<b>Coil resistance at 20°C</b>	295 Ω	
<b>Impedance</b>	345 Ω	
<b>Apparent inductance</b>	0 mH	
<b>Apparent capacitance</b>	0 μF	
<b>Weight</b>	500 g	

To Order a Coil choose Coil Ref + Voltage Code, example: 488670.01 for 28 VDC = **488670.01N7**

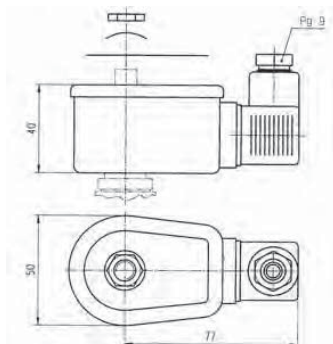

### Important

The intrinsic safety supply circuit must have sufficient capacitance in all ambient conditions to guarantee a minimum operating current in excess of **29 mA** across the coil.

The minimum current for holding in the energised position is 20 mA.

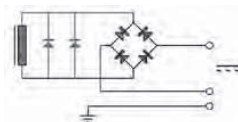

For the barrier compatibility see the corresponding table in appendix section.



HOUSINGS

## TABLE OF CONTENT

### INTRODUCTION

Index for Explosion Proof Electrical Parts.....	442
List of Coil Groups .....	443

### COILS

Coils for DIN plug connection.....	446
Coils with flying leads.....	469
Coils with screw terminal.....	474
Coils with ISO-DIN connector.....	481

### EXPLOSION PROOF ELECTRICAL PARTS

Level of protection "nAc nCc" .....	484
Level of protection "db" .....	492
Level of protection "mb" .....	494
Level of protection "db mb" .....	499
Level of protection "eb" .....	504
Level of protection "eb mb" .....	505
Level of protection "ia" .....	508

<b>HOUSINGS</b> .....	<b>518</b>
-----------------------	------------

<b>COIL ACCESSORIES</b> .....	<b>522</b>
-------------------------------	------------

<b>EXPLOSIVE ENVIRONMENTS</b> .....	<b>524</b>
-------------------------------------	------------

### COIL APPENDICES

Guidance chart for IS-Barriers.....	534
-------------------------------------	-----

## HOUSINGS

### HOUSING

# 4270

## COIL STANDARD HOUSING WITH SCREW TERMINALS

### Standard housing:

<b>Reference:</b>	<b>4270</b>
<b>Material:</b>	Epoxy varnished steel with cathaphoresis traitement
<b>Degree of protection:</b>	IP according to IEC/EN 60529 IP 10 with armoured conduit IP 44 with cable gland
<b>Electrical connection:</b>	Can be made with armoured conduit or cable gland M12x1.5. Parts No. 495740 (cable gland M12x1.5) and 484093 to be ordered separately. Grounding connection by screw M3 on the inside of housing base plate.
<b>Weight:</b>	120 g



### Benefits:

This metal housing offers the ideal protection against shocks and corrosion- rotatable 360° - easy mounting in confined spaces - single-nut mounting - light weight - simplifies conversion of existing equipment to other requirements.

### Application:

The majority of the Lucifer® valves can be fitted with this standard housing, and can be mounted with several compatible Lucifer® coils group.

### Compatible coils:

- **481000 - Standard Coil**  
8 W Class F (155°C)
- **483520 - Double-Frequency Coil**  
9 W Class F (155°C)
- **481044 - Standard High-Power Coil**  
14 W Class F (155°C)
- **485100 - Standard High-Temperature Coil**  
8 W Class H (180°C)
- **486265 - High-Temperature and High-Power Coil**  
14 W Class H (180°C)

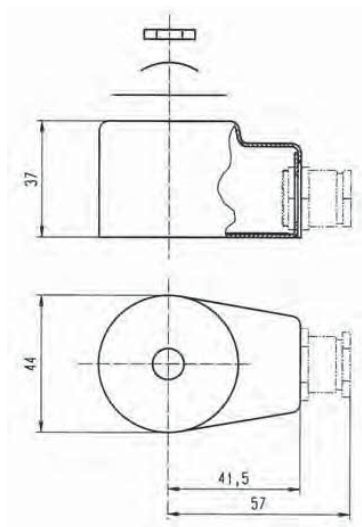

**HOUSING**
**4269**
**HOUSING FOR BISTABLE  
(IMPULSE) COILS**
**Housing for bistable coil:**

<b>Reference:</b>	<b>4269</b>
<b>Material:</b>	Epoxy varnished steel
<b>Degree of protection:</b>	IP according to IEC/EN 60529 IP 10 with armoured conduit IP 44 with cable gland
<b>Electrical connection:</b>	Can be made with armoured conduit or cable gland M12x1.5. Parts No. 484092 and 484093 to be ordered separately. Grounding connection by screw M3 on the inside of housing base plate.
<b>Weight:</b>	120 g

**Benefits:**

This metal housing offers the ideal protection against shocks and corrosion- rotatable 360° - easy mounting in confined spaces - single-nut mounting - light weight - simplifies conversion of existing equipment to other requirements.

**Application:**

This housing is specially designed for group 4.0 coils and can be mounted only with valves controlled by electrical impulses.

**Compatible coils:**

- **484990 - Impulse coil for AC**  
11 W Class F (155°C)
- **485400 - Impulse coil for DC**  
13 W Class F (155°C)

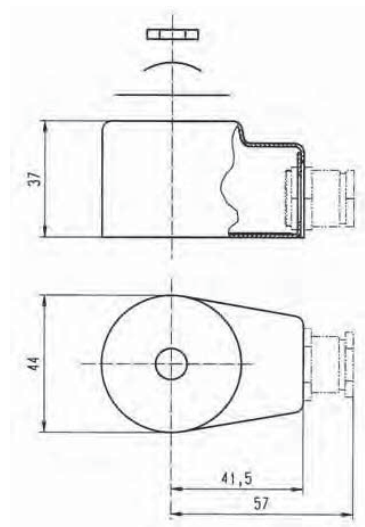

## HOUSINGS

### HOUSING

# 4538

## WATERPROOF AND DUSTPROOF HOUSING

### Waterproof housing:

<b>Reference:</b>	<b>4538</b>
<b>Material:</b>	Epoxy varnished steel
<b>Degree of protection:</b>	IP according to IEC/EN 60529 <b>IP 67</b> with cable gland
<b>Electrical connection:</b>	Cable connection by cable gland M20x1.5 according to DIN 46320. Cable with outer diameter 6.5 - 13.5 mm can be simply sealed using a rubber gland with resilient sealing rings.  The enclosure is internally and externally fitted with grounding and earthing screw terminals.
<b>Weight:</b>	180 g



### Benefits:

This enclosure is dust- and waterproof. It corresponds to the degree of "International Protection" IP 67 according to IEC / EN 60529. Corrosion resistant, the metal housing offers good protection for the coil against shocks and other outside influences - rotatable 360° - easy mounting in confined spaces - easy access to the screw terminals - single-nut mounting - light weight - simple conversion of existing electrical equipment to other requirements without interruption of fluid passage in the valve.

### Application:

This housing can be equipped with several coils of our range, like the standard, double-frequency and magnetic latch coils.

### Compatible coils:

- **481000 - Standard Coil**  
8 W Class F (155°C)
- **483520 - Double-Frequency Coil**  
9 W Class F (155°C)
- **484990 - Impulse Coil for AC**  
11 W Class F (155°C)
- **485400 - Impulse Coil for DC**  
13 W Class H (180°C)

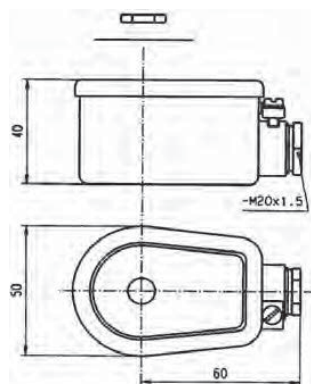

**HOUSING**
**8520**
**WATERPROOF HOUSING  
FOR HIGH-TEMPERATURE COILS**
**Waterproof housing:**

<b>Reference:</b>	<b>8520</b>
<b>Material:</b>	Epoxy varnished steel
<b>Degree of protection:</b>	IP according to IEC/EN 60529 <b>IP 67</b> with cable gland
<b>Electrical connection:</b>	Cable connection by cable gland M20x1.5 according to European standards. Cable with outer diameter 6.5 - 13.5 mm can be simply sealed using a rubber gland with resilient sealing rings. The enclosure is internally and externally fitted with grounding and earthing screw terminals.
<b>Weight:</b>	180 g

**Benefits:**

This enclosure is dust- and waterproof. It corresponds to the degree of "International Protection" IP 67 according to IEC / EN 60529. Corrosion resistant, the metal housing offers good protection for the coil against shocks and other outside influences - rotatable 360° - easy mounting in confined spaces - easy access to the screw terminals - single-nut mounting - light weight - simple conversion of existing electrical equipment to other requirements without interruption of fluid passage in the valve.

**Application:**

The majority of the Parker Lucifer® valves can be fitted with this housing and can be mounted with several compatible Parker Lucifer® coils for high temperature (14 W, 8 W Class F or H).

**Compatible coils:**

- **481044 - High Power Coil**  
14 W Class F (155°C)
- **486265 - High Power Coil**  
14 W Class H (180°C)
- **485100 - Coil for High Temperature**  
8 W Class H (180°C)

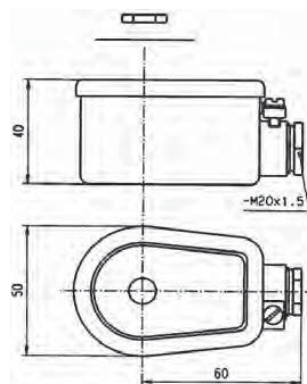

**COIL ACCESSORIES**

**22 mm**  
**32 mm**

**COIL ASSEMBLY KITS**

**COIL ASSEMBLY KIT FOR 22 mm COIL**

The coil assembly kit corresponds to the numbering system for Parker Lucifer® valve housings (Valve - housing - coil/voltage).

It is composed of a nameplate with the details of the valve type, a washer and a nut to secure the 22 mm coil to the valve.

**Caution: This coil assembly kits for 22 mm coils are not adapted for high flow valves, ask your distributor for the adapted kit.**



**KIT OF 100 PIECES**

Reference	Specification	Application
488993.50	Standard - aluminium nameplate - passivated washer and nut - pressure indication in [bar]	Standard valves

**COIL ASSEMBLY KIT FOR 32 mm COIL**

The coil assembly kit corresponds to the "housing" of Parker Lucifer® valve numbering system (Valve - housing - coil/voltage).

It is composed of a nameplate giving details of the valve type, a round washer and a nut to ensure the fixing between 32 mm coil and the valve.



**KIT OF 100 PIECES**

Reference	Specification	Application
482995.50	Standard - Aluminium nameplate - Passivated iron washer and nut - Pressure indication in [bar]	Standards valves



## ACCESSORIES

### DIN PLUG CONNECTOR ACCORDING TO EN 175301-803 -B

No. 481043 for Parker Lucifer® coil  
No. 600040 for Parker coil

Electrical connection suitable for all 22 mm coils  
(e.g. 488980, 481180)



### DIN PLUG CONNECTOR ACCORDING TO EN 175301-803 - A

No. 486586 for standard Parker Lucifer® version  
No. 492645 for high temperature Parker Lucifer® version  
No. 600004 for Parker version

Electrical connection suitable for all 32 mm coils  
(e.g. 481865, 492425)



### METALIC ASSEMBLY KIT

Nut No. 482213 M14 x 1+ Ring No. 482214 +  
O-Ring No. 483917

Coil assembly kit for offshore electrical parts  
(e.g. 482870.01, 492210, 492965.01, 496565, 496700)



### PLASTIC NUT WITH METAL INSERT

No. 8886

For Oil & Gaz electrical parts  
(e.g. 492965.01)



### CABLE GLAND

No. 492398 - Pg 13.5 -Ex eb II  
No. 493841 - M20x1.5 - Ex ia IIC

Electrical connection and mooring cable with 6 to 12 mm diameter, for electrical parts approved "eb mb" or "ia"  
(e.g. 492190, 492965....)



### CABLE GLAND

No. 493426 - 1/2"-14 NPT

Electrical connection and mooring cable with 6 to 12 mm diameter, for flameproof approved electrical parts  
(e.g. 493640)





## INTRODUCTION

Current European regulations concerning electrical equipment for potentially explosive environments are based on optional and partial European directives which require regular modification in the form of application or adaptation directives in order to keep pace with technical developments.

The basic European text in this field, directive **76/117/EC**, which allow the free circulation of goods within the European Union, provides the general framework for the present regulations.

Electrical equipment for use in potentially explosive environments is certified by a government-approved body when it meets relevant European standards (EN 60079-0 and upwards) covering each type of protection (**db, ia, eb, m, p**, etc). Such equipment is then issued with a **an EC type examination certificate**, entitling it to carry the distinctive marking.

This mark opens the way for trading within the European Union and occasionally beyond.

Although largely beneficial, it has revealed certain drawbacks, notably a lack of flexibility and the absence of a global concept for safety. It has now been completely revised by the **new European directive 94/9/EC from March 23, 1994**.

The EC type examination certificate to harmonised standards obtained in compliance with previous directives will remain valid until June 30, 2003, but their validity will cover only conformity to the harmonised standards specified in these directives.

## EUROPEAN MEMBER COUNTRIES





## DEFINITIONS

### EXPLOSIVE ENVIRONMENTS

Mixture with air, under atmospheric conditions, of flammable substances in the form of gases, vapours, mists or dusts in which, after combustion has occurred, combustion spreads to the entire unburned mixture.

### HAZARDOUS AREAS

A hazardous area is an area in which an explosive gas environment is present, or may be expected to be present, in quantities such as to require special precautions for construction, installation and use of electrical apparatus.

### INGREDIENTS FOR AN EXPLOSION

- When combustible materials are mixed with air, an explosive mixture is produced. Danger of explosion therefore exists wherever these hazardous materials are handled: such a condition is to be found on the biggest chemical plant as well as at the smallest filling station.
- Nowadays with the use of electronic and electrical instrumentation in process control, the risk of combustion by electrical energy has increased sharply.
- To protect personnel and expensive equipment special precautions should be taken to prevent combustion of those dangerous substances. Conditions likely to ignite explosive mixtures are as follows:

**Three conditions are enough to create an explosion.**

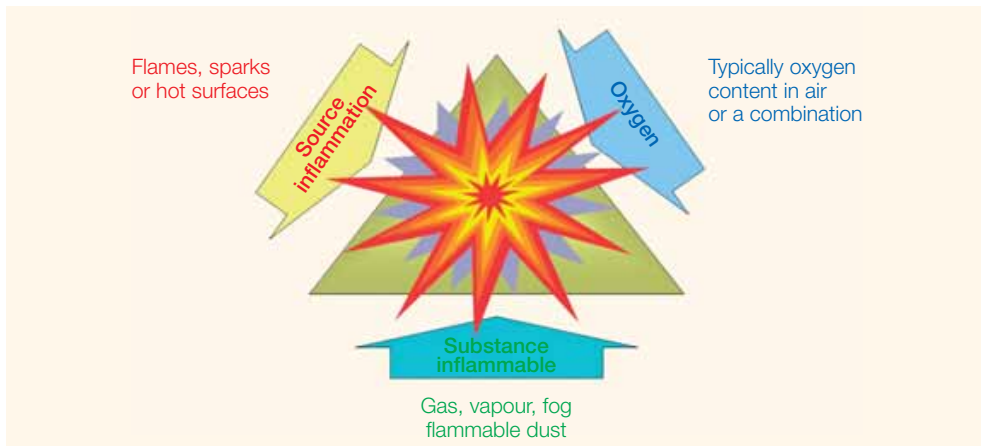

## EXPLOSIVE ENVIRONMENTS



## DEFINITIONS

### ZONES

The hazardous areas are classified in zones based on the frequency of the occurrence and the duration of an explosive gas or dust environment as follows:

Zone 0 (20)	Zone 1 (21)	Zone 2 (22)
An area in which an explosive <b>gas</b> (dust) atmosphere is present CONTINUOUSLY or is present for LONG PERIODS (~1000 h/y).	An area in which an explosive <b>gas</b> (dust) atmosphere is present LIKELY TO OCCUR in normal operation (~10 to 999 h/y).	An area in which an explosive <b>gas</b> (dust) atmosphere is not LIKELY TO OCCUR and if it does occur it will exist for short period only (~1 to 10 h/y).
Mode of protection: <b>ia - ma - px - ...</b>	Mode of protection: <b>db - eb - ib - mb - pxb - ...</b>	Mode of protection: <b>nc - mc - lc - pz - ...</b>

### HAZARDOUS LOCATION CLASSIFICATION

Explosive Environment	Continuous Presence	Intermittent Presence (normal operation conditions)	Occasional Presence (abnormal operation)
IEC	<b>Zone 0</b> (gas) <b>Zone 20</b> (dust)	<b>Zone 1</b> (gas) <b>Zone 21</b> (dust)	<b>Zone 2</b> (gas) <b>Zone 22</b> (dust)
Europe	<b>Zone 0</b> (gas) <b>Zone 20</b> (dust)	<b>Zone 1</b> (gas) <b>Zone 21</b> (dust)	<b>Zone 2</b> (gas) <b>Zone 22</b> (dust)
Canada (CEC) <sup>1</sup> USA (NEC) <sup>2</sup>	<b>Cl. I Div. 1</b> (gas) <b>Cl. II Div. 1</b> (dust) <b>Cl. III Div. 1</b> (fibres)	<b>Cl. I Div. 1</b> (gas) <b>Cl. II Div. 1</b> (dust) <b>Cl. III Div. 1</b> (fibres)	<b>Cl. I Div. 2</b> (gas) <b>Cl. II Div. 2</b> (dust) <b>Cl. III Div. 2</b> (fibres)

<sup>1</sup> (CEC): Code Canadien d'Electricité / <sup>2</sup> (NEC): National Electrical Code

Example:

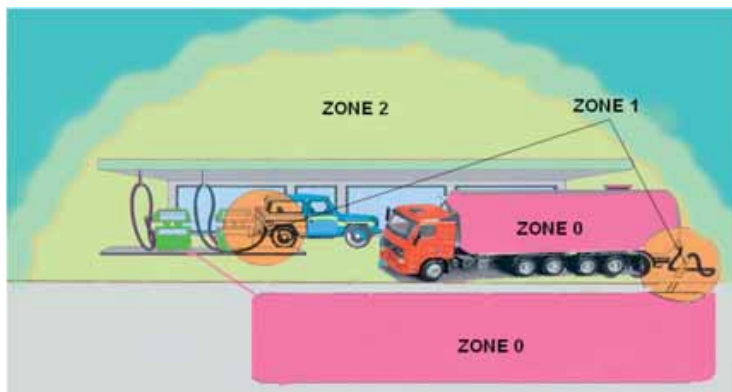



## DEFINITIONS

### HAZARDOUS LOCATION CLASSIFICATION

Category	Fault protection	Atmosphere	Zone	Example of protections
----------	------------------	------------	------	------------------------

**EC Type examination by Notified Body → annex III**

<b>1</b> Very high level	2 types of protection or 2 independent faults	<b>G</b> (Gas)	<b>0</b>	"ia", "ma", "px" or "ia-ma", "db/eb"
		<b>D</b> (Dust)	<b>20</b>	

**EC Type examination by Notified Body → annex III**

<b>2</b> High level	One type of protection Habitual frequent malfunction	<b>G</b> (Gas)	<b>1</b>	One type of protection lb, db, mb, eb, py, o, ...
		<b>D</b> (Dust)	<b>21</b>	

**Internal production inspection → EC declaration of conformity**

<b>3</b> Normal	Required level of protection	<b>G</b> (Gas)	<b>2</b>	n, ic, pz, ... A, C, L, P, R
		<b>D</b> (Dust)	<b>22</b>	

**Hazardous Location Classification**

Group	Gas Reference	Group	Dust Reference
<b>I</b>	Methane	-	-
<b>IIA</b>	Propane	<b>IIIA</b>	Fibres
<b>IIB</b>	Ethylene	<b>IIIB</b>	Non-conductive dust
<b>IIC</b>	Hydrogen / Acetylene	<b>IIIC</b>	Conductive dust

**Surface Temperature Classes**

Class Temperature	Max. Temperature	°C	Gas & Ignition Temperature
<b>T1</b>	450°C	600	560°C Hydrogen <b>T1</b>
<b>T2</b>	300°C	500	537°C Methane <b>T1</b>
<b>T3</b>	200°C	400	425°C Ethylene <b>T2</b>
<b>T4</b>	135°C	300	305°C Acetylene <b>T2</b>
<b>T5</b>	100°C	200	210°C Kerozene <b>T3</b>
<b>T6</b>	85°C	100	160°C Ethylether <b>T4</b>
		0	95°C Carbon disulphide <b>T6</b>



**EXPLOSIVE ENVIRONMENTS**

**PROTECTION MODES**
**PROTECTION MODES**

Concept	Gas	Code	Dust	Gas	Zones	Dust
Flameproof enclosure	<b>db</b>		<b>tb</b>	1/2		21/22
Encapsulation	ma / <b>mb</b> / mc		<b>tb</b> / tc	0/1/2		20/21/22
Increased Safety	<b>eb</b>		-	1/2		-
Intrinsic Safety	<b>ia</b> / ib / ic		<b>ta</b> / tb / tc	0/1/2		20/21/22
Pressurized apparatus	<b>pxb</b> / py / pz		pD	1/2		21/22
Concept Cat. 3 apparatus	<b>nA</b>		-	2		-
	nL		-	2		-
	nR		-	2		-
	<b>nC</b>		-	2		-

In red, protection modes used by parker FCDE.



## STANDARDS AND PROTECTION MODES

### APPARATUS FOR EXPLOSIVE GAS ATMOSPHERES EQUIPMENT GROUP II

EPL	Standards EN / IEC	Protection	Title
	60079-0	-	General requirements
<b>Ga</b>	60079-11	ia	Intrinsic safety
	60079-18	ma	Encapsulation
	60079-26		Equipment with equipment protection level (EPL) Ga (Zone 0)
	60079-28	op is	Protection of equipment and transmission systems using optical radiation
<b>Gb</b>	60079-1	db	Flameproof enclosures
	60079-2	p, pxb, py	Pressurized enclosures
	60079-5	q	Powder filling
	60079-6	o	Oil immersion
	60079-7	eb	Increased safety
	60079-11	ib	Intrinsic safety
	60079-18	mb	Encapsulation
	60079-25		Intrinsically safe systems
	60079-27		Fieldbus intrinsically safe concept (FISCO)
	60079-28	op is op pr op sh	Protection of equipment and transmission systems using optical radiation
<b>Gc</b>	60079-11	ic	Intrinsic safety
	60079-18	mc	Encapsulation
	60079-15	nA	Non sparking
	60079-15	nR	Restricted breathing enclosure
	60079-15	nL	Limited energy (only old edition)
	60079-15	nC	Equipment producing operational sparks
	60079-2	pz	Pressurized enclosures
	60079-27		Concept de réseau de terrain de sécurité intrinsèque (FISCO)
60079-28	op is op pr op sh	Protection of equipment and transmission systems using optical radiation	

EPL = Equipment Protection Level

In red, protection modes used by Parker FCDE.

**EXPLOSIVE ENVIRONMENTS**

**STANDARDS AND PROTECTION MODES**
**ELECTRICAL EQUIPMENT FOR USE IN AREAS WITH COMBUSTIBLE DUST - EQUIPMENT GROUP III**

EPL	Standards EN / IEC	Protection	Title
	60079-0	-	General requirements
Da	60079-31	ta	Protection by enclosure
	60079-11	ia	Protection by intrinsic safety (iA IEC/EN 61241-11)
	61241-18	ma	Protection by encapsulation
Db	60079-31	tb	Protection by enclosure
	60079-11	ib	Protection by intrinsic safety (iB IEC/EN 61241-11)
	60079-18	mb	Protection by encapsulation
	IEC 61241-4	pD	Type of protection "pD"
Dc	60079-31	tc	Protection by enclosure
	60079-11	ic	Protection by intrinsic safety
	60079-18	mc	Protection by encapsulation
	IEC 61241-4	pD	Type of protection "pD"

EPL = Equipement Protection Level

In red, protection modes used by parker FCDE.

**NON ELECTRICAL EQUIPMENT FOR USE IN POTENTIALLY EXPLOSIVE ATMOSPHERE**

Standards	Protection	Title
EN 13463-1	-	Basic method and requirements
EN 13463-2	fr	Protection by flow restricting enclosure
EN 13463-3	db	Protection by flameproof enclosure
EN 13463-5	c	Protection by constructional safety
EN 13463-6	b	Protection by control of ignition source
EN 13463-7	p	Protection by pressurized enclosure
EN 13463-8	k	Protection by liquid immersion

**ZONES AND EQUIPEMENT PROTECTION LEVEL (EPL)**

Gas		Dust	
Zone	EPL	Zone	EPL
0	Ga	20	Da
1	Ga and Gb	21	Da and Db
2	Ga, Gb and Gc	22	Da, Db and Dc

**CATEGORIES AND EQUIPEMENT PROTECTION LEVEL (EPL)**

Categories	Gas	Dust	Safety
1	Ga	Da	Very high
2	Gb	Db	High
3	Gc	Dc	Normal

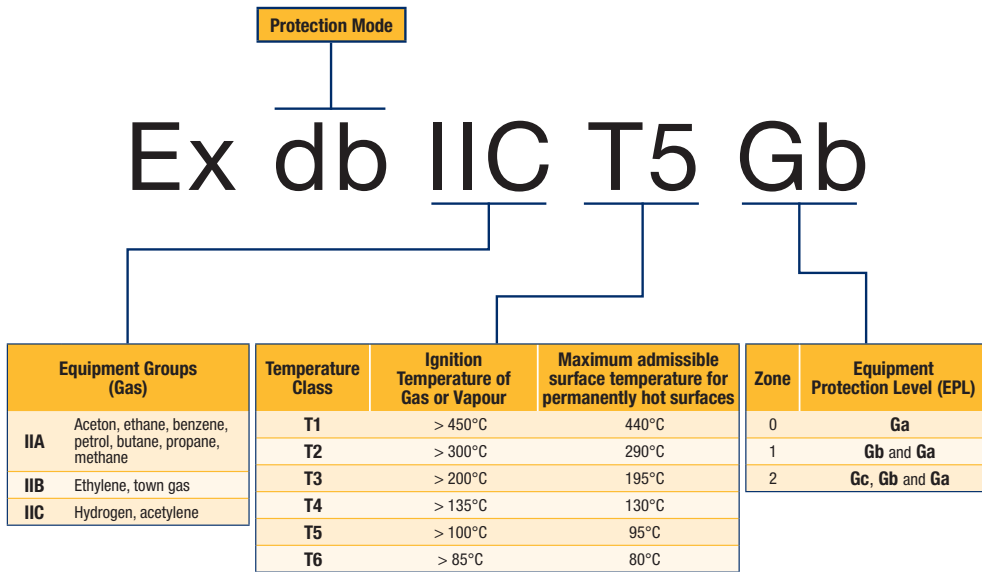
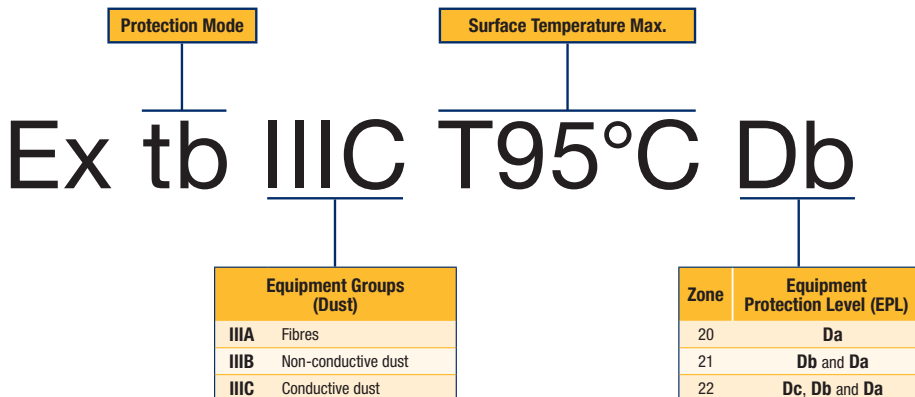

**EXAMPLES OF MARKING**
**ELECTRICAL APPARATUS FOR EXPLOSIVE GAS ATMOSPHERES EQUIPMENT GROUP II**

**ELECTRICAL EQUIPMENT FOR USE IN AREAS WITH COMBUSTIBLE DUST - EQUIPMENT GROUP III**

## EXPLOSIVE ENVIRONMENTS



## WHAT ABOUT THE DIRECTIVE ? (94/9/EC - 1994-03-23)

### WHAT ABOUT THE DIRECTIVE ? (94/9/EC - 1994-03-23)

In keeping with the "**new approach**", the new directive lays down the framework for a total harmonization of regulations covering this field.

It makes no direct references to standards but sets out the essential health and safety requirements to be met and introduces the **CE** marking.

#### ATEX 100 A DIRECTIVE - NEW APPROACH

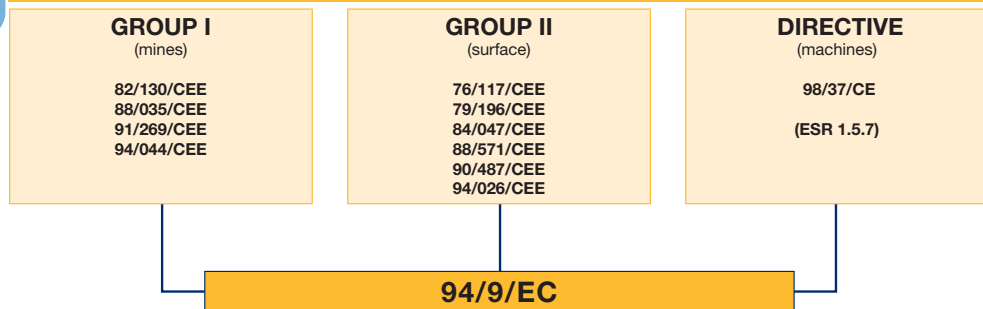

## THE FRAMEWORK OF THE DIRECTIVE

The main principles of the new directive can be summarized as follows:

- It applies to **electric** and **non-electric** equipment.
- It defines **essential health and safety requirements**.
- It takes into consideration **all potential hazards** equipment may cause, in particular at design and production level.
- **The one directive** applies to both **mines** susceptible to fire damp and **surface industries**.
- It stresses the importance of equipment being **used in accordance with its intended purpose**.
- It recognises The European Standards Committee **CEN** and the European Committee for Electrotechnical Standardisation **CENELEC** as competent bodies to fix the required harmonised standards.
- It provides for the **contribution of labour and management**.
- It defines **procedures for assessing conformity** to essential requirements, on the basis of modules which qualify equipment to carry the **CE** mark of conformity.

## APPLICATIONS

The directive applies to the industrial field and concerns the following equipment:

- **Equipment** (machines, apparatus, etc.)
- **Protective systems** (discharge devices, explosion suppression devices, etc.)
- **Components** (parts with no autonomous function, terminals, etc.)
- **Safety devices, controlling devices and regulating devices** intended for use outside potentially explosive environments but required for safety with respect to explosions (relays, barriers, pressure switches, thermostats, etc.)





## WHAT ABOUT THE DIRECTIVE ? (94/9/EC - 1994-03-23)

### EXCLUDED FROM THE SCOPE OF THE NEW DIRECTIVE

The following equipment falls outside the scope of the new directive:

- Medical devices intended for use in a medical environment.
- Equipment and protective systems relating only to the risk of explosion of unstable chemical substances (explosives, etc.)
- Equipment intended for use in domestic and non-commercial environments.
- Personal protective equipment covered by directive 89/686/EC.
- Seagoing vessels and mobile offshore units.
- Means of transport, except for vehicles intended for use in a potentially explosive environment.

### APPLICATION DATES

#### ATEX 100A DIRECTIVE - NEW APPROACH

**94/9/EC**

#### Application dates

• Transposition to national law	1/9/1995
• Application (optional)	1/3/1996
• Application (total)	1/7/2003

### POTENTIAL IGNITION SOURCES AND OTHER HAZARDS TO BE CONTROLLED

The following all represent potential hazards:

- Various sources of ignition, such as sparks, flames, electric arcs, high surface temperature, acoustic energy, optical radiation or electromagnetic waves.
- Static electricity.
- Pressure compensation operations.
- Disturbance from external sources, such as changing environmental conditions, extraneous voltage, humidity, vibration or contamination.

Provision is also made for specific requirements governing devices used to provide additional equipment safety.

These requirements necessitate detailed analysis to assess the operational reliability of such devices and their interaction with other components connected with the equipment.



**COIL APPENDICES**



**GUIDANCE CHART FOR IS-BARRIERS**

Manufacturer	Reference	Ex	IS Standard Electrical Parts						IS Booster Electrical Parts				
			Ex ia IIC T6 488650.01/02 488660.01 488670.01 LCIE/AUS	Ex ia IIC T6 490885 490890 (490895) LCIE/FM/CSA	Ex ia IIC T6 483580.01/03 483960.01/03 LCIE/AUS	Ex ia 490880 (493997) LCIE/FM/CSA	Ex ia IIB T6 482160,01 LCIE	Ex ia IIC T6 482870,01 LCIE	Ex ia 492335 LCIE/FM/CSA	Ex ia IIC T6 492965.01/02 LCIE	Ex ia IIC T6 496565 LCIE	Ex ia IIC T6 495910 LCIE	
A puissance 3	NAEV 22-140	ia	●	-	●	-	●	●	-	●	●	●	
	NAEV 26-100	ia	●	-	●	-	●	●	-	●	●	●	
ABB	V171 132-54	ib	●	-	●	-	●	●	-	●	●	●	
	V171 132-55	ib	●	-	-	-	●	●	-	●	●	●	
	V171 132-61	ia	●	-	-	-	●	●	-	●	●	●	
	DO 890	ib	●	-	-	-	●	●	-	●	●	●	
	S900-D04-EX	ib	●	-	●	-	●	●	-	●	●	●	
BRADLEY	FEX-EX 24V	ia	●	●	●	●	●	-	●	●	●		
COOPER	LB 2101	ia	●	●	●	●	●	●	●	●	●	●	
	LB 2105	ia	●	●	●	●	●	●	●	●	●	●	
	LB 2112	ia	●	●	●	●	●	●	●	●	●	●	
ELCON	1881 / 1882	ia	●	●	●	●	●	●	●	●	●	●	
	471 / 472	ia	●	●	●	●	●	●	●	●	●	●	
	2871/2872	ia	●	●	●	●	●	●	●	●	●	●	
	2874/2875/2876	ia	●	●	●	●	●	●	●	●	●	●	
GEORGIN	AVB 122	ia	●	-	●	-	●	●	-	●	●	●	
	AVB 125	ia	●	-	●	-	●	●	-	●	●	●	
	AVB 128	ia	●	-	●	-	●	●	-	●	●	●	
Hima	F3328A	ib	●	-	●	-	●	●	-	●	●	●	
	F3335	ib	●	-	-	-	●	●	-	●	●	●	
	H4007	ib	●	-	●	-	●	●	-	●	●	●	
MTL	728P, 7128P, 7728P	ia	-	-	-	-	●	-	-	●	●	●	
	728, 7028, 7128, 7728	ia	●	●	●	●	●	●	●	●	●	●	
	3021, 4021, 4021S	ia	●	-	●	-	●	-	-	●	●	●	
	3022	ia	-	-	-	-	●	-	-	-	-	-	
	4023	ia	-	-	-	-	●	-	-	-	-	-	
	4024	ia	●	-	●	-	●	●	-	●	●	●	
	4025	ia	●	●	●	●	●	●	●	●	●	●	
	5021, 5023, 5024	ia	●	-	●	-	●	●	-	●	●	●	
	5025	ia	●	-	●	-	●	●	-	●	●	●	
	4521 / 4523 / 4524	ia	●	-	-	-	●	●	-	●	●	●	
	5521 / 5523 / 5524	ia	●	-	-	-	●	●	-	●	●	●	
	Pepperl & Fuchs	Z 728	ia	●	●	●	●	●	●	●	●	●	●
		Z 779	ia	●	●	●	●	●	●	●	●	●	●
EGA-041-3		ia	-	●	●	●	●	●	-	●	●	●	
KFD2-SD-EX1.36		ia	-	-	-	-	-	●	-	-	-	-	
KFD2-SL-EX1.36		ia	-	-	-	-	-	●	-	-	-	-	
KFD2-SD-EX1.48		ia	-	●	-	-	-	-	-	●	●	●	
KFD2-SL-EX1.48		ia	-	●	-	-	-	-	-	●	●	●	
KFD2-SL- EX1.48.90A		ia	-	-	-	-	-	-	-	●	●	●	
KFD2-SL- EX1.48.90A		ia	-	-	-	-	-	-	-	●	●	●	
KFD2-SL2-EX1.LK		ia	-	●	-	-	-	●	●	●	●	●	
KFD2-SL2-EX2		ia	-	●	-	-	-	●	●	●	●	●	
KSD2-BO-EX		ia	-	-	●	-	-	-	-	●	●	●	
RSD-BO-EX4		ib	-	-	-	-	-	-	-	●	●	●	
RSD-VO-EX8		ib	-	-	-	-	-	-	-	●	●	●	





## GUIDANCE CHART FOR IS-BARRIERS

Manufacturer	Reference	Ex	IS Standard Electrical Parts							IS Booster Electrical Parts		
			Ex ia IIC T6 488650.01/02 488660.01 488670.01 LCIE/AUS	Ex ia IIC T6 490885 490890 (490895) LCIE/FM/CSA	Ex ia IIC T6 483580.01/03 483960.01/03 LCIE/AUS	Ex ia 490880 (493997) LCIE/FM/CSA	Ex ia IIB T6 482160,01 LCIE	Ex ia IIC T6 482870,01 LCIE	Ex ia 492335 LCIE/FM/CSA	Ex ia IIC T6 492965.01/02 LCIE	Ex ia IIC T6 496565 LCIE	Ex ia IIC T6 495910 LCIE
SIEMENS	5RD00-0AB0	ib	-	-	-	-	-	-	-	●	-	-
	7RD00-0AB0	ia	-	-	-	-	-	-	-	●	●	●
	7RD01-0AB0	ia	-	-	-	-	-	-	-	●	●	●
	7RD10-0AB0	ia	-	-	-	-	-	-	-	●	●	●
	7RD11-0AB0	ia	-	-	-	-	-	-	-	●	●	●
	7RD20-0AB0	ia	-	-	-	-	-	-	-	●	●	●
	7RD21-0AB0	ia	-	-	-	-	-	-	-	●	●	●
STAHL	9001/01-252-100-14	ia	●	●	27 V	27 V	●	●	●	●	●	●
	9001/01-280-100-10	ia	●	●	24 V	24 V	●	●	●	●	●	●
	9001/01-280-110-10	ia	●	-	24 V	-	●	●	-	●	●	●
	9002/13-280-100-04	ia	24 V	24 V	27 V	27 V	24 V	24 V	24 V	17 V	17 V	17 V
	9311/52-11-10	ia	-	●	●	25 V	25 V	●	●	●	15 V	15 V
	9111/63-11-00	ia	-	●	●	25 V	25 V	●	●	●	15 V	15 V
	9351/10-15-10	ia	-	●	●	-	-	●	●	●	●	●
	9351/10-16-10	ia	-	●	●	-	-	●	●	●	●	●
	9351/10-17-10	ia	-	-	-	-	-	●	-	-	-	-
	9381/10-187-050-10	ib	-	●	●	●	●	●	●	●	●	●
	9381/10-246-055-10	ib	-	●	●	●	●	●	●	●	●	●
	9381/10-246-070-10	ib	-	●	●	●	●	●	●	●	●	●
	9465/12-04-11	ib	-	●	●	-	-	●	●	●	●	●
	9475/12-04-21	ia/ib	-	●	-	●	-	●	●	●	●	●
	9475/12-04-31	ia/ib	-	-	-	-	-	-	-	●	●	●
	9475/12-08-41	ia/ib	-	-	-	-	-	-	-	-	-	-
	9475/12-08-51	ib	-	-	-	-	-	-	-	●	●	●
	9475/12-08-61	ia/ib	-	-	-	-	-	-	-	-	●	●
	Turck	MK72-S01-EX	ib	-	-	-	-	●	●	-	●	●
MK72-S02-EEX		ib	-	-	-	-	●	●	-	●	●	●
MK72-S04-EEX		ib	●	-	●	-	●	●	-	●	●	●
MK72-S05-EEX		ib	●	-	-	-	●	●	-	●	●	●
MK72-S06-EEX		ib	●	-	●	-	●	●	-	●	●	●
MK72-S07-EEX		ib	●	-	-	-	●	●	-	●	●	●
MK72-S09-EEX		ia	-	-	-	-	-	-	-	-	-	-
MK72-S12-EEX		ia	●	-	●	-	●	●	-	●	●	●
MC72 - 41		ia	●	-	●	-	●	●	-	●	●	●
MC72 - 43		ia	●	-	●	-	●	●	-	●	●	●
BARTEC	07-7331-2301/1000	ia	●	-	-	-	●	●	-	●	-	-
	07-7331-2301/1100	ia	●	-	●	-	●	●	-	●	-	-

If barrier reference not listed, consult factory for compatibility (tech.support@parker.com)

TECHNICAL  
INFORMATION

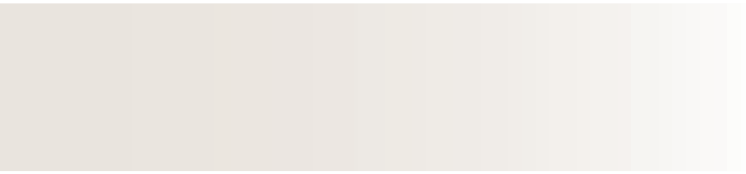

# TECHNICAL INFORMATION ABOUT SOLENOID VALVES

# TECHNICAL INFORMATION ABOUT SOLENOID VALVES

## General Information

Solenoid valves are electro-mechanical devices used for interrupting or diverting the flow of fluids by opening or closing one or more orifices.

**The solenoid valve is a combination of three basic components:**

1. An electromagnet consisting of a solenoid (windings) and a magnetic yoke.
2. A pilot with a moveable plunger (which, in some cases directly opens and closes the valve).
3. A valve body with an orifice opened or closed by plunger or diaphragm to enable or prevent flow of the medium.

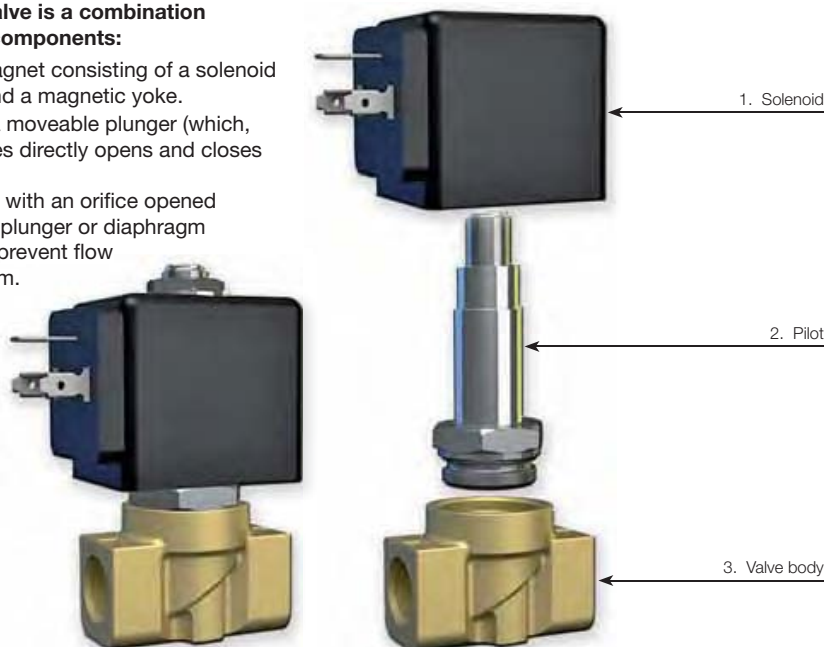

## Operating principles

The term solenoid refers to operator and coil, also known as pilot or magnetic actuator.

The coil consists of copper wire wound on a support reel. When electric current is applied into the coil, magnetic flow lines are generated which are stronger in the coil center.

This magnetic flow raises the moveable plunger in the coil until it brings it into contact with the pole piece. The valve body has an orifice through which the fluid flows when the valve is open.

The moveable plunger has an integral seat which when the solenoid coil is energised, moves off the valve (direct operated) orifice or diaphragm (pilot operated) orifice opening the valve.

When the coil is de-energised, a return spring brings the plunger back to the original closing position, thus cutting off the flow of the fluid.

## BASIC COMPONENTS OF A SOLENOID VALVE

<b>Valve body:</b>	Main part of the solenoid valve including ports, seat and orifices.
<b>Solenoid tube assembly:</b>	Cylinder, in stainless steel, hermetically sealed and closed at one extremity. It is the guide channel of the moveable plunger which is moved magnetically. The solenoid coil is fitted on the external side of the enclosing tube.
<b>Moveable plunger:</b>	Made by ferritic stainless steel, it is attracted by the solenoid magnetic field and slides inside the tube.
<b>Plunger spring (or return spring):</b>	Used to hold the moveable plunger in position and to return it when de-energized.
<b>Seat seal:</b>	Part of the moveable plunger, it is used to close a valves main orifice or pilot orifice.
<b>Electromagnet (or solenoid coil):</b>	Electrical part consisting of a copper windings (solenoid) along, with a magnetic yoke (armature), when electric current flows through, it generates a magnetic field attracting the moveable plunger.
<b>Housing:</b>	Part that contains and protects the coil.
<b>Yoke:</b>	Metalic case surrounding the coil and concentring electro-magnetic force on the moveable plunger.

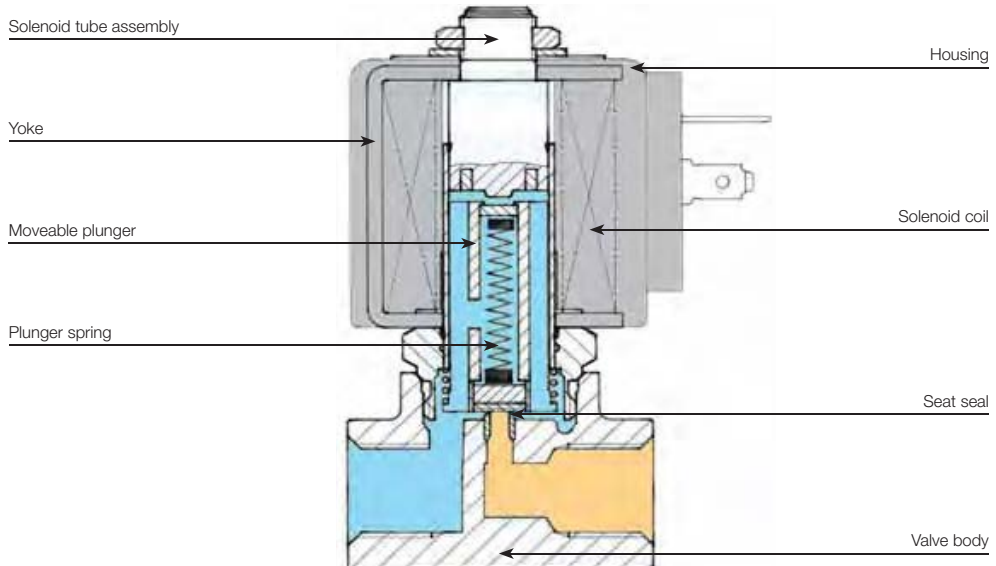

## TECHNICAL INFORMATION

# TECHNICAL VOCABULARY USED IN TABLES

Actuation	Body	Function	Port Size	Orifice (mm)	Flow Factor Kv(l/min)	MOPD (bar)	Max Fluid Temp. (°C)	Page Parker Valves	Page Parker LUCIFER® Valves
-----------	------	----------	-----------	--------------	-----------------------	------------	----------------------	--------------------	-----------------------------

## NORMALLY CLOSED

Port size	Orifice Ø	Flow factors			Operating Pressure Differential			Fluid Temp.		Seat Seal	Parker LUCIFER® Valves			Power		Coil Group	Dwg. No.
		Kv l/min	KV m³/h	Qn l/min	Min bar	Max(MOPD) AC bar	DC bar	Min °C	Max °C		Valve Ref.	Housing Ref.	Coil Ref.	AC W	DC W		

The basic technical features of each solenoid valve are indicated in the tables, the terminology used is shown and explained below. Please notice that in certain sections you will have the choice between two product ranges: Parker valves, within blue tables and the Parker Lucifer valves, within orange tables.

<b>Actuation:</b>	The mechanical method used to control the flow.
<b>Body:</b>	Main part of the solenoid valve with the ports, seats and orifice needed.
<b>Function:</b>	The way the valve operates when de-energised.
<b>Port Size:</b>	Fitting dimensions are defined as threaded in inches (G), in BSP or Sub-base, when a flat interface for ports is adopted.
<b>Orifice (mm):</b>	Main orifice diameter in millimetres (nominal diameter).
<b>Flow Factors:</b>	Define the quantity of water which flows through the solenoid valve with a pressure drop of 1 bar during one minute. Expressed in l/min and m³/h.
<b>Max Fluid Temperature:</b>	Maximum fluid temperature the valve can withstand.
<b>Max Ambient Temperature:</b>	Maximum ambient temperature the valve can withstand.
<b>Minimum Operating Pressure Differential:</b>	The lowest differential pressure required for operation (bar).
<b>Maximum Operating Pressure Differential (MOPD):</b>	The highest working differential pressure with 90% of the rated voltage (-10% Vn) applied to the solenoid coil (for AC) and 95% of the rated voltage (-5% Vn)(for DC).



## NORMALLY CLOSED

Port size	Orifice Ø	Flow factors			Operating Pressure Differential			Fluid Temp.		Seat Seal	Parker Valves			Power		Coil Group	Dwg. No.
		Kv	KV	Qn	Min	Max(MOPD)	Min	Max	Valve Order Number		Valve Type	Coil Type	AC	DC			
BSP	mm	l/min	m³/h	m³/h	bar	AC bar	DC bar	°C	°C				W	W			

<b>Fluid Temperature:</b>	Minimum and Maximum admissible temperature for the media used (°C).
<b>Seat seal:</b>	Material used for the seat discs.
<b>Valve order number:</b>	Applicable for Parker Valves shown in <b>blue</b> tables. The valve order number refers to the valves only. (please refer to the "How To Order" section for more details).
<b>Valve ref.:</b>	Applicable for Parker Lucifer Valves shown in <b>orange</b> tables. The valve ref. refers to the valve. (please refer to the "How To Order" section for more details).
<b>Valve type:</b>	Refers to the Parker valve type
<b>Housing ref.:</b>	Only for Parker Lucifer valves shown in <b>orange</b> tables, you can choose the housing to protect the coil.
<b>Coil Ref.:</b>	Compatible coil reference.
<b>Coil type:</b>	Compatible coil advised.
<b>Power:</b>	Power consumption of a specific electrical part on selected pressure vessel, rated by AC and DC (W). Power consumption must be considered in cold conditions for the coil, at T <sub>Amb</sub> : +20°C. For 483510, 481865 and 496081 series, power consumption indicated in the tables must be considered in warm conditions.
<b>Coil group:</b>	Please refer to the specific section for the coil compatibility groups.
<b>Dwg. No.:</b>	Drawing number.

## TECHNICAL INFORMATION

Solenoid valves are highly engineered products that can be used in many diverse applications.

In addition to operational functionality, media compatibility and suitability for the operating environment when selecting the best product for a given application.

This section provides a brief overview of the components, actuation and function modes of solenoid valves available from Parker Hannifin - FCDE.

### Different Technologies:

Solenoid valves are electrically operated devices used to control flow. The most common types of solenoid valve are:



**Direct Operated  
Valves**



**Magnalift Valves**



**Pilot Operated  
Valves**

# DIRECT OPERATED VALVE

Magnetic force is used directly to open or close the plunger which controls the passage of the fluid. Performances are limited by the coil, the pressure, and the valve orifice size. For direct operated valves, the minimum working pressure is 0 bar and the maximum pressure relies on the combination (valve/coil) chosen.

## Direct Operated Valve

De-energised

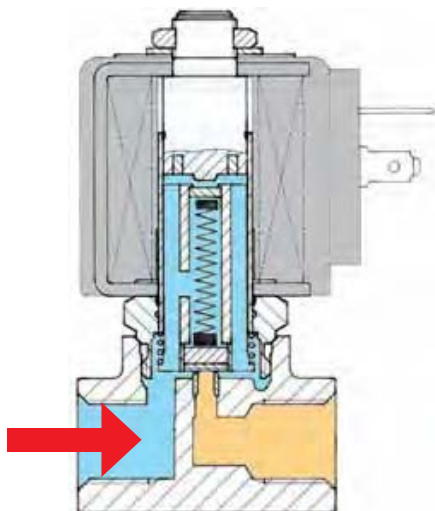

Energised

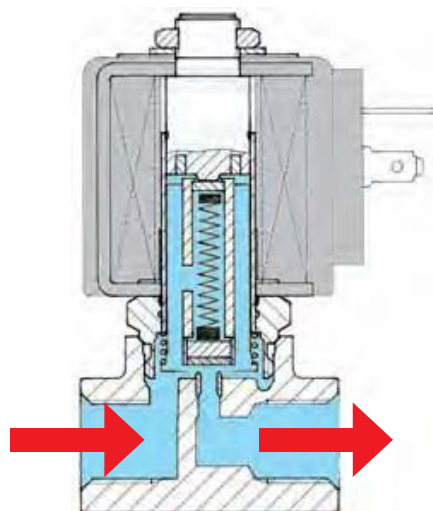

**Example:**

- 121 Series
- 146 Series
- N74 Series

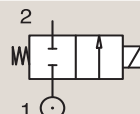

# PILOT OPERATED VALVE

To control a higher flow, it is necessary to use pilot operated valves. The supply pressure enters the direct operated "pilot stage" which directs the flow to a "pilot chamber" which, in turn, applies the pilot pressure over a large area (generally a diaphragm or piston). Therefore, a large force is generated to move the main sealing elements against higher pressure or over a large orifice. One condition of operation is to have a minimum pressure available to shift the valve (indicated in the catalogue). In most applications, this presents no particular problems (refer to magnalift valve section). The pressure rating of the valve starts between 0.1 to 0.5 bar (depending on the valve). (NB. Pilot Operated Valves are also called Servo Operated Valves).

## Pilot Operated Valve

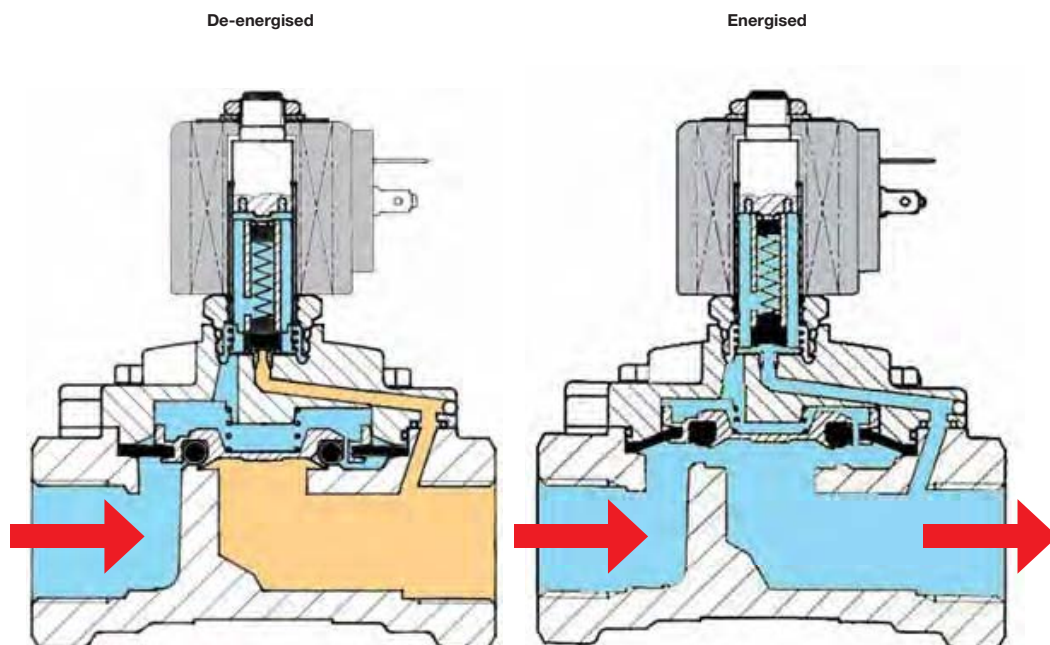
**Example:**

- 321 Series
- 7321B Series
- 168.1 Series

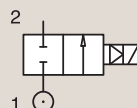

# MAGNALIFT VALVE

The magnalift valves combine the features of the direct operated and pilot operated valves. A mechanical link between the plunger and diaphragm retainer allows the valve to operate as a direct operated valve at low pressures and as a pilot operated valve at higher pressures. Magnalift valves are specially designed for applications where 0 pressure is needed to operate the valve, as well as bigger flow than a direct operated valve.

## Magnalift Operated Valve

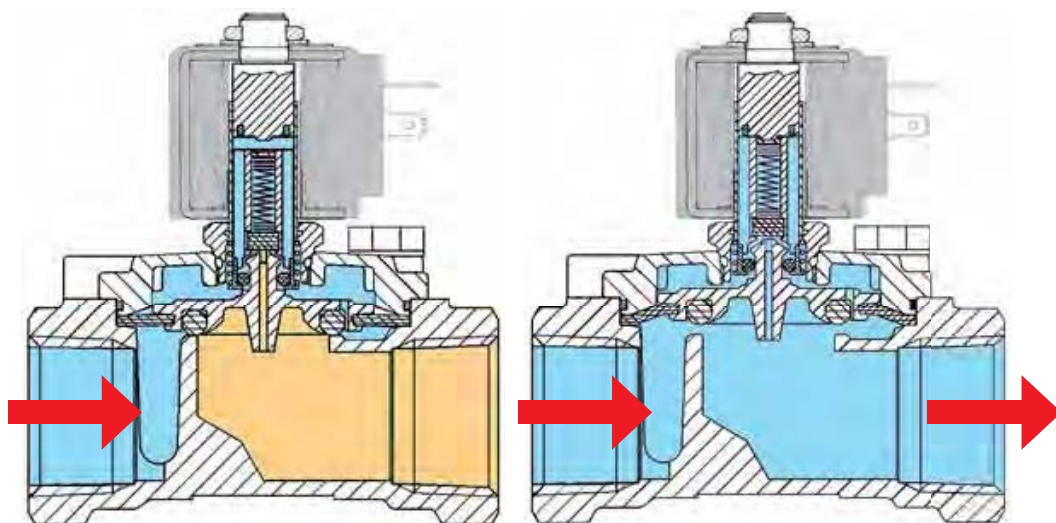
**De-energised**
**Energised**

**Example:**

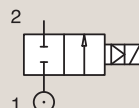
- 221 Series
- 123 Series



## NORMALLY CLOSED VALVE

Most of our valves are available in normally closed and normally open configuration when not energized. In certain applications, you may require a normally open valve (open function in case of current failure). The differentiating factor of design of this technology, is based upon the design of the seat seal, which is reversed in comparison to a normally closed valve.

### Normally Closed Valve

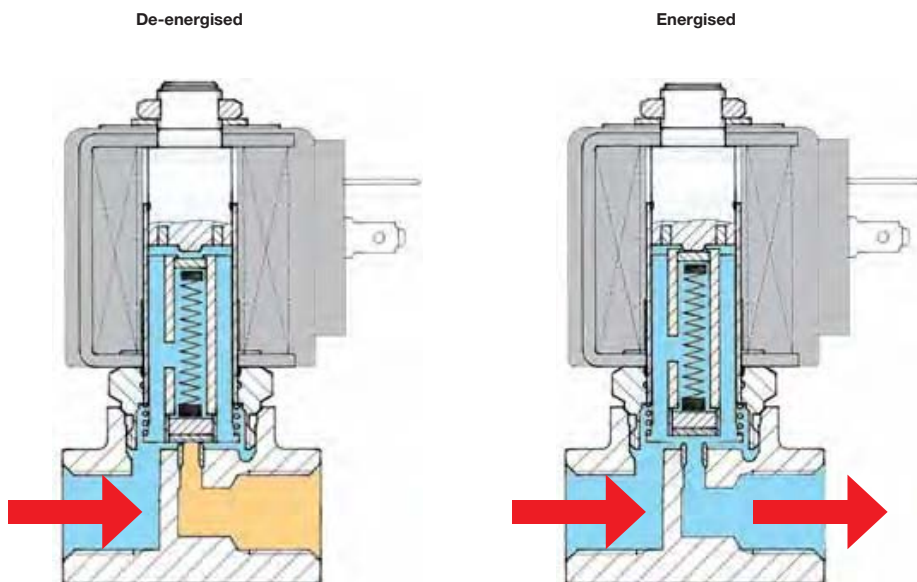

**Example:**

- 121 Series
- 146 Series
- N74 Series

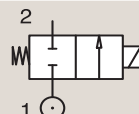

# NORMALLY OPEN VALVE

## Normally Open Valve

De-energised

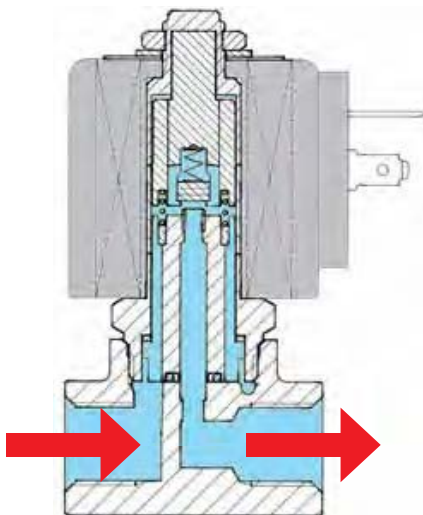

Energised

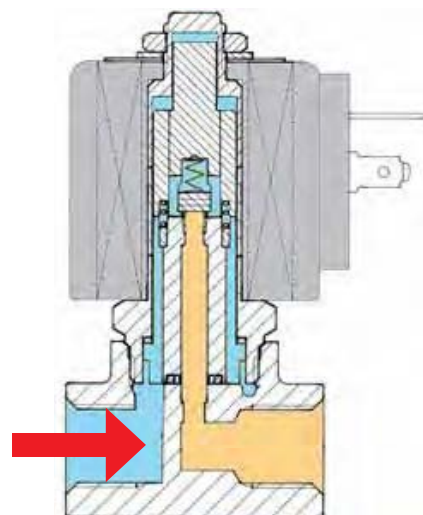

**Example:**

- 122 Series
- 136 Series
- 7322B Series

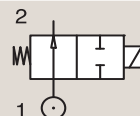

## FLOW AND PRESSURE RANGES

### Area of operation:

Each valve principle, as described in the previous pages, has a defined area of operation related to its pressure and flow capabilities. The following graph shows which type of valve is suitable for a certain situation.

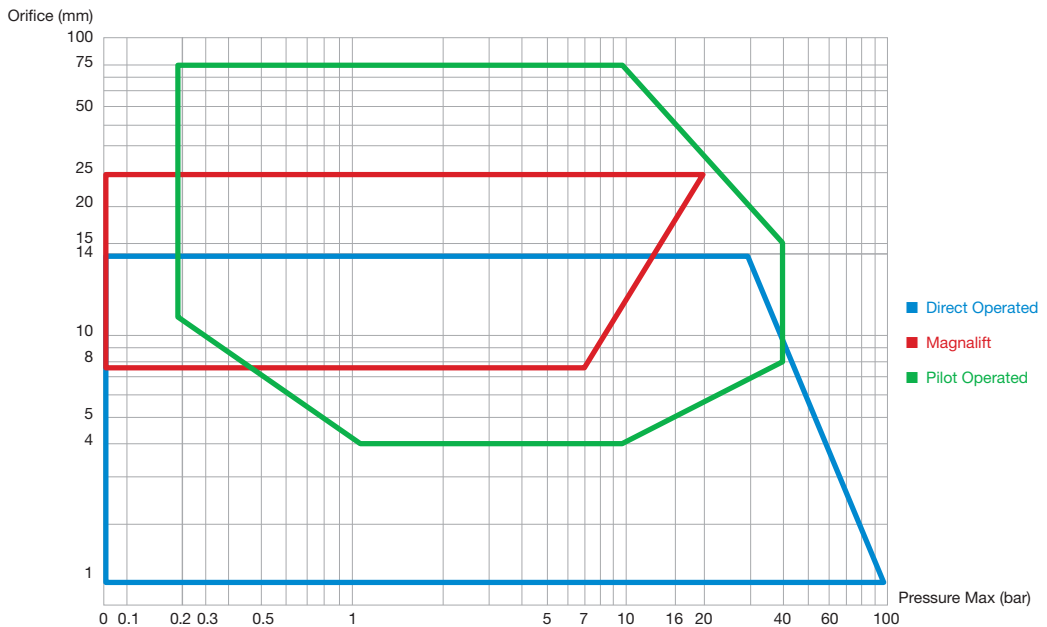

Areas of operation of Parker solenoid valves.

## SIZING SOLENOID VALVES

The correct choice of solenoid valve is essential as it determines the regulation and performance required for practical application on a system. In order to decide on the exact type of solenoid valve, various parameters have to be known.

However the calculation method, based on the flow coefficient  $K_v$ , has proved highly practical as it can be determined on the basis of:

- Required flow rate
- Type of fluid and relative viscosity
- Flow resistance
- Specific gravity and temperature

This flow coefficient  $K_v$  is determined as defined in the VDI/VDE 2173 standards. It represents the flow of water in  $m^3/h$  or  $L/min$  with a temperature from 5 to  $30^\circ C$  which passes through the solenoid valve with a pressure drop of 1 bar.

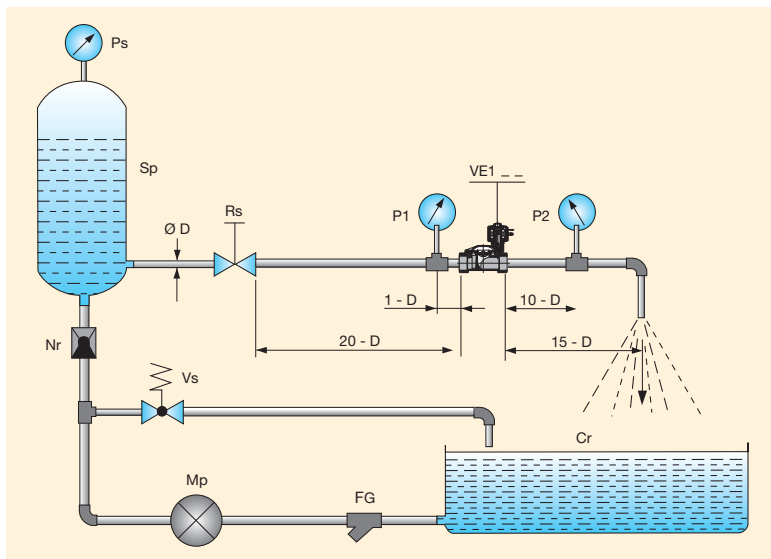

FG = Grid Filter    Mp = Pump    Vs = Safety Valve    Nr = Check Valve    Sp = Pressure Tank    Ps = Static Pressure Manometer

**Note:**

The flow coefficient used in the USA is known as  $C_v$  and represents the water flow rate in US gallons per minute with a pressure drop  $\Delta P$  of 1 psi.

To convert  $C_v$  in  $K_v$  and vice versa use:

$$1 K_v = 0.862 C_v$$

$$1 C_v = 1.16 K_v$$

After existing conditions have been converted into this factor  $K_v$ , the type of valve is found by referring to the pages in the related sections in this catalogue.

**Parameters used for selecting the solenoid valve are in the table next page.**

Consult conversion tables of the various units of measurement as defined by the ISO (International Standards Organisation) - I.S. (International System) set out in this catalogue.

## FLOW AND PRESSURE RANGES

### Pressure

symbol (P)  
unit of measurement [bar]  
Working pressure

### Pressure drop

symbol (ΔP)  
unit of measurement [bar]  
Pressure difference between inlet (P<sub>1</sub>) and outlet (P<sub>2</sub>) of the solenoid valve when a medium is flowing through the valve (ΔP = P<sub>1</sub> - P<sub>2</sub>).

### Flow coefficient

symbol (Kv)  
unit of measurement [l/min]

### Specific gravity of the medium

symbol (γ)  
unit of measurement [Kg/dm<sup>3</sup>]

### Temperature of the medium

symbol (t)  
unit of measurement [°C]

### Flow rate

- for liquids  
symbol (Q)  
unit of measurement [l/min]
- for gases  
symbol (Qn)  
unit of measurement [Nm<sup>3</sup>/h]
- for steam  
symbol (Qv)  
unit of measurement [Kg/h]

### Specific volume

symbol (Vs)  
unit of measurement [m<sup>3</sup>/Kg]

### a) Solenoid valves for liquids:

**Flow rate:**  $Q = K_v \cdot \sqrt{\frac{\Delta P}{\gamma}}$  where: Q = l/min  
ΔP = bar  
γ = Kg/dm<sup>3</sup>

**Flow coefficient:**  
 $K_v = Q \cdot \sqrt{\frac{\gamma}{\Delta P}}$

In the case of liquids with viscosity greater than 3°E (22 cStokes) the Kv is modified according to the formula:

$$K_{v_1} = K_v + C \quad C = \frac{\delta \cdot \sqrt{K_v}}{200 \cdot Q} + 1$$

where C is the viscosity correction factor calculated by means of the formula:

where:

δ = kinematic viscosity of the fluid expressed in centistokes

Kv = flow rate factor of the solenoid valve

Q = flow rate in l/min

### Pressure drop:

$$\Delta P = \gamma \cdot \left(\frac{Q}{K_v}\right)^2$$

### b) Solenoid valves for gases:

If  $\Delta P \leq 1/2 P_1$  use the following formulae:

**Flow rate:**  $Q_n = 514 \cdot K_v \cdot \sqrt{\frac{\Delta P \cdot P_2}{\gamma n \cdot (273 + t)}}$

where:  $Q_n = \text{Nm}^3/\text{h}$      $P_1 = \text{bar}$      $P_2 = \text{bar}$

**Flow coefficient:**  $K_v = \frac{Q_n}{514} \cdot \sqrt{\frac{(273+t) \cdot \gamma n}{\Delta P \cdot P_2}}$

$t = ^\circ\text{C}$   
 $\gamma n = \text{Kg}/\text{dm}^3$

**Pressure drop:**  $\Delta P = \frac{(273 + t) \cdot \gamma n}{P_2} \cdot \frac{Q_n^2}{(514 \cdot K_v)^2}$

If  $\Delta P > 1/2 P_1$  use the following formula:

$$Q_n = 757 \cdot K_v \cdot \sqrt{\frac{\Delta P \cdot P_2}{(273 + t) \cdot \gamma n}}$$

### c) Solenoid valves for steam:

If  $\Delta P \leq 1/2 P_1$  use the following formulae:

**Flow rate:**  $Q_v = 31,7 \cdot K_v \cdot \sqrt{\frac{\Delta P}{V_s}}$

where:  $Q_v = \text{Kg}/\text{h}$      $\Delta P = \text{bar}$      $V_s = \text{m}^3/\text{Kg}$

**Flow coefficient:**  $K_v = \frac{Q_v}{31,7} \cdot \sqrt{\frac{V_s}{\Delta P}}$

**Pressure drop:**  $\Delta P = V_s \cdot \frac{Q_v^2}{(31,7 \cdot K_v)^2}$

If  $\Delta P > 1/2 P_1$  use the following formula:

$$Q_v = 22,4 \cdot K_v \cdot \sqrt{\frac{P_1}{V_s}}$$

#### Notes:

1) Should the value  $\Delta P$  not be specified, use the following, which is based on experience:

- For liquids only in the case of free discharge  $\Delta P = 90\%$  of the input pressure ( $P_1$ ).
- For gases never use a  $\Delta P$  of more than 50% of the absolute inlet pressure, since the excessive pressure drop may cause an irregular flow rate. In most cases,  $\Delta P$  can be considered as 10% of the input pressure.

2) Specific volume value ( $V_s$ ) for dry saturated steam, see the table in diagram 3.



**TECHNICAL  
INFORMATION**

# FLOW RATE FOR LIQUIDS

The liquid flow through a pipe or a valve is given by:

$$Q = K_v \cdot \sqrt{\frac{\Delta P}{\gamma}}$$

- Where
- Q** = Flow [l/min]
  - ΔP** = Differential Pressure [bar]
  - γ** = Density of the fluid [kg/dm<sup>3</sup>]  
(water γ = 1 [kg/dm<sup>3</sup>])
  - kv** = Flow Factor [l/min ]

### Flow factor kv:

The kv flow factor of a valve is defined as the flow rate of water in litres per minute with a pressure drop of 1 bar across the valve. Valve manufacturers use different definitions for kv. It may be expressed in l/h or m<sup>3</sup>/h. Care should therefore be taken when comparing values.

### Maximum flow rate Qmax.

For particular 2-way valves the maximum flow must be limited for reasons of mechanical resistance and durability. A very high flow velocity may dislocate a poppet sealing or a diaphragm. Maximum flow rates are indicated in the catalogue.

**Flow factors**

<b>Kv</b> l/min	<b>KV</b> m <sup>3</sup> /h	<b>Qn</b> l/min
--------------------	--------------------------------	--------------------

## NORMALLY CLOSED

Port size	Orifice Ø	Flow factors			Operating Pressure Differential Max(MOPD)			Fluid Temp.		Seat Seal	Parker LUCIFER® Valves			Power		Coil Group	Dwg. No.
		Kv l/min	KV m <sup>3</sup> /h	Qn l/min	Min	Max	AC bar	DC bar	Min		Max	Valve Ref.	Housing Ref.	Coil Ref.	AC W		
BSP	mm				bar	bar	bar	°C	°C								



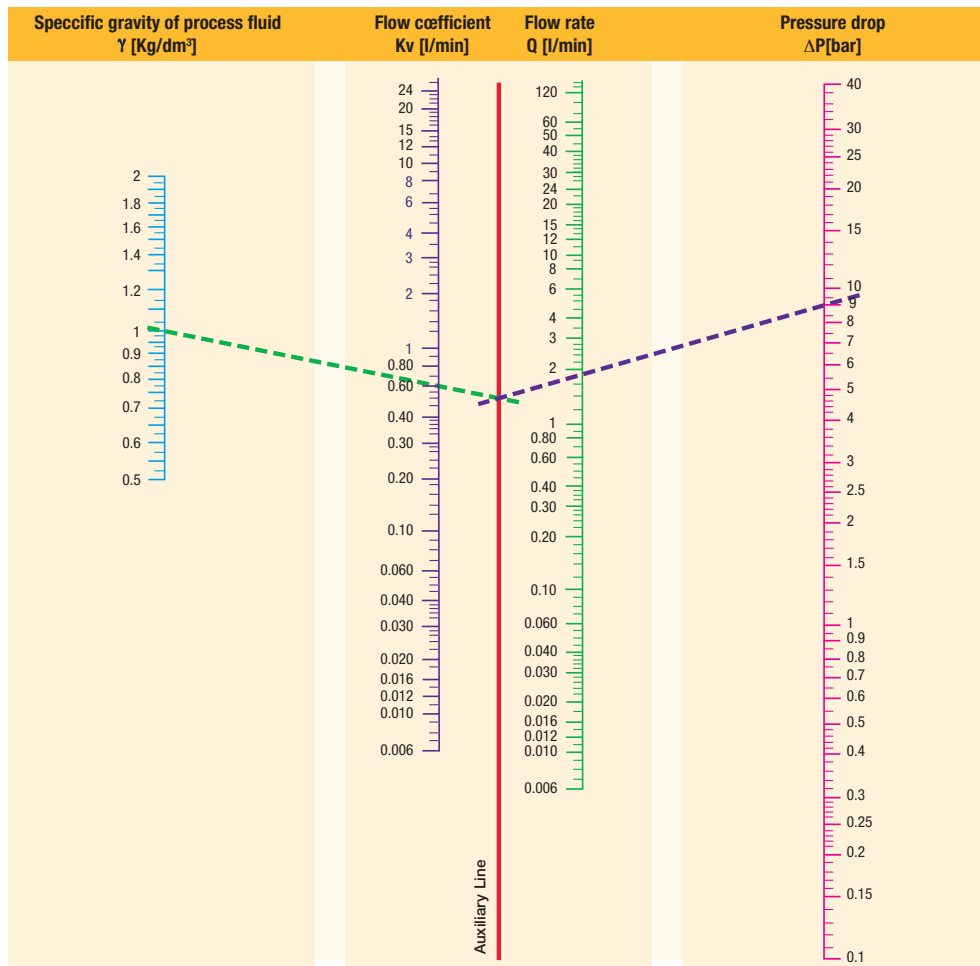

Monogram for liquid flow calculation

Specific gravity of the most common fluids ( $\gamma = \text{Kg/dm}^3$ ) - ( $t = 15^\circ\text{C}$ - $P = 760 \text{ mm Hg}$ )			
Acetone	0.76	Benzenol	0.90
Water	1.00	Beer	1.02
Sea water	1.02	Hexane	0.66
Ethyl alcohol	0.79	Ethane	0.68
Methyl alcohol	0.81	Diesel oil	0.70
Petrol	0.68	Milk	1.03
		Naphtha	0.76
		Pentane	0.63
		Vegetable oil	0.92
		Hydraulic oil	0.92
		Wine	0.95



## FLOW RATE FOR GASES

The gas flow through a valve is given by:

$$Q = C \cdot P_1 \cdot k_T \cdot \omega \cdot \gamma_{\text{air}} / \gamma_{\text{gas}}$$

Where

- Q** = Flow Rate [**dm<sup>3</sup>/s**]
- C** = Conductance [**dm<sup>3</sup>/s.bar**]
- P<sub>1</sub>** = Inlet Pressure [**bar abs**]
- γ** = Specific Weight [**Kg/dm<sup>3</sup>**]
- k<sub>T</sub>** = Temperature Correction Factor

$$\omega = \sqrt{1 - \frac{P_2/P_1 - b}{1 - b}}$$

$$k_T = \sqrt{\frac{293}{273 + \text{Temp. } ^\circ\text{C}}}$$

### Nominal Flow Q<sub>n</sub>:

Calculations can be made with specific flow factors based on the CETOP RP 50P standard. For practical purposes and ease of valve selection the catalogue shows the nominal flow Q<sub>n</sub>. The nominal flow Q<sub>n</sub> is defined as the flow rate (L/min) of air across the valve when the inlet pressure P<sub>1</sub> = 6 bar and the pressure drop ΔP = 1 bar.

#### N.B.

The values of the flow factors and flow rates mentioned in catalogues are subject to +/-15% tolerances.

### Pneumatic application: $\gamma_{\text{air}} / \gamma_{\text{gas}} = 1$

- a) **Choked flow conditions**  $P_2 \leq b \cdot P_1$   
in this case  $\omega = 1 \rightarrow Q = C \cdot P_1 \cdot k_T$
- b) **Free flow conditions**  $P_2 > b \cdot P_1$   
in this case  $\rightarrow Q = C \cdot P_1 \cdot k_T \cdot \omega$

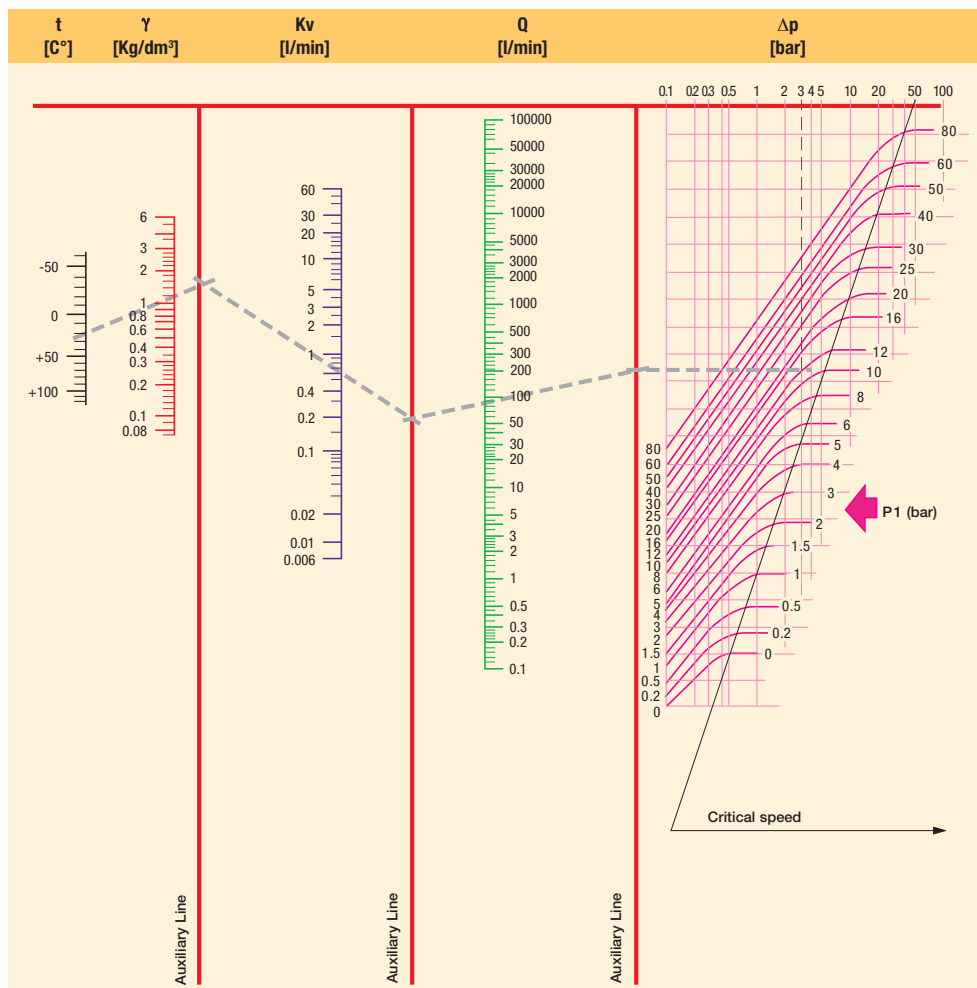

t = Fluid Temperature     $\gamma$ N = Specific Gravity    Kv = Flow Coefficient    Qn = Flow Rate     $\Delta p$  = Pressure Drop    P<sub>1</sub> = Inlet Pressure

**Specific gravity of the most common gases ( $\gamma = \text{Kg/m}^3$ ) - (t = 0°C - P = 760mm Hg)**

Acetylene	1.176	Helium	0.179	Natural gas	0.723
Carbon dioxide	1.965	Ethane	1.035	Methane	0.722
Air	1.293	Ethylene	1.259	Carbon monoxide	1.250
Argon	1.780	Hydrogen	0.089	Oxygen	1.429
Nitrogen	1.255			Propane	1.520
Butane	2.000			Steam	0.805

# TECHNICAL INFORMATION

## Diagram 3 for Dry Saturated Steam

## Steam (Dry Saturated) Data

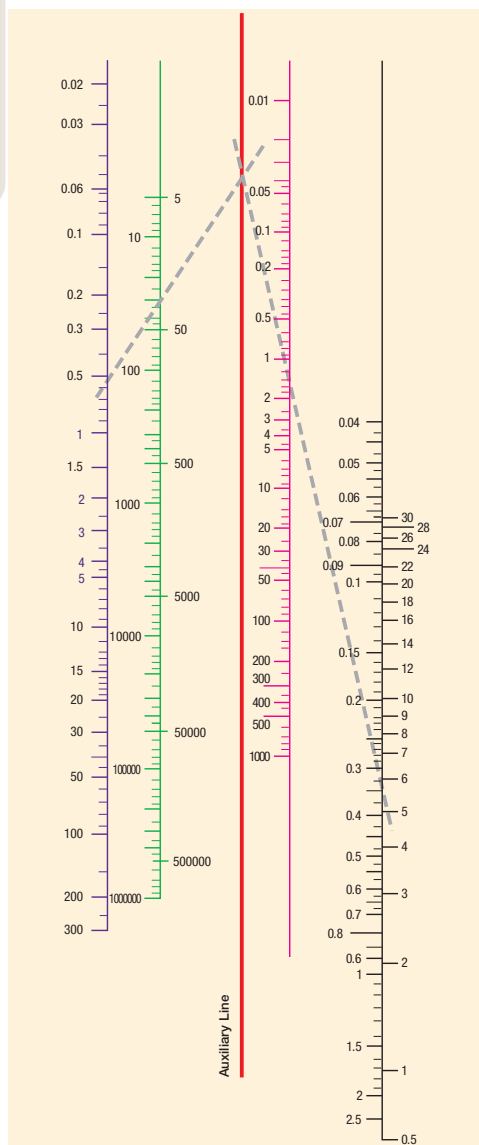

$P_2$ bar	Temp. °C	$V_s$ m <sup>3</sup> /Kg	$P_2$ bar	Temp. °C	$V_s$ m <sup>3</sup> /Kg
0.01	6.6	131.600	10.00	179.0	0.200
0.02	17.1	68.300	110.00	183.2	0.181
0.03	23.7	46.500	120.00	187.1	0.176
0.04	28.6	35.500	13.00	190.7	0.155
0.05	32.5	28.700	14.00	194.1	0.144
0.06	35.8	24.200	15.00	197.4	0.135
0.08	41.1	18.500	16.00	200.4	0.126
0.10	45.4	15.000	17.00	203.4	0.119
0.20	59.7	7.800	18.00	206.2	0.113
0.30	68.7	5.330	19.00	208.8	0.107
0.40	75.4	4.070	20.00	211.4	0.102
0.50	80.9	3.300	22.00	216.2	0.093
0.60	85.5	2.790	24.00	220.8	0.085
0.70	89.5	2.410	26.00	225.0	0.079
0.80	93.0	2.130	28.00	229.0	0.073
0.90	96.2	1.910	30.00	232.8	0.068
1.00	99.1	1.730	32.00	236.4	0.064
1.50	110.8	1.180	34.00	239.8	0.060
2.00	119.6	0.900	36.00	243.1	0.057
2.50	126.8	0.730	38.00	246.2	0.053
3.00	132.9	0.620	40.00	249.2	0.051
3.50	138.2	0.530	45.00	256.2	0.045
4.00	142.9	0.470	50.00	262.7	0.040
4.50	147.2	0.420	55.00	268.7	0.036
5.00	151.1	0.380	60.00	274.3	0.033
5.50	154.7	0.350	65.00	279.6	0.030
6.00	158.1	0.320	70.00	284.5	0.028
6.50	161.2	0.300	80.00	293.6	0.024
7.00	164.2	0.280	90.00	301.9	0.021
7.50	167.0	0.260	100.00	309.5	0.018
8.00	169.6	0.250	150.00	340.5	0.011
8.50	172.1	0.230	200.00	364.2	0.006
9.00	174.5	0.220	225.00	374.0	0.003
9.50	176.8	0.210			

$K_v$  = Flow Coefficient

$Q_v$  = Flow Rate

$\Delta p$  = Pressure Drop

$V_s$  = Specific Volume

$P_2$  = Outlet Pressure



## VISCOSITY CONVERSION TABLE

Centistokes cStokes mm <sup>2</sup> /S	°Engler °E	Saybolt Universal Second SSU	Rewood Second N°1 SRW N°1
1	1	-	-
12	2	65	55
22	3	100	90
30	4	140	120
28	5	175	155
45	6	210	185
60	8	275	245
75	10	345	305
90	12	415	370
115	15	525	465
150	20	685	610
200	26	910	810
300	39	1 385	1 215
400	53	1 820	1 620
500	66	2 275	2 025
750	97	3 365	2 995
1 500	197	6 820	6 075

## OTHER USEFUL FORMULAS

### Formulas:

$$^{\circ}\text{C} = (^{\circ}\text{F} - 32) \times 5/9$$

$$^{\circ}\text{F} = (^{\circ}\text{C} \times 9/5) + 32$$

$$\text{m}^3/\text{h} = \text{l}/\text{min} \times 0.06$$

$$\text{l}/\text{min} = \text{m}^3/\text{h} \times 16,67$$

$$\text{m}^3/\text{sec} = \text{m}^3/\text{h} \times 2,778 \times 10^{-4}$$

$$\text{m}^3/\text{sec} = \text{l}/\text{min} \times 1,667 \times 10^{-5}$$

### Examples:

$$(167^{\circ}\text{F}-32) \times 5/9 = 75^{\circ}\text{C}$$

$$(30^{\circ}\text{C} \times 9/5) + 32 = 86^{\circ}\text{F}$$

$$100 \text{ l}/\text{min} \times 0.06 = 6 \text{ m}^3/\text{h}$$

$$9 \text{ m}^3/\text{h} \times 16,67 = 150 \text{ l}/\text{min}$$

$$18.000 \text{ m}^3/\text{h} \times 2.778 \times 10^{-4} = 5 \text{ m}^3/\text{sec}$$

$$479.904 \text{ l}/\text{min} \times 1.667 \times 10^{-5} = 8 \text{ m}^3/\text{sec}$$



## APPENDIX

### TABLE OF SUB-BASES FOR VALVES (Examples)

This table is showing examples of existing Sub-bases and possible Valves associations.  
For more detail see sub-bases drawings in the following pages.

Sub-Base Reference	488860.01 /02/.03 /04/.05	486162 /63/64	485635 /36/37	481168 /04/.06 /08/.10	481964.04 /06/.08/.10	485291	485290	XGSPG1 /XGSPG2
Drawing	1	2	3	4	5	6	7	8
Valve Reference								
131F4480	●							
131F4480		●						
131F46		●						
131F4650		●						
131M74	●							
131M74	●							
131M7450	●							
131M7450	●							
131M75	●							
131M7550	●							
132F43		●						
132F44		●						
132F46		●						
133F46		●						
133F4650		●						
2019F1								●
3019F1								●
301XGR								●
341F34			●					
341F3403			●					
341L11					●			
341L2190							●	
341L9101				●				
345F34			●					
347L11					●			
E131F26								
E131F43		●						
E131F4350		●						
E131F44		●						
E131F4450		●						
E133F43		●						
E133F4350		●						
E133F44		●						
E133F4450		●						
E331L21						●		

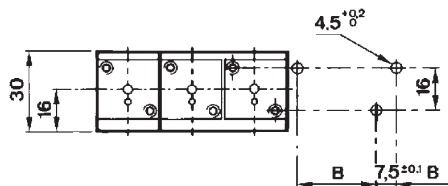
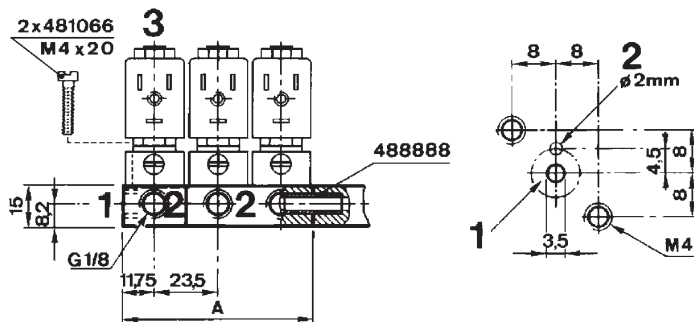
**TABLE OF SUB-BASES FOR VALVES (Examples)**

**488887**
**481067**

Quantity of Valves by Assembly	Reference Numbers	A mm	B mm	Weight g
1	488860-01	23.5	16.0 ± 0.1	25
2	488860-02	47.0	39.5 ± 0.1	45
3	488860-03	70.5	63.0 ± 0.1	70
4	488860-04	94.0	86.5 ± 0.1	120
5	488860-05	117.5	110.0 ± 0.1	120

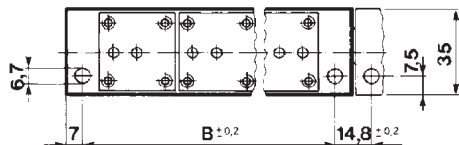
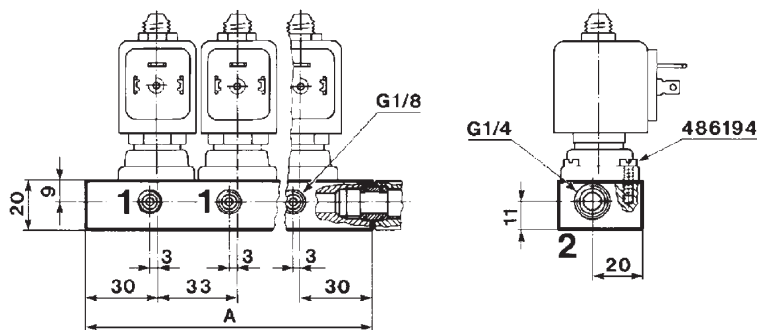
Drawing 1



Quantity of Valves by Assembly	Reference Numbers	A mm	B mm	Weight g
2	486162	93	79	150
3	486163	126	112	210
5	486164	192	178	420

Drawing 2



APPENDIX

TABLE OF SUB-BASES FOR VALVES (Examples)

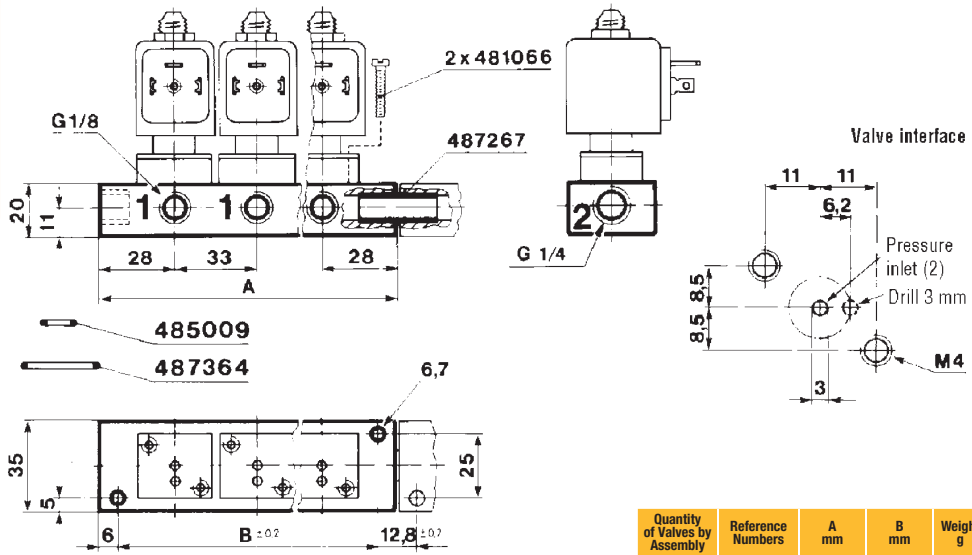

Drawing 3

Quantity of Valves by Assembly	Reference Numbers	A mm	B mm	Weight g
1	487165	56	44	85
2	487167	89	77	135
3	487169	188	176	300

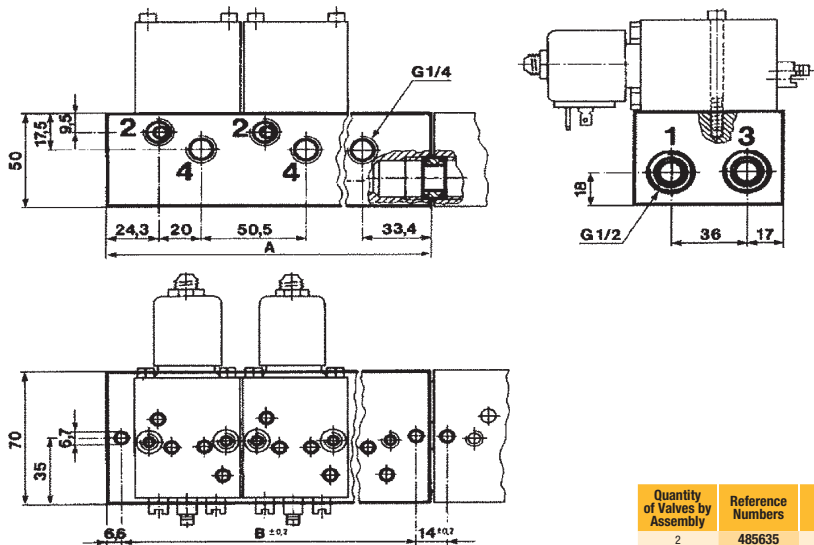

Drawing 4

Quantity of Valves by Assembly	Reference Numbers	A mm	B mm	Weight g
2	485635	128.2	115.0	1000
3	485636	178.7	165.5	1400
5	485637	279.7	266.5	2250

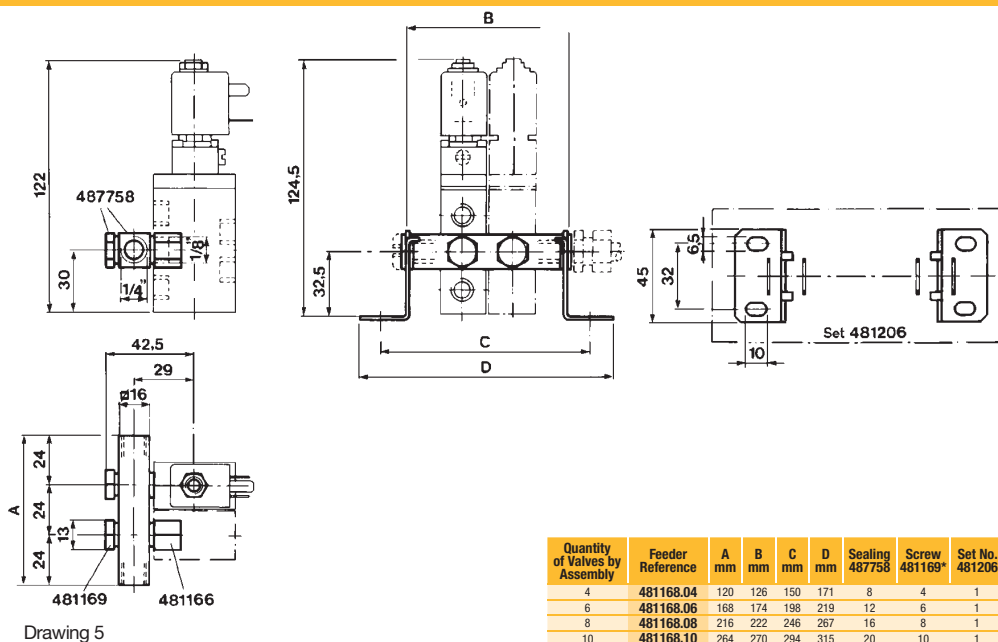

**TABLE OF SUB-BASES FOR VALVES (Examples)**

Drawing 5

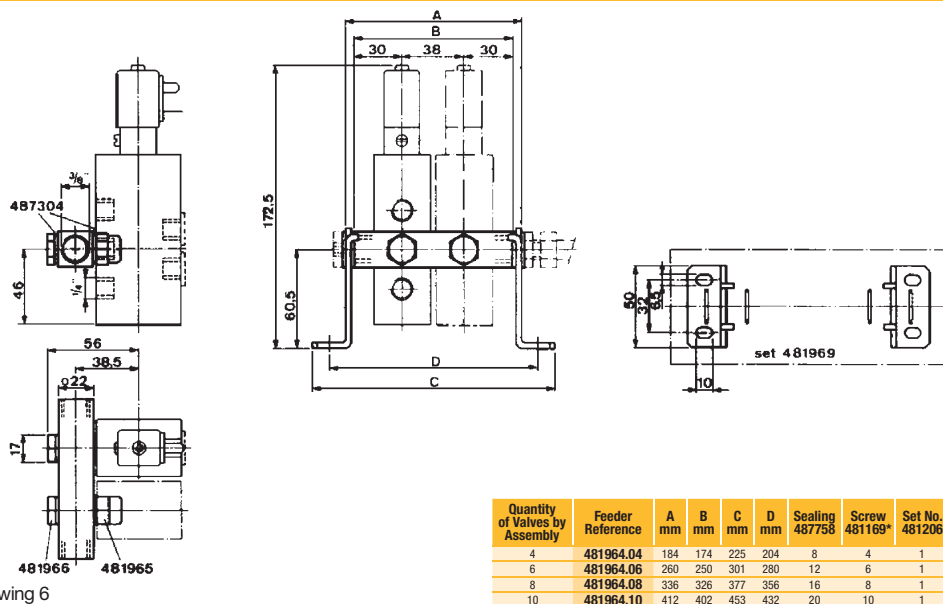

Drawing 6



APPENDIX

TABLE OF SUB-BASES FOR VALVES (Examples)

Sub-base 485291

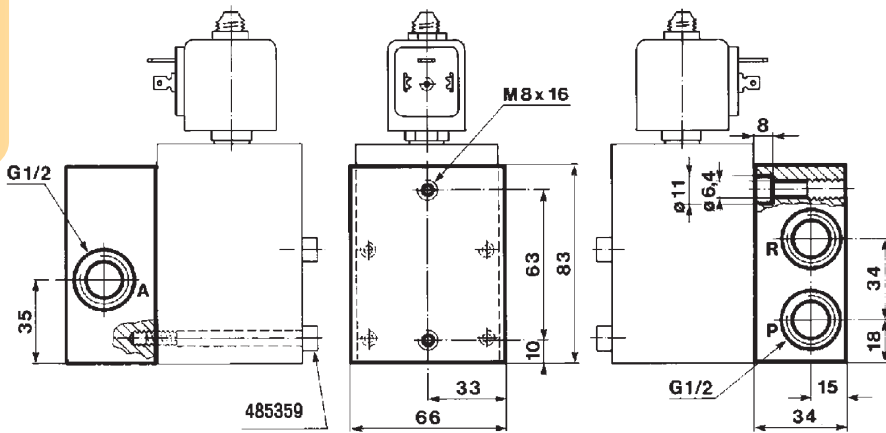

Drawing 7

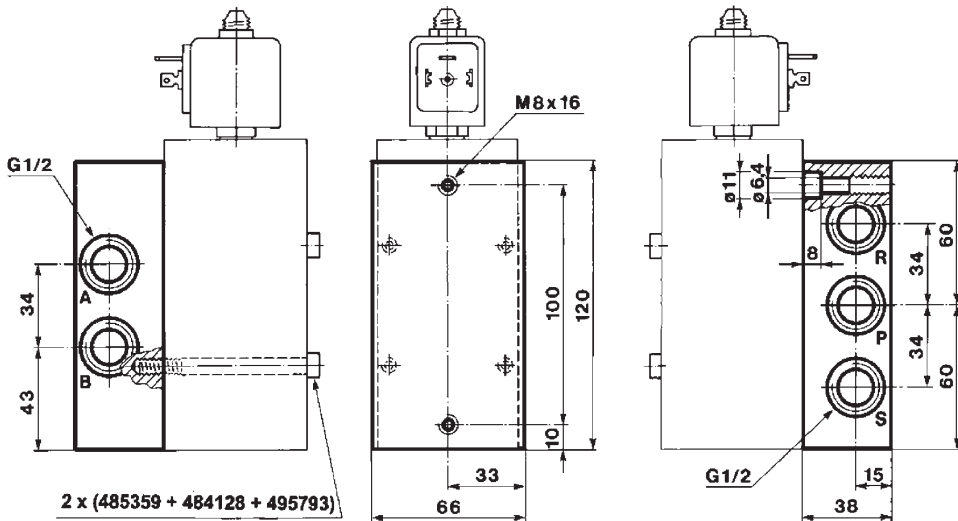

Drawing 8

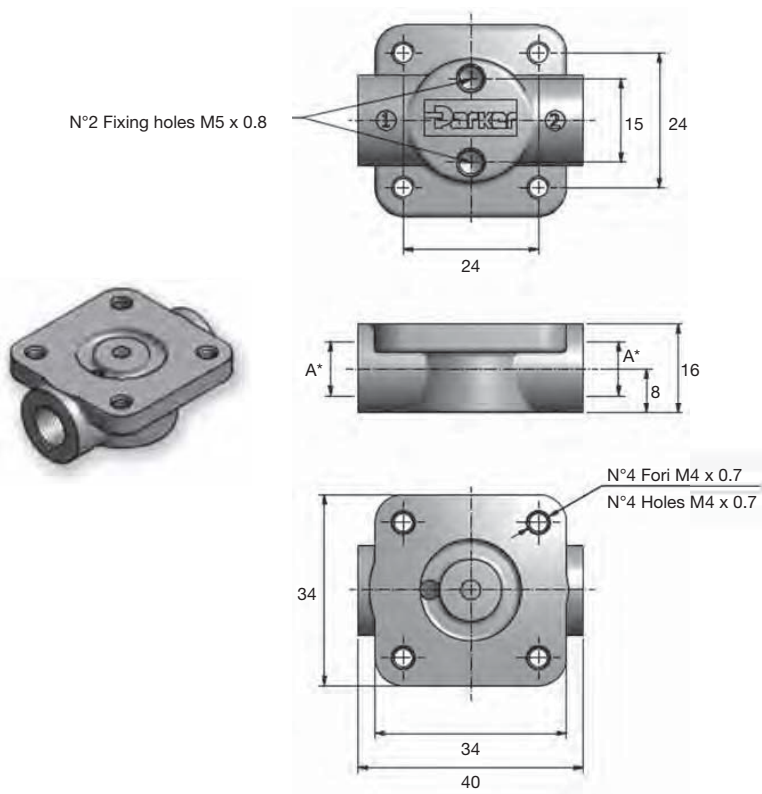

**TABLE OF SUB-BASES FOR VALVES (Examples)**

Drawing 9

Port	Kit Reference	To be used with	Box Quantity	Screws
1/8" G	XGSPG1	Any version	10	Included
1/4" G	XGSPG2	Any version	10	Included



# APPENDIX

## TABLE OF VOLTAGE CODES FOR COILS AND ELECTRICAL PARTS

This table is showing the most commonly used voltage codes, for other voltages, please ask us.

VOLTAGE CODES			C1	C2	N7	L8	C4	C5	C7	E6	P1	A5	OA	S5	P2	1P	6J	OP	P3	K8	
Coil	Group	Sub-Group	12 DC	24 DC	28 DC	30 DC	48 DC	110 DC	196 DC	220 DC	100/50	100/50-60	110/50	110-115/50	110-115/50 120/60	110/50-60	110-115/50-60	110-115/60	100/50-115/60	110/50-120/60	115/60
481045	1.1	-	•	•			•	•						•							
481180	1.1	-	•	•				•						•							
481530	1.1	-	•	•																	
482605	1.1	-	•	•																	
482606	1.1	-	•	•			•	•						•				•			
483590	1.1	-	•	•										•							
488143	1.1	-									•										
488980	1.1	-	•	•			•	•			•			•				•			
492912	1.1	-		•																	
492919	1.1	-		•																	
495865	1.1	-		•			•							•				•			
496131	1.2	-	•	•			•	•							•						•
496482	1.2	-	•	•			•	•							•						•
496637	1.2	-	•	•			•	•							•						•
WB4.5	1.3	-								•	•									•	•
WB5.0	1.3	-	•	•				•													
WB8.0	1.3	-																		•	•
481000	2.0	2.1	•	•			•	•		•				•				•			
481865	2.0	2.1	•	•			•	•						•							•
482635	2.0	2.1													•						
482725	2.0	2.1	•	•				•						•							•
483371	2.0	2.1	•	•			•	•		•				•				•			
483510	2.0	2.1													•						
483520	2.0	2.1													•						
485100	2.0	2.1		•						•				•							
488553	2.0	2.1									•			•							
488947	2.0	2.1									•			•							
491514	2.0	2.1	•	•		•														•	
492070	2.0	2.1	•	•			•	•							•						
492190	2.0	2.1	•	•			•	•		•					•						
492453	2.0	2.1	•	•			•	•						•							
492670	2.0	2.1	•	•			•	•						•							
492726	2.0	2.1		•																	
493640	2.0	2.1		•			•							•						•	
494040	2.0	2.1		•						•				•							•
495870	2.0	2.1		•			•	•						•							
495905	2.0	2.1		•			•	•						•							•
496081	2.0	2.1	•	•											•						
496082	2.0	2.1	•	•											•						
496110	2.0	2.1													•					•	
HZ10	2.0	2.1																			•
481044	2.0	2.2												•					•		
483816	2.0	2.2	•	•																	
486265	2.0	2.2	•	•			•							•					•		
492425	2.0	2.2	•	•										•							
492727	2.0	2.2	•	•																	
495880	2.0	2.2		•										•							
496155	2.0	2.2		•			•							•							
HZ11	2.0	2.2	•	•			•													•	
482730	3.0	-		•			•							•							•
482735	3.0	-		•			•														
495875	3.0	2.1		•																	





# APPENDIX

## TABLE OF VOLTAGE CODES FOR COILS AND ELECTRICAL PARTS

This table is showing the most commonly used voltage codes, for other voltages, please ask us.

VOLTAGE CODES			C1	C2	N7	L8	C4	C5	C7	E6	P1	A5	OA	S5	P2	1P	6J	OP	P3	K8		
Coil	Group	Sub-Group	12 DC	24 DC	28 DC	30 DC	48 DC	110 DC	196 DC	220 DC	100/50	100/50-60	110/50	110-115/50	110-115/50 120/60	110/50-60	110-115/50-60	110-115/60	100/50-115/60	110/50-120/60	115/60	
484990	4.0	-																				
485400	4.0	-	•	•			•	•														
495915	4.0	-		•			•															
482740	6.0	-					•	•														
482745	6.0	-		•																		
495900	6.0	-	•	•			•	•														
496125	6.0	-		•			•	•														•
483580.01	7.0	-			•																	
488650.01	7.0	-			•																	
488660.01	7.0	-			•																	
488670.01	7.0	-			•																	
490885	7.0	-				•																
490890	7.0	-			•	•																
495910	8.0	-			•																	
492210	9.0	-		•																		
492965.01	9.0	-			•																	
496565	9.0	-			•																	
492300	10.1	-	•	•			•	•			•					•						
492310	10.1	-	•	•			•	•		•						•						
496560	10.1	-		•			•	•								•						
496800	10.1	-		•			•	•								•						
496800.02	10.1	-		•			•	•								•						
496895	10.1	-		•			•	•								•						
496555	10.2	-		•			•	•								•						
496700	10.2	-		•			•	•								•						
496700.02	10.2	-		•			•	•								•						
497105	10.3	-	•	•			•	•														
483270	11.0	-	•	•			•	•														
483270.02	11.0	-	•	•			•	•														
492335	12.0	-				•																
482870.01	12.0	-			•																	
495294	13.0	-	•	•																		
496193	13.0	-	•	•																		
483824	14.1	-																				
483764	14.2	-																				
483541	14.3	-																				
YB09	20.1	-																•				•
YB12	20.1	-	•	•																		
ZB09	20.1	-	•	•				•				•					•					•
ZB12	20.1	-	•	•			•	•														
ZB14	20.2	-										•										•
ZB16	20.2	-	•	•				•														
ZH14	20.2	-																				•
ZH16	20.2	-	•	•																		
JB14	21.0	-																				
JB16	21.0	-	•	•					•													
KH09	22.0	-																				
KP10	22.0	-	•	•																		
KT09	22.0	-																				
XT09	23.0	-												•								
D4	24.0	-		•																		•
D5	24.0	-		•																		•
LA	24.0	-		•									•									
LB-LC	24.0	-		•																		•
XS03	24.0	-																				•





# APPENDIX

## INDEX BY COIL REFERENCE

Coil Reference	Coil Group	Designation	Power DC Pn (W)	Power AC Pn (W)	Ambient Temperature	UL	Degree of Protection	ATEX or NEMA 4X Protection (Gas)	Page
481000	2.0/2.1	Coil with screw terminal, 40 mm	8.0	8.0	-40°C to +50°C	-	IP 44 to 67	-	474
481044	2.0/2.2	Coil with screw terminal High power, 40 mm	-	14.0	-40°C to +50°C	-	IP 44 to 67	-	475
481180	1.1	Coil for DIN plug connection, 22 mm	5.0	4.0	-40°C to +50°C	-	IP65	-	453
481865	2.0/2.1	Coil for DIN plug connection, 32 mm	9.0	8.0	-40°C to +50°C	-	IP65	-	446
482605	1.1	Explosion proof encapsulated electrical part "mb", 32 mm	5.0	4.0	-40°C to +65°C	-	IP65	II 2 G Ex mb IIC T4/T5	494
482606	1.1	Explosion proof encapsulated electrical part "mb", low power, 32 mm	2.5	2.0	-40°C to +65°C	-	IP65	II 2 G Ex mb IIC T4/T5	494
482730	3.0	Coil for DIN plug connection, reduced power, 32 mm	7.0	6.0	-40°C to +50°C	-	IP65	-	448
482740	6.0	Coil for DIN plug connection, low power, 32 mm	1.6	-	-40°C to +50°C	-	IP65	-	449
482870.01	12.0	Explosion proof intrinsically safe electrical part "ia", 50 mm	3.0	-	-40°C to +65°C	-	IP66	II 1 G Ex ia IIC T6	512
483270	11.0	Flame proof electrical part "db", 50 mm	8.0	8.0	-40°C to +80°C	-	IP66	II 2 G Ex db IIC T4/T5/T6	492
483371	2.0/2.1	Explosion proof increased safety electrical part "eb", 50 mm	8.0	8.0	-40°C to +65°C	-	IP67	II 2 G Ex eb IIC T4	504
483510	2.0/2.1	Coil for DIN plug connection, 32 mm	-	9.0	-40°C to +50°C	-	IP65	-	446
483520	2.0/2.1	Coil with screw terminal, double frequency, 40 mm	-	9.0	-40°C to +50°C	-	IP 44 to 67	-	474
483541	14.3	Coil with screw terminal, high temperature-high power, 40 mm	20.0	20.0	-40°C to +50°C	-	IP 44 to 67	-	478
483580.01	7.0	Explosion proof intrinsically safe electrical part "ia", 32 mm	3.0	-	-40°C to +55°C	-	IP65	II 1 G Ex ia IIC T6	508
483590	1.1	Coil for DIN plug connection, double frequency, 22 mm	-	3.0	-40°C to +50°C	-	IP65	-	455
483764	14.2	Coil for DIN plug connection, UL recognized	-	9.0	-40°C to +50°C	-	IP65	-	451
483816	2.2	Coil for DIN plug connection for Jet Valves, 32 mm	14.0	14.0	-40°C to +50°C	-	IP65	-	452
483824	14.1	Coil with screw terminal, high temperature-high power, 40 mm	19.0	19.0	-40°C to +50°C	-	IP 44 to 67	-	477
484990	4.0	Coil with screw terminal, bistable, for impulse applications, 40 mm	-	11.0	-40°C to +50°C	-	IP44	-	480
485100	2.0/2.1	Coil with screw terminal, high temperature, 40 mm	8.0	8.0	-40°C to +50°C	-	IP 44 to 67	-	476
485400	4.0	Coil with screw terminal, bistable, for impulse applications, 40 mm	13.0	-	-40°C to +50°C	-	IP44	-	480
486265	2.0/2.2	Coil with screw terminal, high temperature-high power, 40 mm	14.0	14.0	-40°C to +50°C	-	IP 44 to 67	-	476
488143	1.1	Coil for DIN plug connection, double frequency, 22 mm	-	2.5	-40°C to +50°C	-	IP65	-	456
488553	2.0/2.1	Coil with screw terminal, double frequency, H class, 40 mm	-	9.0	-40°C to +50°C	-	IP 44 to 67	-	479
488650.01	7.0	Explosion proof intrinsically safe electrical part "ia", 50 mm	0.3 to 3.0	-	-40°C to +65°C	-	IP66	II 1 G Ex ia IIC T6	513
488660.01	7.0	Explosion proof intrinsically safe electrical part "ia", 50 mm	3.0	-	-40°C to +65°C	-	IP67	II 1 G Ex ia IIC T6	514
488670.01	7.0	Explosion proof intrinsically safe electrical part "ia", 50 mm	0.3 to 3.0	-	-40°C to +65°C	-	IP65	II 1 G Ex ia IIC T6	515
488980	1.1	Coil for DIN plug connection, low power, 22 mm	2.5	2.0	-40°C to +50°C	-	IP65	-	453
490885	7.0	Explosion proof intrinsically safe electrical part, "NEMA", 50 mm	3.0	-	-40°C to +60°C	-	NEMA 4 - 4X	Cl. I, Div. I, Gr. A, B, C, D	513
490890	7.0	Explosion proof intrinsically safe electrical part, "NEMA", 50 mm	3.0	-	-40°C to +60°C	-	NEMA 4 - 4X	Cl. I, Div. I, Gr. A, B, C, D	514
491514	2.0/2.1	Coil for DIN plug connection, 32 mm, UL class F	-	11.0	-40°C to +50°C	●	IP65	-	450
492070	2.0/2.1	Explosion proof encapsulated electrical part "mb", with water proof metal housing, 50mm	8.0	9.0	-40°C to +65°C	-	IP67	II 2 G Ex mb IIC T4/T5	496
492190	2.0/2.1	Explosion proof increased safety and encapsulated electrical part "eb", 50 mm	9.0	11.0	-40°C to +75°C	-	IP66	II 2 G Ex eb mb IIC T3/T4	507
492210	9.0	Explosion proof increased safety and encapsulated electrical part "eb", "Booster", 50 mm	1.0 to 1.8	-	-40°C to +75°C	-	IP66	II 2 G Ex eb mb IIC T5/T6	506
492310	10.1	Explosion proof increased safety and encapsulated electrical part "eb", 50 mm	6.0	6.0	-40°C to +75°C	-	IP66	II 2 G Ex eb mb IIC T4/T5	505
492335	12.0	Explosion proof intrinsically safe electrical part, "NEMA", 50 mm	3.0	-	-40°C to +60°C	-	NEMA 4 - 4X	Cl. I, Div. I, Gr. A, B, C, D	512
492425	2.0/2.2	Coil for DIN plug connection, high temperature, 32 mm	14.0	14.0	-40°C to +50°C	-	IP65	-	447
492453	2.0/2.1	Coil for DIN plug connection, high temperature, 32 mm	9.0	8.0	-40°C to +50°C	-	IP65	-	447
492670	2.0/2.1	Explosion proof encapsulated electrical part "mb", 32 mm	9.0	8.0	-40°C to +50°C	-	IP65	II 2 G Ex mb IIC T4	495
492912	1.1	Coil for DIN plug connection, 22 mm, UL	4.0	3.0	-40°C to +50°C	●	IP65	-	454
492965.01	9.0	Explosion proof intrinsically safe electrical part "ia", "Booster", 50 mm	0.3 to 2.3	-	-40°C to +65°C	-	IP66	II 1 G Ex ia IIC T6	511
493640	2.0/2.1	Flame proof encapsulated electrical part "db mb", double frequency	8.0	8.0	-40°C to +75°C	-	IP65	II 2 G Ex db mb IIC T4/T5	503
494040	2.0/2.1	Explosion proof increased safety electrical part "eb", 50 mm	8.0	8.0	-40°C to +90°C	-	IP67	II 2 G Ex eb IIC T3/T4	504
495294	13.0	Coil with ISO-DIN connector, 12-24VDC for transportation applications, 32 mm	9.0	-	-40°C to +120°C	-	IP69K	-	481
495865	1.1	Explosion proof electrical part "nAc nCc", low power, 22 mm	2.5	2.0	-40°C to +50°C	-	IP65	II 3 G Ex nAc nCc IIC T5	484
495870	2.0/2.1	Explosion proof electrical part "nAc nCc", 32 mm	9.0	8.0	-40°C to +50°C	-	IP65	II 3 G Ex nAc nCc IIC T3/T4	486



## INDEX BY COIL REFERENCE

Coil Reference	Coil Group	Designation	Power DC Pn (W)	Power AC Pn (W)	Ambient Temperature	UL	Degree of Protection	ATEX or NEMA 4X Protection (Gas)	Page
495875	3.0	Explosion proof electrical part "nAc nCc", 32 mm	7.0	6.0	-40°C to +50°C	-	IP65	II 3 G Ex nAc nCc IIC T3/T4	488
495880	2.0/2.2	Explosion proof electrical part "nAc nCc", 32 mm	14.0	14.0	-40°C to +50°C	-	IP65	II 3 G Ex nAc nCc IIC T3	489
495900	6.0	Flame proof encapsulated electrical part "db mb", low power, 37 mm	2.0	2.5	-40°C to +65°C	-	IP67	II 2 G Ex db mb IIC T4 / T5/T6	499
495905	2.0/2.1	Flame proof encapsulated electrical part "db mb", 37 mm	8.0	8.0	-40°C to +65°C	-	IP67	II 2 G Ex db mb IIC T4	500
495910	8.0	Explosion proof intrinsically safe electrical part "ia", "booster", 37 mm	0.3 to 1.2	-	-40°C to +80°C	-	IP67	II 1 G Ex ia IIC T4/T5/T6	509
495915	4.0	Explosion proof increased safety electrical part "nAc nCc", 50 mm	13.0	11.0	-40°C to +65°C	-	IP67	II 3 G Ex nAc nCc IIC T3	490
496081	2.0/2.1	Coil with flying leads, IP 67, 32 mm	9.0	9.0	-40°C to +50°C	-	IP67	-	472
496082	2.0/2.2	Coil with flying leads, IP 67, 32 mm, UL	16.0	13.0-14.0	-40°C to +120°C	●	IP67	-	473
496110	2.0/2.1	Explosion proof electrical part "nAc nCc", 32 mm	-	9.0	-40°C to +50°C	-	IP65	II 3 G Ex nAc nCc IIC T3/T4	486
496125	6.0	Explosion proof electrical part "nAc nCc", low power, 32 mm	1.6	-	-40°C to +50°C	-	IP65	II 3 G Ex nAc nCc IIC T5/T6	487
496131	1.2	Coil for DIN plug connection, double frequency, 22 mm	3.0	3.0	-40°C to +50°C	-	IP65	-	457
496155	2.0/2.2	Explosion proof increased safety electrical part "nAc nCc", 50 mm	14.0	14.0	-40°C to +65°C	-	IP67	II 3 G Ex nAc nCc IIC T3	491
496193	13.0	Coil with ISO-DIN connector, 12-24VDC, for transportation applications, 32 mm	9.0	-	-40°C to +120°C	-	IP69K	-	481
496482	1.2	Coil for DIN plug connection, double frequency coil, 22 mm	3.0	3.0	-40°C to +50°C	-	IP65	-	458
496555	10.2	Flame proof encapsulated electrical part "db mb", 37 mm	6.0	6.0	-40°C to +65°C	-	IP67	II 2 G Ex db mb IIC T4/T5/T6	501
496560	10.1	Flame proof encapsulated electrical part "db mb", 37 mm	8.0	8.0	-40°C to +65°C	-	IP67	II 2 G Ex db mb IIC T4	501
496565	9.0	Explosion proof intrinsically safe electrical part "ia", "Booster", 37 mm	0.77 to 2.58	-	-40°C to +80°C	-	IP67	II 1 G Ex ia IIC T4/T5/T6	510
496637	1.2	Explosion proof electrical part "nAc nCc", double frequency, 22 mm	3.0	3.0	-20°C to +50°C	-	IP65	II 3 D Ex TC IIC T 95°C	485
496700	10.2	Flame proof encapsulated electrical part "db mb", 37 mm	6.0	6.0	-40°C to +65°C	-	IP67	II 2 G Ex db mb IIC T4 / T5 / T6	502
496800	10.1	Flame proof encapsulated electrical part "db mb", 37 mm	8.0	8.0	-40°C to +65°C	-	IP67	II 2 G Ex db mb IIC T4	502
496895	10.1	Coil for DIN plug connection for oil and gas, 37 mm	8.0	8.0	-40°C to +50°C	-	IP65	-	468
497105	10.3	Flame proof stainless steel electrical part "db"	8.0	8.0	-50°C to +80°C	-	IP66	II 2 G Ex db IIC T4/T5/T6	493
D4	24.0	Coil for DIN plug connection, 32 mm, UL	16.0	13.0	-40°C to +50°C	●	IP65	-	465
D5	24.0	Coil for DIN plug connection, 32 mm	9.0	8.0	-40°C to +50°C	-	IP65	-	466
HZ10	2.0/2.1	Explosion proof encapsulated electrical part "mb", double frequency	8.0	8.0	-40°C to +85°C	-	IP65	II 2 G Ex mb IIC T3/T4/T5	497
HZ11	2.0/2.2	Explosion proof encapsulated electrical part "mb", double frequency	14.0	14.0	-40°C to +85°C	-	IP65	II 2 G Ex mb IIC T3/T4/T5	498
JB14	21.0	Coil for DIN plug connection	16.0	-	-10°C to +50°C	-	IP65	-	462
JB16	21.0	Coil for DIN plug connection	-	14.0	-10°C to +50°C	-	IP65	-	462
KH09	22.0	Coil for DIN plug connection	-	9.0	-10°C to +80°C	-	IP65	-	463
KT09	22.0	Coil for DIN plug connection	-	9.0	-10°C to +50°C	-	IP65	-	463
KT10	22.0	Coil for DIN plug connection	10.0	-	-10°C to +50°C	-	IP65	-	463
LA	24.0	Coil with flying leads, IP67, 32 mm	9.0	9.0	-10°C to +50°C	-	IP67	-	470
LB-LC	24.0	Coil with flying leads, 32 mm, UL	16.0	13.0-14.0	-10°C to +50°C	●	IP67	-	471
WB4.5	1.3	Coil for DIN plug connection, 22 mm	-	4.5	-10°C to +50°C	-	IP65	-	459
WB4.5 UR	1.3	Coil for DIN plug connection, 22 mm	-	4.5	-10°C to +50°C	●	IP65	-	459
WB5.0	1.3	Coil for DIN plug connection, 22 mm	5.0	-	-10°C to +50°C	-	IP65	-	459
WB5.0 cURus	1.3	Coil for DIN plug connection, 22 mm	5.0	-	-10°C to +50°C	●	IP65	-	459
WB8.0	1.3	Coil for DIN plug connection, 22 mm	-	8.0	-10°C to +50°C	-	IP65	-	459
XS03	24.0	Coil for DIN plug connection	-	9.0	-40°C to +50°C	-	IP65	-	467
XT09	23.0	Coil for DIN plug connection	-	9.0	-10°C to +50°C	-	IP54	-	464
YB09	20.1	Coil with flying leads, IP67, UL for AC	-	9.0	-10°C to +50°C	●	IP67	-	469
YB12	20.1	Coil with flying leads, IP67	12.0	-	-10°C to +50°C	-	IP67	-	469
ZB09	20.0	Coil for DIN plug connection, UL for AC	-	9.0	-10°C to +50°C	●	IP65	-	460
ZB12	20.0	Coil for DIN plug connection	12.0	-	-10°C to +50°C	-	IP65	-	460
ZB14	20.2	Coil for DIN plug connection, high power - high temperature series	-	14.0	-10°C to +50°C	-	IP65	-	461
ZB16	20.2	Coil for DIN plug connection, high power - high temperature series	16.0	-	-10°C to +50°C	-	IP65	-	461
ZH14	20.2	Coil for DIN plug connection, high power - high temperature series	-	14.0	-10°C to +80°C	-	IP65	-	461
ZH16	20.2	Coil for DIN plug connection, high power - high temperature series	16.0	-	-10°C to +80°C	-	IP65	-	461

## APPENDIX

### INDEX BY COIL GROUP

Coil Group	Coil Reference	Designation	Power DC Pn (W)	Power AC Pn (W)	Ambient Temperature	UL	Degree of Protection	ATEX or NEMA 4X Protection (Gas)	Page
1.1	488980	Coil for DIN plug connection, low power, 22 mm	2.5	2.0	-40°C to +50°C	-	IP65	-	453
1.1	492912	Coil for DIN plug connection, UL 22 mm	4.0	3.0	-40°C to +50°C	●	IP65	-	454
1.1	481180	Coil for DIN plug connection, 22 mm	5.0	4.0	-40°C to +50°C	-	IP65	-	453
1.1	488143	Coil for DIN plug connection, double frequency, 22 mm	-	2.5	-40°C to +50°C	-	IP65	-	456
1.1	483590	Coil for DIN plug connection, double frequency, 22 mm	-	3.0	-40°C to +50°C	-	IP65	-	455
1.1	495865	Explosion proof electrical part "nAc nCc", low power, 22 mm	2.5	2.0	-40°C to +50°C	-	IP65	II 3 G Ex nAc nCc IIC T5	484
1.1	482606	Explosion proof encapsulated electrical part "mb", low power, 32 mm	2.5	2.0	-40°C to +65°C	-	IP65	II 2 G Ex mb IIC T4/T5	494
1.1	482605	Explosion proof encapsulated electrical part "mb", 32 mm	5.0	4.0	-40°C to +65°C	-	IP65	II 2 G Ex mb IIC T4/T5	494
1.2	496131	Coil for DIN plug connection, double frequency, 22 mm	3.0	3.0	-40°C to +50°C	-	IP65	-	457
1.2	496482	Coil for DIN plug connection, double frequency coil, 22 mm	3.0	3.0	-40°C to +50°C	-	IP65	-	458
1.2	496637	Explosion proof electrical part "nAc nCc", 22 mm, double frequency	3.0	3.0	-20°C to +50°C	-	IP65	II 3 D Ex tc IIC T 95°C	485
1.3	WB5.0	Coil for DIN plug connection, 22 mm	5.0	-	-10°C to +50°C	-	IP65	-	459
1.3	WB5.0 cURus	Coil for DIN plug connection, 22 mm	5.0	-	-10°C to +50°C	●	IP65	-	459
1.3	WB4.5	Coil for DIN plug connection, 22 mm	-	4.5	-10°C to +50°C	-	IP65	-	459
1.3	WB4.5 UR	Coil for DIN plug connection, 22 mm	-	4.5	-10°C to +50°C	●	IP65	-	459
1.3	WB8.0	Coil for DIN plug connection, 22 mm	-	8.0	-10°C to +50°C	-	IP65	-	459
2.0/2.1	481000	Coil with screw terminal, 40 mm	8.0	8.0	-40°C to +50°C	-	IP 44 to 67	-	474
2.0/2.1	485100	Coil with screw terminal, high temperature, 40 mm	8.0	8.0	-40°C to +50°C	-	IP 44 to 67	-	476
2.0/2.1	481865	Coil for DIN plug connection, 32 mm	9.0	8.0	-40°C to +50°C	-	IP65	-	446
2.0/2.1	492453	Coil for DIN plug connection, high temperature, 32 mm	9.0	8.0	-40°C to +50°C	-	IP65	-	447
2.0/2.1	496081	Coil with flying leads, IP 67, 32 mm	9.0	9.0	-10°C to +50°C	-	IP67	-	472
2.0/2.1	483510	Coil for DIN plug connection, 32 mm	-	9.0	-40°C to +50°C	-	IP65	-	446
2.0/2.1	483520	Coil with screw terminal, double frequency, 40 mm	-	9.0	-40°C to +50°C	-	IP 44 to 67	-	474
2.0/2.1	488553	Coil with screw terminal, double frequency, H class, 40 mm	-	9.0	-40°C to +50°C	-	IP 44 to 67	-	479
2.0/2.1	491514	Coil for DIN plug connection, 32 mm, UL	-	11.0	-40°C to +50°C	●	IP65	-	450
2.0/2.1	495870	Explosion proof electrical part "nAc nCc", 32 mm	9.0	8.0	-40°C to +50°C	-	IP65	II 3 G Ex nAc nCc IIC T3/T4	486
2.0/2.1	496110	Explosion proof electrical part "nAc nCc", 32 mm	-	9.0	-40°C to +50°C	-	IP65	II 3 G Ex nAc nCc IIC T3/T4	486
2.0/2.1	492670	Explosion proof encapsulated electrical part "mb", 32 mm	9.0	8.0	-40°C to +50°C	-	IP65	II 2 G Ex mb IIC T4	495
2.0/2.1	492070	Explosion proof encapsulated electrical part "mb", with water proof metal housing, 50 mm	8.0	9.0	-40°C to +65°C	-	IP67	II 2 G Ex mb IIC T4/T5	496
2.0/2.1	493640	Flame proof encapsulated electrical part "db mb", double frequency	8.0	8.0	-40°C to +75°C	-	IP65	II 2 G Ex db mb IIC T4/T5	503
2.0/2.1	495905	Flame proof encapsulated electrical part "db mb", 37 mm	8.0	8.0	-40°C to +65°C	-	IP67	II 2 G Ex db mb IIC T4	500
2.0/2.1	494040	Explosion proof increased safety electrical part "eb", 50 mm	8.0	8.0	-40°C to +90°C	-	IP67	II 2 G Ex eb IIC T3/T4	504
2.0/2.1	483371	Explosion proof increased safety electrical part "eb", 50 mm	8.0	8.0	-40°C to +65°C	-	IP67	II 2 G Ex eb IIC T4	504
2.0/2.1	492190	Explosion proof increased safety and encapsulated electrical part "eb", 50 mm	9.0	11.0	-40°C to +75°C	-	IP66	II 2 G Ex eb mb IIC T3/T4	507
2.0/2.1	HZ10	Explosion proof encapsulated electrical part "mb", double frequency	8.0	8.0	-40°C to +85°C	-	IP65	II 2 G Ex mb IIC T3/T4/T5	497
2.0/2.2	486265	Coil with screw terminal, high temperature-high power, 40 mm	14.0	14.0	-40°C to +50°C	-	IP 44 to 67	-	476
2.0/2.2	492425	Coil for DIN plug connection, high temperature, 32 mm	14.0	14.0	-40°C to +50°C	-	IP65	-	447
2.0/2.2	481044	Coil with screw terminal high power, 40 mm	-	14.0	-40°C to +50°C	-	IP 44 to 67	-	475
2.0/2.2	495880	Explosion proof electrical part "nAc nCc", 32 mm	14.0	14.0	-40°C to +50°C	-	IP65	II 3 G Ex nAc nCc IIC T3	489
2.0/2.2	496082	Coil with flying leads, IP 67, 32 mm, UL	16.0	13.0-14.0	-40°C to +120°C	●	IP67	-	473
2.0/2.2	496155	Explosion proof increased safety electrical part "nAc nCc", 50 mm	14.0	14.0	-40°C to +65°C	-	IP67	II 3 G Ex nAc nCc IIC T3	491
2.0/2.2	HZ11	Explosion proof encapsulated electrical part "mb", double frequency	14.0	14.0	-40°C to +85°C	-	IP65	II 2 G Ex mb IIC T3/T4/T5	498
2.2	483816	Coil for DIN plug connection for Jet Valves, 32 mm	14.0	14.0	-40°C to +50°C	-	IP65	-	452
3.0	482730	Coil for DIN plug connection, reduced power, 32 mm	7.0	6.0	-40°C to +50°C	-	IP65	-	448
3.0	495875	Explosion proof electrical part "nAc nCc", 32 mm	7.0	6.0	-40°C to +50°C	-	IP65	II 3 G Ex nAc nCc IIC T3/T4	488
4.0	485400	Coil with screw terminal, bistable, for impulse applications, 40 mm	13.0	-	-40°C to +50°C	-	IP44	-	480
4.0	484990	Coil with screw terminal, bistable, for impulse applications, 40 mm	-	11.0	-40°C to +50°C	-	IP44	-	480
4.0	495915	Explosion proof increased safety electrical part "nAc nCc", 50 mm	13.0	11.0	-40°C to +65°C	-	IP67	II 3 G Ex nAc nCc IIC T3	490



## INDEX BY COIL GROUP

Coil Group	Coil Reference	Designation	Power DC Pn (W)	Power AC Pn (W)	Ambient Temperature	UL	Degree of Protection	ATEX or NEMA 4X Protection (Gas)	Page
6.0	482740	Coil for DIN plug connection, low power, 32 mm	1.6	-	-40°C to +50°C	-	IP65	-	449
6.0	496125	Explosion proof electrical part "nAc nCc", low power, 32 mm	1.6	-	-40°C to +50°C	-	IP65	II 3 G Ex nAc nCc IIC T5/T6	487
6.0	495900	Flame proof encapsulated electrical part "db mb", low power, 37 mm	2.0	2.5	-40°C to +65°C	-	IP67	II 2 G Ex db mb IIC T4 / T5/T6	499
7.0	483580.01	Explosion proof intrinsically safe electrical part "ia", 32 mm	3.0	-	-40°C to +55°C	-	IP65	II 1 G Ex ia IIC T6	508
7.0	488660.01	Explosion proof intrinsically safe electrical part "ia", 50 mm	3.0	-	-40°C to +65°C	-	IP67	II 1 G Ex ia IIC T6	514
7.0	488650.01	Explosion proof intrinsically safe electrical part "ia", 50 mm	0.3 to 3.0	-	-40°C to +65°C	-	IP66	II 1 G Ex ia IIC T6	513
7.0	488670.01	Explosion proof intrinsically safe electrical part "ia", 50 mm	0.3 to 3.0	-	-40°C to +65°C	-	IP65	II 1 G Ex ia IIC T6	515
7.0	490885	Explosion proof intrinsically safe electrical part, "NEMA", 50 mm	3.0	-	-40°C to +60°C	-	NEMA 4 - 4X	Cl. I, Div1, Gr. A, B, C, D	513
7.0	490890	Explosion proof intrinsically safe electrical part, "NEMA", 50 mm	3.0	-	-40°C to +60°C	-	NEMA 4 - 4X	Cl. I, Div1, Gr. A, B, C, D	514
8.0	495910	Explosion proof intrinsically safe electrical part "ia", "booster", 37 mm	0.3 to 1.2.0	-	-40°C to +80°C	-	IP67	II 1 G Ex ia IIC T4/T5/T6	509
9.0	492210	Explosion proof increased safety and encapsulated electrical part "eb", "Booster", 50 mm	1.0 to 1.8	-	-40°C to +75°C	-	IP66	II 2 G Ex eb mb IIC T5/T6	506
9.0	496565	Explosion proof intrinsically safe electrical part "ia", "Booster", 37 mm	0.77 to 2.58	-	-40°C to +80°C	-	IP67	II 1 G Ex ia IIC T4/T5/T6	510
9.0	492965.01	Explosion proof intrinsically safe electrical part "ia", "Booster", 50 mm	0.3 to 2.3	-	-40°C to +65°C	-	IP66	II 1 G Ex ia IIC T6	511
10.1	496895	Coil for DIN plug connection for oil and gas, 37 mm	8.0	8.0	-40°C to +50°C	-	IP65	-	468
10.1	496560	Flame proof encapsulated electrical part "db mb", 37 mm	8.0	8.0	-40°C to +65°C	-	IP67	II 2 G Ex db mb IIC T4	501
10.1	496800	Flame proof encapsulated electrical part "db mb", 37 mm	8.0	8.0	-40°C to +65°C	-	IP67	II 2 G Ex db mb IIC T4	502
10.1	492310	Explosion proof increased safety and encapsulated electrical part "eb", 50 mm	6.0	6.0	-40°C to +75°C	-	IP66	II 2 GD Ex eb mb II T4/T5	505
10.2	496555	Flame proof encapsulated electrical part "db mb", 37 mm	6.0	6.0	-40°C to +65°C	-	IP67	II 2 G Ex db mb IIC T4/T5/T6	501
10.2	496700	Flame proof encapsulated electrical part "db mb", 37 mm	6.0	6.0	-40°C to +65°C	-	IP67	II 2 G Ex db mb IIC T4/T5/T6	502
10.3	497105	Flame proof electrical part "d"	8.0	8.0	-50°C to +80°C	-	IP66	II 2 G Ex db IIC T4/T5/T6	493
11.0	483270	Flame proof electrical part "db", 50 mm	8.0	8.0	-40°C to +80°C	-	IP66	II 2 G Ex db IIC T4/T5/T6	492
12.0	482870.01	Explosion proof intrinsically safe electrical part "ia", 50 mm	3.0	-	-40°C to +65°C	-	IP66	II 1 G Ex ia IIC T6	512
12.0	492335	Explosion proof intrinsically safe electrical part, "NEMA", 50 mm	3.0	-	-40°C to +60°C	-	NEMA 4 - 4X	Cl. I, Div1, Gr. A, B, C, D	512
13.0	495294	Coil with ISO-DIN connector, 12-24VDC for transportation applications, 32 mm	9.0	-	-40°C to +120°C	-	IP69K	-	481
13.0	496193	Coil with ISO-DIN connector, 12-24VDC for transportation applications, 32 mm	9.0	-	-40°C to +120°C	-	IP69K	-	481
14.1	483824	Coil with screw terminal, high temperature-high power, 40 mm	19.0	19.0	-40°C to +50°C	-	IP 44 to 67	-	477
14.2	483764	Coil for DIN plug connection, 32 mm, UL	-	9.0	-40°C to +50°C	●	IP65	-	451
14.3	483541	Coil with screw terminal, high temperature-high power, 40 mm	20.0	20.0	-40°C to +50°C	-	IP 44 to 67	-	478
20.0	ZB12	Coil for DIN plug connection	12.0	-	-10°C to +50°C	-	IP65	-	460
20.0	ZB09	Coil for DIN plug connection, UL for AC	-	9.0	-10°C to +50°C	●	IP65	-	460
20.1	YB12	Coil with flying leads, IP67	12.0	-	-10°C to +50°C	-	IP67	-	469
20.1	YB09	Coil with flying leads, IP67, UL for AC	-	9.0	-10°C to +50°C	●	IP67	-	469
20.2	ZB16	Coil for DIN plug connection, high power -high temperature series	16.0	-	-10°C to +50°C	-	IP65	-	461
20.2	ZH16	Coil for DIN plug connection, high power -high temperature series	16.0	-	-10°C to +80°C	-	IP65	-	461
20.2	ZB14	Coil for DIN plug connection, high power -high temperature series	-	14.0	-10°C to +50°C	-	IP65	-	461
20.2	ZH14	Coil for DIN plug connection, high power -high temperature series	-	14.0	-10°C to +80°C	-	IP65	-	461
21.0	JB14	Coil for DIN plug connection	16.0	-	-10°C to +50°C	-	IP65	-	462
21.0	JB16	Coil for DIN plug connection	-	14.0	-10°C to +50°C	-	IP65	-	462
22.0	KT10	Coil for DIN plug connection	10.0	-	-10°C to +50°C	-	IP65	-	463
22.0	KH09	Coil for DIN plug connection	-	9.0	-10°C to +80°C	-	IP65	-	463
22.0	KT09	Coil for DIN plug connection	-	9.0	-10°C to +50°C	-	IP65	-	463
23.0	XT09	Coil for DIN plug connection	-	9.0	-10°C to +50°C	-	IP54	-	464
24.0	D5	Coil for DIN plug connection, 32 mm	9.0	8.0	-40°C to +50°C	-	IP65	-	466
24.0	LA	Coil with flying leads, IP67, 32 mm	9.0	9.0	-10°C to +50°C	-	IP67	-	470
24.0	D4	Coil for DIN plug connection, 32 mm, UL	16.0	13.0	-40°C to +50°C	●	IP65	-	465
24.0	LB-LC	Coil with flying leads, IP 67, 32 mm, UL	16.0	13.0-14.0	-10°C to +50°C	●	IP67	-	471
24.0	XS03	Coil for DIN plug connection, 32 mm	-	9.0	-40°C to +50°C	-	IP65	-	467

## INDEX BY VALVE REFERENCE

Valve Order Number	Page	Valve Order Number	Page	Valve Order Number	Page	Valve Order Number	Page
360451J	186	363570	38	390525	180	392396	82
360452J	186	364010	182	390560	180	392408	82
360469	90	364035	182	390580	180	392409	82
360470	126	364520	134	390605	180	397146J	90
360475	126	364530	136	390625	180	398000	28
360479J	226	364535	136	390626	180	398001	28
360480J	226	364880J	126	390650	182	398003	28
360490J	226	364884J	126	390668	180	398006	30
360506	226	366501	54	390700	180	398007	30
361810	46	366511	54	390705	182	398008	30
361850	46	366521	54	390718	182	398010	30
361910	46	366531	54	390720	182	398012	30
361950	46	366601	68	390721	182	398013	28
362262	134	366606	68	390725	180	398014	28
362263	134	366611	68	390802	180	398016	28
362264	136	366616	68	390803	180	398017	28
362265	136	366770	54	390805	180	398018	28
362290	38	366775	54	390813	180	398022	28
362410J	220	390005	178	390874	180	398024	28
362460J	220	390034	178	390875	180	398026	28
362470J	220	390085	178	390878	180	398030	28
362475J	220	390086	178	390895	180	398034	28
362496J	126, 178	390088	178	390915	180	398052	28
362510J	180	390089	178	390945	180	398100	208
362518J	126, 180	390120	178	390975	180	398102	208
362524J	126, 180	390145	178	390995	180	398104	208
362530J	180	390150	178	390997	180	398112	208
362560J	208	390165	178	392169	82	398114	208
362570J	208	390195	178	392170	82	398120	208
362620J	208	390215	178	392173	82	398122	208
362630J	208	390216	178	392335	80	398130U	208
363282	38	390300	178	392349	80	398132	208
363378	28, 80	390405	178	392355	80	398134U	208
363380	28, 30	390445	178	392366	80	398136U	208
363390	30, 80	390457	178	392370	80	398138	208
363444	30, 82	390458	178	392372	80	398142	208
363457	30, 82	390465	178	392388	80	443776W	94
363467	30, 82	390495	178	392389	80	443777W	94
363475	38	390505	178	392395	82	443778W	94

## INDEX BY VALVE REFERENCE

<u>Valve Order Number</u>	<u>Page</u>	<u>Valve Order Number</u>	<u>Page</u>	<u>Valve Order Number</u>	<u>Page</u>
443779W	94	443796W	116	444494W	94
443780W	94	443797W	96	444497W	94
443781W	94	443798W	96	444499W	106
443782W	94	443799W	96	444500W	106
443783W	94	443800W	116	444501W	106
443784W	116	443801W	96	444502W	106
443785W	94	443802W	116	444503W	106
443786W	94	443803W	116	444513W	106
443787W	94	443804W	94	444576W	106
443788W	116	443805W	106	444600W	106
443789W	94	443806W	106	444601W	106
443790W	96	443807W	106	444602W	106
443791W	96	443808W	106	444603W	106
443792W	116	443809W	106	444604W	106
443793W	96	443810W	106	444605W	106
443794W	96	443811W	106		
443795W	96	444492W	94		

## INDEX FOR VALVES

Valve Reference	Page	Valve Reference	Page	Valve Reference	Page	Valve Reference	Page
U 033X0111	330	121K2423	184	122V8306	162	E 131K0358	210,302
U 033X5152	400	121K3106	36,86,144	PM 123AV	46	131K0397	210,214
U 033X5156	400	121K3206	36,86,144	PM 123CV	46	E 131K04	212,304
U 033X51561D	400	121K3303	128	PM 123DV	46	E 131K0450	212,304
U 033X5195	402	121K3306	36,86,144	PM 123IV	46	131K0490	210,302
U 033X5256	404	121K3321	184	PM 125BV	90	131K0497	212,304
U 033X52561D	404	E 121K45	36,86	PM 125CV.2	90	E 131K06	214,304
U 033X7156	402	E 121K4503	128	125K01	40,88	131K0648	272
PM 120.4AR	186	E 121K46	36,86	125K03	40	E 131K0650	214,304
PM 120.4IR	186	E 121K4603	128	PM 126YH	126	E 131K13	210
121F2523	188	121K6220	184	PM 126YT	126	E 131K14	210
E 121F43	42,146	E 121K63	34,142	PM 128GR	226	131K16	210
E 121F4302	42,92	E 121K64	34,144	PM 128IR	226	131K1650	210
121F4317	42	121K6423	184	PM 128ISV	226	E 131K63	216
E 121F44	42,146	E 121K65	32,142	PM 128IV	226	E 131K6350	216
E 121F4406	42,92	E 121K67	32,142	131.4BV	178	E 131K64	212
121F4417	42	121M13	32,84	131.4CG	180	E 131K6450	212
121F47	42	121M14	32,84	131.4FV	180	131M14	210,302
121F4706	42,146	121V5106	160	131.4GG	180	131M15	210,302
121F63	42,146	121V5112	160	131.4GV	180,182	131M74	228
121F64	42,146	121V5163	130,160	131AN	178	131M7450	228
121F67	42,146	121V5206	160	131B04	234	131M75	228
121G2320	184	121V5212	160	131B14	234	131M7550	228
121G2520	184	121V5263	130,160	E 131E03	216,306	131T21	216
121G2523	184	121V5306	158	E 131F26	238	131T2101	306
121K01	34,84	121V5363	130,158	E 131F43	230	131T22	216
121K0103	128	121V5397	160	E 131F4350	230	131T23	212
121K0106	34,84	121V5406	158	131F4397	312	131T2301	212
121K0113	128	121V5463	130,158	E 131F44	230	131T29	214
121K0150	34,84	121V5497	158	131F4410	228	131T2901	214
121K02	34,84	U 121V5595	170	E 131F4450	230	131V5306	252
121K0250	34,84	U 121V5596	170	131F4490	228	131V5363	252
E 121K03	34,142,144	U 121V55961D	170	131F4497	228	131V5397	252
E 121K0302	34,84	121V5706	158	131F46	230	131V5406	252
121K0323	128	121V5763	130,158	131F4650	230	131V5463	252
E 121K0352	34,84	122F44	44	U 131F5295	384	131V5490	252
121K0397	34	122K83	40	131F5406	236	131V5497	252
E 121K04	32,142	122K8306	40,86	U 131F5695	384	131X1101	334
E 121K0402	32,84	122K8321	188	U 131F56951D	384	U 131X1101	334
121K0497	32	121K8363	40,144	131IN	178	131X1131	334
E 121K07	32	122K84	40,144	131INDIN	178	U 131X1201	386
121K0706	32,84	122K8406	40	131IV	178	132F43	230
121K1302	32	122K8408	40,144	E 131K03	216	132F44	230
E 121K14	32,142	122K9321	188	E 131K0308	216,306	132F46	230
E 121K23	32,142	122K9363	40,144	E 131K0350	216,306	132K03	218

## INDEX FOR VALVES

Valve Reference	Page	Valve Reference	Page	Valve Reference	Page	Valve Reference	Page
132K04	218	U 133X5192	378	PM 156.2IR	134	221G1630	50
132K06	218	U 133X5195	384	PM 158IH	126	221G1631	50
132T22	218	U 133X51951D	386	PM 158IT	126	221G17	52
132T23	218	U 133X5196	378	161.4AV	80	221G1703	132
132T2301	218	U 133X51961D	380	161.4BV	80	221G1710	52
132T29	308	U 133X5296	382	161.4EV	82	221G1730	52
E 133F43	232	U 133X52961D	382	PM 168.1AN	54	221G1731	114
E 133F44	232	U 133X7156	380	PM 168.1CN	54	221G21	52
E 133F4450	232	U 133X7195	386	PM 168.1DN	54	221G2103	114
133F46	232	U 133X7196	380	PM 168.1IN	54	221G2106	52
133F4650	312	PM 135AT	134	PM 169.1AN	68	221G2110	52
E 133K03	222	PM 135CT	136	PM 169.1CN	68	221G2130	52
E 133K0350	222	PM 135DT	136	PM 169.1DN	68	221G2131	114
E 133K04	222	PM 135IT	134	PM 169.1IN	68	221G2136	52
E 133K0450	222	135K03	310	PM 173AN	54	221G23	48
133K0497	222	135K04	224	PM 173IN	54	221G2330	48
E 133K05	222	PM 136.2FV	38	2019F1GRG7	202	221G25	48
E 133K06	222	PM 136YV	38	2019F1GVG7	202	221G2523	190
E 133K0650	222	PM 139AV	220	2019F1JRG7	202	221G2530	48
E 133K13	222	PM 139FV	220	2019F1JVG7	202	221G26	50
E 133K14	222	PM 139GV	220	2019F1LRG7	202,204	221G2630	50
E 133K16	222	PM 139LV	220	2019F1LVG7	204	221G27	52
133T21	222	PM 140.AAR	180	2019F1NRG7	204	221G2730	52
133T2101	224	PM 140.4DR	180	2019F1NVG7	204	221J3301E	198
133T23	222	PM 140CR	126,180	201LG1GVG2	166	221S10E	172
133T2301	222	PM 140DR	126,180	201LG1JVG2	166	221S10F	172
133V5306	254	PM 140IR	126,178	201LG1LVG2	166	221S15E	172
133V5363	254	PM 141AV	208	201LG2GVG2	166	221S15F	172
133V5406	254	PM 141BV	208	201LG2JVG2	166	221S20E	172
133V5463	254	PM 141FV	208	201LG2LVG2	166	221S20F	172
U 133V5595	376	PM 141GV	208	201LG2NVG7	166	221S25E	174
U 133V55951D	376	PM 146.3ABV	30,82	201LG2PVG7	166	221S25F	174
U 133V5695	376	PM 146.3KV	30,82	201LG3SVG7	168	3019F1GRG7	258
U 133V56951D	376	PM 146BV	28,80	201LG3UVG7	168	3019F1GVG7	258
U 133V7595	376	PM 146FV	28,30,80	201LG4SVG7	168	3019F1JRG7	258,260
U 133V7695	376	PM 146HV	30,80	201LG4UVG7	168	3019F1JVG7	260
133X01	314	PM 146WV	30,82	221G13	48	3019F1LRG7	260
U 133X01	314	PM 146YV	30,82	221G1303	132	3019F1LVG7	260
133X01001D	314	PM 151GV	38	221G1330	132	3019F1NRG7	262
U 133X01111	308	PM 151HV	38	221G15	48	3019F1NVG7	262
U 133X011111D	308	PM 153BV	182	221G1503	132	301XGFRTG7	258
U 133X0131	310	PM 153GV	182	221G1530	48	301XGFRTJ7	260
U 133X5152	378	PM 156.2AR	134	221G16	50	301XGFRTL7	260
U 133X5156	378	PM 156.2CR	136	221G1603	132	301XGFRTN7	262
U 133X51561D	378	PM 156.2DR	136	221G1610	50	301XGFVTG7	258

## INDEX FOR VALVES

Valve Reference	Page	Valve Reference	Page	Valve Reference	Page	Valve Reference	Page
301XGFVTJ7	260	321K1536	268	322H35	70	341L0197	294
301XGFVTL7	260,262	321K1537	268	322H36	72	E 341L02	292
301XGFVTN7	262	321K1543	266	322H71	70	341L04	294
321F2523	194	E 321K25	60,100	322H7106	70,152	341L05	294
E 321F32	76,110	321K31	56,98	322H73	70,152	341L11	290
E 321F3202	76,154	321K3106	56	322H7306	70,152	E 341L1130	290
321F35	76	321K33	58,98	322H75	70,152	U 341L1130	290
E 321G36	62,102	321K3306	58	322H7506	70,152	E 341L21	286
E 321G3606	62	321K35	60,100	322K4106	108	341L2190	286
E 321G3610	118	321K3506	60	322K4306	108	341L9101	282
E 321G37	64,104	321K36	62,102	322K4506	108	341L9201	286
E 321G3706	64	321K3606	62	322K4606	108	341L9504	362
E 321G3710	120	321K37	64,104	322K4706	110	341L9534	362
321G3790	64	321K3706	64	325K4106	74	341L9594	364
E 321G38	64,104	321K4106	98,118	325K4306	74	341L9597	364
E 321G3806	64	321K4156	56	325K4506	74	341L9598	364
E 321G3810	120	321K4306	98,118	325K4606	74	341N01	340
E 321G39	66,104	321K4356	58	325K4706	74	341N02	346
E 321G3906	66	321K4506	100,118	E 331B01	240	U 341N0250	396
E 321G3910	120	321K4556	100,118	331B02	248	341N03	350
321G3990	66	321K4606	102,118	331B0216	248	341N04	350
E 321G40	66,104	321K4656	102,118	E 331B21	242	341N05	344
E 321G4006	66	321K4706	104,120	E 331B74	240	341N0502	346
E 321G4010	120	321K4756	104,120	331B7490	240	341N11	340
321G4090	66	E 321K63	148	E 331L21	244	341N12	348
E 321H11	56,148	322F35	76	331N03	336	341N21	340
E 321H13	58,148	322F72	76	331N04	336	341N2190	340
E 321H15	60,150	322F7206	76,154	331N0402	336	341N22	348
321H1590	60	322G36	72,108	331N34	338	341N31	342
E 321H21	148,192	322G3606	72	331N3402	338	341N3102	342
E 321H23	148,192	322G3610	122	E 332B01	242	341N3108	342
321H2322	192	322G37	72,110	332B02	242	341N3128	342
E 321H25	150,194	322G3706	72	E 332B21	244	341N3130	342
321H2522	194	322G3710	122	E 341B01	278	341N3190	342
321H2523	194	322G38	72	341B02	276	341N3196	342
321H35	60	322G3806	72	E 341B21	278	341N3197	342
321H36	62	322G3810	122	341B34	276	341N32	348
E 321K10	56,98	322G39	72,110	341B3403	276	341N3202	348
E 321K13	58,98	322G3906	72	341B3440	276	U 341N3250	394
E 321K1314	58,98	322G3910	122	341B3490	276	341N3290	344
E 321K15	60,100	322G40	72	E 341F21	278	U 341N3292	394
E 321K1503	138	322G4006	72	341F34	284	U 341N3295	394
E 321K1514	60,100	322G4010	122	341F3403	284	341N3296	344
321K1523	268	322G75	70,108	341F3440	284	341N3297	344
321K1535	266	322G7506	70,152	E 341L01	294	341N34	350

## INDEX FOR VALVES

Valve Reference	Page	Valve Reference	Page	Valve Reference	Page	Valve Reference	Page
341N35	346	E 347L1130	292	541N04	370	7321BMN02	116
341N3502	346	347L9101	282	542N03	372	7322BAH00	106
341P01	316	347L9201	288	547N03	370	7322BAN00	106
341P02	318	347N03	354	7321BAH00	94	7322BAV00	106
U 341P0250	388	347N04	356	7321BAN00	94	7322BCH00	106
341P03	318	347N11	352	7321BAN01	94	7322BCN00	106
341P04	322	347N12	354	7321BAV00	94	7322BCV00	106
341P21	316	347N31	352	7321BCH00	94	7322BDH00	106
341P2108	316	347N3190	352	7321BCN00	94	7322BDN00	106
341P2190	318	347N3197	352	7321BCN01	94	7322BDV00	106
341P2197	316	347N32	354	7321BCN02	116	7322BEH00	106
341P22	320	U 347N3250	398	7321BCV00	94	7322BEN00	106
341P2290	320	347N33	354	7321BDH00	94	7322BFH00	106
341P2297	320	347N34	356	7321BDN00	94	7322BFN00	106
U 341P3250	388	347P01	324	7321BDN01	94	7322BGH00	106
U 341P3292	390	347P02	326	7321BDN02	116	7322BGN00	106
341P3295	390	347P03	326	7321BDV00	94	7322BIH00	106
341P33	318	347P04	328	7321BEH00	96	7322BIN00	106
341P34	322	347P21	324	7321BEN00	96	7322BIV00	106
342N03	358	347P2190	324	7321BEN01	96	7322BLN06	106
342N11	358	347P2197	324	7321BEN02	116	7322BMN06	106
342N3197	358	347P22	326	7321BFH00	96	N74.4AV	28
342N33	358	U 347P3250	392	7321BFN00	96	N74.4AVA.5	28
343N03	360	U 347P3295	392	7321BFN01	96	N74.4FV	28
345B04	280	347P33	326	7321BFN02	116	N74.4IV	28
345B24	280	347P34	328	7321BGH00	96	N74.4WV	30
345B34	280	421F35	76	7321BGN00	96	N79.4AV	208
345F34	284	U 441P3250	388	7321BGN01	96	N79.4IV	208
345L01	296	531N03	366	7321BGN02	116	N79.6AV	208
345L21	288	531N04	366	7321BIH00	94	N79.6BV	208
345N31	362	541L01	298	7321BIN00	94		
345P21	328	541N01	368	7321BIN01	94		
347L04	288	541N0108	368	7321BIV00	94		
347L11	292	541N03	370	7321BLN02	116		

**WARNING - USER RESPONSIBILITY**

FAILURE OR IMPROPER SELECTION OR IMPROPER USE OF THE PRODUCTS DESCRIBED HEREIN OR RELATED ITEMS CAN CAUSE DEATH, PERSONAL INJURY AND PROPERTY DAMAGE.

- This document and other information from Parker-Hannifin Corporation, its subsidiaries and authorized distributors provide product or system options for further investigation by users having technical expertise.
- The user, through its own analysis and testing, is solely responsible for making the final selection of the system and components and assuring that all performance, endurance, maintenance, safety and warning requirements of the application are met. The user must analyze all aspects of the application, follow applicable industry standards, and follow the information concerning the product in the current product catalog and in any other materials provided from Parker or its subsidiaries or authorized distributors.
- To the extent that Parker or its subsidiaries or authorized distributors provide component or system options based upon data or specifications provided by the user, the user is responsible for determining that such data and specifications are suitable and sufficient for all applications and reasonably foreseeable uses of the components or systems.



# Parker's Motion & Control Technologies

At Parker, we're guided by a relentless drive to help our customers become more productive and achieve higher levels of profitability by engineering the best systems for their requirements. It means looking at customer applications from many angles to find new ways to create value.

Whatever the motion and control technology need, Parker has the experience, breadth of product and global reach to consistently deliver. No company knows more about motion and control technology than Parker.

For further info call  
00800 27 27 5374



## Aerospace

### Key Markets

Aftermarket services  
Commercial transports  
Engines  
General & business aviation  
Helicopters  
Launch vehicles  
Military aircraft  
Missiles  
Power generation  
Regional transports  
Unmanned aerial vehicles

### Key Products

Control systems & actuation products  
Engine systems & components  
Fluid conveyance systems & components  
Fluid metering, delivery & atomization devices  
Fuel systems & components  
Fuel tank inerting systems  
Hydraulic systems & components  
Thermal management  
Wheels & brakes



## Climate Control

### Key Markets

Agriculture  
Air conditioning  
Construction Machinery  
Food & beverage  
Industrial machinery  
Life sciences  
Oil & gas  
Precision cooling  
Process  
Refrigeration  
Transportation

### Key Products

Accumulators  
Advanced actuators  
CO<sub>2</sub> controls  
Electronic controllers  
Filter driers  
Hand shut-off valves  
Heat exchangers  
Hose & fittings  
Pressure regulating valves  
Refrigerant distributors  
Safety relief valves  
Smart pumps  
Solenoid valves  
Thermostatic expansion valves



## Hydraulics

### Key Markets

Aerial lift  
Agriculture  
Alternative energy  
Construction machinery  
Forestry  
Industrial machinery  
Machine tools  
Marine  
Material handling  
Mining  
Oil & gas  
Power generation  
Refuse vehicles  
Renewable energy  
Truck hydraulics  
Turf equipment

### Key Products

Accumulators  
Cartridge valves  
Electrohydraulic actuators  
Human machine interfaces  
Hybrid drives  
Hydraulic cylinders  
Hydraulic motors & pumps  
Hydraulic systems  
Hydraulic valves & controls  
Hydrostatic steering  
Integrated hydraulic circuits  
Power take-offs  
Power units  
Rotary actuators  
Sensors



## Pneumatics

### Key Markets

Aerospace  
Conveyor & material handling  
Factory automation  
Life science & medical  
Machine tools  
Packaging machinery  
Transportation & automotive

### Key Products

Air preparation  
Brass fittings & valves  
Manifolds  
Pneumatic accessories  
Pneumatic actuators & grippers  
Pneumatic valves & controls  
Quick disconnects  
Rotary actuators  
Rubber & thermoplastic hose & couplings  
Structural extrusions  
Thermoplastic tubing & fittings  
Vacuum generators, cups & sensors



## Electromechanical

### Key Markets

Aerospace  
Factory automation  
Life science & medical  
Machine tools  
Packaging machinery  
Paper machinery  
Plastics machinery & converting  
Primary metals  
Semiconductor & electronics  
Textile  
Wire & cable

### Key Products

AC/DC drives & systems  
Electric actuators, gantry robots & slides  
Electrohydraulic actuation systems  
Electromechanical actuation systems  
Human machine interface  
Linear motors  
Stepper motors, servo motors, drives & controls  
Structural extrusions



## Filtration

### Key Markets

Aerospace  
Food & beverage  
Industrial plant & equipment  
Life sciences  
Marine  
Mobile equipment  
Oil & gas  
Power generation & renewable energy  
Process  
Transportation  
Water Purification

### Key Products

Analytical gas generators  
Compressed air filters & dryers  
Engine air, coolant, fuel & oil filtration systems  
Fluid condition monitoring systems  
Hydraulic & lubrication filters  
Hydrogen, nitrogen & zero air generators  
Instrumentation filters  
Membrane & fiber filters  
Microfiltration  
Sterile air filtration  
Water desalination & purification filters & systems



## Fluid & Gas Handling

### Key Markets

Aerial lift  
Agriculture  
Construction machinery  
Food & beverage  
Fuel & gas delivery  
Industrial machinery  
Life sciences  
Marine  
Mining  
Mobile  
Oil & gas  
Renewable energy  
Transportation

### Key Products

Check valves  
Connectors for low pressure fluid conveyance  
Deep sea umbilicals  
Diagnostic equipment  
Hose couplings  
Industrial hose  
Mooring systems & power cables  
PTFE hose & tubing  
Quick couplings  
Rubber & thermoplastic hose  
Tube fittings & adapters  
Tubing & plastic fittings



## Process Control

### Key Markets

Alternative fuels  
Biopharmaceuticals  
Chemical & refining  
Food & beverage  
Marine & shipbuilding  
Medical & dental  
Microelectronics  
Nuclear Power  
Offshore oil exploration  
Oil & gas  
Pharmaceuticals  
Power generation  
Pulp & paper  
Steel  
Water/wastewater

### Key Products

Analytical Instruments  
Analytical sample conditioning products & systems  
Chemical injection fittings & valves  
Fluoropolymer chemical delivery fittings, valves & pumps  
High purity gas delivery fittings, valves, regulators & digital flow controllers  
Industrial mass flow meters/controllers  
Permanent no-weld tube fittings  
Precision industrial regulators & flow controllers  
Process control double block & bleeds  
Process control fittings, valves, regulators & manifold valves



## Sealing & Shielding

### Key Markets

Aerospace  
Chemical processing  
Consumer  
Fluid power  
General industrial  
Information technology  
Life sciences  
Microelectronics  
Military  
Oil & gas  
Power generation  
Renewable energy  
Telecommunications  
Transportation

### Key Products

Dynamic seals  
Elastomeric o-rings  
Electro-medical instrument design & assembly  
EMI shielding  
Extruded & precision-cut, fabricated elastomeric seals  
High temperature metal seals  
Homogeneous & inserted elastomeric shapes  
Medical device fabrication & assembly  
Metal & plastic retained composite seals  
Shielded optical windows  
Silicone tubing & extrusions  
Thermal management  
Vibration dampening

ENGINEERING YOUR SUCCESS.

## Parker Worldwide

### Europe, Middle East, Africa

**AE - United Arab Emirates, Dubai**  
Tel: +971 4 8127100  
parker.me@parker.com

**AT - Austria, Wiener Neustadt**  
Tel: +43 (0)2622 23501-0  
parker.austria@parker.com

**AT - Eastern Europe, Wiener Neustadt**  
Tel: +43 (0)2622 23501 900  
parker.easteurope@parker.com

**AZ - Azerbaijan, Baku**  
Tel: +994 50 2233 458  
parker.azerbaijan@parker.com

**BE/LU - Belgium, Nivelles**  
Tel: +32 (0)67 280 900  
parker.belgium@parker.com

**BY - Belarus, Minsk**  
Tel: +375 17 209 9399  
parker.belarus@parker.com

**CH - Switzerland, Etoy**  
Tel: +41 (0)21 821 87 00  
parker.switzerland@parker.com

**CZ - Czech Republic, Klecany**  
Tel: +420 284 083 111  
parker.czechrepublic@parker.com

**DE - Germany, Kaarst**  
Tel: +49 (0)2131 4016 0  
parker.germany@parker.com

**DK - Denmark, Ballerup**  
Tel: +45 43 56 04 00  
parker.denmark@parker.com

**ES - Spain, Madrid**  
Tel: +34 902 330 001  
parker.spain@parker.com

**FI - Finland, Vantaa**  
Tel: +358 (0)20 753 2500  
parker.finland@parker.com

**FR - France, Contamine s/Arve**  
Tel: +33 (0)4 50 25 80 25  
parker.france@parker.com

**GR - Greece, Athens**  
Tel: +30 210 933 6450  
parker.greece@parker.com

**HU - Hungary, Budapest**  
Tel: +36 23 885 470  
parker.hungary@parker.com

**IE - Ireland, Dublin**  
Tel: +353 (0)1 466 6370  
parker.ireland@parker.com

**IT - Italy, Corsico (MI)**  
Tel: +39 02 45 19 21  
parker.italy@parker.com

**KZ - Kazakhstan, Almaty**  
Tel: +7 7272 505 800  
parker.easteurope@parker.com

**NL - The Netherlands, Oldenzaal**  
Tel: +31 (0)541 585 000  
parker.nl@parker.com

**NO - Norway, Asker**  
Tel: +47 66 75 34 00  
parker.norway@parker.com

**PL - Poland, Warsaw**  
Tel: +48 (0)22 573 24 00  
parker.poland@parker.com

**PT - Portugal, Leca da Palmeira**  
Tel: +351 22 999 7360  
parker.portugal@parker.com

**RO - Romania, Bucharest**  
Tel: +40 21 252 1382  
parker.romania@parker.com

**RU - Russia, Moscow**  
Tel: +7 495 645-2156  
parker.russia@parker.com

**SE - Sweden, Spånga**  
Tel: +46 (0)8 59 79 50 00  
parker.sweden@parker.com

**SK - Slovakia, Banská Bystrica**  
Tel: +421 484 162 252  
parker.slovakia@parker.com

**SL - Slovenia, Novo Mesto**  
Tel: +386 7 337 6650  
parker.slovenia@parker.com

**TR - Turkey, Istanbul**  
Tel: +90 216 4997081  
parker.turkey@parker.com

**UA - Ukraine, Kiev**  
Tel: +380 44 494 2731  
parker.ukraine@parker.com

**UK - United Kingdom, Warwick**  
Tel: +44 (0)1926 317 878  
parker.uk@parker.com

**ZA - South Africa, Kempton Park**  
Tel: +27 (0)11 961 0700  
parker.southafrica@parker.com

### North America

**CA - Canada, Milton, Ontario**  
Tel: +1 905 693 3000

**US - USA, Cleveland**  
Tel: +1 216 896 3000

### Asia Pacific

**AU - Australia, Castle Hill**  
Tel: +61 (0)2-9634 7777

**CN - China, Shanghai**  
Tel: +86 21 2899 5000

**HK - Hong Kong**  
Tel: +852 2428 8008

**IN - India, Mumbai**  
Tel: +91 22 6513 7081-85

**JP - Japan, Tokyo**  
Tel: +81 (0)3 6408 3901

**KR - South Korea, Seoul**  
Tel: +82 2 559 0400

**MY - Malaysia, Shah Alam**  
Tel: +60 3 7849 0800

**NZ - New Zealand, Mt Wellington**  
Tel: +64 9 574 1744

**SG - Singapore**  
Tel: +65 6887 6300

**TH - Thailand, Bangkok**  
Tel: +662 186 7000-99

**TW - Taiwan, Taipei**  
Tel: +886 2 2298 8987

### South America

**AR - Argentina, Buenos Aires**  
Tel: +54 3327 44 4129

**BR - Brazil, Sao Jose dos Campos**  
Tel: +55 800 727 5374

**CL - Chile, Santiago**  
Tel: +56 2 623 1216

**MX - Mexico, Apodaca**  
Tel: +52 81 8156 6000

Ed. 2014-08-18



### EMEA Product Information Centre

Free phone: 00 800 27 27 5374

(from AT, BE, CH, CZ, DE, DK, EE, ES, FI, FR, IE, IL, IS, IT, LU, MT, NL, NO, PL, PT, RU, SE, SK, UK, ZA)

### US Product Information Centre

Toll-free number: 1-800-27 27 537

www.parker.com