

Pneumatic Valve Actuators - General information

Pressures to 150,000 psi (10342 bar)

Pneumatic Actuator

Pressures to 150,000 psi (10342 bar)

Six sizes of air operators (light, heavy light, medium, heavy duty or extra heavy, single and double stage) are offered for remote on-off operation or automatic operation of Parker Autoclave Engineer's low, medium or high pressure valves. The actuators are available in air-to-open (normally closed) and air-to-close (normally open) designs.

Remote on-off

Parker Autoclave Engineer's air-operated valves (**ATO**- Air-To-Open or **ATC**-Air-To-Close) can be controlled by a 3-way manual low pressure valve or by a low pressure solenoid valve. These are actuated by either a manual switch or an automatic control instrument. Parker Autoclave Engineer's air-operated, high pressure valves permit process control from a remotely located panel without the necessity of piping high pressure lines to the control panel. Safety is greatly increased and process "hold-up" is reduced. Prudent selection of ATO or ATC valves, together with the air controlling devices, permits the design of systems to "fail safe" in either the closed or open condition in the event of loss of operating air, or electrical failure, or malfunction.

Where explosion proof conditions are a requirement, pneumatic actuated valves can be considered. Remote mounting of the solenoid valve removes the potential from the hazardous area.

Ordering Procedure

To order a valve with an air operator, select the duty rating and type of the air operator from the chart below. Add the air operator identifying suffix to the catalog number of the Parker Autoclave Engineer's valve. To order a 2-way straight, 30VM vee stem, 9/16" valve with a medium duty air-to-close air operator, specify: ex: **30VM9071-C1S** for a yoke style piston air actuated valve or **30VM9071-CM** for an integral style diaphragm air operated valve.

To order the same valve with an extended high temperature stuffing box, add HT to the ordering number: ex: **30VM9071-C1SHT** or **30VM9071-CMHT**.

To order a dual air operator manifold valve, specify both operators if different. The same valve with a medium duty ATC on one stem and a medium duty ATO on the other, specify: ex: **30VM9075-C1S01S**.

To order a valve with operators for outdoor service add an "OD" suffix to the catalog number.

Note: Ordering air actuated valves models with regulating stems is not recommend. These are open/close actuators and will not regulate flow.

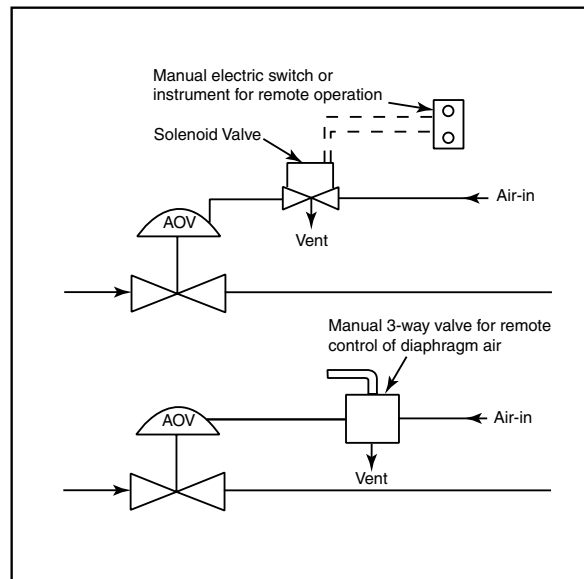

Duty Rating	Operator	Type	Ordering Suffix
Light	Diaphragm	Air-to-open	OL
		Air-to-close	CL
	Piston	Air-to-open	OLP
		Air-to-close	CLP
Mini-Light	Piston	Air-to-open	OHL P
		Air-to-close	CHL P
Medium	Diaphragm	Air-to-open	OM
		Air-to-close	CM
	Piston	Air-to-open	O1S
		Air-to-close	C1S
Heavy	Diaphragm	Air-to-open	OH
		Air-to-close	CH
	Piston	Air-to-open	O2S
		Air-to-close	C2S
Extra Heavy Single Stage	Piston	Air-to-open	H01S
		Air-to-close	HC1S
Extra Heavy Double Stage	Piston	Air-to-open	H02S
		Air-to-close	HC2S
Outdoor Service Actuators			
Medium	Piston	Air-to-open	O1SOD
		Air-to-close	C1SOD
Heavy	Piston	Air-to-open	O2SOD
		Air-to-close	C2SOD
Extra Heavy Single Stage	Piston	Air-to-open	H01SOD
		Air-to-close	HC1SOD
Extra Heavy Double Stage	Piston	Air-to-open	H02SOD
		Air-to-close	HC2SOD

Pneumatic Valve Actuators - Actuator Quick Selector Guide

This table allows the designer to quickly select an appropriate air actuator based on valve style and size, maximum system operating pressure and maximum available air pressure. For example, if the system operating pressure is 25,000 psi (1724 bar) and the

available air pressure is 60 psi (4.14 bar) and an air-to-open (spring fail closed) valve is required, a 30VM or 60VM valve with a heavy duty air operator can be used. More specific sizing data is available in the sizing charts on the following pages.

Valve Series	Tube Outside Diameter in (mm)	Air-to-Close									
		Light		Medium		Heavy		Extra Heavy Single Stage		Extra Heavy Two Stage	
		System Pressure psi (bar)	Air Pressure psi (bar)	System Pressure psi (bar)	Air Pressure psi (bar)	System Pressure psi (bar)	Air Pressure psi (bar)	System Pressure psi (bar)	Air Pressure psi (bar)	System Pressure psi (bar)	Air Pressure psi (bar)
10V	1/8 (3.18)	15,000 (1034.20)	100 (6.89)	15,000 (1034.20)	30 (2.07)						
	1/4 (6.35)	10,000 (689.46)	100 (6.89)	15,000 (1034.20)	40 (2.76)						
	3/8 (9.52)	10,000 (689.46)	100 (6.89)	15,000 (1034.20)	40 (2.76)						
	1/2 (12.70)			10,000 (689.46)	65 (4.48)						
SW	1/4 (6.35)			15,000 (1034.20)	65 (4.48)						
	3/8 (9.52)			15,000 (1034.20)	90 (6.21)	15,000 (1034.20)	50 (3.45)				
	1/2 (12.70)			8,000 (551.57)	100 (6.89)	10,000 (689.46)	60 (4.13)				
10SM	9/16 (14.27)			8,600 (592.94)	100 (6.89)	10,000 (689.45)	55 (3.79)	10,000 (689.45)	45 (3.10)	10,000 (689.46)	20 (1.38)
	3/4 (19.05)			4,800 (330.94)	100 (6.89)	10,000 (689.46)	100 (6.89)	10,000 (689.46)	75 (5.17)	10,000 (689.46)	35 (2.41)
	1 (25.40)			2,800 (193.05)	100 (6.89)	6,300 (434.36)	100 (6.89)	8,500 (586.04)	100 (6.89)	10,000 (689.46)	35 (2.41)
20SM	1/4 (6.35)			20,000 (1378.93)	95 (6.55)	20,000 (1378.93)	50 (3.45)				
	3/8 (9.52)			19,000 (1310.00)	100 (6.89)	20,000 (1378.93)	55 (3.79)				
	9/16 (14.27)			10,700 (737.73)	100 (6.89)	20,000 (1378.93)	85 (5.86)	20,000 (1378.93)	60 (4.13)	20,000 (1378.93)	30 (2.07)
	3/4 (19.05)			6,100 (420.57)	100 (6.89)	13,600 (937.67)	100 (6.89)	19,000 (1310.00)	100 (6.89)	20,000 (1378.93)	50 (3.45)
	1 (25.40)			3,900 (268.89)	100 (6.89)	8,800 (606.73)	100 (6.89)	12,500 (861.83)	100 (6.89)	20,000 (1378.93)	75 (5.17)

NOTE: For 10P and 15P series pipe valves see sizing data tables.

Maximum pressure rating is based on the lowest rating of any component. Actual working pressure may be determined by tubing pressure rating, if lower.

All dimensions for reference only and subject to change.

For prompt service, Parker Autoclave Engineers stocks select products. Consult your local representative.

Pneumatic Valve Actuators - Actuator Quick Selector Guide

Valve Series	Tube Outside Diameter in (mm)	Air-to-Open									
		Light		Medium		Heavy		Extra Heavy Single Stage		Extra Heavy Two Stage	
		System Pressure psi (bar)	Air Pressure psi (bar)	System Pressure psi (bar)	Air Pressure psi (bar)	System Pressure psi (bar)	Air Pressure psi (bar)	System Pressure psi (bar)	Air Pressure psi (bar)	System Pressure psi (bar)	Air Pressure psi (bar)
10V	1/8 (3.18)	8,200 (565.36)	60 (4.14)	15,000 (1034.20)	45 (3.10)						
	1/4 (6.35)	5,600 (386.10)	60 (4.14)	15,000 (1034.20)	65 (4.48)						
	3/8 (9.52)	5,600 (386.10)	60 (4.14)	15,000 (1034.20)	65 (4.48)						
	1/2 (12.70)			10,000 (689.46)	95 (6.55)						
SW	1/4 (6.35)			15,000 (1034.20)	100 (6.89)						
	3/8 (9.52)			10,000 (689.46)	95 (6.55)	15,000 (1034.20)	75 (5.17)				
	1/2 (12.70)			6,000 (413.68)	95 (6.55)	10,000 (689.46)	75 (5.17)				
10SM	9/16 (14.27)			7,900 (544.68)	95 (6.55)	10,000 (689.45)	75 (5.17)	10,000 (689.45)	65 (4.48)	10,000 (689.46)	40 (2.76)
	3/4 (19.05)							10,000 (689.46)	95 (6.55)	10,000 (689.46)	65 (4.14)
	1 (25.40)							6,500 (448.15)	100 (6.89)	10,000 (689.46)	85 (5.81)
20SM	1/4 (6.35)			20,000 (1378.93)	95 (6.55)	20,000 (1378.93)	50 (3.45)				
	3/8 (9.52)			18,250 (1258.27)	95 (6.55)	18,250 (1258.27)	50 (3.45)				
	9/16 (14.27)			9,800 (675.68)	95 (6.55)	15,700 (1082.46)	75 (5.17)	20,000 (1378.93)	85 (5.86)	20,000 (1378.93)	55 (3.79)
	3/4 (19.05)					6,000 (413.68)	75 (5.17)	15,000 (1034.20)	100 (6.89)	20,000 (1378.93)	80 (5.52)
	1 (25.40)					4,000 (275.79)	75 (5.17)	10,000 (689.46)	100 (6.89)	20,000 (1378.93)	100 (6.89)

NOTE: For 10P and 15P series pipe valves see sizing data tables.

Maximum pressure rating is based on the lowest rating of any component.
Actual working pressure may be determined by tubing pressure rating, if lower.

All dimensions for reference only and subject to change.

For prompt service, Parker Autoclave Engineers stocks select products. Consult your local representative.

Pneumatic Valve Actuators - Actuator Quick Selector Guide

Valve Series	Tube Outside Diameter in (mm)	Air-to-Close								Air-to-Open							
		Light		Medium		Heavy		Extra Heavy Two Stage		Light		Medium		Heavy		Extra Heavy Two Stage	
		System Pressure psi (bar)	Air Pressure psi (bar)	System Pressure psi (bar)	Air Pressure psi (bar)	System Pressure psi (bar)	Air Pressure psi (bar)	System Pressure psi (bar)	Air Pressure psi (bar)	System Pressure psi (bar)	Air Pressure psi (bar)	System Pressure psi (bar)	Air Pressure psi (bar)	System Pressure psi (bar)	Air Pressure psi (bar)	System Pressure psi (bar)	Air Pressure psi (bar)
30SC	1 (25.40)							30,000 (2068.39)	80 (5.52)							30,000 (2068.39)	80 (5.52)
30VM	1/4 (6.35)			30,000 (2068.39)	50 (3.45)	30,000 (2068.39)	30 (2.07)					30,000 (2068.39)	75 (5.17)	30,000 (2068.39)	40 (2.76)		
	3/8 (9.52)			30,000 (2068.39)	75 (5.17)	30,000 (2068.39)	40 (2.76)					30,000 (2068.39)	95 (6.55)	30,000 (2068.39)	50 (3.45)		
	9/16 (14.27)			30,000 (2068.39)	75 (5.17)	30,000 (2068.39)	40 (2.76)					30,000 (2068.39)	95 (6.55)	30,000 (2068.39)	50 (3.45)		
40VM	9/16 (14.27)					40,000 (2757.86)	45 (3.10)							40,000 (2757.86)	55 (3.79)		
60VM	1/4 (6.35)			60,000 (4136.79)	75 (5.17)	60,000 (4136.79)	40 (2.76)					60,000 (4136.79)	95 (6.55)	60,000 (4136.79)	50 (3.45)		
	3/8 (9.52)			60,000 (4136.79)	75 (5.17)	60,000 (4136.79)	40 (2.76)					60,000 (4136.79)	95 (6.55)	60,000 (4136.79)	50 (3.45)		
	9/16 (14.27)			60,000 (4136.79)	90 (6.21)	60,000 (4136.79)	45 (3.10)					60,000 (4136.79)	95 (6.55)	60,000 (4136.79)	50 (3.45)		
100VM	5/16 (7.92)			100,000 (6894.55)	100 (6.89)	100,000 (6894.65)	50 (3.45)							100,000 (6894.65)	70 (4.83)		
150V	5/16 (7.92)					150,000 (10341.97)	80 (5.52)							150,000 (10341.97)	75 (5.17)		

MVE/MV Mini Valves Series

Valve Series	Tube Outside Diameter in (mm)	Air-to-Close				Air-to-Open			
		Mini-Light				Mini-Light			
MVE	1/16 (1.57)	15,000 (1034.20)	75 (5.17)			15,000 (1034.20)	100 (6.89)		
MV	1/8 (3.18)	15,000 (1034.20)	75 (5.17)			15,000 (1034.20)	100 (6.89)		

Maximum pressure rating is based on the lowest rating of any component.
Actual working pressure may be determined by tubing pressure rating, if lower.

All dimensions for reference only and subject to change.

For prompt service, Parker Autoclave Engineers stocks select products. Consult your local representative.

Pneumatic Valve Actuators - Piston Style Pneumatic

Pressures to 150,000 psi (10342 bar)

Piston type air-operated valves offer a unique, reliable design providing for a long and dependable life. These valves are more compact than diaphragm valves and are appropriate for applications such as high-flow gas and liquid delivery systems to reactors and mixer/vaporizers.

Parker Autoclave Engineer's piston type actuators feature:

- Small, compact, piston actuator
- Air-to-open or -close with spring return
- Yoke design for separation of process and air pressure †
- Ease of stem replacement
- Stem position indicator is standard†
- Positive shut-off metal-to-metal seating
- High actuator cycle life
- 1/8" NPT air inlet connection except Extra Heavy duty has 3/8" NPT

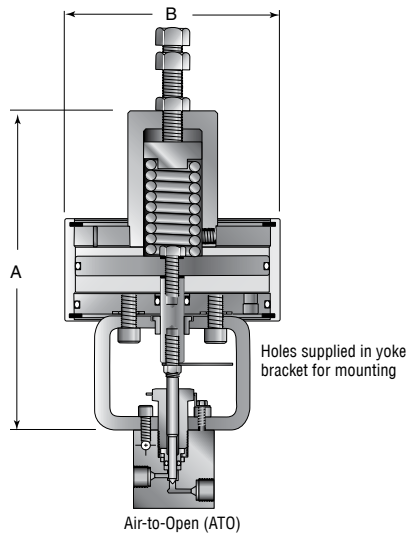

NOTE: Air inlet for air to open operator is located in the back, opposite the front of valve. For other locations, consult factory.

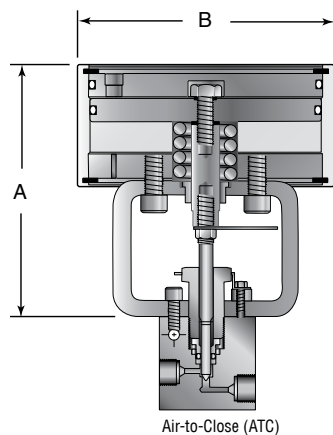

† The standard Mini-Light operator does not utilize the yoke design. A yoke design is available upon request.



Air Operator Materials

Cylinder, piston, cover plates, spring housing

- Anodized aluminum (for corrosion and wear resistance).

Yoke

- Painted Steel

Technical Data

Air Operator

- Maximum allowable working pressure: 100 psi (6.89 bar)
- Allowable piston temperature range: -20°F to 200°F (-29°C to 93°C)
- Area of piston:
 - Light duty - 4.9 sq. in (31.6 sq. cm)
 - Mini-Light duty - 5.4 sq. in (34.8 sq. cm)
 - Medium duty - 19.6 sq. in (126.5 sq. cm)
 - Heavy duty - 39.2 sq. in (252.9 sq. cm)
 - Extra Heavy duty single stage - 56 sq. in (361.3 sq. cm)
 - Extra Heavy duty double stage - 112 sq. in (722.6 sq. cm)
- Approximate air usage/cycle @ 100 psi (6.89 bar):
 - Light duty - .003 SCF (.00008 SCM)
 - Mini-Light duty - .007 SCF (.0002 SCM)
 - Medium duty - .04 SCF (.0011 SCM)
 - Heavy duty - .08 SCF (.0022 SCM)
 - Extra Heavy duty single stage - .33 SCF (.0095 SCM)
 - Extra Heavy duty double stage - .67 SCF (.019 SCM)
- Tested to 100,000 cycles at 100 psi (6.89 bar) with no leakage or signs of wear or fatigue.

Duty Rating	Type	Ordering Suffix	Dimensions: inches (mm)	
			A	B
Light	Air-to-open	OLP	5.50 (139.70)	2.81 (71.37)
	Air-to-close	CLP	3.94 (100.08)	2.81 (71.37)
† Mini-Light	Air-to-open	OHLP	3.84 (97.67)	3.06 (77.72)
	Air-to-close	CHLP	2.61 (66.3)	3.06 (77.70)
Medium	Air-to-open	O1S	8.25 (209.55)	5.69 (144.52)
	Air-to-close	C1S	5.50 (139.70)	5.69 (144.52)
Heavy	Air-to-open	O2S	11.88 (301.75)	5.69 (144.52)
	Air-to-close	C2S	8.50 (215.90)	5.69 (144.52)
Extra Heavy Single Stage	Air-to-open	HO1S	15.16 (385.06)	9.44 (239.77)
	Air-to-close	HC1S	8.75 (217.67)	9.44 (239.77)
Extra Heavy Two Stage	Air-to-open	HO2S	18.50 (469.90)	9.44 (239.78)
	Air-to-close	HC2S	11.94 (303.27)	9.44 (239.78)

Pneumatic Valve Actuators - Diaphragm Style Pneumatic

Pressures to 150,000 psi (10342 bar)

Diaphragm type air-operated valves are an efficient and economical means for "remote on-off" control of a wide range of process requirements. Diaphragm type actuators are designed to provide a dependable alternative to piston type actuators.

Parker Autoclave Engineer's diaphragm type air actuators feature:

- Economical diaphragm design
- Air-to-open or -close with spring return
- Integral connection of valve and operator for height restricted applications.
- Oversized weep holes for separation of process and air operator pressures.
- Stem position indicator optional
- Medium actuator cycle life
- 1/8" NPT air inlet connection



Air Operator Materials

Upper and lower housing, spring housing

- Anodized aluminum†

Diaphragm plate

- Cast ductile iron.

Technical Data

Air Operator

- Maximum allowable working pressure: 100 psi (6.89 bar)
- Allowable diaphragm temperature range: -40°F to 200°F (-40°C to 93°C)
- Area of diaphragm:
 - Light duty - 4.9 sq. in (31.6 sq. cm)
 - Medium duty - 19.6 sq. in (126.5 sq. cm)
 - Heavy duty - 45.66 sq. in (294.58 sq. cm)
- Approximate air usage/cycle @ 100 psi (6.89 bar):
 - Light duty - .007 SCF (.00019 SCM)
 - Medium duty - .07 SCF (.0019 SCM)
 - Heavy duty - .2 SCF (.0056 SCM)

†Note: OH and CH are carbon steel painted

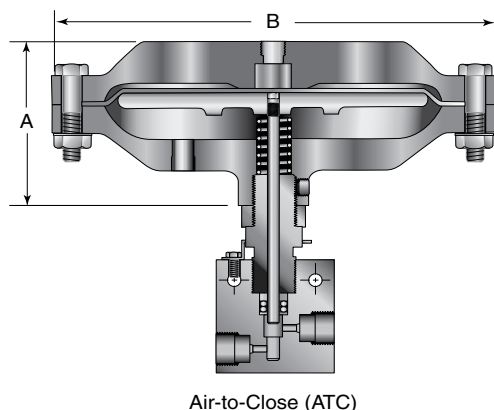
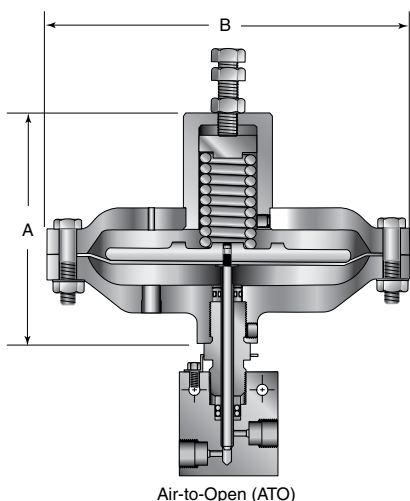

Duty Rating	Type	Ordering Suffix	Dimensions: inches (mm)	
			A	B
Light	Air-to-open	OL	5.00 (127.00)	4.25 (107.95)
	Air-to-close	CL	2.38 (60.45)	4.25 (107.95)
Medium	Air-to-open	OM	6.42 (163.01)	7.12 (180.90)
	Air-to-close	CM	3.75 (95.25)	7.12 (180.90)
Heavy	Air-to-open	OH	8.75 (222.25)	10.00 (254.00)
	Air-to-close	CH	4.69 (119.13)	10.00 (254.00)

Pneumatic Valve Actuators - Air Operator Sizing Data

Air-to-Close

Series 10V and SW Valves

Valve Series	Operator Duty	System Pressure KSI (Mpa)										Maximum Pressure psi (bar)*	Stem Travel in (mm)	Flow Coefficient**	
		1-4 (6.89-27.57)	6 (41.37)	8 (55.16)	10 (68.95)	12 (82.74)	14 (96.53)	15 (103.42)							
10V2	Light Duty	30 (2.07)	40 (2.76)	55 (3.79)	65 (4.48)	85 (5.86)	95 (6.55)	100 (6.89)					15,000 (1034.20)	0.16 (4.06)	0.12
	Medium Duty	25 (1.72)	25 (1.72)	25 (1.72)	25 (1.72)	25 (1.72)	25 (1.72)	30 (2.07)							
10V4	Light Duty	40 (2.76)	60 (4.13)	75 (5.17)	95 (6.55)								10,000 (689.46)	0.19 (4.83)	0.20
	Medium Duty	30 (2.07)	30 (2.07)	30 (2.07)	30 (2.07)	35 (2.41)	35 (2.41)	40 (2.76)					15,000 (1034.20)		
10V6	Light Duty	40 (2.76)	60 (4.13)	75 (5.17)	100 (6.89)								10,000 (689.46)	0.19 (4.83)	0.20
	Medium Duty	30 (2.07)	30 (2.07)	30 (2.07)	35 (2.41)	35 (2.41)	35 (2.41)	40 (2.76)					15,000 (1034.20)		
10V8	Medium Duty	50 (3.45)	50 (3.45)	55 (3.79)	65 (4.48)								10,000 (689.46)	0.31 (7.90)	0.86
SW4	Medium Duty	40 (2.76)	40 (2.76)	40 (2.76)	50 (3.45)	55 (3.79)	60 (4.13)	65 (4.48)					15,000 (1034.20)	0.25 (6.40)	0.65
SW6	Medium Duty	50 (3.45)	50 (3.45)	55 (3.79)	70 (4.83)	75 (5.17)	85 (5.86)	90 (6.21)					15,000 (1034.20)	0.25 (6.40)	0.95
	Heavy Duty	20 (1.38)	25 (1.72)	30 (2.07)	35 (2.41)	40 (2.76)	45 (3.10)	50 (3.45)					15,000 (1034.20)		
SW8	Medium Duty	65 (4.48)	70 (4.83)	100 (6.89)									8,000 (551.57)	0.38 (9.70)	1.90
	Heavy Duty	35 (2.41)	35 (2.41)	50 (3.45)	60 (4.13)								10,000 (689.46)		

Series 10SM Valves

Valve Series	Operator Duty	System Pressure KSI (Mpa)										Maximum Pressure psi (bar)*	Stem Travel in (mm)	Flow Coefficient**	
		1-3 (6.89-20.68)	4 (27.58)	6 (41.37)	8 (55.16)	10 (68.95)	12 (82.74)	14 (96.53)	16 (110.31)	18 (124.10)	20 (137.89)				
10SM9	Medium Duty	65 (4.48)	65 (4.48)	75 (5.17)	100 (6.89)								8,600 (592.94)	0.38 (9.65)	1.75
	Heavy Duty	35 (2.41)	35 (2.41)	40 (2.76)	50 (3.45)	55 (3.79)							10,000 (689.46)		
	Extra Heavy Duty Single Stage	30 (2.07)	30 (2.07)	30 (2.07)	35 (2.41)	45 (3.10)							10,000 (689.46)		
	Extra Heavy Duty Two Stage	15 (1.03)	15 (1.03)	15 (1.03)	20 (1.38)	20 (1.38)							10,000 (689.46)		
10SM12	Medium Duty	90 (6.21)	100 (6.89)										4,800 (330.94)	0.44 (11.18)	2.80
	Heavy Duty	45 (3.10)	45 (3.10)	60 (4.13)	80 (5.52)	100 (6.89)							10,000 (689.46)		
	Extra Heavy Duty Single Stage	35 (2.41)	35 (2.41)	50 (3.45)	60 (4.13)	70 (4.83)							10,000 (689.46)		
	Extra Heavy Duty Two Stage	20 (1.38)	20 (1.38)	25 (1.72)	30 (2.07)	35 (2.41)							10,000 (689.46)		
10SM16	Medium Duty	100 (6.89)											2,800 (193.05)	0.56 (14.22)	5.20
	Heavy Duty	60 (4.13)	70 (4.83)	100 (6.89)									6,300 (434.36)		
	Extra Heavy Duty Single Stage	45 (3.10)	50 (3.45)	70 (4.83)	95 (6.55)								8,500 (586.46)		
	Extra Heavy Duty Two Stage	25 (1.72)	25 (1.72)	35 (2.41)	45 (3.10)	55 (3.79)							10,000 (689.46)		

Air-to-Close - Series 20SM Valves

Valve Series	Operator Duty		System Pressure KSI (Mpa)										Maximum Pressure psi (bar)*	Stem Travel in (mm)	Flow Coefficient**
			1-3 (6.89-20.68)	4 (27.58)	6 (41.37)	8 (55.16)	10 (68.95)	12 (82.74)	14 (96.53)	16 (110.31)	18 (124.10)	20 (137.89)			
20SM4 15P4†	Medium Duty	Air Pressure psi (bar)	40 (2.76)	40 (2.76)	40 (2.76)	40 (2.76)	50 (3.45)	60 (4.13)	70 (4.83)	80 (5.52)	85 (5.86)	95 (6.55)	20,000 (1378.93)	0.25 (6.35)	0.31
	Heavy Duty		20 (1.38)	20 (1.38)	20 (1.38)	20 (1.38)	25 (1.72)	30 (2.07)	35 (2.41)	40 (2.76)	45 (3.10)	50 (3.45)			
20SM6 15P6†	Medium Duty		45 (3.10)	45 (3.10)	45 (3.10)	45 (3.10)	55 (3.79)	65 (4.48)	75 (5.17)	85 (5.86)	95 (6.55)	100 (6.89)	19,000 (1309.98)	0.25 (6.35)	0.75
	Heavy Duty		25 (1.72)	25 (1.72)	25 (1.72)	25 (1.72)	30 (2.07)	35 (2.41)	40 (2.76)	45 (3.10)	50 (3.45)	55 (3.79)			
20SM9 15P9†	Medium Duty		60 (4.13)	60 (4.13)	65 (4.48)	80 (5.52)	100 (6.89)						10,700 (737.73)	0.38 (9.65)	1.30
	Heavy Duty		30 (2.07)	30 (2.07)	30 (2.07)	40 (2.76)	50 (3.45)	55 (3.79)	60 (4.13)	70 (4.83)	80 (5.52)	85 (5.86)			
	Extra Heavy Duty Single Stage		25 (1.72)	25 (1.72)	25 (1.72)	30 (2.07)	35 (2.41)	45 (3.10)	50 (3.45)	55 (3.79)	60 (4.13)	65 (4.48)			
	Extra Heavy Duty Two Stage		15 (1.03)	15 (1.03)	15 (1.03)	15 (1.03)	20 (1.38)	20 (1.38)	25 (1.72)	25 (1.72)	30 (2.07)	30 (2.07)			
20SM12 10P12†	Medium Duty		80 (5.44)	80 (5.44)	100 (6.80)								6,100 (420.57)	0.44 (11.18)	2.50
	Heavy Duty		40 (2.72)	40 (2.72)	50 (3.40)	60 (4.08)	75 (5.10)	90 (6.12)	100 (6.80)						
	Extra Heavy Duty Single Stage	30 (2.07)	30 (2.07)	40 (2.76)	50 (3.45)	60 (4.13)	65 (4.48)	75 (5.17)	85 (5.86)	95 (6.55)	100 (6.89)				
	Extra Heavy Duty Two Stage	15 (1.03)	15 (1.03)	20 (1.38)	25 (1.72)	30 (2.07)	35 (2.41)	40 (2.76)	45 (3.10)	50 (3.45)	50 (3.45)				
20SM16 10P16†	Medium Duty	100 (6.89)	100 (6.89)									3,900 (268.89)	0.56 (14.22)	3.40	
	Heavy Duty	50 (3.45)	50 (3.45)	70 (4.83)	100 (6.89)										
	Extra Heavy Duty Single Stage	40 (2.76)	40 (2.76)	55 (3.79)	70 (4.83)	85 (5.86)	100 (6.89)								
	Extra Heavy Duty Two Stage	20 (1.38)	20 (1.38)	25 (1.72)	35 (2.41)	40 (2.76)	50 (3.45)	55 (3.79)	60 (4.48)	70 (4.83)	75 (5.17)				

Series 30SC Valves

Valve Series	Operator Duty		System Pressure KSI (Mpa)										Maximum Pressure psi (bar)*	Stem Travel in (mm)	Flow Coefficient**
			1-10 (6.89-68.94)	15 (103.42)	16 (110.31)	18 (124.10)	20 (137.89)	22 (151.68)	24 (165.47)	26 (179.26)	28 (193.05)	30 (206.84)			
30SC16	Extra Heavy Duty Two Stage	Air Pressure psi (bar)	30 (2.07)	40 (2.76)	45 (3.10)	50 (3.45)	55 (3.79)	60 (4.13)	65 (4.48)	70 (4.83)	75 (5.17)	80 (5.52)	30,000 (2068.39)	0.50 (12.70)	2.61

** C_v data is for 2-way straight valves.
For angle pattern, add approximately 50% to the C_v valve.

CAUTION: While testing has shown O-rings to provide satisfactory service life, both cyclic and shelf life may vary widely with differing service conditions, properties of reactants, pressure and temperature cycling and age of the O-ring. FREQUENT INSPECTIONS SHOULD BE MADE to detect any deterioration, and O-rings replaced as required.

*Maximum pressure rating is based on the lowest rating of any component.
Actual working pressure may be determined by tubing pressure rating, if lower.

All dimensions for reference only and subject to change.

For prompt service, Parker Autoclave Engineers stocks select products. Consult your local representative.

Air-to-Close - Series 30VM Valves

Valve Series	Operator Duty		System Pressure KSI (Mpa)										Maximum Pressure psi (bar)*	Stem Travel in (mm)	Flow Coefficient**	
			1-10 (6.89-68.94)	12 (82.74)	14 (96.53)	16 (110.31)	18 (124.10)	20 (137.89)	22 (151.68)	24 (165.47)	26 (179.26)	28 (193.05)				30 (206.84)
30VM4	Medium Duty	Air Pressure psi (bar)	25 (1.72)	25 (1.72)	25 (1.72)	30 (2.07)	35 (2.41)	35 (2.41)	40 (2.76)	45 (3.10)	50 (3.45)	55 (3.79)	30,000 (2068.39)	0.19 (4.83)	0.12	
	Heavy Duty		15 (1.03)	15 (1.03)	15 (1.03)	15 (1.03)	20 (1.38)	20 (1.38)	20 (1.38)	25 (1.72)	25 (1.72)	30 (2.07)				
30VM6 & 30VM9	Medium Duty		30 (2.07)	30 (2.07)	35 (2.41)	40 (2.76)	45 (3.10)	50 (3.45)	55 (3.79)	60 (4.13)	65 (4.48)	70 (4.83)	75 (5.17)	30,000 (2068.39)	0.19 (4.83)	0.23 (30VM6)
	Heavy Duty		15 (1.03)	15 (1.03)	20 (1.38)	20 (1.38)	25 (1.72)	25 (1.72)	30 (2.07)	30 (2.07)	35 (2.41)	35 (2.41)	40 (2.76)			0.33 (30VM9)

Series 40VM Valves

Valve Series	Operator Duty		System Pressure KSI (Mpa)							Maximum Pressure psi (bar)*	Stem Travel in (mm)	Flow Coefficient**
			1-10 (6.89-68.94)	15 (103.42)	20 (137.89)	25 (172.37)	30 (206.84)	35 (241.31)	40 (275.79)			
40VM9	Medium Duty	Air Pressure psi (bar)	40 (2.76)	50 (3.45)	60 (4.13)	70 (4.83)	80 (5.52)	90 (6.21)	90 (6.21)	40,000 (2757.86)	0.25 (6.35)	0.28
	Heavy Duty		20 (1.38)	25 (1.70)	30 (2.07)	35 (2.41)	40 (2.76)	45 (3.10)	45 (3.10)			

Series 60VM Valves

Valve Series	Operator Duty		System Pressure KSI (Mpa)										Maximum Pressure psi (bar)*	Stem Travel in (mm)	Flow Coefficient**
			1-20 (6.89-137.89)	25 (172.37)	30 (206.84)	35 (241.31)	40 (275.79)	45 (310.26)	50 (344.73)	55 (379.21)	60 (413.68)				
60VM4 & 60VM6	Medium Duty	Air Pressure psi (bar)	30 (2.07)	30 (2.07)	35 (2.41)	45 (3.10)	50 (3.45)	55 (3.79)	60 (4.13)	70 (4.83)	75 (5.17)	60,000 (4136.79)	0.25 (6.35)	0.08 (60VM4)	
	Heavy Duty		15 (1.03)	15 (1.03)	20 (1.38)	25 (1.72)	25 (1.72)	30 (2.07)	30 (2.07)	35 (2.41)	40 (2.76)			0.09 (60VM6)	
60VM9	Medium Duty		35 (2.41)	40 (2.76)	50 (3.45)	55 (3.79)	65 (4.48)	70 (4.83)	75 (5.17)	85 (5.86)	90 (6.21)	60,000 (4136.79)	0.25 (6.35)	0.14	
	Heavy Duty		20 (1.38)	20 (1.38)	25 (1.72)	30 (2.07)	35 (2.41)	35 (2.41)	40 (2.76)	45 (3.10)	45 (3.10)				

Series 100VM & 150V Valves

Valve Series	Operator Duty		System Pressure KSI (Mpa)										Maximum Pressure psi (bar)*	Stem Travel in (mm)	Flow Coefficient**
			1-40 (6.89-275.79)	50 (344.73)	60 (413.68)	70 (482.63)	80 (551.57)	90 (620.52)	100 (689.46)	150 (1034.20)					
100VM4 100VM5 100VM6	Medium Duty	Air Pressure psi (bar)	50 (3.45)	55 (3.79)	65 (4.48)	75 (5.17)	85 (5.86)	95 (6.55)	100 (6.89)			100,000 (6894.65)	0.12 (3.05)	0.09	
	Heavy Duty		30 (2.07)	30 (2.07)	35 (2.41)	40 (2.76)	40 (2.76)	45 (3.10)	50 (3.45)						
150V5	Heavy Duty		35 (2.41)	40 (2.76)	45 (3.10)	45 (3.10)	50 (3.45)	55 (3.79)	60 (4.13)	100 (6.89)			150,000 (10341.97)	0.12 (3.05)	0.06

Pneumatic Valve Actuators - Air Operator Sizing Data

Air-to-Open

Series 10V Valves

Valve Series	Operator Duty	System Pressure KSI (Mpa)										Maximum Pressure psi (bar)**	Flow Coefficient Cv***	
		1-6 (6.89-41.37)	8 (110.31)	10 (124.10)	12 (82.74)	14 (96.53)	15 (103.42)							
10V2	Light Duty	Air Pressure: psi (bar)	60 (4.13)	60 (4.13)									8,200 (565.36)	0.12 to 0.09****
		Spring Pre-Compression: in. (mm)	0.31 (7.87)	0.38 (9.65)										
		Stem Travel in (mm)	0.12 (3.05)	0.06 (1.52)										
	Medium Duty	Air Pressure: psi (bar)	40 (2.76)	40 (2.76)	40 (2.76)	40 (2.76)	40 (2.76)	45 (3.10)					15,000 (1034.20)	0.12
		Spring Pre-Compression: in. (mm)	0.12 (3.05)	0.12 (3.05)	0.12 (3.05)	0.12 (3.05)	0.12 (3.05)	0.16 (4.06)						
		Stem Travel in (mm)	0.12 (3.05)	0.12 (3.05)	0.12 (3.05)	0.12 (3.05)	0.12 (3.05)	0.12 (3.05)						
10V4 10V6	Light Duty	Air Pressure: psi (bar)	60 (4.13)									5,600 (386.46)	0.02 to 0.17****	
		Spring Pre-Compression: in. (mm)	0.38 (9.65)											
		Stem Travel in (mm)	0.06 (1.52)											
10V4	Medium Duty	Air Pressure: psi (bar)	45 (3.10)	45 (3.10)	50 (3.45)	55 (3.79)	60 (4.14)	65 (4.48)				15,000 (1034.20)	0.20	
		Spring Pre-Compression: in. (mm)	0.12 (3.05)	0.12 (3.05)	0.14 (3.65)	0.18 (4.75)	0.20 (5.08)	0.22 (5.59)						
		Stem Travel in (mm)	0.19 (4.83)	0.19 (4.83)	0.19 (4.83)	0.19 (4.83)	0.19 (4.83)	0.19 (4.83)						
10V6	Medium Duty	Air Pressure: psi (bar)	45 (3.10)	45 (3.10)	50 (3.45)	55 (3.79)	60 (4.13)	65 (4.48)				15,000 (1034.20)	0.20	
		Spring Pre-Compression: in. (mm)	0.12 (3.05)	0.12 (3.05)	0.14 (3.56)	0.18 (4.57)	0.20 (5.08)	0.22 (5.57)						
		Stem Travel in (mm)	0.19 (4.83)	0.19 (4.83)	0.19 (4.83)	0.19 (4.83)	0.19 (4.83)	0.19 (4.83)						
10V8	Medium Duty	Air Pressure: psi (bar)	75 (5.17)	85 (5.86)	95 (6.55)							10,000 (689.46)	0.86	
		Spring Pre-Compression: in. (mm)	0.25 (6.35)	0.30 (7.62)	0.38 (9.65)									
		Stem Travel in (mm)	0.25 (6.35)	0.25 (6.35)	0.25 (6.35)									
	Heavy Duty	Air Pressure: psi (bar)	50 (3.45)	55 (3.79)	60 (4.13)							10,000 (689.46)	0.86	
		Spring Pre-Compression: in. (mm)	0.14 (3.56)	0.20 (5.08)	0.24 (6.10)									
		Stem Travel in (mm)	0.25 (6.35)	0.25 (6.35)	0.25 (6.35)									

** C_v data is for 2-way straight valves.
For angle pattern, add approximately 50% to the C_v valve.

CAUTION: While testing has shown O-rings to provide satisfactory service life, both cyclic and shelf life may vary widely with differing service conditions, properties of reactants, pressure and temperature cycling and age of the O-ring. FREQUENT INSPECTIONS SHOULD BE MADE to detect any deterioration, and O-rings replaced as required.

*Maximum pressure rating is based on the lowest rating of any component.
Actual working pressure may be determined by tubing pressure rating, if lower.

All dimensions for reference only and subject to change.

For prompt service, Parker Autoclave Engineers stocks select products. Consult your local representative.

Air-to-Open

Series SW Valves

Valve Series	Operator Duty	System Pressure KSI (Mpa)										Maximum Pressure psi (bar)*	Flow Coefficient Cv**	
		1-6 (6.89-41.37)	8 (55.16)	10 (68.95)	12 (82.74)	14 (96.53)	15 (103.41)							
SW4	Medium Duty	Air Pressure: psi (bar)	65 (4.48)	65 (4.48)	75 (5.17)	85 (5.52)	95 (6.55)	95 (6.55)					15,000 (1034.20)	0.65
		Spring Pre-Compression: in. (mm)	0.19 (4.83)	0.19 (4.83)	0.25 (6.35)	0.31 (7.87)	0.36 (9.14)	0.38 (9.14)						
		Stem Travel in (mm)	0.25 (6.35)	0.25 (6.35)	0.25 (6.35)	0.25 (6.35)	0.25 (6.35)	0.25 (6.35)						
SW6	Medium Duty	Air Pressure: psi (bar)	75 (5.17)	75 (5.17)	95 (6.55)	95 (6.55)	95 (6.55)	100 (6.89)					13,500 (930.77)	0.62 to 0.95
		Spring Pre-Compression: in. (mm)	0.25 (6.35)	0.25 (6.35)	0.28 (7.11)	0.44 (11.17)	0.52 (13.21)	0.56 (14.22)						
		Stem Travel in (mm)	0.25 (6.35)	0.25 (6.35)	0.25 (6.35)	0.19 (4.83)	0.10 (2.54)	0.06 (1.53)						
SW6	Heavy Duty	Air Pressure: psi (bar)	50 (3.45)	55 (3.79)	60 (4.13)	65 (4.48)	70 (4.83)	75 (5.17)					15,000 (1034.20)	0.95
		Spring Pre-Compression: in. (mm)	0.14 (3.56)	0.19 (4.83)	0.24 (6.10)	0.28 (7.11)	0.34 (8.64)	0.36 (9.14)						
		Stem Travel in (mm)	0.25 (6.35)	0.25 (6.35)	0.25 (6.35)	0.25 (6.35)	0.25 (6.35)	0.25 (6.35)						
SW8	Medium Duty	Air Pressure: psi (bar)	95 (6.55)	95 (6.55)									7,200 (469.41)	1.75
		Spring Pre-Compression: in. (mm)	0.38 (9.65)	0.56 (14.22)										
		Stem Travel in (mm)	0.25 (6.35)	0.05 (1.53)										
SW8	Heavy Duty	Air Pressure: psi (bar)	65 (4.48)	75 (5.17)	75 (5.17)								10,000 (689.46)	1.14
		Spring Pre-Compression: in. (mm)	0.28 (7.11)	0.38 (9.65)	0.44 (11.18)									
		Stem Travel in (mm)	0.25 (6.35)	0.25 (6.35)	0.19 (4.83)									

Series MVE/MV Valves

Valve Series	Operator Duty	System Pressure KSI (Mpa)										Maximum Pressure psi (bar)*	Flow Coefficient Cv**	
		1-6 (6.89-41.37)	8 (55.15)	10 (68.95)	12 (82.74)	14 (96.53)	15 (103.41)							
MVE1 MV1	Mini-Light Duty	Air Pressure: psi (bar)	60 (4.13)	65 (4.48)	75 (5.17)	85 (5.86)	90 (6.21)	100 (6.89)					15,000 (1034.20)	MVE1/MV1 (0.05)
		Spring Pre-Compression: in. (mm)	0.073 (1.85)	0.094 (2.39)	0.125 (3.18)	0.147 (3.73)	0.172 (4.37)	0.188 (4.78)						
		Stem Travel in (mm)	0.094 (2.39)	0.094 (2.39)	0.094 (2.39)	0.094 (2.39)	0.094 (2.39)	0.094 (2.39)						
MVE2 MV2													MVE2/MV2 (0.11)	

** C_v data is for 2-way straight valves.
For angle pattern, add approximately 50% to the C_v value.

CAUTION: While testing has shown O-rings to provide satisfactory service life, both cyclic and shelf life may vary widely with differing service conditions, properties of reactants, pressure and temperature cycling and age of the O-ring, FREQUENT INSPECTIONS SHOULD BE MADE to detect any deterioration, and O-rings replaced as required.

*Maximum pressure rating is based on the lowest rating of any component.
Actual working pressure may be determined by tubing pressure rating, if lower.

All dimensions for reference only and subject to change.

For prompt service, Parker Autoclave Engineers stocks select products. Consult your local representative.

Air-to-Open - Series 10SM Valves

Valve Series	Operator Duty	System Pressure KSI (Mpa)										Maximum Pressure psi (bar)*	Flow Coefficient Cv**	
		1-4 (6.89-27.58)	6 (41.37)	8 (55.15)	10 (68.95)	12 (82.74)	14 (96.53)	16 (110.31)	18 (124.10)	20 (137.89)				
10SM9	Medium Duty	Air Pressure: psi (bar)	95 (6.55)	95 (6.55)	95 (6.55)								7,900 (544.68)	1.74 to 0.72***
		Spring Pre-Compression: in. (mm)	0.38 (9.65)	0.44 (11.18)	0.56 (14.22)									
		Stem Travel in (mm)	0.25 (6.35)	0.19 (4.83)	0.06 (1.52)									
	Heavy Duty	Air Pressure: psi (bar)	55 (3.79)	65 (4.48)	70 (4.83)	75 (5.17)							10,000 (689.46)	1.74 to 0.72***
		Spring Pre-Compression: in. (mm)	0.22 (5.59)	0.28 (7.11)	0.34 (8.64)	0.44 (11.18)								
		Stem Travel in (mm)	0.25 (6.35)	0.25 (6.35)	0.25 (6.35)	0.19 (4.83)								
	Extra Heavy Duty Single Stage	Air Pressure: psi (bar)	45 (3.10)	45 (3.10)	55 (3.79)	60 (4.13)							10,000 (689.46)	1.75
		Spring Pre-Compression: in. (mm)	0.31 (7.87)	0.34 (8.64)	0.47 (11.94)	0.59 (14.99)								
		Stem Travel in (mm)	0.38 (9.65)	0.38 (9.65)	0.38 (9.65)	0.38 (9.65)								
	Extra Heavy Duty Two Stage	Air Pressure: psi (bar)	25 (1.72)	30 (2.07)	35 (2.41)	40 (2.76)							10,000 (689.46)	1.75
		Spring Pre-Compression: in. (mm)	0.16 (4.06)	0.19 (4.83)	0.25 (6.35)	0.28 (7.11)								
		Stem Travel in (mm)	0.38 (9.65)	0.38 (9.65)	0.38 (9.65)	0.38 (9.65)								
10SM12	Extra Heavy Duty Single Stage	Air Pressure: psi (bar)	55 (3.79)	65 (4.48)	80 (5.52)	95 (6.55)							10,000 (689.46)	2.80
		Spring Pre-Compression: in. (mm)	0.44 (11.18)	0.63 (16.00)	0.84 (21.34)	1.06 (26.92)								
		Stem Travel in (mm)	0.44 (11.18)	0.44 (11.18)	0.44 (11.18)	0.44 (11.18)								
	Extra Heavy Duty Two Stage	Air Pressure: psi (bar)	40 (2.76)	50 (3.45)	55 (3.79)	60 (4.13)							10,000 (689.46)	2.80
		Spring Pre-Compression: in. (mm)	0.22 (5.59)	0.31 (7.87)	0.44 (11.18)	0.53 (13.46)								
		Stem Travel in (mm)	0.44 (11.18)	0.44 (11.18)	0.44 (11.18)	0.44 (11.18)								
10SM16	Extra Heavy Duty Single Stage	Air Pressure: psi (bar)	75 (5.17)	100 (6.89)									6,500 (448.15)	5.20
		Spring Pre-Compression: in. (mm)	0.69 (17.53)	1.13 (28.70)										
		Stem Travel in (mm)	0.50 (12.70)	0.50 (12.70)										
	Extra Heavy Duty Two Stage	Air Pressure: psi (bar)	55 (3.79)	65 (4.48)	75 (5.17)	85 (5.86)							10,000 (689.46)	5.20
		Spring Pre-Compression: in. (mm)	0.34 (8.64)	0.53 (13.46)	0.69 (17.53)	0.88 (22.35)								
		Stem Travel in (mm)	0.50 (12.70)	0.50 (12.70)	0.50 (12.70)	0.50 (12.70)								

Air-to-Open -Series 20SM Valves

Valve Series	Operator Duty		System Pressure KSI (Mpa)										Maximum Pressure psi (bar)*	Flow Coefficient Cv***	
			1-4 (6.89-27.58)	6 (41.37)	8 (55.15)	10 (68.95)	12 (82.74)	14 (96.53)	16 (110.31)	18 (124.10)	20 (137.89)				
20SM4 15P4†	Medium Duty	Air Pressure: psi (bar)	65 (4.48)	65 (4.48)	65 (4.48)	75 (5.17)	85 (5.86)	95 (6.55)	95 (6.55)	95 (6.55)	95 (6.55)			20,000 (1378.93)	0.31 to 0.22***
		Spring Pre-Compression: in. (mm)	0.19 (4.83)	0.19 (4.83)	0.19 (4.83)	0.25 (6.35)	0.31 (7.87)	0.38 (9.65)	0.44 (11.18)	0.50 (12.70)	0.56 (14.22)				
	Stem Travel in (mm)	0.25 (6.35)	0.25 (6.35)	0.25 (6.35)	0.25 (6.35)	0.25 (6.35)	0.25 (6.35)	0.19 (4.83)	0.12 (3.05)	0.06 (1.52)					
	Heavy Duty	Air Pressure: psi (bar)	35 (2.41)	35 (2.41)	35 (2.41)	40 (2.76)	45 (3.10)	50 (3.45)	50 (3.45)	50 (3.45)	50 (3.45)				
20SM6 15P6†	Medium Duty	Air Pressure: psi (bar)	65 (4.48)	65 (4.48)	75 (5.17)	85 (5.86)	95 (6.55)	95 (6.55)	95 (6.55)					18,250 (1258.27)	0.75 to 0.57***
		Spring Pre-Compression: in. (mm)	0.19 (4.83)	0.19 (4.83)	0.25 (6.35)	0.31 (7.87)	0.38 (9.65)	0.44 (11.18)	0.50 (12.70)	0.56 (14.22)					
	Stem Travel in (mm)	0.25 (6.35)	0.25 (6.35)	0.25 (6.35)	0.25 (6.35)	0.25 (6.35)	0.19 (4.83)	0.12 (3.05)	0.06 (1.52)						
	Heavy Duty	Air Pressure: psi (bar)	35 (2.41)	35 (2.41)	40 (2.76)	45 (3.10)	50 (3.45)	50 (3.45)	50 (3.45)	50 (3.45)					
20SM9 15P8†	Medium Duty	Air Pressure: psi (bar)	85 (5.86)	90 (6.21)	95 (6.55)	95 (6.55)								9,800 (675.68)	1.29 to 0.53***
		Spring Pre-Compression: in. (mm)	0.31 (7.87)	0.34 (8.64)	0.47 (11.94)	0.56 (14.22)									
		Stem Travel in (mm)	0.25 (6.35)	0.25 (6.35)	0.15 (3.81)	0.06 (1.52)									
	Heavy Duty	Air Pressure: psi (bar)	50 (3.45)	55 (3.79)	65 (4.48)	70 (4.83)	75 (5.17)	75 (5.17)	75 (5.17)					15,700 (1082.46)	1.29 to 0.53***
		Spring Pre-Compression: in. (mm)	0.19 (4.83)	0.22 (5.59)	0.28 (7.11)	0.34 (8.64)	0.44 (11.18)	0.50 (12.70)	0.56 (14.22)						
		Stem Travel in (mm)	0.25 (6.35)	0.25 (6.35)	0.25 (6.35)	0.25 (6.35)	0.19 (4.83)	0.12 (3.05)	0.06 (1.52)						
	Extra Heavy Duty Single Stage	Air Pressure: psi (bar)	40 (2.76)	40 (2.76)	50 (3.45)	55 (3.79)	60 (4.13)	65 (4.48)	70 (4.83)	75 (5.17)	85 (5.86)			20,000 (1378.93)	1.30
		Spring Pre-Compression: in. (mm)	0.25 (6.35)	0.28 (7.11)	0.38 (9.65)	0.47 (11.94)	0.56 (14.22)	0.66 (16.76)	0.75 (19.05)	0.84 (21.34)	0.94 (23.88)				
		Stem Travel in (mm)	0.38 (9.65)	0.38 (9.65)	0.38 (9.65)	0.38 (9.65)	0.38 (9.65)	0.38 (9.65)	0.38 (9.65)	0.38 (9.65)	0.38 (9.65)				
	Extra Heavy Duty Two Stage	Air Pressure: psi (bar)	30 (2.07)	35 (2.41)	35 (2.41)	40 (2.72)	40 (2.72)	45 (3.10)	50 (3.45)	50 (3.45)	55 (3.79)			20,000 (1378.93)	1.30
		Spring Pre-Compression: in. (mm)	0.13 (3.30)	0.16 (4.06)	0.19 (4.83)	0.25 (6.35)	0.28 (7.11)	0.34 (8.64)	0.38 (9.65)	0.44 (11.18)	0.47 (11.94)				
		Stem Travel in (mm)	0.38 (9.65)	0.38 (9.65)	0.38 (9.65)	0.38 (9.65)	0.38 (9.65)	0.38 (9.65)	0.38 (9.65)	0.38 (9.65)	0.38 (9.65)				

† Maximum rating is based on the valve rating.

*** Cv varies because of spring compression limitations. The flow coefficient range is given for the maximum stem travel (lowest system pressure) to minimum travel (highest system pressure).

Air-to-Open - Series 20SM Valves

Valve Series	Operator Duty	System Pressure KSI (Mpa)										Maximum Pressure psi (bar)*	Flow Coefficient Cv**	
		1-4 (6.89-27.58)	6 (41.37)	8 (55.15)	10 (68.95)	12 (82.74)	14 (96.53)	16 (110.31)	18 (124.10)	20 (137.89)				
20SM12 10P12†	Heavy Duty	Air Pressure: psi (bar)	65 (4.48)	75 (5.17)									6,000 (413.68)	0.80 to 0.78***
		Spring Pre-Compression: in. (mm)	0.28 (7.11)	0.38 (9.65)										
		Stem Travel in (mm)	0.25 (6.35)	0.25 (6.35)										
	Extra Heavy Duty Single Stage	Air Pressure: psi (bar)	50 (3.45)	60 (4.13)	70 (4.83)	80 (5.52)	90 (6.21)	100 (6.89)	100 (6.89)				15,000 (1034.19)	2.50
		Spring Pre-Compression: in. (mm)	0.38 (9.65)	0.50 (12.70)	0.66 (16.76)	0.81 (20.57)	0.97 (24.64)	1.13 (28.70)	1.22 (30.99)					
		Stem Travel in (mm)	0.44 (11.18)	0.44 (11.18)	0.44 (11.18)	0.44 (11.18)	0.44 (11.18)	0.44 (11.18)	0.44 (11.18)	0.44 (11.18)	0.44 (11.18)			
	Extra Heavy Duty Two Stage	Air Pressure: psi (bar)	40 (2.76)	45 (3.10)	50 (3.45)	55 (3.79)	60 (4.13)	65 (4.48)	70 (4.83)	75 (5.17)	80 (5.52)		20,000 (1378.93)	2.50
		Spring Pre-Compression: in. (mm)	0.19 (4.83)	0.25 (6.35)	0.31 (7.87)	0.41 (10.41)	0.50 (12.70)	0.56 (14.22)	0.66 (16.76)	0.72 (18.29)	0.81 (20.57)			
		Stem Travel in (mm)	0.44 (11.18)	0.44 (11.18)	0.44 (11.18)	0.44 (11.18)	0.44 (11.18)	0.44 (11.18)	0.44 (11.18)	0.44 (11.18)	0.44 (11.18)			
20SM16 10P16†	Heavy Duty	Air Pressure: psi (bar)	75 (5.17)										4,000 (275.79)	2.73 to .15***
		Spring Pre-Compression: in. (mm)	0.38 (9.65)											
		Stem Travel in (mm)	0.25 (6.35)											
	Extra Heavy Duty Single Stage	Air Pressure: psi (bar)	65 (4.48)	80 (5.52)	95 (6.55)	100 (6.89)							10,000 (689.46)	3.40
		Spring Pre-Compression: in. (mm)	0.50 (12.70)	0.75 (19.05)	0.97 (24.64)	1.22 (30.99)								
		Stem Travel in (mm)	0.50 (12.70)	0.50 (12.70)	0.50 (12.70)	0.50 (12.70)								
	Extra Heavy Duty Two Stage	Air Pressure: psi (bar)	50 (3.45)	55 (3.79)	65 (4.48)	70 (4.83)	80 (5.52)	85 (5.86)	90 (6.21)	100 (6.89)	100 (6.89)		20,000 (1378.93)	3.40
		Spring Pre-Compression: in. (mm)	0.25 (6.35)	0.38 (9.65)	0.50 (12.70)	0.63 (16.00)	0.75 (19.05)	0.84 (21.34)	0.97 (24.64)	1.09 (27.69)	1.22 (30.99)			
		Stem Travel in (mm)	0.50 (12.70)	0.50 (12.70)	0.50 (12.70)	0.50 (12.70)	0.50 (12.70)	0.50 (12.70)	0.50 (12.70)	0.50 (12.70)	0.50 (12.70)			

† Maximum rating is based on the valve rating.

** Cv data is for 2-way straight valves.
For angle pattern, add approximately 50% to the Cv valve.

*** Cv varies because of spring compression limitations. The flow coefficient range is given for the maximum stem travel (lowest system pressure) to minimum travel (highest system pressure).

CAUTION: While testing has shown O-rings to provide satisfactory service life, both cyclic and shelf life may vary widely with differing service conditions, properties of reactants, pressure and temperature cycling and age of the O-ring, FREQUENT INSPECTIONS SHOULD BE MADE to detect any deterioration, and O-rings replaced as required.

*Maximum pressure rating is based on the lowest rating of any component.
Actual working pressure may be determined by tubing pressure rating, if lower.

All dimensions for reference only and subject to change.

For prompt service, Parker Autoclave Engineers stocks select products. Consult your local representative.

Air-to-Open - Series 30SC Valves

Valve Series	Operator Duty		System Pressure KSI (Mpa)										Maximum Pressure psi (bar)*	Flow Coefficient Cv**	
			1-15 (6.89-103.42)	16 (110.31)	18 (124.10)	20 (137.89)	22 (151.68)	24 (165.47)	26 (179.26)	28 (193.05)	30 (206.84)				
30SC16	Extra Heavy Duty Two Stage	Air Pressure: psi (bar)	70 (4.83)	75 (5.17)	75 (5.17)	80 (5.52)	85 (5.86)	95 (6.55)	100 (6.89)	100 (6.89)	100 (6.89)			30,000 (2068.39)	2.61
		Spring Pre-Compression: in. (mm)	0.56 (14.22)	0.62 (15.75)	0.68 (17.27)	0.75 (19.05)	0.88 (22.35)	0.94 (23.88)	1.00 (25.40)	1.06 (26.92)	1.38 (35.05)				
		Stem Travel in (mm)	0.50 (12.70)	0.50 (12.70)	0.50 (12.70)	0.50 (12.70)	0.50 (12.70)	0.50 (12.70)	0.50 (12.70)	0.50 (12.70)	0.50 (12.70)	0.50 (12.70)			

Series 30VM Valves

Valve Series	Operator Duty		System Pressure KSI (Mpa)										Maximum Pressure psi (bar)*	Flow Coefficient Cv**	
			1-10 (6.89-68.95)	12 (82.74)	14 (96.53)	16 (110.31)	18 (124.10)	20 (137.89)	22 (151.68)	24 (165.47)	26 (179.26)	28 (193.05)			30 (206.84)
30VM4	Medium Duty	Air Pressure: psi (bar)	45 (3.10)	45 (3.10)	55 (3.79)	55 (3.79)	55 (3.79)	55 (3.79)	65 (4.48)	65 (4.48)	65 (4.48)	65 (4.48)	75 (5.17)	30,000 (2068.39)	0.12
		Spring Pre-Compression: in. (mm)	0.12 (3.15)	0.12 (3.05)	0.19 (4.83)	0.19 (4.83)	0.19 (4.83)	0.19 (4.83)	0.25 (6.35)	0.25 (6.35)	0.25 (6.35)	0.25 (6.35)	0.31 (7.87)		
	Stem Travel in (mm)	0.19 (4.83)	0.19 (4.83)	0.19 (4.83)	0.19 (4.83)	0.19 (4.83)	0.19 (4.83)	0.19 (4.83)	0.19 (4.83)	0.19 (4.83)	0.19 (4.83)	0.19 (4.83)	0.19 (4.83)		
30VM6 & 30VM9	Medium Duty	Air Pressure: psi (bar)	45 (3.10)	55 (3.79)	55 (3.79)	65 (4.48)	65 (4.48)	75 (5.17)	75 (5.17)	75 (5.17)	85 (5.86)	85 (5.86)	95 (6.55)	30,000 (2068.39)	0.33 (30VM6) 0.33 (30VM9)
		Spring Pre-Compression: in. (mm)	0.12 (3.05)	0.19 (4.83)	0.19 (4.83)	0.25 (6.35)	0.25 (6.35)	0.31 (7.87)	0.31 (7.87)	0.31 (7.87)	0.38 (9.65)	0.38 (9.65)	0.44 (11.18)		
	Stem Travel in (mm)	0.19 (4.13)	0.19 (4.83)	0.19 (4.83)	0.19 (4.83)	0.19 (4.83)	0.19 (4.83)	0.19 (4.83)	0.19 (4.83)	0.19 (4.83)	0.19 (4.83)	0.19 (4.83)	0.19 (4.83)		
30VM6 & 30VM9	Heavy Duty	Air Pressure: psi (bar)	25 (1.72)	30 (2.07)	30 (2.07)	35 (2.41)	35 (2.41)	40 (2.76)	40 (2.76)	40 (2.76)	45 (3.10)	45 (3.10)	50 (3.45)		

Series 40VM Valves

Valve Series	Operator Duty		System Pressure KSI (Mpa)										Maximum Pressure psi (bar)*	Flow Coefficient Cv**	
			1-10 (6.89-68.95)	15 (103.42)	20 (137.89)	25 (172.37)	30 (206.84)	35 (241.31)	40 (275.79)						
40VM9	Medium Duty	Air Pressure: psi (bar)	60 (4.13)	70 (4.83)	75 (5.17)	85 (5.86)	95 (6.55)	100 (6.89)	100 (6.89)					40,000 (2757.86)	0.28
		Spring Pre-Compression: in. (mm)	0.12 (3.05)	0.18 (4.57)	0.25 (6.35)	0.31 (7.87)	0.38 (9.65)	0.43 (10.92)	0.5 (12.70)						
	Stem Travel in (mm)	0.25 (6.35)	0.25 (6.35)	0.25 (6.35)	0.25 (6.35)	0.25 (6.35)	0.25 (6.35)	0.25 (6.35)							
40VM9	Heavy Duty	Air Pressure: psi (bar)	30 (2.07)	35 (2.41)	40 (2.76)	45 (3.10)	50 (3.45)	50 (3.45)	55 (3.79)						

Air-to-Open - Series 60VM Valves

Valve Series	Operator Duty		System Pressure KSI (Mpa)										Maximum Pressure psi (bar)*	Flow Coefficient Cv**
			1-15 (6.89-103.42)	20 (137.89)	25 (172.37)	30 (206.84)	35 (241.31)	40 (275.79)	45 (310.26)	50 (344.73)	55 (379.21)	60 (413.68)		
60VM4 & 60VM6	Medium Duty	Air Pressure: psi (bar)	55 (3.79)	65 (4.48)	65 (4.48)	65 (4.48)	75 (5.17)	75 (5.17)	85 (5.86)	85 (5.86)	85 (5.86)	95 (6.55)	60,000 (4136.79)	0.08 (60VM4)
		Spring Pre-Compression: in. (mm)	0.12 (3.05)	0.19 (4.83)	0.19 (4.83)	0.19 (4.83)	0.25 (6.35)	0.25 (6.35)	0.31 (7.87)	0.31 (7.87)	0.31 (7.87)	0.38 (9.65)		
		Stem Travel in (mm)	0.25 (6.35)	0.25 (6.35)	0.25 (6.35)	0.25 (6.35)	0.25 (6.35)	0.25 (6.35)	0.25 (6.35)	0.25 (6.35)	0.25 (6.35)	0.25 (6.35)		
	Heavy Duty	Air Pressure: psi (bar)	30 (2.07)	35 (2.41)	35 (2.41)	35 (2.41)	40 (2.76)	40 (2.76)	45 (3.10)	45 (3.10)	45 (3.10)	50 (3.45)		
60VM9	Medium Duty	Air Pressure: psi (bar)	55 (3.74)	65 (4.42)	65 (4.42)	75 (5.10)	75 (5.10)	85 (5.78)	95 (6.46)	95 (6.46)	95 (6.46)	95 (6.46)	60,000 (4136.79)	0.14
		Spring Pre-Compression: in. (mm)	0.12 (3.05)	0.19 (4.83)	0.19 (4.83)	0.25 (6.35)	0.25 (6.35)	0.31 (7.87)	0.38 (9.65)	0.38 (9.65)	0.44 (11.18)	0.50 (12.70)		
		Stem Travel in (mm)	0.25 (6.35)	0.25 (6.35)	0.25 (6.35)	0.25 (6.35)	0.25 (6.35)	0.25 (6.35)	0.25 (6.35)	0.25 (6.35)	0.19 (4.83)	0.12 (3.05)		
	Heavy Duty	Air Pressure: psi (bar)	30 (2.07)	35 (2.41)	35 (2.41)	40 (2.76)	40 (2.76)	45 (3.10)	50 (3.45)	50 (3.45)	50 (3.45)	50 (3.45)		

Series 100VM and 150V Valves

Valve Series	Operator Duty		System Pressure KSI (Mpa)										Maximum Pressure psi (bar)*	Flow Coefficient Cv**
			1-20 (6.89-137.89)	40 (275.79)	60 (13.68)	80 (551.57)	90 (620.52)	100 (689.46)	125 (861.83)	150 (1034.20)				
100VM4 100VM5 100VM6	Heavy Duty	Air Pressure: psi (bar)	35 (2.41)	40 (2.76)	50 (3.45)	60 (4.14)	70 (4.83)	70 (4.83)					100,000 (6894.65)	0.09 to 0.07***
		Spring Pre-Compression: in. (mm)	0.12 (3.05)	0.19 (4.83)	0.25 (6.35)	0.31 (7.87)	0.38 (9.65)	0.38 (9.65)						
		Stem Travel in (mm)	0.12 (3.05)	0.12 (3.05)	0.12 (3.05)	0.12 (3.05)	0.12 (3.05)	0.12 (3.05)						
150V5	Heavy Duty	Air Pressure: psi (bar)	30 (2.07)	40 (2.76)	45 (3.10)	55 (3.79)	60 (4.13)	60 (4.13)	70 (4.83)	75 (5.17)			150,000 (10341.97)	0.06
		Spring Pre-Compression: in. (mm)	0.12 (3.05)	0.19 (4.83)	0.25 (6.35)	0.31 (7.87)	0.38 (9.65)	0.38 (9.65)	0.44 (11.18)	0.56 (14.22)				
		Stem Travel in (mm)	0.12 (3.05)	0.12 (3.05)	0.12 (3.05)	0.12 (3.05)	0.12 (3.05)	0.12 (3.05)	0.12 (3.05)	0.06 (1.52)				

** C_v data is for 2-way straight valves.
For angle pattern, add approximately 50% to the C_v valve.

*** C_v varies because of spring compression limitations. The flow coefficient range is given for the maximum stem travel (lowest system pressure) to minimum travel (highest system pressure).

CAUTION: While testing has shown O-rings to provide satisfactory service life, both cyclic and shelf life may vary widely with differing service conditions, properties of reactants, pressure and temperature cycling and age of the O-ring. FREQUENT INSPECTIONS SHOULD BE MADE to detect any deterioration, and O-rings replaced as required.

*Maximum pressure rating is based on the lowest rating of any component.
Actual working pressure may be determined by tubing pressure rating, if lower.

All dimensions for reference only and subject to change.

For prompt service, Parker Autoclave Engineers stocks select products. Consult your local representative.