

Needle Valves

Block and Bleed

MVBB Series

Pressures to 20,000 psi (1379 bar)

Parker Autoclave Engineers series MVBB block and bleed valve is a two stem manifold valve providing an economical and convenient method of blocking, bleed-off and calibrating pressure transmitters and gauges. The valve utilizes the mini valve packing and stem design making it compact and easy to use. The valve can be surface or panel mounted for safe operation. In addition, manifold style valves reduce the number of fittings and space required for installation.

Block and Bleed Features:

- MVBB Series valve design provides large valve performance in a small package
- Tubing sizes: 1/4" and 3/8"
- Rising stem/barstock body design.
- Metal-to-metal seating achieves bubble-tight shut-off, longer stem/seat life in abrasive flow, greater durability for repeated on/off cycles and excellent corrosion resistance.
- PTFE encapsulated packing provides dependable stem and body sealing.
- Stem and packing gland design have been selected to achieve extended thread cycle life and reduced handle torque.

Parker Autoclave Engineers valves are complemented by a complete line of fittings, tubings and accessories. The MVBB Series uses Parker Autoclave Engineers' medium pressure connections. This coned and threaded connection provides a reliable bubble-tight seal for dependable performance in gas or liquid service.



Needle Valves - MVBB Series
Block and Bleed



Autoclave Engineers 
www.autoclave.com

Needle Valves - MVBB Series

Pressures to 20,000 psi (1379 bar)

Tube Outside Diameter Size Inches	Connection Type	Orifice Size Inches (mm)	Rated C_v	Pressure Rating psi (bar) @ Room Temperature**
1/4	SF250CX	0.093 (2.36)	0.20	20,000 (1379)
3/8	SF375CX	0.093 (2.36)	0.20	20,000 (1379)

Notes:

** For complete temperature ratings see pressure/temperature rating guide in Technical Information section.

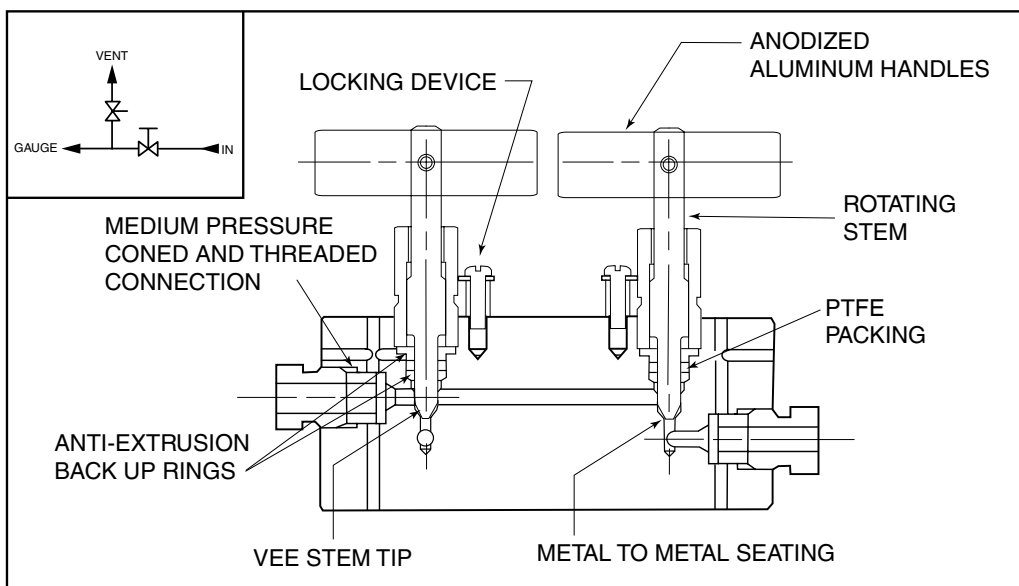

To ensure proper fit use Autoclave tubing

Valve Options

Extreme Temperatures

Standard Parker Autoclave Engineers valves with PTFE packing may be operated to 450°F (232°C). High temperature packing is available for service from 0°F (-17.8°C) to 800°F (427°C) by adding the following suffixes to catalog order number.

TG standard valve with PTFE glass packing to 600°F (316°C)

GY standard valve with Graphite braided yarn packing to 800°F (427°C).

For additional valve options, contact your Sales Representative.

Note: Refer to the Tools, Installation, Operation and Maintenance section for proper maintenance procedures.

Catalog Number	Stem Type	Outside Diameter Tube	Orifice Diameter	Dimensions - inches (mm)														
				A	B	C	D	D ₁	E	F	G	G ₁	H*	M	N	O	P	Q
20MVBB4	VEE	1/4	0.094	3.50	0.813	0.38	0.625	0.938	1.50	1.75	0.56	0.281	2.94	2.50	0.485	1.63	.500	2.625
		(6.35)	(2.39)	(88.90)	(20.65)	(9.65)	(15.88)	(23.83)	(38.10)	(44.45)	(14.27)	(7.14)	(74.68)	(63.50)	(12.32)	(41.40)	12.70	66.68
20MVBB6	VEE	3/8	0.094	3.88	1.00	0.44	0.625	0.938	1.50	1.75	0.56	0.281	2.94	2.88	0.50	1.63	.500	2.625
		(9.53)	(2.39)	(98.60)	(25.40)	(11.10)	(15.88)	(23.83)	(38.10)	(44.45)	(14.27)	(7.14)	(74.68)	(73.15)	(12.70)	(41.40)	12.70	66.68

For complete information on available options, contact your Sales representative. MVBB Series valves are furnished with connection components unless otherwise specified.

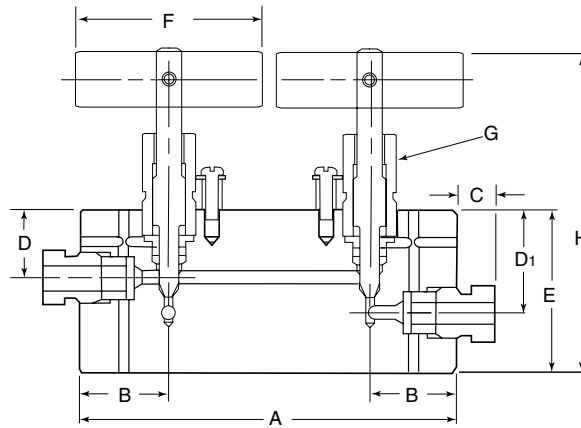
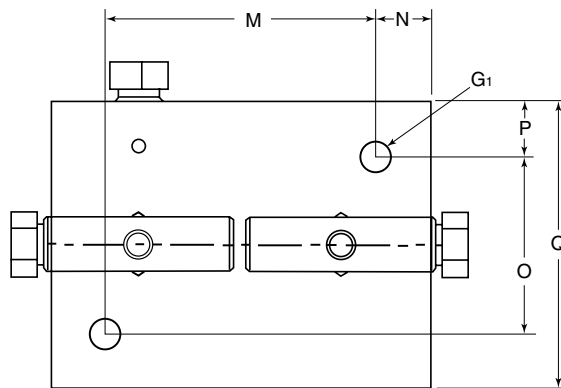

G - Packing gland mounting hole drill size
G₁ - Bracket mounting hole size

* H Dimension is with stem in closed position.
All dimensions for reference only and subject to change.

**For prompt service, Parker
Autoclave Engineers stocks
select products.
Consult factory.**