



Step Motor Expansion Valves

Types SERI-F, -G(S), -J(S), -K(S), -L(S) – PED Cat. II

Installation and Servicing Instructions
SD-457 / 32025



The Sporlan SERI valves are stepper motor driven Electric Expansion Valves (EEV), featuring:

- High resolution actuators
- High linear force output
- Exceptional flow control across widely varying conditions
- Tight seating
- Bi-directional flow capability
- Field proven reliability
- Serviceable motor assemblies
- Removable IP-67 M12 cables (A-coded)
- 12VDC (Pulsed Signal)

APPLICATION

- Refer to Bulletin 100-20 for all models covered by these instructions.
- The above EEV valves are designed for use with A2, A2L and A3 (flammable) refrigerants such as Fluorocarbons and Hydrocarbons.
- The intended design life of the Electric Expansion Valve is 15 years, providing that the valve is installed and operated within the design intent and the system is free from contaminants. The intended life expectancy is not to be construed or used as a Parker Hannifin warranty. The Parker Hannifin User Responsibility Statement and Offer of Sale specify terms and conditions, including the standard product warranty and liability.

SPECIAL CONDITIONS OF USE AND SAFETY

- To avoid electrostatic charging and/or electrical shock, steps must be taken to ensure equipotential bonding is maintained through all isolated parts, and the equipment is earth bonded via the valve's connections. Isolation of conductive parts will cause an ignition hazard. Power shall not be applied to the valve until adequate ground bonding is maintained.
- The cable should not be removed from the valve when energized.
- The valve must be protected from external impact that may cause a spark.
- Personnel handling or working on or with this product must be qualified for that task.
- This valve has not been designed for use with fluids outside Fluid Groups 1 and 2. Refer to the manufacturer for specific fluids for which this valve has been approved.
- No pressure limiting devices have been included in the design. It is the user's responsibility to ensure pressures will not permanently exceed maximum allowable pressure PS, and that devices adequate to protect against pressure surges greater than 1.1xPS are installed prior to first use.
- It is the responsibility of the installer to check that there is no leakage after installation, especially in case of potentially explosive atmospheres.
- The valve and its control must not undergo any modification without prior approval from the equipment manufacturer or Parker Hannifin, Sporlan Division.
- Parker Hannifin, Sporlan Division is not responsible for any damage which may be caused by misuse or by installation of parts, accessories or controls which are not on the original specification.
- Hot or cold parts of the valve which present a danger to the operator must be protected.

MAINTENANCE, INSTALLATION AND SERVICE

- Only authorized persons who are certified in installing and maintaining refrigeration and air conditioning systems containing flammable refrigerants may do the installation and maintenance.
- All local requirements or codes regarding use of flammable refrigerants in refrigeration and air conditioning systems must be followed.

- The refrigeration or air conditioning system must be designed so no abnormal impact (vibration, liquid hammer, pressure pulsations) can create risk for damage to the system.
- When replacing parts, only use identical replacement parts or previously authorized substitutes.
- Parker Hannifin, Sporlan Division takes no responsibility for the classification of the refrigeration and/or air conditioning system.

NEW INSTALLATION STEPS

1. Braze or solder the inlet and outlet connections using standard practices and materials. See Figure 1. It is not necessary to remove the motor assembly or cable during valve installation, but the cable should be routed to avoid direct or indirect damage from overheating.

NOTE: If the cable is removed, the electrical connection should be protected to prevent introduction of moisture.

NOTE: Care must be taken to ensure that the valve internal temperature does not reach 60°C (250°F).

2. If a cable is not already attached to the valve, attach an M12 A-coded cable and hand-tighten the nut, using care to avoid twisting the cable itself. A torque of 10-14 in./lbs. will ensure compliance with an IP67 rating.

NOTE: Orientation of the cable is not relevant to valve performance. If the plastic insert with the keyway is removed, it can be reinstalled in any of four orientations without affecting performance.

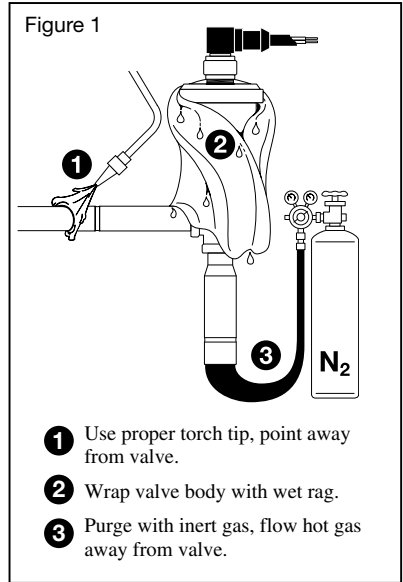

- 1 Use proper torch tip, point away from valve.
- 2 Wrap valve body with wet rag.
- 3 Purge with inert gas, flow hot gas away from valve.

BIPOLAR DRIVE SEQUENCE				
STEP	BLACK	WHITE	RED	GREEN
1	12 volts	0 volts	12 volts	0 volts
2	0 volts	12 volts	12 volts	0 volts
3	0 volts	12 volts	0 volts	12 volts
4	12 volts	0 volts	0 volts	12 volts
1	12 volts	0 volts	12 volts	0 volts

OPEN
↓

↑
CLOSE

3. Wire the valve cable to the controller according to the controller specifications. The required valve drive sequence is shown below for reference.
4. Apply power to the valve controller. The valve is shipped at approximately half stroke, so the controller will overdrive closed to establish the zero position. A light clicking may be heard during this time. Upon completion of initialization, the valve should be ready to begin controlling.

FIELD SERVICE INSTRUCTIONS

1. If the valve fails to operate properly, disconnect the line voltage from the valve controller. Disconnect the valve leads from the controller.
2. Check the resistance of each motor phase. The resistance between either the black and white or red and green leads should be approximately 100Ω at 22°C (72°F). Differences of more than 10% between phases may indicate a defective motor, and the motor adapter assembly should be replaced.
3. Check to ensure that resistance between any lead and the valve body is greater than 1MΩ. Lower resistance readings may indicate a short, and the motor adapter assembly should be replaced.
4. If you have access to a Sporlan SMA-12 test instrument, functionality of the valve can be determined before removal from the system by monitoring changes in system conditions as valve position is changed or by visually verifying piston movement in the sight glass. If normal function can be verified by manually positioning the valve, proper controller functionality should be investigated.

NOTE: Care should be taken to assure that damage to the system does not occur during a manual positioning test due to an improperly positioned valve.
5. Prior to removing a valve or motor adapter assembly, make sure the refrigerant has been properly

recovered and pressure has been reduced to a safe level (0 psig). Follow local, state, and federal laws for refrigerant recovery.

WARNING: The area should be vented thoroughly to prevent accumulation of flammable vapor.

- Using an SMA-12 or the manual positioning capability of the valve controller, retract the piston (open the valve).

NOTE: Removing the motor adapter assembly with the piston fully extended (valve closed) may cause permanent damage to the piston assembly.

- Refer to the exploded view of the valve prior to disassembly. Using a wrench or fixture to support the valve body, remove the motor assembly using a slimline wrench (such as Snap-on LTA4042 or Martin MRT1240).

- If you have access to a Sporlan SMA-12 test instrument, functionality of the valve can be visually confirmed by watching the piston extend and retract.

NOTE: Be careful when extending the valve piston to avoid accidentally driving the piston out of the adapter housing. If removed, extreme care should be taken to ensure that the piston seal is not damaged during reinstallation of the piston.

- The original or a replacement motor adapter assembly can be reinstalled into the existing valve body. Lightly oil the gasket and thread the motor adapter assembly into the valve body. Tighten the adapter to a torque of 30-35 ft./lb.

NOTE: If the piston is extended while the motor adapter assembly is removed from the valve, it must be retracted prior to reinstalling in the system. Failure to retract the piston (open the valve) prior to installation may cause permanent damage to the piston assembly.

NOTE: Service kits are shipped at approximately half stroke, and do not need to be moved prior to installation.

- Pressurize the system and check for leaks.

NOTE: It is the responsibility of the installer to check that there is no leakage after installation, especially in case of potentially explosive atmospheres.

- Reconnect the cable to the controller according to the controller specifications and reapply power. The valve will initialize and then resume normal operation.

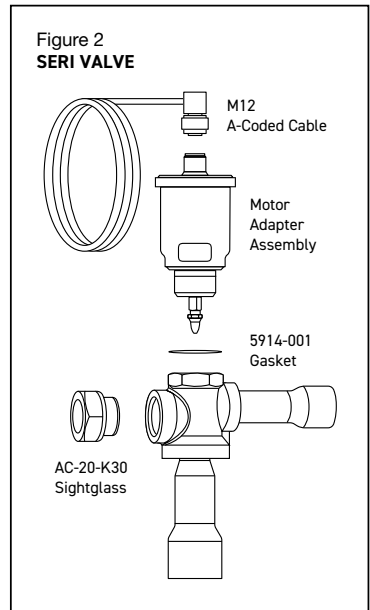

EUROPEAN FLAMMABLE REFRIGERANT AND FLAMMABLE ATMOSPHERE COMPLIANCE

The products marked within this Bulletin are designed to be used with A2L, A2, and A3 flammable refrigerants. These products comply with the “Pressure Equipment Directive” (2014/68/EU).

Products bearing the CE mark have been certified to meet the appropriate category requirements.

Products falling under Sound Engineering Practice (SEP) have been verified to comply however do not receive the CE mark as stated in the Pressure Equipment Directive referenced above.

All local requirements or codes regarding use of flammable refrigerants in refrigeration and air-conditioning systems must be followed.

PED NAMEPLATE DATA

TYPE	DESCRIPTION	MAX. RATED PRESSURE (BAR)	TS (°C)	FLUID CAPACITY (L)	DN	CATEGORY FOR GROUP 1 FLUIDS
SERI-F	SERI-F 5X5 ODF	48.0	-45°C to 60°C	0.07	10	SEP
	SERI-F 5X7 ODF			0.08	20	SEP
	SERI-F 7X4 ODF			0.07	20	SEP
	SERI-F 7X7 ODF			0.08	20	SEP
	SERI-F 7X9 ODF			0.10	25	SEP

PED NAMEPLATE DATA (Continued)

TYPE	DESCRIPTION	MAX. RATED PRESSURE (BAR)	TS (°C)	FLUID CAPACITY (L)	DN	CATEGORY FOR GROUP 1 FLUIDS
SERI-G(S)	SERI-G 5X5 ODF	48.0	-45°C to 60°C	0.06	10	SEP
	SERI-G 5ODFX5ODM			0.06	10	SEP
	SERI-G 5X7 ODF			0.07	20	SEP
	SERI-G 7X4 ODF			0.06	20	SEP
	SERI-G 7X9 ODF			0.09	25	SEP
	SERI-G 9X7 ODF			0.09	25	SEP
	SERI-G(S) 5X5 ODF			0.08	10	SEP
	SERI-G(S) 5X7 ODF			0.09	20	SEP
	SERI-G(S) 7X7 ODF			0.10	20	SEP
	SERI-G(S) 7X9 ODF			0.11	25	SEP
	SERI-G(S) 7X11 ODF			0.13	32	Category II
SERI-J(S)	SERI-J 7X5 ODF	48.0	-45°C to 60°C	0.08	20	SEP
	SERI-J 7X7 ODF			0.10	20	SEP
	SERI-J 7X9 ODF			0.11	25	SEP
	SERI-J 7X11 ODF			0.12	32	Category II
	SERI-J 9X5 ODF			0.10	25	SEP
	SERI-J 9X7 ODF			0.11	25	SEP
	SERI-J 9X9 ODF			0.12	25	SEP
	SERI-J 9X11 ODF			0.14	32	Category II
	SERI-J(S) 7X7 ODF			0.10	20	SEP
	SERI-J(S) 7X9 ODF			0.11	25	SEP
	SERI-J(S) 7X11 ODF			0.13	32	Category II
	SERI-J(S) 9X9 ODF			0.13	25	SEP
	SERI-J(S) 9X11 ODF			0.14	32	Category II
SERI-K(S)	SERI-K 9X6 ODF	48.0	-45°C to 60°C	0.13	25	SEP
	SERI-K 9X7 ODF			0.14	25	SEP
	SERI-K 9X9 ODF			0.16	25	SEP
	SERI-K 9X11 ODF			0.17	32	Category II
	SERI-K 9X13 ODF			0.19	40	Category II
	SERI-K(S) 9X9 ODF			0.18	25	SEP
	SERI-K(S) 9ODFx9ODM			0.17	25	SEP
	SERI-K(S) 9X11 ODF			0.20	32	Category II
	SERI-K(S) 9ODFX11ODM			0.19	32	Category II
	SERI-K(S) 9X13 ODF			0.22	40	Category II
	SERI-K(S) 11X13 ODF			0.24	40	Category II
	SERI-L(S)			SERI-L 9X9 ODF	48.0	-45°C to 60°C
SERI-L 9X11 ODF		0.18	32	Category II		
SERI-L 9X13 ODF		0.20	40	Category II		
SERI-L 11X11 ODF		0.19	32	Category II		
SERI-L 11X13 ODF		0.21	40	Category II		
SERI-L(S) 9X9 ODF		0.18	25	SEP		
SERI-L(S) 9X11 ODF		0.20	32	Category II		
SERI-L(S) 9ODFX11ODM		0.19	32	Category II		
SERI-L(S) 9X13 ODF		0.23	40	Category II		
SERI-L(S) 11ODFX9ODM		0.19	32	Category II		
SERI-L(S) 11X11 ODF		0.22	32	Category II		
SERI-L(S) 11X13 ODF		0.24	40	Category II		
"SERI-L(S) 13ODFX17ODM		0.30	50	Category II		

⚠WARNING – USER RESPONSIBILITY

Failure or improper selection or improper use of the products described herein or related items can cause death, personal injury and property damage. This document and other information from Parker Hannifin Corporation, its subsidiaries and authorized distributors provide product or system options for further investigation by users having technical expertise.

The user, through its own analysis and testing, is solely responsible for making the final selection of the system and components and assuring that all performance, endurance, maintenance, safety and warning requirements of the application are met. The user must analyze all aspects of the application, follow applicable industry standards, and follow the information concerning the product in the current product catalog and in any other materials provided from Parker or its subsidiaries or authorized distributors.

To the extent that Parker or its subsidiaries or authorized distributors provide component or system options based upon data or specifications provided by the user, the user is responsible for determining that such data and specifications are suitable and sufficient for all applications and reasonably foreseeable uses of the components or systems.

