



# Step Motor Expansion Valves

Type SEH

Installation and Servicing Instructions  
SD-401/52025



The Sporlan SEH valves are stepper motor driven Electric Expansion Valves (EEV), featuring:

- Largest flow capacity
- High resolution actuators
- Field proven reliability
- Tight seating
- Excellent corrosion resistance

## INSTALLATION INSTRUCTIONS

1. Braze or solder the inlet and outlet connections using standard practices and materials. See Figure 1.

**NOTE:** It is not necessary to remove the motor assembly during installation, however valve internal temperature must not reach 250°F (120°C).

**NOTE:** Care must be taken to prevent damaging the motor cable from excessive heat, either directly from the torch, or indirectly from contact with a hot surface.

2. Pressurize the system and check for leaks. If a cable is not already attached to the valve, attach an M12 A-coded cable and handtighten the nut using care to avoid twisting the cable itself. A torque of 10-14 in.-lb. is recommended.
3. The valve will only operate when connected to a properly designed and configured controller. Wire the valve cable to the controller according to the controller specifications. The required valve drive sequence is shown here for reference.

Figure 1

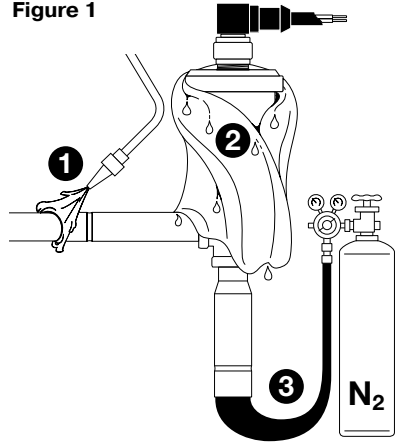

- 1 Use proper torch tip, point away from valve.
- 2 Wrap valve body with wet rag.
- 3 Purge with inert gas, flow hot gas away from valve.

### BIPOLAR DRIVE SEQUENCE

STEP	BLACK	WHITE	RED	GREEN
1	12 volts	0 volts	12 volts	0 volts
2	0 volts	12 volts	0 volts	12 volts
3	0 volts	12 volts	0 volts	12 volts
4	12 volts	0 volts	0 volts	12 volts
1	12 volts	0 volts	12 volts	0 volts

OPEN  
↓

↑  
CLOSE

4. Apply power to the valve controller. The valve is shipped at approximately half stroke, so the controller will overdrive closed to establish the zero position. A light clicking may be heard during this time. Upon completion of initialization, the valve should be ready to begin controlling.

## FIELD SERVICE INSTRUCTIONS

1. If the valve fails to operate properly, disconnect the line voltage from the valve controller. Disconnect the valve leads from the controller.
2. Check the resistance of each motor phase. The resistance between either the black and white or red and green leads should be approximately  $75\Omega$  at  $72^\circ\text{F}$  ( $22^\circ\text{C}$ ). Differences of more than 10% between phases may indicate a defective motor, and the motor adapter assembly should be replaced.
3. Check to ensure that resistance between any lead and the valve body is greater than  $1\text{M}\Omega$ . Lower resistance readings may indicate a short, and the motor adapter assembly should be replaced.
4. If you have access to a Sporlan SMA-12 test instrument, functionality of the valve can be determined before removal from the system by monitoring changes in system conditions as valve position is changed, or by visually verifying piston movement in the sight glass (if available). If normal function can be verified by manually positioning the valve, proper controller functionality should be investigated.

**NOTE:** Care should be taken to assure that damage to the system does not occur during a manual positioning test due to an improperly positioned valve.

5. Prior to removing a valve or motor adapter assembly, make sure the refrigerant has been properly recovered and pressure has been reduced to a safe level (0 psig).
6. Using an SMA-12 or the manual positioning capability of the valve controller, retract the piston (open the valve).

**NOTE:** Removing the motor adapter assembly with the piston fully extended (valve closed) may cause permanent damage to the piston assembly.

7. Refer to the exploded view of the valve prior to disassembly. Using appropriate wrenches or fixtures to support the valve body, remove the motor adapter assembly from the valve body using the hex flats.

**NOTE:** Do not attempt to disassemble the motor assembly, or separate the motor from the adapter. Either of these actions will result in permanent damage to the assembly.

**NOTE:** The adapter is very tight on the valve body. Use properly sized tools, and make sure to support the valve body well to avoid damaging the valve or surrounding piping.

8. If you have access to a Sporlan SMA-12 test instrument, functionality of the valve can be visually confirmed by watching the piston extend and retract into the adapter housing.

**NOTE:** Be careful when extending the valve piston to avoid accidentally driving the piston out of the adapter housing. If removed, extreme care should be taken to ensure that the piston seal is not damaged during reinstallation of the piston.

9. The original or a replacement motor adapter assembly can be reinstalled into the existing valve body. Lightly oil the gasket (-P, -400 or -T) or knife edge joint (-100 or -175), and thread the motor adapter assembly into the valve body. Tighten the adapter to the following specifications:

**NOTE:** If the piston is extended while the motor adapter assembly is removed from the valve, it must be retracted prior to reinstalling in the system. Failure to retract the piston (open the valve) prior to installation may cause permanent damage to the piston assembly.

Valve Model	Torque Specification
-100,-175	1/8 Turn Past Hand Tight
-P, -400	65-ft. lb.
-T	85-ft lb.

**NOTE:** Service kits are shipped at approximately half stroke, and do not need to be moved prior to installation.

10. Replacement motor adapter assemblies may not be shipped with full length cables. Butt splices are provided to tie into the existing valve cable.

**NOTE:** Color coding on the individual wires must be matched. Failure to do so may affect proper valve performance, or even damage the valve or controller.

**NOTE:** Cable splices must be properly installed and protected from moisture to ensure the quality of the signal from the controller to the valve.

11. Pressurize the system and check for leaks.
12. Reconnect the cable to the controller according to the controller specifications, and reapply power. The valve will initialize, and then resume normal operation.

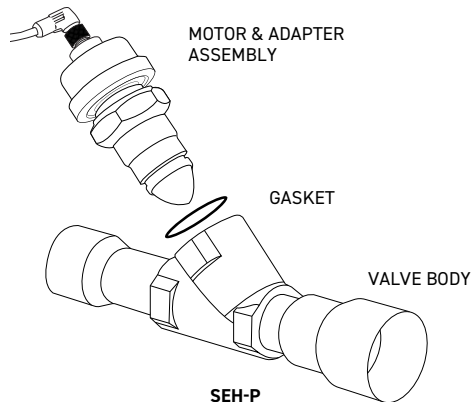
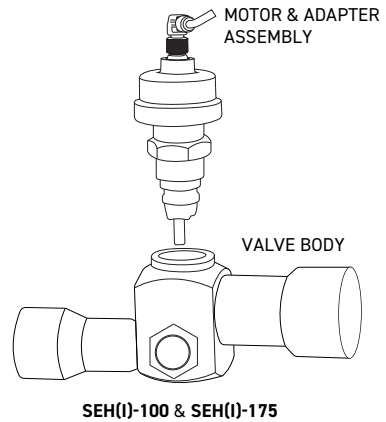
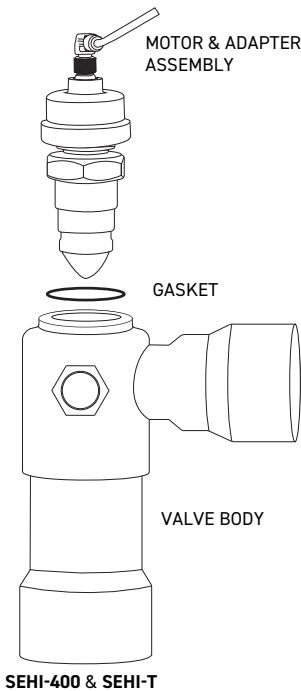

 **WARNING - USER RESPONSIBILITY**

**Failure or improper selection or improper use of the products described herein or related items can cause death, personal injury and property damage.**

This document and other information from Parker Hannifin Corporation, its subsidiaries and authorized distributors provide product or system options for further investigation by users having technical expertise.

The user, through its own analysis and testing, is solely responsible for making the final selection of the system and components and assuring that all performance, endurance, maintenance, safety and warning requirements of the application are met. The user must analyze all aspects of the application, follow applicable industry standards, and follow the information concerning the product in the current product catalog and in any other materials provided from Parker or its subsidiaries or authorized distributors.

To the extent that Parker or its subsidiaries or authorized distributors provide component or system options based upon data or specifications provided by the user, the user is responsible for determining that such data and specifications are suitable and sufficient for all applications and reasonably foreseeable uses of the components or systems.

**FOR USE ON REFRIGERATION and/or AIR CONDITIONING SYSTEMS ONLY**

