

Turbine FV Series - Single

Installation and Service Instructions

- Read all instructions before beginning installation. Improper installation could cause personal injury or property damage.
- Mounting fasteners and inlet/outlet port fittings not included.

Specifications: Diesel Applications

Height: 900FV: 17.12" (43.47 cm)
1000FV: 22.23" (56.47 cm)

Width: 8.86" (22.0 cm)

Depth: 7.96" (20.22 cm)

Ports: 1-5/16"-12 UN-2B (SAE 1926-1)
2X Plugs Supplied
2X 3/4" NPTF Adapters Supplied

Service Clearance (Top) 900FV: 5.0" (12.70 cm)
1000FV: 10.0" (25.40 cm)

Vacuum Installation Recommended
Maximum Head Pressure: 15 psi (1.03 bar)

- Mount assembly as close to vertical as possible. Do not exceed 10° from vertical or the assembly may not function properly.

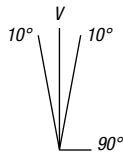

Valve Orientation:

CLOSED

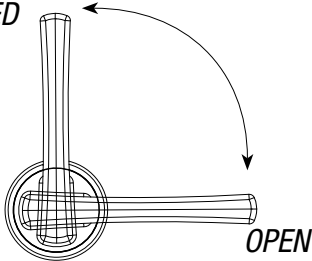

Valve orientation: Fuel flow is stopped when valve is in vertical position. Fuel flow is open in horizontal position. Element is serviced in closed position.

Mounting Information:

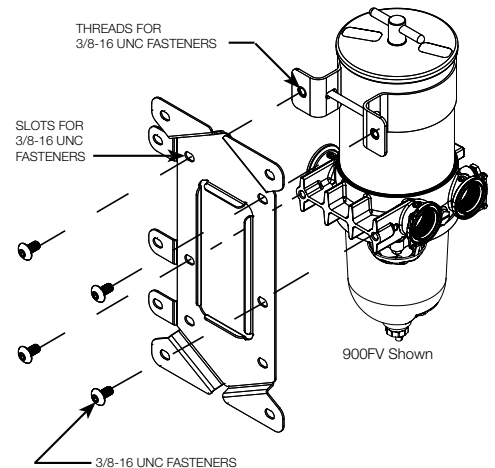
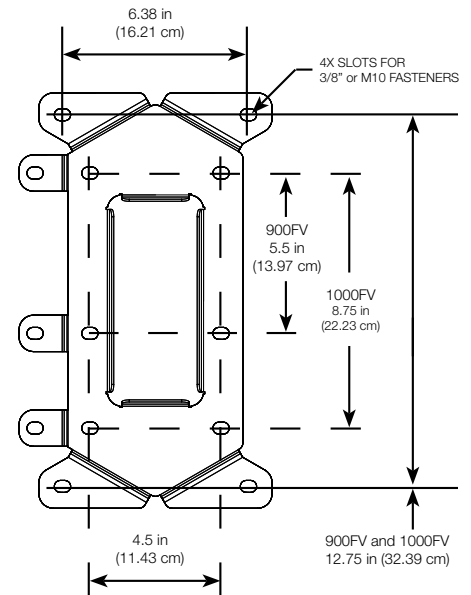
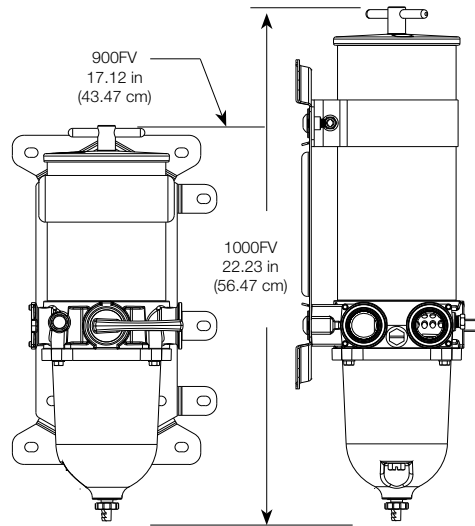
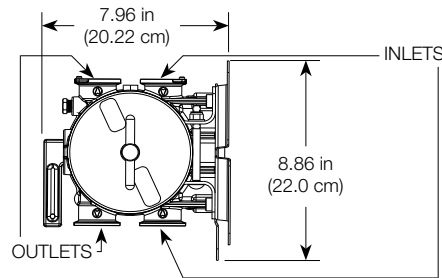

Tighten fasteners to 130 - 160 IN LBS

Service Filters:

900FV: 2040V2, 2040V10, or 2040V30
1000FV: 2020V2, 2020V10, or 2020V30

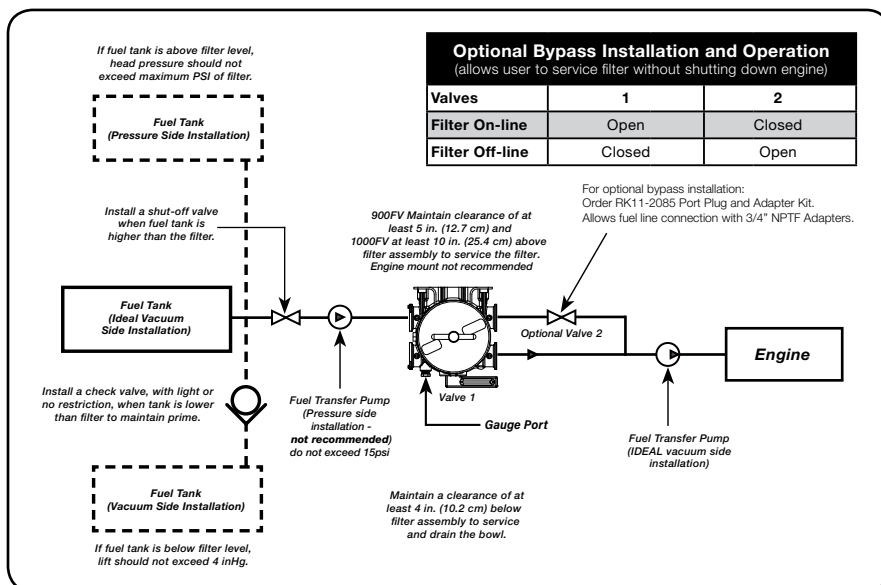

Getting Started

- Obtain good ventilation and lighting.
- Maintain a safe working environment.
- The engine must be off for installation.
- DO NOT smoke or allow open flames near the installation.

The following customer supplied materials should be on-hand before beginning installation.

- Shop Towels
- Diesel Fuel (about 1 gallon)
- Thread Sealant (no thread tapes)
- Parker Super O-Lube (RK 31605) or equivalent
- Fuel Hose
- 3/4" NPTF or 1 5/16"-12 UN-2B (SAE 1926-1) Hose Fitting

Installation Instructions

Positioning Filter

Install the Turbine Series filter on the vacuum side of the fuel transfer pump for optimum water separating efficiency.

Keep fuel line restrictions to a minimum. Locate the filter assembly between the horizontal planes of the bottom of the fuel tank and the inlet of the fuel pump, if possible.

Installing Filter

Completely remove any vacuum side filters in the fuel line between the fuel tank and the fuel pump. This is where the filter assembly will be mounted. Leaving these filters in place will add to the fuel line restriction. Filter heads cast into the engine, or that are non-removable, or hard-piped, should be serviced with a new filter and left in place.

- Always use the maximum size fuel hose possible.
- Do not make sharp bends with flexible fuel hose as kinks may occur.
- Avoid the use of two 45° elbow fittings where one 90° elbow will work.

- When routing hose, avoid surfaces that move, have sharp edges, or get hot (such as exhaust piping).

Priming Instructions

1. Verify valve is in closed position.
2. Remove T-handle and lid from top of filter. Verify correct element is installed. Fuel will not flow if element is not installed.
3. Fill filter housing with clean diesel fuel.
4. Lubricate lid gasket and T-handle O-ring with Parker O-lube, clean fuel, or motor oil.
5. Replace lid and T-handle and tighten snugly by hand only—do not use tools.
6. If applicable, refer to equipment Operator's Service Manual to complete fuel priming procedure.
7. Verify valve is in open position.
8. Start engine and check for fuel system leaks. Correct as necessary with engine off and pressure relieved from filter assembly.

Service Instructions

Draining Water

Frequency of water draining is determined by the contamination level of fuel. Inspect or drain collection bowl of water daily or as necessary. Collection bowl must be drained before contaminants reach the top of the turbine or when the Water Detection Module (optional) indicates draining is required.

Vacuum Side Applications

1. Close inlet valve (or valve #1) and open self-venting drain on bottom of bowl.
2. Close drain after all water and contaminants have been evacuated. DO NOT leave drain open too long as it will eventually completely drain the entire filter of water AND fuel.
3. Follow Priming Instructions.

Pressure Side Applications

1. Open self-venting drain on bottom of bowl. Head pressure will push any water and contaminants out of drain while keeping filter primed.

2. Close drain after all water and contaminants have been evacuated. DO NOT leave drain open too long as it will eventually completely drain entire filter of water AND fuel, and possibly drain entire tank.

Filter Changes

Frequency of filter replacement is determined by the contamination level of the fuel. Replace filter every 10,000 miles, every 500 hours, every other oil change, when vacuum gauge (optional) reads between 6 to 10 inches of mercury (inHg), if power loss is noticed, or annually, whichever occurs first.

1. Close inlet valve (or valve #1).
2. Remove T-handle and lid.
3. Remove filter by holding bail handles and slowly pulling upward with a twisting motion. Dispose of properly.
4. Replace old lid gasket and T-handle O-ring with new seals (supplied with new filter). Lubricate both seals with clean motor oil or diesel fuel before installation.
5. Refer to Priming Instructions otherwise, fill filter with clean fuel, then replace lid and T-handle and tighten snugly by hand only—do not use tools.

Trouble Shooting

- Air bubbles appearing from turbine are an indication of an upstream leak between filter inlet and fuel tank pick-up tube or excessive restriction in the fuel system.
- Engine won't start, verify the valve is in the open position for fuel flow.

Replacement Parts

See cut sheet RSL0410 Turbine FV Series for available parts and optional accessories.

Online Link
Turbine Replacement
Element Product
Selector



All products manufactured or distributed by Racor are subject to the following, and only the following, LIMITED EXPRESS WARRANTIES, and no others: For a period of one (1) year from and after the date of purchase of a new Racor product, Racor warrants and guarantees only to the original purchaser-user that such a product shall be free from defects of materials and workmanship in the manufacturing process. The warranty period for pumps and motors is specifically limited to ninety (90) days from date of purchase. A product claimed to be defective must be returned to the place of purchase. Racor, at its sole option, shall replace the defective product with a comparable new product or repair the defective product. This express warranty shall be inapplicable to any product not properly installed and properly used by the purchaser-user or to any product damaged or impaired by external forces.

THIS IS THE EXTENT OF WARRANTIES AVAILABLE ON THIS PRODUCT. RACOR SHALL HAVE NO LIABILITY WHATSOEVER FOR CONSEQUENTIAL DAMAGES FLOWING FROM THE USE OF ANY DEFECTIVE PRODUCT OR BY REASON OF THE FAILURE OF ANY PRODUCT. RACOR SPECIFICALLY DISCLAIMS ALL OTHER WARRANTIES, EXPRESS OR IMPLIED INCLUDING, WITHOUT LIMITATION, ALL WARRANTIES OF FITNESS FOR A PARTICULAR PURPOSE (EXCEPT FOR THOSE WHICH APPLY TO PRODUCT OR PART THEREOF THAT IS USED OR BOUGHT FOR USE PRIMARILY FOR PERSONAL, FAMILY, OR HOUSEHOLD PURPOSES), WARRANTIES OF DESCRIPTION, WARRANTIES OF MERCHANTABILITY, TRADE USAGE OR WARRANTIES OR TRADE USAGE.

Warning! Failure or improper selection or improper use of the products and/or systems described herein or related items can cause death, personal injury and property damage. This document and other information from Parker Hannifin Corporation, its subsidiaries and authorized distributors provide product and/or system options for further investigation by users having technical expertise. It is important that you analyze all aspects of your application and review the information concerning the product or system in the current product catalog. Due to the variety of operating conditions and applications for these products or systems, the user, through its own analysis and testing, is solely responsible for making the final selection of the products and systems and assuring that all performance, safety and warning requirements of the applications are met. The products described herein, including with limitation, product features, specifications, designs, availability and pricing, are subject to change by Parker Hannifin Corporation and its subsidiaries at any time without notice.

The following statement is required pursuant to proposition 65, applicable in the State of California:  WARNING: The products described in this literature can expose you to chemicals including Diisononyl phthalate, Carbon black extract, which are known to the State of California to cause cancer. For more information go to www.P65Warnings.ca.gov.

Questions? Email: racortech@parker.com Phone: 800-344-3286 News: www.racornews.com

