



## Microfilter for Technical Gases



<b>TGA 102-118</b>	<b>16-50 Bar</b>
<b>TGH 104-118</b>	<b>100-420 Bar</b>
<b>TGS 214-232</b>	<b>16-100 Bar</b>
<b>TGE302-326</b>	<b>16-100 Bar</b>



EN | Operating Instructions

14/02/2022 Rev. 05  
cod: 398H271902



## Index

<b>1. General information</b>	<b>2</b>
Warranty notes .....	2
Notes on these operating instructions .....	2
<b>2. For your own safety</b>	<b>4</b>
Intended use .....	4
Hazard areas on the filter .....	5
Safety notes on specific operating phases .....	5
<b>3. Assembly Drawings</b>	<b>7</b>
<b>4. Storing filters and filter elements</b>	<b>11</b>
Storing filter elements and cartridges .....	11
<b>5. Filter installation</b>	<b>12</b>
Requirements and preparatory activities.....	12
Installation .....	12
<b>6. Maintenance intervals and work</b>	<b>14</b>
Maintenance tasks .....	15
<b>7. Correcting faults</b>	<b>21</b>
Procedure following a pressure blow .....	21
Insufficient filtration capacity.....	21
<b>8. Technical information</b>	<b>22</b>
Filter types.....	22
Specification of elements.....	26
<b>9. Spare parts and options</b>	<b>27</b>
Spare part ordering .....	27
Available options .....	27

# 1. General information

## Warranty notes

In the following cases, the warranty shall be void:

- ◇ If corrosion and malfunctions occur due to aggressive substances in the gas and in the environment.
- ◇ If the filter is not used in accordance with its intended use.
- ◇ If the filter is not serviced as specified in these operating instructions.
- ◇ If spare parts not matching the quality of genuine parts are used.
- ◇ If the filter is operated with other media than those indicated on the type label.
- ◇ If modifications not approved by the manufacturer are made to the filter.
- ◇ When an ATEX-compliant filter was not properly integrated in the local equipotential bonding system.

## Notes on these operating instructions

The present operating instructions contain important information on the safe and economic operation of filter series TGA1, TGH1, TGS2 and TGE3 for technical gases.

### Layout conventions

- ▶ Work steps that you have to carry out one after the other are numbered.
- ◇ Lists are marked by a small box.



**This symbol accompanies information relevant to explosion protection as per ATEX (94/9/EEC).**



### Warning!

**These safety notes warn against damage to machines or equipment and help you to avoid such damage.**



### Danger!

**These danger notes with a grey background warn against personal injury and/or danger to life and limb; danger notes help you to avoid dangerous or life-threatening situations for yourself and/or third parties.**

### Target group of these operating instructions

The present operating instructions address all persons who work with and on the filter. We assume that these persons are specialized staff, e.g. fitters or electricians or appropriately instructed staff.

We assume the following:

- ◇ There are appropriate operating instructions for the application intended by the operator.
- ◇ The staff has been instructed how to handle the used gas and is aware of the involved risks and the general danger prevention measures.
- ◇ The staff have basic experience in handling pneumatic devices.

**Notes on handling operating instructions**

These operating instructions must be continuously available at the site where the filter is used. We recommend to prepare a copy and to keep the same in a safe and freely accessible place next to the filter. Keep the original document in a safe place.

## 2. For your own safety

**Note:**

**When carrying out any work on the filters comply with all applicable national accident prevention regulations!**

### Intended use

A filter of the series described here must be exclusively used for filtering the gas noted on the filter's type label. The technical data specified on the type plate must be observed and complied with. Any operation at conditions other than those indicated on the type label is regarded as not intended. Please contact the manufacturer if you plan to use the filter for gases other than those indicated on the type label.



ATEX-compliant filters as per CE Ex II 2G marking must be operated in zone 1 and zone 2 only.

ATEX-compliant filters are conductive. The operator must make sure conductivity is maintained under all circumstances. He must also make sure that the conductivity is not impaired by any attachment parts. The conductivity must be tested and approved after each service assignment.

To ensure proper preliminary filtration, a strainer filter must be installed upstream of any C, CF or CSF filter element. Operation of C, CF or CSF filter elements is regarded as not intended if these conditions are not met.

### Obvious improper use



**Danger when explosive gases are filtered!**

Filters not marked with an ATEX code on the type label must not be used to filter explosive gases or for operation in an explosive environment.







**Hazard caused by hot surfaces!**

**The media that flow through the filter can have a temperature of up to 80 °C. Do not touch hot surfaces. Note the operating instructions issued by the operator.**

### Impermissible maloperation

- ◇ filtering instable gases (e.g. acetylene).
- ◇ filtering liquids
- ◇ conveying solid, dustlike goods.

## Hazard areas on the filter

Symbol	Hazard area
	<p><b>Warning against overpressure</b> The entire filter is pressurised during operation. Relieve all pressure before starting any work on the filter.</p>
	<p><b>Warning against explosive atmosphere/explosive gas</b> Only filters with the appropriate ATEX code must be used in a potentially explosive environment and for filtering explosive gases. The filters must be connected to the customer's equipotential bonding system (local equipotential bonding).</p>
	<p><b>Beware of critical gases</b> The filtered gas could be hazardous. Keep appropriate notes on hazardous substances at hand and heed them when working with critical gases.</p>
	<p><b>Beware of hot surfaces</b> The filtered gas can be very hot and thus heat up the filter's surfaces. Do not touch hot surfaces. Wait until the surfaces have cooled down before starting work on the filter</p>

## Safety notes on specific operating phases

### Notes on critical gases

All explosive, flammable and poisonous gases of fluid groups 1+2 as per pressure equipment directive 2014/68/EU are referred to as critical gases.

- ◇ The release of a critical gas can pose a considerable risk to man and environment and must therefore be prevented by all means:
  - The operator must implement appropriate safety precautions.
  - Flush the respective pipe section and the filter with an inert gas prior to all work that could result in critical gas being released. Then depressurise the filter and carry out the work.

 – .. Verify the absence of an explosive atmosphere (in line with the operator's Directives); if necessary, cancel the EX zone first. Start work only after applying these measures.

- ◇ Make sure to heed the notes on hazardous substances for the used gas when filtering a critical gas!

### Notes on transportation and installation

- ◇ The transportation — in particular of larger build type filters — may be carried out by specialist personnel only.
- ◇ Filters damaged during transportation must not be installed.
- ◇ Store filters, filter elements and cartridges in the unopened original packing in a clean, dry place until they are used.

### Notes on filter operation

- ◇ Do not perform any unapproved conversions and modifications on the filters. Non-approved modifications will endanger the operational safety and may cause damage or personal injury.

For ATEX-compliant filters:

- Filters for explosive gases as per ATEX must be earthed. Establish an appropriate local equipotential bonding. Test and document the conductivity.



- For installation under explosion group IIC:

Make sure when attaching decals or other markings that the area they cover does not exceed a total contiguous area of 20 cm<sup>2</sup>!

- Make sure when painting that the permissible coat thickness does not exceed the limits stipulated for the area of application.

- The control of electronic accessories for ATEX-compliant filters must be intrinsically safe.

- ◇ Avoid sudden pressure fluctuations on pressure build-up and de-pressurization. If the pressure builds up or drops, too quickly, this may cause damage to the filter.
- ◇ When using accessories with an external power supply, there is a hazard from electrical voltage. Heed the notes given in the operating instructions for the accessories. Work on electrical components only when they are deenergised.

### Notes on maintenance

- ◇ Always maintain the prescribed service intervals. If these are not complied with, the filter may not function correctly and the manufacturer does not accept any liability whatever for any possible consequences.
- ◇ Repairs and maintenance should be carried out by specialist personnel only.



Use only suitable tools when working in an explosive environment.

### Notes on disassembly and disposal

- ◇ Flush the entire system, including the filter, with inert gas before disassembling filters used for filtering critical gases. Depressurise and disassemble the filter only then.
- ◇ The filter housing and elements might be contaminated by substances held back in the filter. Filters used for the filtering of critical gases might contain explosive, flammable or poisonous substances. Therefore always read the material safety data sheet of the respective gas. Dispose of all components of the filter according to the applicable statutory regulations.

### 3. Assembly Drawings

TGA 102–118, 16 bar and 25–50 bar

Item	Description
1	Locking screw
2	Upper housing
3	Filter element O-ring
4	Housing O-ring
5	Threaded rod
6	Filter element
7	Lower housing
8	16 bar Manual drain HV01-TG
-	25, 50 bar: Manual drain EV05-TG
-	16 bar ATEX: Manual drain EV05-TG
Optional	
A	Differential pressure gauge HZD80/50RTGS with adapter block
B	Earthing lug (for ATEX-compliant filters)
-	Condensate drain 11LD (16–25 bar)

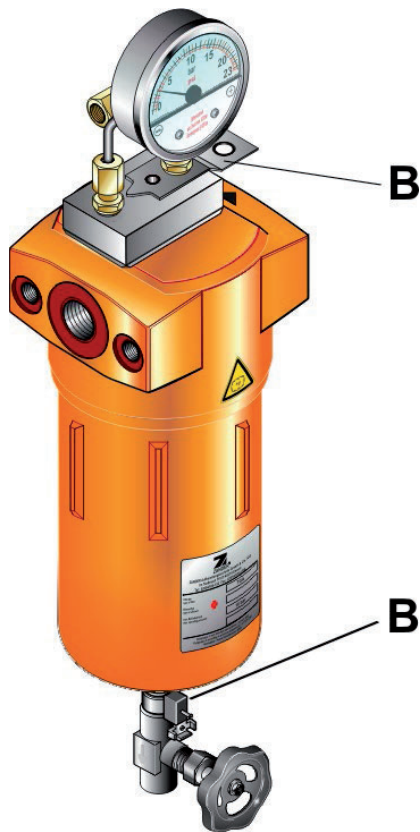
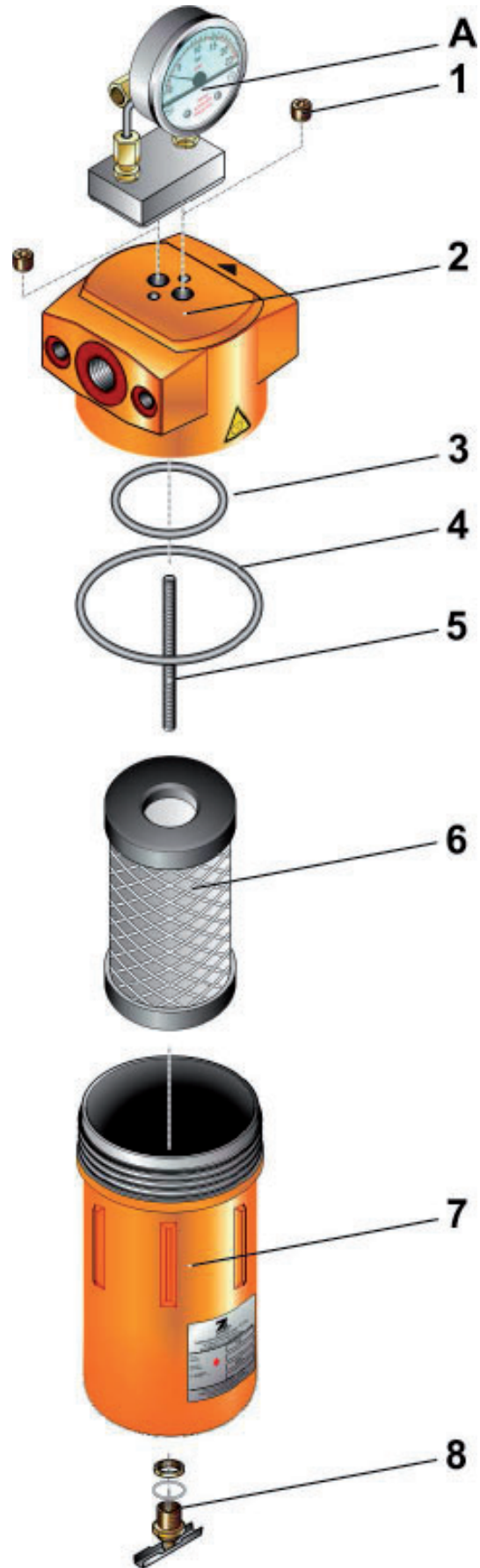

TGH 104-118, 100–420 bar

Item	Description
1	Locking screw
2	O-ring
3	Upper housing
4	Threaded rod
5	Filter element O-ring
6	Filter element
7	Housing O-ring
8	Lower housing
9	Double nipple
10	Manual drain EV05-TG

Optional

A	Differential pressure gauge HZD80/50RTGS
B	Earthing lug (only for AT- EX-compliant filters)

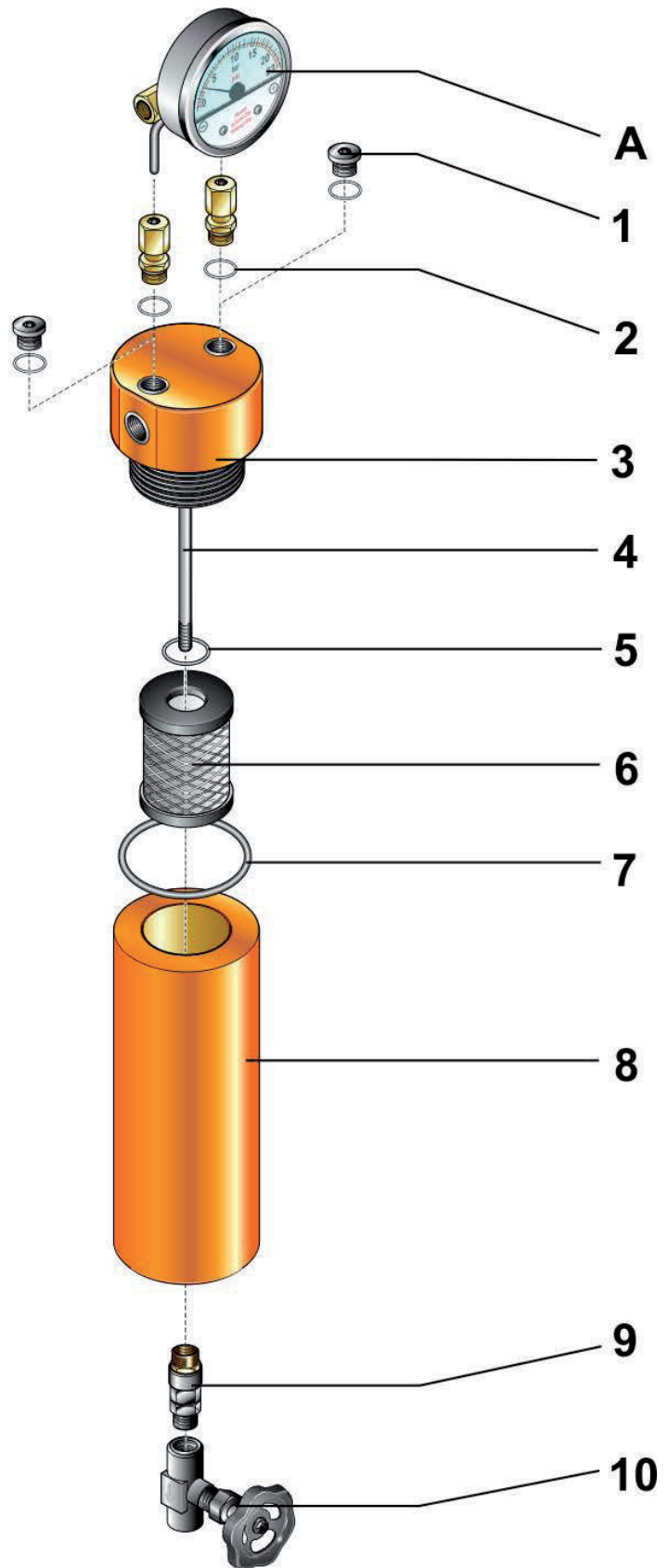
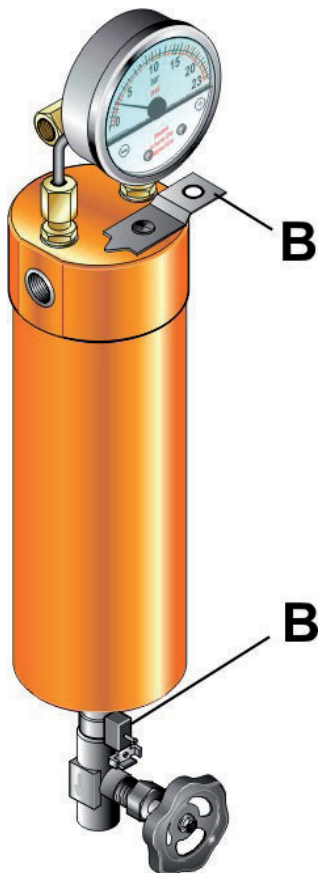

TGS 214-232, 16 bar

Item	Description
1	Upper housing
2	Flat seal, housing
3	Filter element
4	Manual drain EV05-TG through EV08-TG
5	Lower housing

Optional

A	Differential pressure gauge HZD80/50RTGS with connection pipes
B	Earthing lug and connection bore (only for ATEX-compliant filters)
—	Condensate drain 11LD (up to TGS 218, 16–25 bar)

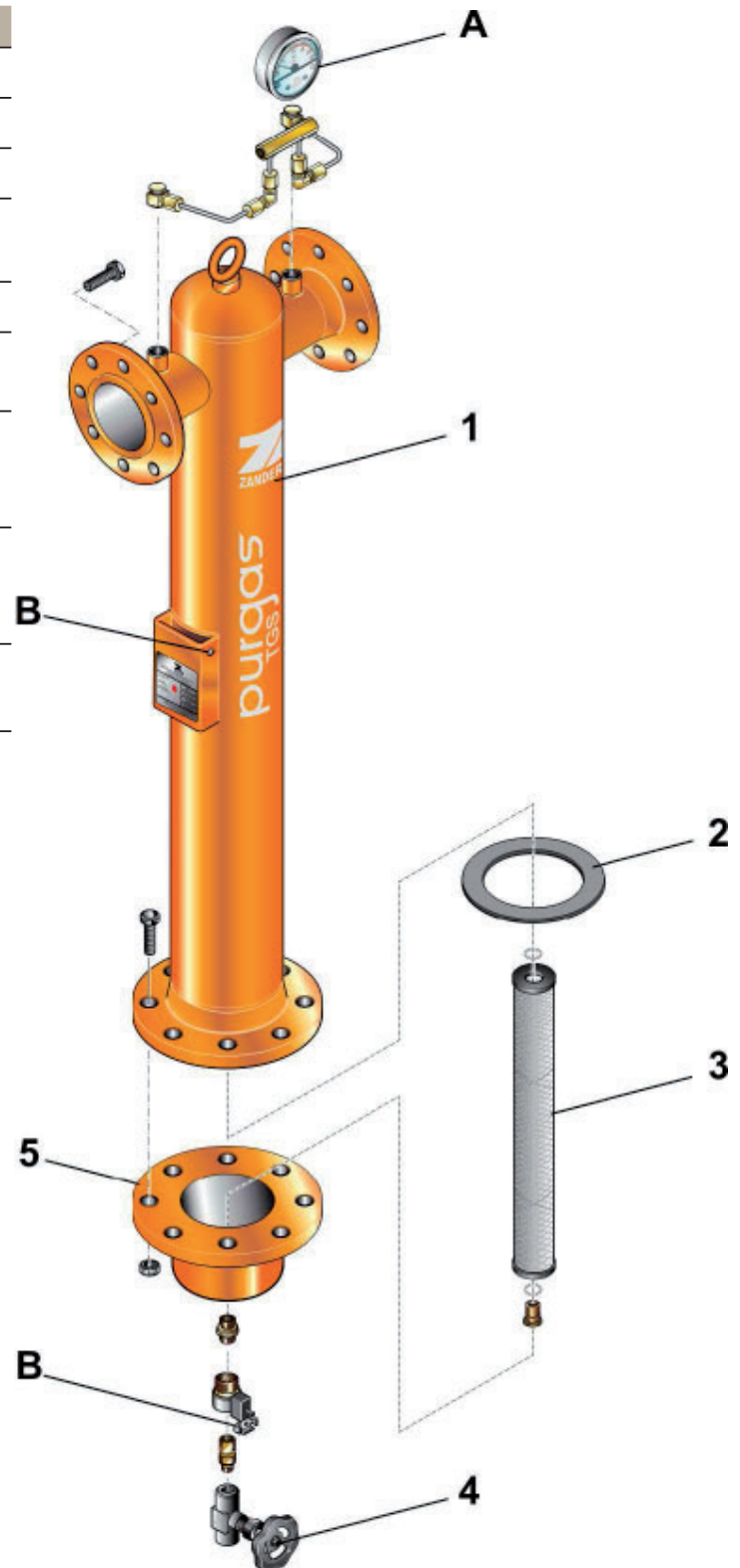

TGE 302-326, 16–100 bar

Item	Description
1	Locking screw
2	Upper housing
3	Filter element
4	Housing O-ring
5	Lower housing
6	Lock ring
7	Double nipple
8	Manual drain EV05-TG

Optional

A	Differential pressure gauge HZD80/50RTGS with connection pipes
B	Earthing lug (only for AT-EX-compliant filters)
—	Condensate drain 11LD (16–25 bar)

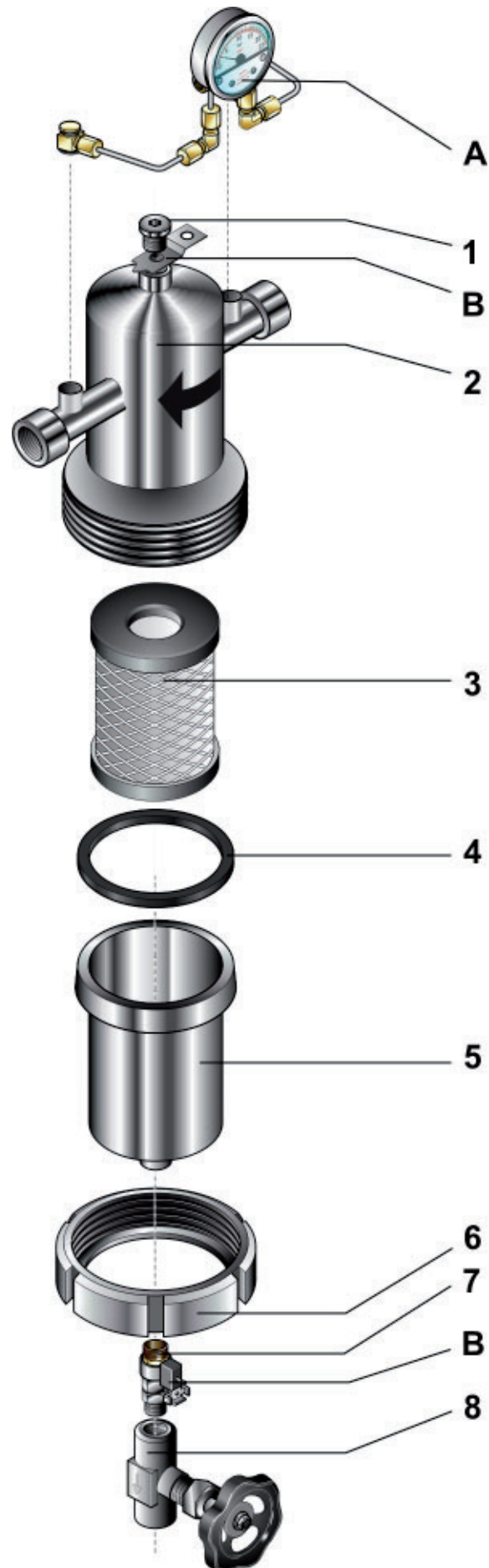
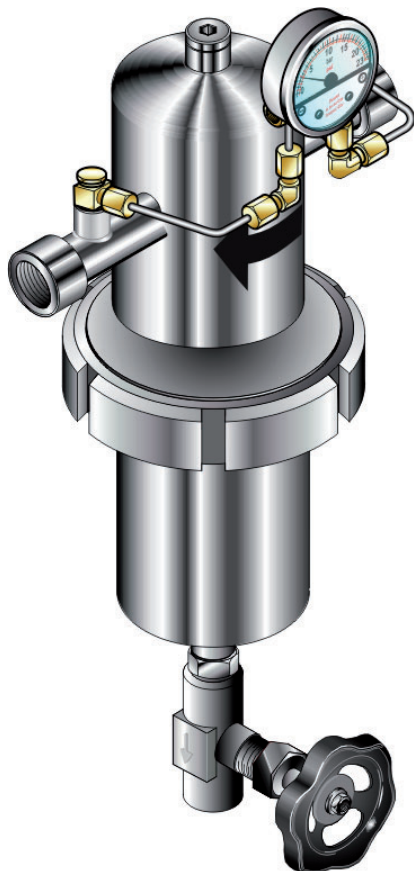

## 4. Storing filters and filter elements

The storage space must meet the following conditions when the filter is to be stored for a longer period:

- ◇ The filter must not be stored out of doors.
- ◇ The storage space must be dry.
- ◇ The storage space must be free of dust, or the filter must be packed dustproof.
- ◇ The storage space must feature an ambient temperature of at least +1 °C.

**Caution:**



**When you want to store the filter for a longer period (e.g. several months), you must check the threads for well running from time to time to prevent corrosion**

### Storing filter elements and cartridges

- ▶ Store filters and cartridges in the unopened original packing until they are used. For storage space requirements, see the previous section.

## 5. Filter installation

The filters are supplied in a ready to operate condition and can be installed directly into the pipe system. To prevent transport damage, any ordered options come separately packed. These accessories must be fitted to the filter before commissioning and in accordance with the respective instructions supplied.



Also heed the information provided in the ancillary documents coming with the accessories when installing ATEX-compliant accessories!  
The control of electronic accessories for ATEX-compliant filters must be intrinsically safe.

### Requirements and preparatory activities

- ◇ As a rule, the filters should always be used in the pipe system at the point with the lowest temperature.
- ◇ Ensure that the pipeline system is free of any contamination and clean it before installing the filter, if necessary.
- ◇ To ensure larger particles are safely trapped, a suitable strainer filter must be installed upstream of any C, CF or CSF filter element.
- ◇ A safety device for maintaining the maximum working pressure and the permissible gas temperature must be available. This safety device must prevent that limit values are exceeded.
- ◇ A suitable pressure relief device and a condensate drain must be installed for the filter. This safety device must prevent critical gas from escaping into the atmosphere.

#### **Danger due to release of a critical gas!**

**The release of a critical (explosive, flammable, poisonous) gas from the network can constitute a considerable risk for man and environment.**



**Therefore heed the following before working on filters for critical gases**

- flush the pipe section in question with inert gas
- have the notes on hazardous substances for the used gas ready
- take appropriate protection measures



- verify the absence of an explosive atmosphere

### Installation

- ▶ Before installing the filter:
  - flush the pipe section in question with inert gas if necessary
  - and depressurise the system.
- ▶ Check filter for possible transport damage. Do not fit a damaged filter.
- ▶ If necessary, fit a bracket or pipe support. Construct the support device such that it can bear the weight of a filter completely filled with liquid.
- ▶ Heed the flow direction when installing the filter in the pipeline! The gas must flow through the filter in the direction of the arrow on the upper housing only.

- ▶ The filter must always be fitted vertically.
- ▶ Ensure that there is sufficient space below the filter so it can be easily disassembled (see dimension D in the Technical Data).



- ▶ For ATEX-compliant filters:
  - Filters for explosive gases as per ATEX must be earthed. For this purpose, the filters are fitted with earthing lugs ex factory (see also the overview drawings). Establish an appropriate local equipotential bonding. Test and document the conductivity.
  - Make sure when attaching decals or other markings that the area they cover does not exceed a total contiguous area of 20 cm<sup>2</sup>!
  - Make sure when painting that the permissible coat thickness does not exceed the limits stipulated for the area of application.

- ▶ When installing differential pressure gauge HZDE80/...:  
Establish electrical connection.
- ▶ Re-pressurize pipe section and check for leaks.

#### When installing a filter with TKM or TKA cartridge



**Beware of damage due to wrong flow direction!**

**Heed the flow direction when installing the filter in the pipeline!**

**The gas must flow through the filter in the direction of the arrow on the upper housing only. The intended flow direction for a cartridge is from bottom to top.**

**A reversed air flow through the cartridge can damage the cartridge.**

- ▶ Also heed the general information on filter installation in the previous “Installation” section.
- ▶ Install a filter with cartridge so that the gas flow is from bottom to top. Wear debris can exit from the cartridge, contaminate the downstream gas network or degrade the gas quality.
- ▶ Prevent any contamination of the downstream gas network by installing a suitable particle filter.

## 6. Maintenance intervals and work



**Hazard due to a sudden release of pressure!**

Never remove any parts of the filter, or manipulate the same in any way, for as long as the filter is still pressurised! A sudden escape of pressure may cause serious injuries.

Depressurise the filter before carrying out any work on the filter.

**Danger due to release of a critical gas!**

The release of a critical (explosive, flammable, poisonous) gas from the network can constitute a considerable risk for man and environment.



Therefore heed the following before working on filters for critical gases

- flush the pipe section in question with inert gas
- have the notes on hazardous substances for the used gas ready
- take appropriate protection measures



- verify the absence of an explosive atmosphere

### Maintenance intervals

Component/series	Action	Maintenance interval				
		1	2	3	4	5
Manual drain valve	Drain condensate	x				
Entire filter	Clean		x			
Earthing lugs	Retighten			x		
TGA1, TGH1, TGE series: Housing	Check well running of threads			x		
C, CF, CSF, HTNX	Replace the filter element				x	
Housing	Replace O-ring or flat seal				x	
TGA1, TGH1 series: TKA, TKM, CS, OX, SG cartridge	Renew cartridge					

1 = Daily

2 = Weekly

3 = Every 6 months

4 = Every year (regardless of operating hours), at the latest with a differential pressure of 0.35 bar (0.6–0.8 bar for a high pressure filter)

5 = Depending on the load or to be determined by measuring

## Maintenance tasks

### Preparations

Make the following preparations before performing maintenance on filters.

- ▶ When critical gases are fed:  
Flush the pipe section in question and the filter with inert gas.



- ▶ Verify the absence of an explosive atmosphere (in line with the operator's Directives); if necessary, cancel the EX zone first. Start work only then.

- ▶ All gases:
  - Block gas supply to the filter.
  - Depressurise the filter housing. Make sure the pressure has been positively relieved.
  - Allow filter to cool down

Start work only when these condition are met.

### Drain condensate

Draining may be necessary several times a day, depending on the amount of condensate produced.

- ▶ Take appropriate measures to prevent the gas from escaping into the atmosphere.
- ▶ Drain the collected condensate at regular intervals and properly dispose of it.

### Clean filter

#### ATEX-compliant filters

Dust that has collected on the filter can pose a potential risk. It is therefore vital to regularly clean the filter. The cleaning interval depends on the dust concentration in the ambient air. The higher the dust concentration, the more frequently must the filter be cleaned.

#### Beware of static charges!



**Never use dry cloths to clean ATEX-compliant filters! A static charge could build up due to the friction. This could represent an ignition source.**

**Therefore: Make sure to clean the filter with a moist cloth only!**

- ▶ Clean the filter with a moist cloth at regular intervals to prevent the formation of hazardous dust agglomerations.
- ▶ Moisten the cloth with water only, wring out thoroughly, do not use any detergents!

### Filters not intended for an ATEX environment

- ▶ Clean the filter with a moist cloth once a week.
- ▶ Moisten the cloth with water only, wring out thoroughly, do not use any detergents!

## Retighten the earthing lugs on ATEX-compliant filters



The earthing lugs on ATEX-compliant filters can loosen over the time. The conductivity may then be impaired.

- ▶ Tighten the earthing lugs every 6 months.

## Replacing filter element and housing O-ring

Replace the filter element every year, but at the latest with a differential pressure of 0.35 bar (0.6–0.8 bar for a high pressure filter). Also replace the housing O-ring.

**Beware of damage due to inexperienced handling!**

**Never use unsuitable tools to open and close the filter housings. Never apply the tool to the thread area. The exerted force could crush the thread; it would then be impossible to open the filter again.**



**Use a suitable open-ended spanner to open and close the filter if possible. Apply the open-ended spanner to the square at the housing bottom. Use a similarly suitable tool, e.g. a strap wrench if an open-ended spanner cannot be used. Apply the tool clearly below the thread.**

## TGA and TGH filters

- ▶ Make the same preparations as described in section on page 15.
- ▶ Unscrew the lower housing and remove it.
- ▶ Unscrew the filter element with the O-ring and discard it.
- ▶ Discard the housing O-ring.
- ▶ Insert a new filter element with O-ring and hand-tighten the filter element.
- ▶ Insert a new housing O-ring.
- ▶ Apply a thin coat of grease on the housing threads before assembly if necessary. Use only TG 1 thread grease unless any other grease has been agreed upon in the order!
- ▶ Make sure during assembly that
  - the O-rings are properly seated
  - the grease does not come into contact with O-rings and sealing surfaces.
- ▶ Both housing parts have marking arrows.
- ▶ Connect both housing parts again and hand-tighten them until the marking arrows match.
- ▶ Close the manual drain valve again.



- ▶ For ATEX-compliant filters: Ensure conductivity, test and document it.

- ▶ Check the housing for tightness.

### TTGS filters

Depending on its size, a filter housing can accommodate up to 10 filter elements. The following description applies to a single filter element per housing, but equally to several ones as well.

- ▶ Make the same preparations as described in section on page 15.
- ▶ Unscrew and remove the nuts on the lower housing.
- ▶ Remove the lower housing or swing it aside.
- ▶ Remove flat seal.
- ▶ Unscrew and remove the filter element.
- ▶ Insert a new filter element with O-ring and hand-tighten the filter element.
- ▶ Insert new flat seal.
- ▶ Make sure the O-ring and the flat seal are properly seated.
- ▶ Assemble upper and lower housing and tighten the screws again.
- ▶ Close the manual drain valve again.



- ▶ For ATEX-compliant filters:  
Ensure conductivity, test and document it.

- ▶ Check the housing for tightness.

**TGE filters**

- ▶ Make the same preparations as described in section on page 15.
- ▶ Open the lock ring with a hook wrench and take the lower housing out of the cap.
- ▶ Turn the filter element so that it is in release position, using the click-lock device, and remove the filter element.
- ▶ Remove the housing O-ring and replace it with a new one.
- ▶ Insert new filter element and lock it in place.
- ▶ Apply a thin coat of grease on the housing threads before assembly if necessary. Use only TG 1fn thread grease unless any other grease has been agreed upon in the order!
- ▶ Make sure during assembly that
  - the O-rings are properly seated
  - the grease does not come into contact with O-rings and sealing surfaces.
- ▶ Insert the lower housing into the cap again and fasten it with the lock ring.



- ▶ For ATEX-compliant filters:  
Ensure conductivity, test and document it.

- ▶ Check the housing for tightness.

---

## Replacing the cartridge of TGA and TGH filters

**Note on intervals:**

The operating conditions of cartridges with their respective fillings are very specific and differ with regard to application. It is therefore impossible to recommend any fixed intervals.

It is safest to determine the necessary exchange by measuring.

Please contact an authorised laboratory or the manufacturer for this purpose.

Unscrew the lower housing and remove it.

- ▶ Make the same preparations as described in section “Preparations” on page 15.
- ▶ Unscrew the cartridge with the O-ring and discard it.
- ▶ Discard the housing O-ring.
- ▶ Insert a new cartridge with O-ring and hand-tighten the cartridge.
- ▶ Make sure the gas flows through the cartridge in the right direction (also see the note on page 13).
- ▶ Insert a new housing O-ring.
- ▶ Apply a thin coat of grease on the housing threads before assembly if necessary. Use only TG 1 thread grease unless any other grease has been agreed upon in the order!
- ▶ Make sure during assembly that
  - the O-rings are properly seated
  - the grease does not come into contact with O-rings and sealing surfaces.

Both housing parts have marking arrows.

- ▶ Connect both housing parts again and hand-tighten them until the marking arrows match.
- ▶ Close the manual drain valve again.



- ▶ For ATEX-compliant filters:  
Ensure conductivity, test and document it.

Check the housing for tightness.

### Check well running of threads

There is a risk of threads seizing when a filter made of aluminium, steel or stainless steel is stored.

- ▶ Make the same preparations as described in section “Preparations” on page 15.
- ▶ Open the filter at regular intervals, e.g. every 6 months.
- ▶ Check whether the threads are still sufficiently greased and well running.
- ▶ Apply a thin coat of grease on the housing threads before assembly if necessary. Use only TG 1 thread grease unless any other grease has been agreed upon in the order!
- ▶ Connect both housing parts again.



- ▶ For ATEX-compliant filters:  
Ensure conductivity, test and document it.

- 
- ▶ Check the housing for tightness.

### **Disposing of filter elements and cartridges**

The filter element or cartridge might be contaminated by the filtered substances. Heed the notes on hazardous substances for the filtered gas and applicable disposal regulations when disposing.

You can obtain the waste code number for the used materials from the manufacturer.

## 7. Correcting faults

### Procedure following a pressure blow

Pressure blows can occur, e.g. when valves are opened suddenly. The filter element may still be usable following a pressure blow. But you must first check it for damage. A damaged filter element must be replaced.

- ▶ When critical gases are fed:  
Flush the pipe section in question and the filter with inert gas.



- ▶ Verify the absence of an explosive atmosphere (in line with the operator's Directives); if necessary, cancel the EX zone first. Start work only then.

- ▶ All gases:
  - Block gas supply to the filter.
  - Depressurise the filter housing. Make sure the pressure has been positively relieved.
  - Allow filter to cool down.
  - Remove the element and check it for damage (e.g. cracks or the like).
- ▶ Replace any damaged element (see page 12).

Please contact the manufacturer if pressure blows occur more frequently.

### Insufficient filtration capacity

If the filtration capacity is insufficient, although the filter element was replaced at the correct intervals, then the ambient conditions of use or throughput rates may not have been matched to the filter used. Contact the manufacturer.

## 8. Technical information



### Note:

The temperature class as per ATEX depends on the temperature of the infed gas. The TG filters are generally suited for any temperature class because they do not feature a thermal source.

### Filter types

TGA 102–118, 16–50 bar

Type	Capacity*	Connection	Dimensions (mm)				Weight (Kg)			Element Num. x type
			A	B	C	D	PN 16	PN 25	PN 50	
	m <sup>3</sup> /h	G/DN								
TGA 102	depending on the medium, upon request	G 1/4	60	200	14	60	0,6	0,8	0,8	TA 30_
TGA 104		G 1/4	87	201	21	75	1,0	0,8	0,8	TA 50_
TGA 106		G 3/8	87	201	21	90	1,0	1,2	1,2	TA 70_
TGA 108		G 1/2	87	271	21	160	1,2	1,2	1,2	TA 90_
TGA 110		G 3/4	130	306	43	135	3,8	1,4	1,4	TB 10_
TGA 112		G 1	130	406	43	235	4,5	4,1	4,1	TB 20_
TGA 114		G 1 1/2	130	506	43	335	5,0	4,9	4,9	TB 30_
TGA 116		G 1 1/2	130	706	43	525	6,4	5,0	5,0	TB 50_
TGA 118		G 2	164	751	48	520	9,6	6,6	6,6	TC 50_

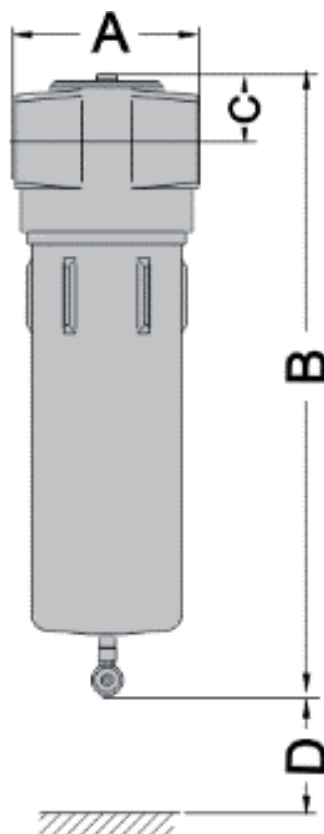

TGH 104–118, 100–350 bar\*

Type	Capacity*	Connection	Dimensions (mm)				Weight (Kg)			Element
	m <sup>3</sup> /h		A	B	C	D	PN 100	PN 250	PN 350	Num. x type
<b>TGH 104</b>	depending on the medium, upon request	G 1/4	85	330	25	100	3,3	3,3	3,3	TA 50_
<b>TGH 106</b>		G 3/8	85	330	25	115	3,4	3,4	3,4	TA 70_
<b>TGH 108</b>		G 1/2	85	395	25	185	3,9	3,9	3,9	TA 90_
<b>TGH 110</b>		G 3/4	116	445	25	170	11,0	14,0	19,0	TB 10_
<b>TGH 112</b>		G 1	116	530	25	270	12,4	17,4	21,6	TB 20_
<b>TGH 114</b>		G 1 1/4	125	640	33	335	16,5	21,5	28,0	TB 30_
<b>TGH 116</b>		G 1 1/2	125	900	33	560	21,0	30,0	40,0	TB 50_
<b>TGH 118</b>		G 2	155	925	45	565	31,0	47,0	62,0	TC 50_

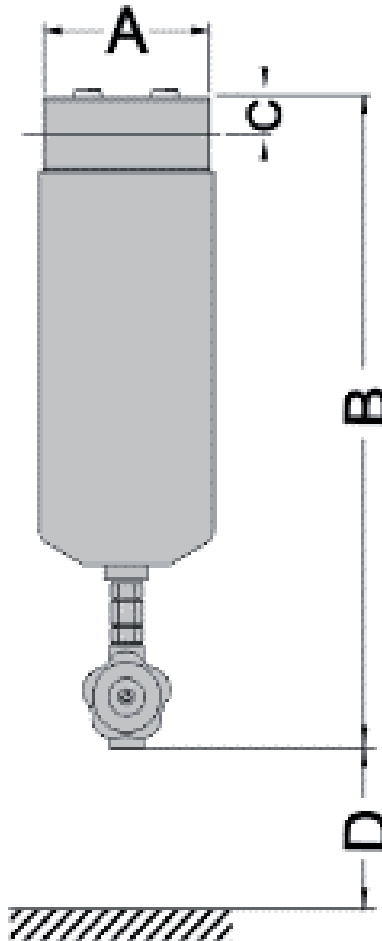

\*Technical data for filters 450 bar on request

TGS 214–232, 16–100 bar

Type	Capacity*	Connection	Dimensions (mm)				Weight	Element
	m <sup>3</sup> /h		A	B	C	D		
TGS 214	depending on the medium, upon request	DN 50	380	931	167	315	31,0	1/TC 50_
TGS 216		DN 65	380	1180	175	530	38,0	1/TC 75_
TGS 218		DN 80	420	1180	175	530	42,0	1/TD 60_
TGS 220		DN 80	440	1320	205	530	44,0	1/TD 75_
TGS 222		DN 100	500	1440	230	550	101,0	2/TC 75_
TGS 224		DN 100	500	1440	230	550	102,0	3/TC 75_
TGS 226		DN 150	640	1590	280	550	136,0	4/TC 75_
TGS 228		DN 150	790	1650	300	550	220,0	6/TC 75_
TGS 230		DN 200	790	1730	340	550	252,0	8/TC 75_
TGS 232		DN 200	840	1780	360	550	353,0	10/TC 75_

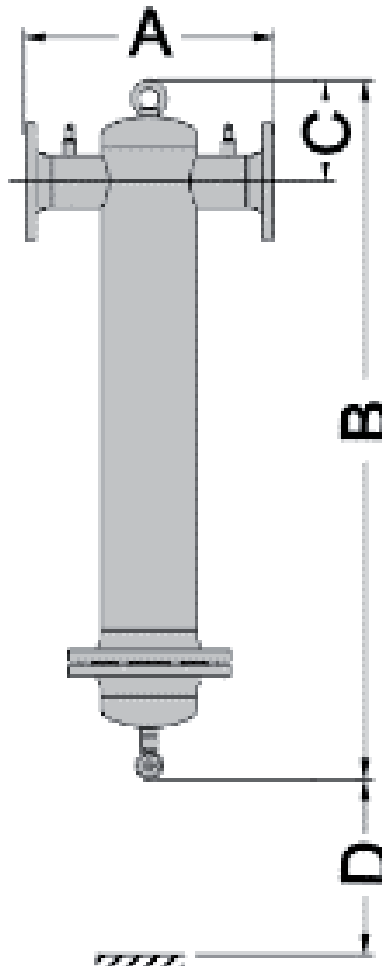

TGE 308–326, 16–100 bar

Type	Capacity*	Connection	Dimensions (mm)				Weight	Element
	m <sup>3</sup> /h		A	B	C	D		
<b>TGE 302</b>	depending on the medium, upon request	G 1/4	197	300	55	85	3,0	TE_09
<b>TGE 304</b>		G 3/8	197	300	55	85	3,0	TE_09
<b>TGE 306</b>		G 1/2	201	300	55	85	3,0	TE_09
<b>TGE 308</b>		G 3/4	201	300	55	85	3,0	TE_09
<b>TGE 310</b>		G 1	238	391	75	140	4,2	TE 13_
<b>TGE 312</b>		G 1 1/4	248	391	75	140	4,2	TE 13_
<b>TGE 314</b>		G 1 1/2	248	391	75	140	4,2	TE 13_
<b>TGE 316</b>		G 2	283	565	80	280	7,1	TE 14_
<b>TGE 318</b>		G2 1/4	283	875	80	280	14,5	TE 18_
<b>TGE 320</b>		G 2 1/2	325	875	110	530	14,5	TE 18_
<b>TGE 322</b>		G3	339	1135	110	780	21,0	TE 19_
<b>TGE 324</b>		DN 80	350	739	145	410	32,6	TEL 19_
<b>TGE 326</b>		DN 100	430	742	198	490	45,0	TEL 20_

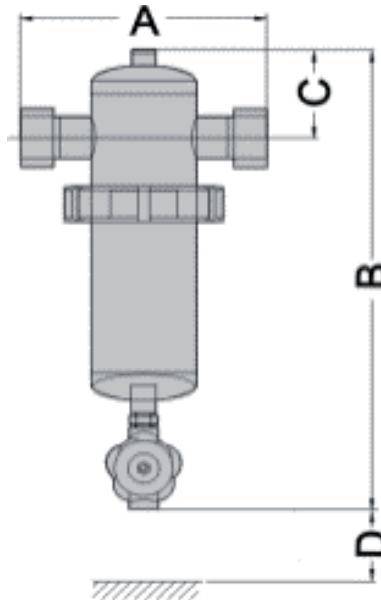

## Specification of elements

Degree of filtration	Element type	Filtration efficiency <sup>a)</sup>	Temp. (°C)
Strainer filter	S	95 % ( $\geq 1 \mu\text{m}$ )	1–120
Coarse filter	P	99,99 % ( $3 \mu\text{m}$ )	1 –60
	PL12	>99 % ( $12/25 \mu\text{m}$ )	1–120
	PL25		
	PL12-HTCR	>99 % ( $12/25 \mu\text{m}$ )	1–120
	PL25-HTCR		
EPL01	>99 % ( $1 \mu\text{m}$ )	1–120	
Fine filter	C	99,9999 % ( $1 \mu\text{m}$ ) $\leq 0,5 \text{ mg/m}^3$	1–80
Ultra-fine filter	CF	99,99999 % ( $0,01 \mu\text{m}$ ) $\leq 0,01 \text{ mg/m}^3$	1–80
Super-ultra-fine filter	CSF	$\geq 99,99999 \%$ ( $0,01 \mu\text{m}$ ) $\leq 0,001 \text{ mg/m}^3$	1–80
High temperature range HTNX <sup>b)</sup>	C/CF/CSF		1–120
High temperature range HTCR <sup>b)</sup>	C/CF/CSF		1–120
Cartridge <sup>c)</sup>	TKM	Molecular mesh filling	1–55
	TKA	Charcoal filling	1–40
	CS	Soda lime filling	1–40
	OX	Carulite filling	1–40
	SG	Silica gel filling	1–40
	Special	Special fillings	as per filling

<sup>a)</sup> for media with a mixture density of  $9.56 \text{ kg/m}^3$  , flow rate  $< 0.5 \text{ m/s}$ , mineral oil

<sup>b)</sup> available as C, CF and CSF elements. Filtration degree depends on the element type.

<sup>c)</sup> for TGA1 and TGH1 series only

## 9. Spare parts and options

### Spare part ordering

Please specify the correct order code (see the filter designation on the type label) when ordering spare parts

### Available options

- ◇ Differential pressure gauge HZD80/50RTG... and HZDE80/400RTG...\*
- ◇ Various manual drain valves
- ◇ Various wall mounts
- ◇ O-rings made of different materials (FPM, EPDM, NBR, VMQ, PTFE)

Other options and accessories upon request.



The control of electronic accessories for ATEX-compliant filters must be intrinsically safe.

\* with electronic switch contact.







A division of Parker Hannifin Corporation

---

## **Parker Hannifin Manufacturing S.r.l.**

Sede Legale:

Via Sebastiano Caboto 1, Palazzina "A" 20094 Corsico (MI) Italy

Sede Operativa:

**Gas Separation and Filtration Division EMEA** - Strada Zona Industriale, 4  
35020 S. Angelo di Piove (PD) Italy

tel +39 049 971 2111- fax +39 049 9701911

Web-site: [www.parker.com](http://www.parker.com)