

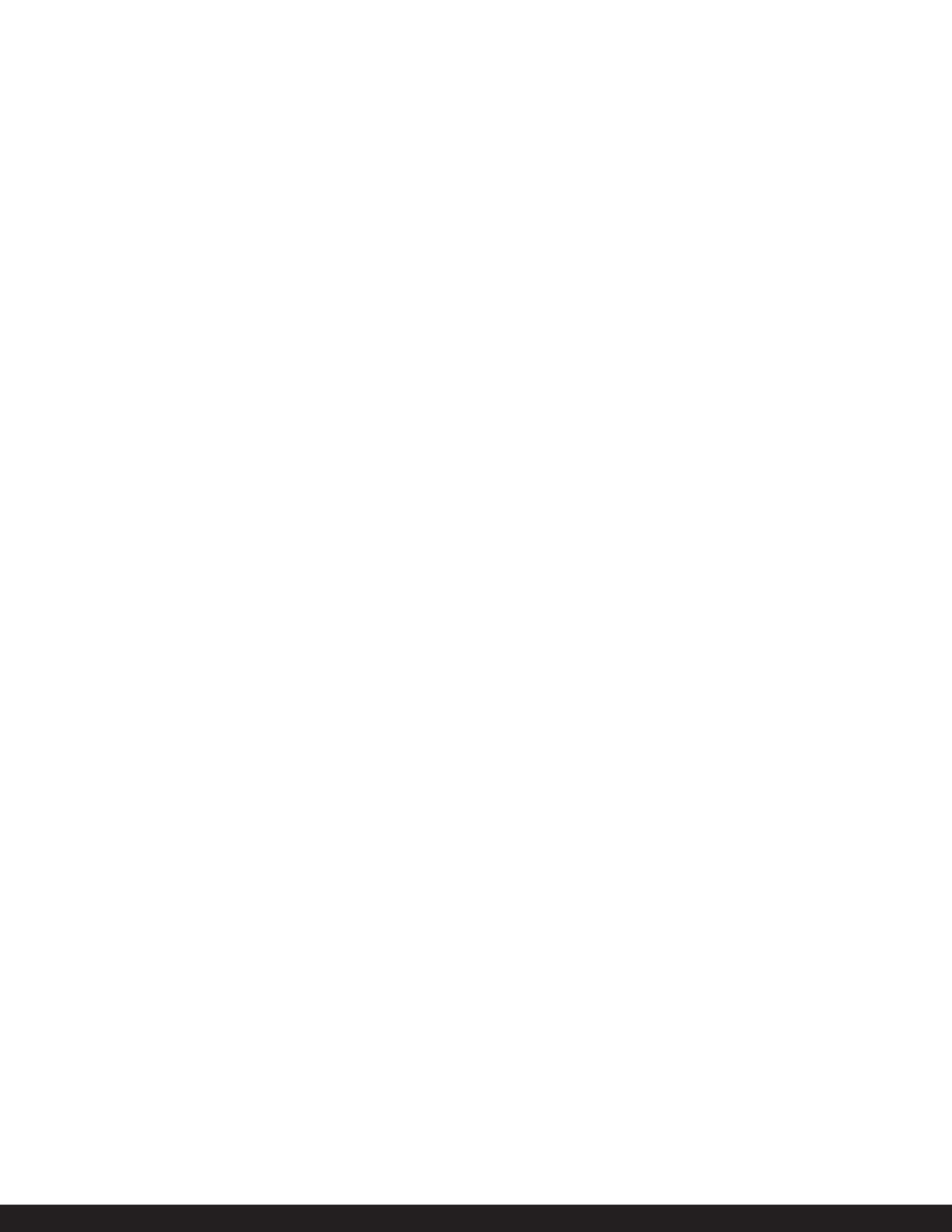

Parker Balston[®] Vacuum Pump Inlet and Exhaust Filters

Models AR-009-371H, AR-015-371H, R-009-30, R-015-30

Installation, Operation, and Maintenance Manual



Parker Balston AR-009-371H and AR-015-371H Vacuum Pump Exhaust Filters And R-009-30 and R-015-30 Vacuum Pump Inlet Filters

Installation, Operation, and Maintenance Manual

These instructions must be thoroughly read and understood before installing and operating this product. If you have any questions or concerns, please call the Technical Services Department at 800-343-4048, 8AM to 5PM Eastern Time or email at balstontechsupport@parker.com (North America only). For other locations, please contact your local representative.

General Description

When properly installed, Parker vacuum pump filters remove 99.9% at 0.1 micron of oil mist and smoke from vacuum pump exhaust. They will also remove relatively high concentrations of solids and liquids from vacuum pump inlet flow.

Installation

Filter Housing Installation exhaust - The filter must be installed so that flow through the filter element is from inside-to-outside. The inlet of the filter is located next to the 1/8" NPT drain port. Simply attach this end of the filter assembly to the outlet of the vacuum pump. If an adaptor is required contact Technical Services Dept (800-343-4048). Oil may be automatically drained back to the vacuum pump through the gas ballast if your pump is so equipped. When putting a filter in service always make sure the cover is secured by lining up the arrow on the housing body with the padlock image on the cover.

- Install vertically for drainage
- Apply pipe sealant to male threads before connecting to the pump to eliminate leakage



- **Do not exceed 15 psi pressure rating of housing**

Filter Housing Installation, Inlet - The filter must be installed so that flow through the filter element is from inside-to-outside. The inlet of the filter is located next to the 1/8" NPT drain port which is plugged for applications requiring only solid contaminate removal. If liquid removal is required the plug can be replaced with a vacuum tight valve for easy draining or to a sealed catch pot. The outlet is located on the cover of the filter assembly. Simply attach this end (outlet) of the filter assembly to the inlet of the vacuum pump. When putting a filter in service always make sure the cover is secured by lining up the arrow on the housing body with the padlock image on the cover.

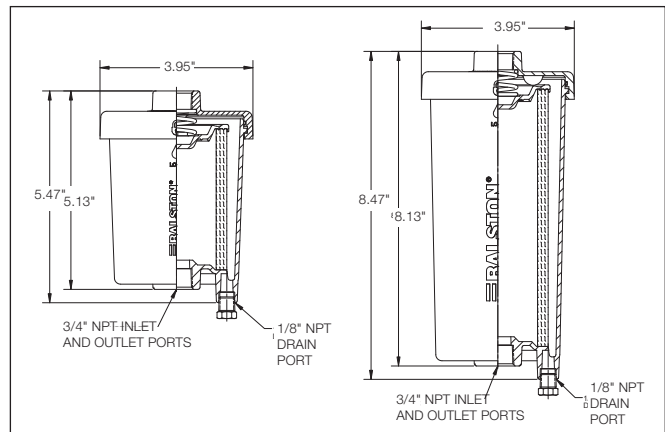

Figure 1: Parker Balston Vacuum Pump Filters with Dimensions

- The inlet filter may installed "in-line" or horizontally for applications requiring only solid contaminate removal.
- The inlet filter must be installed vertically if liquid contaminate removal is required.
- Apply pipe sealant to male threads before connecting to the pump to eliminate leakage
- **Do not exceed vacuum service to 2 Torr otherwise the filter assembly may begin to leak or slowly collapse**



Operation

Filter Cartridge Installation, Exhaust and Inlet - Balston Microfibre filter cartridges are sealed in place by compression against the bottom of the filter housing. Gaskets are not required between the filter cartridge and the housing, as compression is maintained by an internal spring. The filter cartridge is centered by guides on the housing which fit the inside diameter on the bottom of the cartridge, and the end cap on top.

Filter Cartridge Life, Exhaust - The microfibre filter cartridge will operate at its initial retention efficiency rating even when wet with oil. The filter cartridges need to be changed only when the back pressure on the pump reaches an unacceptably high level as a result of build up of solid dirt in the cartridge. There is usually very low solids concentration in vacuum pump exhaust, therefore the life of the cartridge should be up to 12 months. It is good practice to change the filter cartridge out at least once every 12 months to ensure optimum vacuum pump and exhaust filter performance.

Filter Cartridge Life, Inlet - The microfibre filter cartridge will operate at its initial retention efficiency rating even when wet with liquid contaminate. The filter cartridges need to be changed only when the pumping speed of the pump reaches an unacceptably high level as a result of build up of solid dirt in the cartridge creating a restriction in initial pump down

flow. There is usually very low solids concentration in vacuum pump inlet applications, therefore the life of the cartridge should be 3 to 12 months. It is good practice to change the filter cartridge out at least once every 12 months to ensure optimum vacuum pump performance.

Filter Selection Chart

| Max. Pump Flow Rate | Recommended Filter Model No. |
|---------------------|------------------------------|
| 9 CFM | AR-009-371H or R-009-30 |
| 15 CFM | AR-015-371H or R-015-30 |

Replacement Parts

| Replacement Component | Part Number | Box of 10 | Box of 2 |
|----------------------------------|-------------|----------------|------------------|
| Exhaust Filter Cartridges | AR-009-371H | BE200-168-371H | 2/BE200-168-371H |
| | AR-015-371H | BE200-248-371H | 2/BE200-248-371H |
| Inlet Filter Cartridges | R-009-30 | BE100-163-30 | 2/BE100-163-30 |
| | R-015-30 | BE100-235-30 | 2/BE100-235-30 |
| Replacement Seal Sets | A05-0098 | | |
| Replacement Covers | C03-0019 | | |

Note: To ensure consistent product performance and reliability, use only genuine Balston replacement parts and filter cartridges.

System Specifications

| | All Models | AR-009-371H | AR-015-371H | R-009-30 | R-015-30 |
|-------------------------------------|------------|----------------|----------------|---------------|---------------|
| Materials of Construction | | | | | |
| Filter Body | Aluminum | → | → | → | → |
| Filter Cover | Aluminum | → | → | → | → |
| Seal | Viton | → | → | → | → |
| Spring | 302 SS | → | → | → | → |
| End Cap | Nylon 6/6 | → | → | → | → |
| Maximum Operating Conditions | – | 15 psig, 300°F | 15 psig, 300°F | 2 Torr, 180°F | 2 Torr, 180°F |
| Dimensions | – | 4" w x 5.5" h | 4" w x 8.5" h | 4" w x 5.5" h | 4" w x 8.5" h |
| Shipping Weight | – | 1 lb. | 1.25 lb. | 1 lb. | 1.25 lb. |

Parker Hannifin Corporation
 Industrial Gas Filtration and
 Generation Division
 4087 Walden Avenue
 Lancaster, NY 14086
 Tel: 716-686-6400 Fax: 877-857-3800
 www.balstonfilters.com

Parker Manufacturing (UK) Ltd
 Gas Separation & Filtration Division EMEA
 Dukesway, Team Valley Trading Estate
 Gateshead, Tyne & Wear, NE11 0PZ
 United Kingdom
 Ph: +44 (0)191 402 9000
 www.parker.com/gse

