

HYDROGEN GAS FILTERS

High Pressure / Medium Flow - (1/4" to 2")

The use of hydrogen gas is growing in demand in various markets and applications. This growth is increasing rapidly as the global requirement for a cleaner energy source is developed. Hydrogen gas is used in industrial processes, there are several examples, such as fuel cells for electricity generation and powering vehicles. Outside of power generation, hydrogen is used by industry for refining petroleum, treating metals, producing fertilizer and other chemicals, and processing foods.

A common requirement for all identified applications is that hydrogen gas requires 'cleaning', providing protection to the process. The level of removal of particulate within the gas stream has a direct relationship to the application requirements. There are several techniques available to obtain the required filtration and purification efficiencies that are unique to the application. These include mechanical/depth filtration, activated carbon, membrane and chemical. Other hydrogen purification methods are available, such as pressure swing adsorption, gas membrane separation and electrochemical separation.

The focused filtration methodology identified within this document is dry gas depth filtration. Filtration grades of 1 micron (93% efficient @ 0.01 micron) to 0.01 micron (99.9999% efficient @ 0.01 micron) are available. Typically, industry application requirements are for filtration grades of 1 micron. Maximum operating pressures differ between port sizes, with a maximum pressure rating of 345 barg available.

Parker glass microfibre filter elements are designed for highly efficient particulate removal. A random bed of borosilicate glass fibres are held in a rigid structure by the fluorocarbon resin binder. Typically used for solids and relatively large amounts of suspended liquids in gases. Offering excellent chemical resistance, and temperature resistance to 150°C, these cartridges have thick walls for improved coalescing efficiency and are ideal for use with hydrogen gas both depth and coalescing applications.



Applications

- Fuel cells
- Power generation
- Petroleum refinement
- Metal treatment
- Fertilizer/chemical production
- Food processing

Technical Specifications

Model	Connections (NPT)		*Filtration Efficiency: 1 micron (93% efficient@ 0.01 micron)			Maximum Pressure		Operating Temperature		Element Code	Teflon [†] Seal Kit
			Gas Flow Rate (m ³ /hr) at								
	Inlet/Outlet	Drain	Maximum Rated Pressure	50% Rated Maximum Pressure	25% Rated Maximum Pressure	barg	psig	Minimum °C (°F)	Maximum °C (°F)		
EU85	¼"	¼"	11,443	5,493	2,258	345	5003	-38 (36.4)	150 (302)	050-11-	22085
EU37/12	½"	⅛"	19,182	9,207	3,946	276	4003	-38 (36.4)	150 (302)	100-12-	22132
EU37/25	½"	⅛"	27,129	13,022	6,167	276	4003	-38 (36.4)	150 (302)	100-25-	22132
EU27/35	1"	¼"	11,757	5,996	3,058	55	798	-38 (36.4)	150 (302)	200-35-	22028
EU27/35-3000	1"	¼"	46,251	22,200	13,764	206	2987	-38 (36.4)	150 (302)	200-35-	22028
EU27/80	1"	¼"	12,794	6,525	3,328	55	798	-38 (36.4)	150 (302)	200-80-	22028
EU27/80-3000	1"	¼"	50,421	10,440	13,484	206	2987	-38 (36.4)	150 (302)	200-80-	22028
EU15/80S6	2"	¼"	31,912	15,275	8,300	35	508	-38 (36.4)	150 (302)	200-80-	22146

*Filter Grade D. Both coalescing and solids depth capture elements available for housings listed. Examples. EU85: 050-11-DX (coalescing), EU37/12: 100-12-DQ (particulate)

†Supplied with Viton seals as standard, optional Teflon seals available for Hydrogen applications.

Hydrogen flows calculated at NTP - Normal Temperature & Pressure is defined as air at 20°C and 1 atm. Filters may be installed in parallel to increase flow rates.

Where applicable all housings detailed conform to EU PED directive 2014/68/EU. Outside of PED, technical specifications conform to ASME Section VIII, div. 1 - latest edition.

Weights & Dimensions

Model	Dimensions				Weight	
	Height		Width			
	mm	ins	mm	ins	kg	lbs
EU85	127	5.0	64	2.5	1.8	3.9
EU37/12	157	6.2	70	2.8	2.7	5.9
EU37/25	260	10.2	70	2.8	4.5	9.9
EU27/35	406	16.0	110	4.3	7.3	16.1
EU27/35-3000	406	16.0	110	4.3	7.3	16.1
EU27/80	685	27.0	101	4.0	9.1	20.1
EU27/80-3000	685	27.0	101	4.0	9.1	20.1
EU15/80S6	710	28.0	160	6.3	14.5	32

Materials of Construction

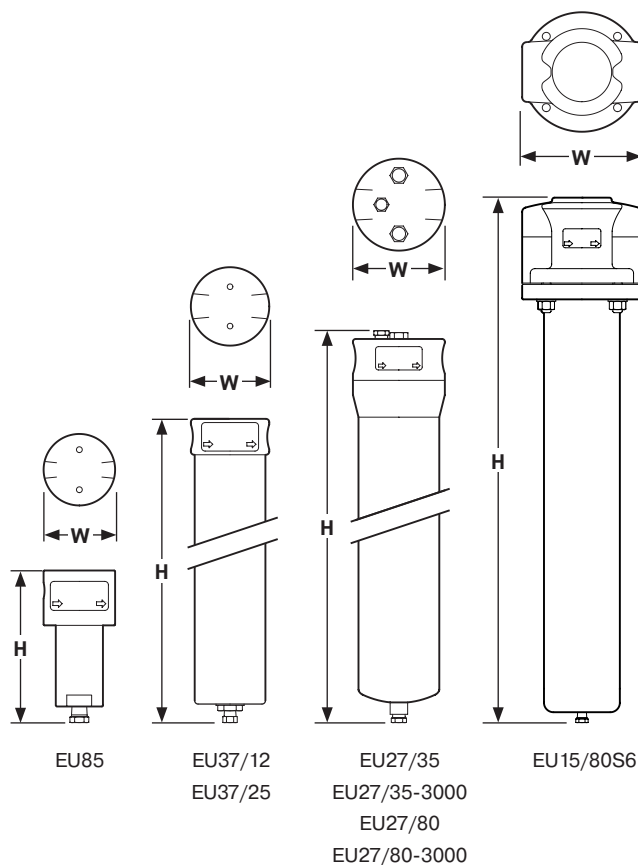
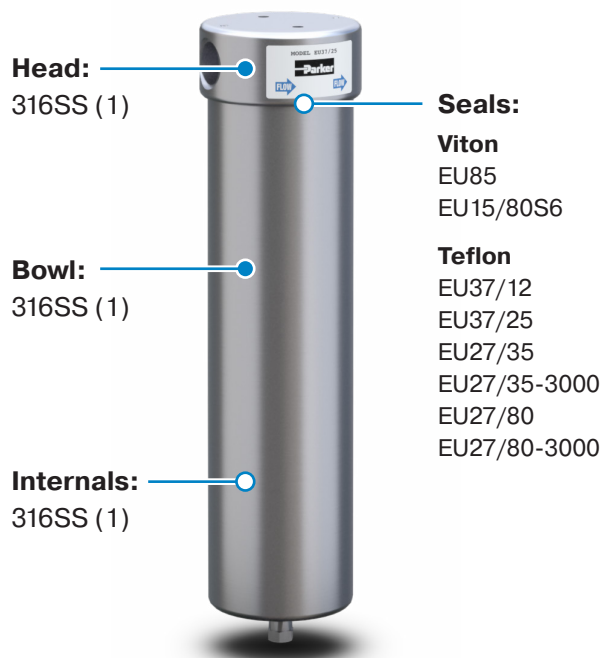

Parker Hannifin Corporation
Gas Separation and Filtration Division EMEA
 Dukesway, Team Valley Trading Estate
 Gateshead, Tyne & Wear, United Kingdom

www.parker.com/gsf

Reference: PISHYDR_00_EN

© 2024 Parker Hannifin Corporation

NOTES

- Constructed of materials which comply with NACE Specification MR-01-75. Certificate of compliance available on request.
- Maximum temperature rating is limited to media limits, Q and X grades. For higher temperatures, consult the factory.
- Teflon/PTFE Seals are the preferred material for for H2 applications, Teflon to be ordered separately. Viton is also compatible with H2 gas and is standard as fitted.

