

INSTALLATION MANUAL READY PUMPS

Effective: January, 2025

Supersedes: February 2024

Table of Contents

1.0 Document abstract	4
1.1 Naming conventions	4
2.0 Types of Direct Coupling lubrications	4
3.0 Parker eReady portfolio	6
4.0 Available interfaces	6
4.1 Motor spline.....	6
4.2 Pilot	7
4.3 Flange pattern	7
4.4 O-Ring specification for coupling chamber	8
4.5 Vertical mount	8
5.0 Greased Lubrication	8
5.1 Application guidance	8
5.1.1 Recommended Grease Type	8
5.1.2 Grease application	9
5.2 O-Ring installation	10
5.3 Service intervals	10
5.4 Limitations.....	10
6.0 Wet spline Lubrication	11
6.1 O-Ring installation.....	11
6.2 Service intervals	11
6.3 Limitations.....	11
6.3.1 Mounting options	11

7.0 Maintenance-free lubrication	12
7.1 Application guidance	12
7.1.1 Required Toolset	12
7.2 Mounting requirements	13
7.2.1 Horizontal mount	13
7.2.2 Vertical mount – Motor on bottom	13
7.2.3 Vertical mount – Motor on top	13
7.3 O-Ring installation	13
7.4 Service intervals	14
7.5 Limitations	14
7.5.1 System shut-down	14
8.0 Pump and motor Support.....	15
8.1 General structural requirements	15
8.2 Noise reduction and vibration dampening	15
8.3 Tribosystem improvements.....	15
9 References	16
10 List of figures	17
11 List of tables	17

1.0 DOCUMENT ABSTRACT

This manual covers the procedure, limitations, requirements and key points to consider for mounting the Parker eReady hydraulic units to an electric motor, especially the Parker GVM.

The scope of the manual is limited to the mechanical direct coupling between the two shafts. For hydraulic and electrical connections refer to relevant product documentation for the hydraulic unit and the electric motor.

Parker offers three lubrication types for the shaft connection. Make sure all requirements, stated in the sections below, are fulfilled irrespective of lubrication type and

electric motor. Failing to do so may result in hardware damage and/or personal injury.

Consider also reading documentations mentioned in References.

1.1 Naming conventions

- eReady components
 - Qualified to work in electrified systems
- Configured ePumps
 - EHP – Product designation (Electro-Hydraulic Pump)



eReady components - eReady Pumps, Motors, Inverter



Configured ePumps

Figure 1 Naming convention

2.0 TYPES OF DIRECT COUPLING LUBRICATIONS

Parker offers three lubrication types for shaft connection between eReady hydraulic unit and electric motor; namely greased spline lubrication, wet spline lubrication and maintenance-free lubrication. The design of all lubrication types allows for a direct con-

nection between the hydraulic unit and electric motor i.e. without using a bell-housing. Thus, resulting in lower system cost and length and higher power density.

Comparison of the lubrication types is shown in **Figure 2**.

SPLINE LUBRICATION TECHNOLOGIES

To avoid fretting corrosion



GOOD	BETTER	BEST
<p>Greased Spline</p>	<p>Wet Spline</p>	<p>Parker's Maintenance-Free Spline (Patented)</p>
 <p>A greased lube closed connection</p>	 <p>Oil-bath lubed open spline connection</p>	 <p>Oil flow created to actively lubricate the spline connection</p>
 <p>Grease is manually applied to spline connection</p>	 <p>Shaft splines are partially or fully submerged in a bath of hydraulic oil</p>	 <p>Case oil is pulled through the shaft by centrifugal forces created in the spinning shafts</p>
 <ul style="list-style-type: none"> Requires re-greasing Maintenance interval dependent on the application and duty cycle 	 <ul style="list-style-type: none"> Maintenance may be required Frequency is dependent on application 	 <ul style="list-style-type: none"> Maintenance-free
 <p>Horizontal & Vertical</p>	 <p>Horizontal</p>	 <p>Horizontal & Vertical</p>
<ul style="list-style-type: none"> Simple solution for many applications Grease breaks down over time; higher temperatures increase degradation In vertical orientation, a pocket of air may develop inside the pump reducing shaft seal life 	<ul style="list-style-type: none"> Robust for many applications In some cases, the absence of positive flow can prevent old oil from being flushed out with fresh oil 	<ul style="list-style-type: none"> Eliminates the risk of fretting corrosion in all applications This positive flow solution ensures that the splines are always lubricated with fresh case oil, regardless of mounting orientation, optimizing the reliability

Figure 2 Comparison of lubrication types

3.0 PARKER EREADY PORTFOLIO

The Parker eReady pump and motor portfolio can be found in the configured [ePump catalog](#).

4.0 AVAILABLE INTERFACES

4.1 Motor spline

The GVM comes with the following tolerances per SAE class as shown below in **Table 1**.

Interface size	Spline tolerance class		
	GVM142	GVM210	GVM310
SAE-A	5	5	
SAE-B	5	5	
SAE-C		5	5
SAE-D			6
DIN ISO		Sliding seat	

Table 1 SAE and DIN-ISO tolerance class per ANSI B92.1/ DIN ISO-7653 and GVM frame

Consider that the eReady units have been qualified with the GVM motor. That means the outlined spline lubrication performance can only be assured with a motor spline of a tolerance class higher or equal to the above mentioned fits.

4.2 Pilot

Especially for direct coupled shafts it is extremely important to align both of them as good as possible to prevent forces due to misalignments. The Parker eReady pump and motor portfolio has been tested to work with the Parker GVM.

The tolerances on the hydraulic side of the centering are prescribed by the SAE J744 standard.

For the female centering diameter no such standard exists. The GVM offers connections with the tolerances according to **Table 2**.

Interface size	Pilot Ø in mm		
	GVM142	GVM210	GVM310
SAE-A	82.63 – 82.68	82.63 – 82.68	
SAE-B		101.68 – 101.73	
SAE-C		127.08 – 127.13	127.08 – 127.13
SAE-D			152.50 – 152.55
DIN ISO		80.00 – 80.046	

Table 2 Female pilot centering dimensions and tolerances per ANSI B92.1/ DIN ISO-7653

When using a third party motor, make sure the female pilot dimensions fall in between these limits, to guarantee a fretting free operation.

4.3 Flange pattern

Interface size	Pilot Ø in mm		
	GVM142	GVM210	GVM310
SAE-A	2-bolt M10 (40 Nm)	2-bolt M10 (40 Nm)	
SAE-B		2-bolt M12 (70 Nm)	
SAE-C		4-bolt M12 (70 Nm)	2 and 4-bolt M12 (70 Nm)
SAE-D			4-bolt M16 (167 Nm)
DIN ISO		4-bolt M12 (70 Nm)	

Table 3 Mounting bolt pattern and bolt size per ANSI B92.1/ DIN ISO-7653 and tightening torque for mounting the hydraulic unit to the electric motor aluminum flange

The type and grade of bolts should be chosen to suit the level of shock and vibration the system is exposed to. Minimum requirement grade 5 bolts, for more aggressive applications, please reach out to Parker.

4.4 O-Ring specification for coupling chamber

The specifications of the O-rings for each interface can be found in **Table 4**.

Interface size	O-ring diameter	O-ring thickness	Parker number
SAE-A	75.92 mm	1.78 mm	2-041
SAE-B	101.27 mm	2.62 mm	2-155
SAE-C	120.32 mm	2.62 mm	2-158
SAE-D	145.72 mm	2.62 mm	2-162
DIN ISO	75.92 mm	1.78 mm	2-041

Table 4 O-ring specification for GVM front flange

4.5 Vertical mount

For all applications in vertical mounting direction, check the bearing lifetime and the allowed axial shaft load of the GVM. You will find according information in the GVM catalog, linked under References in this document.

5.0 GREASED LUBRICATION

5.1 Application guidance

5.1.1 Recommended grease type

High temperature, high performance grease is required.

Contact Parker for recommended grease type to lubricate the spline interface.

5.1.2 Grease application

	Instruction
	<p>Apply grease with brush on pump (male) spline</p>
	<p>Fill one-third of electric motor (female) spline cavity with grease</p>
	<p>Check during assembly process that grease is visible outside spline interface</p>

Table 5 Grease application instruction for direct mounting

5.2 O-Ring installation

To prevent the grease from drying out and increase life-time and keep it working properly, Parker recommends sealing the coupling chamber against air. The GVM motor comes with an O-ring groove out of the box to seal against the hydraulic unit's flange. Remember to install the O-ring prior to fixing the pump to the motor.

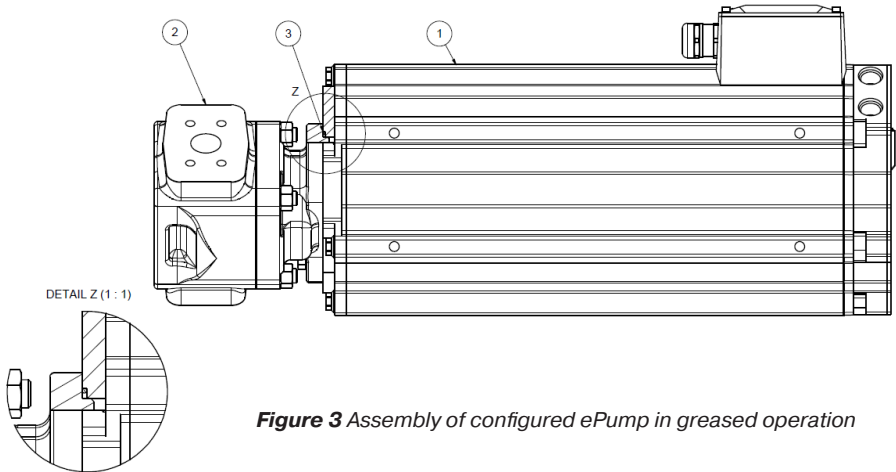

Figure 3 Assembly of configured ePump in greased operation

- 1) Electric motor (GVM)
- 2) Hydraulic unit (Gear pump)
- 3) O-ring

5.3 Service intervals

Any grease, though, will break down over time primarily dependent on the temperature within the spline connection. Testing has shown that any grease will break down at elevated temperatures, leading to fretting corrosion and costly maintenance. Re-greasing of the splines is required, with intervals depending on the application and duty cycle.

5.4 Limitations

None

6.0 WET SPLINE LUBRICATION

For this lubrication type, a GVM in wet-spline configuration is necessary. Please consider when choosing a motor.

6.1 O-Ring installation

To properly seal the coupling chamber, an O-ring between the pump and the motor is required. The GVM motor comes with an O-ring groove out of the box to seal against the hydraulic unit's flange. Remember to install the O-ring prior to fixing the pump to the motor.

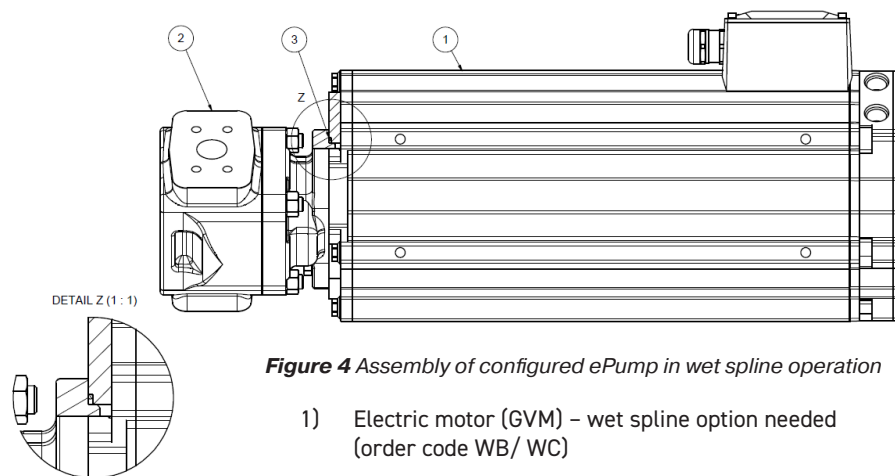

Figure 4 Assembly of configured ePump in wet spline operation

- 1) Electric motor (GVM) – wet spline option needed (order code WB/ WC)
- 2) Hydraulic unit (Gear pump)
- 3) O-ring

6.2 Service intervals

The case oil will become somewhat stagnant at the splines, as there may not be a positive flow in that area to fully flush out oil and replace with new. Inspection of the splines is required, with intervals depending on the application and duty cycle.

6.3 Limitations

6.3.1 Mounting options

6.3.1.1 Horizontal mount

None

6.3.1.2 Vertical mount – Motor on bottom

None

To avoid any air bubbles, prefill the hydraulic unit slowly, preferably by hand prior to start it up.

6.3.1.3 Vertical mount – Motor on top

Not allowed

7.0 MAINTENANCE-FREE SPLINE LUBRICATION

For this lubrication type, a GVM in wet-spline configuration is necessary. Please consider when choosing a motor.

7.1 Application guidance

7.1.1 Required toolset

Make sure to fill the female motor spline completely with grease and also cover the shaft seal and the cavity around it flush with the internal plane as shown in the table below. Grease the male pump spline (including the bore in the (connecting) shaft) and all cavities in the pilot flush with the end of the centering cylinder as shown in the table below as well. A paraffin based, oil solvent lubricant grease (e.g. **Castrol VAS Optileb**) is recommended by Parker. It doesn't influence the tendency of the oil to build foam, the viscosity and can be completely dissolved without blocking filter elements as no solid residues will remain as long as your system is running on HLP (mineral) type oils. To do so, a larger brush or a grease press is recommended.



	Instruction
	<p>Apply grease with brush or pump to motor interface and fill complete internal spline</p>
	<p>Apply grease to male spline, fill the bore and all internals of the pump (connecting) shaft and all the cavities in the pilot cylinder at least flush</p>

Table 6 Grease application instruction for direct mounting (maintenance-free spline)

7.2 Mounting requirements

7.2.1 Horizontal mount

None – pregreasing optional

7.2.2 Vertical mount - Motor on bottom

None – pregreasing optional

To avoid any air bubbles, prefill the hydraulic unit slowly, preferably by hand prior to start it up.

7.2.3 Vertical mount - Motor on top

Pregreasing mandatory

7.3 O-Ring installation

To properly seal the coupling chamber, an O-ring between the pump and the motor is required. The GVM motor comes with an O-ring groove out of the box to seal against the hydraulic unit's flange. Remember to install the O-ring prior to fixing the pump to the motor.

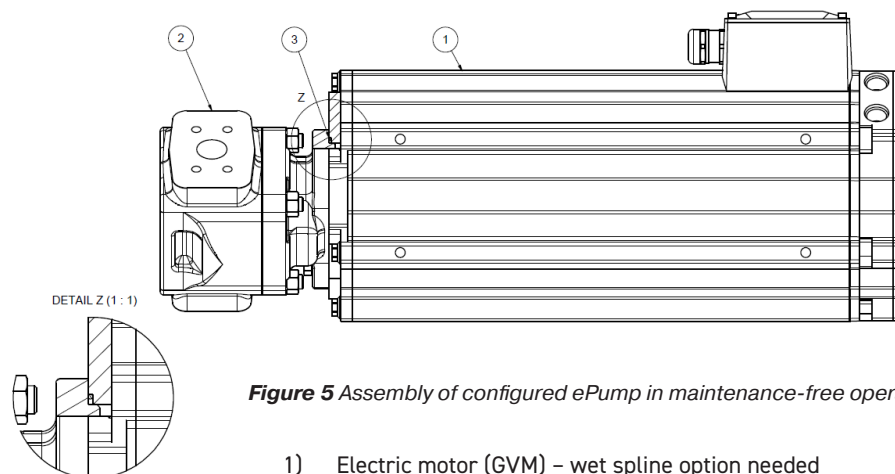

Figure 5 Assembly of configured ePump in maintenance-free operation

- 1) Electric motor (GVM) – wet spline option needed (order code WB/ WC)
- 2) Hydraulic unit (Gear pump)
- 3) O-ring

7.4 Service intervals

Lifetime lubrication achieved, no service needed.

7.5 Limitations

7.5.1 System shut-down

When putting the system to rest for a longer period of time, make sure the pump is always exposed to a positive pressure. In best case the reservoir is installed above the pump level or at least the drain line is led above the shaft connection as shown in system arrangement 3 in **Figure 6** to avoid emptying the coupling cavity. Arrangement 1 and 2 increase the risk of not keeping the oil inside the cavity during shut-down. It is also important to keep the pump filled with oil when the circuit is opened to maintain the quality or exchange components in the same hydraulic circuit. If this cannot be assured and the pump bleeds out due to circuit maintenance or longer phases of system rest, make sure to regrease the cavity according to **Table 6** before starting up the system again.

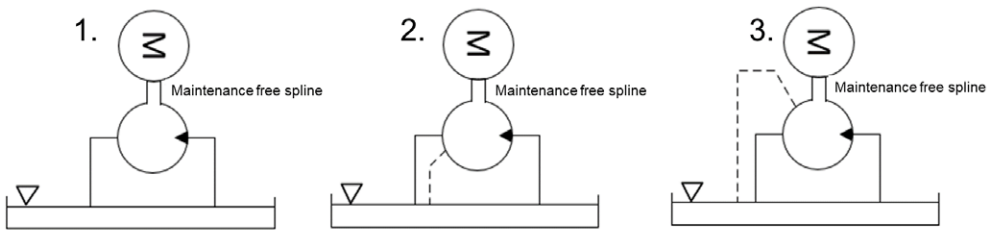

Figure 6 Tank level position

8.0 PUMP AND MOTOR SUPPORT

8.1 General structural requirements

For the hydraulic unit's weight limit please refer to the GVM catalog. Make sure to support the assembly properly if needed.

A cast iron motor flange can be available on request if environmental factors require higher stiffness.

8.2 Noise reduction and vibration dampening

Installation of pump and motor can have an impact on noise and vibration level.

Three main methods of isolation are proposed to reduce the transmitted vibration energy between a source and a surface consisting of: mass blocking, mass-spring system and internal damping.

Radiated sound power can also be reduced through encapsulation.

Refer to [Bulletin MSG30-9000 UK](#) for more details.

8.3 Tribosystem improvements

Within the first hours of operation the pump's efficiency can still improve since the tribo-mechanical system is evolving. Time to optimal efficiency depends on product type.

9.0 REFERENCES

Motor documentations



[GVM142 series](#)



[GVM210/310 series](#)

Pump catalogues



[Gear pumps PGM series](#)



[Mobile axial pistons pumps P2/P3](#)



[Mobile axial piston pumps
P1M series](#)



[Bent axis pumps F11/F12 series](#)



[Bent axis pumps F1, VP1 series](#)



[Vane pumps T7 series](#)

Service manuals



[Gear pumps PGM series
service manual](#)



[Mobile axial pistons pumps
P2/P3 service manual](#)



[Axial piston pumps P1M series
service manual](#)



[Bent axis F12 series
service manual](#)



[Bent axis F1 series
service manual](#)



[VP1 series service manual](#)



[Vane pumps service manual](#)

Webpage



www.parker.com/ehp

Please mind that the above list does not claim to contain every information needed for specific applications.

10.0 LIST OF FIGURES

Figure 1 Naming convention	4
Figure 2 Comparison of lubrication types	5
Figure 3 Assembly of configured ePump in greased operation	10
Figure 4 Assembly of configured ePump in wet spline operation	11
Figure 5 Assembly of configured ePump in maintenance-free operation	13
Figure 6 Tank level position.....	14

11.0 LIST OF TABLES

Table 1 SAE and DIN-ISO tolerance class per ANSI B92.1/ DIN ISO-7653 and GVM frame.....	6
Table 2 Female pilot centering dimensions and tolerances per ANSI B92.1/ DIN ISO-7653	7
Table 3 Mounting bolt pattern and bolt size per ANSI B92.1/ DIN ISO-7653 and tightening torque for mounting the hydraulic unit to the electric motor aluminum flange.....	7
Table 4 O-ring specification for GVM front flange	8
Table 5 Grease application instruction for direct mounting	9
Table 6 Grease application instruction for direct mounting (maintenance-free operation)	12

Position notification regarding Machinery Directive 2006/42/EC:

Products made by the Hydraulic Pumps & Motors Europe (HPME) of Parker Hannifin are excluded from the scope of the machinery directive following the "Cetop" Position Paper on the implementation of the Machinery Directive 2006/42/EC in the Fluid Power Industry.

All HPME products are designed and manufactured considering the basic as well as the proven safety principles according to:

- ISO 13849-1:2015
- SS-EN ISO 4413:2010

so that the machines in which the products are incorporated meet the essential health and safety requirements.

Confirmations for components to be proven component, e. g. for validation of hydraulic systems, can only be provided after an analysis of the specific application, as the fact to be a proven component mainly depends on the specific application.

Christian Jäger

General Manger

Hydraulic Pumps & Motors Europe



WARNING – USER RESPONSIBILITY

FAILURE OR IMPROPER SELECTION OR IMPROPER USE OF THE PRODUCTS DESCRIBED HEREIN OR RELATED ITEMS CAN CAUSE DEATH, PERSONAL INJURY AND PROPERTY DAMAGE.

This document and other information from Parker-Hannifin Corporation, its subsidiaries and authorized distributors provide product or system options for further investigation by users having technical expertise.

The user, through its own analysis and testing, is solely responsible for making the final selection of the system and components and assuring that all performance, endurance, maintenance, safety and warning requirements of the application are met. The user must analyze all aspects of the application, follow applicable industry standards, and follow the information concerning the product in the current product catalog and in any other materials provided from Parker or its subsidiaries or authorized distributors.

To the extent that Parker or its subsidiaries or authorized distributors provide component or system options based upon data or specifications provided by the user, the user is responsible for determining that such data and specifications are suitable and sufficient for all applications and reasonably foreseeable uses of the components or systems.

OFFER OF SALE

Please contact your Parker representation for a detailed "Offer of Sale".

Parker Hannifin Manufacturing Germany GmbH & Co KG

Hydraulic Pumps & Motors Europe

Neefestraße 96

09116 Chemnitz, Germany

Tel: +49 (0)371 - 3937 - 0

Fax: +49 (0)371 - 3937 - 488

parker.com/msge

MSG30-2905-INST/UK

Your Local Authorized Parker Distributor

© 2025 Parker Hannifin Corporation

