

P33 Safety Exhaust Valve Integration Guide

FRL-SIF-120_EU



ENGINEERING YOUR SUCCESS.

Warning, Offer of Sale

Integration Guide

Parker P33 Safety Exhaust Valve

General Information

Pulse Testing 1
 Exhaust Rate 2
 Soft Start 3
 Sensors 4
 General Operation Guide (LED Status and Specifications)..... 5-7

Operating Information

Operation 8
 Monitoring Logic 9
 Validation..... 10-11

Integration Guide (Safe Relay with Standard PLC for Cat 3 PL d)

Rockwell (440R) 13-15
 Schmersal (SRB) 16-17
 Siemens (Sirius 3SK1112)..... 18-21

Integration Guide (Programmable Safe Relay for Cat 4 PL e)

Omron (G9SP) 23-25
 Pilz (PNOZ) 26-27
 Rockwell Guardmaster (440C-CR30)..... 28-31

Integration Guide (Safe PLC I/O for Cat 4 PL e)

Molex / Brad (TCDEC-8B4P / TCDEC-8B4B) 33-35
 Rockwell ArmorBlock Guard (1732ES-IB8XOB8) 36-37
 Rockwell ArmorBlock Guard (1732ES-IB8XOBV4) 38-39
 Rockwell Point Guard (1734-OB8S / 1734-IB8S) 40-42
 Siemens (ET200PRO)..... 43-44
 Siemens (Simatic S7) 45-48
 Turck (TBPN) 49-51

⚠ WARNING

FAILURE OR IMPROPER SELECTION OR IMPROPER USE OF THE PRODUCTS AND/OR SYSTEMS DESCRIBED HEREIN OR RELATED ITEMS CAN CAUSE DEATH, PERSONAL INJURY AND PROPERTY DAMAGE.

This document and other information from Parker Hannifin Corporation, its subsidiaries and authorized distributors provide product and/or system options for further investigation by users having technical expertise. It is important that you analyze all aspects of your application including consequences of any failure, and review the information concerning the product or system in the current product catalog. Due to the variety of operating conditions and applications for these products or systems, the user, through its own analysis and testing, is solely responsible for making the final selection of the products and systems and assuring that all performance, safety and warning requirements of the application are met.

The products described herein, including without limitation, product features, specifications, designs, availability and pricing, are subject to change by Parker Hannifin Corporation and its subsidiaries at any time without notice.

Offer of Sale

The items described in this document are hereby offered for sale by Parker Hannifin Corporation, its subsidiaries or its authorized distributors. This offer and its acceptance are governed by the provisions stated on the separate page of this document entitled "Offer of Sale".



Introduction

Parker offers a variety of safety valves for use in various safety functions such as safe exhaust, safe cylinder, return, and safe load holding/stop. This document focuses specifically on valves that use sensors to provide feedback to a safety control system for external monitoring.

While all potential electrical safety control suppliers and solutions cannot be covered this document provides a template for the most common suppliers and their devices.

Each solution has been designed to meet a specific category and performance level based on ISO 13849. Meeting this levels requires other aspects of the system meet these requirements such as but not limited to plumbing, wiring, and pulse testing.

Wiring examples are provided in this document and are shown using specific connections as wired and tested, but there may be other terminals available to use on the various controllers. These are just examples.

This integration guide is intended to assist you in integrating the product into your control circuit however; programs provided in this integration guide are for reference only. These programs have not been certified or tested unless indicated otherwise.

Pulse Testing

In dual channel safety circuits, pulse testing is a method utilized to detect short circuit conditions that, without pulse testing, can mask other fault conditions. Pulse testing of the solenoids is encouraged and will not affect the performance of the Parker valves. However, pulse testing of feedback sensors is not required.

Exhaust Times and Faulted Flow Rates

When designing a safety circuit, the machine stopping time is critical to the placement of guarding equipment – safe distance. One factor in safe distance calculations is the exhaust time of the valve that is responsible for isolating and dumping the pneumatic energy from the machine. The faster your valve exhausts the quicker the machine can stop and the closer your safety devices may be placed to the hazardous area. This can improve the overall operating efficiency, and possibly allow the footprint of the machine to be smaller.

Even more important than exhaust times is the “Faulted exhaust flow rate”. Faulted exhaust flow rate is the exhaust rate of the valve in its worst state. Double valves (redundant valve systems used for safety applications) will not exhaust quite as quickly when there is an internal fault condition in the valve such as when one of the redundant valve components is actuated and the other one is not actuated. For this reason, double valves used in safety circuits should always be sized using faulted flow rates as the worst case condition.

The chart below shows Parkers very high flowing faulted exhaust flow times.

Exhaust Time - Normal and Faulted Conditions (s)

Volume ft ³ (L)	Normal or Faulted	Operating Pressure					
		30 psig (2 bar)		90 psig (6 bar)		145 psig (10 bar)	
		to 15 psig (1 bar)	to 7 psig (0.5 bar)	to 15 psig (1 bar)	to 7 psig (0.5 bar)	to 15 psig (1 bar)	to 7 psig (0.5 bar)
0.071 (2)	N	0.05	0.07	0.09	0.11	0.12	0.14
	(F)	0.07	0.10	0.15	0.18	0.20	0.25
0.35 (10)	N	0.13	0.21	0.32	0.39	0.42	0.51
	(F)	0.18	0.30	0.53	0.71	0.79	1.02
0.70 (20)	N	0.23	0.38	0.60	0.75	0.80	0.97
	(F)	0.33	0.56	1.02	1.37	1.53	2.00
1.41 (40)	N	0.42	0.72	1.16	1.45	1.56	1.90
	(F)	0.61	1.06	1.98	2.69	3.00	3.94
5.29 (150)	N	1.46	2.60	4.23	5.33	5.74	7.01
	(F)	2.16	3.86	7.30	9.93	11.11	14.63

Exhaust Sound Pressure Level

The P33 Safety Exhaust Valve has a sound pressure level of 88dB*

*dB is based on faulted condition, average and peak at 30 psi.

Introduction

The function of the optional soft start module is to, on energization, allow outlet pressure to increase at a slower than normal rate until it reaches approximately 60% of inlet pressure, at which point the valve will then open fully to finish filling the system at full flow rate. This feature can be used to lessen the shock of sudden, rapid pressurization of cylinders, and to gradually refill the system.

The soft start module has an adjusting screw that is used to control the rate of pressurization according to number of turns and inlet pressure. The charts below can be used to approximate the number of turns (clockwise from full open) it will take in order to adjust the soft start for your system. The necessary setting is dependent upon the number of turns, inlet pressure, and downstream volume to be filled by the valve.

P33 Series Soft Start Adjustment - Flow vs Number of Turns and Inlet Pressure

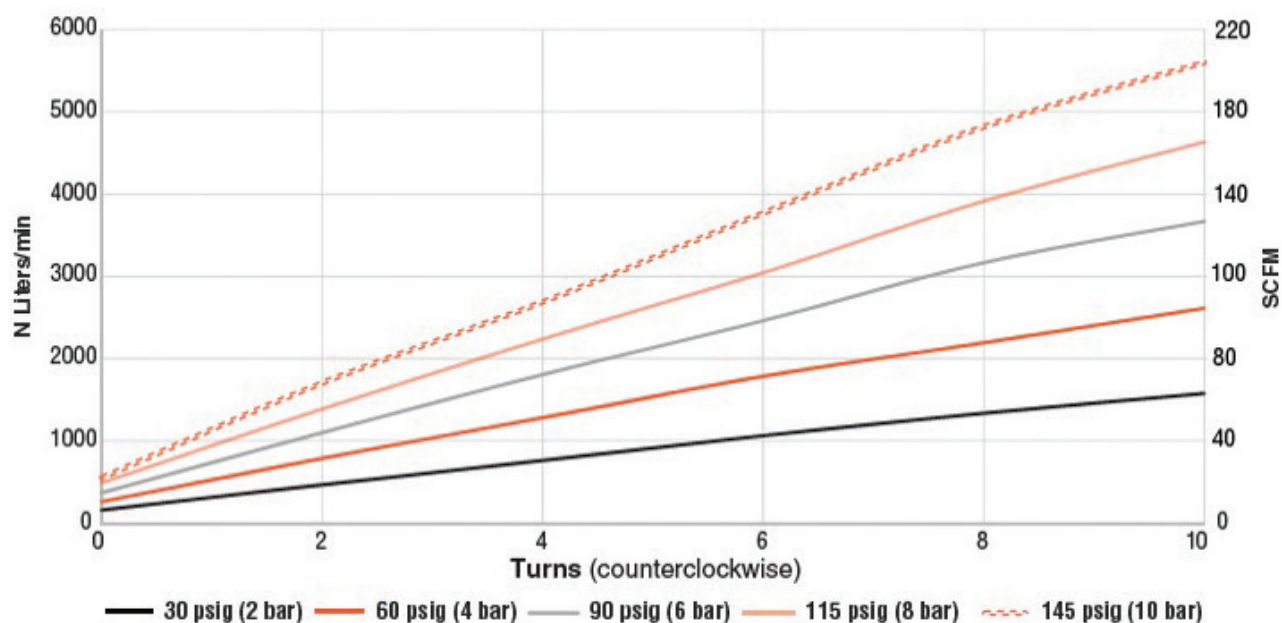

Soft Start Adjustment Guide (Turns Versus Input Pressure)

Measured in Nominal L/Min

Turns	2 bar	4 bar	6 bar	8 bar	10 bar
0	158.28	259.37	366.97	487.88	551.31
2	464.94	785.48	1098.37	1384.93	1700.37
4	759.43	1279.03	1803.72	2235.83	2687.18
6	1061.56	1782.77	2459.81	3042.83	3771.69
8	1333.68	2190.80	3165.72	3913.27	4820.51
10	1574.93	2611.30	3669.18	4633.06	5597.50
Full Open	1594.47	2665.10	3769.70	4897.81	5833.94

Measured in SCFM

Turns	29 PSI	58 PSI	87 PSI	116 PSI	145 PSI
0	5.59	9.16	12.96	17.23	19.47
2	16.42	27.74	38.79	48.91	60.05
4	26.82	45.17	63.70	78.96	94.90
6	37.49	62.96	86.87	107.46	133.20
8	47.10	77.37	111.80	138.20	170.24
10	55.62	92.22	129.58	163.62	197.68
Full Open	56.31	94.12	133.13	172.97	206.03

Pressure Sensor Option

An optional pressure sensor can be purchased for the P33 safety valve. The pressure sensor MPS-P34G-PCI is 1/8 BSPP male with M8 Male electrical connection and mates directly to the valve.

Features

- Sensor output:
 - 1 NPN or PNP Open collector
 - Transistor output, 30VDC, 125mA with
 - Analog output, 4 to 20mA
- Output response time less than 2.0 milliseconds
- RoHS
- Air and non-corrosive gases
- Sensor face includes icons to show sensor programming status



MPS-34 Sensor only ordering numbers

Pressure range	Electrical output	Electrical connection	Part number
0-145 PSI	(1) PNP with (1) 4-20ma	M8, 4 Pin	1/8 BSPP male MPS-P34G-PCI

Internal circuit for open collector and analog output wiring

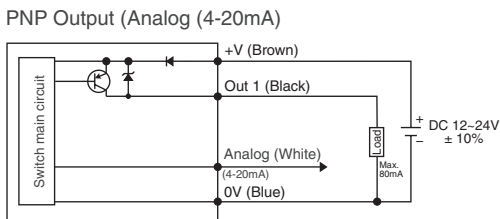

Sensor pin out with analog output

Pin #

- 1 Brown: 24VDC
- 2 White: 4 to 20mA
- 3 Blue: 0VDC
- 4 Black: PNP Open Collector Output 1

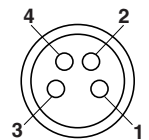

General Operation Guide (Schematics)

The Parker P33 schematic shows patented cross flow technology. Solid state pressure sensors are used in this design (in place of mechanical switches). The red box highlights the optional soft start in the unit.

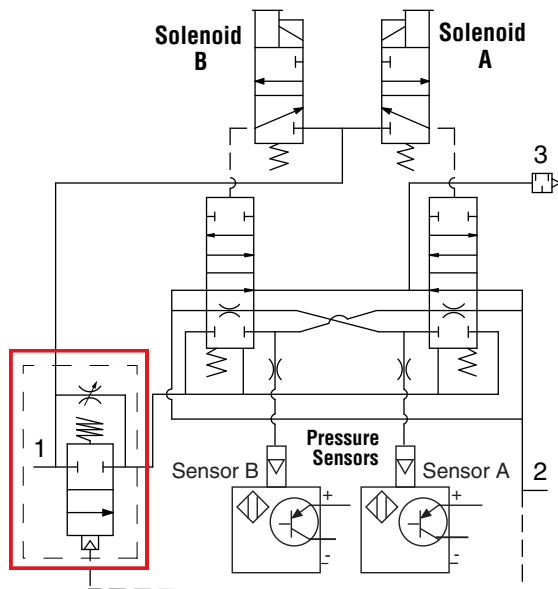

General Operation Guide (Dimensions)

Externally Monitored (with Soft Start)

Externally Monitored (No Soft Start)

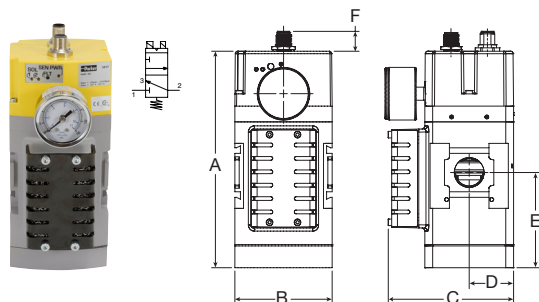
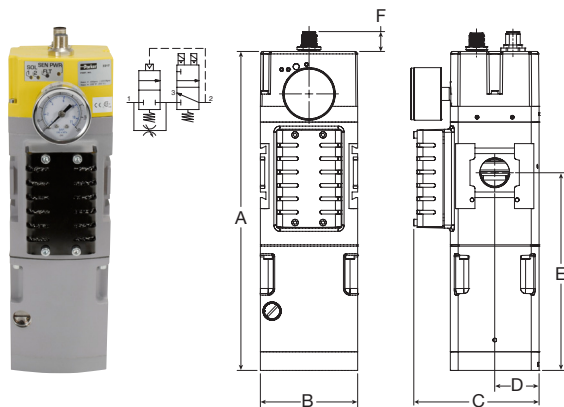

Dimensions

Ports	Standard nominal flow rate		A	B	C	D	E	F	
	1 → 2 L/min (SCFM)*	2 → 3 L/min (SCFM)*							
			inches (mm)						
Externally Monitored with soft start	3/4"	4,100 (145)	7,500 (265)	10.31 (261.9)	3.15 (80)	4.30 (109.3)	1.44 (36.5)	6.39 (162.3)	0.64 (16.3)
Externally Monitored no soft start	3/4"	4,300 (152)	7,500 (265)	7.03 (178.7)	3.15 (80)	4.30 (109.3)	1.44 (36.5)	3.11 (79.0)	0.64 (16.3)

* Standard nominal flow rate is based on 6 bar input pressure with ΔP = 1 bar

General Operation Guide (Wiring)

The P33 valve is available with various wiring options for both the solenoid cable and the sensor cable. For example, the following model number is wired internally with the DB wiring option:

Model Number: P33TB16DBEN

This means the valve in this example is wired with the D solenoid configuration and the B Sensor configuration. Use these diagrams to determine the proper pinouts for your valve.

Solenoid M12 Pinouts

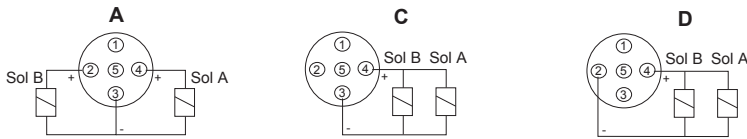

Pressure Sensor M12 Pinouts

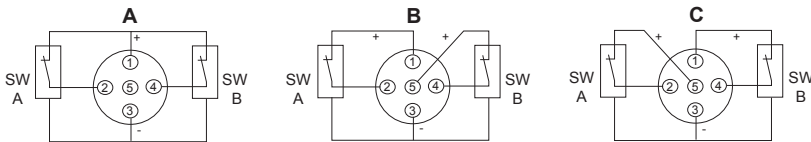

General Technical Data

Valve type	Externally monitored, redundant, dual poppet
Soft start	Optional
Valve function	3/2 way, normally closed
Housing material	Cast aluminum
Seals	NBR
Fasteners	Stainless steel / brass
Silencer	Steel, non clog safety design
Weight lbs (kg)	6.5 (2.9) with soft start 4.2 (1.9) without soft start

In accordance with EN ISO 13849-1 this safety valve is suitable for use up to Category 4, Ple, sil 3. Certified to cCSAus, CE mark.

Electrical Specifications

Operating voltage	24V DC
Electrical connection	Two M12 connectors
Switching time 1-2 (ms)	23.3
Switching time 2-3 (ms)	42.7
Duty cycle (%)	100%
Operating voltage (DC)	21.6 to 26.4
Nominal power	
per solenoid coil at 24V DC (W) +/- 10%	1.2 W
per pressure sensor at 24V DC	1.2 W

Specifications

Operating pressure PSIG (bar)	30 to 150 PSIG (2 to 10 bar)	Ingress protection class	IP65
Minimum operating pressure PSIG (bar)	30 PSIG (2 bar)	B10 (mio)	10 million switching cycles
Ambient temperature °F (°C)	40° to 120°F (4° to 50°C)	B10 _d (mio)	20 million switching cycles
Recommended filtration (µ)	40µ	Allowable discordance	150ms
Operating medium	Compressed air	Flow media	Compresses air to ISO 8573-1 Class 7:4:4

The soft start opens to full flow at approximately 60% of input pressure.

General Operation Guide (LED Status Lights)

FAULT (FLT):

Flashing Red: Sensors are in different states. The P33 unit will automatically fail to a mechanical safe state (no downstream pressure). The monitoring logic should automatically shut off power to both solenoids.

- If FLT light is flashing and either or both solenoid lights are ON it indicates the monitoring logic is not properly detecting this fault. The P33 unit should be powered down and monitoring logic reviewed and re-tested before putting into operation again.
- If FLT light is flashing and both solenoid lights are OFF it indicates the unit has an internal malfunction and should be replaced before continuing operation.

OFF : Sensors in same state – no issue

Solenoid Power (SOL 1/2):

Green: Power is properly applied to solenoid 1 and/or solenoid 2

OFF: No power is applied to the solenoids. Check connection from Solenoid M12 to output device

Sensor Power (SEN PWR):

Green: Power is properly applied to the sensors

OFF: No power to the sensors. Check connection from Sensor M12 to input



Operation & Monitoring Requirements

The intent of this document is to provide guidance on how to operate and monitor the P33 valve for safe operation. A test procedure is also provided for verification and validation of the user's external safety control monitoring system.

Valve Operation

The P33 valve is a redundant safety exhaust (dump) valve. Its function is that of a 3/2, normally closed, single-solenoid valve. However, because the valve is redundant it has two operating solenoids that must be operated simultaneously in order to actuate the valve.

Actuating the valve will supply pressure from port 1 (supply) to port 2 (outlet) and close port 3 (exhaust).

De-actuating the valve will close port 1 (supply) and open port 2 (outlet) to port 3 (exhaust). De-actuation of the valve is accomplished by turning off both solenoids simultaneously.

Valve Operation – Faulted Condition

In the event of a valve fault where one of the redundant valve components does not operate synchronously as commanded, the valve will perform its safety function which is to shut off supply and exhaust downstream pressure to atmosphere.

Synchronous operation occurs when both sets of valve internals shift within 150 msec of each other.

Failure of the valve to shift synchronously leads to a fault in the P33 valve. This could happen for a variety of reasons, such as:

- Defective piston seals
- Main valve elements experiencing a switching delay due to dirt, debris or resinous oil
- Insufficient electrical signals to valve solenoids; suitable voltage not available
- Receipt of signals at solenoids not synchronous
- Pilot valves experiencing a switching delay due to damaged components, dirt, debris or resinous oil
- Excessive water build-up in the valve

Monitoring of the Valve

The P33 valve is equipped with feedback pressure sensors that must be monitored by the user's external safety control monitoring system to detect any fault condition within the valve. Sensor feedback should always agree with the solenoid actuating signals.

Detection of any valve fault should disable the safety control outputs to the valve solenoids and prevent any subsequent attempts to actuate the valve until a safety control system reset is performed.

Refer to EN ISO13849-1 for cat 3 vs cat 4 monitoring.

Automatic RESET is not recommended by PARKER

Actuation Fault Monitoring

Actuation fault monitoring should check for valve actuation synchronicity. After the safety control system outputs provide simultaneous actuation signals to both solenoids, both sensor outputs should switch off within 150 msec of each other. Dependent upon which sensor switches off first, the following faults should be detected.

1. "A" side fault detection – if sensor A does not switch off within 150 msec after sensor B switches off, this should be registered as a fault.
2. "B" side fault detection – if sensor B does not switch off within 150 msec after sensor A switches off, this should be registered as a fault.

De-Actuation Fault Monitoring

De-Actuation fault monitoring should check for valve de-actuation synchronicity. After the safety control system simultaneously remove the actuation signals from both solenoids, both sensor outputs should switch on within 150 msec of each other. Dependent upon which sensor switches on first, the following faults should be detected.

1. "A" side fault detection – sensor A does not switch on within 150 msec after sensor B switches on, this should be registered as a fault.
2. "B" side fault detection – if sensor B does not switch on within 150 msec after sensor A switches on, this should be registered as a fault.

Monitoring of Supply Pressure

Loss of Supply Pressure While Actuated

The condition of loss of supply pressure while the valve is actuated must be detected by the safety control monitoring system. Loss of supply pressure while actuated should cause both sensors to switch on due to lack of pressure in both valves' outlet port even though the valve is still energized. This fault can be detected when the solenoids are high, and one or both sensors go from low (sensing pressure) to high (not sensing pressure).

No Supply Pressure Applied Before Actuation

Monitoring of supply pressure may also be utilized if deemed beneficial for the application but is not required. If you choose to detect this condition it would require the addition of an upstream pressure switch or transducer. The condition of the pressure switch or transducer should be monitored to prevent actuation of the valve when supply pressure is insufficient.

Safety System Reset

Any detected fault in the valve system should cause the safety control system to de-actuate the valve by removing power from both solenoids. A reset of the safety control system should only be possible after the valve sensors indicate that the valve is in the de-actuated state (both sensors switched on).

Test Procedure for Valve Operation and External Monitoring Logic

NOTE: This test procedure should only be performed with a P33 valve that is known to be functioning properly. If basic valve function is in question, please refer to Section 8 of the Product Operating Instructions for the Valve Test Procedure.

Valve Operation

1. Energize solenoids A & B simultaneously. Valve is on, air pressure is supplied downstream from supply port 1 through outlet port 2, and exhaust port 3 is shut off. Sensors A & B are off.
2. De-energize solenoids A & B simultaneously. Valve is off, supply port 1 is blocked, and downstream air is exhausted from outlet port 2 through exhaust port 3. Sensors A & B are on.

Test Procedure – Actuation Fault Monitoring (with Fault Latching)

*NOTE: These test procedures required fault simulation. It will be necessary to induce faults electrically by disabling one solenoid or the other at different times, which may require special test cabling in order to complete the test procedure. **Also, be aware that this would only be possible with solenoid wiring option A.** See product data sheet.*

3. Energize only solenoid A. This should result in a sensor A switching off while sensor B stays on. Your safety control monitoring system should detect this fault in the valve, where sensor A switches off and sensor B stays on more than 150 msec after sensor A switches off. This fault should trigger the safety outputs to switch off in order to de-energize both solenoids, A & B. The fault should be latched in by the safety control system logic until the system is reset. While the fault exists supply port 1 is blocked, and downstream air from outlet port 2 is open to exhaust port 3. Once the safety control system de-energizes the solenoids, sensors A and B should both be on.
4. Before attempting to reset the safety control system, attempt to energize both solenoids, A & B, simultaneously. Supply port 1 should remain blocked and downstream air from outlet port 2 should remain open to exhaust via exhaust port 3.
5. De-energize both solenoids A & B.
6. Reset the safety control system.
7. Energize only solenoid B. This should result in sensor A staying on while sensor B switches off. Your safety control monitoring system should detect this fault in the valve, where sensor B switches off and sensor A stays on more than 150 msec after sensor A switches off. This fault should trigger the safety outputs to switch off in order to de-energize both solenoids A & B. The fault should be latched in by the safety control system logic until the system is reset. While the fault exists, supply port 1 is blocked, and downstream air from outlet port 2 is open to exhaust port 3. Once the safety control system de-energizes the solenoids, sensors A and B should both be on.
8. Before attempting to reset the safety control system, attempt to energize both solenoids, A & B, simultaneously. Supply port 1 should remain blocked and downstream air from outlet port 2 should remain open to exhaust via exhaust port 3.
9. De-energize both solenoids A & B.
10. Reset the safety control system.

Test Procedure – De-Actuation Fault Monitoring (with Fault Latching)

NOTE: These test procedures required fault simulation. It will be necessary to induce faults electrically by disabling one solenoid or the other at different times, which may require special test cabling in order to complete the test procedure. Also, be aware that this would only be possible with solenoid wiring option A. See product data sheet.

1. Energize solenoids A & B, simultaneously. This switches the valve on and should result in air pressure being supplied downstream from supply port 1 through outlet port 2, and exhaust port 3 being shut off. Sensors A & B should both switch off.
2. De-energize only solenoid A. The safety control system should detect the fault in the valve where sensor A switches on and sensor B stays off more than 150 msec after sensor A switches on. This fault should trigger the safety outputs to switch off in order to de-energize both solenoids A and B. The fault should be latched in by the safety control system logic until the system is reset. While the fault exists supply port 1 is blocked and downstream air from outlet port 2 is open to exhaust port 3. Once the safety control system de-energizes the solenoids sensors A and B should be both on.
3. Before attempting to reset the safety control system, attempt to energize both solenoids A and B simultaneously. Supply port 1 should remain blocked and downstream air from outlet port 2 should remain open to exhaust via exhaust port 3.
4. De-energize both solenoids A & B.
5. Reset the safety control system.
6. Energize both solenoids, A & B simultaneously. This switches the valve on and should result in air pressure being supplied downstream from supply port 1 through outlet port 2, and exhaust port 3 being shut off. Sensors A & B should be both switched off.
7. De-energize only solenoid B. The safety control system should detect the fault in the valve where sensor B switches on and sensor A stays off more than 150 msec after sensor B switches on. This fault should trigger the safety outputs to switch off in order to de-energize both solenoids, A & B. The fault should be latched in by the safety control system logic until the system is reset. While the fault exists supply port 1 is blocked, and downstream air from outlet port 2 is open to exhaust port 3. Once the safety control system de-energizes the solenoids, sensors A and B should both be on.
8. Before attempting to reset the safety control system, attempt to energize solenoids, A & B simultaneously. Supply port 1 should remain blocked and downstream air from outlet port 2 should remain open to exhaust via exhaust port 3.
9. De-energize both solenoids A & B.
10. Reset the safety control.

Test Procedure for Loss of Supply Pressure While Actuated

1. Energize both solenoids, A & B, simultaneously. This switches the valve on and should result in air pressure being supplied downstream from supply port 1 through outlet port 2, and exhaust port 3 being shut off. Sensors A & B should both switch off.
2. Remove supply air from supply port 1. Sensors A & B should switch on. External monitoring should detect the fault in the valve where both solenoids are on, but both sensors are also switched on. This fault should trigger the safety outputs to switch off in order to de-energize both solenoids, A & B. The fault should be latched in by the safety control system logic until the system is reset. While the fault exists, supply port 1 is blocked, and downstream air from outlet port 2 is open to exhaust port 3. Sensors A and B should remain on.
3. Re-supply air to supply port 1. Supply port 1 is blocked and downstream air from outlet port 2 is open to exhaust via port 3. Sensors A & B should both be on. Re-supplying air while the fault is latched in the safety control system should not result in air being supplied from supply port 1 to outlet port 2.
4. Reset the safety control system.

Integration Guide (Safe Relay with Standard PLC) (for applications requiring Cat 3 PL d)

Rockwell 440R-D22S2



Part Number: 440R-D22S2

Functional Safety Rating: Cat 4, PL e

- Uses terminals
- Customer will have colored wires
- Can be wired with a PLC for sensors monitoring
- Examples include with and without pin outs and valve schematic

Generic Connection Example (from Rockwell Catalog):

The DIS safety relay has two dual-channel inputs and four solid-state outputs. Two of the four solid-state outputs are designed to operate with high-capacitance loads. In addition, the DIS safety relay has SWS input and output. The DIS safety relay can be set for automatic or monitored manual reset by adjusting the switch on the front panel. The configuration switch also sets the AND/OR logic that is applied to the inputs.

Configuration Switch Adjustment

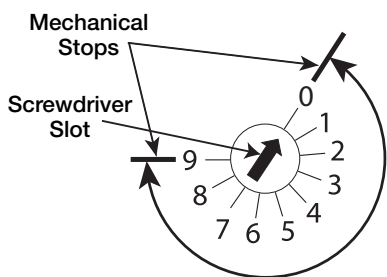

DI and DIS Logic Switch

Position	Reset	Function
0	Not Applicable	Start Configuration
1	Monitored Manual	(IN1 or IN2) or L12
2		(IN1 and IN2) or L12
3		(IN1 and IN2) or L12
4	Automatic/Manual	(IN1 and IN2) and L12
5		(IN1 or IN2) or L12
6		(IN1 and IN2) or L12
7		(IN1 or IN2) and L12
8		(IN1 and IN2) and L12

Terminal	Function
A1	+24V Supply (+10%, -15%)
A2	24V Common
S11	Pulse Test Output for Channel 1
S21	Pulse Test Output for Channel 2
S12	Safety Input for IN1 Channel 1
S22	Safety Input for IN1 Channel 2
S32	Safety Input for IN2 Channel 1
S34	Reset Input
S42	Safety Input for IN2 Channel 2
Y32	Auxiliary Non-Safety Output
L11	Single Wire Safety Output
L12	Single Wire Safety Input
14, 24	Safety Outputs - OSSD
34, 44	Safety Outputs - OSSD for Capacitive Loads

Rockwell 440R-D22S2 Wiring

(Generic Wiring Examples from the Rockwell Catalog)

Example Connections to 2 N.C. Mechanical Contacts

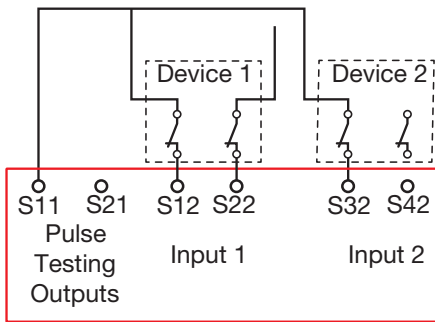

Single Input, Monitored Reset

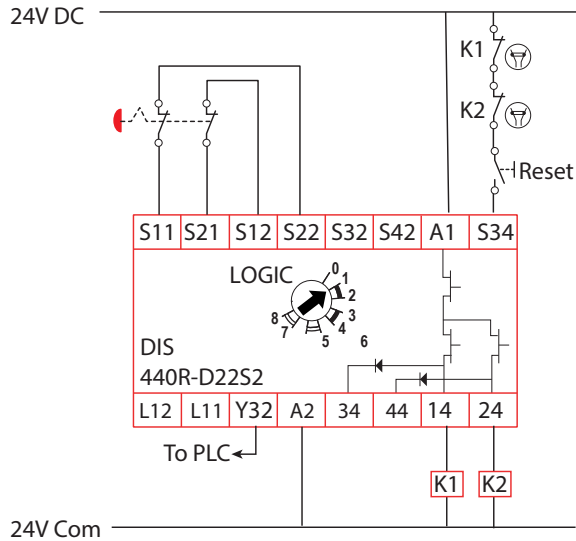

Monitored Reset Connections

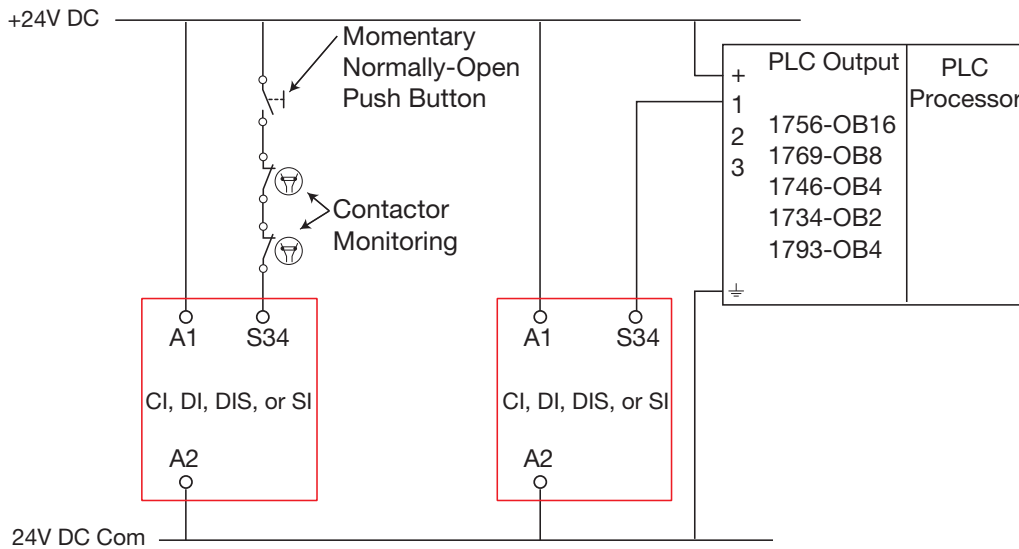

Rockwell 440R-D22S2 Wiring Schematic with PLC to Interface to Safety Exhaust Valve

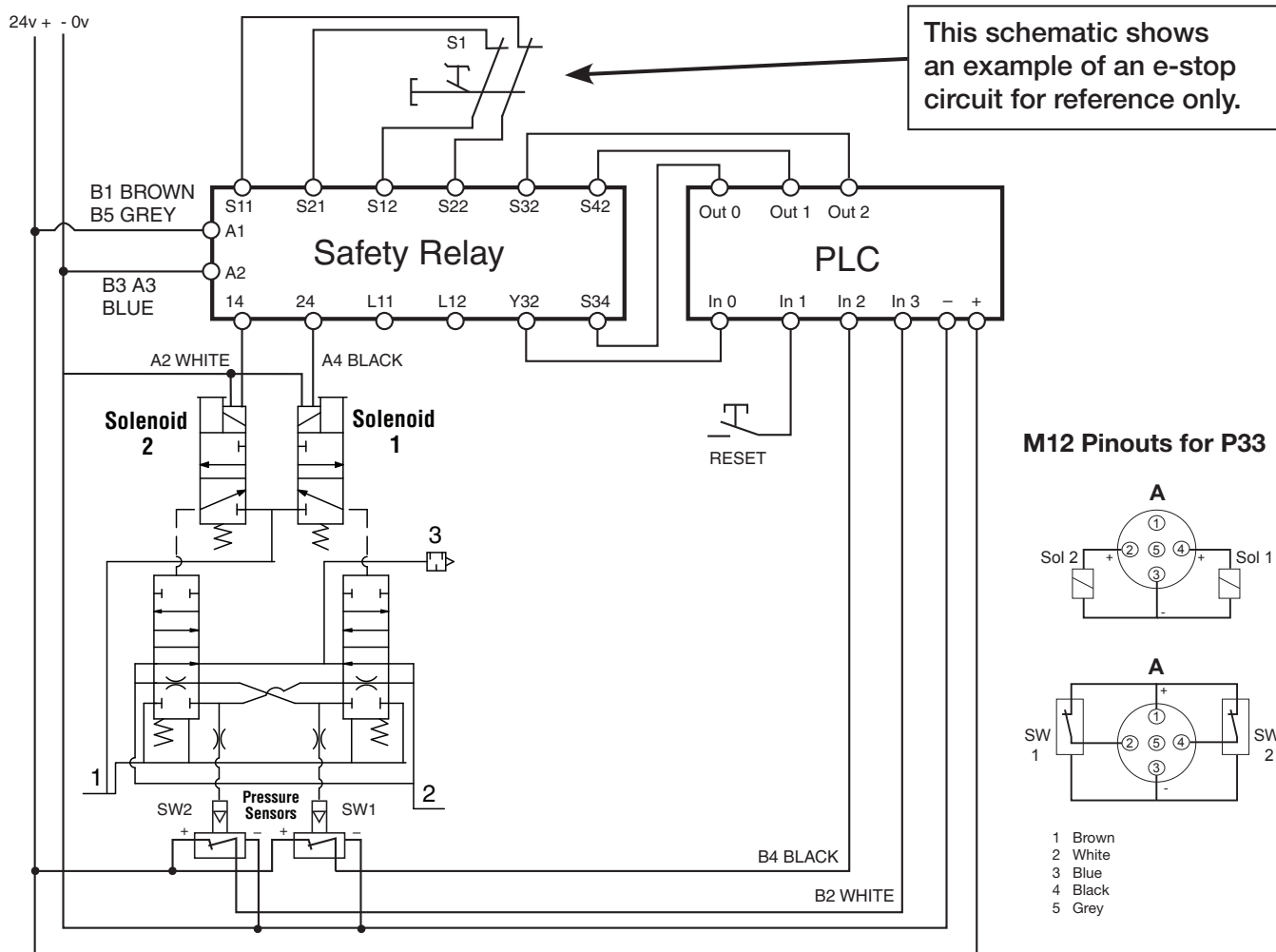

With this schematic it is possible to achieve up to Cat 3 PL d if properly implemented.

External monitoring program for Rockwell 440R-D22S2

- a) sensor error : In2 <> In3 after discrepancy time at 150 ms
- b) feedback error : In2 = In3 = In0 after installation discrepancy time
- c) If error Reset Out 1 & Out 2

Reset error only after maintenance acknowledge

Reset function

- d) IF No "feedback error" & In1
 Out0 = pulse of 2 s

* Programs provided in this integration guide are for reference only. These programs have not been certified or tested unless stated otherwise.

Schmersal SRB-E-204ST



Part Number: SRB-E-20*ST

*=1 or 4 double inputs

- Functional Safety Rating: Cat 4, PL e
- Uses terminals
- Customer will have colored wires
- Can be wired with a PLC for sensor monitoring
- Examples include with and without pin outs and valve schematic

Generic Connection Example for Schmersal SRB-E-201ST (from Schmersal Catalog):

Wiring examples SRB-E-201ST and SRB-E-201LC

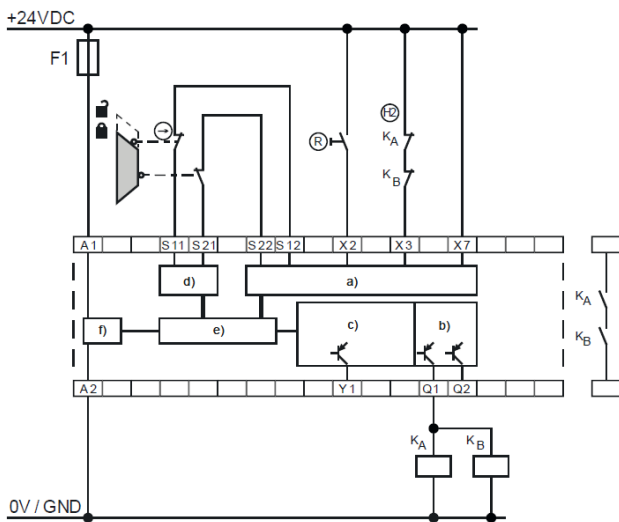

- a) Safety inputs
- b) Safety outputs
- c) Signalling outputs
- d) Clock outputs
- e) Processing
- f) Power

The same schematic is used, but with 4 dual inputs for P/N SRB-E-204ST

Schmersal Wiring Schematic for SRB-E-204ST with PLC to Interface to Safety Exhaust Valve

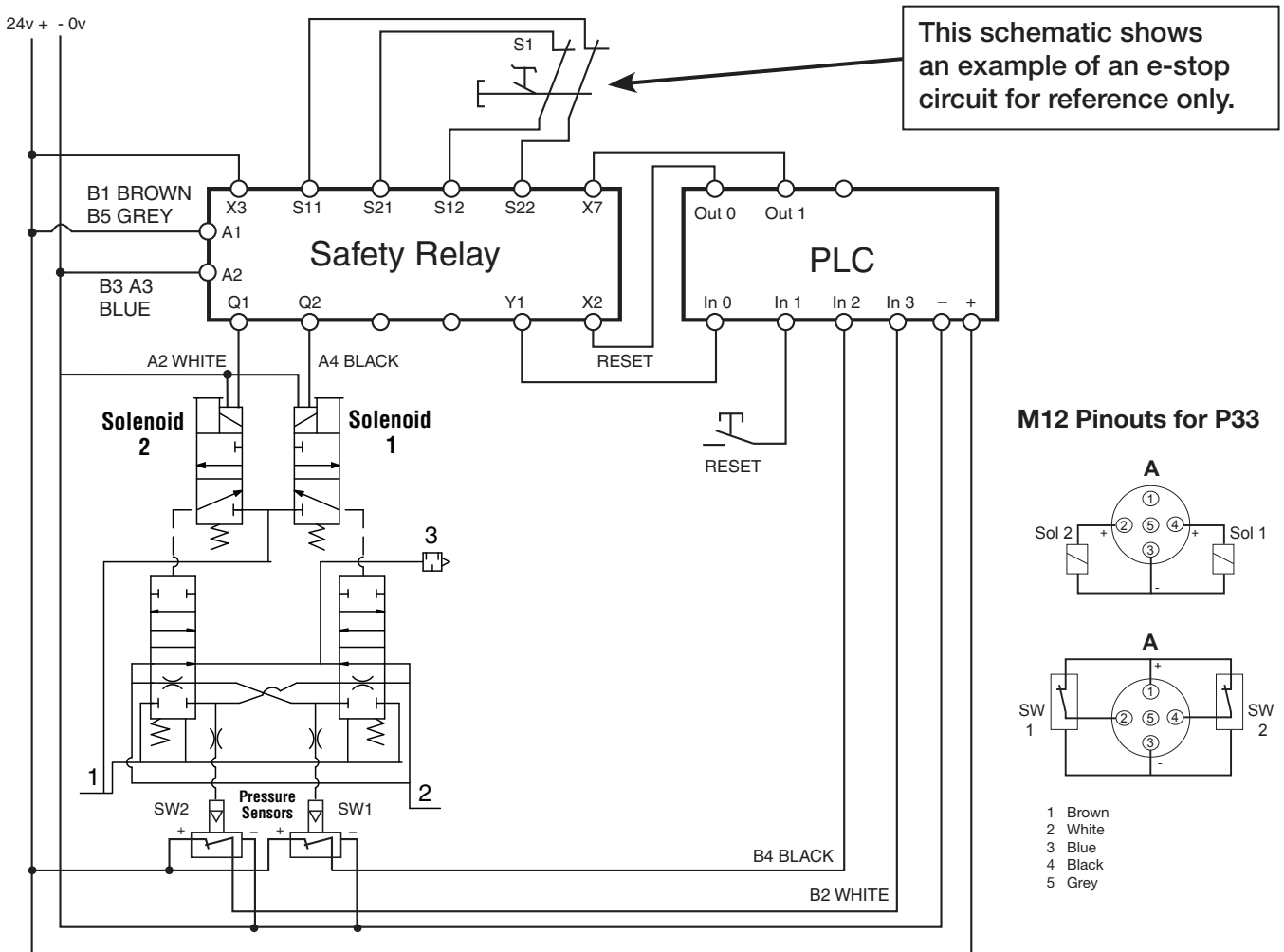

With this schematic it is possible to achieve up to category 3 PL d if properly implemented.

External monitoring program for Schmersal SRB-E-204ST

- a) sensor error : In2 <> In3 after discrepancy time at 150 ms
- b) feedback error : In2 = In3 = In0 after installation discrepancy time
- c) If error Reset Out 1 set error only after maintenance acknowledge

Reset function

- d) IF No “feedback error” & In1
 Out0 = pulse of 2 s

* Programs provided in this integration guide are for reference only. These programs have not been certified or tested unless stated otherwise.

Siemens 3SK1112



Part Number: 3SK1112

Functional Safety Rating: Cat 4, PL e

- Uses terminals
- Customer will have colored wires
- Can be wired with a PLC for sensor monitoring
- Examples include with and without pin outs and valve schematic

Safety Function Information (from Siemens Catalog):

A safety function describes the reaction of a machine/plant to the occurrence of a specific event (e.g. opening of a protective door.) Execution of the safety function(s) is carried out by a safety-related control system. This usually comprises three subsystems, detecting, evaluating and reacting.

Detecting (sensors): Used to detect a safety requirement, eg: Emergency stop or a sensor for monitoring a hazardous area (light array, laser scanner etc) is operated.

Evaluating (safety relay): Detecting a safety requirement and safely initiating the reaction (eg. Switching off the safety related outputs). Monitoring the correct operation of sensors and actuators. Initiating a reaction upon detection of faults.

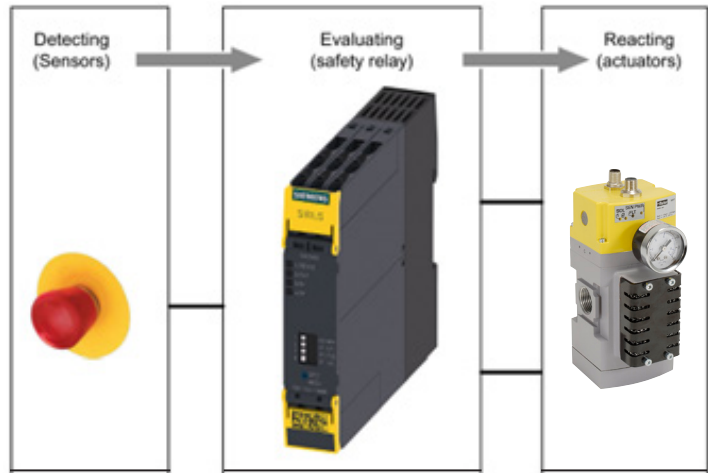

For the 3SKI products described in this guide, this concerns evaluation units for safety functions.

Reacting (actuators): Switching off the hazard by means of downstream actuators.

Generic Siemens Wiring Schematic for 3SK1112 (from Siemens Catalog)

Typical circuit 14: 1NC/1NO sensor, with cross-circuit detection with monitored start

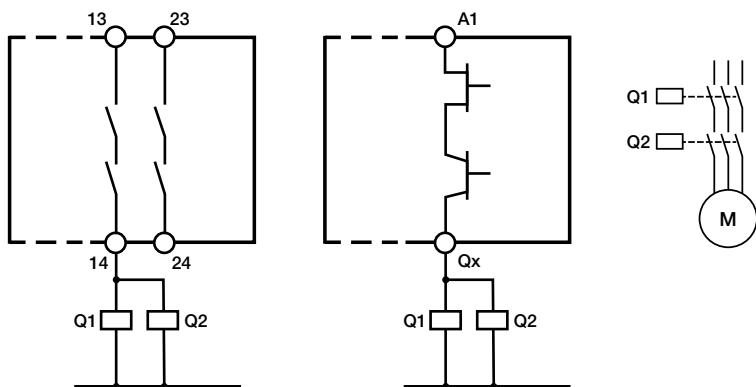
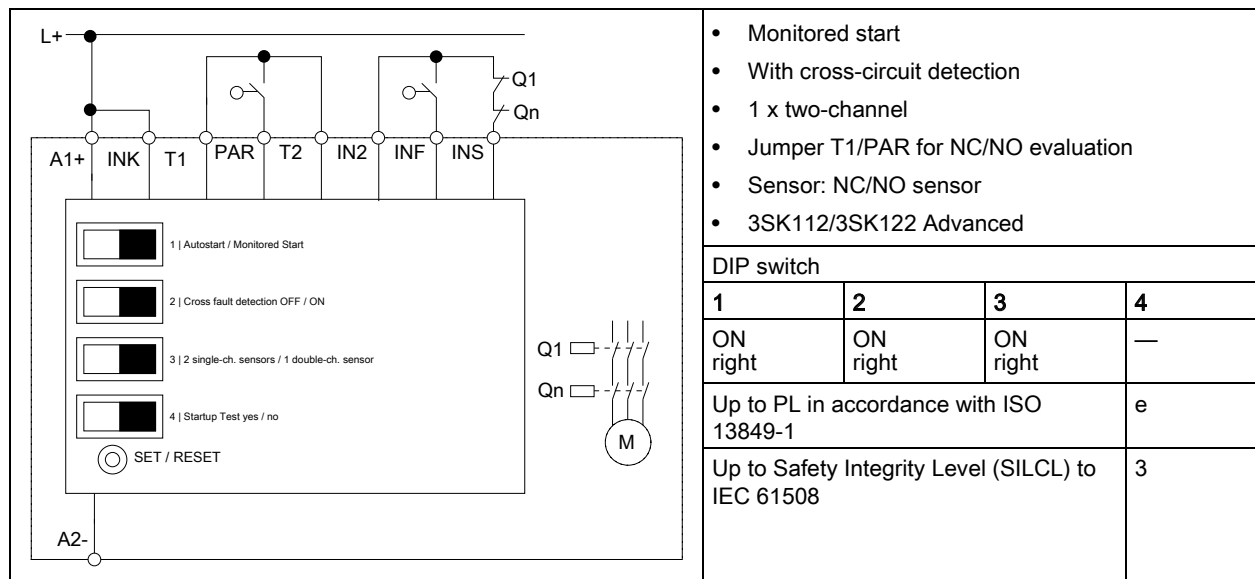

PL e/Cat 4 in accordance with ISO 13849-1 or SILCL 3 in accordance with IEC 62061 with units that have semiconductor outputs, this wiring is only possible from E02/V1.1.0.

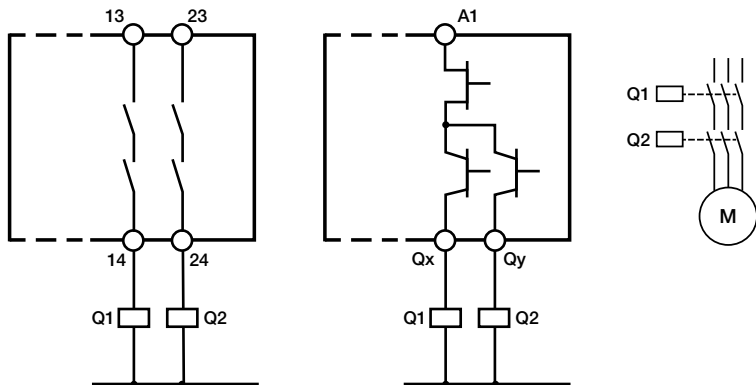

PL e/Cat 4 in accordance with ISO 13849-1 or SILCL 3 in accordance with IEC 62061.

Siemens Wiring Schematic with Dual Output to Interface to Safety Exhaust Valve

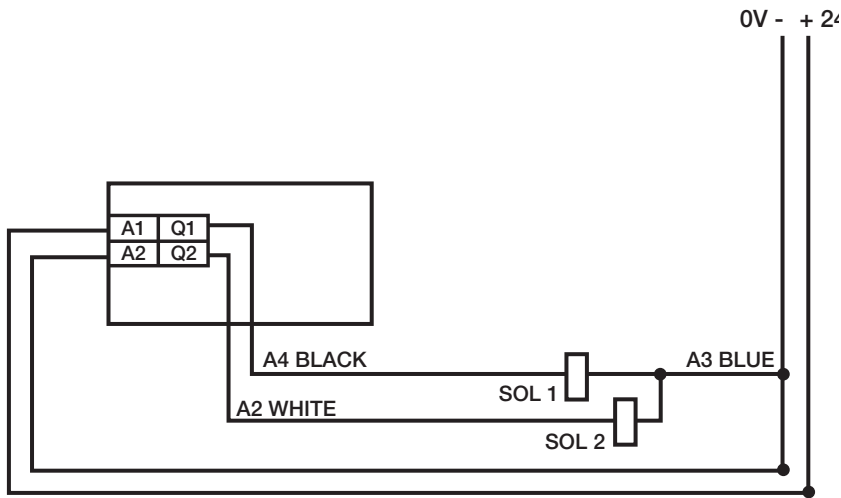

M12 Pinouts for P33

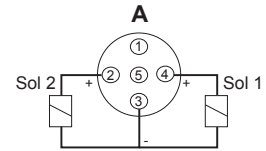

- 1 Brown
- 2 White
- 3 Blue
- 4 Black
- 5 Grey

Siemens Wiring Schematic with One Safe Output to Interface to Safety Exhaust Valve

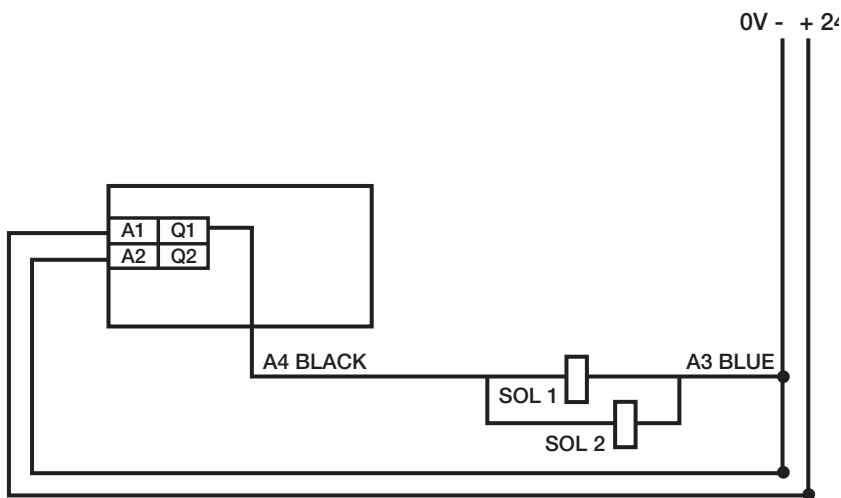

M12 Pinouts for P33

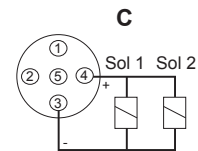

- 1 Brown
- 2 White
- 3 Blue
- 4 Black
- 5 Grey

Siemens Wiring Schematic for 3SK1112-1BB40 with PLC to Interface to Safety Exhaust Valve

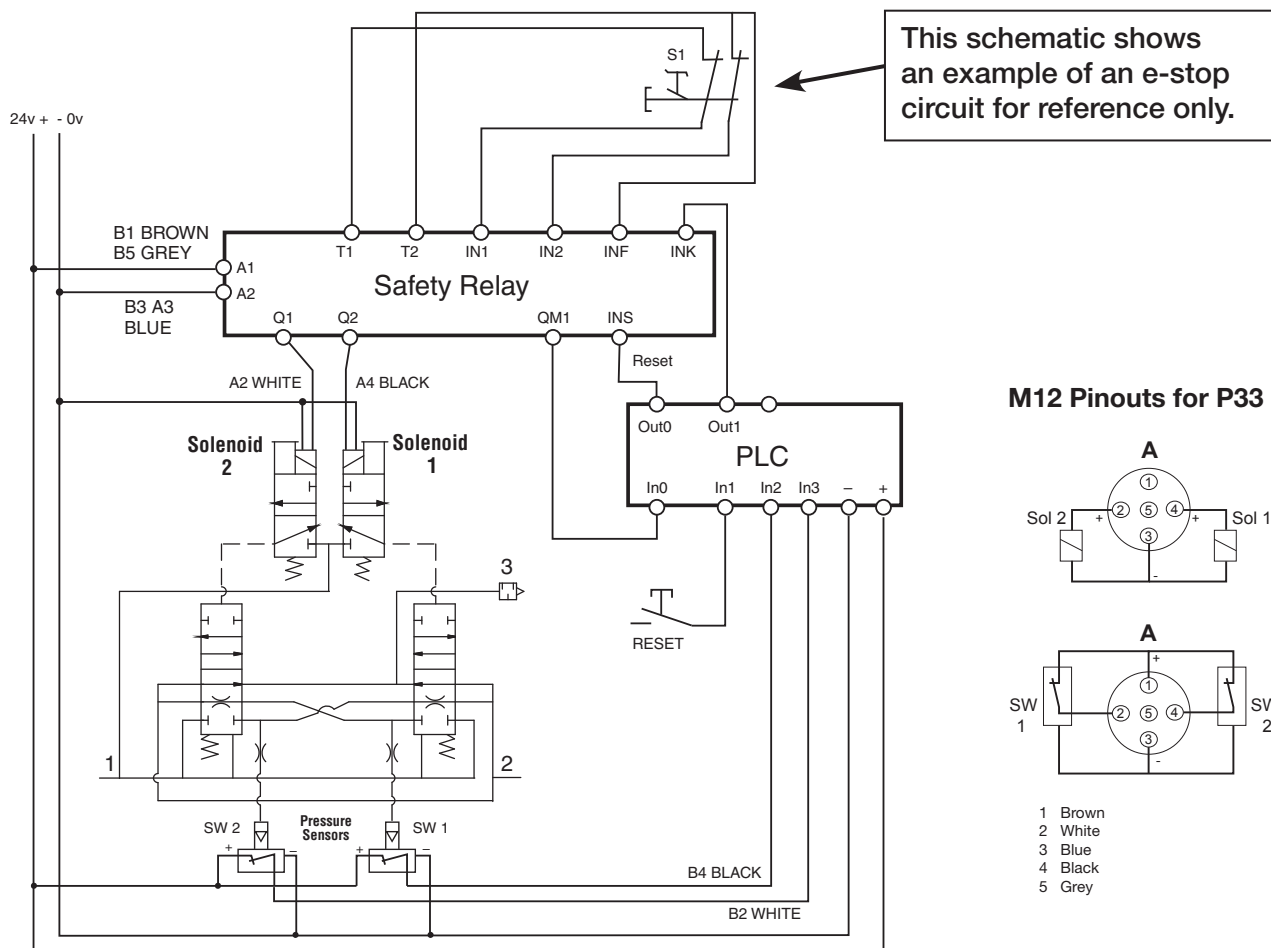

With this schematic it is possible to achieve up to category 3 PL d if properly implemented.

External monitoring program for Siemens 3SK1112

- a) sensor_error : In2 <> In3 after discrepancy time at 150 ms
- b) feedback error : In2 = In3 = In0 after installation discrepancy time
- c) If error Reset Out 1 set error only after maintenance acknowledge

Reset function

- d) IF No “feedback error” & In1
 Out0 = pulse of 2 s

* Programs provided in this integration guide are for reference only. These programs have not been certified or tested unless stated otherwise.

Integration Guide (Programmable Safe Relay) (for applications requiring Cat 4 PL e)

Omron G9SP-N10S



Part Number: G9SP-N10S
 Functional Safety Rating: Cat 4, PL e

- Uses terminal wiring
- Test pulsing compatibility
- 10 PNP Safe Inputs
- 4 PNP Sourcing Safe Outputs
- 4 PNP Sourcing Standard Outputs
- 4 Unique Test Pulses

Omron GG9SP-N10S - No Test Pulse on Sensors

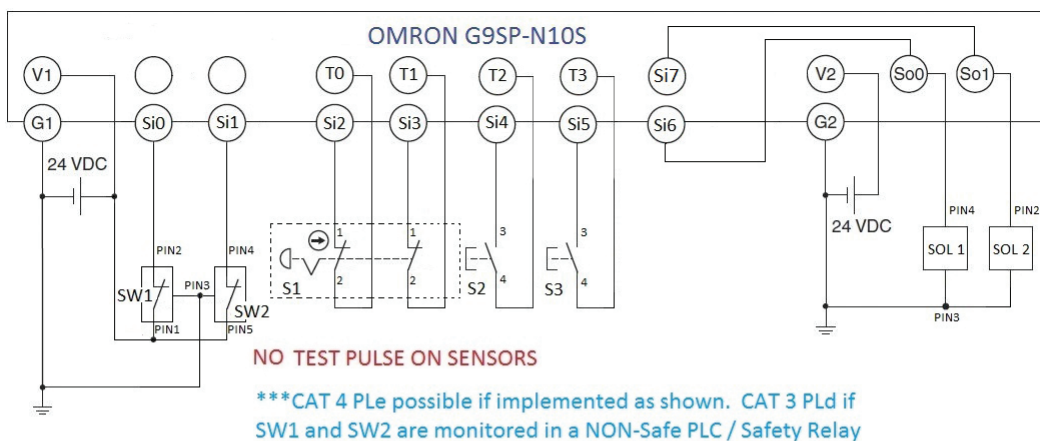

LEGEND	
S1	E-STOP
S2	RESET PB
S3	ENABLE PB
SW1	PRESSURE SENSOR 1 P33T
SW2	PRESSURE SENSOR 2 P33T
SOL 1	SOLENOID 1 P33T
SOL 2	SOLENOID 2 P33T

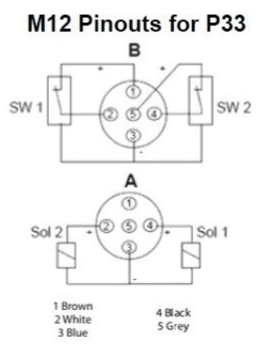

Safety I/O Terminal Settings

Terminal	Name of settings	I/O Comment	Test Source
Si0	Single Safety PNP Output	PS1	
Si1	Single Safety PNP Output	PS2	
Si2	Emergency Stop Switch(2NC)	E-STOP CH1	T0
Si3		E-STOP CH2	T1
Si4	Reset Switch	RESET PB	T2
Si5	Reset Switch	ENABLE SOL PB	T3
Si6	Single Safety PNP Output	SOL 1 FDBK	
Si7	Single Safety PNP Output	SOL 2 FDBK	
Si8			
Si9			

Safety I/O Terminal Settings

Terminal	Name of settings	I/O Comment
So0	Dual Safety PNP Outputs w/ Pulse Test	SOL 1
So1		SOL 2
So2		
So3		

Omron G9SP-N10S - Test Pulse on Sensors

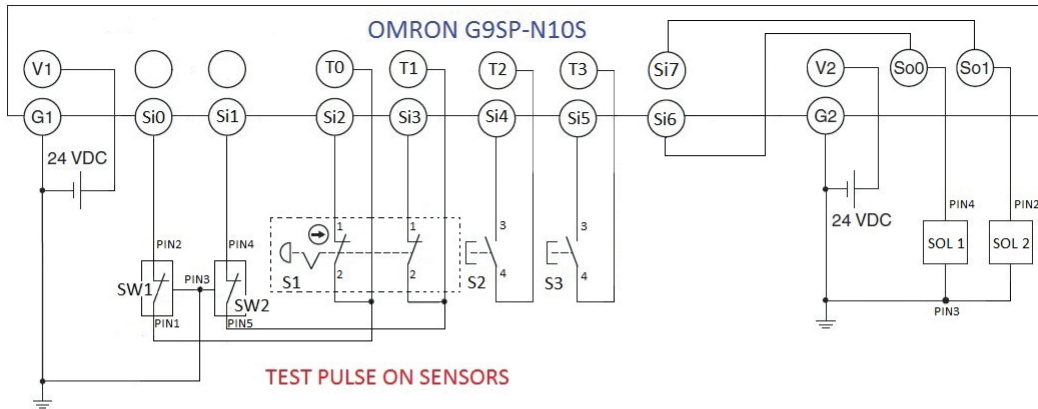

***CAT 4 PLc possible if implemented as shown. CAT 3 PLc if SW1 and SW2 are monitored in a NON-Safe PLC / Safety Relay

LEGEND

- S1 - E-STOP
- S2 - RESET PB
- S3 - ENABLE PB
- SW1 - PRESSURE SENSOR 1 P33T
- SW2 - PRESSURE SENSOR 2 P33T
- SOL 1 - SOLENOID 1 P33T
- SOL 2 - SOLENOID 2 P33T

M12 Pinouts for P33

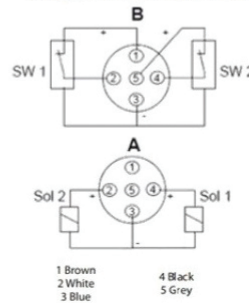

Safety I/O Terminal Settings

Terminal	Name of settings	I/O Comment	Test Source
Si0	Safety Switch(1NC)	PS1	T0
Si1	Safety Switch(1NC)	PS2	T1
Si2	Emergency Stop Switch(2NC)	E-STOP CH1	T0
Si3	Emergency Stop Switch(2NC)	E-STOP CH2	T1
Si4	Reset Switch	RESET PB	T2
Si5	Reset Switch	ENABLE SOL PB	T3
Si6	Single Safety PNP Output	SOL 1 FDBK	
Si7	Single Safety PNP Output	SOL 2 FDBK	
Si8			
Si9			

Safety I/O Terminal Settings

Terminal	Name of settings	I/O Comment
So0	Dual Safety PNP Outputs w/ Pulse Test	SOL 1
So1		SOL 2
So2		
So3		

Omron G9SP-N10S

External Monitoring program for Omron G9SP-N10S

- a) If $Si0 = Si1 = 1$ AND safety hardwire circuit in Active state AND no faults present THEN SET $So0 = So1 = 1$ when commanded
- b) Sensor discrepancy error: $Si0 \neq Si1$ (max. discrepancy time = 150 msec)
- c) Loss of pressure error: $So0 = So1 = 1$ AND $Si0 = Si1 = 0$ followed by $Si0 = 1$ OR $Si1 = 1$ AND $So0 = So1 = 1$
- d) System pressure error: $So0 = So1 = 1$ AND $Si0 = Si1 = 1$ for x amount of time (where x is system pressurization time dependent on volume) Default 3 secs.
- e) IF sensor discrepancy error OR loss of pressure error OR system pressure error THEN reset $So0 = So1 = 0$

Errors must be reset only after maintenance acknowledgement

* Programs provided in this integration guide are for reference only. These programs have not been certified or tested unless stated otherwise.

Pilz PNOZ



Part Number: 772100 Pnoz m B0
 Functional Safety Rating: Cat 4, PL e

- Uses terminals
- Customer will have colored wires
- Can be wired with and without test pulses on the sensors
- Examples include with and without pin outs and valve schematic

Generic Connection Example (from Pilz Catalog):

Dual-channel E-STOP and safety gate wiring, monitored start and feedback loop.

Block diagram

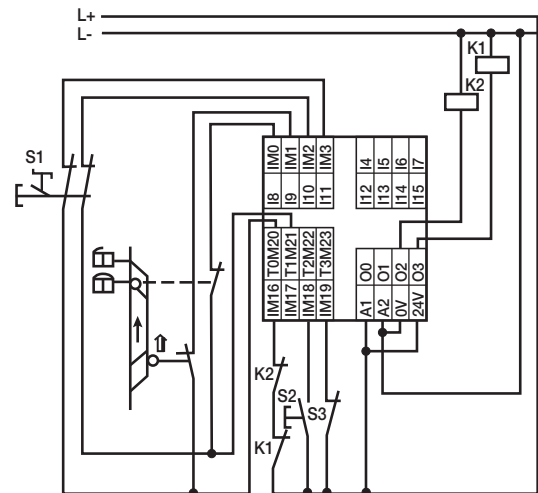
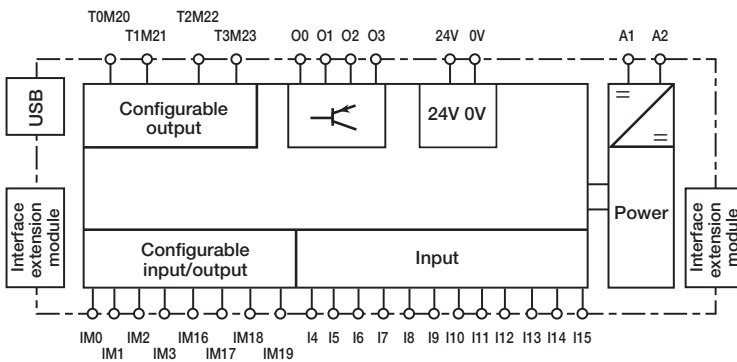

5-Pin

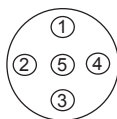

- 1 Brown
- 2 White
- 3 Blue
- 4 Black
- 5 Grey

Pilz Wiring Schematic (without sensor test pulse) to Interface to Safety Exhaust Valve

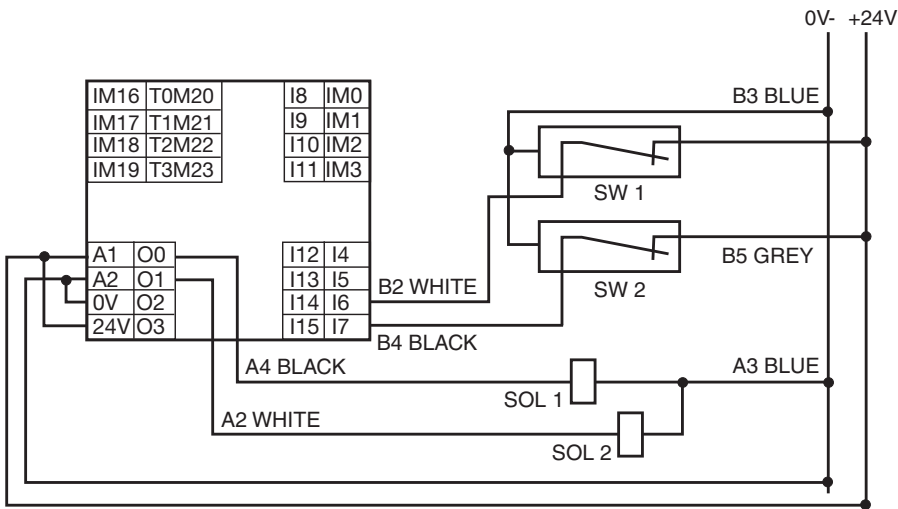

M12 Pinouts for P33

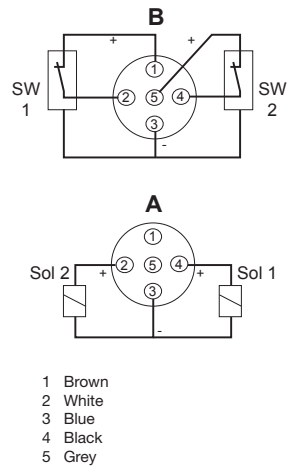

With this schematic it is possible to achieve up to category 4 PL e if properly implemented.

Pilz Wiring Schematic (with sensor test pulse) to interface to Safety Exhaust Valve

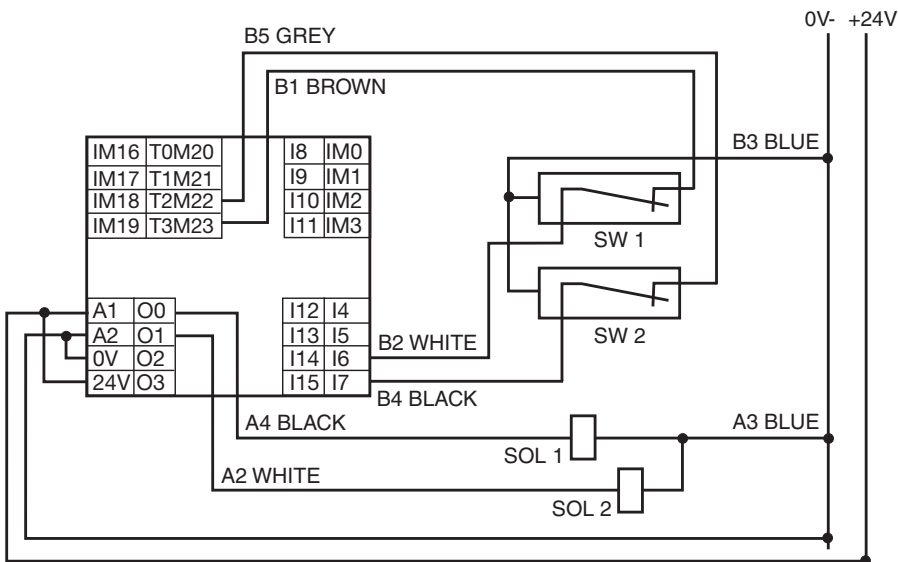

M12 Pinouts for P33

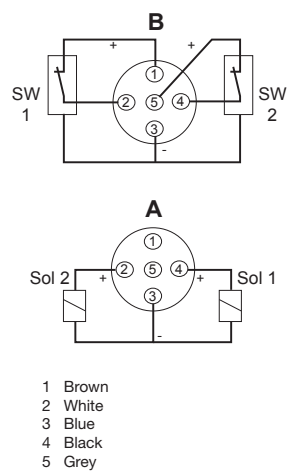

With this schematic it is possible to achieve up to category 4 PL e if properly implemented.

Rockwell 440C-CR30



Part Number: 440C-CR30-22BBB
Functional Safety Rating: Cat 4, PL e

- Software configured safety relay
- 22 safety I/O with embedded serial port
- USB programming port
- 2 plug-in slots
- 24 V DC

Generic Connection Example (from Rockwell Catalog):

Input Devices with Mechanical Contacts

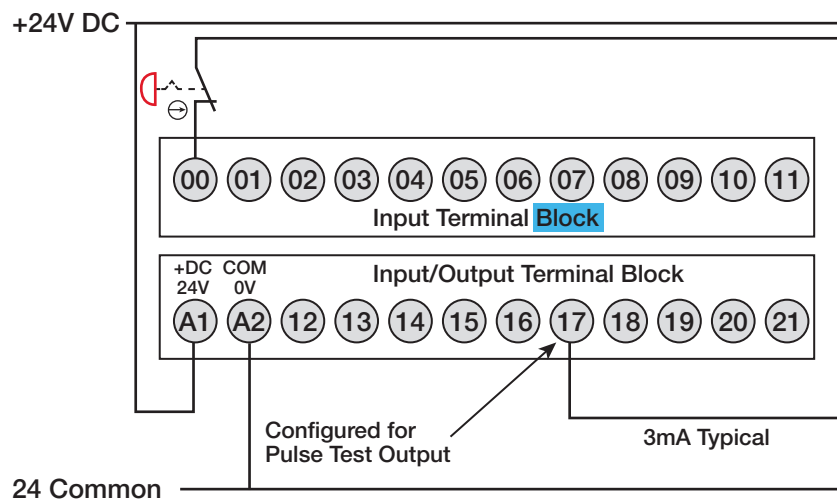

Generic Rockwell Wiring Schematic for 440C-CR30 (from the Rockwell Catalog)

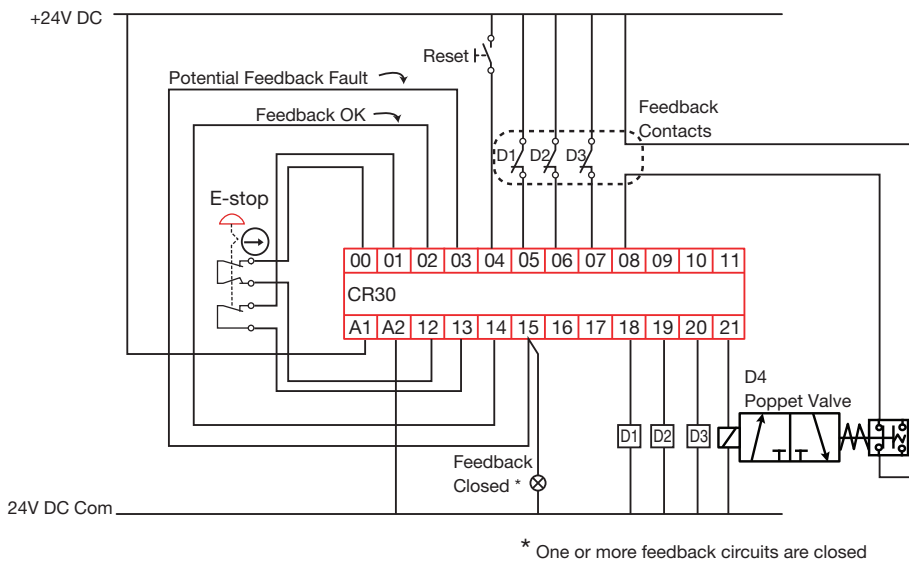

The feedback indicator is ON when the E-stop is pressed and the outputs (D1...D4) are OFF. When the E-stop is released and the reset button is pressed, this indicator turns OFF unless one or more of the feedback contacts are shorted.

Circuit Status

The E-stop is released and all output devices D1...D4 are OFF. The Feedback Closed indicator is ON.

Operational Sequence

1. Press the Reset button.
 All four output devices D1...D4 turn ON and the Feedback Closed indicator turns OFF.
2. Press the E-stop button.
 All four output devices D1...D4 turn OFF and the Feedback Closed indicator turns ON.

With a short circuit across one of the output device contacts:

1. Press the Reset button.
 All four output devices D1...D4 turn ON and the Feedback Closed indicator remains ON. After approximately 50 ms, the output devices D1...D4 turn OFF and the Feedback Closed indicator remains ON.

Each time the reset button is pressed, the output turns ON momentarily and then turns OFF. The CR30 Safety relay detects the short circuit with the XOR logic in the LL2A function block. This block allows either the Feedback_OK or Feedback_Fault to turn on the output devices, but not both signals.

Rockwell Wiring Schematic (without sensor test pulse) to Interface to Safety Exhaust Valve

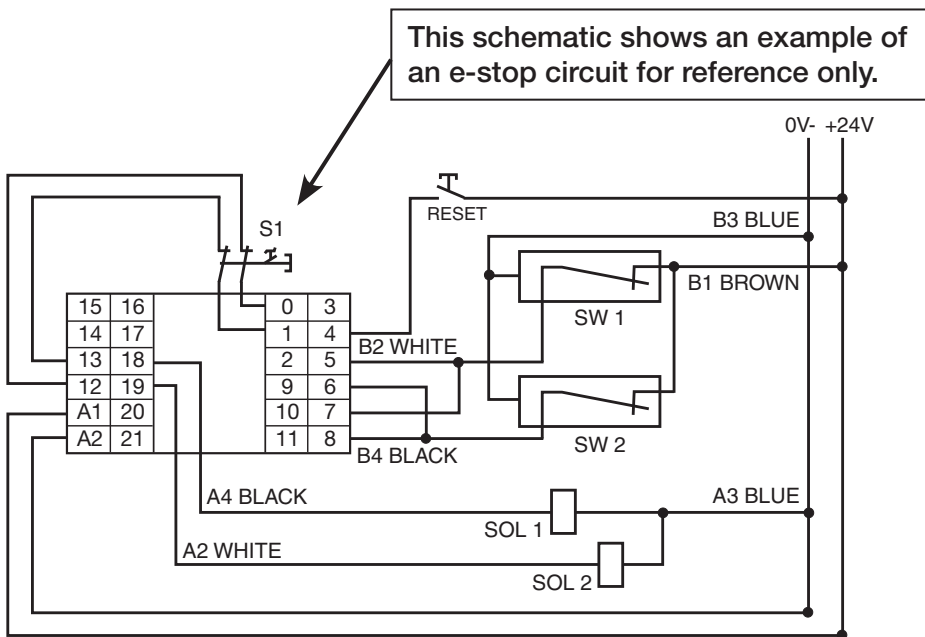

This schematic shows an example of an e-stop circuit for reference only.

M12 Pinouts for P33

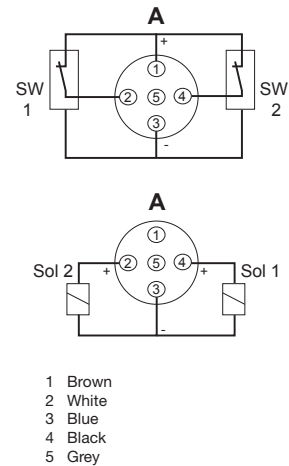

With this schematic it is possible to achieve up to category 4 PL e if properly implemented.

Rockwell Wiring Schematic (with sensor test pulse) to Interface to Safety Exhaust Valve

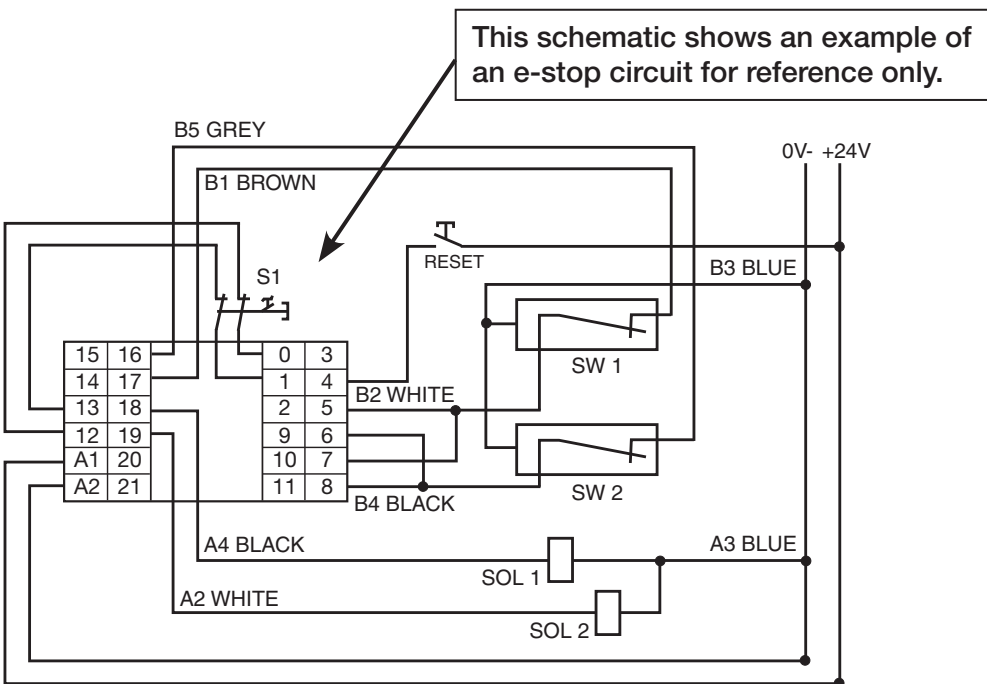

This schematic shows an example of an e-stop circuit for reference only.

M12 Pinouts for P33

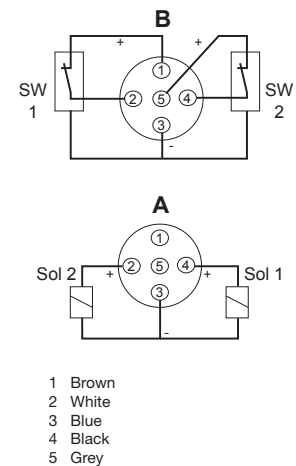

With this schematic it is possible to achieve up to category 4 PL e if properly implemented

Rockwell Wiring Schematic (without sensor test pulse) to Interface to Safety Exhaust Valve

This schematic shows an example of an e-stop circuit for reference only.

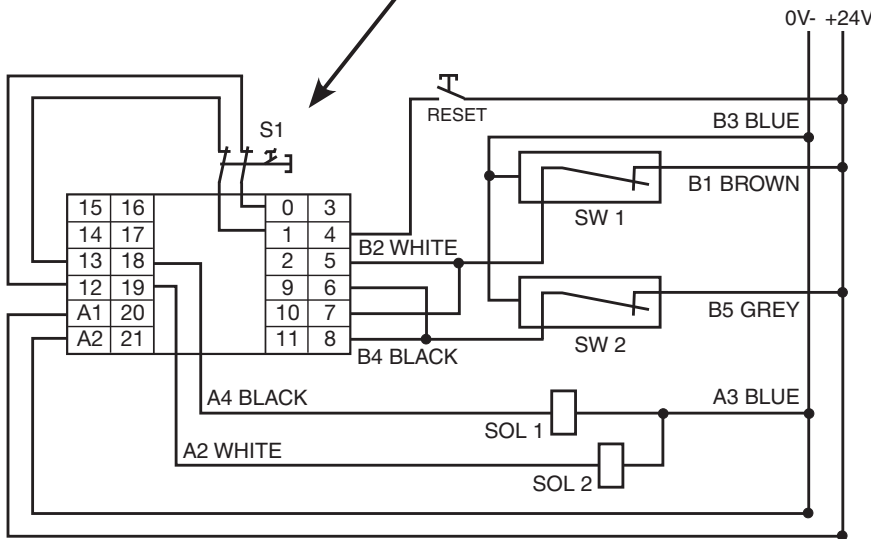

M12 Pinouts for P33

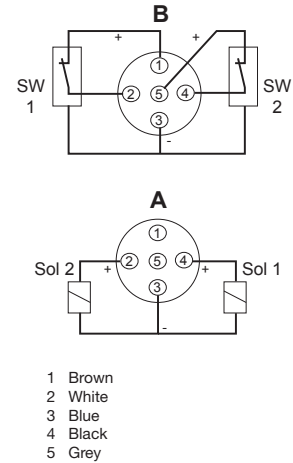

With this schematic it is possible to achieve up to category 4 PL e if properly implemented.

External monitoring program for Rockwell 440C-CR30

- a) If I.5 = I.6 = I.0 = I.1 = 1 AND no faults present THEN SET O.18 = O.19 = 1 when commanded
 - b) Sensor discrepancy error: I.7 <> I.8 (max. discrepancy time = 150 msec)
 - c) Loss of pressure error: O.18 = O.19 = 1 AND I.7 = I.8 = 0 followed by I.5 = 1 OR I.6 = 1 AND O.18 = O.19 = 1
 - d) System pressure error: O.18 = O.19 = 1 AND I.7 = I.8 = 1 for x amount of time (x is system pressurization time dependent on volume) Default 3 secs.
 - e) IF sensor discrepancy error OR loss of pressure error OR system pressure error THEN reset O.18 = O.19 = 0
- Errors must be reset only after maintenance acknowledgement

* Programs provided in this integration guide are for reference only. These programs have not been certified or tested unless stated otherwise.

Integration Guide (Safe PLC I/O) (for applications requiring Cat 4 PL e)

Molex Brad Harsh IO TCDEC-8B4P and TCDEC-8B4B



Part Number: TCDEC-8B4P

- 12 PNP Safe Inputs
- 4 PNP Sourcing Safe Outputs

Part Number: TCDEC-8B4B

- 12 PNP Safe Inputs
- 2 Bipolar Safe Outputs

Functional Safety Rating: Cat 4, PL e

- Uses M12 connections
- Test pulsing configurable on inputs
- EtherNet/IP CIP Safety Adapter

Molex Brad Harsh IO Pinouts

A		B	
POWER IN MALE 7/8" 4PIN	POWER OUT FEMALE 7/8" 4PIN	POWER IN MALE 7/8" 5PIN	POWER OUT FEMALE 7/8" 5PIN
<p>WIRING INFORMATION P1 - +24 VDC (Outputs Power) P2 - +24 VDC (Module & Inputs Power) P3 - 0 V (Ground Module & Inputs Power) P4 - 0 V (Outputs Power)</p>	<p>WIRING INFORMATION P1 - 0 V (Outputs Power) P2 - 0 V (Module & Inputs Power) P3 - PE (Protected Earth) P4 - +24 VDC (Module and Inputs Power) P5 - +24 VDC (Outputs Power)</p>	<p>8x FEMALE M12 5P A-CODE</p> <p>WIRING INFORMATION P1 - +24 VDC (W/or W/O Test Pulse A) P2 - Save Input (even) P3 - 0V (Input Power) P4 - Save Input (odd) P5 - +24 VDC (W/or W/O Test Pulse B)</p>	<p>8x FEMALE M12 5P A-CODE</p> <p>WIRING INFORMATION P1 - 24V DC (UL) P2 - Safe Output (even) P3 - 0V (Output Power) P4 - Safe Output (odd) P5 - 0V (Output Power)</p>

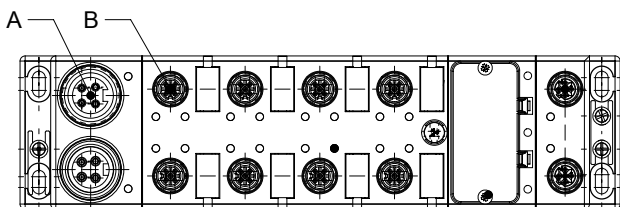

TCDEC-8B4P Wiring Diagram

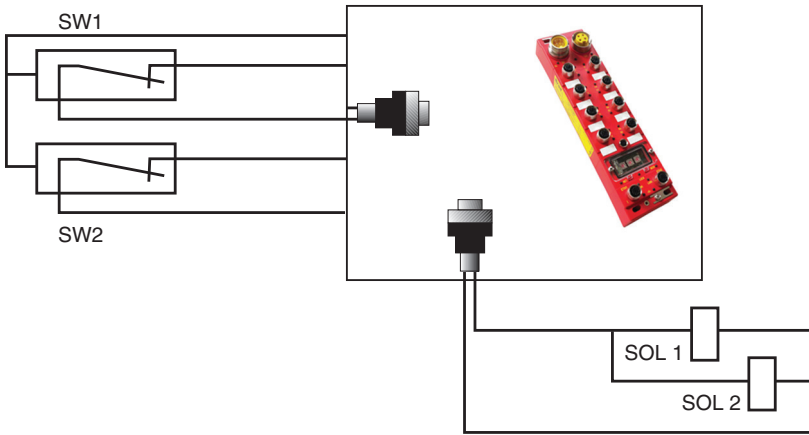

M12 Pinouts for P33

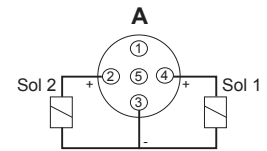
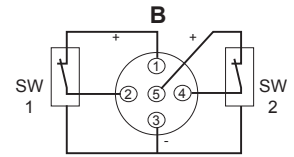

- 1 Brown
- 2 White
- 3 Blue
- 4 Black
- 5 Grey

With this schematic it is possible to achieve up to category 4 PL e if properly implemented.

TCDEC-8B4B Wiring Diagram

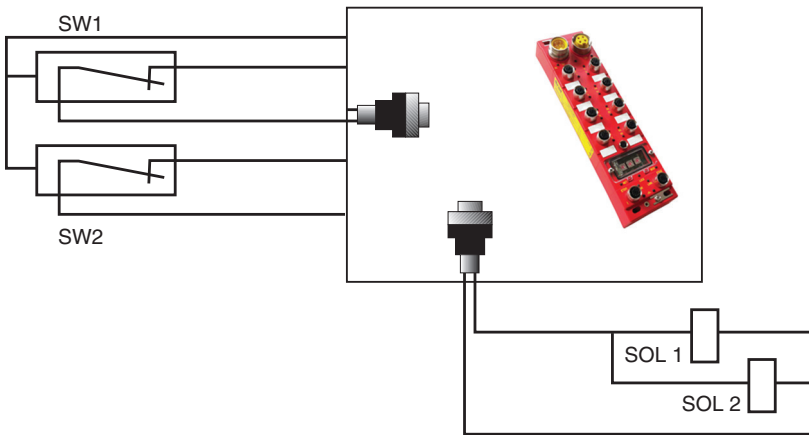

M12 Pinouts for P33

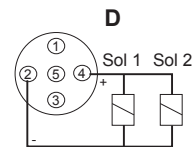
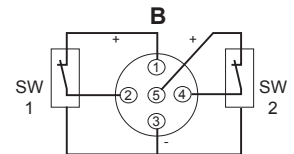

- 1 Brown
- 2 White
- 3 Blue
- 4 Black
- 5 Grey

With this schematic it is possible to achieve up to category 4 PL e if properly implemented.

External monitoring program for Molex Brad Harsh IO TCDEC-8B4P and TCDEC-8B4B

- a) If $I0 = I1 = 1$ AND safety hardwire circuit in Active state AND no faults present THEN SET $O0 = O1 = 1$ when commanded
- b) Sensor discrepancy error: $I0 <> I1$ (max. discrepancy time = 150 msec)
- c) Loss of pressure error: $O0 = O1 = 1$ AND $I0 = I1 = 0$
followed by $I0 = 1$ OR $I1 = 1$ AND $O0 = O1 = 1$
- d) System pressure error: $O0 = O1 = 1$ AND $I0 = I1 = 1$ for x amount of time (where x is system pressurization time dependent on volume) Default 3 secs.
- e) IF sensor discrepancy error OR loss of pressure error OR system pressure error THEN reset $O0 = O1 = 0$

Errors must be reset only after maintenance acknowledgement

* Programs provided in this integration guide are for reference only. These programs have not been certified or tested unless stated otherwise.

Rockwell 1732ES-IB8XOB8



Part Number: 1732ES-IB8XOB8
 Functional Safety Rating: Cat 4, PL e

- Uses M12
- Direct M12 cable
- Central or IO modules
- Dual output

The Guard I/O modules implement the CIP Safety™ protocol extensions over EtherNet/IP networks and provide various features for a safety system.

Use the modules to construct a safety-control network system that meets the following requirements, up to and including:

- Safety Integrity Level Claim Limit 3 (SIL CL 3), as defined in IEC 61508
- Category 4 (CAT. 4), Performance Level e (PLe), as defined in ISO 13849-1

Generic Rockwell 1732ES-IB8XOB8 Wiring (from Rockwell Catalog)

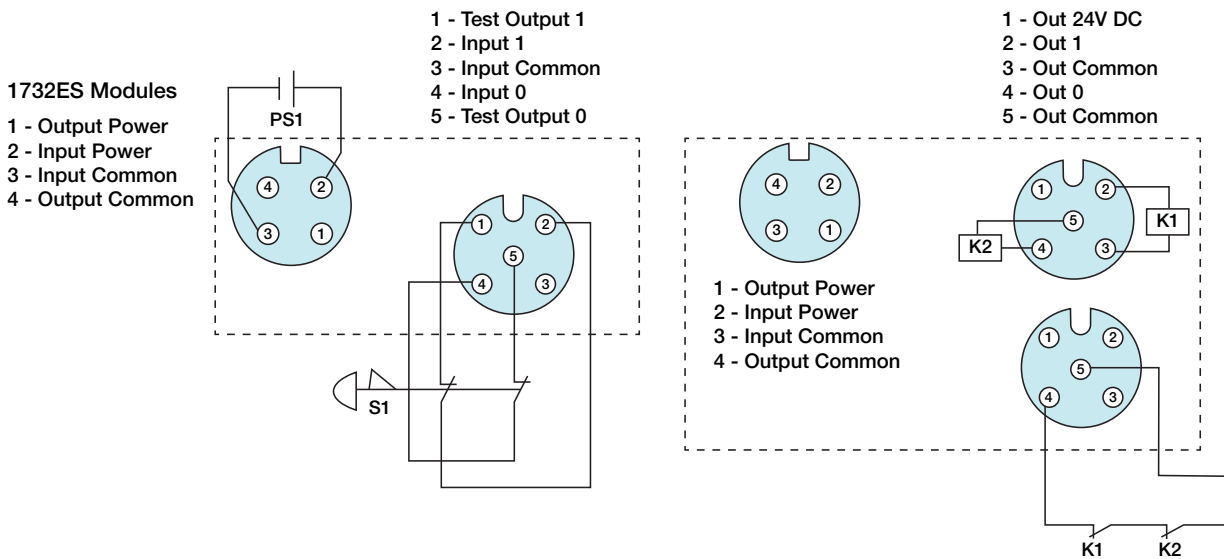

Rockwell 1732ES-IB8X0B8 Wiring Schematic (from Rockwell Catalog) to Interface to Safety Exhaust Valve

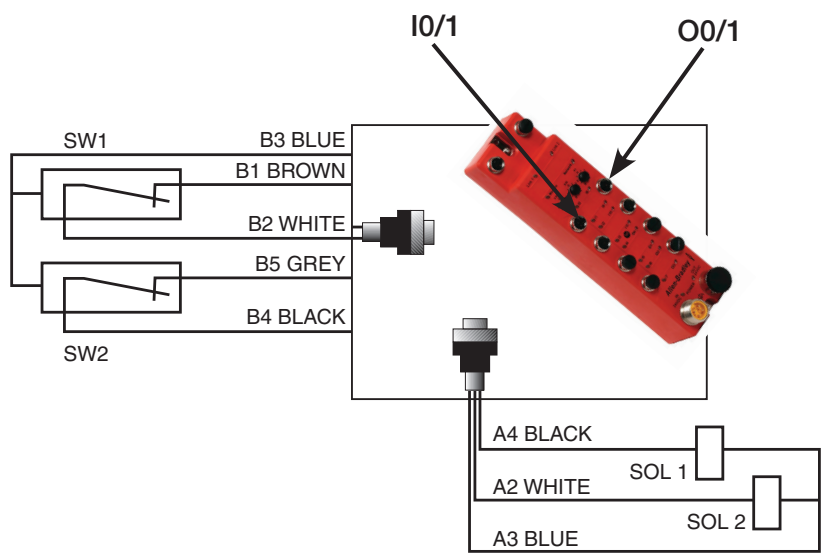

M12 Pinouts for P33

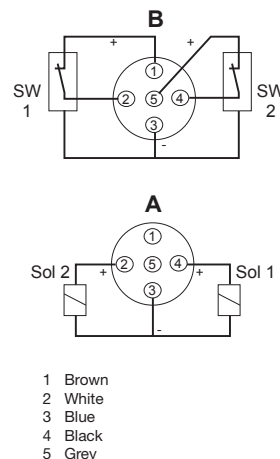

With this schematic it is possible to achieve up to Cat 4 PL e if properly implemented.

External monitoring program for Rockwell 1732ES-IB8XOB8

- a) If $I0 = I1 = 1$ AND safety hardwire circuit in Active state AND no faults present THEN SET $O0 = O1 = 1$ when commanded
 - b) Sensor discrepancy error: $I0 \neq I1$ (max. discrepancy time = 150 msec)
 - c) Loss of pressure error: $O0 = O1 = 1$ AND $I0 = I1 = 0$ followed by $I0 = 1$ OR $I1 = 1$ AND $O0 = O1 = 1$
 - d) System pressure error: $O0 = O1 = 1$ AND $I0 = I1 = 1$ for x amount of time (where x is system pressurization time dependent on volume) Default 3 secs.
 - e) IF sensor discrepancy error OR loss of pressure error OR system pressure error THEN reset $O0 = O1 = 0$
- Errors must be reset only after maintenance acknowledgement

* Programs provided in this integration guide are for reference only. These programs have not been certified or tested unless stated otherwise.

Rockwell 1732ES-IB8XOBV4

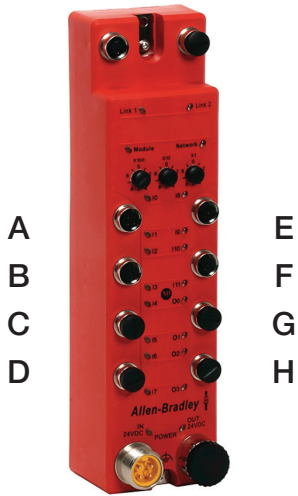

Part Number: 1732ES-IB8XOBV4
 Functional Safety Rating: Cat 4, PL e

- Uses M12
- Direct M12 cable
- Central or IO modules
- Safe output

The Guard I/O modules implement the CIP Safety™ protocol extensions over EtherNet/IP networks and provide various features for a safety system.

Use the modules to construct a safety-control network system that meets the following requirements, up to and including:

- Safety Integrity Level Claim Limit 3 (SIL CL 3), as defined in IEC 61508
- Category 4 (CAT. 4), Performance Level e (PLe), as defined in ISO 13849-1

Generic Rockwell 1732ES-IB8XOBV4 Wiring (from Rockwell Catalog)

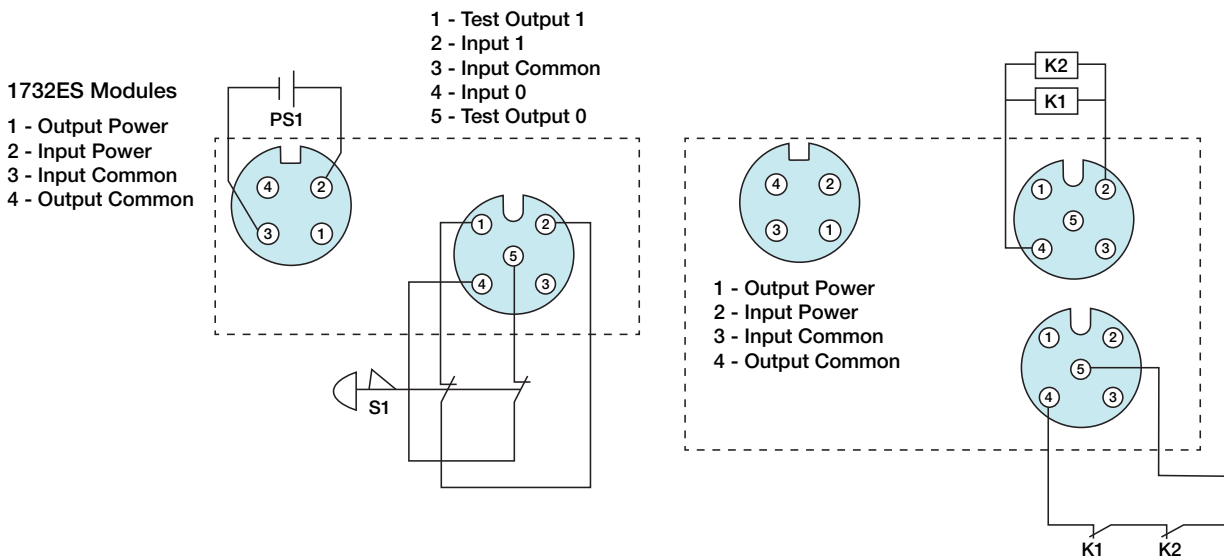

Rockwell 1732ES-IB8X0BV4 Wiring Schematic (from Rockwell Catalog) to Interface to Safety Exhaust Valve

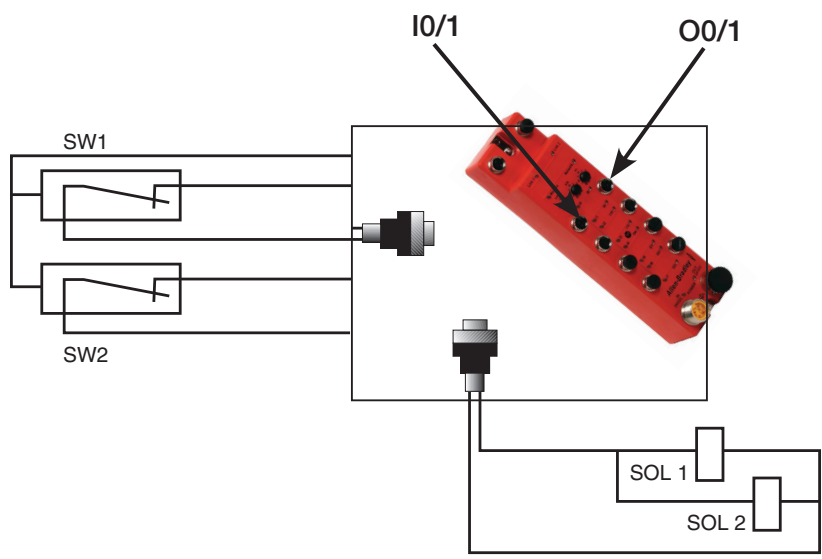

M12 Pinouts for P33

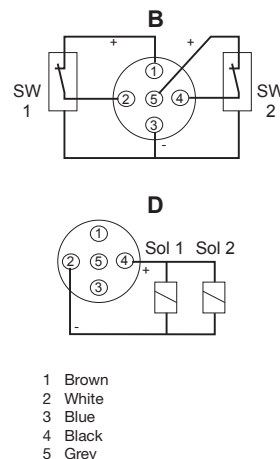

With this schematic it is possible to achieve up to Cat 4 PL e if properly implemented.

External monitoring program for Rockwell 1732ES-IB8XOBV4

- a) If I0 = I1 = 1 AND safety hardwire circuit in Active state AND no faults present THEN SET O0 = O1 = 1 when commanded
 - b) Sensor discrepancy error: I0 <> I1 (max. discrepancy time = 150 msec)
 - c) Loss of pressure error: O0 = O1 = 1 AND I0 = I1 = 0 followed by I0 = 1 OR I1 = 1 AND O0 = O1 = 1
 - d) System pressure error: O0 = O1 = 1 AND I0 = I1 = 1 for x amount of time (where x is system pressurization time dependent on volume) Default 3 secs.
 - e) IF sensor discrepancy error OR loss of pressure error OR system pressure error THEN reset O0 = O1 = 0
- Errors must be reset only after maintenance acknowledgement

* Programs provided in this integration guide are for reference only. These programs have not been certified or tested unless stated otherwise.

Rockwell 1734-OB8S/1734-IB8S

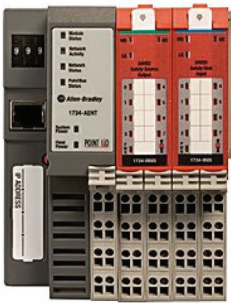

Part Number: 1734-OB8S/1734-IB8S

Functional Safety Rating: Cat 4, PL e

- Uses terminals
- Fits into the standard POINT I/O™ system
- Communicates by using the CIP™ Safety protocol over EtherNet/IP™ for GuardLogix™ controllers
- Supports 24V DC I/O circuits
- Can be pulse-tested to detect wiring short circuits to 24VDC

Rockwell Point Guard I/O 1734-OB8S

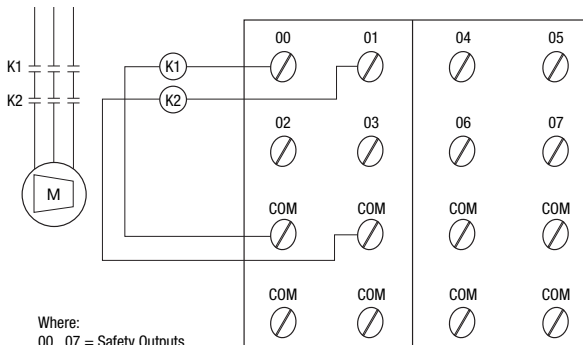

Controller Configuration	Parameter Name	Configuration Setting
Safety Output 0	Safety Output 0 Point Mode	Safety Pulse Test
	Point Operation Mode	Dual-channel
Safety Output 1	Safety Output 1 Point Mode	Safety Pulse Test

Rockwell Point Guard I/O 1734-IB8S

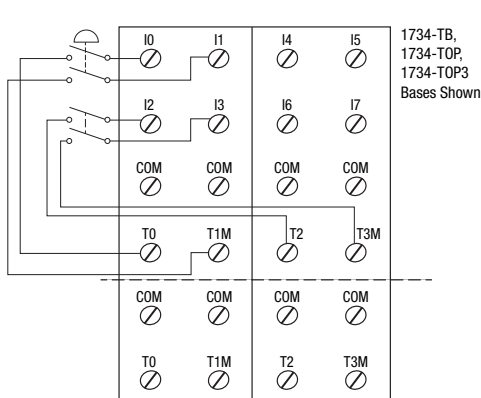

Controller Configuration	Parameter Name	Configuration Setting
Safety Input 0	Safety Input 0 Channel Mode	Test Pulse from Test Output
	Safety Input 0 Test Source	Test Output 0
	Dual-channel Safety Input 0/1 Mode	Dual-channel Equivalent
	Dual-channel Safety Input 0/1 Discrepancy Time	100 ms (application dependent)
Safety Input 1	Safety Input 1 Channel Mode	Test Pulse from Test Output
	Safety Input 1 Test Source	Test Output 1
Safety Input 2	Safety Input 2 Channel Mode	Safety Input
	Safety Input 2 Test Source	Test Output 2
	Dual-channel Safety Input 2/3 Mode	Dual-channel Equivalent
Safety Input 3	Safety Input 3 Channel Mode	Safety Input
	Safety Input 3 Test Source	Test Output 3
Test Output 0	Test Output 0 Mode	Pulse Test Output
Test Output 1	Test Output 1 Mode	Pulse Test Output
Test Output 2	Test Output 2 Mode	Power Supply Output
Test Output 3	Test Output 3 Mode	Power Supply Output

Rockwell 1734-OB8S with 1734-IB8S wiring schematic to interface to Safety Exhaust Valve

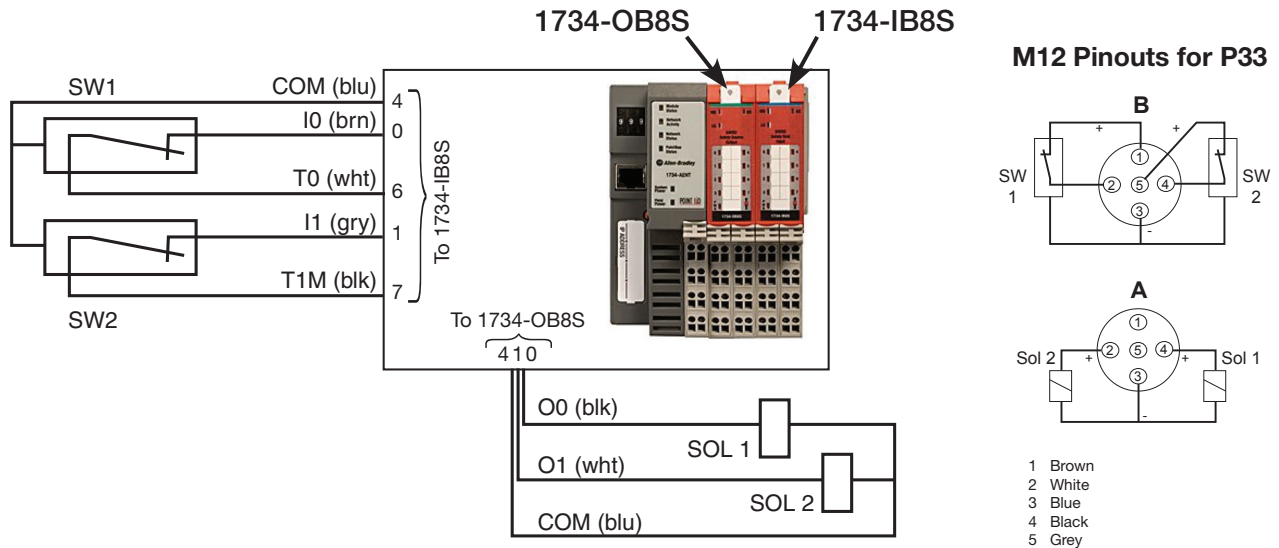

With this schematic it is possible to achieve up to Cat 4 PL e if properly implemented.

Module Configuration

Controller Configuration	Parameter Name	Configuration Setting	Controller Configuration	Parameter Name	Configuration Setting
Safety Output 0	Safety Output 0 Point Mode	Safety Pulse Test	Safety Input 0	Safety Input Channel Mode	Standard
	Point Operation Type	Dual-channel		Point Operation Type	Single-channel
Safety Output 1	Safety Output 1 Point Mode	Safety Pulse Test	Safety Input 1	Safety Input Channel Mode	Standard

Rockwell 1734-OBV2S with 1734-IB8S wiring schematic to interface to Safety Exhaust Valve

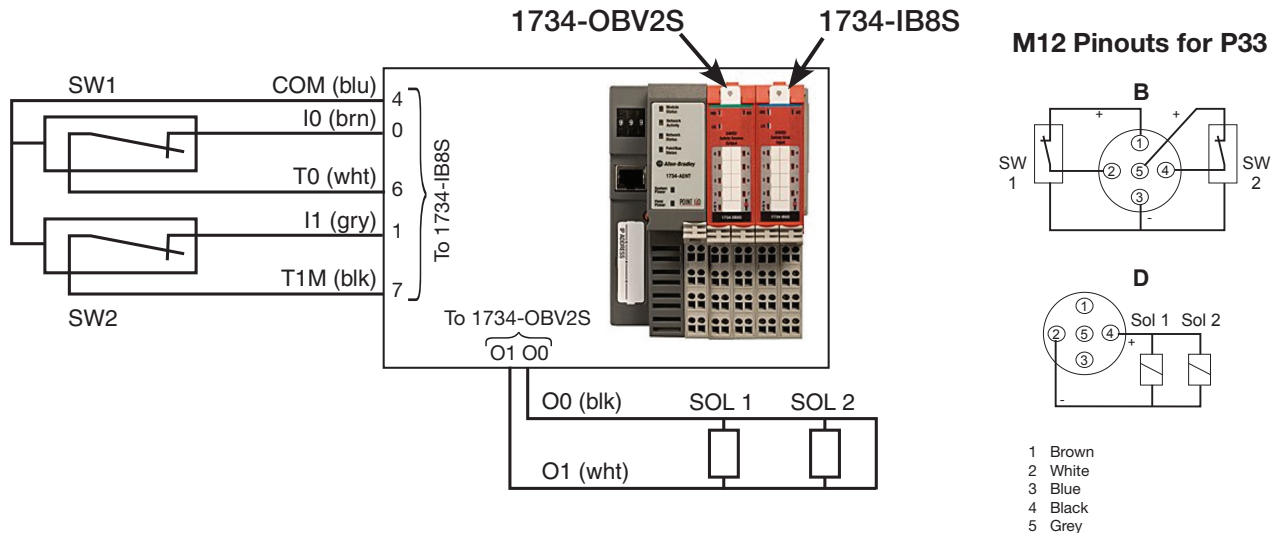

With this schematic it is possible to achieve up to Cat 4 PL e if properly implemented.

Module Configuration

Controller Configuration	Parameter Name	Configuration Setting	Controller Configuration	Parameter Name	Configuration Setting
Safety Output 0	Safety Output 0 Point Mode	Safety Pulse Test	Safety Input 0	Safety Input Channel Mode	Standard
Safety Output 1	Safety Output 1 Point Mode	Safety Pulse Test	Safety Input 1	Safety Input Channel Mode	Standard

External monitoring program for Rockwell 1734-OB8S or 1734-OBV2S with 1734-IB8S

- a) If $I0 = I1 = 1$ AND safety hardwire circuit in Active state AND no faults present THEN SET $O0 = O1 = 1$ when commanded
- b) Sensor discrepancy error: $I0 <> I1$ (max. discrepancy time = 150 msec)
- c) Loss of pressure error: $O0 = O1 = 1$ AND $I0 = I1 = 0$ followed by $I0 = 1$ OR $I1 = 1$ AND $O0 = O1 = 1$
- d) System pressure error: $O0 = O1 = 1$ AND $I0 = I1 = 1$ for x amount of time (where x is system pressurization time dependent on volume) Default 3 secs.
- e) IF sensor discrepancy error OR loss of pressure error OR system pressure error THEN reset $O0 = O1 = 0$

Errors must be reset only after maintenance acknowledgement

* Programs provided in this integration guide are for reference only. These programs have not been certified or tested unless stated otherwise.

Siemens ET200PRO Safe



Part Number: ET200PRO Safe
 Functional Safety Rating: Cat 4, PL e

- Uses M12
- Direct M12 Cable
- Central or IO modules
- Examples include with and without pin outs and valve schematic

Generic Connection Example (from Siemens Catalog):

Wiring diagram – connecting one two-channel sensor via two channels

One two-channel sensor is connected via two channels to two inputs of the F-module for each process signal (1oo2 evaluation).

The wiring is carried out at the appropriate connection module.

The figures below illustrate an example wiring diagram for channel groups 1 and 2.

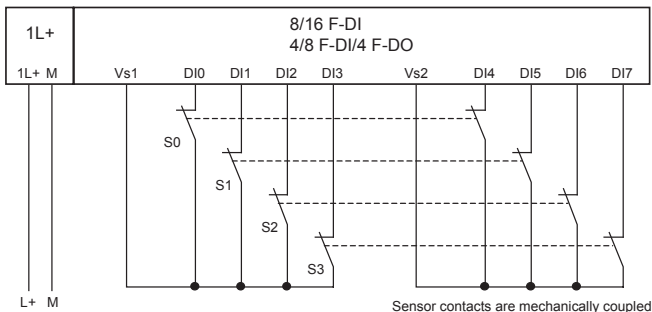

Wiring two leads in parallel in each digital output

Avoiding / managing cross circuits:

To protect against cross circuits between P- and M-switches of a fail-safe digital output, we recommend the following wiring schemes:

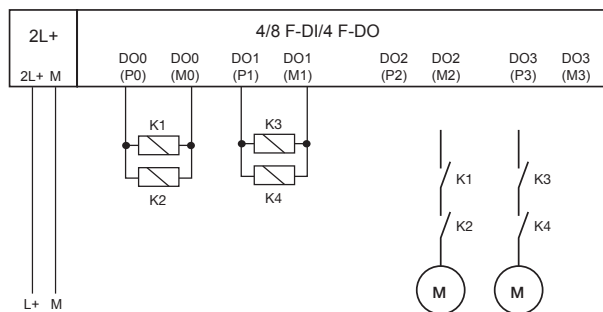

Wiring diagram for each of two relays parallel at one F-DO of the 4/8 F-DI/4 F-DO DC24V/2A PROFIsafe electronic module.

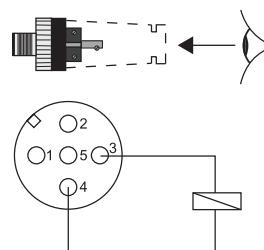
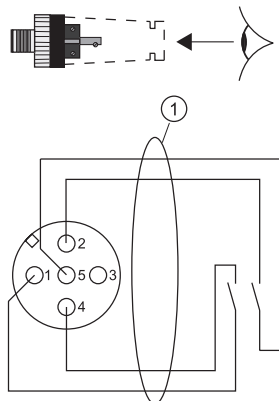

Siemens Wiring Schematic for ET200PRO Safe to Interface to Safety Exhaust Valve

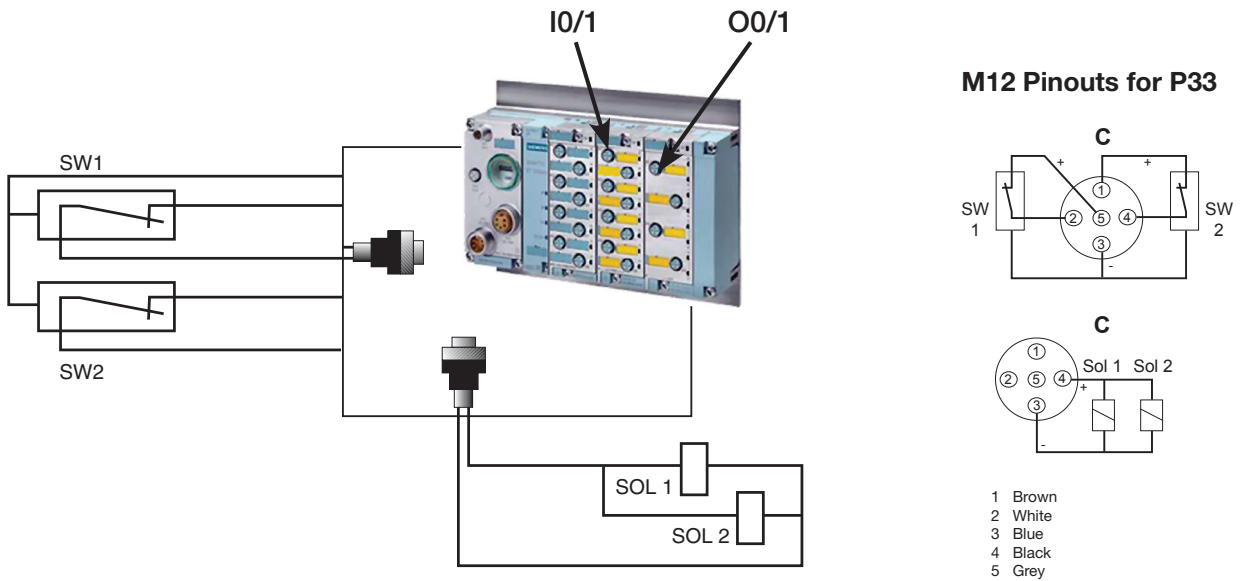

With this schematic it is possible to achieve up to category 4 PL e if properly implemented.

External monitoring program for Siemens ET200PRO Safe

- a) If I0 = I1 = 1 AND safety hardwire circuit in Active state AND no faults present THEN SET O0 = 1 when commanded
 - b) Sensor discrepancy error: I0 <> I1 (max. discrepancy time = 150 msec)
 - c) Loss of pressure error: O0 = 1 AND I0 = I1 = 0 followed by I0 = 1 OR I1 = 1 AND O0 = 1
 - d) System pressure error: O0 = 1 AND I0 = I1 = 1 for x amount of time (where x is system pressurization time dependent on volume) Default 3 secs.
 - e) IF sensor discrepancy error OR loss of pressure error OR system pressure error THEN reset O0 = 0
- Errors must be reset only after maintenance acknowledgement

* Programs provided in this integration guide are for reference only. These programs have not been certified or tested unless stated otherwise.

Siemens Simatic S7



Part Number: Simatic S7
Functional Safety Rating: Cat 4, PL e

- Uses Terminals
- Customer will have colored wires
- Central or IO modules
- Examples include with and without pin outs and valve schematic

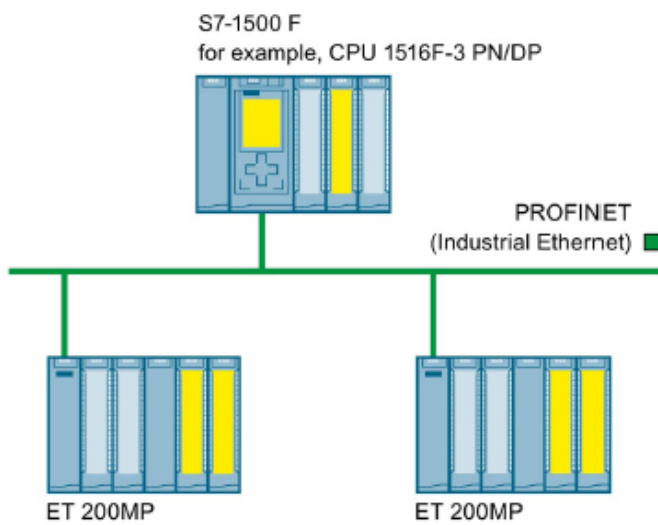

Generic Siemens Wiring Examples for S7 1200F (from Siemens Catalog):

Application 5 & 6: 1oo2 evaluation of independent equivalent sensors
 S0 and S8 can be dual contacts of a single sensor.

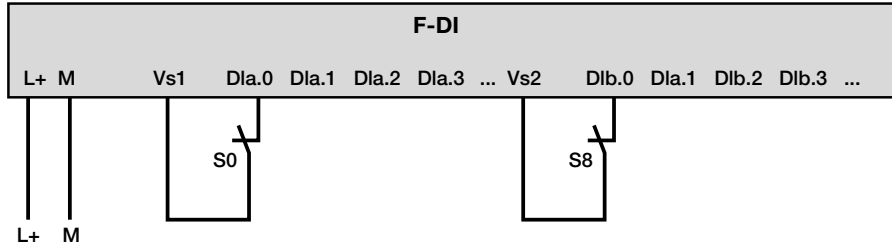

F-DI Application mode 5: Internal sensor supply

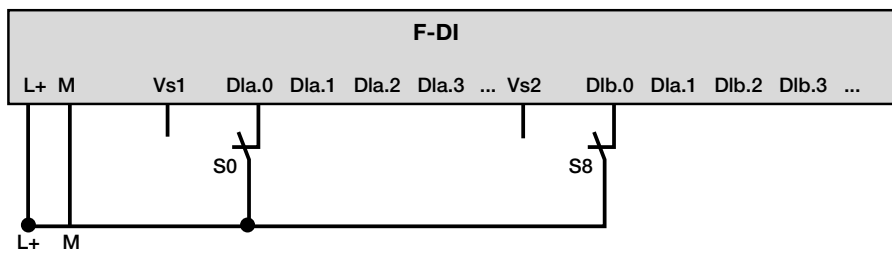

F-DI Application mode 6: External sensor supply

Application 2: Wiring external contractors: Separate P and M controlled contactors

A short-circuit between the P and M output can immediately lead to dangerous failure. You must prevent this failure mode by proper separation and protection of conductors.

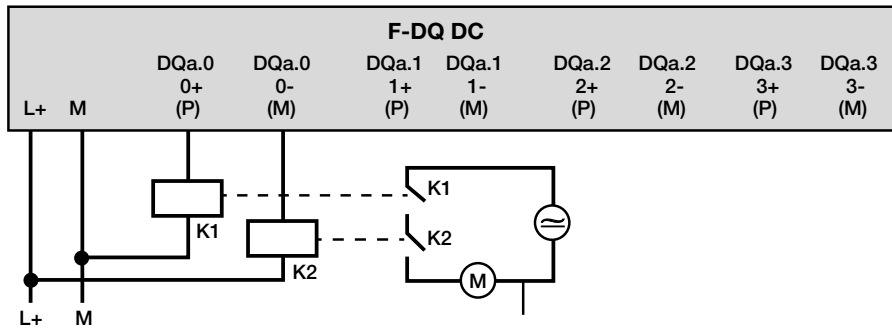

Application 3: Wiring external contractors: Parallel connected between P and M

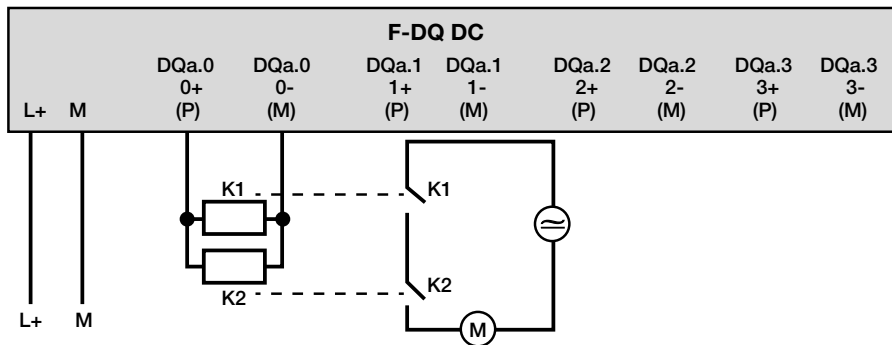

Siemens Wiring Schematic Safe Output without Sensor Test Pulse Version AC to Interface to Safety Exhaust Valve

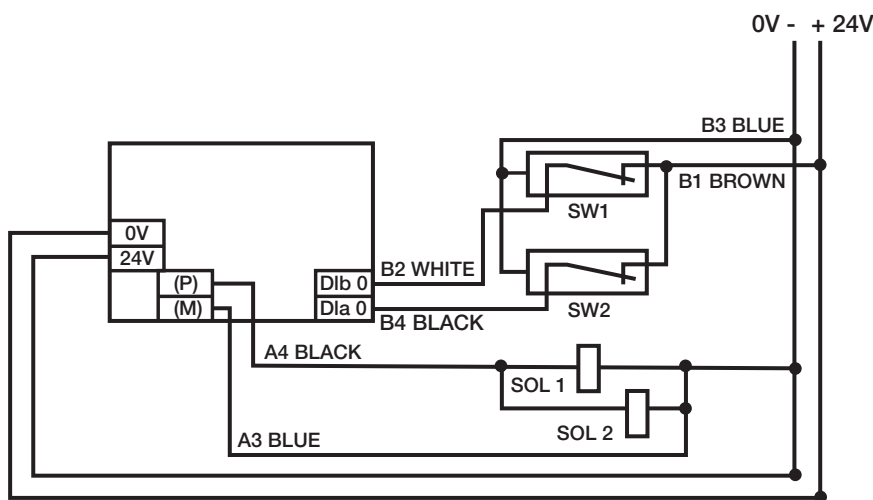

M12 Pinouts for P33

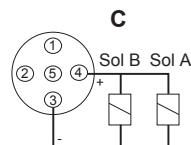
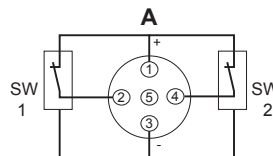

- 1 Brown
- 2 White
- 3 Blue
- 4 Black
- 5 Grey

With this schematic it is possible to achieve up to category 4 PL e if properly implemented.

Siemens Wiring Schematic Safe Output without Sensor Test Pulse Version CC to Interface to Safety Exhaust Valve

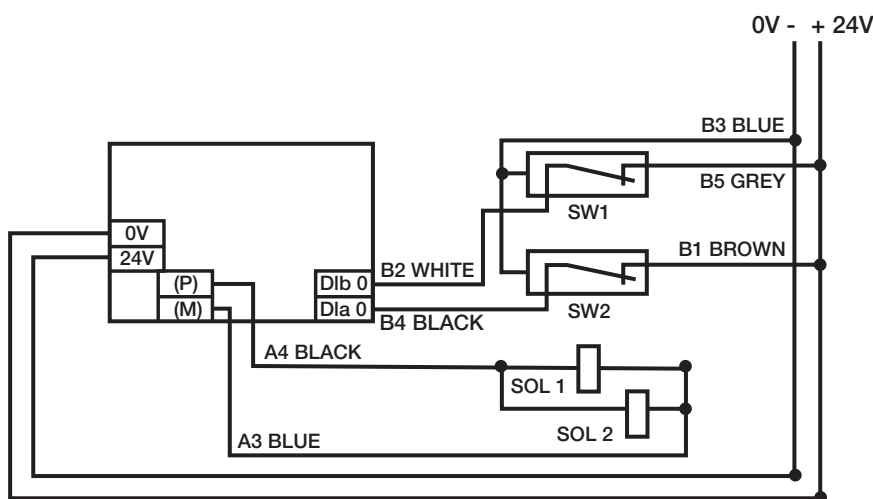

M12 Pinouts for P33

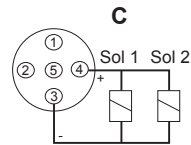
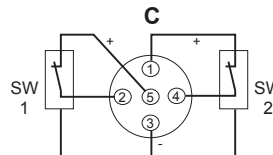

- 1 Brown
- 2 White
- 3 Blue
- 4 Black
- 5 Grey

With this schematic it is possible to achieve up to category 4 PL e if properly implemented.

Siemens Wiring Schematic Safe Output with Sensor Test Pulse to Interface to Safety Exhaust Valve

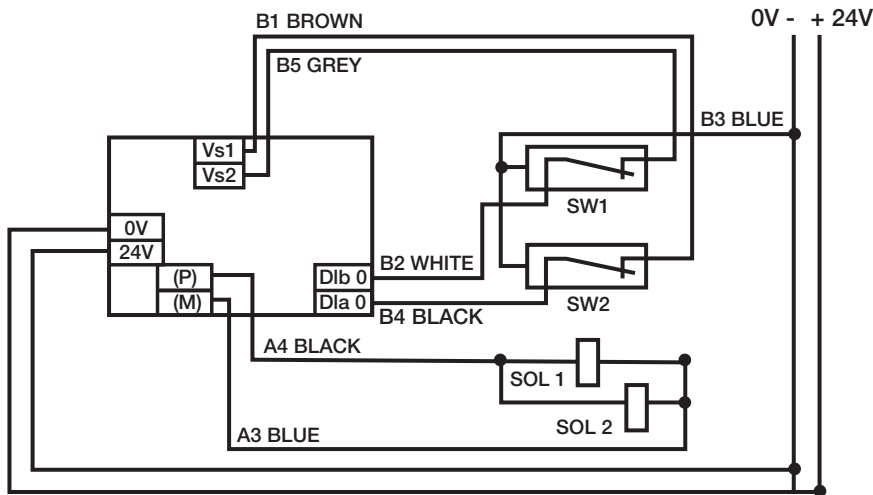

M12 Pinouts for P33

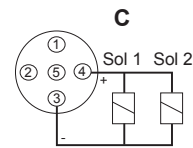
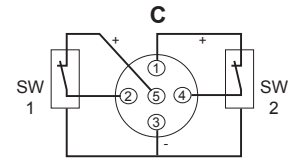

- 1 Brown
- 2 White
- 3 Blue
- 4 Black
- 5 Grey

With this schematic it is possible to achieve up to category 4 PL e if properly implemented.

External monitoring program for Siemens Simatic S7*

- a) If Dia.0 = Dib.0 = 1 AND safety hardwire circuit in Active state AND no faults present THEN SET O0 = 1 when commanded
- b) Sensor discrepancy error: Dia.0 <> Dib.0 (max. discrepancy time = 150 msec)
- c) Loss of pressure error: O0 = 1 AND Dia.0 = Dib.0 = 0 followed by Dia.0 OR Dib.0 AND O0 = 1
- d) System pressure error: O0 = 1 AND Dia.0 = Dib.0 = 1 for x amount of time (where x is system pressurization time dependent on volume) Default 3 secs.
- e) IF sensor discrepancy error OR loss of pressure error OR system pressure error THEN reset O0 = 0

Errors must be reset only after maintenance acknowledgement

* Programs provided in this integration guide are for reference only. These programs have not been certified or tested unless stated otherwise.

Turck TBPn-L1-FDIO1-2IOL



Functional Safety Rating: Cat 4, PL e

- Uses M12 connections
- Direct M12 cables
- Central or IO modules

Generic Connection Example (from Turck Catalog):

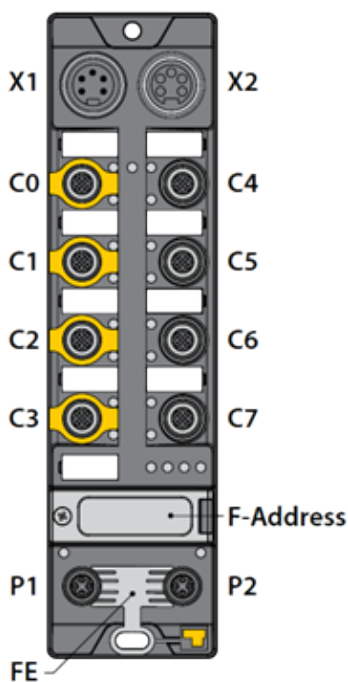

Meaning	Power IN
X2	Power OUT
C0	FDI0/1, safety input
C1	FDI2/3, safety input
C2	FDX4/5, safety in-/output
C3	FDX6/7, safety in-/output
C4	DXP8/9, standard in-/outputs (safe shutdown via FSO0 possible)
C5	DXP10/11, standard in-/outputs (safe shutdown via FSO0 possible)
C6	IOL, IO-Link port 1
C7	IOL, IO-Link port 2 (safe shutdown via FSO1 possible)
F-Address	Rotary coding switch for address setting for PROFI-safe (F-address setting)
P1	Ethernet 1
P2	Ethernet 2
FE	Functional earth

Generic Turck Wiring Schematic (from Turck Catalog):

Safety Integrity Level/Performance Level/Category

The devices are rated for applications up to:

- SIL3 according to EN/IEC/ 61508 and EN/EC 62061
- Category 4 / PL e according to EN ISO 13849-1

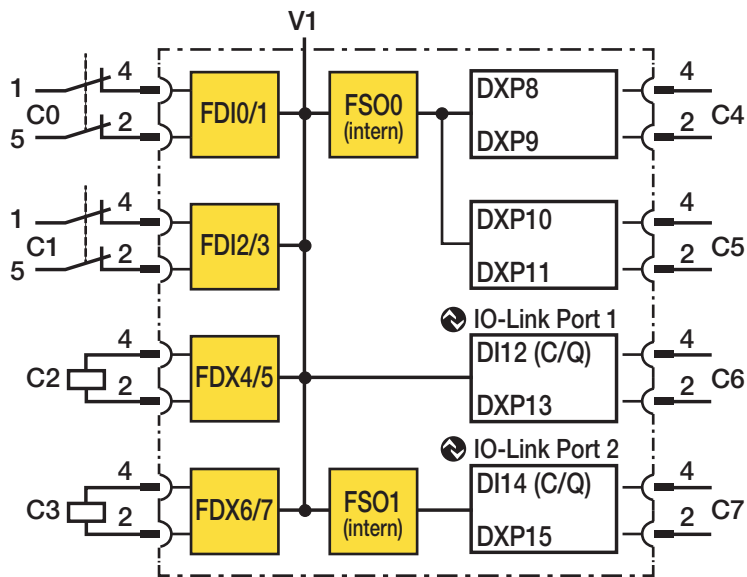

Turck Wiring Schematic TBN-L1-FDIO1-2IOL to Interface to Safety Exhaust Valve

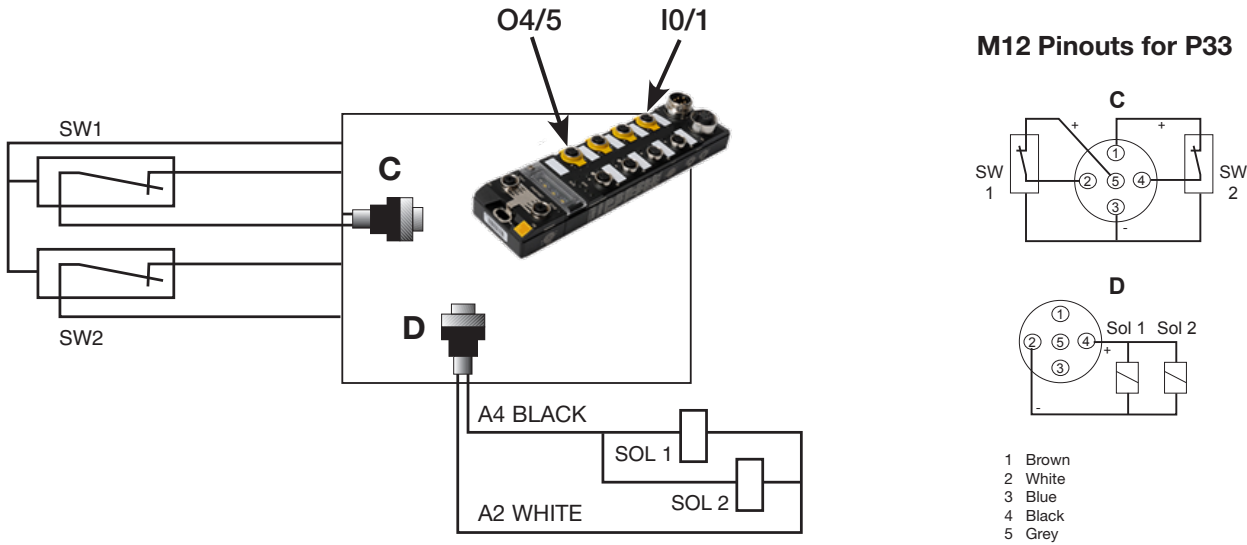

With this schematic it is possible to achieve up to category 4 PL e if properly implemented.

External monitoring program for Turck TBN-L1-FDIO1-2IOL

- a) If $I0 = I1 = 1$ AND safety hardwire circuit in Active state AND no faults present THEN SET $O4 = 1$ when commanded
- b) Sensor discrepancy error: $I0 <> I1$ (max. discrepancy time = 150 msec)
- c) Loss of pressure error: $O4 = 1$ AND $I0 = I1 = 0$ followed by $I0 = 1$ OR $I1 = 1$ AND $O4 = 1$
- d) System pressure error: $O4 = 1$ AND $I0 = I1 = 1$ for x amount of time (where x is system pressurization time dependent on volume) Default 3 secs.
- e) IF sensor discrepancy error OR loss of pressure error OR system pressure error THEN reset $O4 = 0$

Errors must be reset only after maintenance acknowledgement

* Programs provided in this integration guide are for reference only. These programs have not been certified or tested unless stated otherwise.

Parker Worldwide

Europe, Middle East, Africa

AE – United Arab Emirates,
Dubai

Tel: +971 4 8127100
parker.me@parker.com

AT – Austria, St. Florian
Tel: +43 (0)7224 66201
parker.austria@parker.com

AZ – Azerbaijan, Baku
Tel: +994 50 2233 458
parker.azerbaijan@parker.com

BE/NL/LU – Benelux,
Hendrik Ido Ambacht
Tel: +31 (0)541 585 000
parker.nl@parker.com

BG – Bulgaria, Sofia
Tel: +359 2 980 1344
parker.bulgaria@parker.com

BY – Belarus, Minsk
Tel: +48 (0)22 573 24 00
parker.poland@parker.com

CH – Switzerland, Etoy
Tel: +41 (0)21 821 87 00
parker.switzerland@parker.com

CZ – Czech Republic, Klecany
Tel: +420 284 083 111
parker.czechrepublic@parker.com

DE – Germany, Kaarst
Tel: +49 (0)2131 4016 0
parker.germany@parker.com

DK – Denmark, Ballerup
Tel: +45 43 56 04 00
parker.denmark@parker.com

ES – Spain, Madrid
Tel: +34 902 330 001
parker.spain@parker.com

FI – Finland, Vantaa
Tel: +358 (0)20 753 2500
parker.finland@parker.com

FR – France, Contamine s/Arve
Tel: +33 (0)4 50 25 80 25
parker.france@parker.com

GR – Greece, Piraeus
Tel: +30 210 933 6450
parker.greece@parker.com

HU – Hungary, Budaörs
Tel: +36 23 885 470
parker.hungary@parker.com

IE – Ireland, Dublin
Tel: +353 (0)1 466 6370
parker.ireland@parker.com

IL – Israel
Tel: +39 02 45 19 21
parker.israel@parker.com

IT – Italy, Corsico (MI)
Tel: +39 02 45 19 21
parker.italy@parker.com

KZ – Kazakhstan, Almaty
Tel: +7 7273 561 000
parker.easteurope@parker.com

NO – Norway, Asker
Tel: +47 66 75 34 00
parker.norway@parker.com

PL – Poland, Warsaw
Tel: +48 (0)22 573 24 00
parker.poland@parker.com

PT – Portugal
Tel: +351 22 999 7360
parker.portugal@parker.com

RO – Romania, Bucharest
Tel: +40 21 252 1382
parker.romania@parker.com

RU – Russia, Moscow
Tel: +7 495 645-2156
parker.russia@parker.com

SE – Sweden, Borås
Tel: +46 (0)8 59 79 50 00
parker.sweden@parker.com

SK – Slovakia, Banská Bystrica
Tel: +421 484 162 252
parker.slovakia@parker.com

SL – Slovenia, Novo Mesto
Tel: +386 7 337 6650
parker.slovenia@parker.com

TR – Turkey, Istanbul
Tel: +90 216 4997081
parker.turkey@parker.com

UA – Ukraine, Kiev
Tel: +48 (0)22 573 24 00
parker.poland@parker.com

UK – United Kingdom, Warwick
Tel: +44 (0)1926 317 878
parker.uk@parker.com

ZA – South Africa, Kempton Park
Tel: +27 (0)11 961 0700
parker.southafrica@parker.com

North America

CA – Canada, Milton, Ontario
Tel: +1 905 693 3000

US – USA, Cleveland
Tel: +1 216 896 3000

Asia Pacific

AU – Australia, Castle Hill
Tel: +61 (0)2-9634 7777

CN – China, Shanghai
Tel: +86 21 2899 5000

HK – Hong Kong
Tel: +852 2428 8008

IN – India, Mumbai
Tel: +91 22 6513 7081-85

JP – Japan, Tokyo
Tel: +81 (0)3 6408 3901

KR – South Korea, Seoul
Tel: +82 2 559 0400

MY – Malaysia, Shah Alam
Tel: +60 3 7849 0800

NZ – New Zealand, Mt Wellington
Tel: +64 9 574 1744

SG – Singapore
Tel: +65 6887 6300

TH – Thailand, Bangkok
Tel: +662 186 7000

TW – Taiwan, Taipei
Tel: +886 2 2298 8987

South America

AR – Argentina, Buenos Aires
Tel: +54 3327 44 4129

BR – Brazil, Sao Jose dos Campos
Tel: +55 800 727 5374

CL – Chile, Santiago
Tel: +56 2 623 1216

MX – Mexico, Toluca
Tel: +52 72 2275 4200



EMEA Product Information Centre

Free phone: 00 800 27 27 5374

(from AT, BE, CH, CZ, DE, DK, EE, ES, FI, FR, IE, IL,
IS, IT, LU, MT, NL, NO, PL, PT, RU, SE, SK, UK, ZA)

US Product Information Centre

Toll-free number: 1-800-27 27 537

www.parker.com