



Diaphragm Accumulators Maintenance and Installation



ENGINEERING YOUR SUCCESS.

Table of Contents	Page No.
Installation	3
Maintenance Instructions	4
Offer of Sale	7

In line with our policy of continuing product improvement, specifications and information contained in this catalog are subject to change.

Copyright ©2025 by Parker Hannifin Corporation. All rights reserved.

PRINTED IN THE U.S.A.

WARNING

FAILURE OR IMPROPER SELECTION OR IMPROPER USE OF THE PRODUCTS AND/OR SYSTEMS DESCRIBED HEREIN OR RELATED ITEMS CAN CAUSE DEATH, PERSONAL INJURY AND PROPERTY DAMAGE.

This document and other information from the Parker Hannifin Corporation, its subsidiaries and authorized distributors provide product and/or system options for further investigation by users having expertise. It is important that you analyze all aspects of your application, including consequences of any failure and review the information concerning the product or system in the current product catalog. Due to the variety of operating conditions and applications for these products or systems, the user, through its own analysis and testing, is solely responsible for making the final selection of the products and systems and assuring that all performance, safety and warning requirements of the application are met.

The products described herein, including without limitation, product features, specifications, designs, availability and pricing, are subject to change by Parker Hannifin Corporation and its subsidiaries at any time without notice.

Offer of Sale

The items described in this document are hereby offered for sale by Parker Hannifin Corporation, its subsidiaries or its authorized distributors. This offer and its acceptance are governed by provisions stated on a separate page of the document entitled 'Offer of Sale'.

⚠ PROP 65 WARNING **WARNING:** This product can expose you to chemicals including Lead and Lead Compounds which are known to the State of California to cause cancer and birth defects or other reproductive harm. For more information go to www.P65Warnings.ca.gov



Installation

Keep the hydraulic port covered to keep out foreign material until ready to make the hydraulic connection.

The accumulator should be rigidly mounted using appropriate mounting hardware, which is shown in the Accumulator Accessories section of this catalog. The hydraulic circuit, which contains a connection to the accumulator, should be designed so that it automatically discharges all hydraulic fluid from the accumulator when the equipment is turned off.

Pre-Charging Diaphragm Accumulators

Use an inert gas such as nitrogen for pre-charging accumulators.

If water pumped nitrogen is not available, oil-pumped nitrogen may be used. (C.G.A. standards: Nitrogen gas bottles for water pumped nitrogen has a right-hand valve thread which requires charging and gauging assembly 1486750000 for units up to 3600 psi. Oil-pumped nitrogen requires a left-handed valve thread (use 8700430000).

If equipment other than the above listed is used, make sure it is compatible with the gas valve assembly. Nitrogen source and all components must be rated for a pressure at least as high as the nitrogen source. It is strongly recommended that the nitrogen bottle used have a high pressure regulator.

Make sure nitrogen supply is shut off. Attach hose to nitrogen bottle. If accumulator has a gas valve as shown in Figure 5 follow steps A through K. If accumulator has a gas valve as shown in Figure 6, skip steps A through J and follow steps AA through JJ. Before starting, lubricate the shell and bladder by placing a small amount of system fluid in the oil port and rotate the accumulator a few times.

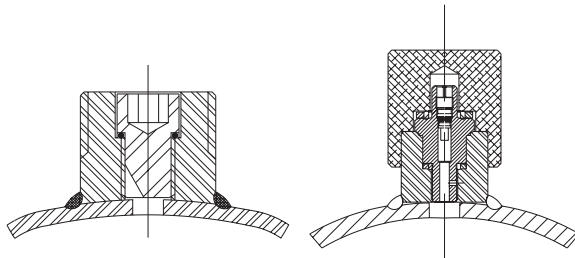

Figure 5

Figure 6

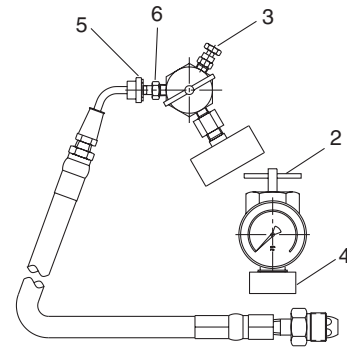

Figure 1

Accumulator having gas valve as per Figure 5.

- A Remove protective cover. Refer to Figure 1.
- B Turn charging device "T" handle (2) all the way in (clockwise) before attaching charging assembly.
- C Close bleed valve (3).
- D Making sure not to loop or twist the hose, attach nut (4) to gas valve and tighten.
- E Attach swivel nut (5) to gas valve (6) and tighten.
- F Turn "T" handle (2) in counterclockwise motion until rotation stops.
- G Crack open nitrogen bottle valve and slowly fill accumulator until the button is seated on the fluid port opening, then the nitrogen supply may be fully opened. Shut off the nitrogen supply when the gauge indicates 110% of desired pre-charge.
- H Let the pre-charge set for 1 to 2 minutes. This will allow the gas temperature to stabilize. Slowly open bleed valve (3) until the proper pressure is reached, then close the bleed valve (3).
- I When finished pre-charging accumulator, turn the "T" handle (2) clockwise all the way, then open bleed valve (3) to bleed the residual pressure from the charging device.
- J Holding the "T" handle (2) to keep from turning, loosen nut (4), and remove the assembly from the accumulator.
- K Torque the Allen head screw to 14.5 lbs-ft +3 (20 Nm +5).
- L Replace protective cap.

Pre-Charging Diaphragm Accumulator having gas valve as per Figure 6.

- AA Remove gas valve guard (A) and secondary seal (B) from the accumulator. Refer to Figure 2.
- BB Torque the gas valve to 9 lbs-ft + 1 (11.5 Nm + 1.3).
- CC On the charging device back the gas chuck (2) "T" handle all the way out (counterclockwise) before attaching the chuck to the Diaphragm accumulator.
- DD Make sure the bleed valve (3) is closed and tight.
- EE Making sure not to loop or twist the hose, attach the Swivel Connector (5) to the charging device gas valve (4) and tighten. (10-15 lbs in (11.5-17 cm kg))
- FF Turn the "T" handle (2) clockwise all the way. This action will depress the valve core.
- GG Crack open nitrogen bottle valve and slowly fill the accumulator until the button is seated on the fluid port opening, then the nitrogen supply may be fully opened. Shut off the nitrogen supply when gauge movement stops and indicates 110% of desired pre-charge level.
- HH Let the pre-charge set for 1 to 2 minutes. This will allow the gas temperature to stabilize. Slowly open bleed valve (3) until the proper pressure is reached.
- II When finished pre-charging, turn "T" handle (2) counterclockwise fully, then open the bleed valve (3) to release residual gas.
- JJ Hold the gas valve from turning and remove the charging device.
- KK Install secondary seal (B) and valve guard (A).

Note: For the most accurate results, use a gauge where the middle 1/3 of the gauge range encompasses the final pre-charge pressure.

Note: To ensure the most accuracy, use a temperature/ pre-charge correction chart or program.

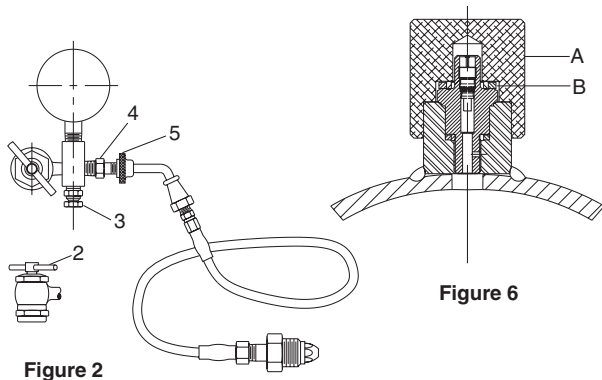

Figure 2

Figure 6

Pre-Charge Checking Procedure

For diaphragm units having a gas valve configured like Figure 5

Caution use this procedure only if the accumulator volume is equal to or more than 30 cubic inches in gas volume. For smaller volumes see the procedure for accumulators smaller than 30 cubic inch capacity.

Using appropriate valve in the hydraulic system, discharge all oil from accumulator and allow button to bottom against hydraulic port. Use pre-charge checking device P/N 1480240000 with proper gauge.

- A Remove protective cover from accumulator.
- B Refer to Figure 3. Turn the charging device "T" handle (2) all the way in (clockwise) attach charging and gauging head assembly by screwing mounting nut (4) to the gas end of the Diaphragm accumulator.
- C Close bleed valve (3).
- D Turn "T" handle (2) in counterclockwise motion until rotation stops.
- E When finished checking the pre-charge, turn "T" handle (2) clockwise all the way, then open bleed valve (3) to bleed all residual pressure from the charging device.
- F Hold "T" handle (2) to keep from turning, loosen nut (4), remove the assembly from the accumulator.
- G Torque the Allen head screw to 14.5 ft-lb + 3 (20 Nm + 9).
- H Replace protective cap.

Note: For the most accurate results, use a gauge where the middle 1/3 of the gauge range encompasses the final pre-charge pressure.

Note: To ensure the most accuracy, use a temperature/ pre-charge chart or program.

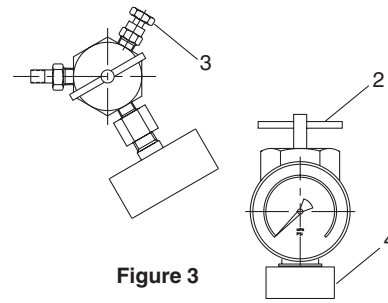

Figure 3

For diaphragm units having a gas valve configured like Figure 6

Caution use this procedure only if the accumulator volume is equal to or more than 30 cubic inches in gas volume. For smaller volumes see the procedure for accumulators smaller than 30 cu. in.

Using appropriate valve in the hydraulic system, discharge all oil from accumulator and allow button to bottom against hydraulic port. Use pre-charge checking device P/N 0851220000 with gauge.

- A Remove protective cover (A) and the secondary seal (B) from the Diaphragm accumulator. Check torque on the gas valve to be 9 lbs-ft (10.3 cm kg).
- B Refer to Figure 4. Back gas chuck "T" handle (2) all the way out (counterclockwise), attach charging and gauging head assembly by screwing the air chuck (2) to the valve stem of the Diaphragm accumulator and tighten (10-15 lbs in) (11.5-17 cm kg).
- C Close bleed valve (3).
- D Turn "T" handle (2) in clockwise motion.
- E When finished checking the pre-charge, turn "T" handle (2) clockwise all the way, then open bleed valve (3).
- F Using a wrench to prevent the gas valve assembly from rotating, remove the charging assembly from the accumulator.
- G Replace secondary seal (B) and protective cap (A).

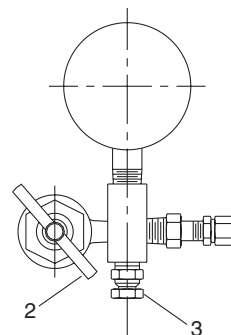

Figure 4

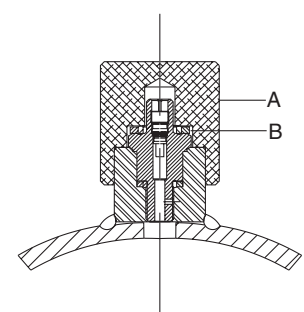

Figure 6

To check the pre-charge on units having a gas volume of less than 30 cu in.

It is recommended that the pre-charge be checked from the hydraulic port. Using this method will prevent the loss of gas volume necessary to get a pre-charge reading when using standard gas port mounted devices. This loss is attributable to the required gas volume filling the charging device thereby removing some volume from the accumulator. This removal causes a pre-charge drop due to the volume in the accumulator being so small.

Using the setup shown below in Figure 7, take the following steps to check the pre-charge.

If you wish to take a less accurate reading you may use the previously described methods, but be sure to have a nitrogen supply available to replenish the gas that will be lost during the pre-charge check.

- A Connect the accumulator fluid port to the pump discharge line.
- B Ensure that all fittings are tight and leakproof.
- C Bring hydraulic pressure up until the pre-charge is exceeded. You will know the pre-charge is exceeded when the resistance decreases and the gauge rise quickens.
- D Stop pumping and allow the pressure to stabilize.
- E Slowly crack the needle valve open until you see a very slow drop in pressure on the gauge.
- F At the gauge reading where the slow descent stops and a rapid descent starts is the pre-charge pressure in the accumulator.
- G It is recommended to take multiple readings to ensure accuracy of the reading.

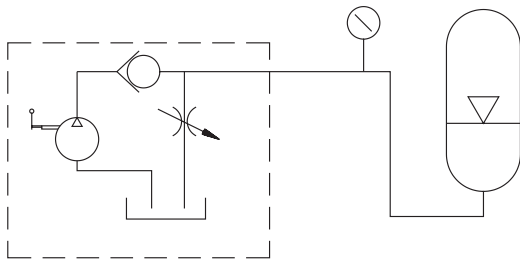

Figure 7

Removal from Hydraulic System

Shut the equipment down and make certain that hydraulic pressure at the accumulator is at zero.

For accumulators having gas valve as shown in Figure 5, attach gauging assembly as shown in Figure 3 following Steps A through D. Then, open bleed valve (3) until all gas pre-charge is relieved from accumulator. Then remove gauging assembly. The accumulator is now safe to remove from the system.

For accumulators having gas valve as shown in Figure 6, attach gauging assembly as shown in Figure 4 following Steps A through D. Then, open bleed valve (3) until all gas pre-charge is relieved from accumulator. Then remove gauging assembly. The accumulator is now safe to remove from the system.

Catalog HY10-2400-M1 Offer of Sale

The items described in this document and other documents and descriptions provided by Parker Hannifin Corporation, its subsidiaries and its authorized distributors ("Seller") are hereby offered for sale at prices to be established by Seller. This offer and its acceptance by any customer ("Buyer") shall be governed by all of the following Terms and Conditions. Buyer's order for any item described in its document, when communicated to Seller verbally, or in writing, shall constitute acceptance of this offer. All goods, services or work described will be referred to as "Products".

1. Terms. All sales of Products by Seller will be governed by, and are expressly conditioned upon Buyer's assent to, these Terms. These Terms are incorporated into any Quote provided by Seller to Buyer. Buyer's order for any Products whether communicated to Seller verbally, in writing, by electronic data interface or other electronic commerce, shall constitute acceptance of these Terms. Seller objects to any contrary or additional terms or conditions of Buyer. Reference in Seller's order acknowledgement to Buyer's purchase order or purchase order number shall in no way constitute an acceptance of any of Buyer's terms or conditions of purchase. Any Quote made by Seller to Buyer shall be considered a firm and definite offer and shall not be deemed to be otherwise despite any language on the face of the Quote. Seller reserves all rights to accept or reject any purported acceptance by Buyer to Seller's Quote if such purported acceptance attempts to vary the terms of the Quote. If Seller ships Products after Buyer issues an acceptance to the Quote, any additional or different terms proposed by Buyer will not become part of the parties' business relationship unless agreed to in a writing that is signed by an authorized representative of Seller, excluding email correspondence. If the transaction proceeds without such agreement on the part of Seller, the business relationship will be governed solely by these Terms and the specific terms in Seller's Quote.

2. Price; Payment. The Products set forth in the Quote are offered for sale at the prices indicated in the Quote. Unless otherwise specifically stated in the Quote, prices are valid for thirty (30) days and do not include any sales, use, or other taxes or duties. Seller reserves the right to modify prices for any reason and at any time by giving ten (10) days prior written notice. Unless otherwise specified by Seller, all prices are F.C.A. Seller's facility (INCOTERMS 2020). All sales are contingent upon credit approval and full payment for all purchases is due thirty (30) days from the date of invoice (or such date as may be specified in the Quote). Under any circumstances, Buyer may not withhold or suspend payment of any amounts due and payable as a deduction, set-off or recoupment of any amount, claim or dispute with Seller. Unpaid invoices beyond the specified payment date incur interest at the rate of 1.5% per month or the maximum allowable rate under applicable law. Seller reserves the right to require advance payment or provision of securities for first and subsequent deliveries if there is any doubt, in Seller's sole determination, regarding the Buyer's creditworthiness or for other business reasons. If the requested advance payment or securities are not provided to Seller's satisfaction, Seller reserves the right to suspend performance or reject the purchase order, in whole or in part, without prejudice to Seller's other rights or remedies, including the right to full compensation. Seller may revoke or shorten any payment periods previously granted in Seller's sole determination. The rights and remedies herein reserved to Seller are cumulative and in addition to any other or further rights and remedies available at law or in equity. No waiver by Seller of any breach by Buyer of any provision of these terms will constitute a waiver by Seller of any other breach of such provision.

3. Shipment; Delivery; Title and Risk of Loss. All delivery dates are approximate, and Seller is not responsible for damages or additional costs resulting from any delay. All deliveries are subject to our ability to procure materials from our suppliers. Regardless of the manner of shipment, delivery occurs and title and risk of loss or damage pass to Buyer, upon placement of the Products with the carrier at Seller's facility. Unless otherwise agreed prior to shipment and for domestic delivery locations only, Seller will select and arrange, at Buyer's sole expense, the carrier and means of delivery. When Seller selects and arranges the carrier and means of delivery, freight and insurance costs for shipment to the designated delivery location will be prepaid by Seller and added as a separate line item to the invoice. Buyer shall be responsible for any additional shipping charges incurred by Seller due to Buyer's acts or omissions. Buyer shall not return or repackage any Products without the prior written authorization from Seller, and any return shall be at the sole cost and expense of Buyer.

4. Warranty. The warranty for the Products is as follows: (i) Goods are warranted against defects in material or workmanship for a period of eighteen (18) months from the date of delivery or 2,000 hours of use, whichever occurs first; (ii) Services shall be performed in accordance with generally accepted practices and using the degree of care and skill that is ordinarily exercised and customary in the field to which the Services pertain and are warranted for a period of six (6) months from the date of completion of the Services; and (iii) Software is only warranted to perform in accordance with applicable specifications provided by Seller to Buyer for ninety (90) days from the date of delivery or, when downloaded by a Buyer or end-user, from the date of the initial download. All prices are based upon the exclusive limited warranty stated above, and upon the following disclaimer: **EXEMPTION CLAUSE; DISCLAIMER OF WARRANTY, CONDITIONS, REPRESENTATIONS: THIS WARRANTY IS THE SOLE AND ENTIRE WARRANTY, CONDITION, AND REPRESENTATION, PERTAINING TO PRODUCTS. SELLER DISCLAIMS ALL OTHER WARRANTIES, CONDITIONS, AND REPRESENTATIONS, WHETHER STATUTORY, EXPRESS OR IMPLIED, INCLUDING BUT NOT LIMITED TO THOSE RELATING TO DESIGN, NONINFRINGEMENT, MERCHANTABILITY, AND FITNESS FOR A PARTICULAR PURPOSE. SELLER DOES NOT WARRANT THAT THE SOFTWARE IS ERROR-FREE OR FAULT-TOLERANT, OR THAT BUYER'S USE THEREOF WILL BE SECURE OR UNINTERRUPTED, UNLESS OTHERWISE AUTHORIZED IN WRITING BY SELLER, THE SOFTWARE SHALL NOT BE USED IN CONNECTION WITH HAZARDOUS OR HIGH-RISK ACTIVITIES OR ENVIRONMENTS. EXCEPT AS EXPRESSLY STATED HEREIN, ALL PRODUCTS ARE PROVIDED "AS IS".**

5. Claims; Commencement of Actions. Buyer shall promptly inspect all Products upon receipt. No claims for shortages will be allowed unless reported to Seller within ten (10) days of delivery. Buyer shall notify Seller of any alleged breach of warranty within thirty (30) days after the date the non-conformance is or should have been discovered by Buyer. Any claim or action against Seller based upon breach of contract or any other theory, including tort, negligence, or otherwise must be commenced within twelve (12) months from the date of the alleged breach or other alleged event, without regard to the date of discovery.

6. LIMITATION OF LIABILITY. IN THE EVENT OF A BREACH OF WARRANTY, SELLER WILL, AT ITS OPTION, REPAIR OR REPLACE THE NON-CONFORMING PRODUCTS, RE-PERFORM THE SERVICES, OR REFUND THE PURCHASE PRICE PAID WITHIN A REASONABLE PERIOD OF TIME. IN NO EVENT IS SELLER LIABLE FOR ANY SPECIAL, INDIRECT, INCIDENTAL OR CONSEQUENTIAL DAMAGES INCLUDING ANY LOSS OF REVENUE OR PROFITS, WHETHER BASED IN CONTRACT, TORT OR OTHER LEGAL THEORY. IN NO EVENT SHALL SELLER'S LIABILITY UNDER ANY CLAIM MADE BY BUYER EXCEED THE PURCHASE PRICE PAID FOR THE PRODUCTS.

7. Confidential Information. Buyer acknowledges and agrees that Confidential Information has been and will be received in confidence and will remain the property of Seller. Buyer further agrees that it will not use Seller's Confidential Information for any purpose other than for the benefit of Seller and shall return all such Confidential Information to Seller within thirty (30) days upon request.

8. Loss to Buyer's Property. Buyer's Property will be considered obsolete and may be destroyed by Seller after two (2) consecutive years have elapsed without Buyer ordering the Products manufactured using Buyer's Property. Also, Seller shall not be responsible for any loss or damage to Buyer's Property while it is in Seller's possession or control.

9. Special Tooling. Seller may impose a tooling charge for any Special Tooling. Special Tooling shall be and remain Seller's property. In no event will Buyer acquire any interest in the Special Tooling, even if such Special Tooling has been specially converted or adapted for manufacture of Goods for Buyer and notwithstanding any charges paid by Buyer. Unless otherwise agreed, Seller has the right to alter, discard or otherwise dispose of any Special Tooling or other property owned by Seller in its sole determination at any time.

10. Security Interest. To secure payment of all sums due from Buyer, Seller retains a security interest in all Products delivered to Buyer, and Buyer's acceptance of these Terms is deemed to be a Security Agreement under the Uniform Commercial Code. Buyer authorizes Seller as its attorney to execute and file on Buyer's behalf all documents Seller deems necessary to perfect Seller's security interest.

11. User Responsibility. Buyer, through its own analysis and testing, is solely responsible for making the final selection of the Products and assuring that all performance, endurance, maintenance, safety and warning requirements of the application of the Products are met. Buyer must analyze all aspects of the application and follow applicable industry standards, specifications, and any technical information provided with the Quote or the Products, such as Seller's instructions, guides and specifications. If Seller provides options of or for Products based upon data or specifications provided by Buyer, Buyer is responsible for determining that such data and specifications are suitable and sufficient for all applications and reasonably foreseeable uses of the Products. In the event Buyer is not the end-user of the Products, Buyer will ensure such end-user complies with this paragraph.

12. Use of Products, Indemnity by Buyer. Buyer shall comply with all instructions, guides and specifications provided by Seller with the Quote or the Products. If Buyer uses or resells the Products in any way prohibited by Seller's instructions, guides or specifications, or Buyer otherwise fails to comply with Seller's instructions, guides and specifications, Buyer acknowledges that any such use, resale, or non-compliance is at Buyer's sole risk. Further, Buyer shall indemnify, defend, and hold Seller harmless from any losses, claims, liabilities, damages, lawsuits, judgments and costs (including attorney fees and defense costs), whether for personal injury, property damage, intellectual property infringement or any other claim, arising out of or in connection with: (a) improper selection, design, specification, application, or any misuse of Products; (b) any act or omission, negligent or otherwise, of Buyer; (c) Seller's use of Buyer's Property; (d)

Diaphragm Accumulators Maintenance and Installation Manual

damage to the Products from an external cause, repair or attempted repair by anyone other than Seller, failure to follow instructions, guides and specifications provided by Seller, use with goods not provided by Seller, or opening, modifying, deconstructing, tampering with or repackaging the Products; or (e) Buyer's failure to comply with these Terms, including any legal or administrative proceedings, collection efforts, or other actions arising from or relating to such failure to comply. Seller shall not indemnify Buyer under any circumstance except as otherwise provided in these Terms.

13. Cancellations and Changes. Buyer may not cancel or modify, including but not limited to movement of delivery dates for the Products, any order for any reason except with Seller's written consent and upon terms that will indemnify, defend and hold Seller harmless against all direct, incidental and consequential loss or damage and any additional expense. Seller, at any time, may change features, specifications, designs and availability of Products.

14. Assignment. Buyer may not assign its rights or obligations without the prior written consent of Seller.

15. Force Majeure. Seller is not liable for delay or failure to perform any of its obligations by reason of any events or circumstances beyond its reasonable control. Such circumstances include without limitation: accidents, labor disputes or stoppages, government acts or orders, acts of nature, pandemics, epidemics, other widespread illness, or public health emergency, cyber related disruptions, cyber-attacks, ransomware sabotage, delays or failures in delivery from carriers or suppliers, shortages of materials, sudden increases in the price of raw material or components, shutdowns or slowdowns affecting the supply of raw materials or components, or the transportation thereof, oil shortages or oil price increases, energy crisis, energy or fuel interruption, war (whether declared or not) or the serious threat of same, riots, rebellions, acts of terrorism, embargoes, fire or any reason whether similar to the foregoing or otherwise. Seller will resume performance as soon as practicable after the event of force majeure has been removed. All delivery dates affected by an event of force majeure shall be tolled for the duration of such event of force majeure and rescheduled for mutually agreed dates as soon as practicable after the event of force majeure ceases to exist. The right to allocate capacity is in the Seller's sole discretion. An event of force majeure shall not include financial distress, insolvency, bankruptcy, or other similar conditions affecting one of the parties, affiliates and/or sub-contractors. An event of force majeure in the meaning of these Terms means any circumstances beyond Seller's control that permanently or temporarily hinders performance, even where that circumstance was already foreseen. Buyer shall not be entitled to cancel any orders following its claim of an event of force majeure.

16. Waiver and Severability. Failure to enforce any provision of these Terms will not invalidate that provision; nor will any such failure prejudice either party's right to enforce that provision in the future. Invalidation of any provision of these Terms shall not invalidate any other provision herein and, the remaining provisions will remain in full force and effect.

17. Duration. Unless otherwise stated in the Quote, any agreement governed by or arising from these Terms shall: (a) be for an initial duration of one (1) year; and (b) shall automatically renew for successive one-year terms unless terminated by Buyer with at least 180-days written notice to Seller or if Seller terminates the agreement pursuant to Section 19 of these Terms.

18. Termination. Seller may, without liability to Buyer, terminate any agreement governed by or arising from these Terms for any reason and at any time by giving Buyer thirty (30) days prior written notice. Seller may immediately terminate, in writing, if Buyer: (a) breaches any provision of these Terms, (b) becomes or is deemed insolvent, (c) appoints or has appointed a trustee, receiver or custodian for all or any part of Buyer's property, (d) files a petition for relief in bankruptcy on its own behalf, or one is filed against Buyer by a third party, (e) makes an assignment for the benefit of creditors; or (f) dissolves its business or liquidates all or a majority of its assets.

19. Ownership of Rights. Buyer agrees that (a) Seller (and/or its affiliates) owns or is the valid licensee of Seller's IP and (b) the furnishing of information, related documents or other materials by Seller to Buyer does not grant or transfer any ownership interest or license in or to Seller's IP to Buyer, unless expressly agreed in writing. Without limiting the foregoing, Seller retains ownership of all Software supplied to Buyer. In no event shall Buyer obtain any greater right in and to the Software than a right in a license limited to the use thereof and subject to compliance with any other terms provided with the Software. Buyer further agrees that it will not, directly or through intermediaries, reverse engineer, decompile, or disassemble any Software (including firmware) comprising or contained within a Product, except and only to the extent that such activity may be expressly permitted, either by applicable law or, in the case of open source software, the applicable open source license.

20. Indemnity for Infringement of Intellectual Property Rights. Seller is not liable for infringement of any Intellectual Property Rights except as provided in this Section. Seller will defend at its expense and will pay the cost of any settlement or damages awarded in an action brought against Buyer based on a third-party claim that one or more of the Products infringes the Intellectual Property Rights of a third party in the country of delivery of the Products by Seller to Buyer. Seller's obligation to defend and indemnify Buyer is contingent on Buyer notifying Seller within ten (10) days after Buyer becomes aware of any such claim, and Seller having sole control over the defense of the claim including all negotiations for settlement or compromise. If one or more Products is subject to such a claim, Seller may, at its sole expense and option, procure for Buyer the right to continue using the Products, replace or modify the Products to render them non-infringing, or offer to accept return of the Products and refund the purchase price less a reasonable allowance for depreciation. Seller has no obligation or liability for any claim of infringement: (i) arising from information provided by Buyer (including Seller's use of Buyer's Property); or (ii) directed to any Products for which the designs are specified in whole or part by Buyer; or (iii) resulting from the modification, combination or use in a system of any Products. The foregoing provisions of this Section constitute Seller's sole and exclusive liability and Buyer's sole and exclusive remedy for claims of infringement of Intellectual Property Rights.

21. Governing Law. These Terms, the terms of any Quote, and the sale and delivery of all Products are deemed to have taken place in, and shall be governed and construed in accordance with, the laws of the State of Ohio, as applicable to contracts executed and wholly performed therein and without regard to conflicts of laws principles. Buyer irrevocably agrees and consents to the exclusive jurisdiction and venue of the courts of Cuyahoga County, Ohio with respect to any dispute, controversy or claim arising out of or relating to the sale and delivery of the Products.

22. Entire Agreement. These Terms, along with the terms set forth in the Quote, forms the entire agreement between the Buyer and Seller and constitutes the final, complete and exclusive expression of the terms of sale and purchase. In the event of a conflict between any term set forth in the Quote and these Terms, the terms set forth in the Quote shall prevail. All prior or contemporaneous written or oral agreements or negotiations with respect to the subject matter shall have no effect. No modification to these Terms will be binding on Seller unless agreed to in a writing that is signed by an authorized representative of Seller, excluding email correspondence, "clickwrap" or other purported electronic assent to different or additional terms. Sections 2-25 of these Terms shall survive termination or cancellation of any agreement governed by or arising from these Terms.

23. No "Wrap" Agreements/No Authority to Bind. Seller's clicking any buttons or any similar action, such as clicking "I Agree" or "Confirm," to utilize Buyer's software or webpage for the placement of orders, is NOT an agreement to Buyer's Terms and Conditions. NO EMPLOYEE, AGENT OR REPRESENTATIVE OF SELLER HAS THE AUTHORITY TO BIND SELLER BY THE ACT OF CLICKING ANY BUTTON OR SIMILAR ACTION ON BUYER'S WEBSITE OR PORTAL.

24. Compliance with Laws. Buyer agrees to comply with all applicable laws, regulations, and industry and professional standards, including those of the United States of America, and the country or countries in which Buyer may operate, including without limitation the U.S. Foreign Corrupt Practices Act ("FCPA"), the U.S. Anti-Kickback Act ("Anti-Kickback Act"), U.S. and E.U. export control and sanctions laws ("Export Laws"), the U.S. Food Drug and Cosmetic Act ("FDCA"), and the rules and regulations promulgated by the U.S. Food and Drug Administration ("FDA"), each as currently amended. Buyer agrees to indemnify, defend, and hold harmless Seller from the consequences of any violation of such laws, regulations and standards by Buyer, its employees or agents. Buyer represents that it is familiar with all applicable provisions of the FCPA, the Anti-Kickback Act, Export Laws, the FDCA and the FDA and certifies that Buyer will adhere to the requirements thereof and not take any action that would make Seller violate such requirements. Buyer represents and agrees that Buyer will not make any payment or give anything of value, directly or indirectly, to any governmental official, foreign political party or official thereof, candidate for foreign political office, or commercial entity or person, for any improper purpose, including the purpose of influencing such person to purchase Products or otherwise benefit the business of Seller. Buyer further represents and agrees that it will not receive, use, service, transfer or ship any Products from Seller in a manner or for a purpose that violates Export Laws or would cause Seller to be in violation of Export Laws. Buyer agrees to promptly and reliably provide Seller all requested information or documents, including end-user statements and other written assurances, concerning Buyer's ongoing compliance with Export Law. 9/22



Parker Hannifin Corporation
Cylinder and Accumulator Division
500 South Wolf Road
Des Plaines, IL 60016
phone (847) 298-2400
fax (847) 294-2655
www.parker.com/cylinder-accumulator

