

Pneumatic Division

Richland, Michigan USA

www.parker.com/pneumatics**PARTICULATE FILTERS**

Bulletin Number	Bulletin Description		
<input type="checkbox"/> 3F200	Rev. 1	02F Miniature In-line Filter	
<input type="checkbox"/> 2F101H	Rev. 14	05F Economy, Installation & Service	
<input type="checkbox"/> 2F101H	Rev. 14	06F "B&C" Compact, Installation & Service	
<input type="checkbox"/> 1F701B	—	06F / 07F Filter with Adsorber Element, Installation & Service	
<input type="checkbox"/> 2F101H	Rev. 14	07F "C" Standard, Installation & Service	
<input type="checkbox"/> 1F501D	Rev. 2	08F Elements	
<input type="checkbox"/> 1F800C	Rev. 6	09F "B" Hi-Flow, Installation & Service	
<input type="checkbox"/> 1F501D	Rev. 2	14F Miniature, 40 Micron Element	
<input type="checkbox"/> 1M301	Rev. 4	14F Miniature, Installation & Service	
<input type="checkbox"/> 1M105C	Rev. 1	8AF Miniature, Installation & Service	
<input type="checkbox"/> 2F400	Rev. 1	35F and 43F Large Ported, Installation & Service	
<input type="checkbox"/> 1F201F	Rev. 8	Auto Drain Installation	
<input type="checkbox"/> 1FL101H	Rev. 9	Bowl, Sight Gauge, Manual Drain, Service Procedure	
<input type="checkbox"/> 1F301C	Rev. 4	Drip Leg Drain Installation & Service	
<input type="checkbox"/> 2F102C	Rev. 4	Electronic DPI Installation & Service	
<input type="checkbox"/> IS-F602	Rev. 3	F602 Hi-Flow, Installation & Service	
<input type="checkbox"/> 5FRL100	Rev. 5	Global P3 Air Preparation Systems	
<input type="checkbox"/> P3Y-INC	Rev. 3	Global P3Y Hi-Flow, Installation & Service	
<input type="checkbox"/> 1FL301	Rev. 2	Mini Modular Bowl Kits	
<input type="checkbox"/> 2F300E	Rev. 9	P3N Hi-Flow, Installation & Service	
<input type="checkbox"/> 3F101	Rev. 1	PF602 Hi-Flow, Installation & Service	
<input type="checkbox"/> 1F107B	—	Prep-Air I Auto Drain Installation & Service	
<input type="checkbox"/> 1F105C	Rev. 1	Prep-Air I Filter Installation & Service	
<input type="checkbox"/> Safety Guide	—	PDN Safety Guide	



Visit www.pdnplu.com for additional instruction sheets.

⚠ WARNING

To avoid unpredictable system behavior that can cause personal injury and property damage:

- Disconnect electrical supply (when necessary) before installation, servicing, or conversion.
- Disconnect air supply and depressurize all air lines connected to this product before installation, servicing, or conversion.
- Operate within the manufacturer's specified pressure, temperature, and other conditions listed in these instructions.
- Medium must be moisture-free if ambient temperature is below freezing.
- Service according to procedures listed in these instructions.
- Installation, service, and conversion of these products must be performed by knowledgeable personnel who understand how pneumatic products are to be applied.
- After installation, servicing, or conversion, air and electrical supplies (when necessary) should be connected and the product tested for proper function and leakage. If audible leakage is present, or the product does not operate properly, do not put into use.
- Warnings and specifications on the product should not be covered by paint, etc. If masking is not possible, contact your local representative for replacement labels.

Introduction

Follow these instructions when installing, operating, or servicing the product.

Application Limits

These products are intended for use in general purpose compressed air systems only.

Operating Pressure Range: **kPa** **PSIG** **bar**

PLASTIC BOWL

w/ Manual Drain

Minimum	69	10	.69
Maximum	1034	150	10.34

w/ Internal Auto Drain

Minimum	207	30	2.07
Maximum	1034	150	10.34

w/ External Auto Drain

Minimum	345	50	3.45
Maximum	1034	150	10.34

METAL BOWL

w/ Manual Drain

Minimum	69	10	.69
Maximum	1724	250	17.24

w/ Internal Auto Drain

Minimum	207	30	2.07
Maximum	1207	175	12.07

w/ External Auto Drain

Minimum	345	50	3.45
Maximum	1034	150	10.34

Maximum Recommended Pressure Drop:

10 PSIG (Element should be cleaned)

Operating Temperature Range:

Filters w/ Plastic Bowls

-29°C * to 49°C (-20°F to 120°F)

Filters w/ Metal Bowls

Manual Drains -29°C * to 74°C (-20°F to 165°F)
 Automatic Drains -29°C * to 49°C (-20°F to 120°F)

* Temperatures below 0°C (32°F) require moisture free air.

Installation

1. Filter should be installed with reasonable accessibility for service whenever possible — repair service kits are available. Keep pipe or tubing lengths to a minimum with inside clean and free of dirt and chips. Pipe joint compound should be used sparingly and applied only to the male pipe — never into the female port. Do not use PTFE tape to seal pipe joints — pieces have a tendency to break off and lodge inside the unit, possibly causing malfunction. Also new pipe or hose should be installed between the filter and equipment being protected.
2. The upstream pipe work must be clear of accumulated dirt and liquids.
3. Select a filter location as close as possible to the equipment being protected and upstream of any pressure regulator.
4. Install filter so that air flows from "IN" to "OUT" as marked on the filter.
5. Install filter vertically with bowl drain mechanism at the bottom. Free moisture will thus drain into the sump ("quiet zone") at the bottom of the bowl.
6. Verify that lock ring is installed properly. If it is not, install lock ring and turn clockwise until it clicks into place. (See **Bowl Replacement** for more details.)

ANSI Symbols

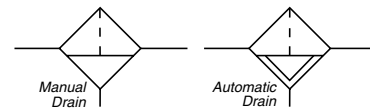

Operation

First Stage Filtration: Air enters at inlet port and flows through deflector (G) which causes a swirling action. Liquids and coarse particles are forced to the bowl interior wall (H) by the centrifugal action of the swirling air. They are then carried down the bowl by the force of gravity. The baffle (J) separates the lower portion of the bowl into a "quiet zone" (K) where the removed liquid and particles collect, unaffected by the swirling air, and are therefore not reentrained into the flowing air.

⚠ WARNING

FAILURE OR IMPROPER SELECTION OR IMPROPER USE OF THE PRODUCTS AND/OR SYSTEMS DESCRIBED HEREIN OR RELATED ITEMS CAN CAUSE DEATH, PERSONAL INJURY AND PROPERTY DAMAGE.

This document and other information from The Company, its subsidiaries and authorized distributors provide product and/or system options for further investigation by users having technical expertise. It is important that you analyze all aspects of your application, including consequences of any failure and review the information concerning the product or systems in the current product catalog. Due to the variety of operating conditions and applications for these products or systems, the user, through its own analysis and testing, is solely responsible for making the final selection of the products and systems and assuring that all performance, safety and warning requirements of the application are met.

The products described herein, including without limitation, product features, specifications, designs, availability and pricing, are subject to change by The Company and its subsidiaries at any time without notice.

EXTRA COPIES OF THESE INSTRUCTIONS ARE AVAILABLE FOR INCLUSION IN EQUIPMENT / MAINTENANCE MANUALS THAT UTILIZE THESE PRODUCTS. CONTACT YOUR LOCAL REPRESENTATIVE.

Prep-Air® I Air Line Filter

1F105C

Second Stage Filtration: After liquids and large particles are removed in the first stages of filtration, the air flows through element (C) where smaller particles are filtered out. The filtered air then passes downstream. Collected liquids and particles in the “quiet zone” (K) should be drained before their level reaches a height where they would be reentrained in the flowing air. This can be accomplished by unscrewing the drain valve (L) slightly until the liquid begins to drain.

Cleaning of Filter Element

1. Depress button on lock ring (A), turn counterclockwise and remove along with bowl assembly (B).
2. Remove the filter element (C) by turning it counterclockwise.
3. Clean the filter element (C) and bowl assembly (B) with MILD SOAP AND WATER ONLY! See CAUTION.
4. Reinstall the filter element (C) by turning it clockwise until it flexes slightly.
5. Reinstall the bowl assembly (B) and lock ring (A). Turn lock ring clockwise until it clicks into place.

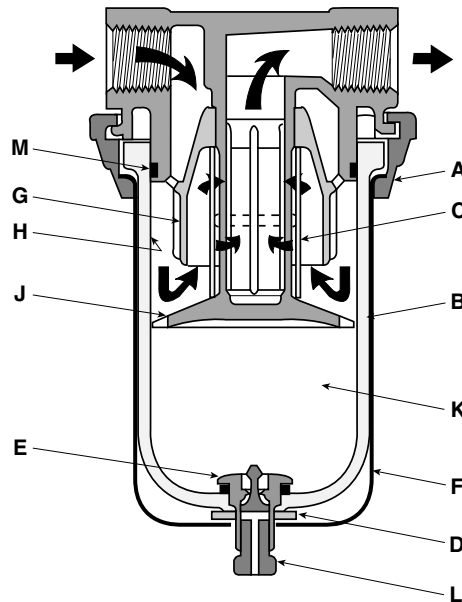

⚠ CAUTION

Polycarbonate bowls, being transparent and tough, are ideal for use with Filters and Lubricators. They are suitable for use in normal industrial environments, but should not be located in areas where they could be subjected to direct sunlight, an impact blow, nor temperatures outside of the rated range. As with most plastics, some chemicals can cause damage. Polycarbonate bowls should not be exposed to chlorinated hydro-carbons, ketones, esters and certain alcohols. They should not be used in air systems where compressors are lubricated with fire-resistant fluids, such as phosphate ester and di-ester types.

Metal bowls are recommended where ambient and/or media conditions are not compatible with polycarbonate bowls. Metal bowls resist the action of most such solvents, but should not be used where strong acids or bases are present or in salt laden atmospheres. Consult the factory for specific recommendations where these conditions exist.

TO CLEAN POLYCARBONATE BOWLS, USE MILD SOAP AND WATER ONLY! DO NOT use cleansing agents such as acetone, benzene, carbon tetrachloride, gasoline, toluene, etc., which are damaging to this plastic.

Bowl guards are recommended for added protection of polycarbonate bowls where chemical attack may occasionally occur.

Bowl Conversion / Replacement

1. Depress button on lock ring (A), turn counterclockwise and remove along with bowl assembly (B).
2. Install new bowl assembly (B) and lock ring (A). Turn lock ring clockwise until it clicks into place.

⚠ **WARNING:** Conversion or replacement of an old metal bowl with a new plastic bowl will reduce the product pressure / temperature rating. Be certain that the circuit and environment does not exceed the lower ratings; and that rating labels elsewhere on the product are replaced with one describing the lower rating. Failure to do so may cause property damage, injury or death.

Bowl Guard Installation

1. Depress button on lock ring (A), turn counterclockwise and remove.
2. Filters with External Automatic Drains - Remove float. Screw drain out bottom of bowl assembly while holding adapter with a screw driver from above.
3. Slip guard (F) over bowl.
4. Filters with External Automatic Drains - Screw drain into bottom of bowl assembly while holding adapter with a screw driver from above. Reinstall float into bowl assembly.
5. Reinstall the bowl assembly (B) and lock ring (A). Turn lock ring clockwise until it clicks into place.

Internal Automatic Drain Conversion

1. Depress button on lock ring (A), turn counterclockwise and remove along with bowl assembly (B).
2. Unscrew nut (D) and remove manual drain assembly (E).
3. Install internal automatic drain in bowl and tighten nut (D) from below.
4. Reinstall the bowl assembly and lock ring. Turn lock ring clockwise until it clicks into place.

⚠ **WARNING:** Conversion of a filter from a manual drain to an automatic drain will reduce the product pressure / temperature rating. Be certain that the circuit and environment does not exceed the lower ratings; and that rating labels elsewhere on the product are replaced with one describing the lower rating. Failure to do so may cause property damage, injury or death.

Service Kits / Parts

External Automatic Drain Service Kit - 03332 0208
(Standard and Full Size Filters ONLY)

Body Size	Port Size Inch	Lock Ring Assembly (A)	O-Ring (M)	Deflector (G)
Compact	1/8, 1/4	—	02709 7202B	—
Standard	1/4, 3/8, 1/2	03582 7502B	03454 7240B	03532 7002B
Full Size	3/4, 1	03586 7501B	03454 7247B	—

Accessories

Model	Compact Filter	Standard Filter	Full Size Filter
	03530 03531	03532 03533 03534	03536 03538
Bowl Guards	03530 0100B	03532 0100B	03536 0100B
Bowl Kits w/Manual Drain			
Polycarbonate	03530 0500B	03532 0500B	03536 0500B
Metal	03530 0400B	03532 0400B	03536 0400B
Drains			
Auto Drain - External	N/A	03332 0205B	03332 0205B
Auto Drain - Internal	PS506P	PS506P	PS506P
Manual Drain	PS512P	PS512P	PS512P
Elements			
5 Micron	N/A	03532 7203	03536 7203
10 Micron	03530 7203	N/A	N/A
30 Micron	03530 7030B	03532 7030B	03536 7030B
40 Micron	03530 7040	03532 7040	03536 7040
Pipe Mounting Bracket	00902 0400B	00902 0400B	00906 0400B

⚠ WARNING

To avoid unpredictable system behavior that can cause personal injury and property damage:

- Disconnect electrical supply (when necessary) before installation, servicing, or conversion.
- Disconnect air supply and depressurize all air lines connected to this product before installation, servicing, or conversion.
- Operate within the manufacturer's specified pressure, temperature, and other conditions listed in these instructions.
- Medium must be moisture-free if ambient temperature is below freezing.
- Service according to procedures listed in these instructions.
- Installation, service, and conversion of these products must be performed by knowledgeable personnel who understand how pneumatic products are to be applied.
- After installation, servicing, or conversion, air and electrical supplies (when necessary) should be connected and the product tested for proper function and leakage. If audible leakage is present, or the product does not operate properly, do not put into use.
- Warnings and specifications on the product should not be covered by paint, etc. If masking is not possible, contact your local representative for replacement labels.

Introduction

Follow these instructions when installing, operating, or servicing the product.

Application Limits

These products are intended for use in general purpose compressed air systems only.

Operating Pressure Range:

	kPa	PSIG	bar
Minimum	345	50	3.45
Maximum	1034	150	10.34

Operating Temperature Range:

-29°C * to 49°C (-20°F to 120°F)

* Temperatures below 0°C (32°F) require moisture free air.

External Automatic Drain Conversion

1. Depress button on lock ring, turn counterclockwise and remove along with bowl assembly.
2. Unscrew nut and remove manual drain assembly.
3. Install the larger of the two o-rings (5/8" outside diameter) on the adapter and insert into bowl from above. If the bowl has a flat bottom, assemble the smaller o-ring (9/16" outside diameter) from below.
4. Screw drain into place on outside of bowl while holding adapter in place with a screw driver. Install float on drain stem.
5. Reinstall the bowl assembly and lock ring. Turn lock ring clockwise until it clicks into place.

⚠ WARNING: Conversion of a filter/coalescer from a manual drain to an automatic drain will reduce the product pressure / temperature rating. Be certain that the circuit and environment does not exceed the lower ratings; and that rating labels elsewhere on the product are replaced with one describing the lower rating. Failure to do so may cause property damage, injury or death.

6. Remove port protector from 1/4" female drain port. If desired, connect piping to drain port.

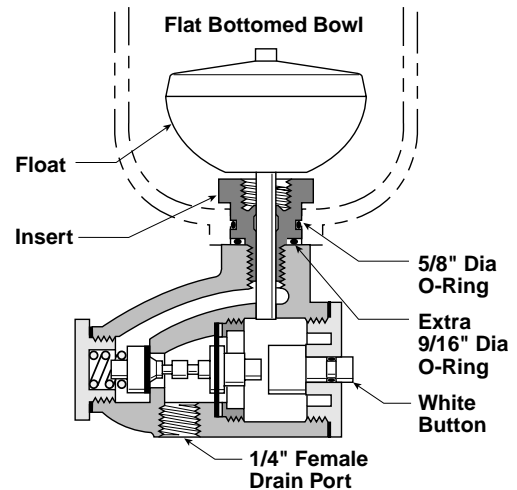
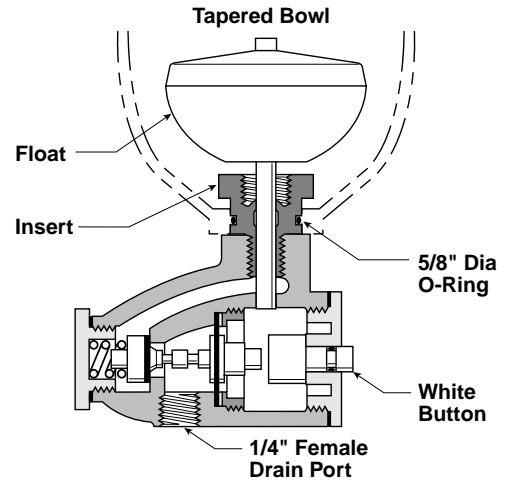

⚠ WARNING

FAILURE OR IMPROPER SELECTION OR IMPROPER USE OF THE PRODUCTS AND/OR SYSTEMS DESCRIBED HEREIN OR RELATED ITEMS CAN CAUSE DEATH, PERSONAL INJURY AND PROPERTY DAMAGE.

This document and other information from The Company, its subsidiaries and authorized distributors provide product and/or system options for further investigation by users having technical expertise. It is important that you analyze all aspects of your application, including consequences of any failure and review the information concerning the product or systems in the current product catalog. Due to the variety of operating conditions and applications for these products or systems, the user, through its own analysis and testing, is solely responsible for making the final selection of the products and systems and assuring that all performance, safety and warning requirements of the application are met.

The products described herein, including without limitation, product features, specifications, designs, availability and pricing, are subject to change by The Company and its subsidiaries at any time without notice.

EXTRA COPIES OF THESE INSTRUCTIONS ARE AVAILABLE FOR INCLUSION IN EQUIPMENT / MAINTENANCE MANUALS THAT UTILIZE THESE PRODUCTS. CONTACT YOUR LOCAL REPRESENTATIVE.

Automatic Drain Service

1. Remove nut on opposite end of drain from manual override. Remove bottom plug gasket (1) from nut and discard. Shake out disc spring (2) and inner valve assembly (3) and discard.
2. Remove nut on manual override end of drain. Remove bonnet gasket (4) and discard. Push override button out of nut. Remove and discard o-ring (5).
3. Remove diaphragm retainer using a spanner socket. If this tool is not available, insert a flat bladed screw driver into one of the slots and lightly tap it with a plastic mallet in the counterclockwise direction. Take care to avoid damage to the threads in the drain body.
4. Push diaphragm assembly (6) and diaphragm gasket (7) through from back side and discard.
5. Clean all retained parts with MILD SOAP AND WATER ONLY. See CAUTION at lower right.
6. Install diaphragm assembly (6), and diaphragm gasket (7). The sintered bronze plug should face the manual override end. Screw the diaphragm retainer into the body. Use a spanner socket to tighten the diaphragm retainer. If this tool is not available, insert a flat bladed screw driver into one of the slots and lightly tap it with a plastic mallet in the clockwise direction.
7. Install o-ring (5) onto override button and reinstall into nut. Install new bonnet gasket (4) onto nut and screw into drain body.
8. Insert inner valve assembly (3) into drain body making sure it is properly aligned with hole in diaphragm assembly (6). NOTE: This is easier if you push in the override button in first and can be verified by looking through the 1/4" drain hole.
9. Install disc spring (2) onto inner valve assembly (3). Install bottom plug gasket (1) onto nut and nut into drain body.

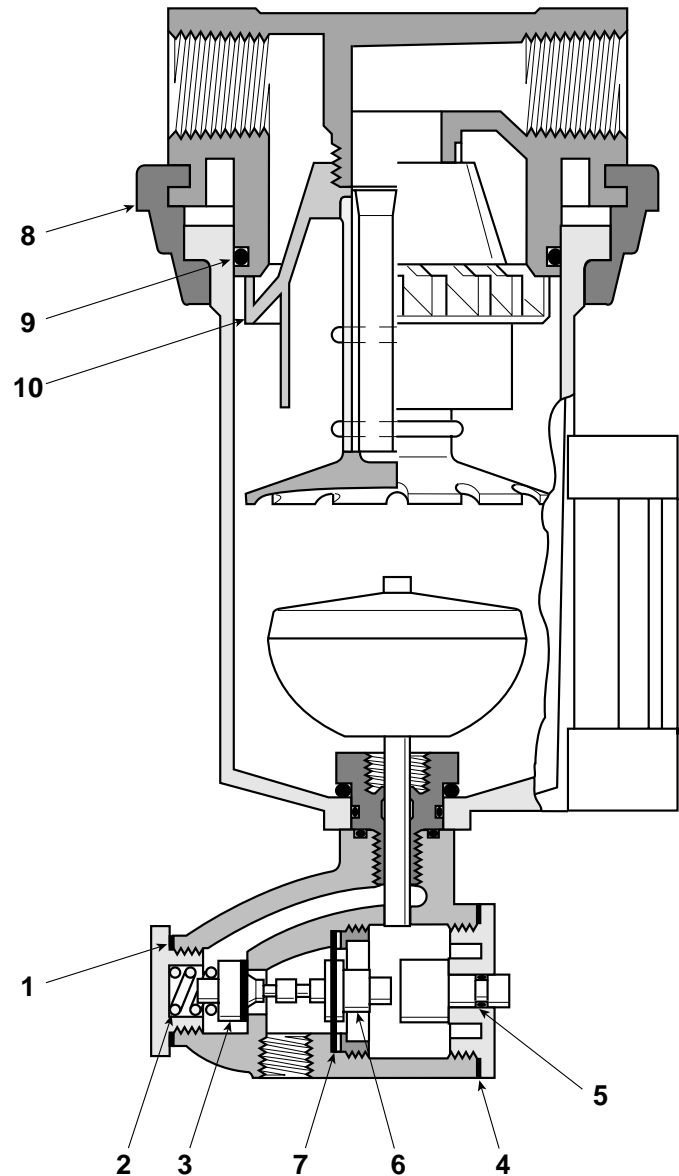

Service Kits / Parts:

External Automatic Drain Service Kit - 03332 0208
(Standard and Full Size Filters ONLY)

Body Size	Port Size Inch	Lock Ring Assembly (8)	O-Ring (9)	Deflector (10)
Compact	1/8, 1/4	—	02709 7202B	—
Standard	1/4, 3/8, 1/2	03582 7502B	03454 7240B	03532 7002B
Full Size	3/4, 1	03586 7501B	03454 7247B	—

Accessories

Model	Compact Filter	Standard Filter	Full Size Filter
	03530 03531	03532 03533 03534	03536 03538
Bowl Guards	03530 0100B	03532 0100B	03536 0100B
Bowl Kits w/Manual Drain	03530 0500B	03532 0500B	03536 0500B
Polycarbonate	03530 0400B	03532 0400B	03536 0400B
Metal			
Drains			
Auto Drain - External	N/A	03332 0205	03332 0205
Auto Drain - Internal	PS506P	PS506P	PS506P
Manual Drain	PS512P	PS512P	PS512P
Elements			
5 Micron	N/A	03532 7203	03536 7203
10 Micron	03530 7203	N/A	N/A
30 Micron	03530 7030B	03532 7030B	03536 7030B
40 Micron	03530 7040	03532 7040	03536 7040
Grade 6 Coalescing	N/A	03532 7021	03536 7521
Pipe Mounting Bracket	00902 0400B	00902 0400B	00906 0400B

CAUTION

Polycarbonate bowls, being transparent and tough, are ideal for use with Filters and Lubricators. They are suitable for use in normal industrial environments, but should not be located in areas where they could be subjected to direct sunlight, an impact blow, nor temperatures outside of the rated range. As with most plastics, some chemicals can cause damage. Polycarbonate bowls should not be exposed to chlorinated hydro-carbons, ketones, esters and certain alcohols. They should not be used in air systems where compressors are lubricated with fire-resistant fluids, such as phosphate ester and di-ester types.

Metal bowls are recommended where ambient and/or media conditions are not compatible with polycarbonate bowls. Metal bowls resist the action of most such solvents, but should not be used where strong acids or bases are present or in salt laden atmospheres. Consult the factory for specific recommendations where these conditions exist.

TO CLEAN POLYCARBONATE BOWLS, USE MILD SOAP AND WATER ONLY! DO NOT use cleansing agents such as acetone, benzene, carbon tetrachloride, gasoline, toluene, etc., which are damaging to this plastic.

Bowl guards are recommended for added protection of polycarbonate bowls where chemical attack may occasionally occur.

⚠ WARNING

To avoid unpredictable system behavior that can cause personal injury and property damage:

- Disconnect electrical supply (when necessary) before installation, servicing, or conversion.
- Disconnect air supply and depressurize all air lines connected to this product before installation, servicing, or conversion.
- Operate within the manufacturer's specified pressure, temperature, and other conditions listed in these instructions.
- Medium must be moisture-free if ambient temperature is below freezing.
- Service according to procedures listed in these instructions.
- Installation, service, and conversion of these products must be performed by knowledgeable personnel who understand how pneumatic products are to be applied.
- After installation, servicing, or conversion, air and electrical supplies (when necessary) should be connected and the product tested for proper function and leakage. If audible leakage is present, or the product does not operate properly, do not put into use.
- Warnings and specifications on the product should not be covered by paint, etc. If masking is not possible, contact your local representative for replacement labels.

⚠ CAUTION

Polycarbonate bowls, being transparent and tough, are ideal for use with Filters and Lubricators. They are suitable for use in normal industrial environments, but should not be located in areas where they could be subjected to direct sunlight, an impact blow, nor temperatures outside of the rated range. As with most plastics, some chemicals can cause damage. Polycarbonate bowls should not be exposed to chlorinated hydrocarbons, ketones, esters and certain alcohols. They should not be used in air systems where compressors are lubricated with fire-resistant fluids such as phosphate ester and diester types.

Metal bowls are recommended where ambient and/or media conditions are not compatible with polycarbonate bowls. Metal bowls resist the action of most such solvents, but should not be used where strong acids or bases are present or in salt laden atmospheres. Consult the factory for specific recommendations where these conditions exist.

TO CLEAN POLYCARBONATE BOWLS USE MILD SOAP AND WATER ONLY! DO NOT use cleansing agents such as acetone, benzene, carbon tetrachloride, gasoline, toluene, etc., which are damaging to this plastic.

Bowl guards are recommended for added protection of polycarbonate bowls where chemical attack may occasionally occur.

⚠ WARNING

To avoid polycarbonate bowl rupture that can cause personal injury or property damage, do not exceed bowl pressure or temperature ratings. Polycarbonate bowls have a 150 PSIG pressure rating and a maximum temperature rating of 125°F.

Safety Guide

For more complete information on recommended application guidelines, see the Safety Guide section of Pneumatic Division catalogs or you can download the **Pneumatic Division Safety Guide** at: www.parker.com/safety

Introduction

Follow these instructions when installing, operating, or servicing the product.

Application Limits

These products are intended for use in general purpose compressed air systems only.

Operating Pressure Range:

Polycarbonate Bowl	10 to 150 PSIG	(70 to 1030 kPa)
Metal Bowl	10 to 250 PSIG	(70 to 1720 kPa)

Ambient Temperature Range:

Polycarbonate Bowl	32°F to 125°F	(0°C to 52°C)
Metal Bowl	32°F to 175°F	(0°C to 80°C)

ANSI Symbol

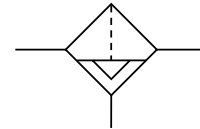

Filter w/Automatic Drain

Installation

To install the Auto Drain, SHUT OFF AiR SUPPLY and depressurize the unit.

1. Remove bowl by unscrewing bowl or collar, turning unlocking ring, or turn bayonet lock 1/8 turn.
2. Remove manual drain assembly from bowl. Be careful not to scratch or damage the inside surfaces of the bowl.
3. Clean or replace filter element. Clean bowl and all internal parts. See Polycarbonate bowl cleaning section.
4. Install Automatic Drain on inside of bowl (be sure O-ring is in place between drain and bowl).
5. Install retaining nut loosely - just to hold the drain in place.

⚠ WARNING

FAILURE OR IMPROPER SELECTION OR IMPROPER USE OF THE PRODUCTS AND/OR SYSTEMS DESCRIBED HEREIN OR RELATED ITEMS CAN CAUSE DEATH, PERSONAL INJURY AND PROPERTY DAMAGE.

This document and other information from The Company, its subsidiaries and authorized distributors provide product and/or system options for further investigation by users having technical expertise. It is important that you analyze all aspects of your application, including consequences of any failure and review the information concerning the product or systems in the current product catalog. Due to the variety of operating conditions and applications for these products or systems, the user, through its own analysis and testing, is solely responsible for making the final selection of the products and systems and assuring that all performance, safety and warning requirements of the application are met.

The products described herein, including without limitation, product features, specifications, designs, availability and pricing, are subject to change by The Company and its subsidiaries at any time without notice.

EXTRA COPIES OF THESE INSTRUCTIONS ARE AVAILABLE FOR INCLUSION IN EQUIPMENT / MAINTENANCE MANUALS THAT UTILIZE THESE PRODUCTS. CONTACT YOUR LOCAL REPRESENTATIVE.

6. Replace bowl seal. Lightly lubricate seal to assist with retaining it in position. Use only mineral based oils or grease. Do NOT use synthetic oils such as esters, and Do NOT use silicones.
7. Reassemble bowl into body. If using a 06F or 11F collar, tighten collar from 28 to 32 in-lbs (3.2 to 3.6 Nm) torque. If using a 07F or 12F collar, tighten collar from 48 to 52 in-lbs (5.4 to 5.9 Nm) torque.
8. Apply system pressure and tighten retaining nut by fingers - DO NOT over tighten.
9. Check for air leaks around bowl joints, on top and bottom, plus discharge hole of drain. Repeat all steps (including shutoff and depressurization) if leaks occur.

Parts Identification List

Item #	Description
1	Automatic Drain
2	O-ring - see step 4 of Installation section
3	Retaining Nut

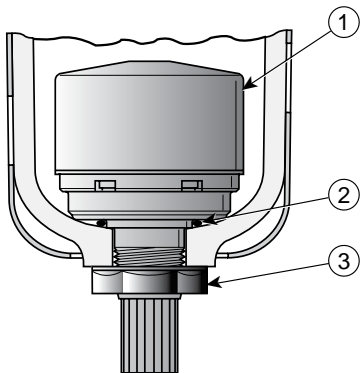

PS795 Automatic Drain with fluoroelastomer seals must be used with metal bowl.

⚠ WARNING

To avoid unpredictable system behavior that can cause personal injury and property damage:

- Disconnect electrical supply (when necessary) before installation, servicing, or conversion.
- Disconnect air supply and depressurize all air lines connected to this product before installation, servicing, or conversion.
- Operate within the manufacturer's specified pressure, temperature, and other conditions listed in these instructions.
- Medium must be moisture-free if ambient temperature is below freezing.
- Service according to procedures listed in these instructions.
- Installation, service, and conversion of these products must be performed by knowledgeable personnel who understand how pneumatic products are to be applied.
- After installation, servicing, or conversion, air and electrical supplies (when necessary) should be connected and the product tested for proper function and leakage. If audible leakage is present, or the product does not operate properly, do not put into use.
- Warnings and specifications on the product should not be covered by paint, etc. If masking is not possible, contact your local representative for replacement labels.

Introduction

Follow these instructions when installing, operating, or servicing the product.

Application Limits

These products are intended for use in general purpose compressed air systems only.

	kPa	PSIG	bar
Operating Pressure Minimum	68	10	0.68
Operating Pressure Maximum	1700	250	17.0

Operating Temperature Maximum: 80°C (175°F)

Installation

1. The automatic drip leg drain is 1/4" or 1/2" NPT ported and should be installed vertically in the lowest areas of a pneumatic system.
2. It is suggested that a globe valve be installed in front of the drip leg drain so the unit can be serviced without shutting off all air lines.
3. The auto-drain is ported 1/8" NPT on the bottom to pipe away any liquid discharged.

Maintenance

The automatic drip-leg drain can be easily serviced without removal of entire unit. Tools are not required.

1. Before servicing, shut off air supply and depressurize the unit.
 - a. Unscrew the body from the cap.
 - b. To remove auto-drain, unscrew the insert nut.
 - c. Thoroughly clean the interior of the body.
 - d. Install automatic drain on inside of body (be sure o-ring is in place between drain and body).
 - e. Thread knurled insert nut into position and tighten to 25-30 inch-pounds torque.
 - f. Replace body to cap o-ring seal; lubricate seal to assist in retaining it in position. NOTE: Use only mineral base oils or grease. Do not use synthetic oils such as esters.

- g. Screw body onto the cap, engaging all threads to the shoulder stop.
- h. Turn on air supply and check for air leaks around body joints, on top and bottom, plus discharge hole of drain. Repeat all steps (including shutoff and depressurization) if leak is experienced.

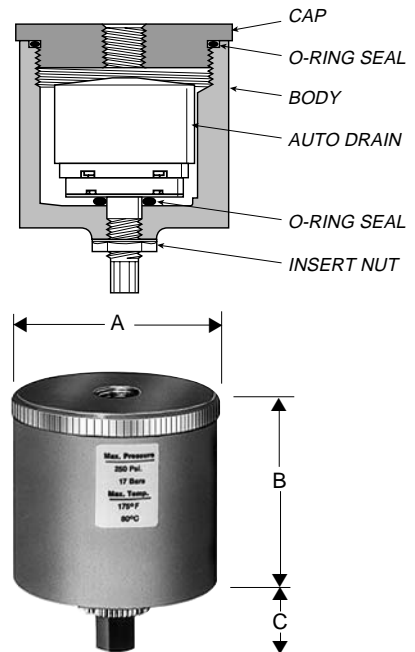

Dimensions

A		B		C	
2.50	63.5mm	2.37	60.2mm	.87	22.1mm

Kits Available

Kit No.	Description
PS506	Automatic Drain Kit

⚠ WARNING

FAILURE OR IMPROPER SELECTION OR IMPROPER USE OF THE PRODUCTS AND/OR SYSTEMS DESCRIBED HEREIN OR RELATED ITEMS CAN CAUSE DEATH, PERSONAL INJURY AND PROPERTY DAMAGE.

This document and other information from The Company, its subsidiaries and authorized distributors provide product and/or system options for further investigation by users having technical expertise. It is important that you analyze all aspects of your application, including consequences of any failure and review the information concerning the product or systems in the current product catalog. Due to the variety of operating conditions and applications for these products or systems, the user, through its own analysis and testing, is solely responsible for making the final selection of the products and systems and assuring that all performance, safety and warning requirements of the application are met.

The products described herein, including without limitation, product features, specifications, designs, availability and pricing, are subject to change by The Company and its subsidiaries at any time without notice.

EXTRA COPIES OF THESE INSTRUCTIONS ARE AVAILABLE FOR INCLUSION IN EQUIPMENT / MAINTENANCE MANUALS THAT UTILIZE THESE PRODUCTS. CONTACT YOUR LOCAL REPRESENTATIVE.

 **WARNING**

To avoid unpredictable system behavior that can cause personal injury and property damage:

- **Disconnect electrical supply (when necessary) before installation, servicing, or conversion.**
- **Disconnect air supply and depressurize all air lines connected to this product before installation, servicing, or conversion.**
- **Operate within the manufacturer's specified pressure, temperature, and other conditions listed in these instructions.**
- **Medium must be moisture-free if ambient temperature is below freezing.**
- **Service according to procedures listed in these instructions.**
- **Installation, service, and conversion of these products must be performed by knowledgeable personnel who understand how pneumatic products are to be applied.**
- **After installation, servicing, or conversion, air and electrical supplies (when necessary) should be connected and the product tested for proper function and leakage. If audible leakage is present, or the product does not operate properly, do not put into use.**
- **Warnings and specifications on the product should not be covered by paint, etc. If masking is not possible, contact your local representative for replacement labels.**

 **CAUTION**

Polycarbonate bowls, being transparent and tough, are ideal for use with Filters and Lubricators. They are suitable for use in normal industrial environments, but should not be located in areas where they could be subjected to direct sunlight, an impact blow, nor temperatures outside of the rated range. As with most plastics, some chemicals can cause damage. Polycarbonate bowls should not be exposed to chlorinated hydrocarbons, ketones, esters and certain alcohols. They should not be used in air systems where compressors are lubricated with fire-resistant fluids such as phosphate ester and diester types.

Metal bowls are recommended where ambient and/or media conditions are not compatible with polycarbonate bowls. Metal bowls resist the action of most such solvents, but should not be used where strong acids or bases are present or in salt laden atmospheres. Consult the factory for specific recommendations where these conditions exist.

TO CLEAN POLYCARBONATE BOWLS USE MILD SOAP AND WATER ONLY! DO NOT use cleansing agents such as acetone, benzene, carbon tetrachloride, gasoline, toluene, etc., which are damaging to this plastic.

Bowl guards are recommended for added protection of polycarbonate bowls where chemical attack may occasionally occur.

Introduction

Follow these instructions when installing, operating, or servicing the product.

Application Limits

These products are intended for use in general purpose compressed air systems only.

Operation

1. Both free moisture and solids are removed automatically by the filter. There are no moving parts.
2. Manual drain filter must be drained regularly before the separated moisture and oil reaches the bottom of the lower baffle. Automatic drain models will collect and dump liquids automatically.

Maintenance

1. The filter element should be removed and replaced when the pressure differential across the filter unit exceeds 10 PSIG.
2. To service the filter element; **SHUT OFF AIR SUPPLY** and depressurize the unit.
 - a. Unscrew threaded bowl.
 - b. Unscrew lower filter retainer and remove filter element (and two gaskets if present).
 - c. Clean all internal parts and bowl before reassembling. See polycarbonate bowl cleaning **CAUTION**.
 - d. (Applies to units with filter post design). If filter is removed from body replace o-ring on filter post with o-ring found in kit; lubricate o-ring with grease included in kit. Screw filter post into body.
 - e. Install new element (and two new gaskets if found in kit).
 - f. Screw on lower filter retainer and tighten firmly.
 - g. Replace bowl seal; lubricate seal to assist in retaining it in position. Use only mineral base oils or grease included in kit. **DO NOT** use synthetic oils such as esters, and **DO NOT** use silicones.
 - h. Screw bowl into body.
 - i. Apply pressure and check for leaks. If leaks occur, shut off air supply, depressurize the unit and correct leaks.

 **WARNING**

FAILURE OR IMPROPER SELECTION OR IMPROPER USE OF THE PRODUCTS AND/OR SYSTEMS DESCRIBED HEREIN OR RELATED ITEMS CAN CAUSE DEATH, PERSONAL INJURY AND PROPERTY DAMAGE.

This document and other information from The Company, its subsidiaries and authorized distributors provide product and/or system options for further investigation by users having technical expertise. It is important that you analyze all aspects of your application, including consequences of any failure and review the information concerning the product or systems in the current product catalog. Due to the variety of operating conditions and applications for these products or systems, the user, through its own analysis and testing, is solely responsible for making the final selection of the products and systems and assuring that all performance, safety and warning requirements of the application are met.

The products described herein, including without limitation, product features, specifications, designs, availability and pricing, are subject to change by The Company and its subsidiaries at any time without notice.

EXTRA COPIES OF THESE INSTRUCTIONS ARE AVAILABLE FOR INCLUSION IN EQUIPMENT / MAINTENANCE MANUALS THAT UTILIZE THESE PRODUCTS. CONTACT YOUR LOCAL REPRESENTATIVE.

Pneumatic Division
Richland, Michigan 49083
269-629-5000

Installation & Service Instructions:
1F701B

06F & 07F Filter
with Adsorber Element

ISSUED: January, 2004

Supersedes: January, 1993

Doc.# 1F701, ECN# 030539

 **WARNING**

To avoid unpredictable system behavior that can cause personal injury and property damage:

- Disconnect electrical supply (when necessary) before installation, servicing, or conversion.
- Disconnect air supply and depressurize all air lines connected to this product before installation, servicing, or conversion.
- Operate within the manufacturer's specified pressure, temperature, and other conditions listed in these instructions.
- Medium must be moisture-free if ambient temperature is below freezing.
- Service according to procedures listed in these instructions.
- Installation, service, and conversion of these products must be performed by knowledgeable personnel who understand how pneumatic products are to be applied.
- After installation, servicing, or conversion, air and electrical supplies (when necessary) should be connected and the product tested for proper function and leakage. If audible leakage is present, or the product does not operate properly, do not put into use.
- Warnings and specifications on the product should not be covered by paint, etc. If masking is not possible, contact your local representative for replacement labels.

 **CAUTION**

Polycarbonate bowls, being transparent and tough, are ideal for use with Filters and Lubricators. They are suitable for use in normal industrial environments, but should not be located in areas where they could be subjected to direct sunlight, an impact blow, nor temperatures outside of the rated range. As with most plastics, some chemicals can cause damage. Polycarbonate bowls should not be exposed to chlorinated hydrocarbons, ketones, esters and certain alcohols. They should not be used in air systems where compressors are lubricated with fire-resistant fluids such as phosphate ester and diester types.

Metal bowls are recommended where ambient and/or media conditions are not compatible with polycarbonate bowls. Metal bowls resist the action of most such solvents, but should not be used where strong acids or bases are present or in salt laden atmospheres. Consult the factory for specific recommendations where these conditions exist.

TO CLEAN POLYCARBONATE BOWLS USE MILD SOAP AND WATER ONLY! DO NOT use cleansing agents such as acetone, benzene, carbon tetrachloride, gasoline, toluene, etc., which are damaging to this plastic.

Bowl guards are recommended for added protection of polycarbonate bowls where chemical attack may occasionally occur.

Introduction

Follow these instructions when installing, operating, or servicing the product.

Application Limits

These products are intended for use in general purpose compressed air systems only.

Adsorption techniques are **not effective** on: carbon monoxide, carbon dioxide, methane, ethane, ethylene or hydrogen. For a more complete list of vapors that can and cannot be adsorbed effectively by activated charcoal adsorbers consult the factory.

With Polycarbonate Bowl

	kPa	PSIG	bar
Operating Pressure Maximum	1000	150	10.3
Operating Temperature Maximum:	52°C (125°F)		

With Metal Bowl

	kPa	PSIG	bar
Operating Pressure Maximum	1700	250	17.0
Operating Temperature Maximum:	80°C (175°F)		

ANSI Symbol

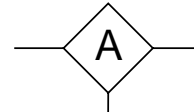

Installation

1. The equipment to which the filter is attached should be internally cleaned to remove all traces of accumulated oil and dirt. Also, new pipe or hose should be installed between the filter and equipment being protected.
2. Blow all upstream pipe work clear of accumulated dirt and liquids.
3. A standard particle filter and a coalescing filter should be installed upstream of adsorber for best results.
4. Select a location as close as possible to the equipment being protected and upstream of any pressure regulator.
5. Install filter so that air flows in the direction of arrow on body.
6. Install filter vertically with the bowl drain mechanism at the bottom.

 **WARNING**

FAILURE OR IMPROPER SELECTION OR IMPROPER USE OF THE PRODUCTS AND/OR SYSTEMS DESCRIBED HEREIN OR RELATED ITEMS CAN CAUSE DEATH, PERSONAL INJURY AND PROPERTY DAMAGE.

This document and other information from The Company, its subsidiaries and authorized distributors provide product and/or system options for further investigation by users having technical expertise. It is important that you analyze all aspects of your application, including consequences of any failure and review the information concerning the product or systems in the current product catalog. Due to the variety of operating conditions and applications for these products or systems, the user, through its own analysis and testing, is solely responsible for making the final selection of the products and systems and assuring that all performance, safety and warning requirements of the application are met.

The products described herein, including without limitation, product features, specifications, designs, availability and pricing, are subject to change by The Company and its subsidiaries at any time without notice.

EXTRA COPIES OF THESE INSTRUCTIONS ARE AVAILABLE FOR INCLUSION IN EQUIPMENT / MAINTENANCE MANUALS THAT UTILIZE THESE PRODUCTS. CONTACT YOUR LOCAL REPRESENTATIVE.

Operation and Service

1. Adsorber elements are designed to adsorb vaporous contaminants. The relative efficiency of an adsorber varies depending on the vapor to be adsorbed and the environmental temperature. At higher temperatures, adsorbers become less efficient.
2. Adsorber cartridges are not particle filters, per se, all particulates and aerosols should be removed prior to adsorbing vaporous contaminants. The initial pressure drop across an adsorber element (1.5 PSID maximum), therefore, should never increase. The presence of any liquids, aerosols, or particulate matter in an adsorber indicates that the effective life of the element has been exceeded and the element should be replaced and the system cleaned.
3. The most effective method of testing whether an element needs to be replaced or not is to smell the air coming from the adsorber. Offensive odors will be present well before oil levels become detectable.
4. To replace the adsorber element:
 - a. **SHUT OFF THE AIR SUPPLY and depressurize the unit.**
 - b. Unscrew the bowl from the filter body.
 - c. Unscrew the adsorber element.
 - d. If contaminants have migrated downstream from the prefilters: clean the adsorber bowl, the air lines from the prefilters to the adsorber, the prefilter bowls and replace the prefilter elements.
 - e. Install the new adsorber element.
 - f. Replace the bowl seal; lubricate the seal sparingly to assist in retaining it in position. Use only mineral based oils or grease. Do NOT use synthetic oils such as esters and Do NOT use silicones.
 - g. Screw bowl into body.
 - h. Apply pressure to the system and check for leaks. If leaks occur, shut off the air supply, depressurize the system and make adjustments necessary to eliminate leakage.

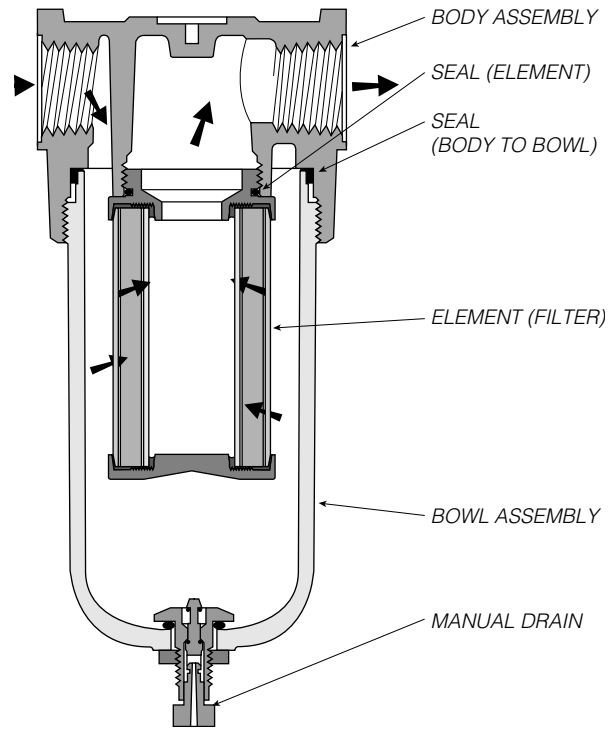

Replacement Adsorber Element Kits

Model	Kit Number
06F	PS156P
07F	PS256P

⚠ WARNING

To avoid unpredictable system behavior that can cause personal injury and property damage:

- **Disconnect electrical supply (when necessary) before installation, servicing, or conversion.**
- **Disconnect air supply and depressurize all air lines connected to this product before installation, servicing, or conversion.**
- **Operate within the manufacturer's specified pressure, temperature, and other conditions listed in these instructions.**
- **Medium must be moisture-free if ambient temperature is below freezing.**
- **Service according to procedures listed in these instructions.**
- **Installation, service, and conversion of these products must be performed by knowledgeable personnel who understand how pneumatic products are to be applied.**
- **After installation, servicing, or conversion, air and electrical supplies (when necessary) should be connected and the product tested for proper function and leakage. If audible leakage is present, or the product does not operate properly, do not put into use.**
- **Warnings and specifications on the product should not be covered by paint, etc. If masking is not possible, contact your local representative for replacement labels.**

2. Blow all upstream pipe work clear of accumulated dirt and liquids.
3. Select a filter location as close as possible to the equipment being protected and upstream of any pressure regulator.
4. Install filter so that air flow is in the direction of the arrow.
5. Install filter vertically with the bowl drain mechanism at the bottom. Free moisture will thus drain into the sump ("quiet zone") at the bottom of the bowl (automatic drain models are recommended as standard equipment).
6. A drain line with 1/8" NPT connection may be attached to the drain port if desired. Drain line should be 1/4" tubing or larger, as short as possible, and crimp-free.

Operation

Both free moisture and solids are removed automatically by the filter. There are no moving parts.

Manual drain filters must be drained regularly before the separated moisture and oil reaches the bottom of the filter element. Automatic drain models will collect and dump the liquid automatically.

Introduction

Follow these instructions when installing, operating, or servicing the product.

Application Limits

These products are intended for use in general purpose compressed air systems only.

Maximum Operating Pressure*:

Inlet Pressure	kPa	PSIG	bar
Metal Bowl	1035	150	10.3

* When using with an Automatic Drain, minimum inlet pressure is 10 PSIG (0.1 bar & 69 kPa).

Maximum Ambient Temperature: 66°C (150°F)

ANSI Symbols

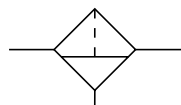

Filter w/Manual Drain

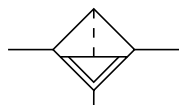

Filter w/Automatic Drain

Installation

1. Filter unit should be installed with reasonable accessibility for service whenever possible - repair service kits are available. Keep pipe or tubing lengths to a minimum with inside clean and free of dirt and chips. Pipe joint compound should be used sparingly and applied only to the male pipe - never into the female port. Do not use PTFE tape to seal pipe joints - pieces could break off from the outlet port and lodge inside units which are located downstream, possibly causing malfunction.

⚠ CAUTION

EXCEPT as otherwise specified by the manufacturer, this product is specifically designed for compressed air service only, and use with any other fluid (liquid or gas) is a misapplication. For example, use with or injection of certain hazardous liquid or gases in the system (such as alcohol or liquid petroleum gas) could be harmful to the unit or result in a combustible condition or hazardous external leakage. Manufacturer's warranties are void in the event of misapplication, and manufacturer assumes no responsibility for any resulting loss.

Before using with fluids other than air, or for nonindustrial applications, or for life support systems, consult manufacturer for written approval.

⚠ WARNING

FAILURE OR IMPROPER SELECTION OR IMPROPER USE OF THE PRODUCTS AND/OR SYSTEMS DESCRIBED HEREIN OR RELATED ITEMS CAN CAUSE DEATH, PERSONAL INJURY AND PROPERTY DAMAGE.

This document and other information from The Company, its subsidiaries and authorized distributors provide product and/or system options for further investigation by users having technical expertise. It is important that you analyze all aspects of your application, including consequences of any failure and review the information concerning the product or systems in the current product catalog. Due to the variety of operating conditions and applications for these products or systems, the user, through its own analysis and testing, is solely responsible for making the final selection of the products and systems and assuring that all performance, safety and warning requirements of the application are met.

The products described herein, including without limitation, product features, specifications, designs, availability and pricing, are subject to change by The Company and its subsidiaries at any time without notice.

EXTRA COPIES OF THESE INSTRUCTIONS ARE AVAILABLE FOR INCLUSION IN EQUIPMENT / MAINTENANCE MANUALS THAT UTILIZE THESE PRODUCTS. CONTACT YOUR LOCAL REPRESENTATIVE.

Maintenance Procedures

⚠ Caution: Shut off air supply and exhaust the pressure trapped within the filter bowl before servicing unit.

1. TO CLEAN OR REPLACE FILTER ELEMENT – Shut off air supply and reduce pressure in the unit to zero, remove the 8 screws from the filter housing, unscrew the filter support and remove filter element.
 - 1a. IF THE UNIT HAS A RIGID FILTER ELEMENT – Remove and clean periodically by tapping on a hard surface, and blowing off with an air gun. Torque element to 50 ± 5 in. lb. when replacing element. Element should be cleaned/replaced when the Differential Pressure Indicator is completely red.
2. IF THE UNIT HAS A MANUAL DRAIN, DRAIN THE UNIT ONCE EVERY 8 HOURS MINIMUM. If the unit is equipped with an automatic drain, clean the screen around the drain. Clean screen by blowing off with air gun.
3. When the bowl becomes dirty, clean with a dry clean cloth.
4. Before placing the unit in service, make sure that the bowl is properly reinstalled, and securely bolted in place.

Kits and Parts Available

<u>Kit No.</u>	<u>Description</u>
PS618	Filter Element Kit (includes filter element and o-rings)
PS619	Differential Pressure Indicator (Standard)
PS620	Internal Drains: Automatic Mechanical Drain (Fluorocarbon seals with 1/8" NPT stem)

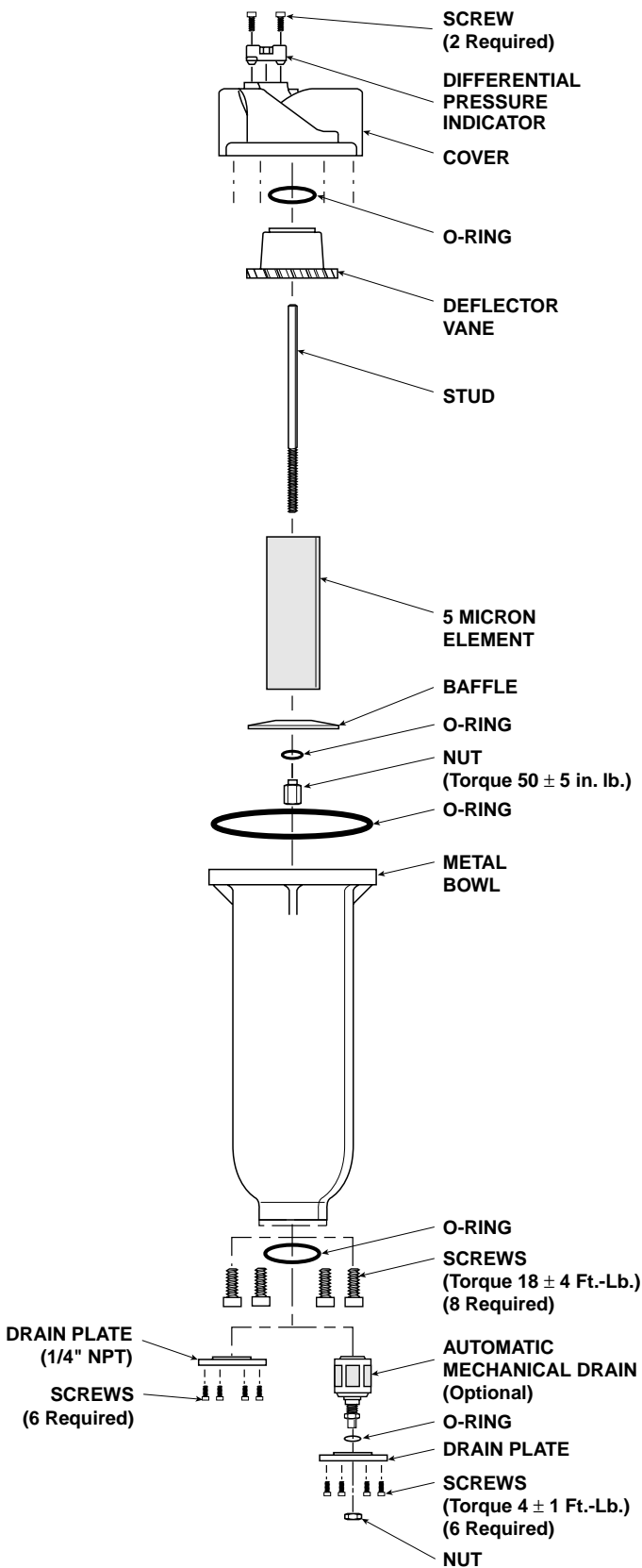

FOR USE WITH FILTERS, LUBRICATORS AND FILTER / REGULATORS

⚠ WARNING

To avoid unpredictable system behavior that can cause personal injury and property damage:

- Disconnect electrical supply (when necessary) before installation, servicing, or conversion.
- Disconnect air supply and depressurize all air lines connected to this product before installation, servicing, or conversion.
- Operate within the manufacturer's specified pressure, temperature, and other conditions listed in these instructions.
- Medium must be moisture-free if ambient temperature is below freezing.
- Service according to procedures listed in these instructions.
- Installation, service, and conversion of these products must be performed by knowledgeable personnel who understand how pneumatic products are to be applied.
- After installation, servicing, or conversion, air and electrical supplies (when necessary) should be connected and the product tested for proper function and leakage. If audible leakage is present, or the product does not operate properly, do not put into use.
- Warnings and specifications on the product should not be covered by paint, etc. If masking is not possible, contact your local representative for replacement labels.

Introduction

Follow these instructions when installing, operating, or servicing the product.

Application Limits

These products are intended for use in general purpose compressed air systems only. Pressure and temperature ranges for bowls are given below. Specific units may differ; follow applicable ranges as specified for the units you are servicing. Consult the instruction sheet which came with the unit for more details.

Bowl Pressure & Ambient Temperature Ranges

Polycarbonate Bowls:

0 to 150 PSIG (0 to 1,030 kPa)
32°F to 125°F (0°C to 52°C)

Metal Bowls:

0 to 250 PSIG (0 to 1,720 kPa)
32°F to 175°F (0°C to 80°C)

Servicing Bowls & Sight Gauges

1. Turn off air supply and depressurize the unit before removing any parts.

⚠ Caution: Be certain that pressure is relieved on both sides of any regulator in a system.

2. Lubricators with auto fill devices require oil system shut-off and disconnection. Filters with automatic drains require disconnection.
3. Unscrew bowl until its threads are completely disengaged.
4. Remove the old parts and clean the bowl and *sight gauge*, especially their respective sealing surfaces. Fit the large o-ring into the sight gauge groove such that the gripping

nibs in the groove hold the o-ring in place. Then place the sight gauge in position and add the screws and their sealing o-rings. Secure gauge to bowl using 12 to 16 in-lbs (1.4 to 1.8 Nm) of torque.

5. Remove the *body to bowl seal* and thoroughly clean the sealing surface in the body. Also check for damage in the sealing area and threads. Replace the entire unit if this condition exists.
6. Place the new seal onto the end of the bowl or into the groove/edge of the body. The choice of location depends on the design of the parts. If the bowl has a slight retaining ridge on the groove edge, put the new seal onto the bowl. If the body has a slight recess above the threads, put the seal into that groove, dry. If neither of these conditions are present, the seal should be placed dry onto the body ledge above the threads.
7. Lubricate the edge of the bowl where it will contact the seal before reinstalling.

Note: Use only mineral based oils or grease (a package is supplied with kits); do not use synthetic lubricants such as esters and do not use silicone lubricants.

8. Screw the bowl into the body until it reaches a positive stop; then reverse it about 1/8 turn. Metal bowls with sight gauges can be reversed about 3/4 turn to position the sight gauge as desired.

⚠ Caution: Inlet pressure ratings for Polycarbonate bowls are less than those for metal bowls. If replacing a metal bowl with a Polycarbonate bowl, affix "Max Inlet" label provided over similar label on body.

9. Pressurize the assembled unit and check for leaks. If any occur, turn off the air supply, de-pressurize the system and fix the leak before resuming operation.

⚠ WARNING

FAILURE OR IMPROPER SELECTION OR IMPROPER USE OF THE PRODUCTS AND/OR SYSTEMS DESCRIBED HEREIN OR RELATED ITEMS CAN CAUSE DEATH, PERSONAL INJURY AND PROPERTY DAMAGE.

This document and other information from The Company, its subsidiaries and authorized distributors provide product and/or system options for further investigation by users having technical expertise. It is important that you analyze all aspects of your application, including consequences of any failure and review the information concerning the product or systems in the current product catalog. Due to the variety of operating conditions and applications for these products or systems, the user, through its own analysis and testing, is solely responsible for making the final selection of the products and systems and assuring that all performance, safety and warning requirements of the application are met.

The products described herein, including without limitation, product features, specifications, designs, availability and pricing, are subject to change by The Company and its subsidiaries at any time without notice.

EXTRA COPIES OF THESE INSTRUCTIONS ARE AVAILABLE FOR INCLUSION IN EQUIPMENT / MAINTENANCE MANUALS THAT UTILIZE THESE PRODUCTS. CONTACT YOUR LOCAL REPRESENTATIVE.

Servicing Manual Drains

1. Removing Bowl and Old Drain

- a. Turn off air supply and de-pressurize the unit.

⚠ Caution: Be certain that pressure is relieved on both sides of any regulator in a system.

- b. Unscrew threaded bowl.
- c. Remove manual drain assembly from bowl. Be careful not to scratch or damage the inside surface of the bowl.

2. Installing New Manual Drain

Note: Clean the bowl before installing manual drain and reassembling the bowl to the body. See cleaning of bowls in the *Safety: Transparent Bowls* section.

a. Installation of PS512 drain kit:

Install manual drain body through the bowl opening with the threads protruding downwards and the o-ring seals on the inside of the bowl. Then assemble drain nut and tighten it from 10 to 15 in-lbs (1.1 to 1.7 Nm) of torque.

b. Installation of PS513 drain kit:

Install Push-N-Drain by pushing through the bowl opening so that the raised bead of the drain assembly seals on the inside of the bowl.

3. Installing bowl and Leak Testing:

- a. Screw the bowl into the body until it reaches a positive stop; then reverse it about 1/8 turn. Metal bowls with sight gauges can be reversed about 3/4 turn to position the sight gauge as desired.
- b. Apply system pressure; then check for air leaks. If leaks occur, shut off the air supply, depressurize the system and make necessary adjustments to eliminate leakage.

If you have questions concerning how to service these units, contact your local authorized dealer or your customer service representative.

Safety: Transparent Bowls

⚠ CAUTION

Polycarbonate bowls, being transparent and tough, are ideal for use with Filters and Lubricators. They are suitable for use in normal industrial environments, but should not be located in areas where they could be subjected to direct sunlight, an impact blow, nor temperatures outside of the rated range. As with most plastics, some chemicals can cause damage. Polycarbonate bowls should not be exposed to chlorinated hydro-carbons, ketones, esters, and certain alcohols. They should not be used in air systems where compressors are lubricated with fire resistant fluids such as phosphate ester and di-ester types.

Metal bowls are recommended where ambient and/or media conditions are not compatible with polycarbonate bowls. Metal bowls resist the action of most such solvents, but should not be used where strong acids or bases are present or in salt laden atmospheres. Consult the factory for specific recommendations where these conditions exist.

TO CLEAN POLYCARBONATE BOWLS USE MILD SOAP AND WATER ONLY! DO NOT use cleaning agents such as acetone, benzene, carbon tetrachloride, gasoline, toluene, etc., which are damaging to this plastic.

Bowl guards are recommended for added protection of polycarbonate bowls where chemical attack may occur.

⚠ WARNING

To avoid polycarbonate bowl rupture that can cause personal injury or property damage, do not exceed bowl pressure or temperature ratings. Polycarbonate bowls have a 150 psig (1030 kPa) pressure rating and a maximum temperature rating of 125°F (52°C).

Service Kits Available

Twist Drain Kit	PS512
Push-N-Drain	PS513

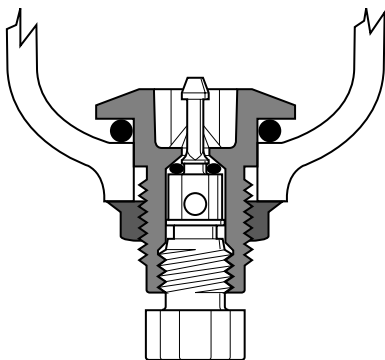

PS512

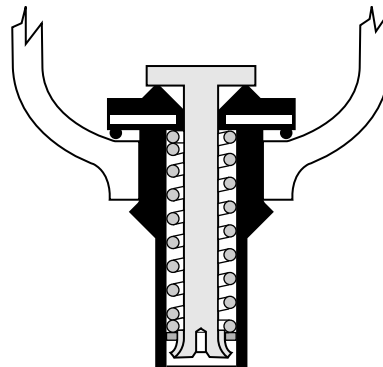

PS513

 **WARNING**

To avoid unpredictable system behavior that can cause personal injury and property damage:

- Disconnect electrical supply (when necessary) before installation, servicing, or conversion.
- Disconnect air supply and depressurize all air lines connected to this product before installation, servicing, or conversion.
- Operate within the manufacturer's specified pressure, temperature, and other conditions listed in these instructions.
- Medium must be moisture-free if ambient temperature is below freezing.
- Service according to procedures listed in these instructions.
- Installation, service, and conversion of these products must be performed by knowledgeable personnel who understand how pneumatic products are to be applied.
- After installation, servicing, or conversion, air and electrical supplies (when necessary) should be connected and the product tested for proper function and leakage. If audible leakage is present, or the product does not operate properly, do not put into use.
- Warnings and specifications on the product should not be covered by paint, etc. If masking is not possible, contact your local representative for replacement labels.

Safety: Transparent Bowls

 **CAUTION**

Polycarbonate bowls, being transparent and tough, are ideal for use with Filters and Lubricators. They are suitable for use in normal industrial environments, but should not be located in areas where they could be subjected to direct sunlight, an impact blow, nor temperatures outside of the rated range. As with most plastics, some chemicals can cause damage. Polycarbonate bowls should not be exposed to chlorinated hydro-carbons, ketones, esters, and certain alcohols. They should not be used in air systems where compressors are lubricated with fire resistant fluids such as phosphate ester and di-ester types.

Metal bowls are recommended where ambient and/or media conditions are not compatible with polycarbonate bowls. Metal bowls resist the action of most such solvents, but should not be used where strong acids or bases are present or in salt laden atmospheres. Consult the factory for specific recommendations where these conditions exist.

TO CLEAN POLYCARBONATE BOWLS USE MILD SOAP AND WATER ONLY! DO NOT use cleaning agents such as acetone, benzene, carbon tetrachloride, gasoline, toluene, etc., which are damaging to this plastic.

Bowl guards are recommended for added protection of polycarbonate bowls where chemical attack may occur.

 **WARNING**

To avoid polycarbonate bowl rupture that can cause personal injury or property damage, do not exceed bowl pressure or temperature ratings. Polycarbonate bowls have a 150 psig (1030 kPa) pressure rating and a maximum temperature rating of 125°F (52°C).

Introduction

Follow these instructions when installing, operating, or servicing the product.

Application Limits

These products are intended for use in general purpose compressed air systems only.

Operating Pressure	kPa	PSIG	bar
Maximum Inlet	800	120	8

Temperature Range (Ambient)
 32°F to 125°F (0°C to 52°C)

 **WARNING**

FAILURE OR IMPROPER SELECTION OR IMPROPER USE OF THE PRODUCTS AND/OR SYSTEMS DESCRIBED HEREIN OR RELATED ITEMS CAN CAUSE DEATH, PERSONAL INJURY AND PROPERTY DAMAGE.

This document and other information from The Company, its subsidiaries and authorized distributors provide product and/or system options for further investigation by users having technical expertise. It is important that you analyze all aspects of your application, including consequences of any failure and review the information concerning the product or systems in the current product catalog. Due to the variety of operating conditions and applications for these products or systems, the user, through its own analysis and testing, is solely responsible for making the final selection of the products and systems and assuring that all performance, safety and warning requirements of the application are met.

The products described herein, including without limitation, product features, specifications, designs, availability and pricing, are subject to change by The Company and its subsidiaries at any time without notice.

EXTRA COPIES OF THESE INSTRUCTIONS ARE AVAILABLE FOR INCLUSION IN EQUIPMENT / MAINTENANCE MANUALS THAT UTILIZE THESE PRODUCTS. CONTACT YOUR LOCAL REPRESENTATIVE.

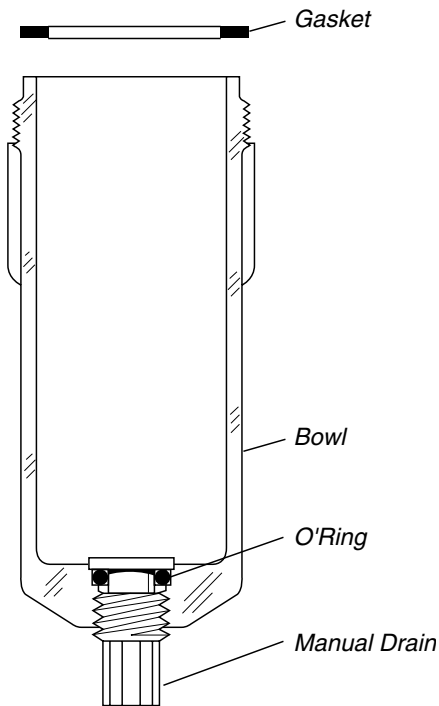
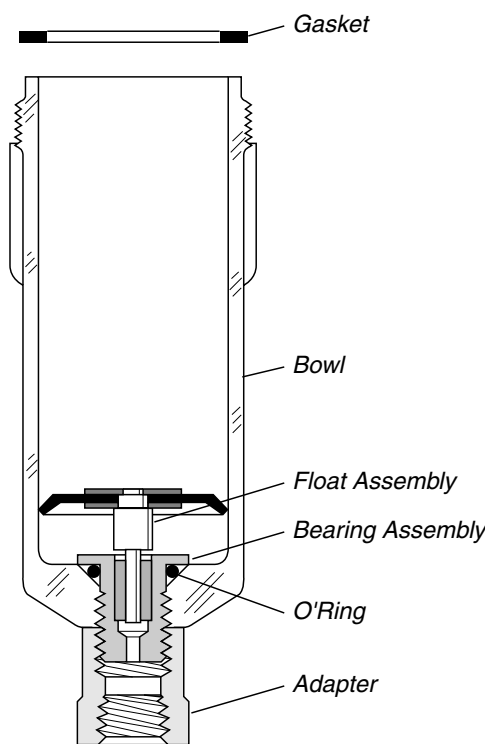
**Manual Drain****Auto Drain**

Servicing

1. To remove the bowl assembly: SHUT OFF AIR SUPPLY and depressurize the unit.
2. Unscrew threaded bowl.
3. Replace the bowl gasket, lubricate gasket to assist in retaining it in position. Use only mineral base oils or grease. Do NOT use synthetic oils such as esters and do NOT use silicones.
4. To replace the lubricator bowl, fill to fill line on the bowl (DO NOT OVERFILL) with oil of 100 to 200 SSU viscosity at 100°F and an aniline point greater than 200°F – same as SAE No. 10 (petroleum base hydraulic oils are good examples). DO NOT USE OILS WITH ADHESIVES OR TACKY ADDITIVES. COMPOUNDED OILS CONTAINING SOLVENTS, GRAPHITE, SOAPS, OR DETERGENTS (automotive oils generally contain detergents) ARE NOT RECOMMENDED.
5. Screw bowl into body and tighten firmly.
6. Repressurize the unit.

⚠ WARNING

To avoid unpredictable system behavior that can cause personal injury and property damage:

- Disconnect electrical supply (when necessary) before installation, servicing, or conversion.
- Disconnect air supply and depressurize all air lines connected to this product before installation, servicing, or conversion.
- Operate within the manufacturer's specified pressure, temperature, and other conditions listed in these instructions.
- Medium must be moisture-free if ambient temperature is below freezing.
- Service according to procedures listed in these instructions.
- Installation, service, and conversion of these products must be performed by knowledgeable personnel who understand how pneumatic products are to be applied.
- After installation, servicing, or conversion, air and electrical supplies (when necessary) should be connected and the product tested for proper function and leakage. If audible leakage is present, or the product does not operate properly, do not put into use.
- Warnings and specifications on the product should not be covered by paint, etc. If masking is not possible, contact your local representative for replacement labels.

⚠ CAUTION

Polycarbonate bowls, being transparent and tough, are ideal for use with Filters and Lubricators. They are suitable for use in normal industrial environments, but should not be located in areas where they could be subjected to direct sunlight, an impact blow, nor temperatures outside of the rated range. As with most plastics, some chemicals can cause damage. Polycarbonate bowls should not be exposed to chlorinated hydrocarbons, ketones, esters and certain alcohols. They should not be used in air systems where compressors are lubricated with fire-resistant fluids such as phosphate ester and diester types.

Metal bowls are recommended where ambient and/or media conditions are not compatible with polycarbonate bowls. Metal bowls resist the action of most such solvents, but should not be used where strong acids or bases are present or in salt laden atmospheres. Consult the factory for specific recommendations where these conditions exist.

TO CLEAN POLYCARBONATE BOWLS USE MILD SOAP AND WATER ONLY! DO NOT use cleansing agents such as acetone, benzene, carbon tetrachloride, gasoline, toluene, etc., which are damaging to this plastic.

Bowl guards are recommended for added protection of polycarbonate bowls where chemical attack may occasionally occur.

Introduction

Follow these instructions when installing, operating, or servicing the product.

Application Limits

These products are intended for use in general purpose compressed air systems only.

With Polycarbonate Bowl

	kPa	PSIG	bar
Operating Pressure Maximum	830	120	8.3
Operating Temperature Maximum:	52°C (125°F)		

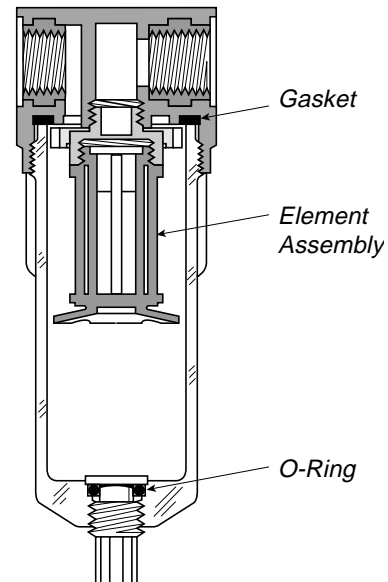

Installation

1. The equipment to which the filter is attached should be internally cleaned to remove all traces of accumulated oil and dirt. Also, new pipe or hose should be installed between the filter and equipment being protected.
2. Blow all upstream pipe work clear of accumulated dirt and liquids.
3. Select a filter location as close as possible to the equipment being protected and upstream of any pressure regulator.
4. Install filter so that air flows in the direction of arrow on body.
5. Install filter vertically with bowl drain mechanism at the bottom. Free moisture will thus drain into the sump "quiet zone" at the bottom of the bowl (automatic drain models are recommended as standard equipment).

⚠ WARNING

FAILURE OR IMPROPER SELECTION OR IMPROPER USE OF THE PRODUCTS AND/OR SYSTEMS DESCRIBED HEREIN OR RELATED ITEMS CAN CAUSE DEATH, PERSONAL INJURY AND PROPERTY DAMAGE.

This document and other information from The Company, its subsidiaries and authorized distributors provide product and/or system options for further investigation by users having technical expertise. It is important that you analyze all aspects of your application, including consequences of any failure and review the information concerning the product or systems in the current product catalog. Due to the variety of operating conditions and applications for these products or systems, the user, through its own analysis and testing, is solely responsible for making the final selection of the products and systems and assuring that all performance, safety and warning requirements of the application are met.

The products described herein, including without limitation, product features, specifications, designs, availability and pricing, are subject to change by The Company and its subsidiaries at any time without notice.

EXTRA COPIES OF THESE INSTRUCTIONS ARE AVAILABLE FOR INCLUSION IN EQUIPMENT / MAINTENANCE MANUALS THAT UTILIZE THESE PRODUCTS. CONTACT YOUR LOCAL REPRESENTATIVE.

Operation & Service

1. Both free moisture and solids are removed automatically by the filter. There are no moving parts.
2. Manual drain filters must be drained regularly before the separated moisture and oil reaches the bottom of the lower baffle. Automatic drain models will collect and dump liquids automatically.
3. The filter element should be removed and replaced when the pressure differential across the filter is 10 PSIG.
4. To remove the filter element: SHUT OFF AIR SUPPLY and depressurize the unit.
 - a. Unscrew threaded bowl.
 - b. Unscrew element assembly.
 - c. Clean bowl and internal parts before cleaning reassembling. See polycarbonate bowl cleaning section.
 - d. Attach clean element assembly and tighten firmly.
 - e. Replace bowl gasket; lubricate gasket to assist in retaining it in position. Use only mineral base oils or grease. Do NOT use synthetic oils such as esters, and do NOT use silicones.
 - f. Screw bowl into body and tighten firmly.

Kits Available

<u>Kit No.</u>	<u>Description</u>
P3A-KA00EEN	Element Kit
P3A-KA00RFN	Filter Repair Kit

⚠ WARNING

To avoid unpredictable system behavior that can cause personal injury and property damage:

- **Disconnect electrical supply (when necessary) before installation, servicing, or conversion.**
- **Disconnect air supply and depressurize all air lines connected to this product before installation, servicing, or conversion.**
- **Operate within the manufacturer's specified pressure, temperature, and other conditions listed in these instructions.**
- **Medium must be moisture-free if ambient temperature is below freezing.**
- **Service according to procedures listed in these instructions.**
- **Installation, service, and conversion of these products must be performed by knowledgeable personnel who understand how pneumatic products are to be applied.**
- **After installation, servicing, or conversion, air and electrical supplies (when necessary) should be connected and the product tested for proper function and leakage. If audible leakage is present, or the product does not operate properly, do not put into use.**
- **Warnings and specifications on the product should not be covered by paint, etc. If masking is not possible, contact your local representative for replacement labels.**

Introduction

Follow these instructions when installing, operating, or servicing the product.

Application Limits

These products are intended for use in general purpose compressed air systems only.

Operating Inlet Pressure:

	kPa	PSIG	bar
with Polycarbonate Bowl	1000	150	10.3
with Metal Bowl	1700	250	17.0

NOTE: The maximum recommended pressure drop for a particulate filter is 70 kPa (10 psig, 0.7 bar)

Ambient Temperature Range:

with Polycarbonate Bowl	0°C to 52°C (32°F to 125°F)
with Metal Bowl	0°C to 80°C (32°F to 175°F)

Symbols

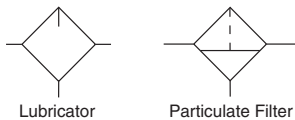

Mist Lubricators (Figure 1)

Description

These mist lubricators are designed to deliver an atomized oil mist to air operated tools, motors, and other pneumatic equipment. Units are equipped with full-view sight glass for visual indication of oil drop rate, needle valve feed adjustment to regulate oil drop rate, and a venturi bypass disc to compensate for changes in air flow demands.

Installation of Lubricator

1. Lubricator should be installed with reasonable accessibility for service whenever possible - repair service kits are available. Keep pipe and tubing lengths to a minimum with inside clean and free of dirt and chips. Pipe joint compounds should be used sparingly and applied only to the male pipe – never into the female port. Do not use PTFE tape to seal pipe joints - pieces have a tendency to break off and lodge inside the unit, possibly causing malfunction.

2. Install lubricator so that air flow is in the direction of arrow on body.
3. Installation should be upstream from, and as close as possible, to the device it is to lubricate (valve, cylinder, tool, etc.). Whenever possible, avoid locations that require air-borne oil to move in an upward direction to reach the device to be lubricated.
4. The installation of an individual lubricator for each air consuming device provides best assurances of proper lubrication.
5. In new installations, it is good practice to “wet down” the inside diameter of piping and/hose with oil before making final connections. Although your lubricator delivers oil to the line, pre-coating the inside diameter with oil helps insure that proper amounts of oil are delivered to the point of application.

Operation & Service of Lubricator

⚠ Warning: Before filling, inlet pressure must be eliminated and then de-pressurize system pressure.

1. **FILLING** - After de-pressurizing system, remove bowl to refill lubricator. Fill bowl to fill line indicated on the bowl with oil of 150 to 200 SSU at 100°F viscosity - same as SAE No. 10 (petroleum based hydraulic oils or spindle oils are good examples). **DO NOT USE OILS WITH TACKY ADDITIVES, COMPOUND OILS CONTAINING SOLVENTS, GRAPHITE, SOAPS OR DETERGENTS.** (Automotive oils generally contain detergents and are not recommended).
2. Replace the bowl and seat firmly. Excessive torque is not necessary. The lubricator is now ready for setting.
3. **OIL DELIVERY ADJUSTMENT** - To adjust oil delivery, turn the adjusting needle on top of the lubricator.

Leaner - Clockwise Richer - Counterclockwise

By counting the number of drops per minute in the sight dome, you can adjust lubricator to your required setting.

Generally, one drop per minute downstream for every 10-15 SCFM flow is satisfactory. 25 drops per minute equals one ounce per hour - volume of oil passing through the sight dome.

NOTE: This is a constant density type lubricator which delivers a constant ratio of oil to air flow. Therefore, if air flow increases or decreases, oil delivery will be effected proportionately. **ONLY IF DIFFERENT RATIO IS DESIRED SHOULD YOUR ADJUSTMENT KNOB SETTING BE CHANGED AFTER YOUR INITIAL SETTING.**

⚠ WARNING

FAILURE OR IMPROPER SELECTION OR IMPROPER USE OF THE PRODUCTS AND/OR SYSTEMS DESCRIBED HEREIN OR RELATED ITEMS CAN CAUSE DEATH, PERSONAL INJURY AND PROPERTY DAMAGE.

This document and other information from The Company, its subsidiaries and authorized distributors provide product and/or system options for further investigation by users having technical expertise. It is important that you analyze all aspects of your application, including consequences of any failure and review the information concerning the product or systems in the current product catalog. Due to the variety of operating conditions and applications for these products or systems, the user, through its own analysis and testing, is solely responsible for making the final selection of the products and systems and assuring that all performance, safety and warning requirements of the application are met.

The products described herein, including without limitation, product features, specifications, designs, availability and pricing, are subject to change by The Company and its subsidiaries at any time without notice.

EXTRA COPIES OF THESE INSTRUCTIONS ARE AVAILABLE FOR INCLUSION IN EQUIPMENT / MAINTENANCE MANUALS THAT UTILIZE THESE PRODUCTS. CONTACT YOUR LOCAL REPRESENTATIVE.

Service Kits - Lubricator

Kit#	Description
PS420	Polycarbonate Bowl with Manual Drain - consists of items: 18 (open bottom), 15, 16, 17 & 32
PS421	Polycarbonate Bowl without Drain - consists of items: 18 (closed bottom) & 15
PS474	Drip Control (Polycarbonate)
PS475	Drip Control (Nylon)

Parts Identification List - Lubricator

Item#	Description	Item#	Description
1	Knob	11	Spring
2	Drip Control Body	12	Ball, Check
3	Needle	13	Body
4	O-ring	14	Tube
5	Drip Tube	15	O-ring (Body to Bowl)
6	Seal Plate	16	Twist Drain
7	O-ring	17	O-ring (Drain)
8	By-pass Plate	18	Bowl
9	By-pass	32	Twist Drain Knob
10	Ball, Check		

Particulate Filter (Figure 2)

Description

These air line filters are heavy-duty units used to remove airborne impurities from air supply lines by means of centrifugal force and filter element. Units are equipped with vane-type deflectors and drain valves. Deflector plate creates swirling action to the air stream assuring entrainments separation at all flow rates. Filter element with extra large surface assures fine filtration with low pressure drop. Turn manual drain clockwise to open and counterclockwise to close.

Installation of Filter

- Filter should be installed with reasonable accessibility for service whenever possible - repair service kits are available. Keep pipe and tubing lengths to a minimum with inside clean and free of dirt and chips. Pipe joint compounds should be used sparingly and applied only to the male pipe - never into the female port. Do not use PTFE tape to seal pipe joints - pieces have a tendency to break off and lodge inside the unit, possibly causing malfunction.
- Install unit so that air flow is in the direction of arrow. Installation must be upstream of and close to devices it is to service (valve, cylinder, tool, etc.). Position unit vertically with the bowl drain mechanism at the bottom. Free moisture will thus drain into the sump ("quiet zone") at the bottom of the bowl.

Operation of the Filter

- Both free moisture and solids are removed automatically by the filter.
- Manual drain filters must be drained regularly before the separated moisture and oil reaches the bottom of the element holder. Automatic drain models (pulse drain) will collect and dump liquids automatically. They are actuated when a pressure drop occurs within the filter.
- The filter element should be removed and replaced when the pressure differential across the filter exceeds 70 kPa (10 psig, 0.7 bar).

Service

⚠ Caution: SHUT OFF AIR SUPPLY and exhaust the primary and secondary pressure before dis-assembling unit. (Units may be serviced without removing them from the air line.)

Servicing Filter Element

- Unscrew threaded bowl and element holder. Then remove filter element, deflector, and gaskets.
- Clean all internal parts, bowl, and body before re-assembling unit. See Polycarbonate bowl cleaning section.
- Install deflector, filter element, and gaskets.
- Attach element holder. Torque from 0.9 to 1.4 Nm (8 to 12 in-lbs).
- To assist with retaining bowl's o-ring while installing bowl, lubricate the o-ring (with a mineral based oil or grease). Then place on the bowl.
- Screw bowl into the body until it is stopped by body; then back off bowl 1/8 turn.
- Apply pressure to the system and check for leaks. If leaks occur, shut off the air supply, de-pressurize the system and make necessary adjustments to eliminate leakage.

If you have questions concerning how to service this unit, contact your local dealer or your customer service representative.

Service Kits- Filter

Kit#	Description
PS404	Polycarbonate Bowl with Manual Drain - consists of items: 19, 24, 26 & 27
PS408	Polycarbonate Bowl with Automatic Drain - consists of items: 19, 24, 26, 28, 29, 30 & 31
PS447B	Metal Bowl with Manual Drain - consists of items: 19, 24, 26 & 27
PS451	Metal Bowl with Automatic Drain - consists of items: 19, 24, 26, 28, 29, 30 & 31
PS403	5 Micrometer Element Kit - consists of items: 20, 21 & 24
PS407	5 Micrometer Element Cartridge Kit - consists of items: 20, 21, 22, 23 & 24
PS401	40 Micrometer Element Kit - consists of items: 20, 21 & 24

Parts Identification List - Filter Units

Item#	Description	Item#	Description
19	Bowl	27	Manual Drain (twist style)
20	Gasket	28	O-ring - pulse drain
21	Filter Element	29	Drain (body of pulse drain shown)
22	Filter Holder		
23	Deflector	30	Diaphragm
24	O-ring (body to bowl)	31	Pin
25	Body	32	Twist Drain Knob
26	O-ring (drain to bowl)		

Safety: Transparent Bowls

⚠ CAUTION

Polycarbonate bowls, being transparent and tough, are ideal for use with Filters and Lubricators. They are suitable for use in normal industrial environments, but should not be located in areas where they could be subjected to direct sunlight, an impact blow, nor temperatures outside of the rated range. As with most plastics, some chemicals can cause damage. Polycarbonate bowls should not be exposed to chlorinated hydrocarbons, ketones, esters and certain alcohols. They should not be used in air systems where compressors are lubricated with fire-resistant fluids such as phosphate ester and diester types.

Metal bowls are recommended where ambient and/or media conditions are not compatible with polycarbonate bowls. Metal bowls resist the action of most such solvents, but should not be used where strong acids or bases are present or in salt laden atmospheres. Consult the factory for specific recommendations where these conditions exist.

TO CLEAN POLYCARBONATE BOWLS USE MILD SOAP AND WATER ONLY! DO NOT use cleansing agents such as acetone, benzene, carbon tetrachloride, gasoline, toluene, etc., which are damaging to this plastic.

⚠ WARNING

To avoid polycarbonate bowl rupture that can cause personal injury or property damage, do not exceed bowl pressure or temperature ratings. Polycarbonate bowls have a 150 PSIG pressure rating and a maximum temperature rating of 125°F.

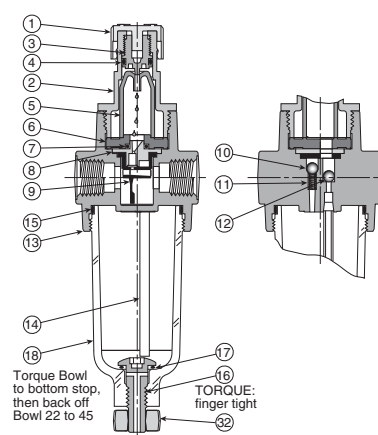

Figure 1: Mist Lubricator

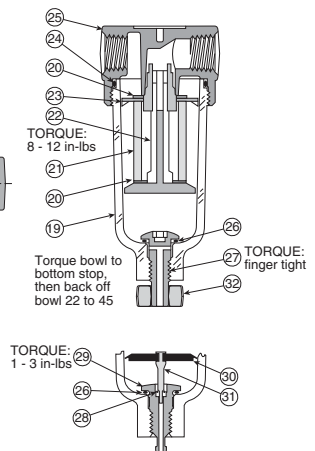

Figure 2: Particulate Filter

Pneumatic Division
 Richland, Michigan 49083
 269-629-5000

Installation and Service Instructions:
2F101H
 1/4" & 3/8" Economy
 1/4", 3/8" & 1/2" Compact
 1/2" & 3/4" Standard
 Particulate and Adsorber
ISSUED: September, 2012
Supersedes: September, 2006
 Doc.# 2F101, EN# 120039, Rev. 14

⚠ WARNING

To avoid unpredictable system behavior that can cause personal injury and property damage:

- Disconnect electrical supply (when necessary) before installation, servicing, or conversion.
- Disconnect air supply and depressurize all air lines connected to this product before installation, servicing, or conversion.
- Operate within the manufacturer's specified pressure, temperature, and other conditions listed in these instructions.
- Medium must be moisture-free if ambient temperature is below freezing.
- Service according to procedures listed in these instructions.
- Installation, service, and conversion of these products must be performed by knowledgeable personnel who understand how pneumatic products are to be applied.
- After installation, servicing, or conversion, air and electrical supplies (when necessary) should be connected and the product tested for proper function and leakage. If audible leakage is present, or the product does not operate properly, do not put into use.
- Warnings and specifications on the product should not be covered by paint, etc. If masking is not possible, contact your local representative for replacement labels.

⚠ CAUTION

Polycarbonate bowls, being transparent and tough, are ideal for use with Filters and Lubricators. They are suitable for use in normal industrial environments, but should not be located in areas where they could be subjected to direct sunlight, an impact blow, nor temperatures outside of the rated range. As with most plastics, some chemicals can cause damage. Polycarbonate bowls should not be exposed to chlorinated hydrocarbons, ketones, esters and certain alcohols. They should not be used in air systems where compressors are lubricated with fire-resistant fluids such as phosphate ester and diester types.

Metal bowls are recommended where ambient and/or media conditions are not compatible with polycarbonate bowls. Metal bowls resist the action of most such solvents, but should not be used where strong acids or bases are present or in salt laden atmospheres. Consult the factory for specific recommendations where these conditions exist.

TO CLEAN POLYCARBONATE BOWLS USE MILD SOAP AND WATER ONLY! DO NOT use cleansing agents such as acetone, benzene, carbon tetrachloride, gasoline, toluene, etc., which are damaging to this plastic.

Bowl guards are recommended for added protection of polycarbonate bowls where chemical attack may occasionally occur.

⚠ WARNING

To avoid polycarbonate bowl rupture that can cause personal injury or property damage, do not exceed bowl pressure or temperature ratings. Polycarbonate bowls have a 150 PSIG pressure rating and a maximum temperature rating of 125°F.

Safety Guide

For more complete information on recommended application guidelines, see the Safety Guide section of Pneumatic Division catalogs or you can download the **Pneumatic Division Safety Guide** at: www.parker.com/safety

Introduction

Follow these instructions when installing, operating, or servicing the product.

Application Limits

These products are intended for use in general purpose compressed air systems only.

Adsorber Filters are **not effective** on: Carbon monoxide, carbon dioxide, methane, ethane, ethylene or hydrogen. For a complete list of vapors that can and cannot be adsorbed effectively by activated charcoal adsorbers consult the factory.

Maximum Recommended Pressure Drop:

	kPa	PSIG	bar
Particulate Filter	70	10	0.7

With Polycarbonate Bowl

	kPa	PSIG	bar
Operating Pressure Maximum	1000	150	10.3
Operating Temperature Maximum	52°C (125°F)		
Operating Temperature Minimum	0°C (32°F)		

With Metal Bowl

	kPa	PSIG	bar
Operating Pressure Maximum	1700	250	17.0
Operating Temperature Maximum	80°C (175°F)		
Operating Temperature Minimum	0°C (32°F)		

ANSI Symbols

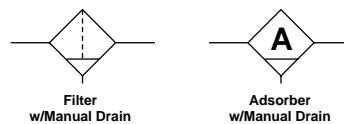

⚠ WARNING

FAILURE OR IMPROPER SELECTION OR IMPROPER USE OF THE PRODUCTS AND/OR SYSTEMS DESCRIBED HEREIN OR RELATED ITEMS CAN CAUSE DEATH, PERSONAL INJURY AND PROPERTY DAMAGE.

This document and other information from The Company, its subsidiaries and authorized distributors provide product and/or system options for further investigation by users having technical expertise. It is important that you analyze all aspects of your application, including consequences of any failure and review the information concerning the product or systems in the current product catalog. Due to the variety of operating conditions and applications for these products or systems, the user, through its own analysis and testing, is solely responsible for making the final selection of the products and systems and assuring that all performance, safety and warning requirements of the application are met.

The products described herein, including without limitation, product features, specifications, designs, availability and pricing, are subject to change by The Company and its subsidiaries at any time without notice.

EXTRA COPIES OF THESE INSTRUCTIONS ARE AVAILABLE FOR INCLUSION IN EQUIPMENT / MAINTENANCE MANUALS THAT UTILIZE THESE PRODUCTS. CONTACT YOUR LOCAL REPRESENTATIVE.

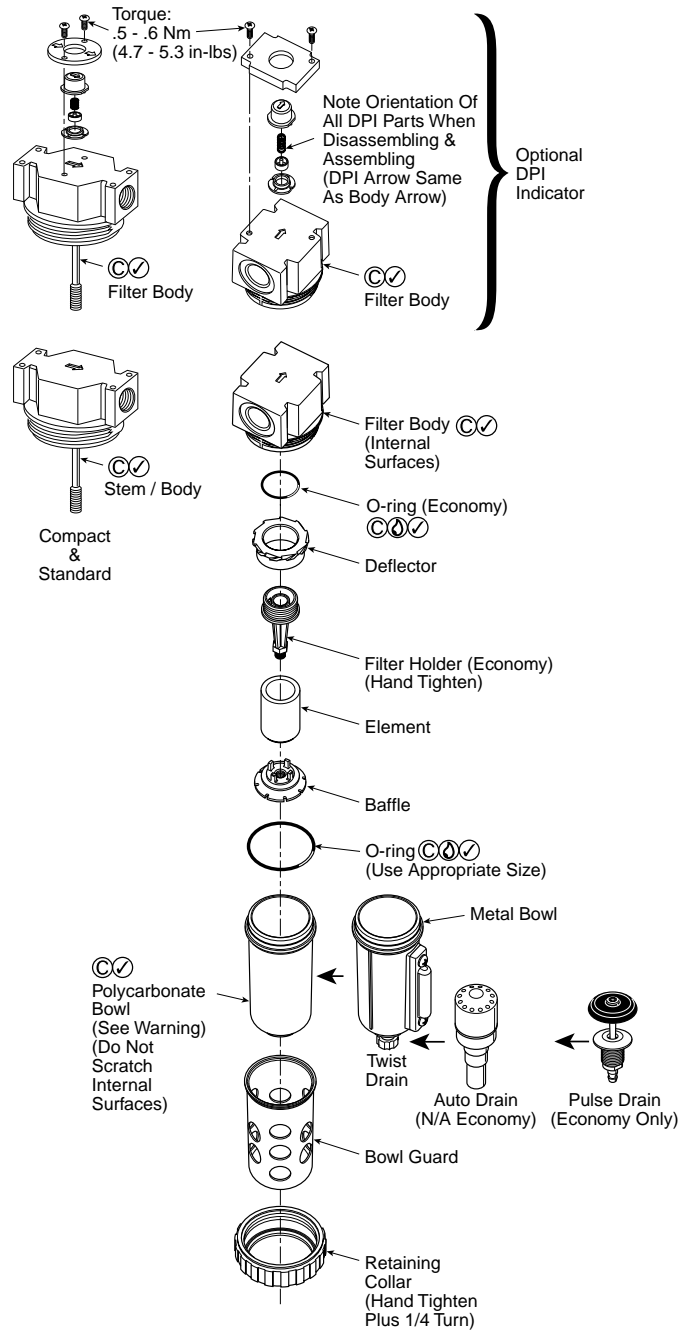

Installation

1. The filter should be installed with reasonable accessibility for service whenever possible – repair service kits are available. Keep pipe or tubing lengths to a minimum with inside clean and free of dirt and chips. Pipe joint compound should be used sparingly and applied only to the male pipe – never into the female port. Do not use PTFE tape to seal pipe joints – pieces have a tendency to break off and lodge inside the unit, possibly causing malfunction. Also, new pipe or hose should be installed between the filter and equipment being protected.
2. The upstream pipe work must be clear of accumulated dirt and liquids.
3. Select a filter location as close as possible to the equipment being protected and upstream of any pressure regulator.
4. Install filter so that air flows in the direction of arrow on body.
5. Install filter vertically with bowl drain mechanism at the bottom. Free moisture will thus drain into the sump “quiet zone” at the bottom of the bowl.

Operation and Service

1. Manual drain filters must be drained regularly before the separated moisture and oil reaches the bottom of the lower baffle.
2. The particulate filter element should be removed and replaced when pressure differential across the filter is 10 PSIG.
3. Adsorber elements are designed to adsorb vaporous contaminants. The relative efficiency of an adsorber varies depending on the vapor to be adsorbed and the environmental temperature. At higher temperatures, adsorbers become less efficient.

Adsorber elements are not particle filters. All particles and aerosols should be removed prior to adsorbing vaporous contaminants. The initial pressure drop across an adsorber element (1.5 PSIG maximum) should never increase. The presence of any liquids, aerosols or particulate matter in an adsorber indicates that the effective life of the element has been exceeded and the element should be replaced and the system cleaned.

The most effective method of testing whether an element needs to be replaced is to smell the air coming from the adsorber. Offensive odors will be present well before oil levels become detectable.

4. The differential pressure indicator, located on top of the filter body, gives a visual indication of the pressure differential across the filter element. Change the filter element when half or more of the orange piston is above the retaining ring when air is flowing. For units without a differential pressure indicator, pressure differential gauges should be used to determine when the maximum recommended pressure differential has been reached.
5. Shut off air supply and depressurize the unit, before servicing.
6. After servicing, apply system pressure and check for air leaks. If leakage occurs, **Do Not Operate** — conduct servicing again.

Kits Available

Description	Economy 1/4" & 3/8"	Compact 1/4", 3/8" & 1/2"	Standard 1/2" & 3/4"
Element Kits*			
5 Micron	PS902	PS702	PS802
40 Micron	PS901	PS701	PS801
Adsorber	PS931	PS731	PS831
Porous Bronze	PS988	PS788	PS888
DPI Repair Kit	PS781	PS781	PS781

*Element kits include body / bowl seal.

- ① Lightly grease with provided lubricant.
- ② Inspect for nicks, scratches, and surface imperfections. If present, reduced service life is probable and future replacement should be planned.
- ③ Clean with lint-free cloth.

 **WARNING**

To avoid unpredictable system behavior that can cause personal injury and property damage:

- Disconnect electrical supply (when necessary) before installation, servicing, or conversion.
- Disconnect air supply and depressurize all air lines connected to this product before installation, servicing, or conversion.
- Operate within the manufacturer's specified pressure, temperature, and other conditions listed in these instructions.
- Medium must be moisture-free if ambient temperature is below freezing.
- Service according to procedures listed in these instructions.
- Installation, service, and conversion of these products must be performed by knowledgeable personnel who understand how pneumatic products are to be applied.
- After installation, servicing, or conversion, air and electrical supplies (when necessary) should be connected and the product tested for proper function and leakage. If audible leakage is present, or the product does not operate properly, do not put into use.
- Warnings and specifications on the product should not be covered by paint, etc. If masking is not possible, contact your local representative for replacement labels.

Introduction

Follow these instructions when installing, operating, or servicing the product.

Application Limits

These products are intended for use in general purpose compressed air systems only.

Electrical Rating:

5 Amps - 12/24VDC, 125/250VAC

With Polycarbonate Bowl

	kPa	PSIG	bar
Operating Pressure Maximum	1000	150	10.3
Operating Temperature Maximum	52°C (125°F)		
Operating Temperature Minimum	0°C (32°F)		

With Metal Bowl

	kPa	PSIG	bar
Operating Pressure Maximum	1700	250	17.0
Operating Temperature Maximum	80°C (175°F)		
Operating Temperature Minimum	0°C (32°F)		

Operation and Service

1. The particulate and coalescing filter element should be removed and replaced when pressure differential across the filter is 10 PSID.
2. Adsorber elements are designed to adsorb vaporous contaminants. The relative efficiency of an adsorber varies depending on the vapor to be adsorbed and the environmental temperature. At higher temperatures, adsorbers become less efficient.

Adsorber elements are not particle filters. All particles and aerosols should be removed prior to adsorbing vaporous contaminants. The initial pressure drop across an adsorber element (1.5 PSIG maximum) should never increase. The presence of any liquids, aerosols or particulate matter in an adsorber indicates that the effective life of the element has been exceeded and the element should be replaced and the system cleaned.

The most effective method of testing whether an element needs to be replaced is to smell the air coming from the adsorber. Offensive odors will be present well before oil levels become detectable.

3. If the electronic differential pressure indicator, located on top of the filter body is wired as normally open, it sends an electrical signal when the differential is greater than the specified range. If the electronic differential pressure indicator is wired as normally closed, there will be a signal until the differential exceeds the specified range. Change the filter element when this happens. For units without a differential pressure indicator, pressure differential gauges should be used to determine when the maximum recommended pressure differential has been reached.
4. Shut off air supply and depressurize the unit, before servicing.
5. After servicing, apply system pressure and check for air leaks. If leakage occurs, **Do Not Operate** — conduct servicing again.

 **WARNING**

FAILURE OR IMPROPER SELECTION OR IMPROPER USE OF THE PRODUCTS AND/OR SYSTEMS DESCRIBED HEREIN OR RELATED ITEMS CAN CAUSE DEATH, PERSONAL INJURY AND PROPERTY DAMAGE.

This document and other information from The Company, its subsidiaries and authorized distributors provide product and/or system options for further investigation by users having technical expertise. It is important that you analyze all aspects of your application, including consequences of any failure and review the information concerning the product or systems in the current product catalog. Due to the variety of operating conditions and applications for these products or systems, the user, through its own analysis and testing, is solely responsible for making the final selection of the products and systems and assuring that all performance, safety and warning requirements of the application are met.

The products described herein, including without limitation, product features, specifications, designs, availability and pricing, are subject to change by The Company and its subsidiaries at any time without notice.

EXTRA COPIES OF THESE INSTRUCTIONS ARE AVAILABLE FOR INCLUSION IN EQUIPMENT / MAINTENANCE MANUALS THAT UTILIZE THESE PRODUCTS. CONTACT YOUR LOCAL REPRESENTATIVE.

.5 to .6 Nm
(.37 to .44 lb ft)
Torque

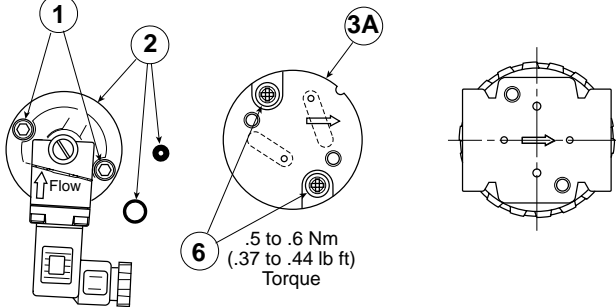

Orientation / Assembly for (05F) Electronic DPI

.5 to .6 Nm
(.37 to .44 lb ft)
Torque

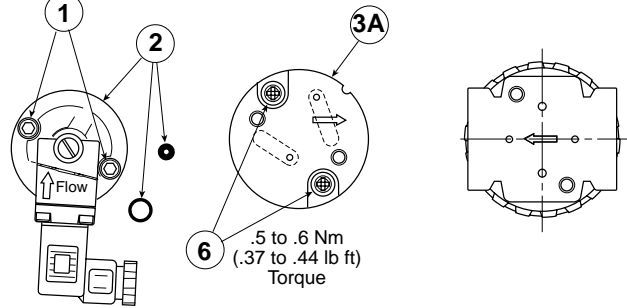

Orientation / Assembly for (15F) Electronic DPI

.5 to .6 Nm
(.37 to .44 lb ft)
Torque

.5 to .6 Nm
(.37 to .44 lb ft)
Torque

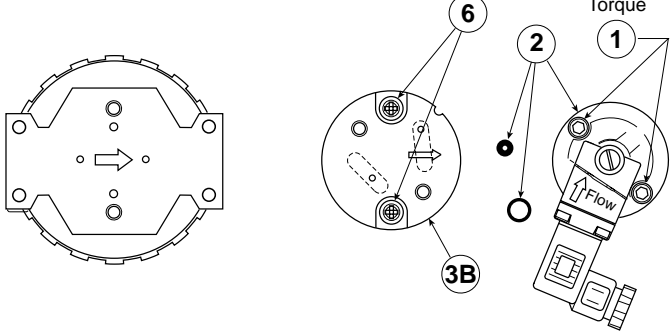

Orientation / Assembly for (06F / 07F / P3N) Electronic DPI

.5 to .6 Nm
(.37 to .44 lb ft)
Torque

.5 to .6 Nm
(.37 to .44 lb ft)
Torque

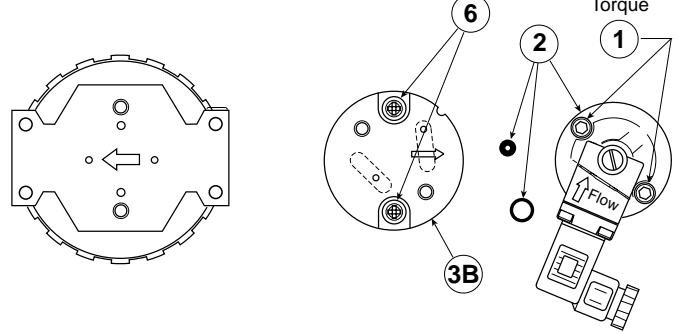

Orientation / Assembly for (11F / 12F / P3N Coalescing) Electronic DPI

Item 1: Screws (2) for mounting Electronic DPI
Item 2: Electronic DPI with two seals - Preset at 10 PSID

Item 3A: Adapter, 05F/15F
Item 3B: Adapter, 06F/07F/11F/12F/P3N
Item 6: Screw (2) for mounting adapter

Wiring Code

Pin 1: Common
Pin 2: Normally Closed
Pin 3: Normally Open

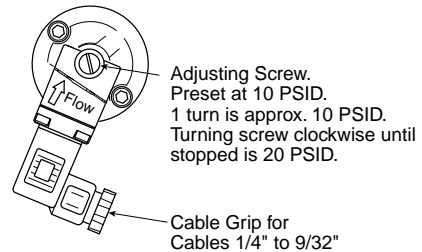
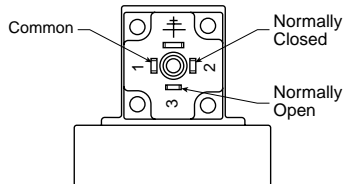

Kits Available

Description	05F/15F 1/4" & 3/8"	06F/11F 1/4", 3/8" & 1/2"	07F/12F 3/8", 1/2" & 3/4"	P3N 3/4", 1" & 1-1/2"
Element Kits*				
5 Micron	PS902	PS702	PS802	P3NKA00ESE
40 Micron	PS901	PS701	PS801	P3NKA00ESG
Coalescing Grade 6	PS924	PS724	PS824	P3NKA00ESC
Coalescing Grade 10	PS930	PS730	PS830	P3NKA00ES9
Adsorber	PS931	PS731	PS831	P3NKA00ESA
Porous Bronze	PS988	PS788	PS888	—
DPI Repair Kit	PS781	PS781	PS781	PS781
Electronic DPI Kit	PS764	PS764	PS764	PS764

*Element kits include body / bowl seal.

Pneumatic Division
 Richland, Michigan 49083
 269-629-5000

Installation & Service Instructions:
2F300E
1" Particulate, Adsorber & Coalescing Filter
ISSUED: October, 2006
Supersedes: March, 2005
 Doc.# 2F300, ECN# 061068, Rev. 9

⚠ WARNING

To avoid unpredictable system behavior that can cause personal injury and property damage:

- Disconnect electrical supply (when necessary) before installation, servicing, or conversion.
- Disconnect air supply and depressurize all air lines connected to this product before installation, servicing, or conversion.
- Operate within the manufacturer's specified pressure, temperature, and other conditions listed in these instructions.
- Medium must be moisture-free if ambient temperature is below freezing.
- Service according to procedures listed in these instructions.
- Installation, service, and conversion of these products must be performed by knowledgeable personnel who understand how pneumatic products are to be applied.
- After installation, servicing, or conversion, air and electrical supplies (when necessary) should be connected and the product tested for proper function and leakage. If audible leakage is present, or the product does not operate properly, do not put into use.
- Warnings and specifications on the product should not be covered by paint, etc. If masking is not possible, contact your local representative for replacement labels.

Safety Guide

For more complete information on recommended application guidelines, see the Safety Guide section of Pneumatic Division catalogs or you can download the **Pneumatic Division Safety Guide** at: www.parker.com/safety

Introduction

Follow these instructions when installing, operating, or servicing the product.

Application Limits

These products are intended for use in general purpose compressed air systems only.

Adsorber Filters are not effective on: Carbon monoxide, carbon dioxide, methane, ethane, ethylene or hydrogen. For a complete list of vapors that can and cannot be adsorbed effectively by activated charcoal adsorbers consult the factory.

Maximum Recommended Pressure Drop:

	kPa	PSIG	bar
Particulate Filter	70	10	0.7
Operating Pressure Maximum	1700	250	17.0
Operating Temperature Maximum	80°C (175°F)		
Operating Temperature Minimum	0°C (32°F)		

ANSI Symbols

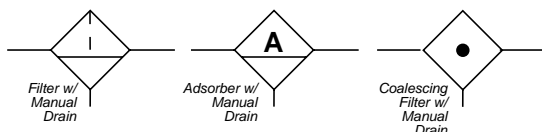

Installation

1. The filter should be installed with reasonable accessibility for service whenever possible – repair service kits are available. Keep pipe or tubing lengths to a minimum with inside clean and free of dirt and chips. Pipe joint compound should be used sparingly and applied only to the male pipe – never into the female port. Do not use PTFE tape to seal pipe joints – pieces have a tendency to break off and lodge inside the unit, possibly causing malfunction. Also, new pipe or hose should be installed between the filter and equipment being protected.
2. The upstream pipe work must be clear of accumulated dirt and liquids.
3. Select a filter location as close as possible to the equipment being protected and upstream of any pressure regulator.
4. Install filter so that air flows in the direction of arrow on body.
5. Install filter vertically with bowl drain mechanism at the bottom. Free moisture will thus drain into the sump “quiet zone” at the bottom of the bowl.

Operation and Service

1. Manual drain filters must be drained regularly before the separated moisture and oil reaches the bottom of the lower baffle.
2. The particulate filter element should be removed and replaced when pressure differential across the filter is 10 PSIG.
3. Adsorber elements are designed to adsorb vaporous contaminants. The relative efficiency of an adsorber varies depending on the vapor to be adsorbed and the environmental temperature. At higher temperatures, adsorbers become less efficient.

Adsorber elements are not particle filters. All particles and aerosols should be removed prior to adsorbing vaporous contaminants. The initial pressure drop across an adsorber element (1.5 PSIG maximum) should never increase. The presence of any liquids, aerosols or particulate matter in an adsorber indicates that the effective life of the element has been exceeded and the element should be replaced and the system cleaned.

⚠ WARNING

FAILURE OR IMPROPER SELECTION OR IMPROPER USE OF THE PRODUCTS AND/OR SYSTEMS DESCRIBED HEREIN OR RELATED ITEMS CAN CAUSE DEATH, PERSONAL INJURY AND PROPERTY DAMAGE.

This document and other information from The Company, its subsidiaries and authorized distributors provide product and/or system options for further investigation by users having technical expertise. It is important that you analyze all aspects of your application, including consequences of any failure and review the information concerning the product or systems in the current product catalog. Due to the variety of operating conditions and applications for these products or systems, the user, through its own analysis and testing, is solely responsible for making the final selection of the products and systems and assuring that all performance, safety and warning requirements of the application are met.

The products described herein, including without limitation, product features, specifications, designs, availability and pricing, are subject to change by The Company and its subsidiaries at any time without notice.

EXTRA COPIES OF THESE INSTRUCTIONS ARE AVAILABLE FOR INCLUSION IN EQUIPMENT / MAINTENANCE MANUALS THAT UTILIZE THESE PRODUCTS. CONTACT YOUR LOCAL REPRESENTATIVE.

The most effective method of testing whether an element needs to be replaced is to smell the air coming from the adsorber. Offensive odors will be present well before oil levels become detectable.

4. For Coalescing filter, a 5 micrometer pre-filter is recommended to protect the high efficiency filter and to prolong the elements life.
5. The differential pressure indicator, located on top of the filter body, gives a visual indication of the pressure differential across the filter element. Change the filter element when half or more of the orange piston is above the retaining ring when air is flowing. For units without a differential pressure indicator, pressure differential gauges should be used to determine when the maximum recommended pressure differential has been reached.
6. Shut off air supply and depressurize the unit, before servicing.
7. After servicing, apply system pressure and check for air leaks. If leakage occurs, Do Not Operate — conduct servicing again.

Service Kits Available

Description	Kit Number	Contains Items
Element Kits -		
5 Micron	P3NKA00ESE	(5) Bowl Seal and (2) Element
40 Micron	P3NKA00ESG	
Adsorber	P3NKA00ESA	
25 Micron Porous Bronze	P3NKA00ESJ	
Coalescing / Element Grade 6	P3NKA00ESC	
Coalescing / Element Grade 10	P3NKA00ES9	
DPI Repair Kit	PS781	(6) DPI components (not all shown)
Auto Drain Kit	PS506	(7) Auto Drain Assembly

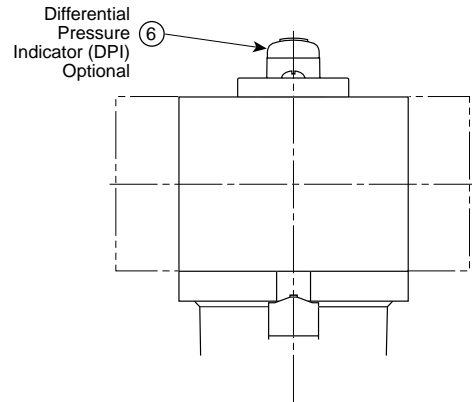
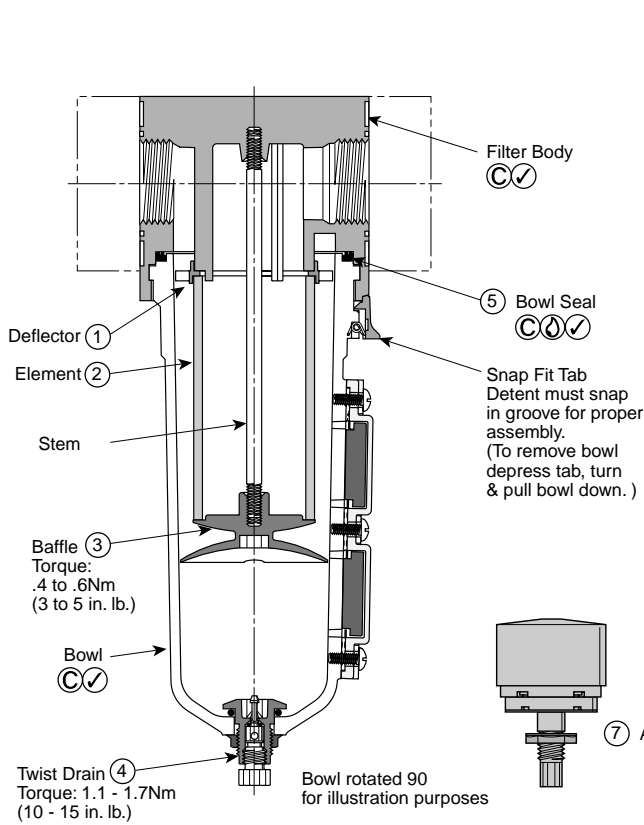

Coalescing Unit Shown

- ⌚ Lightly grease with provided lubricant.
- ✓ Inspect for nicks, scratches, and surface imperfections. If present, reduced service life is probable and future replacement should be planned.
- Ⓒ Clean with lint-free cloth.

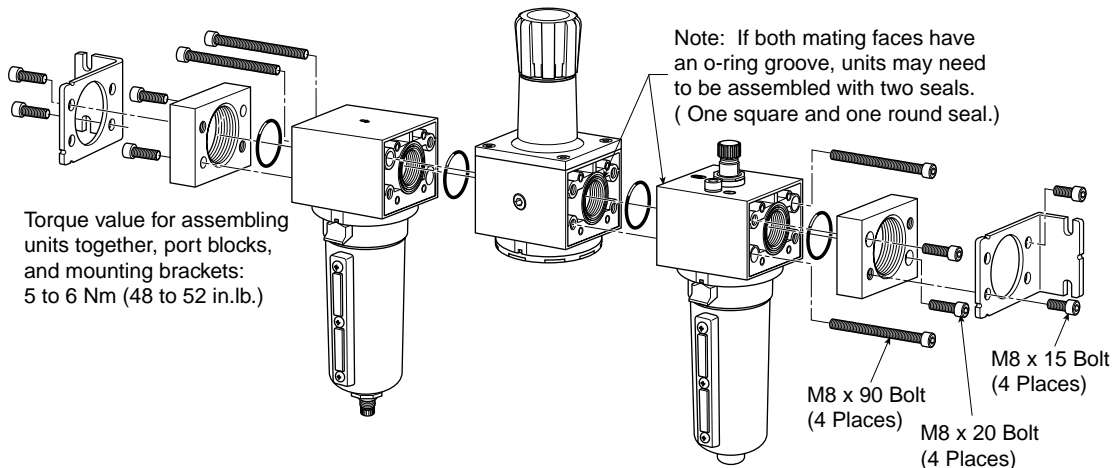

⚠ WARNING

To avoid unpredictable system behavior that can cause personal injury and property damage:

- Disconnect electrical supply (when necessary) before installation, servicing, or conversion.
- Disconnect air supply and depressurize all air lines connected to this product before installation, servicing, or conversion.
- Operate within the manufacturer's specified pressure, temperature, and other conditions listed in these instructions.
- Medium must be moisture-free if ambient temperature is below freezing.
- Service according to procedures listed in these instructions.
- Installation, service, and conversion of these products must be performed by knowledgeable personnel who understand how pneumatic products are to be applied.
- After installation, servicing, or conversion, air and electrical supplies (when necessary) should be connected and the product tested for proper function and leakage. If audible leakage is present, or the product does not operate properly, do not put into use.
- Warnings and specifications on the product should not be covered by paint, etc. If masking is not possible, contact your local representative for replacement labels.

⚠ CAUTION

Polycarbonate bowls and sight domes, being transparent and tough, are ideal for use with Filters and Lubricators. They are suitable for use in normal industrial environments, but should not be located in areas where they could be subjected to direct sunlight, an impact blow, nor temperatures outside of the rated range. As with most plastics, some chemicals can cause damage. Polycarbonate bowls and sight domes should not be exposed to chlorinated hydrocarbons, ketones, esters and certain alcohols. They should not be used in air systems where compressors are lubricated with fire-resistant fluids such as phosphate ester and diester types.

Metal bowls are recommended where ambient and/or media conditions are not compatible with polycarbonate bowls. Metal bowls resist the action of most such solvents, but should not be used where strong acids or bases are present or in salt laden atmospheres. Consult the factory for specific recommendations where these conditions exist.

TO CLEAN POLYCARBONATE BOWLS USE MILD SOAP AND WATER ONLY! DO NOT use cleansing agents such as acetone, benzene, carbon tetrachloride, gasoline, toluene, etc., which are damaging to this plastic.

Bowl guards are recommended for added protection of polycarbonate bowls where chemical attack may occasionally occur.

⚠ WARNING

To avoid polycarbonate bowl rupture that can cause personal injury or property damage, do not exceed bowl pressure or temperature ratings. Polycarbonate bowls have a 150 PSIG pressure rating and a maximum temperature rating of 125°F.

Safety Guide

For more complete information on recommended application guidelines, see the Safety Guide section of Pneumatic Division catalogs or you can download the **Pneumatic Division Safety Guide** at: www.parker.com/safety

Installation

1. Refer to WARNINGS and CAUTIONS.
2. Purge downstream air line of oil.
3. Install the unit with the air flowing in the direction indicated by the arrow on the body and / or the DP2 indicator.

4. The drain line connection is dependent on the type of drain that is selected.
5. Maximum inlet pressure and operating temperature ratings are: units with DP2 150 psig (10,3 bar) 150°F (66°C); units without DP2: 300 psig (20 bar) 150°F (66°C).

Maintenance

1. TO CLEAN OR REPLACE FILTER ELEMENT: Shut off air supply and reduce pressure in the unit to zero, remove the 8 screws from the filterhousing, unscrew the filter support and remove filter element.
 - a. IF THE UNIT HAS A RIGID FILTER ELEMENT: remove and clean periodically by tapping on a hard surface, and blowing off with air blow gun. Torque element support to 8 ±1 FT.-LB. when replacing element. Element should be cleaned/replaced when the DP2 pressure indicator is completely red or when the DP3 reads 7 psi (0,5 bar).
2. When the bowl becomes dirty, clean by wiping with dry, clean cloth.
3. Before placing the unit in service, make sure that the bowl is properly reinstalled, and securely bolted in place using the noted torque specifications.

Repair Kits And Replacement Parts

Filter Element kit (35F)	
(includes filter element, o-ring / gasket).....	FRP-95-505
Filter Element Kit (43F)	
(includes filter element, o-ring / gasket).....	FRP-95-508
Drain Plate Kits:	
Drain Plate 9/16 diameter (use with internal automatic mechanical float drain no. P32KA00DA).....	GRP-95-391
Drain Plate (1/2 NPT)	GRP-95-393
Drain Plate (1/2 BSPP).....	GRP-95-395
Bowl O-ring Kit (43F)	GRP-95-290
Bowl O-ring Kit (35F)	GRP-95-291
Differential Pressure Gauge	DP3-01-000
Differential Pressure Indicator (Standard)	DP2-01-001
Differential Pressure Removal Cap Kit	GRP-95-022
Internal Drains:	
Automatic Mechanical Drain	
(Fluorocarbon Seals).....	P32KA00DA

⚠ WARNING

FAILURE OR IMPROPER SELECTION OR IMPROPER USE OF THE PRODUCTS AND/OR SYSTEMS DESCRIBED HEREIN OR RELATED ITEMS CAN CAUSE DEATH, PERSONAL INJURY AND PROPERTY DAMAGE.

This document and other information from The Company, its subsidiaries and authorized distributors provide product and/or system options for further investigation by users having technical expertise. It is important that you analyze all aspects of your application, including consequences of any failure and review the information concerning the product or systems in the current product catalog. Due to the variety of operating conditions and applications for these products or systems, the user, through its own analysis and testing, is solely responsible for making the final selection of the products and systems and assuring that all performance, safety and warning requirements of the application are met.

The products described herein, including without limitation, product features, specifications, designs, availability and pricing, are subject to change by The Company and its subsidiaries at any time without notice.

EXTRA COPIES OF THESE INSTRUCTIONS ARE AVAILABLE FOR INCLUSION IN EQUIPMENT / MAINTENANCE MANUALS THAT UTILIZE THESE PRODUCTS. CONTACT YOUR LOCAL REPRESENTATIVE.

Automatic Electric Drain Valves

Model Number Kit	Port Size NPT	Voltage	Operating Pressure
WDV3-G14BL	1/2"	115 VAC	232 PSIG
WDV3-G24BL	1/2"	230 VAC	232 PSIG
WDV3-G34BL	1/2"	24 VDC	232 PSIG

Zero Air Loss Condensation Drain

Model Number Kit	Port Size NPT	Voltage	Operating Pressure
ED3002N115-KL	1 x 3/8, 3/8	115 VAC	232 PSIG
ED3004N115-KL	1 x 1/2, 3/8	115 VAC	232 PSIG
ED3007N115-KL	2 x 1/2, 3/8	115 VAC	232 PSIG
ED3030N115-KL	2 x 1/2, 3/8	115 VAC	232 PSIG
ED3100N115-KL	2 x 1/2, 3/8	115 VAC	232 PSIG

DP3 Differential Pressure Gauge Installation Instructions on 3x / 4x Series Filters

1. Remove and discard the plastic cap, screws and O-rings from top of unit.
2. To install the new DP3 Differential Pressure Gauge, pry the cap out of the housing and separate the mounting block from the DP3 by removing the 2 screws under the cap. Make sure that air flow direction arrows on DP3 match flow arrows (same direction) on filter unit. Make sure O-Rings are properly seated on bottom of DP3, and attach DP3 to filter, using the special 60mm mounting screws (2 required) with flat ground on threads.

CAUTION! Overtightening the screws may damage the Differential Pressure Gauge.

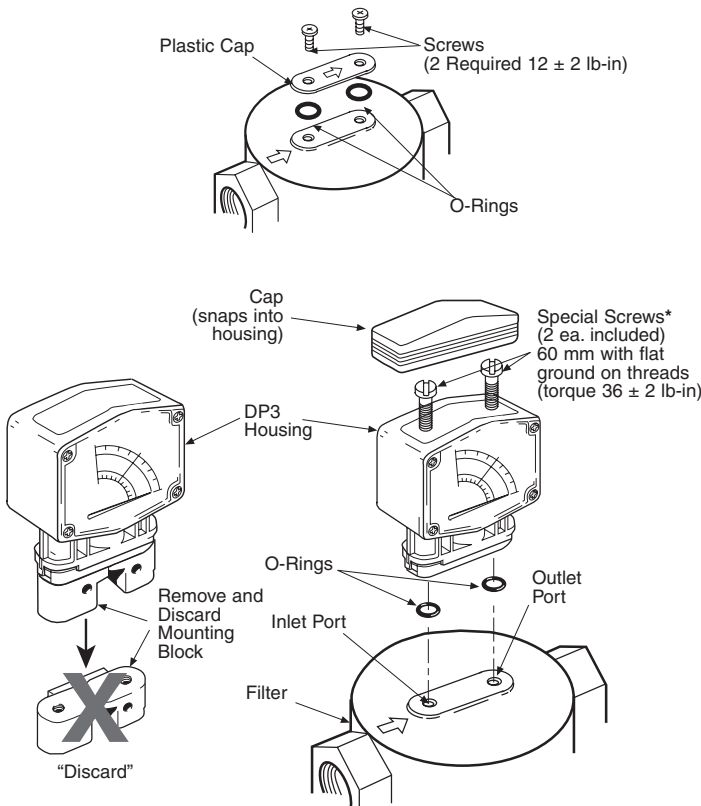

* **CAUTION:** Use special 60 mm (long) screw to mount gauge to filter only.

3. Replace coalescing element when differential pressure reaches the red band.

35F / 43F

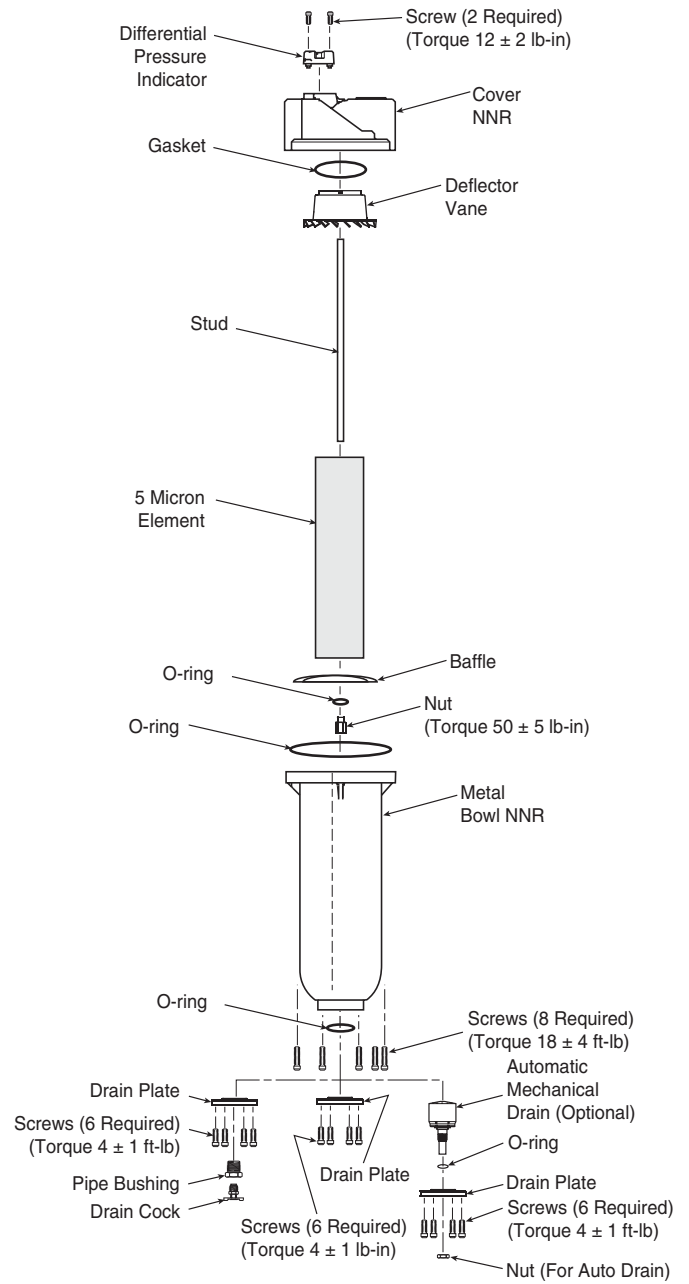

Automatic Mechanical Float Drain

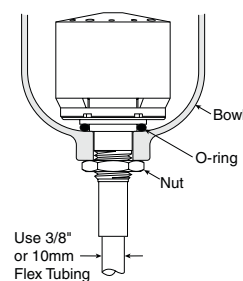

⚠ WARNING

To avoid unpredictable system behavior that can cause personal injury and property damage:

- Disconnect electrical supply (when necessary) before installation, servicing, or conversion.
- Disconnect air supply and depressurize all air lines connected to this product before installation, servicing, or conversion.
- Operate within the manufacturer's specified pressure, temperature, and other conditions listed in these instructions.
- Medium must be moisture-free if ambient temperature is below freezing.
- Service according to procedures listed in these instructions.
- Installation, service, and conversion of these products must be performed by knowledgeable personnel who understand how pneumatic products are to be applied.
- After installation, servicing, or conversion, air and electrical supplies (when necessary) should be connected and the product tested for proper function and leakage. If audible leakage is present, or the product does not operate properly, do not put into use.
- Warnings and specifications on the product should not be covered by paint, etc. If masking is not possible, contact your local representative for replacement labels.

Introduction

Follow these instructions when installing, operating, or servicing the product.

Application Limits

These products are intended for use in general purpose compressed air systems only.

Maximum Recommended Pressure Drop:

	kPa	PSIG	bar
Particulate Filter	70	10	0.7
	kPa	PSIG	bar
Operating Pressure Maximum with Manual Drain	2068	300	20.7
Operating Pressure Maximum with Automatic Drain*	1207	175	12.0

* When using an Automatic Drain, minimum inlet pressure is 69kPa (15 PSIG & 0 bar)

Operating Temperature Range:

Manual Drain	0°C to 82°C (32°F to 180°F)
Automatic Drain	0°C to 49°C (32°F to 120°F)

Symbols

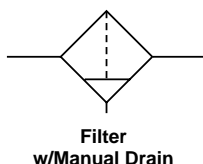

Installation

1. Filter unit should be installed with reasonable accessibility for service whenever possible - repair service kits are available. Keep pipe or tubing lengths to a minimum with inside clean and free of dirt and chips. Pipe joint compound should be used sparingly and applied only to the male pipe - never into the female port. Do not use PTFE tape to seal pipe joints - pieces could break off from the outlet port and lodge inside units which are located downstream, possibly causing malfunction.
2. Blow all upstream pipe work clear of accumulated dirt and liquids.
3. Select a filter location as close as possible to the equipment being protected and upstream of any pressure regulator.
4. Install filter so that air flow is in the direction of the arrow.
5. Install filter vertically with the bowl drain mechanism at the bottom. Free moisture will thus drain into the sump "quiet zone" at the bottom of the bowl (automatic drain models are recommended as standard equipment).

Operation

Both free moisture and solids are removed automatically by the filter. There are no moving parts.

The filter element should be changed when pressure differential across the filter is 69 kPa (10 PSIG). Pressure differential gauges should be used to determine when the maximum recommended pressure differential has been reached. (See **Service Procedure** section.)

⚠ Caution: DO NOT EXCEED THE RATED RECOMMENDED FLOWS. The minimum flow is ten percent of the normal rating.

Manual drain filters must be drained regularly before the separated moisture and oil reaches the bottom of the filter element. Automatic drain models will collect and dump the liquid automatically.

⚠ WARNING

FAILURE OR IMPROPER SELECTION OR IMPROPER USE OF THE PRODUCTS AND/OR SYSTEMS DESCRIBED HEREIN OR RELATED ITEMS CAN CAUSE DEATH, PERSONAL INJURY AND PROPERTY DAMAGE.

This document and other information from The Company, its subsidiaries and authorized distributors provide product and/or system options for further investigation by users having technical expertise. It is important that you analyze all aspects of your application, including consequences of any failure and review the information concerning the product or systems in the current product catalog. Due to the variety of operating conditions and applications for these products or systems, the user, through its own analysis and testing, is solely responsible for making the final selection of the products and systems and assuring that all performance, safety and warning requirements of the application are met.

The products described herein, including without limitation, product features, specifications, designs, availability and pricing, are subject to change by The Company and its subsidiaries at any time without notice.

EXTRA COPIES OF THESE INSTRUCTIONS ARE AVAILABLE FOR INCLUSION IN EQUIPMENT / MAINTENANCE MANUALS THAT UTILIZE THESE PRODUCTS. CONTACT YOUR LOCAL REPRESENTATIVE.

Service Procedure - (Refer to Figure 1)

⚠ Caution: Shut off air supply and exhaust the pressure trapped within the filter bowl before servicing unit.

1. Unscrew threaded collar and remove the bowl from the body.
2. To install a new filter element, use the following procedure:
 - a. Unscrew the lower baffle and remove filter element.
 - b. This element can not be cleaned and should be replaced when a pressure differential across the filter unit becomes excessive.
 - c. Clean all internal parts and bowl before reassembling.
 - d. Install element.
 - e. Attach lower baffle and tighten.
 - f. Lubricate bowl seal to assist with retaining it in position.

⚠ Caution: Use only mineral based oils or grease. Do not use synthetic oils such as esters and do not use silicones.

- g. Place new bowl seal into the groove in the body.
3. Place bowl into collar and position bowl against the body and tighten collar.

If you have questions concerning how to service this unit, contact your local authorized dealer or your customer service representative.

Service Kits Available

Description	Kit Number
Element (40 Micron)	EK602B/N
Element (5 Micron)	EK602VB/N
Bowl	PBK603B
Deflector	PRK602C
Auto Drain	PRK602MD

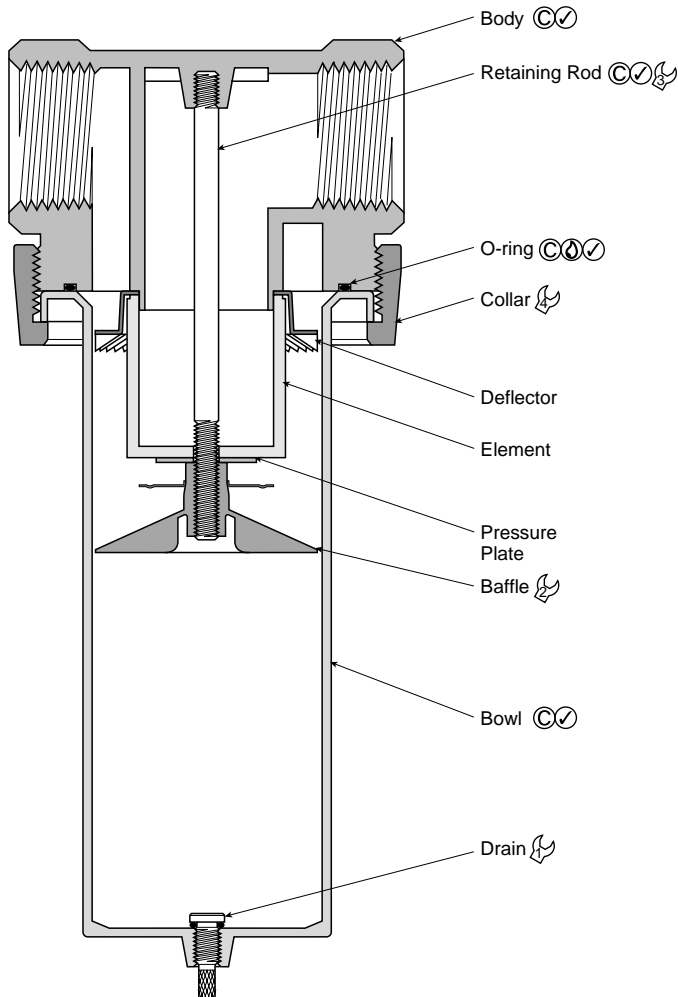

**PF602 Filter Unit with Twist Drain
Figure 1**

- Lightly grease with provided lubricant.
 - Inspect for nicks, scratches, and surface imperfections. If present, reduced service life is probable and future replacement should be planned.
 - Clean with lint-free cloth.
- Torque: Nm (In.-Lb.)**
- Hand Tight
 - 1,5 to 1,9 Nm (13 to 17 in. lb.)
 - 1,7 to 2,8 Nm (15 to 25 in. lb.)
 - 5,6 to 8,5 Nm (50 to 75 in. lb.)

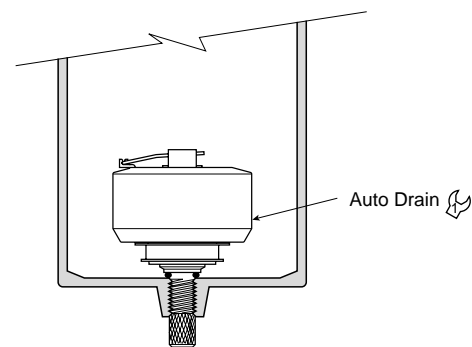

**PF602 Filter Unit with Automatic Drain
Figure 2**

ENGLISH

⚠ WARNING

To avoid unpredictable system behavior that can cause personal injury and property damage:

- Disconnect electrical supply (when necessary) before installation, servicing, or conversion.
- Disconnect air supply and depressurize all air lines connected to this product before installation, servicing, or conversion.
- Operate within the manufacturer's specified pressure, temperature, and other conditions listed in these instructions.
- Medium must be moisture-free if ambient temperature is below freezing.
- Service according to procedures listed in these instructions.
- Installation, service, and conversion of these products must be performed by knowledgeable personnel who understand how pneumatic products are to be applied.
- After installation, servicing, or conversion, air and electrical supplies (when necessary) should be connected and the product tested for proper function and leakage. If audible leakage is present, or the product does not operate properly, do not put into use.
- Warnings and specifications on the product should not be covered by paint, etc. If masking is not possible, contact your local representative for replacement labels.

⚠ WARNING

FAILURE OR IMPROPER SELECTION OR IMPROPER USE OF THE PRODUCTS AND/OR SYSTEMS DESCRIBED HEREIN OR RELATED ITEMS CAN CAUSE DEATH, PERSONAL INJURY AND PROPERTY DAMAGE.

This document and other information from The Company, its subsidiaries and authorized distributors provide product and/or system options for further investigation by users having technical expertise. It is important that you analyze all aspects of your application, including consequences of any failure and review the information concerning the product or systems in the current product catalog. Due to the variety of operating conditions and applications for these products or systems, the user, through its own analysis and testing, is solely responsible for making the final selection of the products and systems and assuring that all performance, safety and warning requirements of the application are met.

The products described herein, including without limitation, product features, specifications, designs, availability and pricing, are subject to change by The Company and its subsidiaries at any time without notice.

EXTRA COPIES OF THESE INSTRUCTIONS ARE AVAILABLE FOR INCLUSION IN EQUIPMENT / MAINTENANCE MANUALS THAT UTILIZE THESE PRODUCTS. CONTACT YOUR LOCAL REPRESENTATIVE.

Installation

1. Refer to WARNINGS.
2. Install as close as possible to point where air is being used.
3. Install so that air flows into the body and out to the adapter.
4. Maximum pressure rating is 200 PSIG (14 bar). Temperature range is 32°F to 150°F (0°C to 65.5°C).

Maintenance

1. Service unit at least every 6 months.
2. Replace filter element periodically, or when pressure drop exceeds 10 PSIG.

Repair Kits and Replacement Parts

Filter KitPS436

FRENCH

FICHE D'INSTALLATION ET D'ENTRETIEN
 Filtre modèle 02F

⚠ AVERTISSEMENT

Afin d'éviter un fonctionnement imprévu du système pouvant occasionner des blessures aux personnes et des dommages matériels :

- Débrancher l'alimentation électrique (si nécessaire) avant toute installation, entretien ou conversion.
- Débrancher l'alimentation en air et dépressuriser toutes les canalisations d'air connectées à cet appareil avant installation, entretien ou conversion.
- Utiliser l'appareil conformément aux normes de pression, température, et autres conditions spécifiées par le fabricant dans ces instructions.
- Le médium doit être exempt d'humidité si la température descend en dessous de 0°C.
- L'entretien doit se faire conformément aux procédures décrites ici.
- L'installation, l'entretien, et la conversion de ces appareils doivent être effectués par des personnels qualifiés, au fait des techniques pneumatiques.
- Après installation, entretien, ou conversion, les alimentations en air et en électricité (si nécessaire) seront connectées et l'appareil testé pour vérifier son fonctionnement correct et l'absence de fuites. Si l'appareil présente une fuite audible ou ne fonctionne pas correctement, ne pas l'utiliser.
- Les inscriptions concernant les avertissements et spécifications sur l'appareil ne devront pas être recouvertes de peinture, etc. Si le masquage est impossible, contactez votre représentant local pour des étiquettes de remplacement.

⚠ AVERTISSEMENT

LA DEFAILLANCE, LE CHOIX ERRONE OU L'USAGE NON CONFORME DES PRODUITS ET/OU SYSTEMES ICI DECRITS, OU PRODUITS Y AFFECTANT, PEUVENT ENTRAÎNER LA MORT, DES BLESSURES AUX PERSONNES ET DES DOMMAGES MATERIELS.

Ce document et autres informations de « The Company », ses filiales et distributeurs autorisés offre des options complémentaires d'utilisation du produit et/ou système pour des utilisateurs ayant l'expertise technique requise. Il est important que vous analysiez tous les aspects de l'usage prévu, y compris les conséquences de toute défaillance, et que vous passiez en revue les informations concernant les produits et systèmes dans le catalogue actuel des produits.

En raison de la diversité des conditions de fonctionnement et d'utilisation de ces produits ou systèmes, l'utilisateur, et lui seul, selon ses propres analyses et tests, porte la responsabilité du choix final des produits et systèmes. Il est aussi de sa responsabilité pleine et entière de s'assurer que les produits soient utilisés conformément aux normes de sécurité et avertissements d'usage.

Les produits décrits ici, y compris, mais non exclusivement, les caractéristiques des produits, spécifications, aspects, disponibilité et prix, sont susceptibles de modification à tout moment et sans préavis par « The Company » et ses filiales.

DES EXEMPLAIRES SUPPLEMENTAIRES DE CES INSTRUCTIONS SONT DISPONIBLES POUR ACCOMPAGNER LES APPAREILS/MANUELS D'ENTRETIEN CORRESPONDANT A CES PRODUITS. CONTACTEZ VOTRE REPRESENTANT LOCAL.

Installation

1. Lire L'AVERTISSEMENTS ci-haut avant l'installation.
2. Installer le dispositif aussi près que possible du point d'utilisation de l'air.
3. Installer le dispositif de manière à ce que l'air entre par le corps et sorte par l'adaptateur.
4. La pression maximale d'utilisation est de 14 bars (200 PSIG). La température d'utilisation se situe entre 0°C et 65,5°C (de 32°F à 150°F).

Entretien

1. Effectuer l'entretien du dispositif au moins tous les six mois.
2. Remplacer l'élément filtrant périodiquement ou lorsque la pression baisse de plus de 10 PSIG.

Trousses de Réparation et Pièces de Rechange

Trousse de filtrePS436

HOJA DE INSTALACION Y MANTENIMIENTO
Filtro Modelo 02F

- Filter Model 02F
- Filtre modèle 02F
- Filtro Modelo 02F

⚠ ADVERTENCIA

Para evitar un comportamiento impredecible del sistema que pueda ocasionar lesiones personales y daños a la propiedad:

- Antes de instalar, reparar o convertir, desconecte el suministro eléctrico (cuando sea necesario).
- Antes de instalar, reparar o convertir, desconecte el suministro de aire y despresurice todas las líneas de aire que están conectadas a este producto.
- Haga funcionar dentro de la presión, temperatura y demás condiciones especificadas por el fabricante y que se incluyen en estas instrucciones.
- El medio debe estar libre de humedad si la temperatura ambiente se encuentra por debajo del punto de congelación.
- Repare de acuerdo con los procedimientos que se incluyen en estas instrucciones.
- La instalación, reparación y conversión de estos productos debe ser realizada por personal competente que entienda la manera en que se deben aplicar los productos neumáticos.
- Después de la instalación, reparación y conversión, se debe conectar los suministros eléctricos y de aire (cuando sea necesario), y el producto se debe poner a prueba para determinar que funciona correctamente y no tiene pérdidas. Si se detecta una pérdida audible, o si el producto no funciona correctamente, no lo ponga en funcionamiento.
- Las advertencias y especificaciones que aparecen en el producto no deben estar cubiertas por pintura, etc. Si no resulta posible colocarlo con cinta adhesiva, póngase en contacto con su representante local para obtener etiquetas de repuesto.

⚠ ADVERTENCIA

EL FALLO O LA SELECCIÓN INCORRECTA O EL USO INCORRECTO DE LOS PRODUCTOS Y/O SISTEMAS AQUÍ DESCRITOS U OTROS ARTICULOS RELACIONADOS PUEDE RESULTAR EN MUERTE, LESIONES PERSONALES Y DAÑO A LA PROPIEDAD.

Este documento y demás información de la compañía, sus subsidiarias y distribuidores autorizados ofrecen opciones de productos y sistemas para mayor investigación por parte de los usuarios que cuentan con conocimientos técnicos. Es importante que analice todos los aspectos de su aplicación, incluyendo las consecuencias de cualquier fallo y que revise la información concerniente al producto o los sistemas que se encuentran en el catálogo actual de productos. Debido a la variedad de condiciones de funcionamiento y aplicaciones para estos productos o sistemas, el usuario, mediante su propio análisis y pruebas, es únicamente responsable por la selección final de los productos y sistemas, y por garantizar que se cumpla con todos los requisitos de funcionamiento, seguridad y advertencia de la aplicación.

Los productos aquí descritos, incluyendo pero sin limitarse, a las características del producto, las especificaciones, los diseños, la disponibilidad y los precios, están sujetos a cambios por parte de la compañía y de sus subsidiarias en cualquier momento sin aviso.

SE PUEDE OBTENER COPIAS ADICIONALES DE ESTAS INSTRUCCIONES PARA INCLUIR CON EL EQUIPO / LOS MANUALES DE MANTENIMIENTO QUE UTILIZAN ESTOS PRODUCTOS. COMUNIQUESE CON SU REPRESENTANTE LOCAL.

Instalacion

1. Remítase a la ADVERTENCIAS.
2. Efectúe la instalación lo más cerca posible del punto donde se está utilizando el aire.
3. Efectúe la instalación de modo que el aire circule dentro del cuerpo y fuera del adaptador.
4. La clasificación de presión máxima es de 14 bar (200 PSIG). El rango de temperatura es de 0°C a 65,5°C (32°F a 150°F).

Mantenimiento

1. De servicio a la unidad por lo menos cada seis meses.
2. Reemplace el elemento del filtro periódicamente, o cuando la caída de presión exceda 10 PSIG.

Juegos de Reparacion y Repuestos

Juego de filtros PS436

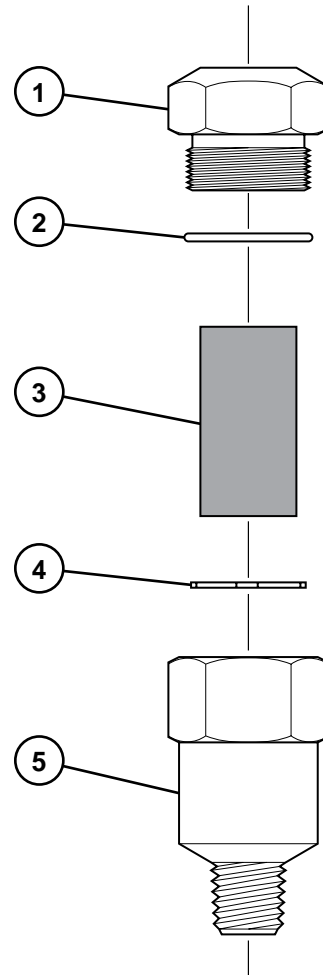

- 1 ADAPTER
ADAPTATEUR
ADAPTADOR
- 2 O-RING
JOINT TORIQUE
JUNTA TORICA
- 3 FILTER ELEMENT
ÉLÉMENT FILTRANT
ELEMENTO DEL FILTRO
- 4 BAFFLE
CHICANE
DESVIADOR
- 5 BODY
CORPS
CUERPO

UK Common Ported Regulators
CN 汇流型减压阀
FR Régulateurs à orifices communs

DE Regler mit allgemeinen Anschlüssen
IT Regolatori con porte comuni
JP マニホールドレギュレータ

KR 공통급기 레귤레이터
ES Reguladores de boca común
SE Sammanbyggda regulatorer

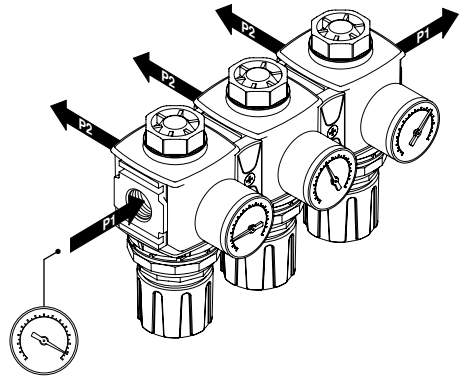

UK Safety Lockout Valves
CN 可锁定安全阀
FR Distributeurs verrouillables

DE Sicherheitsabschaltventile
IT Valvole di bloccaggio di sicurezza
JP ロックアウトバルブ

KR 안전 잠알 배기밸브
ES Válvulas de bloqueo - seguridad
SE Säkerhetsavstängningsventiler

UK Ball Valve
CN 球阀
FR Vanne à boisseau
DE Kugelventil
IT Valvola a sfera
JP ボールバルブ式
KR 볼밸브
ES Válvula de bola
SE Kulventil

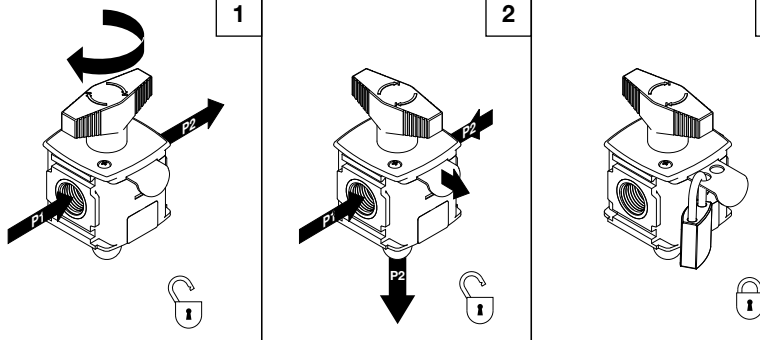

UK Slide Valve
CN 截止阀
FR Tiroir
DE Schieberventil
IT Valvola scorrevole
JP スライドバルブ式
KR 슬라이드밸브
ES Válvula de corredera
SE Slidventil

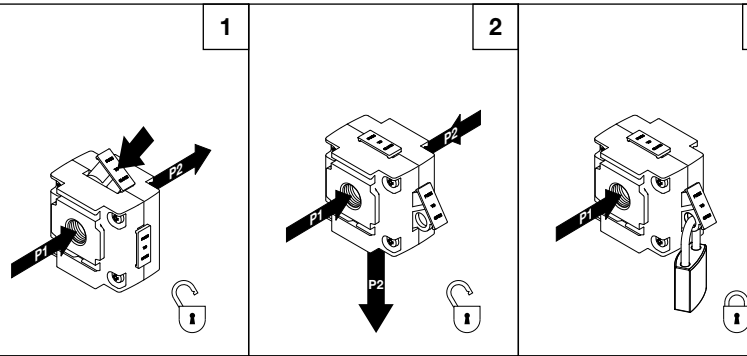

5FR100 Rev. E

Global Air Preparation System

EN130810

EN WARNING

To avoid unpredictable system behaviour that can cause personal injury and proper damage:

- Disconnect electrical supply (when necessary) before, installation, servicing, or conversion.
- Disconnect air supply and depressurize all air lines connected to this product before installation, servicing or conversion.
- Operate within the manufacturer's specified pressure, temperature, and other conditions listed in these instructions.
- Medium must be moisture-free if ambient temperature is below freezing.
- Service according to procedures listed in these instructions.
- Installation, service and conversion of these products must be performed by knowledgeable personnel who understand how pneumatic products are to be applied.
- After installation, servicing or conversion, air and electrical supplies (when necessary) should be connected and the product tested for proper function and leakage. If audible leakage is present or the product does not operate properly, do not put into use.
- Warning and specifications on the product should not be covered by paint, etc. If masking is not possible, contact your local representative for replacement labels.

EN WARNING

FAILURE OR IMPROPER SELECTION OR IMPROPER USE OF THE PRODUCTS AND/OR SYSTEMS DESCRIBED HEREIN OR RELATED ITEMS CAN CAUSE DEATH, PERSONAL INJURY AND PROPERTY DAMAGE.

This document and other information from the Company, its subsidiaries and authorised distributors provide product and/or system options for further investigation by users having technical expertise. It is important that you analyze all aspects of your application, including consequences of any failure and review the information concerning the product or systems in the current product catalogue. Due to the variety of operating conditions and applications for these products or systems, the user, through its own analysis and testing, is solely responsible for making the final selection of the products and systems and assuring that all performance, safety and warning requirements of the application are met.

The products described herein, including without limitation, product features, specifications, designs, availability and pricing, are subject to change by The Company and its subsidiaries at any time without notice.

EN CAUTION

Polycarbonate bowls, being transparent and tough, are ideal for use with Filters and Lubricators. They are suitable for use in normal industrial environments, but should not be located in areas where they could be subjected to direct sunlight, an impact blow, nor temperatures outside of the rated range. As with most plastics, some chemicals can cause damage. Polycarbonate bowls should not be used where exposed chlorinated hydrocarbons, ketones, esters, and certain alcohols. They should not be used in air systems where compressors are lubricated with fire-resistant fluids such as phosphate ester and diester types.

Metal bowls are recommended where ambient and/or media conditions are not compatible with polycarbonate bowls. Metal bowls resist the action of most such solvents, but should not be used where strong acids or bases are present or in salt laden atmospheres. Consult the factory for specific recommendations where these conditions exist.

TO CLEAN POLYCARBONATE BOWLS USE MILD SOAP AND WATER ONLY! DO NOT use cleansing agents such as acetone, benzene, carbon tetrachloride, gasoline, toluene, etc., which are damaging to this plastic.

EN Safety Guide

For more complete information on recommended application guidelines, see the Safety Guide section of Pneumatic Division catalogues or you can download the Pneumatic Division Safety Guide at: www.parker.com/safety

EN WARNING

To avoid polycarbonate bowl rupture that can cause personal injury or property damage, do not exceed bowl pressure or temperature ratings. Polycarbonate bowls have a 150 PSIG (10 bar) pressure rating and a maximum temperature rating of 125°F (52°C).

EXTRA COPIES OF THESE INSTRUCTIONS ARE AVAILABLE FOR INCLUSION IN EQUIPMENT / MAINTENANCE MANUALS THAT UTILIZE THESE PRODUCTS. CONTACT YOUR LOCAL REPRESENTATIVE.

CN 警告

为避免不可预测的系统运作而导致人身伤害和财产损失:

- 安装, 维修和改动前必须断开电源供应;
- 安装, 维修和改动前必须断开电源供应, 释放连接该产品的管路压力;
- 必须在厂商所指定的压力, 温度和其他使用说明书中注明的环境条件下操作使用;
- 在环境温度低于零下时介质必须是无油的;
- 根据使用说明书中厂商推荐的程序保养;
- 必须由气动专业人士来安装, 维护和改动产品;
- 安装, 维修, 改动后, 气源和电气需要连接, 并测试产品功能及是否有泄露。如果有可听到的泄漏声或操作不确, 不可投入使用;
- 产品上的警示和规范不能被油漆等覆盖。如果标签不清晰, 请联系相关负责人更换标签。

CN 警告

错误或者不正确地选择和用 错误或者不正确地选择和产品信息有可能会致死亡, 人身伤害和财产损失。

这个文件和另外的信息来自公司总部, 它是给分销商补充和授权产品或者系统的选项, 是给用户调查研究用的技术资料。分析你的所有应用, 包括任何一旦 发生错误的后果并在现有的产品目录中阅读相关产品或系统信息。对于您来说 都是非常必要的。由于操作环境和产品或系统的使用是多样性的, 用户通过 自己的分析和测试, 对最终产品和系统选择负有绝对责任, 并确保确保所有产 品的性能, 安全和应用时需要注意的问题都已满足。

这里提到的产品, 包括无限制性, 产品特性, 说明书, 设计, 实用性和 价格可由公司总部及其下属公司在没有通知的情况下改变。

CN 注意

碳酸聚酯水杯是透明坚固的, 是过滤器和油雾器的理想选择。适合一般工业环境应用, 但是不适用于那些阳光直射, 冲击和户外温差大的场合。因为含有大量塑料, 某些化学物质会损坏水杯。碳酸聚酯水杯不能暴露于碳化氢化合物, 酮, 酯和某些酒精。此类水杯不能应用于被防火型液体, 如, 碳酸盐酯和二酯类润滑过的空压机的气动系统中。

在那些不适合碳酸聚酯水杯的环境中, 推荐使用金属水杯。金属水杯能抵抗大多数溶剂, 但是不能在强酸, 含盐的场所。对于特殊场合请咨询工厂。

碳, 汽油, 甲苯等清洁剂, 这会直接损害塑料。

CN 安全指南

更多完整的推荐应用指导信息, 请见气动样本中的安全指南部分或者可以在 气动部门安全指南网站上下载资料: www.parker.com/safety

CN 警告

为了避免碳酸聚酯水杯破裂而导致的人身和财产损失, 不能使用超过水杯的压力和温度范围。碳酸聚酯水杯最高承受 150 PSIG (10bar)压力和最高125°F (52°C)的温度

如需多份涉及这些产品维修/操作指南的使用说明书。请联系当地办事处。

FR MISE EN GARDE

Afin de prévenir tout comportement imprévisible du système pouvant entraîner des accidents et des dommages matériels :

- Débrancher l'alimentation électrique (s'il y a lieu) avant de procéder à l'installation, à l'entretien ou à la transformation.
- Débrancher l'approvisionnement en air et mettre hors pression toutes les conduites d'air de ce produit avant de procéder à l'installation, à l'entretien ou à la transformation.
- Faire fonctionner dans les conditions de pression, de température et autres qui sont indiquées dans ces instructions.
- Si la température ambiante est inférieure au point de congélation, le fluide doit être exempt d'humidité.
- Effectuer l'entretien conformément aux procédures qui sont indiquées dans ces instructions.
- L'installation, l'entretien et la transformation de ces produits doivent être effectués par des personnes familiarisées avec les produits pneumatiques.
- Après l'installation, l'entretien ou la transformation, rétablir l'alimentation électrique ainsi que l'approvisionnement en air (s'il y a lieu) et tester le produit afin de s'assurer qu'il fonctionne bien et qu'il n'y a pas de fuites. Si une fuite s'entend ou si le produit ne fonctionne pas correctement, ne pas le mettre en service.
- Les mises en garde et les indications portées sur le produit ne doivent pas être recouvertes par de la peinture, etc. Si le masquage n'est pas possible, contacter le représentant local pour obtenir des étiquettes de remplacement.
- Les mises en garde et les indications portées sur le produit ne doivent pas être recouvertes par de la peinture, etc. Si le masquage n'est pas possible, contacter le représentant local pour obtenir des étiquettes de remplacement.

FR MISE EN GARDE

LA NON OBSERVATION D'INSTRUCTIONS OU LA SÉLECTION IMPROPRE OU L'USAGE INAPPROPRIÉ DES PRODUITS ET/OU DES SYSTÈMES DÉCRITS AUX PRÉSENTES, OU ARTICLES CONNEXES, PEUVENT ENTRAÎNER LA MORT, DES PRÉJUDICES CORPORELS ET/OU DES DOMMAGES MATÉRIELS.

Le présent document et toute autre information provenant de la Société, de ses filiales et distributeurs agréés se réfèrent à des produits et/ou des systèmes pouvant faire l'objet de tests et de contrôles de la part d'utilisateurs compétents, possédant une expertise technique. Il est important que vous analysiez tous les aspects de votre application, notamment les conséquences d'une défaillance, et étudiez les informations concernant le produit ou les systèmes qui figurent dans le catalogue actuel. Compte tenu de la variété des conditions d'utilisation et des applications inhérentes à ces produits et/ou systèmes, l'utilisateur est, par le biais de ses propres analyses et tests, seul responsable de la sélection finale des produits et/ou systèmes et s'engage à ce que son application réponde à tous les critères relatifs aux performances, à la sécurité et aux mises en garde.

Les produits décrits aux présentes, y compris et sans limitation, les caractéristiques, les spécifications, les conceptions, la disponibilité et les prix, peuvent faire l'objet de modifications par la Société et ses filiales, à tout moment et sans préavis.

FR ATTENTION

Durs et transparents, les bols en polycarbonate sont parfaitement indiqués pour l'utilisation dans les filtres et les lubrificateurs. Ils sont compatibles avec les milieux industriels normaux mais ne doivent pas être placés dans des lieux où ils pourraient être exposés à la lumière directe du soleil, à des chocs ou à des températures situées en-dehors de leur plage d'utilisation nominale. Comme la plupart des plastiques, cette matière peut être endommagée par certains produits chimiques. Les bols en polycarbonate ne doivent pas être exposés aux hydrocarbures chlorés, aux cétones, aux éthers et à certains alcools. Ils ne doivent pas être utilisés dans des systèmes pneumatiques dont les compresseurs sont lubrifiés par des fluides résistants au feu tels que les esters et diesters de phosphate.

Les bols métalliques sont recommandés lorsque le milieu et/ou le fluide sont incompatibles avec les bols en polycarbonate. Les bols métalliques sont résistants à la plupart de ces solvants mais ne doivent pas être utilisés en milieu fortement acide ou basique, ou en atmosphère salée. Si de telles conditions prévalent, adressez-vous au fabricant afin d'obtenir des recommandations spécifiques.

NETTOYER LES BOLS EN POLYCARBONATE UNIQUEMENT À L'EAU ET AU SAVON DOUX ! NE PAS utiliser d'agents nettoyants tels que l'acétone, le benzène, le tétrahlorure de carbone, l'essence, le toluène, etc., qui endommageraient ce plastique.

FR Guide de sécurité

Pour obtenir de plus amples informations sur les directives à appliquer recommandées, prière de vous reporter à la section Guide de sécurité des catalogues de la Pneumatic Division ou de télécharger le Guide de sécurité de la Pneumatic Division sur le site : www.parker.com/safety

FR MISE EN GARDE

Pour éviter que le bol de polycarbonate se rompe et provoque des préjudices corporels ou des dommages matériels, ne pas dépasser les limites maximales de pression et de température, à savoir 150 PSIG (10 bar) et 125 °F (52°C).

DES EXEMPLAIRES DE CES INSTRUCTIONS SONT DISPONIBLES POUR INSERTION DANS LE MATÉRIEL OU LES MANUELS D'ENTRETIEN QUI UTILISENT CES PRODUITS. VEUILLEZ CONTACTER VOTRE REPRÉSENTANT LOCAL.

- UK Individual Product Brackets JP 単体用ブラケット
 CN 单个产品支架 KR 유닛 개별 취부 브라켓
 FR Éléments de fixation pour produits isolés ES Sujeciones producto individual
 IT Staffe separate SE Separata klammer
 DE Spezielle Produkthalterungen

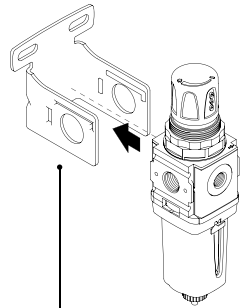

- P31 Mini**
- UK Mounting Bracket
 CN 安装支架
 FR Console
 DE Einbauhalterung
 IT Staffa di montaggio
 JP Cブラケット
 KR C형 취부 브라켓
 ES Sujeción de montaje
 SE Monteringskonsol
- P31KA00MW**

- UK L-Bracket
 CN 角架
 FR Équerre
 DE Winkelhalterung
 IT Staffa angolare
 JP Lブラケット
 KR L형 취부 브라켓
 ES Sujeción angularada
 SE Vinkelklamma
- | | |
|--------------|-----------|
| P32 Compact | P32KA00ML |
| P33 Standard | P33KA00ML |

- UK L-Bracket
 CN 角架
 FR Équerre
 DE Winkelhalterung
 IT Staffa angolare
 JP Lブラケット
 KR L형 취부 브라켓
 ES Sujeción angularada
 SE Vinkelklamma
- UK Torque (JPトルク)
 CN 扭矩 (KR토크크)
 FR Couple (ES) Par
 DE Drehmoment (SE) Moment
- | | | |
|--------------|-----------|--------------------|
| P32 Compact | P32KA00ML | 3.5 Nm (31 lbf-in) |
| P33 Standard | P33KA00ML | 3.7 Nm (33 lbf-in) |

P31 Mini

UK Body Connector JP ポートブロック
 CN 主体接头 KR 바디 컨넥터
 FR Éléments de liaison ES Conector de cuerpo
 DE Gehäusestecker SE Husanslutning
 IT Connettore del corpo

P31KA00CB

UK Port Connector
 CN 接口接头
 FR Raccord
 DE Anschluss-Stutzen
 IT Connettore per porta
 JP 포트블록
 KR 포트블럭
 ES Conectores de bocas
 SE Anslutningsport

UK Body Connector + Wall Mounting Bracket
 CN 主体接头 + 墙壁安装支架
 FR Éléments de liaison + Équerre de fixation murale
 DE Gehäusestecker und Wandhalterung
 IT Connettore del corpo + staffa di montaggio a muro
 JP ボディコネクタ+Tブラケット
 KR 바디 컨넥터 + 취부 브라켓
 ES Conector de cuerpo + Sujeción de muro
 SE Husanslutning + väggfäste

P31KA00MT

UK Port Connector
 CN 接口接头
 FR Raccord
 DE Anschluss-Stutzen
 IT Connettore per porta
 JP 포트블록
 KR 포트블럭
 ES Conectores de bocas
 SE Anslutningsport

0.9 - 1.4 Nm (8-12 lbf-in)
 UK Torque (JPトルク)
 CN 扭矩 (KR토크크)
 FR Couple (ES) Par
 DE Drehmoment (SE) Moment
 IT Coppia

P32 Compact + P33 Standard

2.2 - 2.4 Nm (19-21 lbf-in)
 UK Torque (JPトルク)
 CN 扭矩 (KR토크크)
 FR Couple (ES) Par
 DE Drehmoment (SE) Moment
 IT Coppia

UK Body Connector + Wall Mounting Bracket
 CN 主体接头 + 墙壁安装支架
 FR Éléments de liaison + Équerre de fixation murale
 DE Gehäusestecker und Wandhalterung
 IT Connettore del corpo + staffa di montaggio a muro
 JP ボディコネクタ+Tブラケット
 KR 바디 컨넥터 + 취부 브라켓
 ES Conector de cuerpo + Sujeción de muro
 SE Husanslutning + väggfäste

P32 Compact **P32KA00MT**
P33 Standard **P32KA00MT**

UK Body Connector
 CN 主体接头
 FR Éléments de liaison
 DE Gehäusestecker
 IT Connettore del corpo
 JP 포트블록
 KR 바디 컨넥터
 ES Conector de cuerpo
 SE Husanslutning

P32 Compact **P32KA00CB**
P33 Standard **P32KA00CB**

UK Manifold Block
 CN 分气块
 FR Bloc d'îlots
 DE Sammelsystemeiste
 IT Blocco manifold
 JP マニホールドブロック
 KR 매니폴드 블록
 ES Bloque de manifold
 SE Anslutningsblock

2.2 - 2.4 Nm (19-21 lbf-in)
 UK Torque (JPトルク)
 CN 扭矩 (KR토크크)
 FR Couple (ES) Par
 DE Drehmoment (SE) Moment
 IT Coppia

- UK Regulator + Filter/Regulator Angle Bracket
 CN 单个产品支架
 FR Équerre pour Régulateur + Filtre/Régulateur
 DE Winkelhalterung für Regler + Filter/Regler
 IT Staffa angolare per regolatore + filtro/regolatore
 JP 単体用ブラケット
 KR 유닛 개별 취부 브라켓
 ES Sujeción angularada Regulator + Filtro/Regulator
 SE Regulator + vinkelramma för filter/regulator

- UK Panel Mounting Ring
 CN 面板安装螺母
 FR Écrou pour montage sur panneau
 DE Schalttafel-Schraubring
 IT Anello di montaggio su pannello
- JP パネルマウントリング
 KR 판넬 마운팅 너트
 ES Aro de montaje en panel
 SE Ring för panelmontering

UK Plastic Nut CN 塑料螺母 FR Écrou en plastique DE Kunststoffmutter IT Dado in plastica JP プラスチックナット KR 플라스틱 너트 ES Tuerca plástica SE Plastmutter	UK Metal Nut CN 金属螺母 FR Écrou métallique DE Metallmutter IT Dado in metallo JP アルミニウムナット KR 네탈 너트 ES Tuerca metálica SE Metallmutter	
P31 Mini	P31KA00MP	P31KA00MM
P32 Compact	P32KA00MP	P32KA00MM
P33 Standard	P33KA00MP	P33KA00MM

UK Angle Bracket
 CN 角架
 FR Équerre
 DE Winkelhalterung
 IT Staffa angolare
 JP アングルブラケット
 KR L형 취부 브라켓
 ES Sujeción angularada
 SE Vinkelklamma

P31 Mini	P31KA00MR
P32 Compact	P32KA00MR
P33 Standard	P33KA00MR

⚠ WARNING

To avoid unpredictable system behavior that can cause personal injury and property damage:

- Disconnect electrical supply (when necessary) before installation, servicing, or conversion.
- Disconnect air supply and depressurize all air lines connected to this product before installation, servicing, or conversion.
- Operate within the manufacturer's specified pressure, temperature, and other conditions listed in these instructions.
- Medium must be moisture-free if ambient temperature is below freezing.
- Service according to procedures listed in these instructions.
- Installation, service, and conversion of these products must be performed by knowledgeable personnel who understand how pneumatic products are to be applied.
- After installation, servicing, or conversion, air and electrical supplies (when necessary) should be connected and the product tested for proper function and leakage. If audible leakage is present, or the product does not operate properly, do not put into use.
- Warnings and specifications on the product should not be covered by paint, etc. If masking is not possible, contact your local representative for replacement labels.

⚠ CAUTION

Polycarbonate bowls, being transparent and tough, are ideal for use with Filters and Lubricators. They are suitable for use in normal industrial environments, but should not be located in areas where they could be subjected to direct sunlight, an impact blow, nor temperatures outside of the rated range. As with most plastics, some chemicals can cause damage. Polycarbonate bowls should not be exposed to chlorinated hydrocarbons, ketones, esters and certain alcohols. They should not be used in air systems where compressors are lubricated with fire-resistant fluids such as phosphate ester and di-ester types.

Metal bowls are recommended where ambient and/or media conditions are not compatible with polyurethane bowls. Metal bowls resist the action of most such solvents, but should not be used where strong acids or bases are present or in salt laden atmospheres. Consult the factory for specific recommendations where these conditions exist.

TO CLEAN POLYCARBONATE BOWLS USE MILD SOAP AND WATER ONLY! DO NOT use cleansing agents such as acetone, benzene, carbon tetrachloride, gasoline, toluene, etc., which are damaging to this plastic.

Safety Guide

For more complete information on recommended application guidelines, see the Safety Guide section of Pneumatic Division catalogs or you can download the **Pneumatic Division Safety Guide** at: www.wattsfluidair.com

Introduction

Follow these instructions when installing, operating, or servicing the product.

Application Limits

These products are intended for use in general purpose compressed air systems only.

Maximum Recommended Pressure Drop:

	kPa	PSIG	bar
Particulate Filter	70	10	0.7

With Polycarbonate Bowl

	kPa	PSIG	bar
Operating Pressure Maximum	1034	150	10
Operating Temperature Range	4°C to 49°C (40°F to 120°F)		

With Aluminum Bowl

	kPa	PSIG	bar
Operating Pressure Maximum	2068	300	21
Operating Temperature Range	4°C to 82°C (40°F to 180°F)		

With Zinc Bowl with Sight Gauge

	kPa	PSIG	bar
Operating Pressure Maximum	1723	250	17.0
Operating Temperature Range	4°C to 66°C (40°F to 150°F)		

ANSI Symbols

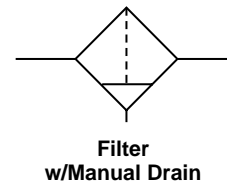

⚠ WARNING

FAILURE OR IMPROPER SELECTION OR IMPROPER USE OF THE PRODUCTS AND/OR SYSTEMS DESCRIBED HEREIN OR RELATED ITEMS CAN CAUSE DEATH, PERSONAL INJURY AND PROPERTY DAMAGE.

This document and other information from The Company, its subsidiaries and authorized distributors provide product and/or system options for further investigation by users having technical expertise. It is important that you analyze all aspects of your application, including consequences of any failure and review the information concerning the product or systems in the current product catalog. Due to the variety of operating conditions and applications for these products or systems, the user, through its own analysis and testing, is solely responsible for making the final selection of the products and systems and assuring that all performance, safety and warning requirements of the application are met.

The products described herein, including without limitation, product features, specifications, designs, availability and pricing, are subject to change by The Company and its subsidiaries at any time without notice.

EXTRA COPIES OF THESE INSTRUCTIONS ARE AVAILABLE FOR INCLUSION IN EQUIPMENT / MAINTENANCE MANUALS THAT UTILIZE THESE PRODUCTS. CONTACT YOUR LOCAL REPRESENTATIVE.

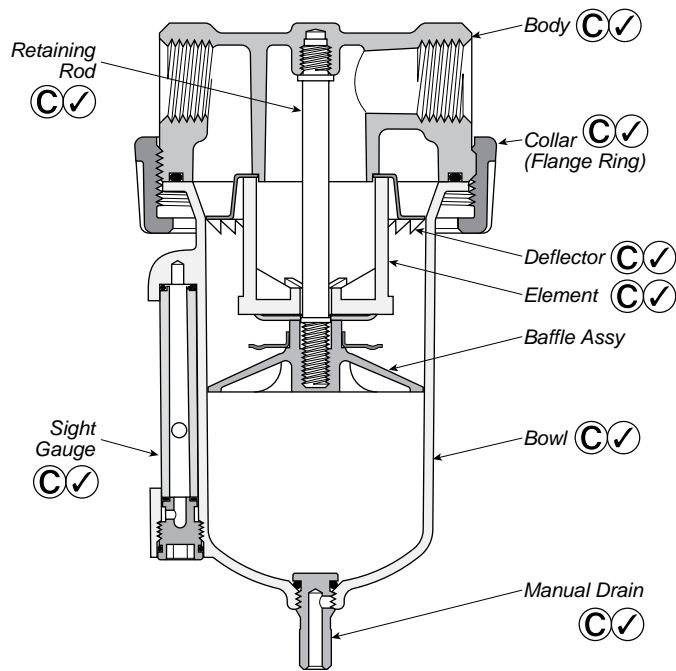

- Ⓒ Lightly grease with provided lubricant.
- ✓ Inspect for nicks, scratches, and surface imperfections. If present, reduced service life is probable and future replacement should be planned.
- Ⓒ Clean with lint-free cloth.

Installation

1. The filter should be installed with reasonable accessibility for service whenever possible – repair service kits are available. Keep pipe or tubing lengths to a minimum with inside clean and free of dirt and chips. Pipe joint compound should be used sparingly and applied only to the male pipe – never into the female port. Do not use PTFE tape to seal pipe joints – pieces have a tendency to break off and lodge inside the unit, possibly causing malfunction. Also, new pipe or hose should be installed between the filter and equipment being protected.
2. The upstream pipe work must be clear of accumulated dirt and liquids.
3. Select a filter location as close as possible to the equipment being protected and upstream of any pressure regulator.
4. Install filter so that air flows in the direction of arrow on body.
5. Install filter vertically with bowl drain mechanism at the bottom. Free moisture will thus drain into the sump “quiet zone” at the bottom of the bowl.

Operation and Service

1. To service the filter, it is not necessary to remove the unit from the airline. Manual drain filters must be drained regularly before the separated moisture and oil reaches the bottom of the lower baffle.
2. The particulate Filter Element should be removed and replaced when pressure differential across the filter is 10 PSIG.
3. Shut off air supply and depressurize the unit, before servicing.
4. Carefully remove Bowl by turning counterclockwise.
5. Remove Filter Element, Baffle, and Retainer.
6. Wipe parts, clean with soapy water or denatured alcohol, **but do not use denatured alcohol on plastic bowl or sight gauge.** If using compressed air to blow dry, be sure to wear appropriate eye protection.
7. After servicing, apply system pressure and check for air leaks. If leakage occurs, **Do Not Operate** — conduct servicing again.

Kits Available

Description	Product Number	Bowl Type	Port Size
Bowls			
Polycarbonate	BK602Y	B	1/4", 3/8"
Zinc with Sight Gauge	BK605WY	W	1/4", 3/8"
Polycarbonate	BK602A	B	1/2"
Aluminum	BK603A	E	1/2"
Zinc with Sight Gauge	BK605WA	W	1/2"
Aluminum	BK603B	E	3/4" thru 2-1/2"
Zinc with Sight Gauge	BK605WB	W	3/4" thru 2-1/2"
Element Kits			
5 Micron	EK602VY	—	1/4", 3/8"
40 Micron	EK602Y	—	1/4", 3/8"
5 Micron	EK602VA	—	1/2"
40 Micron	EK602A	—	1/2"
5 Micron	EK602VB	—	3/4" thru 1-1/2"
40 Micron	EK602B	—	3/4" thru 1-1/2"
5 Micron Bronze	EK602VB-BR	—	3/4" thru 1-1/2"
40 Micron Bronze	EK602B-BR	—	3/4" thru 1-1/2"
40 Micron	EK602G	—	2", 2-1/2"
Drain Kits			
Manual	SA600Y7-1	All	All Sizes
Piston (Poly Bowl Only)	RK602SY	B	1/4", 3/8"
Piston (Poly Bowl Only)	RK602SA	B	1/2"
External Auto. (8 oz. Poly & Metal)	SA602D	B	1/2"
External Auto. (16 oz. Aluminum)	SA603D	E	1/2"
Internal Auto.	SA602MD	All	1/2"
External Auto. (16 oz. Metal Bowl)	SA602D	W	3/4" thru 2-1/2"
External Auto. (32 oz. Aluminum)	SA603D	E	3/4" thru 2-1/2"
Internal Auto.	SA602MD	All	3/4" thru 2-1/2"
Mounting Bracket Kits			
	SAF602-0571	—	1/4", 3/8"
	SAF602-0572	—	1/2"
(2 per unit required)	SA200AW57	—	3/4"
(2 per unit required)	SA200CW57	—	1"
Repair Kits			
Deflector, Baffle Assy, Retaining Rod	RK602Y	—	1/4", 3/8"
Deflector, Baffle Assy, Retaining Rod	RK602A	—	1/2"
Deflector, Baffle Assy, Retaining Rod	RK602B	—	3/4", 1"
Deflector, Baffle Assy, Retaining Rod	RK602C	—	1-1/4", 1-1/2"
Deflector, Baffle Assy, Retaining Rod	RK602G	—	2", 2-1/2"
External Auto Drain (Short Float 602)	RK602D	—	1/2" thru 2-1/2"
External Auto Drain (Tall Float 603)	RK603D	—	1/2" thru 2-1/2"
Internal Auto Drain	RK602MD	—	1/4" thru 2-1/2"
Metal Bowl with Sight Gauge	RKB605WY	—	1/4", 3/8"
Metal Bowl with Sight Gauge	RKB605WA	—	1/2"

Fixation - Mounting - Befestigung - Fijacion - Fissaggio



- UK** Disconnect air & electrical supplies before attempting repair or maintenance See ISO4414 for safety requirements covering the installation and use of pneumatic equipment.
- FR** Débrancher les connexions pneumatiques et électriques avant réparation ou maintenance. Voir ISO4414 pour les règles de sécurité des installations et utilisation des équipements pneumatiques.
- DE** Bei Reparatur - oder Wartungsarbeiten sind alle pneumatischen und elektrischen Versorgungsleitungen zuvor vom Zylinder zu trennen. Siehe ISO4414 bzw. DIN 24 558 bezüglich Sicherheits-Anforderungen für den Bereich Installation und Gebrauch von Pneumatik-Komponenten.
- SE** Koppla ifrån luft och elektriska anslutningar innan reparation- eller underhållsarbeten påbörjas. Se ISO4414 för säkerhetsbestämmelser täckande installation och användande av pneumatisk utrustning.
- ES** Desconectar las conexiones neumáticas y eléctricas antes de efectuar cualquier reparación o mantenimiento. Ver ISO4414 para reglas de seguridad de las instalaciones y utilización de equipos neumáticos.
- IT** Prima di eseguire interventi di manutenzione verificare che sia l'alimentazione elettrica che pneumatica siano disattivate. Attenersi alla normativa ISO4414 che regola l'installazione e l'uso di componenti pneumatici.

Coupling Kit
Kupplungssatz

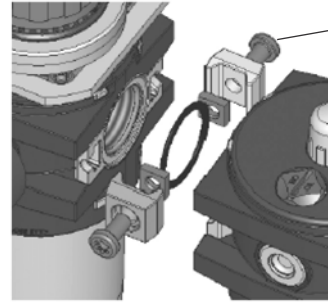

P3YKA00CB

Association - Combination - Verbindung - Asociacion - Assemblaggio

WARNING

To avoid unpredictable system behavior that can cause personal injury and proper damage:

- Disconnect electrical supply (when necessary) before installation, servicing, or conversion.
- Disconnect air supply and depressurize all air lines connected to this product before installation, servicing or conversion.
- Operate within the manufacturer's specified pressure, temperature, and other conditions listed in these instructions.
- Medium must be moisture-free if ambient temperature is below freezing.
- Service according to procedures listed in these instructions.
- Installation, service and conversion of these products must be performed by knowledgeable personnel who understand how pneumatic products are to be applied.
- After installation, servicing or conversion, air and electrical supplies (when necessary) should be connected and the product tested for proper function and leakage. If audible leakage is present or the product does not operate properly, do not put into use.
- Warning and specifications on the product should not be covered by paint, etc. If masking is not possible, contact your local representative for replacement labels.

WARNING

Product rupture can cause serious injury.
Do not connect regulator to bottled gas.
Do not exceed maximum primary pressure rating.

WARNING

FAILURE OR IMPROPER SELECTION OR IMPROPER USE OF THE PRODUCTS AND/OR SYSTEMS DESCRIBED HEREIN OR RELATED ITEMS CAN CAUSE DEATH, PERSONAL INJURY AND PROPERTY DAMAGE.

This document and other information from the Company, its subsidiaries and authorized distributors provide product and/or system options for further investigation by users having technical expertise. It is important that you analyze all aspects of your application, including consequences of any failure and review the information concerning the product or systems in the current product catalogue. Due to the variety of operating conditions and applications for these products or systems, the user, through its own analysis and testing, is solely responsible for making the final selection of the products and systems and assuring that all performance, safety and warning requirements of the application are met.

The products described herein, including without limitation, product features, specifications, designs, availability and pricing, are subject to change by The Company and its subsidiaries at any time without notice.



Réglage - Adjustment - Steuerung - Regulacion - Regolazione

Service kits

Diaphragm kit - relieving type = **P3YKA00RR**

Diaphragm kit - non-relieving type = **P3YKA00RN**

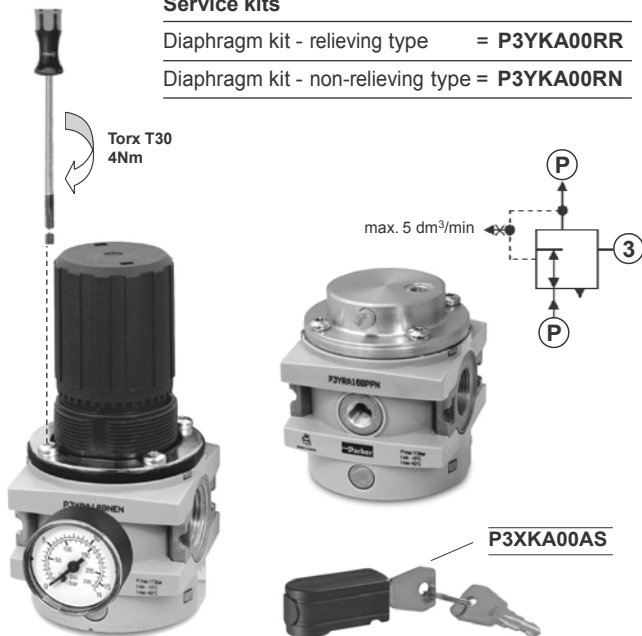

Connector M12 x 1

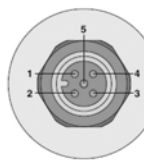

Pin 1:
Power supply
Plus +24 V DC ± 10%
0.15 A
Residual ripple 10%

Pin 2:
Power supply 0 V
Reference and mass capacity
for set value and actual value

Pin 3:
Set value output
0-10 V

Pin 4:
0 V target signal
(connected on board
with pin 2 as standard)

Pin 5:
Analog actual value output
0-10 V
Tolerance ± 0.15 V

Analog voltage

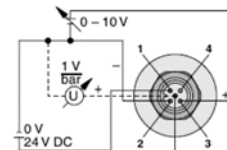

PLC in connection with several potentiometers

With a single potentiometer

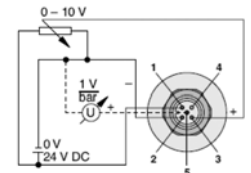

The resistance of the potentiometer should range between 500 Ω and 100 Ω

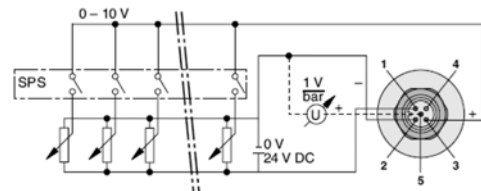

The total resistance of the potentiometer series should not be less than 500 Ω

Filter Maintenance - Maintenance du filtre - Wartung - Mantenimiento - Manutenzione

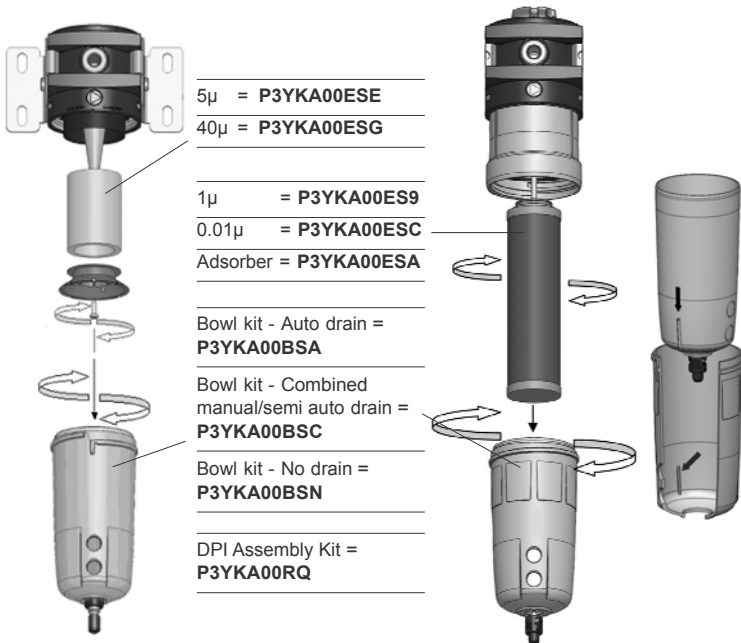

Condensate drainage / Purge / Kondensatentleerung / Svuotamento condensati / Vaciado del condensado / odpouštění kondenzátu / spust kondensatu

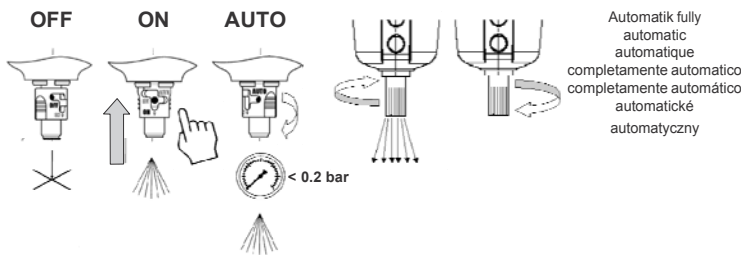

Lubricator Adjustment - Réglage du lubrificateur - Steuerung Regulacion - Regolazione

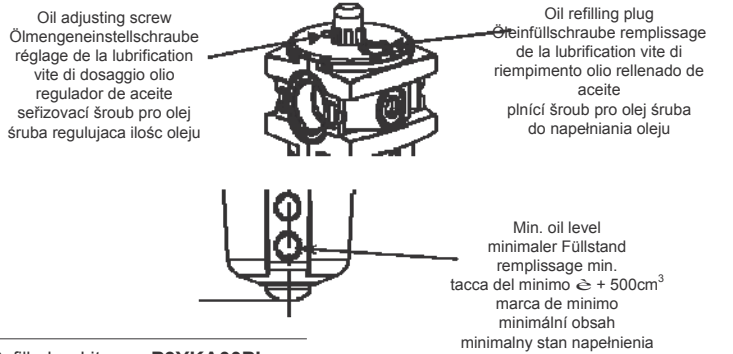

Refill plug kit = P3YKA00PL
Oil VG32 1L = P3YKA00PPBB

Recommended Lubricants / Lubrifiants recommandés / Empfohlene Ölsorten / Lubrificantii consigliati / Lubrificantes recomendados / Rekommenderade oljor för dimsmörjare

Lubrication of airlines

Oil Company	ISO Grade	Grade	ISO Grade	Grade
Gulf	Harmony 38AW	15	Harmony 43AW	32
Shell (UK) Oil	Tellus 22	22	Tellus 37	37
Burmah Castrol	Hyspin AWS15	15	Hyspin AWS32	32
Edgar Vaughan	KSO 5L	10	Hydrodrive HP100	32
Esso Petroleum	NUTO 1115	15	NUTO H32	32
B.P.	HLP 22	22	HLP 32	32
Mobile Oil Company	Velocite No.6	10	DTE Oil - Light	32
Shell	Cassida Fluid HF*	32		
Klüberoil	4UH1*	32		

* For food industry applications : approved oil USDA-H1

Do not use oils with additives, compounds oils containing solvents, graphite, detergents.
The use of synthetic oils and antifreeze with a Glycol concentration of 100% can be used.

Combined Soft Start & Dump Valve / Soft Start Valve / Vannes de mise en pression progressive et de purge / Sanftanlauf + Abschalt-Ventile / Mjukstartventiler / Válvulas de arranque progresivo / Valvole Avviamento Progressivo

The allen key adjusts flow through the valve until the set point is reached, after which full pressure is achieved.

Le débit est réglable par la clé Allen, jusqu'à la valeur consigne qui déclenche le plein passage

Mjukstartsflödet kan justeras med insexnyckel. Vid uppnått omställningstryck öppnar sedan ventilen för fullt flöde.

Utilizar la Llave Allen para regular el caudal de la válvula hasta lograr la presión tarada - de esta forma se proporciona el flujo máximo de aire.

La chiave Allen regola il flusso attraverso la valvola fino al raggiungimento del valore impostato, quindi viene inserita la pressione totale.

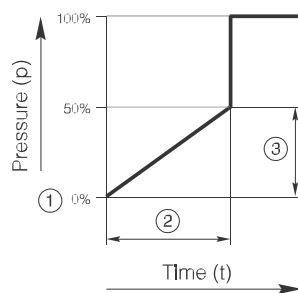

Soft start is 50% pressure dependant on P1

- Start signal
Démarrage
Start-Signal
Startsignal
Señal de arranque
Segnale di start
- Switching time delay
Signal temporisé
Schaltzeit-Verzögerung
Omställningstid
Tiempo de arranque
Ritardo commutazione
- Gradual pressure build up
Mise en pression progressive
Allmählicher Druckaufbau
Uppbyggnadstryck
Aumento gradual de la presión
Incremento graduale della pressione
- Operating pressure $p^2 (=p^1)$
Pression de fonctionnement $p^2 (=p^1)$
Betriebsdruck $p^2 (=p^1)$
Arbetsstryck $p^2 (=p^1)$
Presión de funcionamiento $p^2 (=p^1)$
Pressione di esercizio $p^2 (=p^1)$

Combined start/stop function

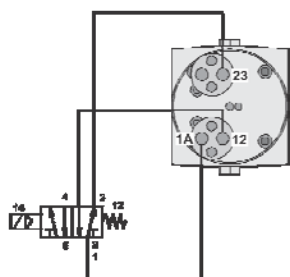

Combined start/stop function with acknowledgement

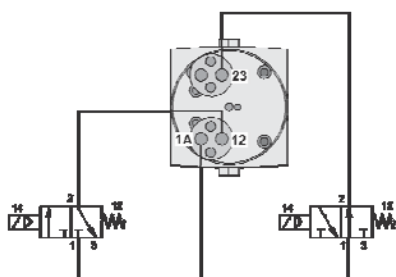

Ball Valve

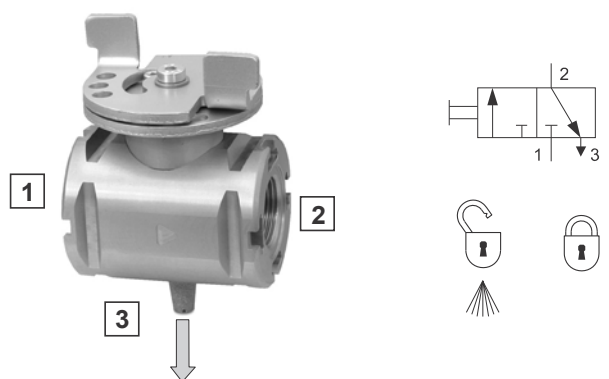



Pneumatic Division
Richland, Michigan 49083
269-629-5000

PDNSG-1

Pneumatic Division Safety Guide

ISSUED: August 1, 2006

Supersedes: June 1, 2006

Safety Guide For Selecting And Using Pneumatic Division Products And Related Accessories

⚠ WARNING:

FAILURE OR IMPROPER SELECTION OR IMPROPER USE OF PNEUMATIC DIVISION PRODUCTS, ASSEMBLIES OR RELATED ITEMS ("PRODUCTS") CAN CAUSE DEATH, PERSONAL INJURY, AND PROPERTY DAMAGE. POSSIBLE CONSEQUENCES OF FAILURE OR IMPROPER SELECTION OR IMPROPER USE OF THESE PRODUCTS INCLUDE BUT ARE NOT LIMITED TO:

- Unintended or mistimed cycling or motion of machine members or failure to cycle
- Work pieces or component parts being thrown off at high speeds.
- Failure of a device to function properly for example, failure to clamp or unclamp an associated item or device.
- Explosion
- Suddenly moving or falling objects.
- Release of toxic or otherwise injurious liquids or gasses.

Before selecting or using any of these Products, it is important that you read and follow the instructions below.

1. GENERAL INSTRUCTIONS

- 1.1. Scope:** This safety guide is designed to cover general guidelines on the installation, use, and maintenance of Pneumatic Division Valves, FRLs (Filters, Pressure Regulators, and Lubricators), Vacuum products and related accessory components.
- 1.2. Fail-Safe:** Valves, FRLs, Vacuum products and their related components can and do fail without warning for many reasons. Design all systems and equipment in a fail-safe mode, so that failure of associated valves, FRLs or Vacuum products will not endanger persons or property.
- 1.3. Relevant International Standards:** For a good guide to the application of a broad spectrum of pneumatic fluid power devices see: ISO 4414:1998, Pneumatic Fluid Power – General Rules Relating to Systems. See www.iso.org for ordering information.
- 1.4. Distribution:** Provide a copy of this safety guide to each person that is responsible for selection, installation, or use of Valves, FRLs or Vacuum products. Do not select, or use Parker valves, FRLs or vacuum products without thoroughly reading and understanding this safety guide as well as the specific Parker publications for the products considered or selected.
- 1.5. User Responsibility:** Due to the wide variety of operating conditions and applications for valves, FRLs, and vacuum products Parker and its distributors do not represent or warrant that any particular valve, FRL or vacuum product is suitable for any specific end use system. This safety guide does not analyze all technical parameters that must be considered in selecting a product. The user, through its own analysis and testing, is solely responsible for:
 - Making the final selection of the appropriate valve, FRL, Vacuum component, or accessory.
 - Assuring that all user's performance, endurance, maintenance, safety, and warning requirements are met and that the application presents no health or safety hazards.
 - Complying with all existing warning labels and / or providing all appropriate health and safety warnings on the equipment on which the valves, FRLs or Vacuum products are used; and,
 - Assuring compliance with all applicable government and industry standards.
- 1.6. Safety Devices:** Safety devices should not be removed, or defeated.
- 1.7. Warning Labels:** Warning labels should not be removed, painted over or otherwise obscured.
- 1.8. Additional Questions:** Call the appropriate Parker technical service department if you have any questions or require any additional information. See the Parker publication for the product being considered or used, or call 1-800-CPARKER, or go to www.parker.com, for telephone numbers of the appropriate technical service department.

2. PRODUCT SELECTION INSTRUCTIONS

- 2.1. Flow Rate:** The flow rate requirements of a system are frequently the primary consideration when designing any pneumatic system. System components need to be able to provide adequate flow and pressure for the desired application.
- 2.2. Pressure Rating:** Never exceed the rated pressure of a product. Consult product labeling, Pneumatic Division catalogs or the instruction sheets supplied for maximum pressure ratings.
- 2.3. Temperature Rating:** Never exceed the temperature rating of a product. Excessive heat can shorten the life expectancy of a product and result in complete product failure.
- 2.4. Environment:** Many environmental conditions can affect the integrity and suitability of a product for a given application. Pneumatic Division products are designed for use in general purpose industrial applications. If these products are to be used in unusual circumstances such as direct sunlight and/or corrosive or caustic environments, such use can shorten the useful life and lead to premature failure of a product.
- 2.5. Lubrication and Compressor Carryover:** Some modern synthetic oils can and will attack nitrile seals. If there is any possibility of synthetic oils or greases migrating into the pneumatic components check for compatibility with the seal materials used. Consult the factory or product literature for materials of construction.
- 2.6. Polycarbonate Bowls and Sight Glasses:** To avoid potential polycarbonate bowl failures:
 - Do not locate polycarbonate bowls or sight glasses in areas where they could be subject to direct sunlight, impact blow, or temperatures outside of the rated range.
 - Do not expose or clean polycarbonate bowls with detergents, chlorinated hydro-carbons, ketones, esters or certain alcohols.
 - Do not use polycarbonate bowls or sight glasses in air systems where compressors are lubricated with fire resistant fluids such as phosphate ester and di-ester lubricants.

Pneumatic Division Safety Guide

2.7. Chemical Compatibility: For more information on plastic component chemical compatibility see Pneumatic Division technical bulletins Tec-3, Tec-4, and Tec-5

2.8. Product Rupture: Product rupture can cause death, serious personal injury, and property damage.

- Do not connect pressure regulators or other Pneumatic Division products to bottled gas cylinders.
- Do not exceed the maximum primary pressure rating of any pressure regulator or any system component.
- Consult product labeling or product literature for pressure rating limitations.

3. PRODUCT ASSEMBLY AND INSTALLATION INSTRUCTIONS

3.1. Component Inspection: Prior to assembly or installation a careful examination of the valves, FRLs or vacuum products must be performed. All components must be checked for correct style, size, and catalog number. DO NOT use any component that displays any signs of nonconformance.

3.2. Installation Instructions: Parker published Installation Instructions must be followed for installation of Parker valves, FRLs and vacuum components. These instructions are provided with every Parker valve or FRL sold, or by calling 1-800-CPARKER, or at www.parker.com.

3.3. Air Supply: The air supply or control medium supplied to Valves, FRLs and Vacuum components must be moisture-free if ambient temperature can drop below freezing

4. VALVE AND FRL MAINTENANCE AND REPLACEMENT INSTRUCTIONS

4.1. Maintenance: Even with proper selection and installation, valve, FRL and vacuum products service life may be significantly reduced without a continuing maintenance program. The severity of the application, risk potential from a component failure, and experience with any known failures in the application or in similar applications should determine the frequency of inspections and the servicing or replacement of Pneumatic Division products so that products are replaced before any failure occurs. A maintenance program must be established and followed by the user and, at minimum, must include instructions 4.2 through 4.10.

4.2. Installation and Service Instructions: Before attempting to service or replace any worn or damaged parts consult the appropriate Service Bulletin for the valve or FRL in question for the appropriate practices to service the unit in question. These Service and Installation Instructions are provided with every Parker valve and FRL sold, or are available by calling 1-800-CPARKER, or by accessing the Parker web site at www.parker.com.

4.3. Lockout / Tagout Procedures: Be sure to follow all required lockout and tagout procedures when servicing equipment. For more information see: OSHA Standard – 29 CFR, Part 1910.147, Appendix A, The Control of Hazardous Energy – (Lockout / Tagout)

4.4. Visual Inspection: Any of the following conditions requires immediate system shut down and replacement of worn or damaged components:

- Air leakage: Look and listen to see if there are any signs of visual damage to any of the components in the system. Leakage is an indication of worn or damaged components.
- Damaged or degraded components: Look to see if there are any visible signs of wear or component degradation.
- Kinked, crushed, or damaged hoses. Kinked hoses can result in restricted air flow and lead to unpredictable system behavior.
- Any observed improper system or component function: Immediately shut down the system and correct malfunction.
- Excessive dirt build-up: Dirt and clutter can mask potentially hazardous situations.

Caution: Leak detection solutions should be rinsed off after use.

4.5. Routine Maintenance Issues:

- Remove excessive dirt, grime and clutter from work areas.
- Make sure all required guards and shields are in place.

4.6. Functional Test: Before initiating automatic operation, operate the system manually to make sure all required functions operate properly and safely.

4.7. Service or Replacement Intervals: It is the user's responsibility to establish appropriate service intervals. Valves, FRLs and vacuum products contain components that age, harden, wear, and otherwise deteriorate over time. Environmental conditions can significantly accelerate this process. Valves, FRLs and vacuum components need to be serviced or replaced on routine intervals. Service intervals need to be established based on:

- Previous performance experiences.
- Government and / or industrial standards.
- When failures could result in unacceptable down time, equipment damage or personal injury risk.

4.8. Servicing or Replacing of any Worn or Damaged Parts: To avoid unpredictable system behavior that can cause death, personal injury and property damage:

- Follow all government, state and local safety and servicing practices prior to service including but not limited to all OSHA Lockout Tagout procedures (OSHA Standard – 29 CFR, Part 1910.147, Appendix A, The Control of Hazardous Energy – Lockout / Tagout).
- Disconnect electrical supply (when necessary) before installation, servicing, or conversion.
- Disconnect air supply and depressurize all air lines connected to system and Pneumatic Division products before installation, service, or conversion.
- Installation, servicing, and / or conversion of these products must be performed by knowledgeable personnel who understand how pneumatic products are to be applied.
- After installation, servicing, or conversions air and electrical supplies (when necessary) should be connected and the product tested for proper function and leakage. If audible leakage is present, or if the product does not operate properly, do not put product or system into use.
- Warnings and specifications on the product should not be covered or painted over. If masking is not possible, contact your local representative for replacement labels.

4.9. Putting Serviced System Back into Operation: Follow the guidelines above and all relevant Installation and Maintenance Instructions supplied with the valve FRL or vacuum component to insure proper function of the system.