

Spindle Servomotors

SKW Series

Technical Manual

PVD3671-GB-SKW





EU DECLARATION OF CONFORMITY

We ,

Parker Hannifin Manufacturing France SAS
Electromechanical & Drives Division Europe
Etablissement de Longvic
4 Boulevard Eiffel - CS40090
21604 LONGVIC Cedex - France

manufacturer, with brand name **Parker**, declare under our sole responsibility that the products

SERVOMOTORS TYPE SKW

satisfy the arrangements of the directives :

Directive 2014/35/EU : “Low Voltage Directive”, LVD
Directive 2011/65/EU : “Restriction of Hazardous Substances”, RoHS
Directive 2014/30/EU : “Electromagnetic Compatibility”, EMC

and meet standards or normative document according to :

EN 60034-1:2010/AC:2010 : Rotating electrical machines - Part 1 : Rating and performance.
EN 60034-5:2001/A1:2007 : Rotating electrical machines - Part 5 : Degrees of protection provided by the integral design of rotating electrical machines (IP code) - Classification.
EN 60204-1:2006/AC:2010 : Safety of machinery – Electrical equipment of machines – Part 1 : General requirements.

The product itself is not impacted by the modifications made on the latest directives.

The undersigned certify that the above mentioned model is procured in accordance with the above directives and standards.

Further information :

SERVOMOTORS shall be mounted on a mechanical support providing good heat conduction and not exceeding 40° C in the vicinity of the motor flange.

As SKW is a kit motor, final conformance of the complete motor is under the responsibility of the integrator.

The product must be installed in accordance with the instructions and recommendations contained in the operating instructions supplied with the product.

SKW C.E. Marking : November 03rd 2008

Longvic, November 18th 2016

In the name of Parker
A. ANDRIOT
Quality Manager

Ref : DCE-SKW-001rev0



Table of Content

1. INTRODUCTION	5
1.1. Purpose and intended audience	5
1.2. Safety	5
1.2.1. Principle	5
1.2.2. General Safety Rules	6
2. PRODUCT DESCRIPTION	7
2.1. Quick URL	7
2.2. Overview	7
2.3. Motor description and Applications	7
2.4. General Technical Data	9
2.5. Product Code	10
3. TECHNICAL DATAS	11
3.1. Motor selection	11
3.1.1. Altitude derating	11
3.1.2. Temperature derating	11
3.1.3. Thermal equivalent torque (rms torque)	12
3.1.4. Drive selection	14
3.1.5. Current limitation at stall conditions (i.e. speed < 3 rpm)	15
3.1.6. Peak current limitations	15
3.2. SKW Characteristics: Torque, speed, current, power	16
3.2.1. SKW data with water cooling – Mains voltage 400V	16
3.2.2. Further Data	17
3.2.3. Time constants of the motor	18
3.2.4. Voltage withstand characteristics of SKW series	20
3.3. Dimension drawings	21
3.3.1. SKW073****R3000	21
3.3.2. SKW082****R3000	22
3.3.3. SKW091****R3000	23
3.3.4. SKW096****R3000	24
3.4. Motor mounting recommendations	25
3.4.1. Frame recommendation	25
3.4.2. Motor flanges	26
3.4.3. Cooling jacket interface SKW**** R3000	27
3.4.4. Shaft interface for SKW	28
3.4.5. O-ring Specification	29
3.4.6. Condensation water drain hole	29
3.4.7. Design Compliance	30
3.4.8. Dielectric test	30
3.4.9. Earthing	30
3.4.10. Minimum clearances for insulation and creepage distances	30
3.4.1. Ground continuity compliance	31
3.4.2. Ground continuity compliance	31
3.4.3. Protection rating	31
3.4.4. Overspeed test	32
3.4.5. EMC Directive	32
3.4.6. Other requirements	32
3.5. Cooling	33
3.5.1. Water cooled motor – SKW series	33
3.5.2. Additives for water as cooling media	34
3.5.3. Motor cooling circuit data	35
3.5.4. Chiller selection	35
3.5.5. Flow derating according to glycol concentration	36
3.5.6. Water cooling diagram	38
3.6. Thermal Protection	40
3.6.1. Alarm tripping with PTC thermistors :	40
3.6.2. Temperature measurement with KTY sensors:	41
3.7. 41	
3.8. Power electrical connections	42
3.8.1. Wires sizes	42
3.8.2. Conversion Awg/kcmil/mm ² :	43
3.8.3. Motor cable length	44



3.8.4.	Ground connection	44
3.8.5.	Motor cable	44
4.	COMMISSIONING AND USE.....	46
4.1.	Instructions for commissioning and use	46
4.1.1.	Equipment delivery	46
4.1.2.	Handling	46
4.1.3.	Storage	46
4.2.	Machine integration	47
4.2.1.	General warnings	47
4.2.2.	Tightening torque.....	48
4.2.3.	Rotor integration step by step	49
4.2.4.	Stator integration step by step.....	53
4.2.5.	Rotor assembly into stator step by step	55
4.3.	Electrical connections	58
4.4.	Encoder cable handling.....	60
4.5.	Tests.....	61
4.6.	Troubleshooting	62

1. INTRODUCTION

1.1. Purpose and intended audience

This manual contains information that must be observed to select, install, operate and maintain PARKER SKW high speed motors in kit.

The design, tests, certification, commissioning, operation and maintenance of the equipment should be carried out by qualified personnel. A qualified person is someone who is technically competent and familiar with all safety information and established safety practices; with the installation process, operation and maintenance of this equipment; and with all the hazards involved.

Reading and understanding the information described in this document is mandatory before carrying out any operation on the motors. If any malfunction or technical problem occurs, that has not been dealt with in this manual, please contact PARKER for technical assistance. In case of missing information or doubts regarding the installation procedures, safety instructions or any other issue tackled in this manual, please contact PARKER as well.

PARKER's responsibility is limited to its torque motors and does not encompass the whole user's system. Data provided in this manual are for product description only and may not be guaranteed, unless expressly mentioned in a contract.



DANGER: PARKER declines responsibility for any accident or material damage that may arise, if the procedures and safety instructions described in this manual are not scrupulously followed.

1.2. Safety





1.2.1. Principle

To operate safely, this equipment must be transported, stored, handled, installed and serviced correctly. Following the safety instructions described in each section of this document is mandatory. Torque Motors usage must also comply with all applicable standards, national directives and factory instructions in force.



DANGER: Non-compliance with safety instructions, legal and technical regulations in force may lead to physical injuries or death, as well as damages to the property and the environment.

1.2.2. General Safety Rules

	<p>Generality DANGER: The installation, commission and operation must be performed by qualified personnel, in conjunction with this documentation.</p> <p>The qualified personnel must know the safety (C18510 authorization, standard VDE 0105 or IEC 0364) and local regulations.</p> <p>They must be authorized to install, commission and operate in accordance with established practices and standards.</p>
	<p>Electrical hazard Servo drives may contain non-insulated live AC or DC components. Respect the drives commissioning manual. Users are advised to guard against access to live parts before installing the equipment.</p> <p>Some parts of the motor or installation elements can be subjected to dangerous voltages, when the motor is driven by the inverter , when the motor rotor is manually rotated, when the motor is driven by its load, when the motor is at standstill or stopped.</p> <p>For measurements use only a meter to IEC 61010 (CAT III or higher). Always begin using the highest range. CAT I and CAT II meters must not be used on this product.</p> <p>Allow at least 5 minutes for the drive's capacitors to discharge to safe voltage levels (<50V). Use the specified meter capable of measuring up to 1000V dc & ac rms to confirm that less than 50V is present between all power terminals and between power terminals and earth.</p> <p>The motor must be permanently connected to an appropriate safety earth. The continuity of the grounding circuit has to be checked on the complete circuit : the resistance between any conductive point and the grounding conductor shall not exceed more than 100mΩ.</p> <p>To prevent any accidental contact with live components, it is necessary to check that cables are not damaged, stripped or not in contact with a rotating part of the machine. The work place must be clean, dry.</p> <p>General recommendations :</p> <ul style="list-style-type: none"> - Check the wiring circuit - Lock the electrical cabinets - Use standardized equipment
	<p>Mechanical hazard Servomotors can accelerate in milliseconds. Running the motor can lead to other sections of the machine moving dangerously. Moving parts must be screened off to prevent operators coming into contact with them. The working procedure must allow the operator to keep well clear of the danger area.</p>
	<p>Burning Hazard Always bear in mind that some parts of the surface of the motor can reach temperatures exceeding 100°C.</p>

2. PRODUCT DESCRIPTION

2.1. Quick URL

All informations and datas are available on :

<http://www.parker.com/eme/skw>

2.2. Overview

The SKW frameless servomotor are the active parts of a servo motor: a rotor and a stator. The SKW series can not be used alone and must integrated into a complete system to provide a complete servomotor. The design, the construction, the certification and the tests are the responsibility of the integrator.

SKW series is the compact high-speed motor in kit version from PARKER. SKW are innovating solutions through direct drive, specifically conceived for industrial applications where high speed and high dynamic are needed.

The SKW motors are synchronous AC brushless motors with permanent magnets. The robustness due to a specific design and process is improved by dedicated features such as a Kevlar sleeve on the magnet and a potting with epoxy resin around the coils.

2.3. Motor description and Applications

The SKW motors are delivered as individual components: a rotor and a stator with housing allowing the water cooling

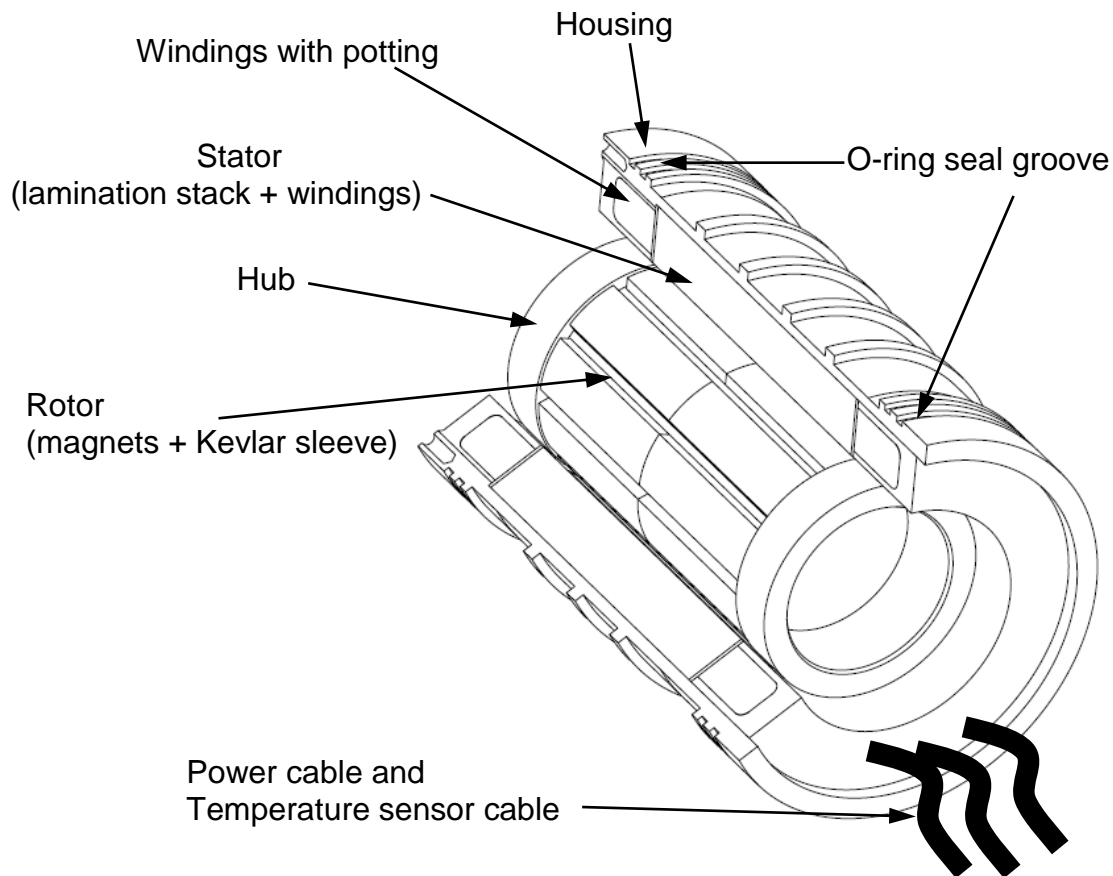

These components are typically assembled according to Figure 1 to make a complete motor spindle unit. The stator is water cooled to allow a higher torque density and a lower stator temperature rise. The motor is designed to have a large shaft diameter to increase the mechanical rigidity.

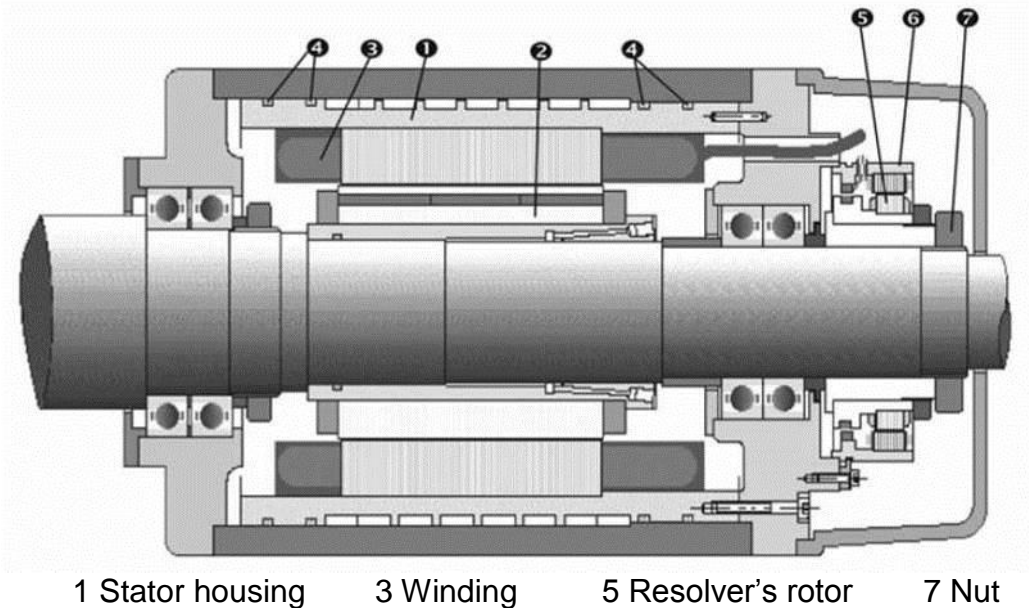

1 Stator housing	3 Winding	5 Resolver's rotor	7 Nut
2 Rotor	4 O-Ring	6 Resolver's stator	

Figure 1 : Typical SKW motor assembly

The SKW motors have been successfully used in machine tool application and specially in multi spindle lathe in place of the traditional induction motor, gears and levers.

For the end user, the main improvements provided by the SKW motors are :

- the compactness essential for multi spindle lathe
- dedicated speed for each spindle for the best surface finishes, to reach the shortest cycle time and for a longer tool life time.
- better accuracy due to the low shaft thermal expansion (low heat generation in the rotor),
- lower noise due to the no gears and levers
- maintenance free due to the no gears and levers
- compatible with third party drive
- oil proof



2.4. General Technical Data

Motor type	Permanent-magnet synchronous motor										
Magnet material	Nd-Fe-B										
Number of poles	<table border="1"><tr><td>Size:</td><td>SKW073</td><td>SKW082</td><td>SKW091</td><td>SKW096</td></tr><tr><td>Nbr of poles:</td><td>10</td><td>10</td><td>10</td><td>10</td></tr></table>	Size:	SKW073	SKW082	SKW091	SKW096	Nbr of poles:	10	10	10	10
Size:	SKW073	SKW082	SKW091	SKW096							
Nbr of poles:	10	10	10	10							
Outer diameter without water housing	73 mm 82 mm 91 mm 96 mm										
Degree of protection	IP00										
Cooling	Water cooled										
Cooling water temperature	5°C to 25°C (IEC 60034-1) – to avoid condensation see §3.5										
Altitude	Up to 1000m (IEC 60034-1) (for higher altitude see “Altitude derating”)										
Rated voltage	400VAC and 480VAC										
Connections	Power cable, PTC probes and KTY84-130 sensor										
Insulation of the stator winding	Class F according to EN 60034-1 with potting										
Thermal protection	1 PTC probes and 1 KTY84-130 sensor										
Ambiant temperature	0...+40°C (IEC 60034-1) - to avoid condensation see §3.5										
Storage temperature	-20... +60°C										



2.5. Product Code

Code	S	K	W	0	8	2	_	0	5	0	L	A	P	R	3	0	0	0		
Product Series	_____		_____				_____		_____			_____			_____			_____		
Cooling Method	_____		_____				_____		_____			_____			_____			_____		
W = Water cooling																				
Stator external diameter without water jacket	_____		_____				_____		_____			_____			_____			_____		
073 = 73 mm																				
082 = 82 mm																				
091 = 91 mm																				
096 = 96 mm																				
Type	_____																			
_ : Motor																				
S : Stator																				
R : Rotor																				
Active Part Length	_____		_____				_____		_____			_____			_____			_____		
Torque / Speed characteristics	_____		_____				_____		_____			_____			_____			_____		
See motor datas																				
Unused character	_____																			
Mechanical Option	_____																			
2 : without water jacket, with hub (only on request)																				
3 : with water jacket, with hub																				
000 : Standard motor	_____																			

3. TECHNICAL DATAS

3.1. Motor selection

3.1.1. Altitude derating

From 0 to 1000 m : no derating

From 1000 to 4000 m : torque derating of 5% for each step of 1000 m

3.1.2. Temperature derating

3.1.2.1. Water cooled motor

Typical values are given with a water inlet temperature of 25°C and a temperature gradient Inlet-Outlet of 10°C. These references lead to a winding overheating of **90°C** corresponding to a winding temperature of **115°C**. Recommendations regarding condensation issues are given at § 3.5

It is possible to increase a little bit the Inlet temperature up to 40°C, but the torque must be reduced. The following formula gives an indicative about the torque derating at low speed. But in any case refer to PARKER technical department to know the exact values

At low speed the torque derating is given by the following formula for an water Inlet temperature > 25°C.

$$Torque_derating[\%] = 100 * \sqrt{\frac{(115^{\circ}C - Inlet_temperature^{\circ}C)}{90^{\circ}C}}$$



At high speed, the calculation is more complex, and the derating is much more important. Please refer to PARKER to know the precise data of Torque derating according to water inlet temperature at high speed for a specific motor.

3.1.3. Thermal equivalent torque (rms torque)

The selection of the right motor can be made through the calculation of the rms torque M_{rms} (i.e. root mean squared torque) (sometimes called equivalent torque).

This calculation does not take into account the thermal time constant. It can be used only if the overload time is much shorter than the copper thermal time constant.

The rms torque M_{rms} reflects the heating of the motor during its duty cycle.

Let us consider:

- the period of the cycle T [s],
- the successively samples of movements i characterized each ones by the maximal torque M_i [Nm] reached during the duration Δt_i [s].

So, the rms torque M_{rms} can be calculated through the following basic formula:

$$M_{rms} = \sqrt{\frac{1}{T} * \sum_{i=1}^n M_i^2 \Delta t_i}$$

Example:

For a cycle of 2s at 0 Nm and 2s at 100Nm, the rms torque is

$$M_{rms} = \sqrt{\frac{1}{4} * 100^2 * 2} = 70,7Nm$$

Illustration :

Acceleration-deceleration torque:	500 Nm for 2 s.
Resistant torque:	100 Nm during all the movement.
Max-min speed:	± 1000 rpm during 2 s.
Max torque provided by the motor:	600 Nm.
rms torque:	387 Nm.

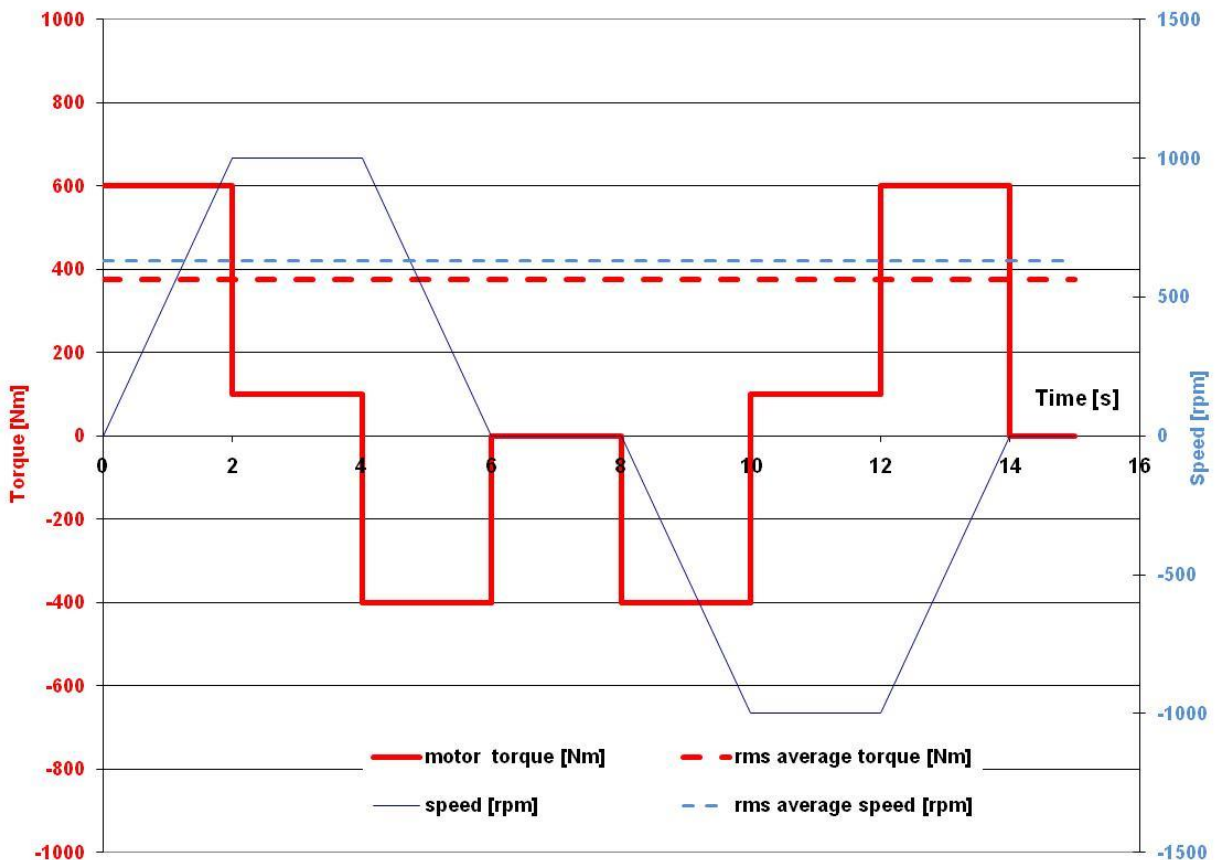

The maximal torque M_i delivered by the motor at each segment i of movement is obtained by the algebraic sum of the acceleration-deceleration torque and the resistant torque. Therefore, M_{max} corresponds to the maximal value of M_i .

Selection of the motor :

The motor adapted to the duty cycle has to provide the rms torque M_{rms} at the rms speed(*) without extra heating. This means that the permanent torque M_n available at the average speed presents a sufficient margin regarding the rms torque M_{rms} .

$$\Omega_{rms} = \sqrt{\frac{1}{T} * \sum_{i=1}^n \Omega_i^2 \Delta t_i}$$

(*) rms speed is calculated thanks to the same formula as that used for the rms torque. The mean speed cannot be used (in general mean speed is equal to zero). Only use the rms speed

Furthermore, each M_i and speed associated Ω_i of the duty cycle has to be located in the operational area of the torque vs speed curve

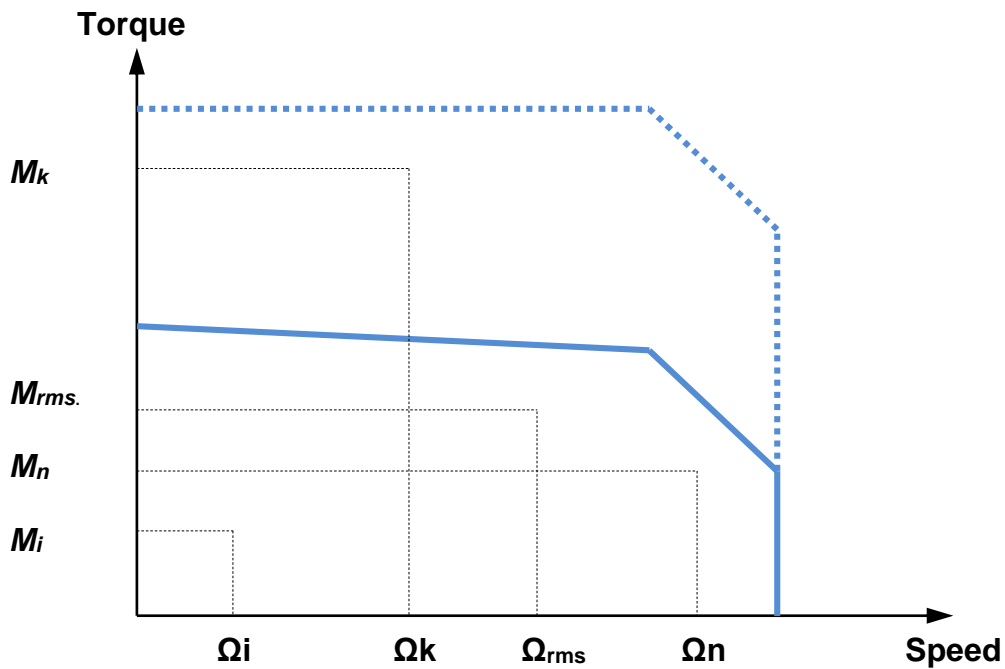



3.1.4. Drive selection

The drive selection depends on its rated power, nominal current and maximal electrical frequency able to be managed by the drive.

	Please refer to the drive technical documentation for any further information and to select the best motor and drive association.
---	---

	Due to the maximum electrical frequency able to be managed by the drive, the motor has a speed limitation given as follows: $\text{Speed limitation (rpm)} = \frac{2 * \text{Max_drive_frequency (Hz)} * 60}{\text{Number_of_poles}}$
---	--

	Other limitations can come from mechanical integration like the bearing type (steel straight, hybrid or Xlife) or seal...
---	---

	SKW range is not compatible with the flux weakening mode
--	--

3.1.5. Current limitation at stall conditions (i.e. speed < 3 rpm)

Recommended reduced current at speed < 3 rpm:

$$I_{reduced} = \frac{1}{\sqrt{2}} * I_0 \cong 0.8 * I_0$$

	<p>Warning: The current must be limited to the prescribed values. If the nominal torque has to be maintained at stop or low speed (< 3 rpm), imperatively limit the current to 80% of I₀ (permanent current at low speed), in order to avoid an excessive overheating of the motor.</p>
--	---

	<p>Please refer to the drive technical documentation for any further information and to choose functions to program the drive.</p>
--	--

3.1.6. Peak current limitations

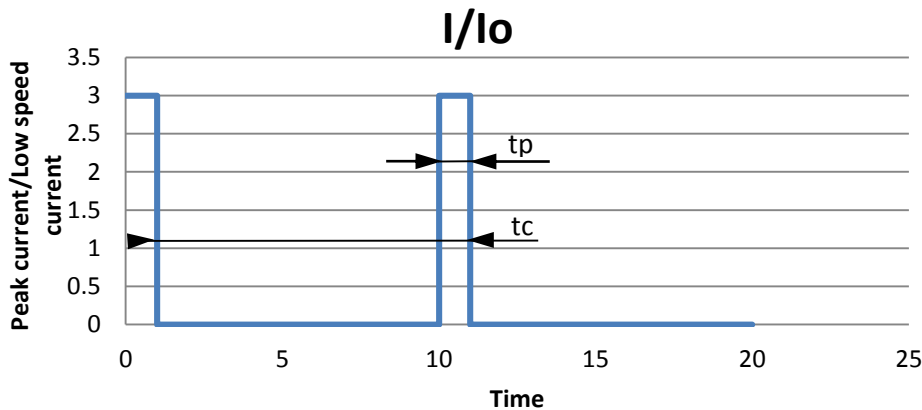

It is possible to use the SKW motors with a current higher than the permanent current. But, to avoid any overheating, the following rules must be respected.

- 1) The peak currents and peak torques given in the data sheet must never be exceeded
- 2) The thermal equivalent torque must be respected (§3.1.3)
- 3) If 1) and 2) are respected (it can limit the peak current value or duration), the peak current duration (tp) must be limited, in addition, accordingly to the following table (I₀ is the permanent current at low speed):

I _{peak} /I _n	T _p (second)							
	1.2	1.4	1.6	1.8	2	2.2	2.4	>2.4
SKW073	4.0	2.0	1.15	0.85	0.60	0.47	0.37	<0.2
SKW082	5.3	2.4	1.46	1.01	0.75	0.58	0.48	<0.2
SKW091	8.0	4.0	2.30	1.60	1.17	0.90	0.70	<0.3
SKW096	5.6	2.5	1.45	1.05	0.79	0.61	0.50	<0.2

The peak current duration is calculated for a temperature rise of 3°C
Consult us for more demanding applications.

3.2. SKW Characteristics: Torque, speed, current, power...

The torque vs speed graph below explains different intrinsic values of the next tables.

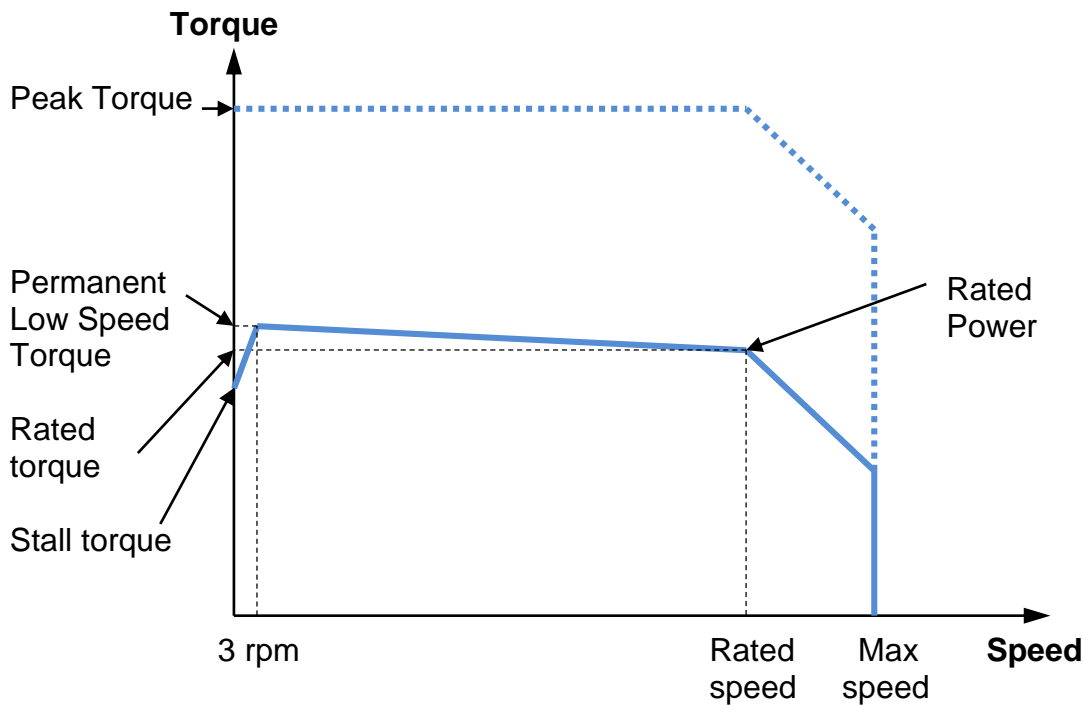

3.2.1. SKW data with water cooling – Mains voltage 400V

Motor	Rated Power P _n [kW]	Rated Torque M _n [Nm]	Rated Current I _n [Arms]	Rated Speed N _n [rpm]	Low speed torque M _o [Nm]	Low speed Current I _o [Arms]	Peak Torque M _{peak} [Nm]	Peak Current I _{peak} [Arms]	Max. Speed N _{max} [rpm]	Frequency at max speed [Hz]
400 VAC power supply - three-phased										
SKW073-050-LAM	3,1	4,0	10,4	7470	4,0	10,2	8,3	20,0	12000	1000
SKW073-100-LAM	6,3	8,8	21,1	6810	10,0	23,2	17,8	40,0	12000	1000
SKW073-150-LAM	9,7	13,5	27,3	6820	15,4	30,4	28,4	53,8	11000	917
SKW073-200-LAM	13,0	19,3	40,9	6450	21,8	45,2	37,8	75,8	11000	917
SKW082-046-LAM	5,1	4,0	10,2	12000	4,4	10,7	8,6	20,0	12000	1000
SKW082-092-LAM	10,7	9,3	21,6	11000	10,1	22,8	23,0	48,6	11000	917
SKW082-138-LAM	15,3	14,6	30,6	10000	15,8	32,3	31,0	60,0	10000	833
SKW082-184-LAM	21,2	20,3	44,7	10000	22,2	47,7	44,2	90,0	10000	833
SKW091-046-LAM	6,9	5,5	14,3	12000	6,5	16,3	10,7	28,2	12000	1000
SKW091-092-LAM	15,4	12,2	29,4	12000	15,1	35,4	23,0	55,6	12000	1000
SKW091-138-LAM	20,8	19,9	40,1	10000	23,8	47,1	36,1	73,3	10000	833
SKW091-184-LAM	28,0	26,8	56,8	10000	31,9	66,4	48,1	103,4	10000	833
SKW096-046-LAM	3,6	6,9	12,9	5010	7,1	13,1	13,7	26,0	10000	833
SKW096-092-LAM	7,8	16,3	28,1	4570	16,8	28,7	33,8	60,0	10000	833
SKW096-138-LAM	11,7	26,4	41,4	4240	27,4	42,4	54,3	87,9	9000	750
SKW096-184-LAM	16,2	36,0	59,6	4300	37,4	61,2	70,6	120,0	9000	750



3.2.2. Further Data

Motor	Ke [Vrms/krpm]	Kt (sine) [Nm/Arms]	Winding Resistance [ohms]	Inductance [mH]	Moment of Inertia J [kgmm ²]	Water Flow [l/min]
SKW073-050-LAM	30,0	0,394	1,93	2,18	170	1
SKW073-100-LAM	30,0	0,429	0,72	0,93	280	1
SKW073-150-LAM	34,6	0,508	0,58	0,78	390	1
SKW073-200-LAM	32,3	0,482	0,34	0,49	500	1
SKW082-046-LAM	32,2	0,408	1,88	2,36	370	1
SKW082-092-LAM	32,2	0,444	0,70	1,00	670	2
SKW082-138-LAM	34,5	0,490	0,49	0,72	970	3
SKW082-184-LAM	32,2	0,465	0,29	0,46	1300	4
SKW091-046-LAM	29,3	0,396	0,78	2,41	370	2
SKW091-092-LAM	29,3	0,428	0,29	1,06	670	4
SKW091-138-LAM	33,8	0,506	0,23	0,91	970	6
SKW091-184-LAM	31,6	0,481	0,14	0,58	1300	8
SKW096-046-LAM	39,8	0,540	1,45	2,53	1000	2
SKW096-092-LAM	39,8	0,586	0,51	1,03	1800	4
SKW096-138-LAM	42,6	0,646	0,33	0,73	2500	6
SKW096-184-LAM	39,8	0,611	0,20	0,46	3300	8

3.2.3. Time constants of the motor

3.2.3.1. Electric time constant:

$$\tau_{elec} = \frac{L_{ph_ph}}{R_{ph_ph}}$$

With following values given in the motor data sheet
L_{ph_ph} inductance of the motor phase to phase [H],
R_{ph_ph} resistance of the motor phase to phase at 25°C [Ohm].

Example:

Motor series SKW082_092LAM

L_{ph_ph} = 1 mH or 1E-3 H

R_{ph_ph} at 25°C = 0.697 Ohm

→ $\tau_{elec} = 1E-3/0.697 = 1.43 \text{ ms}$

An overall summary of motor time constants is given a little further.

3.2.3.2. Mechanical time constant:

$$\tau_{mech} = \frac{R_{ph_n} * J}{Kt * Ke_{ph_n}} = \frac{0.5 * R_{ph_ph} * J}{(3 * \frac{Ke_{ph_ph}}{\sqrt{3}}) * \frac{Ke_{ph_ph}}{\sqrt{3}}}$$

$$\tau_{mech} = \frac{0.5 * R_{ph_ph} * J}{(Ke_{ph_ph})^2}$$

With following values obtained from the motor data sheet:

R_{ph_ph} resistance of the motor phase to phase at 25°C [Ohm],

J inertia of the rotor [kgm²],

Ke_{ph_ph} back emf phase coefficient phase to phase [V_{rms}/rad/s].

The coefficient **Ke_{ph_ph}** in the formula above is given in [V_{rms}/rad/s]

To calculate this coefficient from the datasheet, use the following relation:

$$Ke_{ph_ph[V_{rms}/rad/s]} = \frac{Ke_{ph_ph[V_{rms}/1000rpm]}}{\frac{2 * \pi * 1000}{60}}$$

Example:

Motor series SKW082_092LAM

R_{ph_ph} at 25°C = 0.697 Ohm

J = 0.00067 kgm²

Ke_{ph_ph} [V_{rms}/1000rpm] = 32.2 [V_{rms}/1000rpm]

→ **Ke_{ph_ph}** [V_{rms}/rad/s] = 32.2/(2*π*1000/60) = 0.3075 [V_{rms}/rad/s]

→ $\tau_{mech} = 0.5 * 0.697 * 0.00067 / (0.3075^2) = 2.47 \text{ ms}$

Remarks:

For a DC motor, the mechanical time constant σ_{mech} represents the duration needed to reach 63% of the final speed when applying a voltage step without any resistant torque, if the electrical time constant is much smaller than the mechanical time constant.

An overall summary of motor time constants is given a little further.

3.2.3.3. Thermal time constant of the copper:

$$\tau_{\text{therm}} = Rth_{\text{copper_iron}} * Cth_{\text{copper}}$$

$$Cth_{\text{copper}[J/^{\circ}K]} = Mass_{\text{copper}[Kg]} * 389_{[J/kg^{\circ}K]}$$

With:

$Rth_{\text{copper_iron}}$ thermal resistance between copper and iron [$^{\circ}K/W$]

Cth_{copper} thermal capacity of the copper [$J/^{\circ}K$]

$Mass_{\text{copper}}$ mass of the copper (winding) [kg]

Hereunder is given an overall summary of motor time constants:

Type	Electric time constant [ms]	Mechanical time constant [ms]	Thermal time constant of copper [s]
SKW073-050-LAM	1,13	1,995	12,5
SKW073-100-LAM	1,293	1,226	10,7
SKW073-150-LAM	1,341	1,038	9,7
SKW073-200-LAM	1,433	0,903	9,6
SKW082-046-LAM	1,255	3,686	15,6
SKW082-092-LAM	1,435	2,468	13,5
SKW082-138-LAM	1,48	2,174	12,2
SKW082-184-LAM	1,585	1,973	12,2
SKW091-046-LAM	3,098	1,839	24,7
SKW091-092-LAM	3,681	1,232	21,0
SKW091-138-LAM	3,974	1,065	19,2
SKW091-184-LAM	4,021	1,024	17,9
SKW096-046-LAM	1,745	5,026	20,3
SKW096-092-LAM	2,008	3,199	16,7
SKW096-138-LAM	2,204	2,487	15,7
SKW096-184-LAM	2,23	2,325	14,5

3.2.4. Voltage withstand characteristics of SKW series

The motors fed by converters are subject to higher stresses than in case of sinusoidal power supply. The combination of fast switching inverters with cables will cause over voltage due to the transmission line effects. The peak voltage is determined by the voltage supply, the length of the cables and the voltage rise time. As an example, with a rise time of 200 ns and a 30 m (100 ft) cable, the voltage at the motor terminals is twice the inverter voltage.

The insulation system of the SKW motors is designed to withstand high repetitive pulse voltages and largely exceeds the recommendations of the IEC/TS 60034-25 ed 2.0 2007-03-12 for motors without filters up to 480V AC.

Higher supply voltages are available on request.

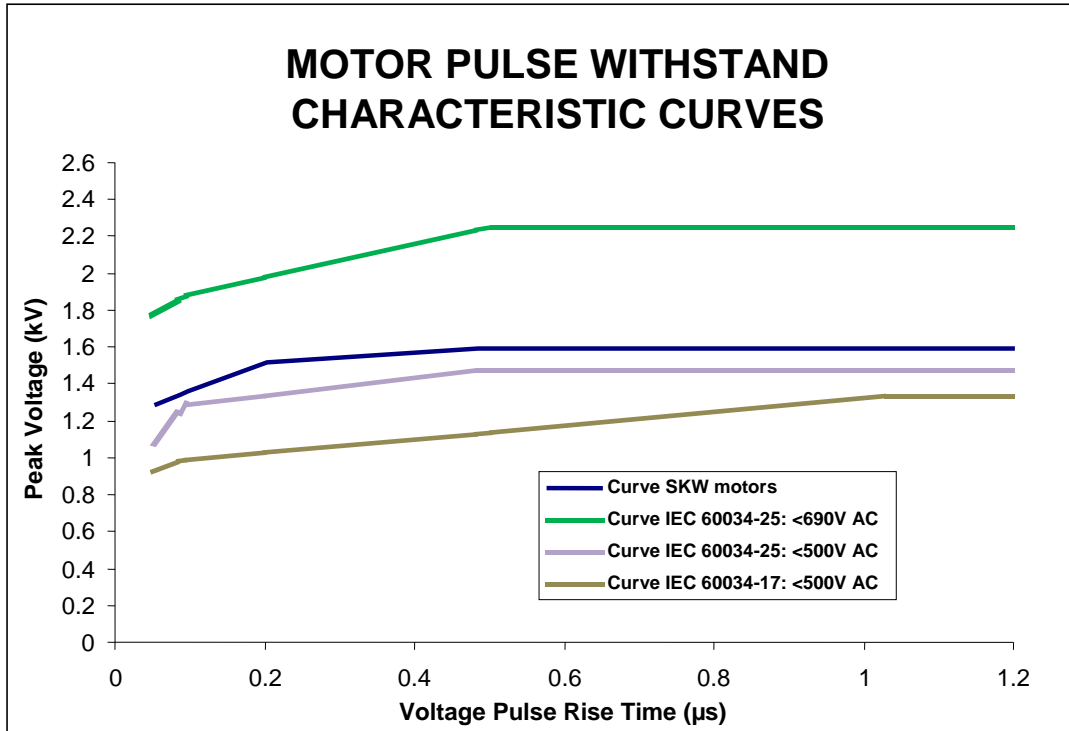

Figure 1: Minimum Voltage withstands characteristics for motors insulations according to IEC standards. At the top are the typical capabilities for the SKW motors with additional insulation.

Note: The pulse rise times are defined in accordance with the IEC/TS 60034-17 ed4.0 2006-05-09.

The SKW motors can be used with a supply voltage up to 480 V under the following conditions:

- The pulse rise times must be longer than 50 ns.
- The repetitive pulse voltages must not exceed the values given in figure 1, Curve IEC 60034-25 : <500V AC.

3.3.2. SKW082****R3000

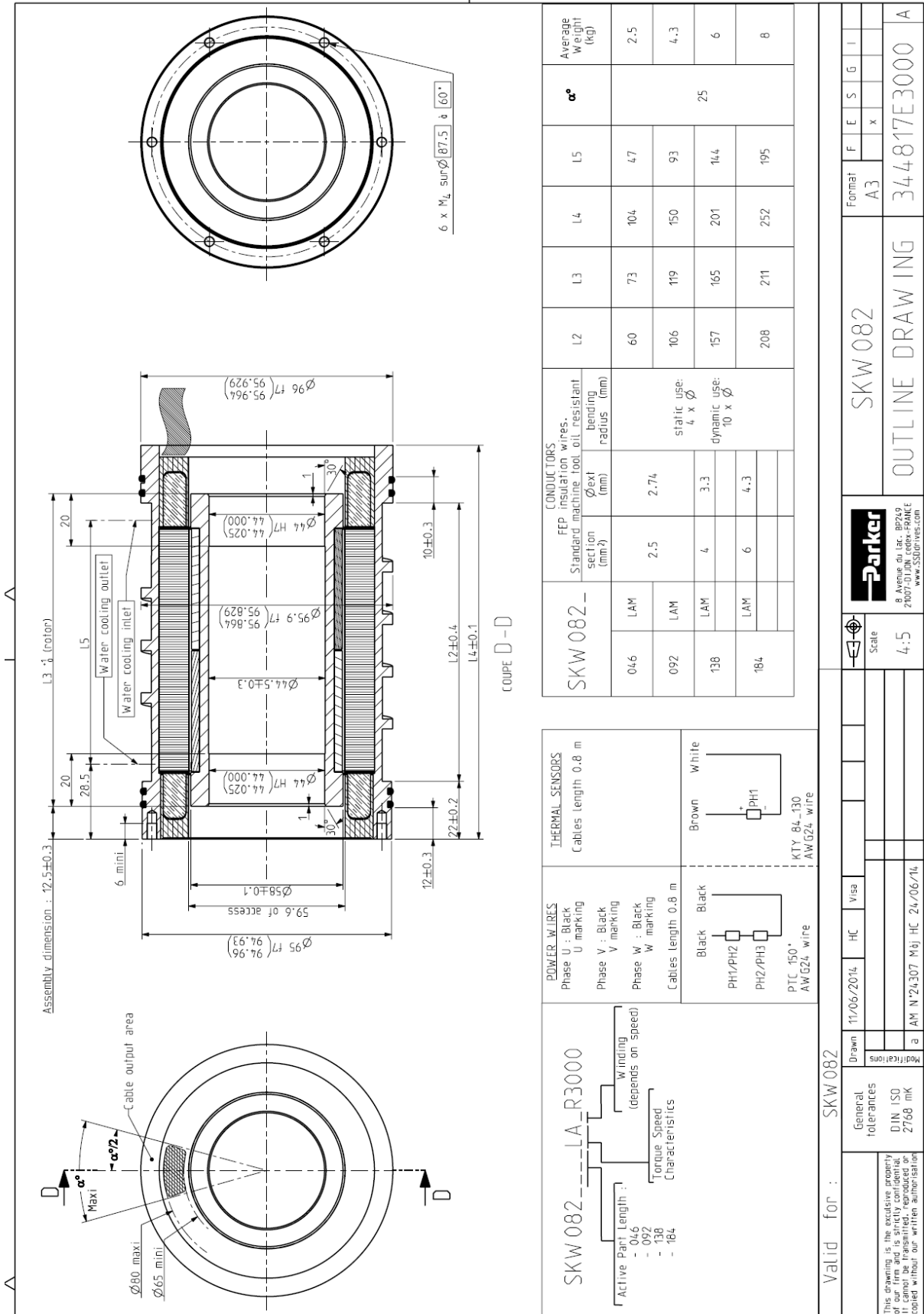

Valid for : SKW082

 8 Avenue du lac - BP249 27007-DUN-CEDEX-FRANCE www.parker-france.com		SKW082	Format A3	F	E	S	G	I
Scale 4:5		OUTLINE DRAWING	344817E3000 A					
Drawn 11/06/2014 HC Visa Modifications a AM N°24307 Mbj HC 24/06/14		This drawing is the exclusive property of our firm and is strictly confidential. It is not to be copied without our written authorisation.						

3.4. Motor mounting recommendations

	<p><u>Warning</u> : The recommendations in this chapter are general. It is the integrator responsibility to check if it complies with his application and to chose and define the correct way to integrate the kit according to his application, all the regulations and standards applicable.</p>
---	--

3.4.1. Frame recommendation

	<p><u>Warning</u> : The user has the entire responsibility to design and prepare the housing, the shaft, connection box, the support, the coupling device, shaft line alignment, and shaft line balancing.</p>
---	--

Machine design must be even, sufficiently rigid, precise and shall be dimensioned as to avoid vibrations due to resonance. Integrator bears the entire responsibility for choice of the key components, such as bearing, encoder, electric connection and mechanical parts design.

	<p><u>Warning</u> : A motor well-balanced in itself and of a grade A conforming with IEC 60034-14, may exhibit large vibrations when installed in-situ arising from various causes, such as unsuitable foundations, reaction of the driven motor, current ripple from the power supply, etc. Vibration may also be caused by driving elements with a natural oscillation frequency very close to the excitation due to the small residual unbalance of the rotating masses of the motor. In such cases, checks should be carried out not only on the machine, but also on each element of the installation. (See ISO 10816-3).</p>
---	--

	<p><u>Warning</u> : A bad setting of the electronic control of the close loop (gain too high, incorrect filtering ...) can occur an instability of the shaft line, vibration or/and breakdown - . Please consult us</p>
---	---

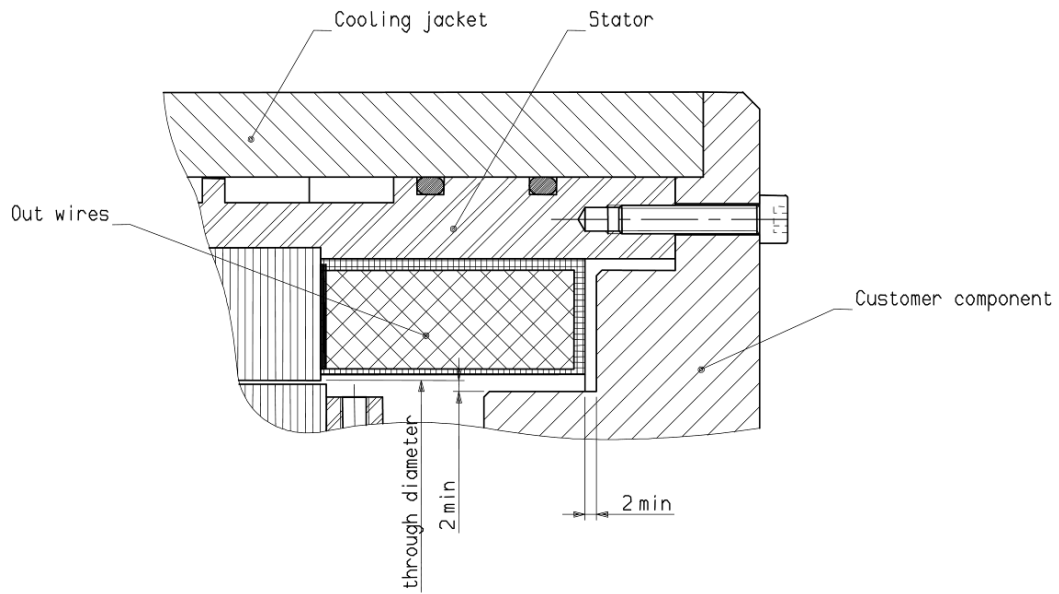

3.4.2. Motor flanges

Let 2mm mini between windings and metallic part like flanges.



3.4.5. O-ring Specification

For SKW with water jacket (R3000), the cooling circuit is sealed by four O-rings seal between stator and user's housing.

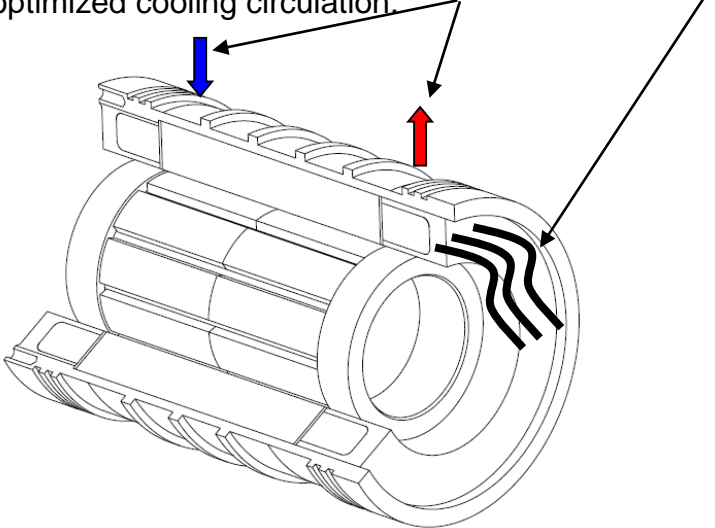
	<p>Caution: The 4 O-rings must be greased with an ordinary lubricant before mounting to avoid damages and leakages.</p>
	<p>Caution: Be careful not to make damage on the O-ring during the mounting to avoid leakage. It's recommended to realize a waterproof test with 5 bars air pressure during 30 minutes and check if there is not pressure decreasing.</p>
	<p>Caution: Water inlet and outlet must be aligned with the cables inlet to guarantee an optimized cooling circulation.</p> 

Motor	O-ring diameter (mm)	Cross section (mm)	Material	Hardness	Working temperature (°C)	Parker part number
SKW073	75.92	1.78	FKM	70 shores	-20/+200°C	5340P0109
SKW082	88.62	1.78	FKM	70 shores	-20/+200°C	5340P0121
SKW091	94.97	1.78	FKM	70 shores	-20/+200°C	5340P0081
SKW096	101.32	1.78	FKM	80 shores	-20/+200°C	5340P0122

3.4.6. Condensation water drain hole

Condensation and risk of rust may occur when the temperature gradient between the air and the water becomes significant, so drain holes must be integrated on the frame design. These holes must be positioned at the lowest point in the motor housing. Condensation water drain holes must be checked at least once a year

3.4.7. Design Compliance

The integrator is responsible for compliance with directives, regulations and standards. Nonexhaustively, the integrator has to certify the complete motor design in order to be conformed to the guide lines (nonexhaustively).

- Low Voltage Directive 2014/35/EU
- RoHs Directive 2011/65/CE
- EMC Directive 2004/108/CE

The complete motor must comply with the IEC60034 standard

The heating of the complete motor must meet the requirements of the class F insulation (cf. IEC 60034-1)

3.4.8. Dielectric test

Each complete motor must undergo once completely, a dielectric test (Routine test) in accordance with the standard IEC 60034-1 (i.e. 1500 V during 1 min for 230 Vac).

3.4.9. Earthing

A protective earth cable with the appropriate cable diameter must connect the complete motor stator to the grounding (cf. standards: NF C15-100, CEI 60364-1, IEC 60204-1).

Section of phases conductors, S [mm ²]	Corresponding minimal cross-section of earthing conductor, S_p [mm ²]
$S \leq 16$	S
$16 < S \leq 35$	16
$S > 35$	$0.5S$

3.4.10. Minimum clearances for insulation and creepage distances

Depending on the pollution degree and the voltage in use, the minimum clearances for insulation and creepage distances must meet the standard EN 60664-1.

It is the integrator's responsibility to take the needed actions to comply with these distances or by adding proper additional insulation.

For information:

- *Pollution degree 1.* No pollution or only dry, nonconductive pollution occurs. The pollution has no influence (example: sealed or potted products).
- *Pollution degree 2.* Normally only nonconductive pollution occurs. Occasionally a temporary conductivity caused by condensation must be expected (example: product used in typical office environment).
- *Pollution degree 3.* Conductive pollution occurs, or dry, nonconductive pollution occurs that becomes conductive due to expected condensation (example: products used in heavy industrial environments that are typically exposed to pollution such as dust).
- *Pollution degree 4.* Pollution generates persistent conductivity caused, for instance, by conductive dust or by rain or snow.



Minimum clearances for insulation:

Voltage rms	Required impulse withstand voltage V	Minimum clearances in air in millimeters up to 2000 m above sea level							
		Case A (inhomogeneous field)				Case B (homogeneous field)			
		Pollution degree				Pollution degree			
		1 mm	2 mm	3 mm	4 mm	1 mm	2 mm	3 mm	4 mm
50V	600	0,06	0,2	0,8	1,6	0,06	0,2	0,8	1,6
from 100V to 250V	1500	0,5	0,5	0,8	1,6	0,3	0,3	0,8	1,6
up to 500V	2000	1	1	1	1,6	0,45	0,45	8	1,6

N.B. Please refer to the standard EN 60664-1 for more information.

Minimum creepage distances for equipment subject to long-term stresses

Voltage rms	Creepage distances in millimeters									
	Pollution degree									
	1	2 Material group			3 Material group			4 Material group		
	mm	I mm	II mm	III mm	I mm	II mm	III mm	I mm	II mm	III mm
50	0,18	0,6	0,85	1,2	1,5	1,7	1,9	2	2,5	3,2
100	0,25	0,71	1	1,4	1,8	2	2,2	2,4	3	3,8
160	0,32	0,8	1,1	1,6	2	2,2	2,5	3,2	4	5
200	0,42	1	1,4	2	2,5	2,8	3,2	4	5	6,3
250	0,56	1,25	1,8	2,5	3,2	3,6	4	5	6,3	8
320	0,75	1,6	2,2	3,2	4	4,5	5	6,3	8	10
400	1	2	2,8	4	5	5,6	6,3	8	10	12,5
500	1,3	2,5	3,6	5	6,3	7	8	10	12,5	16

N.B. Please refer to the standard EN 60664-1 for more information.

3.4.1. Ground continuity compliance

3.4.2. Ground continuity compliance

The complete motors must meet the standards IEC 60204-1.

Continuity of the grounding circuit : On each complete unit, the resistance between any conductive point and the grounding conductor shall not exceed than 100 mΩ. This test shall be performed before the dielectric tests. (EN 60204-1: Safety of the machine)

3.4.3. Protection rating

cf. IEC 60529 and IEC 60034-5

The frameless motors show an IP00 protection rating. It is the integrator's responsibility to ensure the appropriate protection rating depending on the use of the complete motor (protection against electric shocks of persons, protection against dust, liquids, solid particles, ...)

3.4.4. Overspeed test

A qualification test at 20% above the rated speed during at least 1 min, must be carried out according to the standard IEC 60034-1.

3.4.5. EMC Directive

cf. guide lines 2004-108 CE and standard IEC 61800-3

It is the integrator's responsibility to ensure that the complete motor and drive in use comply with the EMC directive.







3.4.6. Other requirements

The previous list is not exhaustive and all the other requirements in the regulation standard and directives must be checked by the integrator.

3.5. Cooling

In compliance with the IEC 60034-1 standards:

3.5.1. Water cooled motor – SKW series

	<p><u>Caution</u> : For option R2000 (without water jacket), It's impossible to cool the stator directly on the stack of laminations. Customers must to put a water jacket on the stator with a thermal resistance lowest as possible</p>
	<p><u>Danger</u>: The cooling system has to be operational when the motor is running or energized.</p>
	<p><u>Danger</u>: The Inlet temperature and the water flow have to be monitored to avoid any exceeding temperature values.</p>
	<p><u>Caution</u>: When motor is not running, the cooling system has to be stopped 10 minutes after motor shut down.</p>
	<p><u>Caution</u>: Condensation and risk of rust may occur when the temperature gradient between the air and the water becomes significant. Condensation is also linked to hygrometry rate. To avoid any issue, we recommend: $T_{\text{water}} > T_{\text{air}} - 2^{\circ}\text{C}$. The motor can be used with an ambient temperature between 27°C to 40°C with a high water temperature but with derating. If inlet water temperature becomes higher than 25°C, derating factor must be applied according to §3.1.2 Temperature Derating</p>
	<p><u>Caution</u>: the ambient air temperature shall not exceed 40°C in the vicinity of the motor flange</p>
	<p><u>Danger</u>: If the water flow stops, the motor can be damaged or destroyed causing accidents.</p>

3.5.2. Additives for water as cooling media

Please refer to motor technical data for coolant flow rates.

The water inlet temperature must not exceed **25°C** without torque derating.
The water inlet temperature must not be below **5°C**.

The inner pressure of the cooling liquid must not exceed **5 bars**.

	<p><u>Caution:</u> To avoid the corrosion of the motor cooling system (aluminum or steel), the water must have anti-corrosion additive.</p>
--	---

The spindle servomotors are water cooled. Corrosion inhibitors must be added to the water to avoid the corrosion. The complete cooling system must be taken into account to choose the right additive, this includes: the different materials in the cooling circuit, the chiller manufacturer recommendations, the quality of the water...

The right additive solution is the responsibility of the user. Some additives like TYFOCOR or GLYSANTIN G48 correctly used have demonstrated their ability to prevent corrosion in a closed cooling circuit

For example: Glysantin G48 recommendations are :

- Water hardness: 0 to 20°dH (0 – 3.6 mmol/l)
- Chloride content: max. 100ppm
- Sulphate content: max. 100ppm

	<p><u>Caution:</u> The water quality is very important and must comply with supplier recommendations. The additive quantity and periodic replacement must respect the same supplier recommendations.</p>
--	--

	<p><u>Caution:</u> The additive choice must take into account the global cooling system (chiller or water exchanger recommendations...).</p>
--	--

	<p>Select carefully the materials of all the cooling system parts (chiller, exchanger, hoses, adapters and fittings) because the difference between material galvanic potential can make corrosion.</p>
--	---



3.5.3. Motor cooling circuit data

SKW servomotors are cooled by water. An anti-corrosion product must be mixed to the water. The main characteristics of cooling are given in the table below:

Motor	Average flow necessary for cooling (water : 75% minimum)	Maxi drop pressure @ nominal water flow	Motor power losses at max speed and continuous operation	Maximum inlet cooling temperature	Maximum outlet cooling temperature
	L/min	Bars	kW	°C	°C
SKW073-050-LAM	1	1	0,5	40	50
SKW073-100-LAM	1		0,8		
SKW073-150-LAM	1		1,1		
SKW073-200-LAM	1		1,4		
SKW082-046-LAM	1	1	0,6	40	50
SKW082-092-LAM	2		1,1		
SKW082-138-LAM	3		1,5		
SKW082-184-LAM	4		1,9		
SKW091-046-LAM	2	1	0,6	40	50
SKW091-092-LAM	4		1,2		
SKW091-138-LAM	6		1,5		
SKW091-184-LAM	8		2,0		
SKW096-046-LAM	2	1	0,5	40	50
SKW096-092-LAM	4		0,9		
SKW096-138-LAM	6		1,3		
SKW096-184-LAM	8		1,7		

3.5.4. Chiller selection

Chiller must be able to evacuate motor power loss (see table above).
 Chiller pump must provide water flow through motor and pipe pressure drop.
 Inlet temperature must be inferior to 25°C.

You can find various chillers solutions in Parker Hiross - <http://www.dh-hiross.com/>

3.5.5. Flow derating according to glycol concentration

	Glycol concentration [%]					
	0	10	20	30	40	50
5	5.1	5.3	5.6	5.9	6.2	
10	10.2	10.6	11.1	11.8	12.4	
15	15.3	15.9	16.7	17.6	18.7	
20	20.4	21.2	22.2	23.5	24.9	
25	25.5	26.5	27.8	29.4	31.1	
30	30.6	31.8	33.4	35.3	37.3	
35	35.7	37.1	38.9	41.1	43.6	
40	40.8	42.4	44.5	47.0	49.8	
45	45.9	47.7	50.0	52.9	56.0	
50	51.0	53.0	55.6	58.8	62.2	
55	56.1	58.3	61.2	64.7	68.4	
60	61.2	63.5	66.7	70.5	74.7	
65	66.4	68.8	72.3	76.4	80.9	
70	71.5	74.1	77.8	82.3	87.1	
75	76.6	79.4	83.4	88.2	93.3	
80	81.7	84.7	89.0	94.1	99.5	
85	86.8	90.0	94.5	99.9	105.8	
90	91.9	95.3	100.1	105.8	112.0	
95	97.0	100.6	105.6	111.7	118.2	
100	102.1	105.9	111.2	117.6	124.4	
110	112.3	116.5	122.3	129.3	136.9	
120	122.5	127.1	133.4	141.1	149.3	
130	132.7	137.7	144.6	152.8	161.8	
140	142.9	148.3	155.7	164.6	174.2	
150	153.1	158.9	166.8	176.3	186.6	
160	163.3	169.5	177.9	188.1	199.1	
170	173.5	180.1	189.0	199.9	211.5	
180	183.7	190.6	200.2	211.6	224.0	
190	194.0	201.2	211.3	223.4	236.4	
200	204.2	211.8	222.4	235.1	248.9	

Use of the table above - Example

If the motor needs **25 l/min** with **0%** glycol,

If application needs **20%** glycol, the water flow must be **26.5 l/min**,

If application needs **40%** glycol, the water flow must be **29.4 l/min**.



Main formulas

$$Flow_rate = \frac{Power_dissipation * 60}{\Delta\theta^\circ * C_p}$$

With: *Flow rate* [l/min]
Power_dissipation [W]
 $\Delta\theta^\circ$ Gradient inlet-outlet [°C]
C_p thermal specific capacity of the water as coolant [J/kg°K]
(**C_p** depends on the % glycol concentration please see below)

Thermal specific capacity C_p according to % glycol concentration and temperature

We have considered an average temperature of the coolant of 30°C.

Glycol concentration [%]	Average temperature of the water as coolant [°C]	Thermal specific capacity of the water C_p [J/kg°K]
0	30	4176
30	30	3755
40	30	3551
50	30	3354

3.5.6. Water cooling diagram



Recommendation: The use of a filter allows to reduce the presence of impurities or chips in the water circuit in order to prevent its obstruction.

We recommend 0.1mm filter.

This section shows typical water cooling diagram :

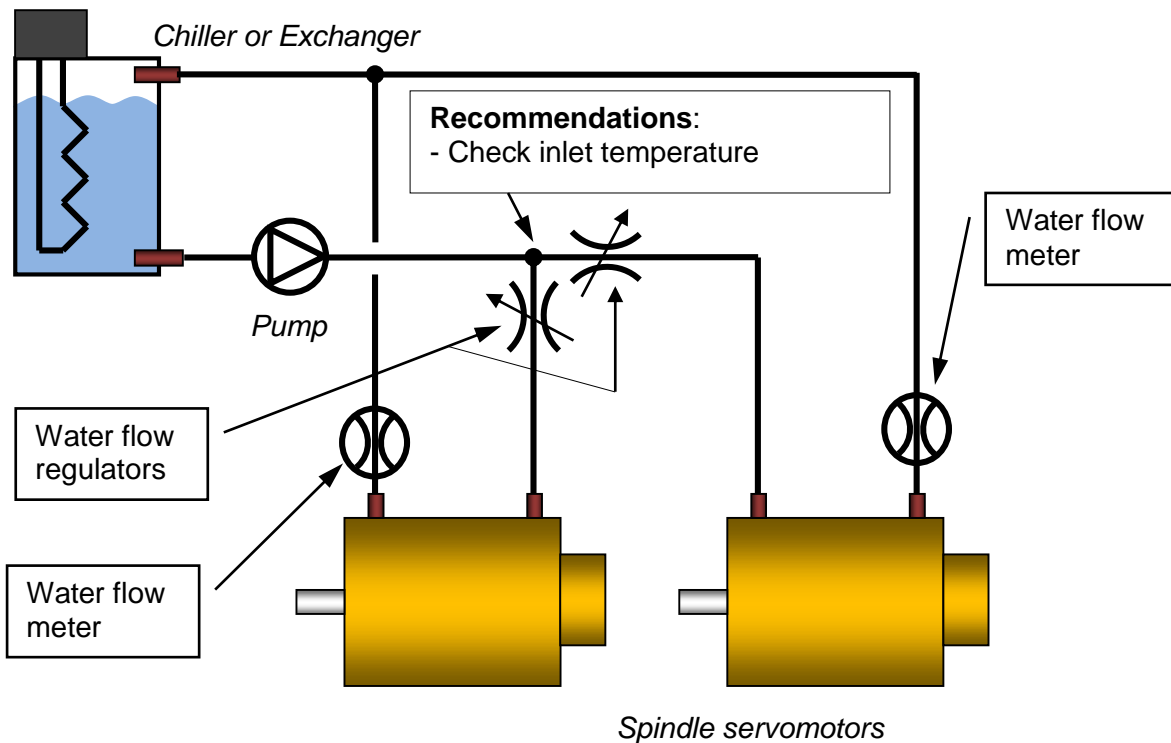
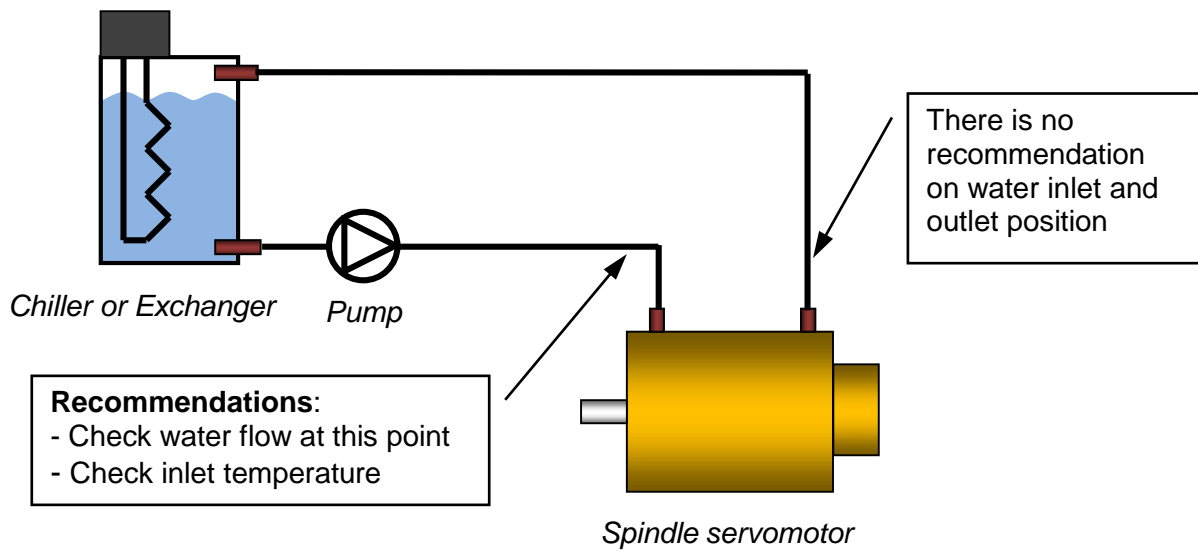

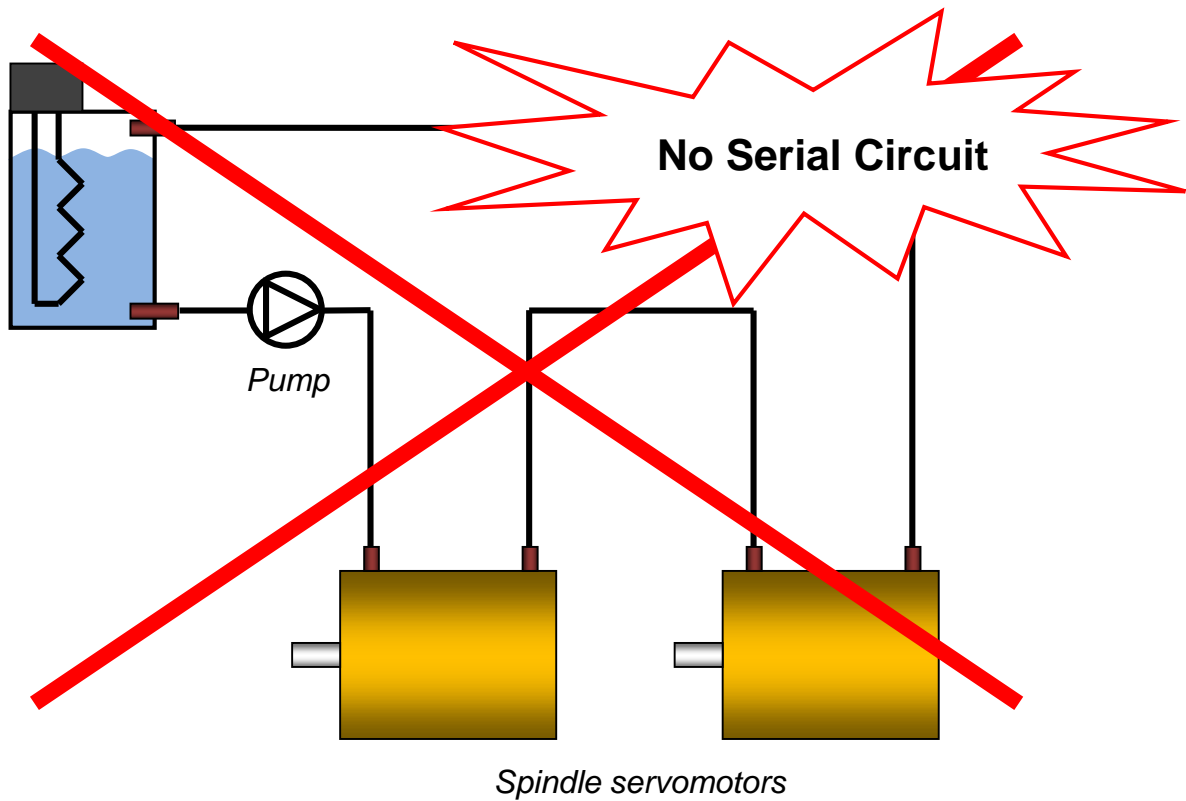
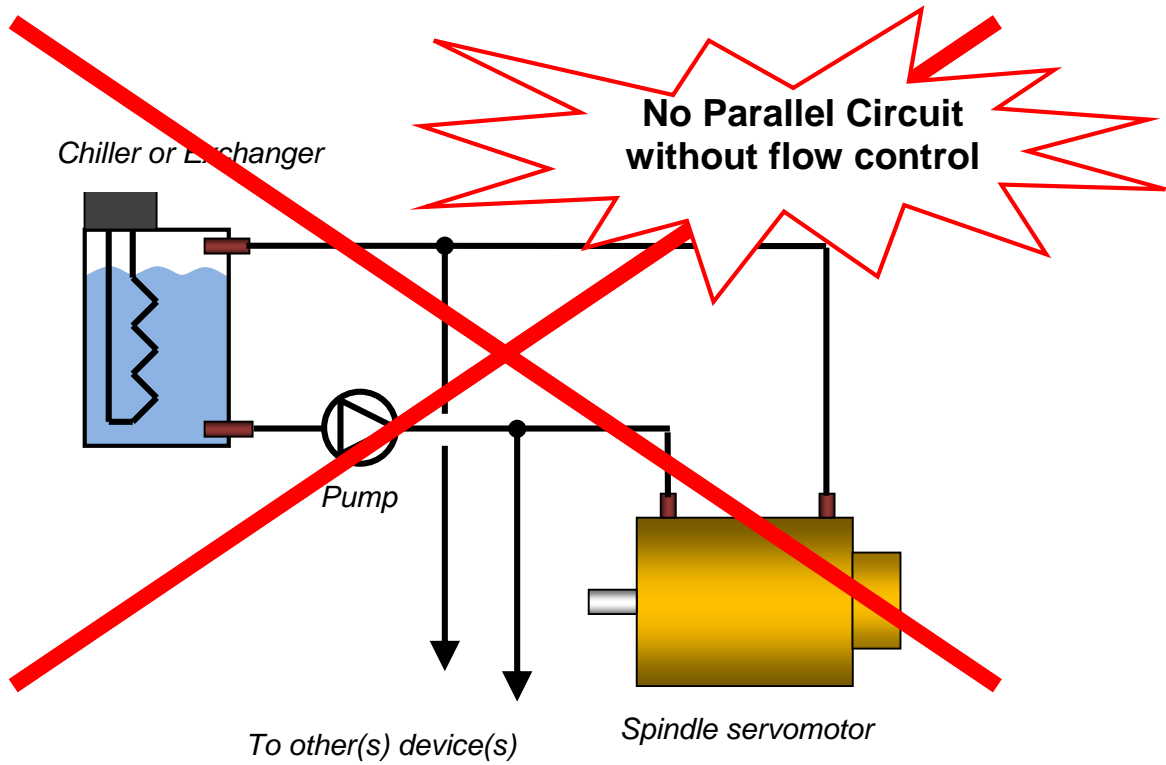

3.6. Thermal Protection

Protection against thermal overloading of the motor is provided by one PTC thermistors and one KTY temperature sensor (and one more in case of KTY failure) built into the stator winding as standard. The thermal sensors, due to their thermal inertia, are unable to follow very fast winding temperature variations. They achieve their thermal steady state after a few minutes.

Warning: To protect correctly the motor against very fast overload, please refer to 3.1.6. Peak current limitations

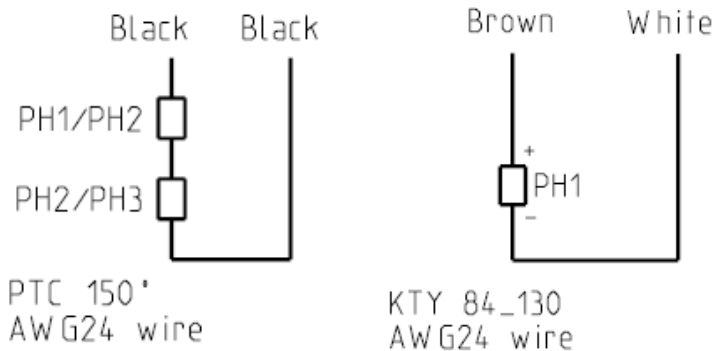

3.6.1. Alarm tripping with PTC thermistors :

The thermal probes (PTC thermistors) fitted in the servomotor winding trip the electronic system at $150^{\circ} \pm 5^{\circ} \text{C}$. When the rated tripping temperature is reached, the PTC thermistor resistance changes very quickly. This resistance can be monitored by the drive to protect the motor.

The graph and tab below shows PTC sensor resistance as a function of temperature (T_N is nominal temperature)

Temperature	Resistance value
-20°C up to $T_N - 20^{\circ}\text{C}$	$R \leq 500\Omega$
$T_N - 5^{\circ}\text{C}$	$R \leq 1100\Omega$
$T_N + 5^{\circ}\text{C}$	$R \geq 2660\Omega$
$T_N + 15^{\circ}\text{C}$	$R \geq 8000\Omega$

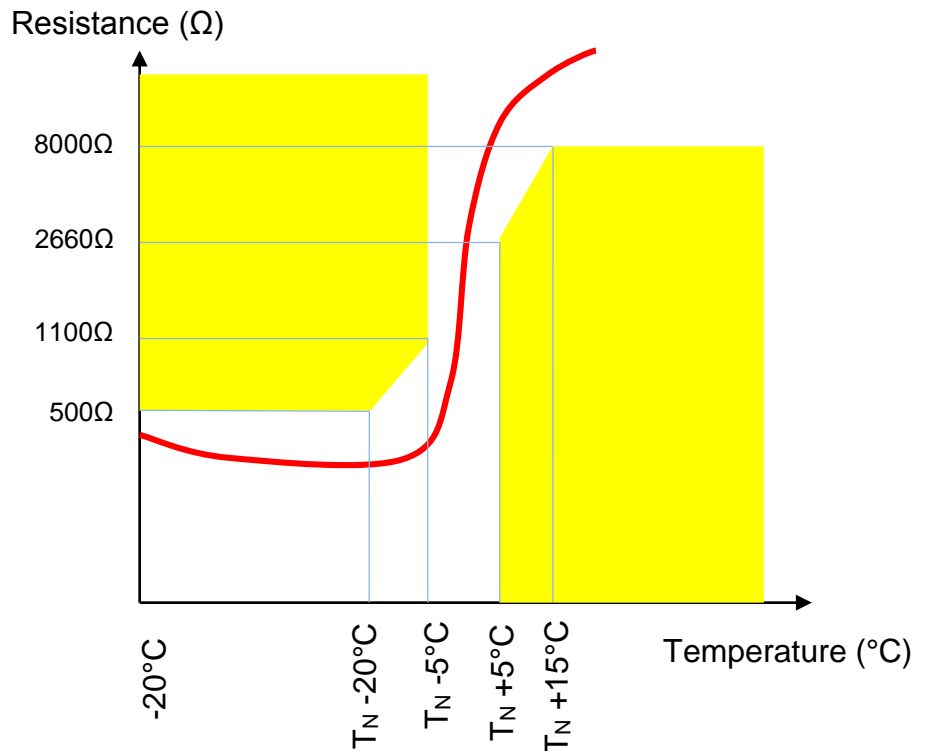

3.6.2. Temperature measurement with KTY sensors:

Motor temperature can also be continuously monitored by the drive using a KTY 84-130 thermal sensor built in to the stator winding. KTY sensors are semiconductor sensors that change their resistance according to an approximately linear characteristic. The required temperature limits for alarm and tripping can be set in the drive.

The graph below shows KTY sensor resistance vs temperature, for a measuring current of 2 mA:

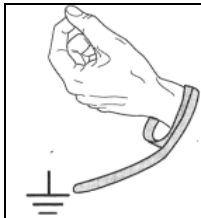
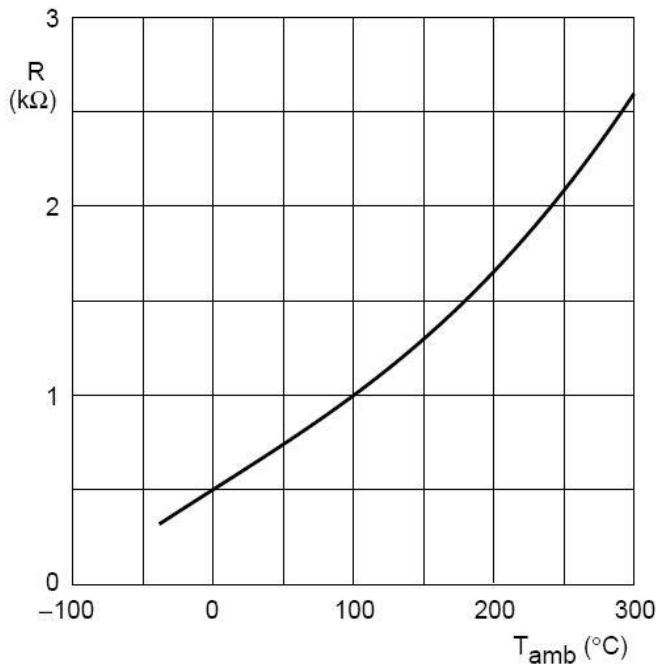

Warning: KTY sensor is sensitive to electrostatic discharge. So, always wear an antistatic wrist strap during KTY handling.



Warning: KTY sensor is polarized. Do not invert the wires.



Warning: KTY sensor is sensitive. Do not check it with a Ohmmeter or any measuring or testing device.



3.7.

3.8. Power electrical connections

3.8.1. Wires sizes

	<p>In every country, you must respect all the local electrical installation regulations.</p>
---	--

Not limiting example in France: NFC 15-100 or IEC 60364 as well in Europe.

	<p>Cable selection depends on the cable construction, so refer to the cable technical documentation to choose wire sizes</p>
	<p>Some drives have cable limitations or recommendations; please refer to the drive technical documentation for any further information.</p>

Cable selection

	<p>At standstill, the current must be limited at 80% of the low speed current I_0 and cable has to support peak current for a long period. So, if the motor works at standstill, the current to select wire size is $\sqrt{2} \times 0.8 I_0 \cong 1,13 \times I_0$.</p>
---	--

Sizes for H07 RN-F cable, for a 3 cores in a cable tray at 30°C max

Section [mm ²]	I_{max} [A _{rms}]
1.5	17
2.5	23
4	31
6	42
10	55
16	74
25	97
35	120
50	146
70	185
95	224
120	260
150	299
185	341
240	401
300	461



Example of sizes for H07 RN-F cable :

Conditions of use:

Case of 3 conductors type H07 RN-F: **60°C maximum**

Ambient temperature: 30°C

Cable runs on dedicated cables ways

Current limited to 80%*I₀ at low speed or at motor stall.

Example:

I₀=100 Arms

Permanent current at standstill : 80 Arms

Max permanent current in the cable = 113 Arms

Cable section selection = 35mm² for a 3 cores in a cable tray at 30°C max.

You also have to respect the Drive commissioning manual and the cables current densities or voltage specifications

3.8.2. Conversion Awg/kcmil/mm²:

Awg	kcmil	mm ²
	500	253
	400	203
	350	177
	300	152
	250	127
0000 (4/0)	212	107
000 (3/0)	168	85
00 (2/0)	133	67.4
0 (1/0)	106	53.5
1	83.7	42.4
2	66.4	33.6
3	52.6	26.7
4	41.7	21.2
5	33.1	16.8
6	26.3	13.3
7	20.8	10.5
8	16.5	8.37
9	13.1	6.63
10	10.4	5.26
11	8.23	4.17
12	6.53	3.31
14	4.10	2.08
16	2.58	1.31
18	1.62	0.82
20	1.03	0.52
22	0.63	0.32
24	0.39	0.20
26	0.26	0.13

3.8.3. Motor cable length

For motors windings which present low inductance values or low resistance values, the own cable inductance, respectively own resistance, in case of large cable length can greatly reduce the maximum speed of the motor. Please contact PARKER for further information.



Caution: It might be necessary to fit a filter at the servo-drive output if the length of the cable exceeds 25 m. Consult us.

3.8.4. Ground connection



DANGER: For the safety, you need to connect stator to the ground. Consult local regulation to choose the cross section and to know resistance limits to check ground continuity between frame and ground wire.

3.8.5. Motor cable

The motor cables are flexible, so cables can take any direction. Please refer to the outline drawing to know bending radius.



The electrical connection on SKW servomotor in kit version is realized by high performance cable. The motor cable section depends of the motor current level. Please refer to the outline drawing to know the cross section (depending of torque/speed characteristics letter code).



Caution: The motor cables are designed for high current density, so cable surface can reach temperatures exceeding 100°C.



Caution: The wiring must comply with the drive commissioning manual and with recommended cables.

Caution: Section motor cable is lower than commissioning section cable between motor and drive due to high performance motor cable design. Do not take the same cable section than motor ones.



Attention: Do not mix feedback wires with motor wires to avoid EMI (electromagnetic interference). EMI risk to set default the drive. So, careful to separate resolver and motor wires.



Attention: Do not mix feedback wires with motor wires to avoid EMI (electromagnetic interference). EMI risk to set default the drive. So, careful to separate resolver and motor wires.

4. COMMISSIONING AND USE

4.1. Instructions for commissioning and use

4.1.1. Equipment delivery

All spindle servomotors undergo a thorough quality control procedure before shipping. Check the condition of the servomotor when carefully removing it from its packaging. Check that the information on the identification plate corresponds to your order. The package includes required document and accessories.



Warning: If the equipment has been damaged during transit, the recipient should **immediately** complain to the carrier by registered letter within 24 hours.

4.1.2. Handling

Spindle Motors are delivered in two part, rotor and stator divided.







DANGER: Do not handle the rotor with the help of electrical cables or use any other inappropriate method. Use non-magnetic material to handle rotor.

4.1.3. Storage

Before being mounted, the motor has to be stored in a dry place, without rapid or important temperature variations in order to avoid condensation. During storage, the ambient temperature must be kept between -20 and +60°C. If the high-speed motor has to be stored for a long time, verify that the surfaces are coated with corrosion proof product.

4.2. Machine integration

4.2.1. General warnings

	<p><u>Caution</u>: The integrator bears the entire responsibility for the preparation of the machine design.</p>
	<p><u>Danger</u> : The integrator must certify the motor by an approved organism to comply with all the regulations (CE, ...) and perform all the mandatory routine tests (exemples : IEC60034...)</p>
	<p><u>Attention</u>: Rotor has strong permanent magnets. It creates strong attraction force that can crush fingers or hands. Firmly hold the rotor and move away all magnetic parts. <u>Caution</u>: Clean the working area of all ferromagnetic part such as tools, screws, steel particles. Use wood table to work or make machine assembly.</p>
	<p><u>Caution</u>: Anyone wearing pacemaker, hearing aid, watches, magnetic data storage device must keep at 1 meter from kit motor.</p>
	<p><u>Caution</u>: Before mounting the motor, the surface must be cleaned.</p>

4.2.2. Tightening torque

The table below gives the average tightening torques required regarding the fixing screw diameter.

Screw diameter	Tightening torque
M2 x 0.35	0.35 N.m
M2.5 x 0.4	0.6 N.m
M3 x 0.5	1.1 N.m
M3.5 x 0.6	1.7 N.m
M4 x 0.7	2.5 N.m
M5 x 0.8	5 N.m
M6 x 1	8.5 N.m
M7 x 1	14 N.m
M8 x 1.25	20 N.m

Screw diameter	Tightening torque
M9 x 1.25	31 N.m
M10 x 1.5	40 N.m
M11 x 1.5	56 N.m
M12 x 1.75	70 N.m
M14 x 2	111 N.m
M16 x 2	167 N.m
M18 x 2.5	228 N.m
M20 x 2.5	329 N.m
M22 x 2.5	437 N.m
M24 x 3	564 N.m



Warning: After 15 days, check all tightening torques on all screw and nuts.

4.2.3. Rotor integration step by step

The axial attraction force (F_a) during the rotor insertion in the stator is:

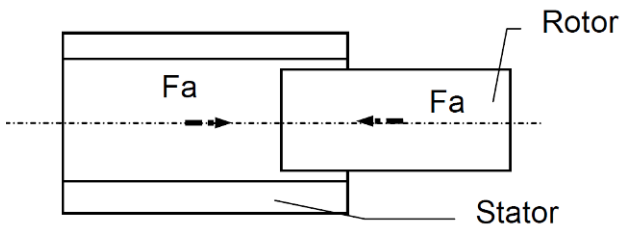

Motor	Axial attraction force (N)
SKW073	100
SKW082	120
SKW091	120
SKW096	100

The radial attraction force is proportional to the rotor eccentricity x :

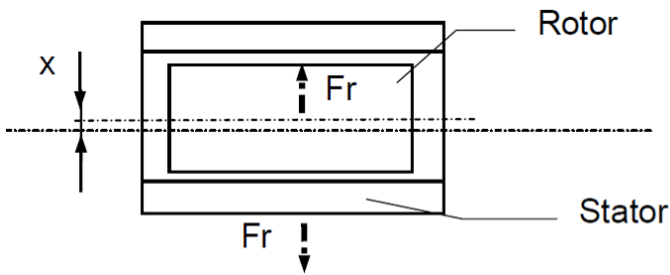

Motor	Radial attraction force F_r at the maximum rotor eccentricity (N)
SKW073-050	150
SKW073-100	300
SKW073-150	450
SKW073-200	600
SKW082-046	200
SKW082-092	400
SKW082-138	600
SKW082-184	800
SKW091-046	200
SKW091-092	400
SKW091-138	600
SKW091-184	800
SKW096-046	150
SKW096-092	300
SKW096-138	460
SKW096-184	620

Step 1

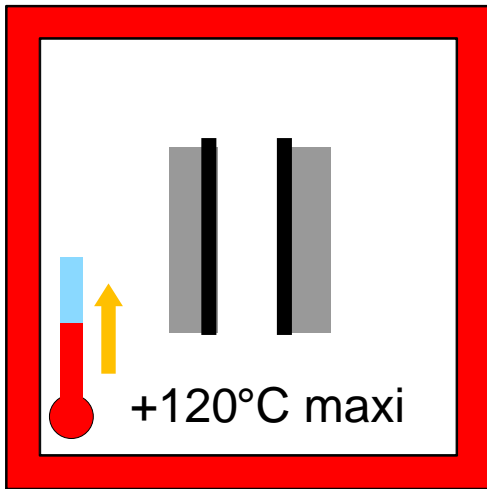

Increase rotor temperature to 120°C

Step 2

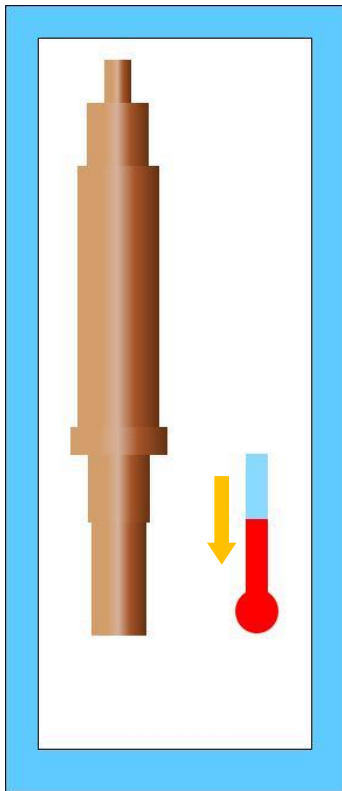

Decrease shaft temperature with liquid nitrogen

Motor	Temperature
SKW073	-175°C
SKW082	-155°C
SKW091	-155°C
SKW096	-110°C

Step 3

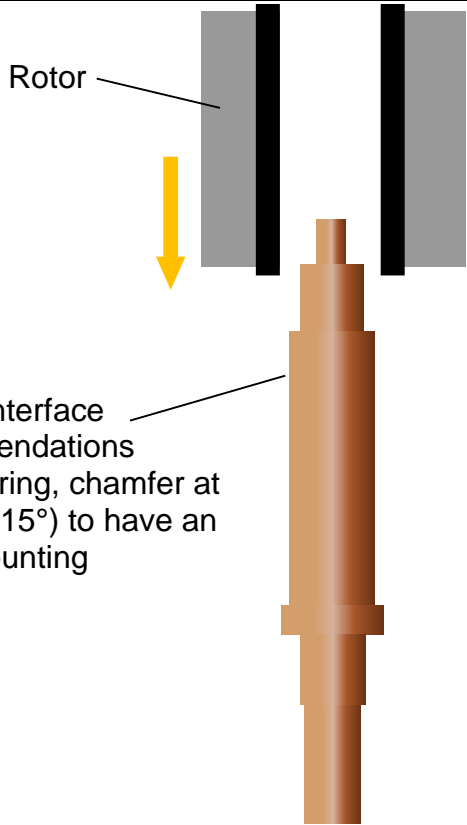

Push down the rotor on the shaft
Make sure you have followed the shaft interface instruction.

Step 4

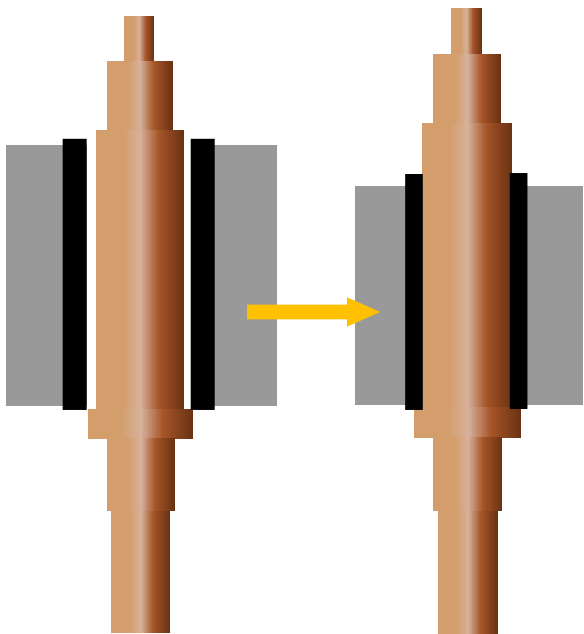

After fitting, let rotor+shaft go back to ambient temperature

Step 5

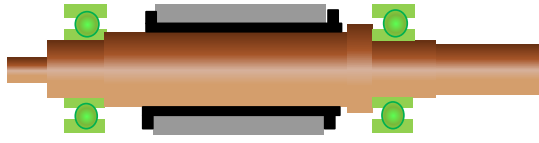

Rotor balancing

For high speed application, rotor must be balanced with bearings and shaft.

Balancing recommended level : G1

Rotors are not balanced before delivery. The electro-spindle manufacturer must balance the complete spindle rotor (shaft, bearings and rotor) using an appropriate method: for example, by removing or add material from shaft.



Caution: In case of drilling, be careful about shaving of metal with magnetic part.

We recommend to add material (screws)



Caution: Balancing must never be made by removing material from the rotor sides, the rotor lamination or any other part of the rotor.

4.2.4. Stator integration step by step

Step 1	
	<p>Assemble O-Ring seal on water jacket.</p> <p>O-Ring information's for standard water jacket in chapter "O-Ring specification".</p>

Step 2	
	<p>Prepare the cooling jacket for his integration : Water inlet and outlet must be aligned with the cables inlet</p> <p>Make sure you have followed the cooling jacket interface instructions.</p> <p>The 4 O-rings must be greased with an ordinary lubricant before mounting to avoid damages and leakages</p>

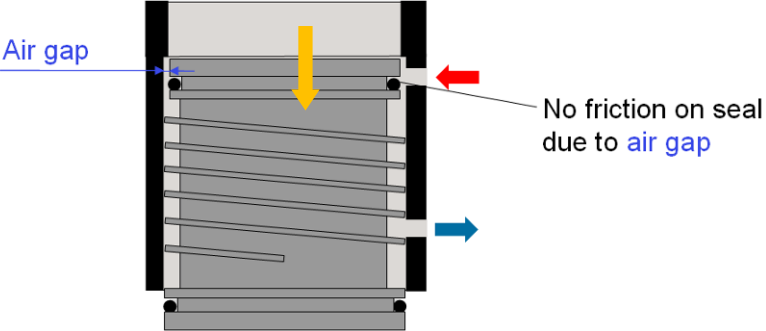
Step 3	
 <p>Air gap</p> <p>No friction on seal due to air gap</p>	Push down the cooling jacket on the water jacket.

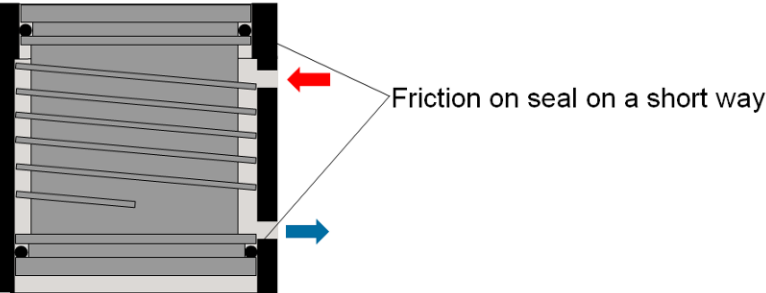
Step 4	
 <p>Friction on seal on a short way</p>	Cooling jacket instructions have been designed to minimize the O-Ring seal friction.

	<p>Caution: Be careful not to make damage on the O-ring during the mounting to avoid leakage. After last mounting step, it's recommended to realize a waterproof test with 10 bars air pressure during 30 minutes and check if there is not pressure decreasing.</p>
---	---

4.2.5. Rotor assembly into stator step by step

Step 1

Labels in diagram:

- Rear flange
- Rotor on the shaft
- Bearings
- Housing with stator
- Spring ring
- Front flange
- Clean workbench – no magnet part

Instructions:

- Screw the stator onto the front flange.
- Put the stator onto workbench.
- Put spring ring.
- Prepare rotor : fit onto rear flange.

Step 2

Labels in diagram:

- Tooling : Guide is an extra shaft
- Adjusted - H7 / g6

Instructions:

- For an easier assembly, use an extra shaft to guide rotor on stator to avoid gluing due to magnetic parts.

Step 3

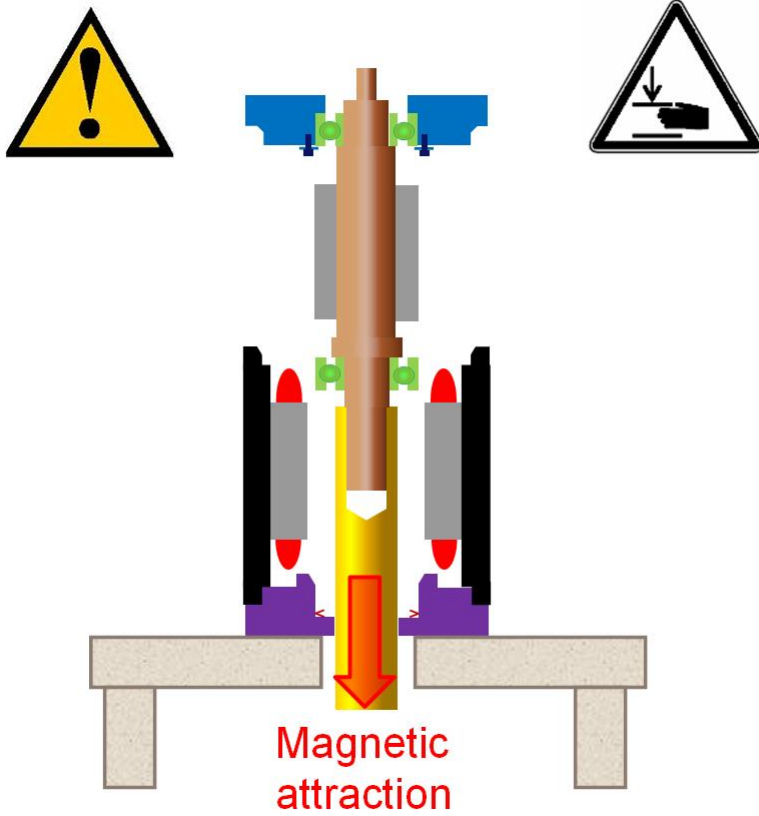

Danger : do not put your hand inside the motor during way-down.

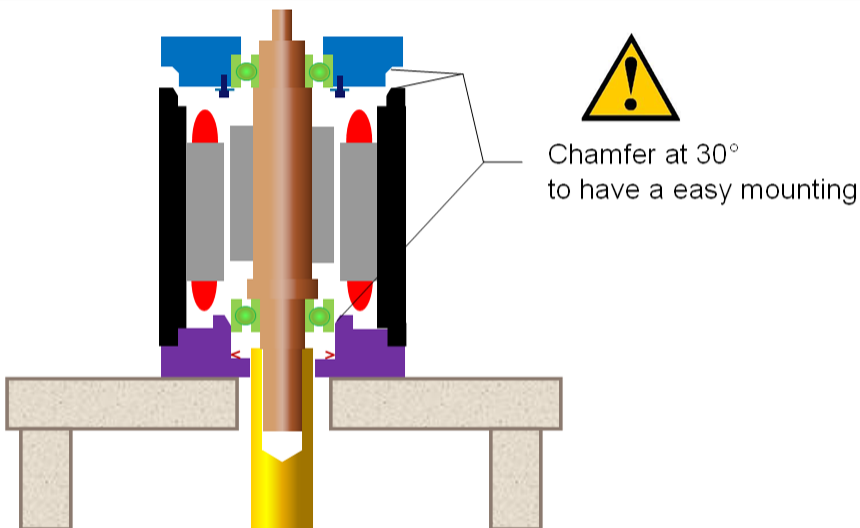

Make sure you have done chamfers at 30°.

Step 4

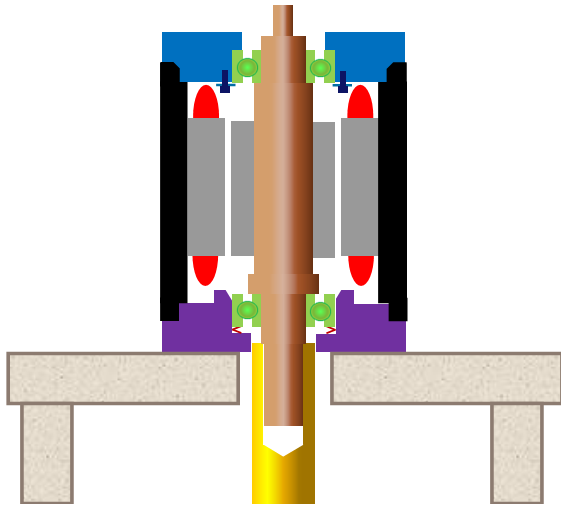

Screw the rear flange on the stator to close motor.

Step 5

Last step is the encoder or resolver mounting



Caution: After 15 days, check all tightening torques on screws and nuts

4.3. Electrical connections



Danger: Do not connect the kit to any electric supply . Only the motor can be connected to an electric supply.



Danger: Check that the power to the electrical cabinet is off prior to making any connections.



Caution: The wiring must comply with the drive commissioning manual and with recommended cables.
Caution: Section motor cable is lower than commissioning section cable between motor and drive due to high performance motor cable design. Do not take the same cable section than motor.



Danger: The spindle servomotor must be earthed by connecting to an unpainted section of the motor.



Caution: The motor cables are designed for high current density, so cable surface can reach temperatures exceeding 100°C.



Caution: After 15 days, check all tightening torques on cable connection.

Please, read §3.7 "Electrical connection" to have information about cable. Many useful informations are already available in the drive documentations.

The motor must be connected to the servo amplifier according to the drive user manual. The color code given in the table C must be followed :

Signal	Color
U	Black
V	White
W	Red



The motor is shipped without a ground cable. It is mandatory to connect a (green-yellow) ground cable between the spindle motor frame and machine. The ground cable cross-section must be the same as the power cable cross-section

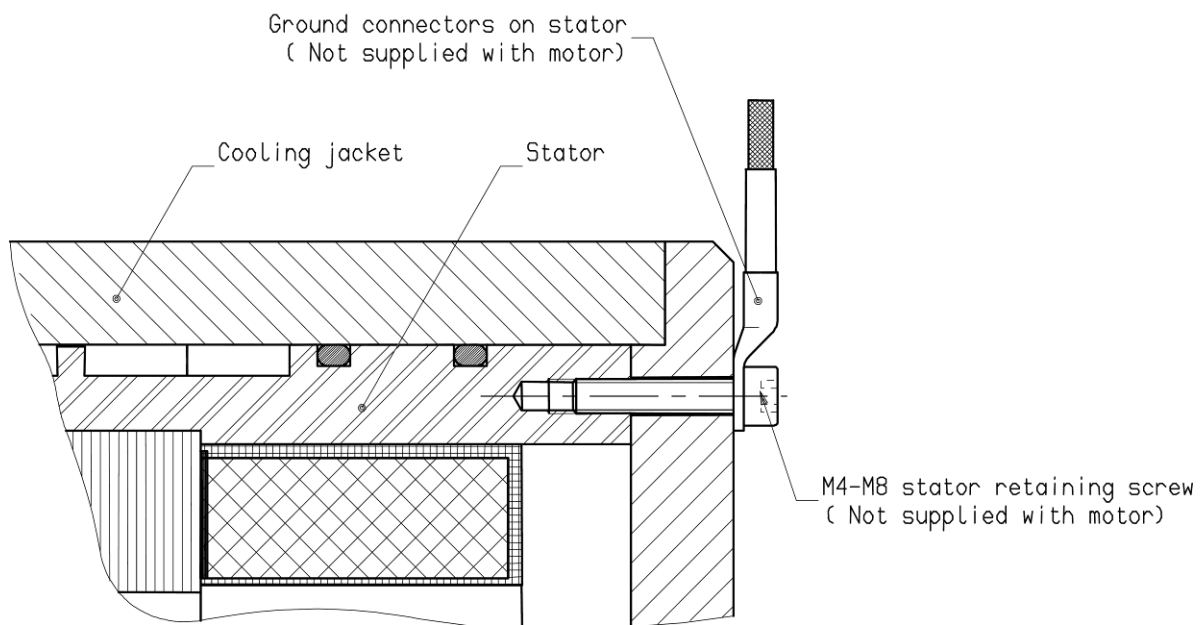



Before applying power:

- ✓ Check there is no damage on winding or cable due the mounting by a dielectric test
- ✓ Check all external wiring circuits of the system – power, control, motor and earth connections.
- ✓ Ensure that nobody is working on another part of the system who will be affected by powering up
- ✓ Ensure that other equipment will not be adversely affected by powering up.

4.4. Encoder cable handling

	<p><u>Danger:</u> before any intervention the drive must be stopped in accordance with the procedure.</p>
---	---

	<p><u>Caution:</u> It is forbidden to disconnect the Encoder cable under voltage (high risk of damage and sensor destruction).</p>
---	--

	<p><u>Attention:</u> Do not mix feedback wires with motor wires to avoid EMI (electromagnetic interference). EMI risk to set default the drive. So, careful to separate resolver and motor wires.</p>
---	---

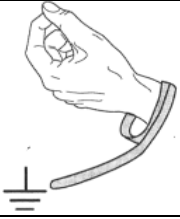
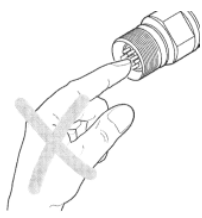
	<p><u>Warning:</u> Always wear an antistatic wrist strap during encoder handling.</p>
	<p><u>Warning:</u> Do not touch encoder contacts (risk of damage due to electrostatic discharges ESD).</p>

4.5. Tests

The motor components delivered by Parker are tested :

- dielectric test,
- surge test,
- winding resistance and inductance,
- direction of rotation,
- rotor flux.

But complete motor must be tested for safety reason and to comply with the regulations (CE,...).

	<p>Danger : The integrator must certify the motor by an approved organism to comply with all the regulations (CE, ...) and perform all the mandatory routine tests (exemples : IEC60034...).</p> <p>The typical process is the qualification of a complete unit and routine tests (including safety tests) on each unit produced</p>
---	---

Exemple of a summary of the recommended safety tests, to be validated bu an approved organism.

Attention : other could be needed in accordance with regulations:

- **The continuity of the grounding circuit :**

On **each** complete unit, the resistance between any conductive point and the grounding conductor shall not exceed than 100mΩ. This test shall be performed before the dielectric tests. (EN60204-1: Safety of the machine)

- **Below exemples of dielectric tests performed on each complete unit (Sefelec SMG50 can be used) for a 400V supply :**

Dielectric Test	Motor U,V,W wires	Thermal sensor wires	Brake wires	Resolver wires	Frame	Test duration, depends on power
Motor	1800V for 400 V	Connected on Frame	Connected on Frame	Connected on Frame	0V	1min
Thermal sensor	Connected on Frame	1800V for 400 V	Connected on Frame	Connected on Frame	0V	1min
...	...					

4.6. Troubleshooting

Some symptoms and their possible causes are listed below. This list is not comprehensive. Whenever an operating incident occurs, consult the relevant servo drive installation instructions (the troubleshooting display indications will help you in your investigation) or contact us at: <http://www.parker.com/eme/repairservice>.

<p>You note that the motor does not turn by hand when the motor is not connected to the drive.</p>	<ul style="list-style-type: none"> • Check there is no mechanical blockage or if the motor terminals are not short-circuited.
<p>You have difficulty starting the motor or making it run</p>	<ul style="list-style-type: none"> • Check on the fuses, the voltage at the terminals (there could be an overload or the bearings could be jammed), also checks on the load current. • Check on any thermal protection, its connection and how it is set in the drive. • Check on the servomotor insulation (if in doubt, carry out hot and cold measurements). <p>The minimum insulation resistance value measured under a max. 50V DC is 50 MΩ:</p> <ul style="list-style-type: none"> • Between the phase and the casing • Between the thermal protection and the casing • Between the brake coil and the casing <ul style="list-style-type: none"> - Between the resolver coils and the casing.
<p>You find that the motor speed is drifting</p>	<ul style="list-style-type: none"> • Reset the offset of the servoamplifier after having given a zero instruction to the speed setpoint input.
<p>You notice that the motor is racing</p>	<ul style="list-style-type: none"> • Check the speed set-point of the servo drive. • Check you are well and truly in speed regulation (and not in torque regulation). • Check the encoder setting • Check on the servomotor phase order: U, V, W
<p>You notice vibrations</p>	<ul style="list-style-type: none"> • Check the encoder and tachometer connections, the earth connections (carefully) and the earthing of the earth wire, the setting of the servo drive speed loop, tachometer screening and filtering. • Check the stability of the secondary voltages. • Check the rigidity of the frame and motor support.
<p>You think the motor is becoming unusually hot</p>	<ul style="list-style-type: none"> • It may be overloaded or the rotation speed is too low : check the current and the operating cycle of the torque motor • Check if the mounting surface is enough or if this surface is not a heat source – see §3.5 cooling. • Friction in the machine may be too high : <ul style="list-style-type: none"> - Test the motor current with and without a load. - Check the motor does not have thermal insulation.

You find that the motor is too noisy	Several possible explanations : <ul style="list-style-type: none">• Unsatisfactory mechanical balancing• Defective coupling• Loosening of several pieces• Poor adjustment of servo drive or position loop : check rotation in open loop
The motor is warmer on its top	Air bubbles can be stocked in the water cooling circuit. You need to purge the circuit or to double the water flow rate during 10 minutes to remove the air bubbles.