



---

# HEALTHY SOLENOID VALVE SERIES

Fluid Control Solutions for Beverage Dispensing.



### **WARNING - USER RESPONSIBILITY**

**FAILURE OR IMPROPER SELECTION OR IMPROPER USE OF THE PRODUCTS DESCRIBED HEREIN OR RELATED ITEMS CAN CAUSE DEATH. PERSONAL INJURY AND PROPERTY DAMAGE.**

- This document and other information from Parker-Hannifin Corporation, its subsidiaries and authorized distributors provide product or system options for further investigation by users having technical expertise.
- The user, through its own analysis and testing, is solely responsible for making the final selection of the system and components and assuring that all performance, endurance, maintenance, safety and warning requirements of the application are met. The user must analyze all aspects of the application, follow applicable industry standards, and follow the information concerning the product in the current product catalog and in any other materials provided from Parker or its subsidiaries or authorized distributors.
- To the extent that Parker or its subsidiaries or authorized distributors provide component or system options based upon data or specifications provided by the user, the user is responsible for determining that such data and specifications are suitable and sufficient for all applications and reasonably foreseeable uses of the components or systems.

## Fluid Control Solutions for Healthy Beverage Dispense

<b>Parker Fluid Control Solutions Europe</b> .....	<b>4</b>
<b>Technical vocabulary for using tables</b> .....	<b>6</b>
<b>General description</b> .....	<b>7</b>
121ZH Series - 2 way normally closed .....	<b>8</b>
121KH Series - 2 way normally closed .....	<b>10</b>
121FH Series - 2 way normally closed .....	<b>12</b>
131ZH Series - 3 way normally closed .....	<b>14</b>
131KH Series - 3 way normally closed .....	<b>16</b>
131FH Series - 3 way normally closed .....	<b>18</b>
121KH Series with manual flow regulator - 2 way normally closed ...	<b>20</b>
121WH Series Compact - 2 way normally closed .....	<b>22</b>
131WH Series Compact - 3 way normally closed .....	<b>24</b>
<b>Housing</b> .....	<b>26</b>
<b>Electrical parts</b> .....	<b>27</b>
<b>Accessories</b> .....	<b>32</b>
<b>How to order</b> .....	<b>33</b>

# Parker Fluid Control Solutions Europe - FCSE

## Who we are?

The Fluid Control Solutions Europe (FCSE) Business Unit is part of Fluid and Climate Controls Division Europe (FCCE) of Parker Hannifin, the global leader in Motion and Control Technologies.

FCSE core competences are the development and manufacturing of an extremely diverse range of fluid control products, including solenoid valves and pressure regulators.



Gessate (Italy)  
Fluid Controls Solutions Europe

## History

Parker FCSE has been a leading player in the manufacturing and development of solenoid valve technologies for over 60 years, with continuous research and development bringing innovative solutions to the marketplace, for example leading the way in the utilisation of synthetic ruby for critical water applications or the unsurpassed reliability and precision of our pressure regulators. The expertise accumulated and developed through the years is evident in the superior quality of FCSE solutions.

## Markets

Our products and solutions are typically designed for markets including Industrial Equipment, Industrial Automation, Mobile, Transportation, Life Sciences, Beverage dispensing and for Fluid and Process Control.

## Benefits

The modular concept of our products, having separate solenoid valves and electrical parts, provides the customer with increased flexibility by allowing numerous combinations. This additional flexibility can enable distributors to greater reduce valve inventory levels, whilst retaining the same number of capabilities. Parker also has unrivalled experience in developing customised product solutions complying with the highest technical, environmental, energy and service life requirements.

# Introduction

Parker Fluid Control Solutions Europe is your ideal partner offering the broadest range of solutions for beverage dispensers.

Thanks to Parker's extensive expertise and our dedication to innovation we are today in the position to offer a broad range of robust and exclusive solutions.

In fact, all our products have been developed in order to achieve superior performance in high demanding professional equipment.

## Market segments

- **Professional coffee machines**
- **Vending distributors for hot drinks**
- **Semi-professional and domestic coffee machines**
- **Automatic water dispensers**

## Applications

Typical applications in beverage dispensers are:

- **Water loading control of a boiler**
- **Steam control**
- **Cold, hot and superheated water shut-off**
- **Cold water and steam mixing**
- **Steam pressure control (pressure switch)**

## Food Certifications Compliance

- **NSF 169**
- **1935/2004/CE**
- **DM174 (Potable Water)**

## Benefits

Parker was the first company to develop the ruby sealing system for solenoid valves. Our expertise in this technology makes our products extremely efficient against limescale build-up.

High performance and low power consumption electrical components, with a wide range of configurations and approvals are available.

The strong and robust design provides you with high reliability, minimizing the risk of failures when your equipment is operating and avoiding downtime.

# Technical vocabulary

The basic technical features of each solenoid valve model are indicated in the tables with the following headings:

<b>Port size:</b>	Fitting dimensions are defined as threaded in inches (G) or sub-base, when a flat interface for ports is adopted.
<b>Orifice:</b>	Main orifice diameter in millimetres (nominal diameter).
<b>Flow factors:</b>	Defined as the quantity of water, temp. between +5°C and +30°C, which flows through the solenoid valve with a pressure drop of 1 bar (100 KPa-0.1 MPa), in m <sup>3</sup> /h (cubic metres per hour) and in l/min (liters per minute).
<b>Minimum pressure:</b>	The lowest differential pressure required for operation, in bar.
<b>Maximum differential pressure (MOPD):</b>	The highest working differential pressure with 90% of the rated voltage (-10% V <sub>n</sub> ).
<b>Fluid maxi. temperature:</b>	Maximum admissible temperature for the media used. In °C.
<b>Seat disc:</b>	Material used for the seat discs.
<b>Pressure vessel:</b>	The mechanical part of a solenoid valve.
<b>Electrical part:</b>	Compatible electrical part reference. Our tables are indicating the most standard solution. Please refer to "Coil group" column to identify alternative electrical parts.
<b>Power consumption:</b>	Power consumption of a specific electrical part on selected pressure vessel, rated by AC and DC, in W. Power consumption must be considered in cold condition for the coil, at T <sub>Amb</sub> : +20°C. For 481865 series, power consumption indicated in the tables must be considered in warm conditions. See also details in each electrical part description (pages 27-31).
<b>Weight:</b>	Weight of the complete valve without accessories, in grams.
<b>Safe body working pressure:</b>	Ref. EN 1333:2007 (PN) the maximum admissible pressure at 20°C which can be applied to the solenoid valve to check the tightness of the mechanical seals (threads, welds) and the mechanical resistance of the materials.
<b>Coil group:</b>	Alternative electrical parts to the main one listed in the chart, having particular features (approvals, insulation classes). Please refer to electrical parts description (pages 27-31) to select alternative coils.

# General description

<b>Material specifications:</b>	A description of the materials used for each solenoid valve family.
<b>Installation:</b>	The valves can be mounted in any position. It is however recommended to install them with the coil in vertical position above the body.
<b>Media:</b>	These valves have been developed to achieve the best performances with cold and hot water, superheated water and steam. Within the main description of the family you will be able to find out the recommended media and application.
<b>Electrical parts:</b>	Electrical parts compatible with each solenoid has been indicated directly in the main datasheets you will find at pages 8 to 24. Details about electrical parts specifications are available at pages 27-31. Please consult also the "How to order" section at page 33 on how to select the product configuration which fits your application requirements.

## Product selection

This catalogue has been designed to make selection as easy as possible. The structure allows you to find your valve step by step, beginning with the most basic features and gradually focusing on more precise details.

To make the selection easier we have included in each valve description an indication about typical applications, like water loading and cold water control, superheated water and steam control.

In the first column you will be able to identify the port size, and proceeding you will meet all the available product solution.

# 2/2

## 121ZH Series 2 way valves, normally closed



Our Parker range of healthy solenoid valves provides you with top-class performance as a result of the entire stainless steel structure of the valve pilots.

Compact and robust at the same time, the stainless steel nozzle included in all 32mm operated range improves valve life, endurance and resistance to lime-scale build up effect. A wide range of electrical parts can be used with this valve, including IP65 VDE and UL solutions. Typical applications include cold water loading function or hot water-steam on/off control.

**Valve body:** forged brass, CW510L UNI EN 12165  
**Seals:** FDA FKM, Ruby  
**Sleeve, plungers and nozzle:** stainless steel



### 1/8" Pipe Mounting Connection

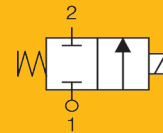

Port Size	Orifice Ø mm	Flow Factors		Operating Pressure Differential			Fluid Temperature		Seat Seal	Parker Valves			Power		Coil Group	Dwg N°
		Kv l/min	KV m³/h	Min. Bar	Max. (MOPD) AC bar	DC bar	Min. °C	Max. °C		Valve Ref.	Housing Ref.	Coil Ref.	AC W	DC W		
G1/8"	1.0	0.7	0.04	0	20	18	-10	140	FDA FKM	121ZH1010	2995	481865	9	8	2.0, 2.1, 2.2	1
	1.5	1.5	0.09	0	20	18	-10	140	FDA FKM	121ZH1015	2995	481865	9	8	2.0, 2.1, 2.2	
	2.0	2.6	0.16	0	20	15	-10	140	FDA FKM	121ZH1020	2995	481865	9	8	2.0, 2.1, 2.2	
	2.5	3.5	0.21	0	19	14.5	-10	140	FDA FKM	121ZH1025	2995	481865	9	8	2.0, 2.1, 2.2	
	3.0	4.5	0.27	0	13	8.5	-10	140	FDA FKM	121ZH1030	2995	481865	9	8	2.0, 2.1, 2.2	
	1.0	0.7	0.04	0	20	18	-10	140	Ruby	121ZH0010	2995	481865	9	8	2.0, 2.1, 2.2	
	1.5	1.5	0.09	0	20	18	-10	140	Ruby	121ZH0015	2995	481865	9	8	2.0, 2.1, 2.2	
	2.0	2.6	0.16	0	20	15	-10	140	Ruby	121ZH0020	2995	481865	9	8	2.0, 2.1, 2.2	
	2.5	3.5	0.21	0	19	14.5	-10	140	Ruby	121ZH0025	2995	481865	9	8	2.0, 2.1, 2.2	
NPT 1/8"	3.0	4.5	0.27	0	13	8.5	-10	140	Ruby	121ZH0030	2995	481865	9	8	2.0, 2.1, 2.2	
	1.0	0.7	0.04	0	20	18	-10	140	FDA FKM	U121ZH1010	2995	481865	9	8	2.0, 2.1, 2.2	
	1.5	1.5	0.09	0	20	18	-10	140	FDA FKM	U121ZH1015	2995	481865	9	8	2.0, 2.1, 2.2	
	2.0	2.6	0.16	0	20	15	-10	140	FDA FKM	U121ZH1020	2995	481865	9	8	2.0, 2.1, 2.2	
	2.5	3.5	0.21	0	19	14.5	-10	140	FDA FKM	U121ZH1025	2995	481865	9	8	2.0, 2.1, 2.2	
	3.0	4.5	0.27	0	13	8.5	-10	140	FDA FKM	U121ZH1030	2995	481865	9	8	2.0, 2.1, 2.2	
	1.0	0.7	0.04	0	20	18	-10	140	Ruby	U121ZH0010	2995	481865	9	8	2.0, 2.1, 2.2	
	1.5	1.5	0.09	0	20	18	-10	140	Ruby	U121ZH0015	2995	481865	9	8	2.0, 2.1, 2.2	
	2.0	2.6	0.16	0	20	15	-10	140	Ruby	U121ZH0020	2995	481865	9	8	2.0, 2.1, 2.2	
2.5	3.5	0.21	0	19	14.5	-10	140	Ruby	U121ZH0025	2995	481865	9	8	2.0, 2.1, 2.2		
3.0	4.5	0.27	0	13	8.5	-10	140	Ruby	U121ZH0030	2995	481865	9	8	2.0, 2.1, 2.2		

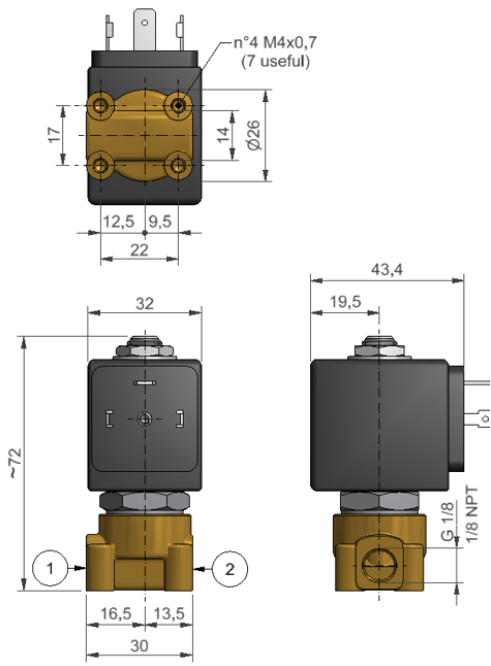

Dimensional drawing N° 1

All dimensions are in mm

# 2/2

## 121KH Series 2 way valves, normally closed



Our Parker range of healthy solenoid valves provides you with top-class performance as a result of the entire stainless steel structure of the valve pilots.

Compact and robust at the same time, the stainless steel nozzle included in all 32mm operated range improves valve life, endurance and resistance to lime-scale build up effect. A wide range of electrical parts can be used with this valve, including IP65 VDE and UL solutions. Typical applications include cold water loading function or hot water-steam on/off control.

**Valve body:** forged brass, CW510L UNI EN 12165

**Seals:** FDA FKM, Ruby

**Sleeve, plungers and nozzle:** stainless steel



### 1/4" Pipe Mounting Connection

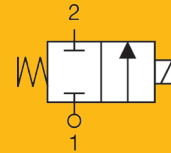

Port Size	Orifice Ø mm	Flow Factors		Operating Pressure Differential			Fluid Temperature		Seat Seal	Parker Valves			Power		Coil Group	Dwg N°
		Kv l/min	KV m³/h	Min. Bar	Max. (MOPD) AC bar	DC bar	Min. °C	Max. °C		Valve Ref.	Housing Ref.	Coil Ref.	AC W	DC W		
G1/4	1.5	1.5	0.09	0	20	18	-10	140	FDA FKM	121KH1015	2995	481865	9	8	2.0, 2.1, 2.2	2
	2.0	2.6	0.16	0	20	15	-10	140	FDA FKM	121KH1020	2995	481865	9	8	2.0, 2.1, 2.2	
	2.5	3.5	0.21	0	19	14.5	-10	140	FDA FKM	121KH1025	2995	481865	9	8	2.0, 2.1, 2.2	
	3.0	4.5	0.27	0	13	8.5	-10	140	FDA FKM	121KH1030	2995	481865	9	8	2.0, 2.1, 2.2	3
	4.0	5.5	0.33	0	9	6	-10	140	FDA FKM	121KH1040	2995	481865	9	8	2.0, 2.1, 2.2	
	5.0	9.5	0.57	0	2.5	2	-10	140	FDA FKM	121KH1050	2995	481865	9	8	2.0, 2.1, 2.2	
	1.5	1.5	0.09	0	20	18	-10	140	Ruby	121KH0015	2995	481865	9	8	2.0, 2.1, 2.2	2
	2.0	2.6	0.16	0	20	15	-10	140	Ruby	121KH0020	2995	481865	9	8	2.0, 2.1, 2.2	
	2.5	3.5	0.21	0	19	14.5	-10	140	Ruby	121KH0025	2995	481865	9	8	2.0, 2.1, 2.2	
	3.0	4.5	0.27	0	13	8.5	-10	140	Ruby	121KH0030	2995	481865	9	8	2.0, 2.1, 2.2	

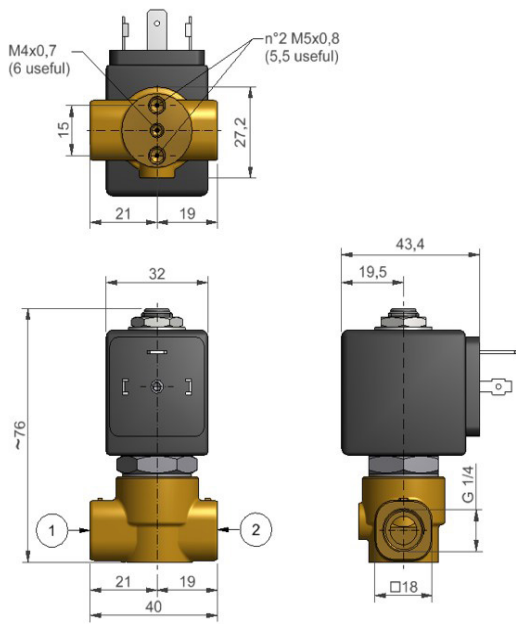

Dimensional drawing N° 2

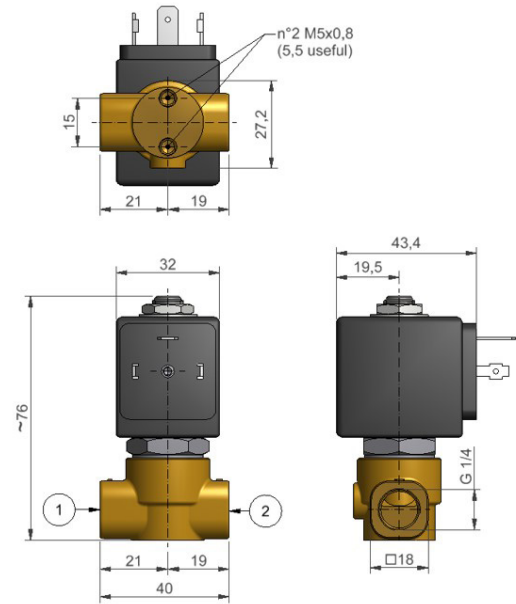

Dimensional drawing N° 3

All dimensions are in mm

# 2/2

## 121FH Series 2 way valves, normally closed



Our Parker range of healthy solenoid valves provides you with top-class performance as a result of the entire stainless steel structure of the valve pilots.

Compact and robust at the same time, the stainless steel nozzle included in all 32mm operated range improves valve life, endurance and resistance to lime-scale build up effect. A wide range of electrical parts can be used with this valve, including IP65 VDE and UL solutions. Typical applications include cold water loading function or hot water-steam on/off control.

- Valve body:** forged brass, CW510L UNI EN 12165
- Seals:** FDA FKM, Ruby
- Sleeve, plungers and nozzle:** stainless steel



### Flanged (SB) Connection

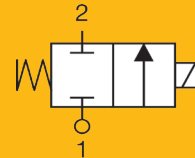

Port Size	Orifice Ø mm	Flow Factors		Operating Pressure Differential			Fluid Temperature		Seat Seal	Parker Valves			Power		Coil Group	Dwg N°
		Kv	KV	Min.	Max. (MOPD)		Min.	Max.		Valve Ref.	Housing Ref.	Coil Ref.	AC	DC		
		l/min	m³/h	Bar	AC bar	DC bar	°C	°C					W	W		
SB	1.5	1.4	0.08	0	20	20	-10	140	FDA FKM	<b>121FH1015</b>	<b>2995</b>	<b>481865</b>	9	8	2.0, 2.1, 2.2	4
	2.0	2.3	0.14	0	20	20	-10	140	FDA FKM	<b>121FH1020</b>	<b>2995</b>	<b>481865</b>	9	8	2.0, 2.1, 2.2	
	2.5	3.0	0.18	0	20	14	-10	140	FDA FKM	<b>121FH1025</b>	<b>2995</b>	<b>481865</b>	9	8	2.0, 2.1, 2.2	
	3.0	3.4	0.2	0	17	10	-10	140	FDA FKM	<b>121FH1030</b>	<b>2995</b>	<b>481865</b>	9	8	2.0, 2.1, 2.2	
	1.5	1.4	0.08	0	20	20	-10	140	Ruby	<b>121FH0015</b>	<b>2995</b>	<b>481865</b>	9	8	2.0, 2.1, 2.2	
	2.0	2.3	0.14	0	20	20	-10	140	Ruby	<b>121FH0020</b>	<b>2995</b>	<b>481865</b>	9	8	2.0, 2.1, 2.2	
	2.5	3.0	0.18	0	20	14	-10	140	Ruby	<b>121FH0025</b>	<b>2995</b>	<b>481865</b>	9	8	2.0, 2.1, 2.2	
	3.0	3.4	0.2	0	17	10	-10	140	Ruby	<b>121FH0030</b>	<b>2995</b>	<b>481865</b>	9	8	2.0, 2.1, 2.2	

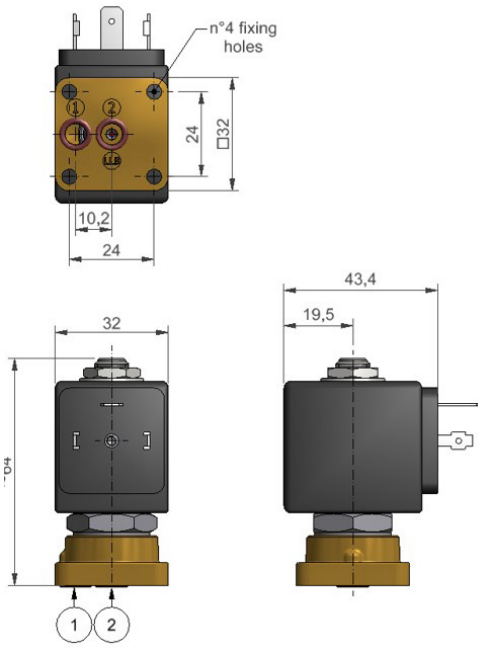

Dimensional drawing N° 4

All dimensions are in mm

# 3/2

## 131ZH Series 3 way valves, normally closed



Our Parker range of healthy solenoid valves provides you with top-class performance as a result of the entire stainless steel structure of the valve pilots.

Compact and robust at the same time, the stainless steel nozzle included in all 32mm operated range improves valve life, endurance and resistance to lime-scale build up effect. A wide range of electrical parts can be used with this valve, including IP65 VDE and UL solutions. Typical applications include cold water loading function or hot water-steam on/off control.

**Valve body:** forged brass, CW510L UNI EN 12165

**Seals:** FDA FKM, Ruby

**Sleeve, plungers and nozzle:** stainless steel



### 1/8" Pipe Mounting Connection

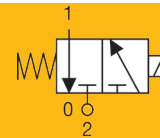

Port Size	Orifice Ø	Flow Factors		Operating Pressure Differential			Fluid Temperature		Seat Seal	Parker Valves			Power		Coil Group	Dwg N°
		Kv	KV	Min.	Max. (MOPD)		Min.	Max.		Valve Ref.	Housing Ref.	Coil Ref.	AC W	DC W		
	mm	l/min	m³/h	Bar	AC bar	DC bar	°C	°C								
G1/8"	1.5	1.4	0.08	0	20	20	-10	140	FDA FKM	<b>131ZH1115</b>	<b>2995</b>	<b>481865</b>	9	8	2.0, 2.1, 2.2	5
	2.0	2.0	0.12	0	14	14	-10	140	FDA FKM	<b>131ZH1120</b>	<b>2995</b>	<b>481865</b>	9	8	2.0, 2.1, 2.2	
	2.5	3.0	0.18	0	8.5	8.5	-10	140	FDA FKM	<b>131ZH1125</b>	<b>2995</b>	<b>481865</b>	9	8	2.0, 2.1, 2.2	
	3.0	3.7	0.22	0	6	6	-10	140	FDA FKM	<b>131ZH1130</b>	<b>2995</b>	<b>481865</b>	9	8	2.0, 2.1, 2.2	
	1.5	1.4	0.08	0	20	20	-10	140	Ruby	<b>131ZH1115</b>	<b>2995</b>	<b>481865</b>	9	8	2.0, 2.1, 2.2	
	2.0	2.0	0.12	0	14	14	-10	140	Ruby	<b>131ZH1120</b>	<b>2995</b>	<b>492425</b>	9	8	2.0, 2.1, 2.2	
	2.5	3.0	0.18	0	8.5	8.5	-10	140	Ruby	<b>131ZH0125</b>	<b>2995</b>	<b>481865</b>	9	8	2.0, 2.1, 2.2	
	3.0	3.7	0.22	0	6	6	-10	140	Ruby	<b>131ZH0130</b>	<b>2995</b>	<b>481865</b>	9	8	2.0, 2.1, 2.2	
G1/8"	1.5	1.4	0.1	0	20	20	-10	140	FDA FKM	<b>131ZH1315</b>	<b>2995</b>	<b>481865</b>	9	8	2.0, 2.1, 2.2	6
	2.0	2.0	0.1	0	14	14	-10	140	FDA FKM	<b>131ZH1320</b>	<b>2995</b>	<b>481865</b>	9	8	2.0, 2.1, 2.2	
	2.5	3.0	0.2	0	8.5	8.5	-10	140	FDA FKM	<b>131ZH1325</b>	<b>2995</b>	<b>481865</b>	9	8	2.0, 2.1, 2.2	
	3.0	3.7	0.2	0	6	6	-10	140	FDA FKM	<b>131ZH1330</b>	<b>2995</b>	<b>481865</b>	9	8	2.0, 2.1, 2.2	
	1.5	1.4	0.1	0	20	20	-10	140	Ruby	<b>131ZH0315</b>	<b>2995</b>	<b>481865</b>	9	8	2.0, 2.1, 2.2	
	2.0	2.0	0.1	0	14	14	-10	140	Ruby	<b>131ZH0320</b>	<b>2995</b>	<b>481865</b>	9	8	2.0, 2.1, 2.2	
	2.5	3.0	0.2	0	8.5	8.5	-10	140	Ruby	<b>131ZH0325</b>	<b>2995</b>	<b>481865</b>	9	8	2.0, 2.1, 2.2	
	3.0	3.7	0.2	0	6	6	-10	140	Ruby	<b>131ZH0330</b>	<b>2995</b>	<b>481865</b>	9	8	2.0, 2.1, 2.2	
NPT 1/8"	1.5	1.4	0.08	0	20	20	-10	140	FDA FKM	<b>U131ZH1115</b>	<b>2995</b>	<b>481865</b>	9	8	2.0, 2.1, 2.2	5
	2.0	2.0	0.12	0	14	14	-10	140	FDA FKM	<b>U131ZH1120</b>	<b>2995</b>	<b>481865</b>	9	8	2.0, 2.1, 2.2	
	2.5	3.0	0.18	0	8.5	8.5	-10	140	FDA FKM	<b>U131ZH1125</b>	<b>2995</b>	<b>481865</b>	9	8	2.0, 2.1, 2.2	
	3.0	3.7	0.22	0	6	6	-10	140	FDA FKM	<b>U131ZH1130</b>	<b>2995</b>	<b>481865</b>	9	8	2.0, 2.1, 2.2	
	1.5	1.4	0.08	0	20	20	-10	140	Ruby	<b>U131ZH0115</b>	<b>2995</b>	<b>481865</b>	9	8	2.0, 2.1, 2.2	
	2.0	2.0	0.12	0	14	14	-10	140	Ruby	<b>U131ZH0120</b>	<b>2995</b>	<b>481865</b>	9	8	2.0, 2.1, 2.2	
	2.5	3.0	0.18	0	8.5	8.5	-10	140	Ruby	<b>U131ZH0125</b>	<b>2995</b>	<b>481865</b>	9	8	2.0, 2.1, 2.2	
	3.0	3.7	0.22	0	6	6	-10	140	Ruby	<b>U131ZH0130</b>	<b>2995</b>	<b>481865</b>	9	8	2.0, 2.1, 2.2	

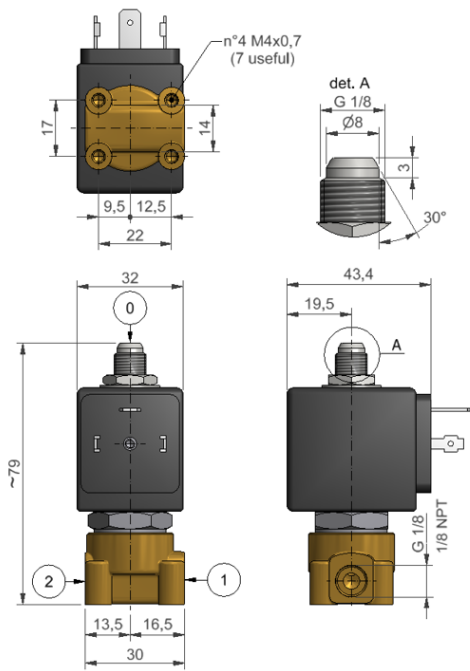

Dimensional drawing N° 5

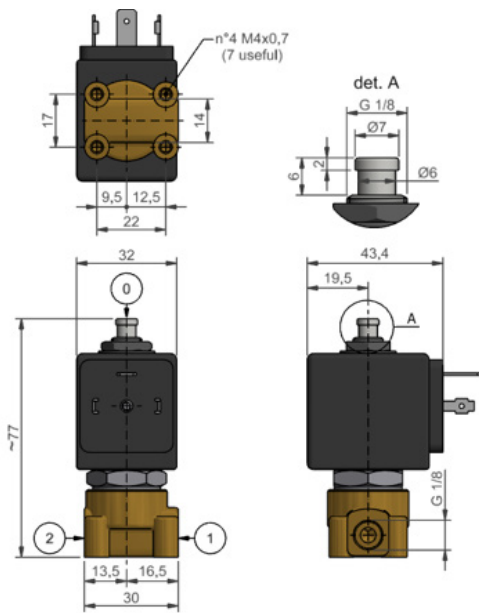

Dimensional drawing N° 6

All dimensions are in mm

# 3/2

## 131KH Series 3 way valves, normally closed



Our Parker range of healthy solenoid valves provides you with top-class performance as a result of the entire stainless steel structure of the valve pilots.

Compact and robust at the same time, the stainless steel nozzle included in all 32mm operated range improves valve life, endurance and resistance to lime-scale build up effect. A wide range of electrical parts can be used with this valve, including IP65 VDE and UL solutions. Typical applications include cold water loading function or hot water-steam on/off control.

**Valve body:** forged brass, CW510L UNI EN 12165

**Seals:** FDA FKM, Ruby

**Sleeve, plungers and nozzle:** stainless steel



### 1/4" Pipe Mounting Connection

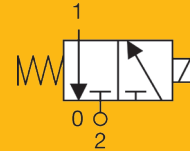

Port Size	Orifice Ø mm	Flow Factors		Operating Pressure Differential			Fluid Temperature		Seat Seal	Parker Valves			Power		Coil Group	Dwg N°
		Kv	KV	Min.	Max. (MOPD)		Min.	Max.		Valve Ref.	Housing Ref.	Coil Ref.	AC	DC		
		l/min	m³/h	Bar	AC bar	DC bar	°C	°C					W	W		
G1/4	1.5	1.4	0.08	0	20	20	-10	140	FDA FKM	131KH1115	2995	481865	9	8	2.0, 2.1, 2.2	7
	2.0	2.0	0.12	0	14	14	-10	140	FDA FKM	131KH1120	2995	481865	9	8	2.0, 2.1, 2.2	
	2.5	3.0	0.18	0	8.5	8.5	-10	140	FDA FKM	131KH1125	2995	481865	9	8	2.0, 2.1, 2.2	
	3.0	3.7	0.22	0	6	6	-10	140	FDA FKM	131KH1130	2995	481865	9	8	2.0, 2.1, 2.2	
	4.0	5.2	0.31	0	3.5	3.5	-10	140	FDA FKM	131KH1140	2995	481865	9	8	2.0, 2.1, 2.2	8
5.0	9.3	0.56	0	2	2	-10	140	FDA FKM	131KH1150	2995	492425	14	14	-		
G1/4	1.5	1.4	0.08	0	20	20	-10	140	Ruby	131KH0115	2995	481865	9	8	2.0, 2.1, 2.2	7
	2.0	2.0	0.12	0	14	14	-10	140	Ruby	131KH0120	2995	481865	9	8	2.0, 2.1, 2.2	
	2.5	3.0	0.18	0	8.5	8.5	-10	140	Ruby	131KH0125	2995	481865	9	8	2.0, 2.1, 2.2	
	3.0	3.7	0.22	0	6	6	-10	140	Ruby	131KH0130	2995	481865	9	8	2.0, 2.1, 2.2	

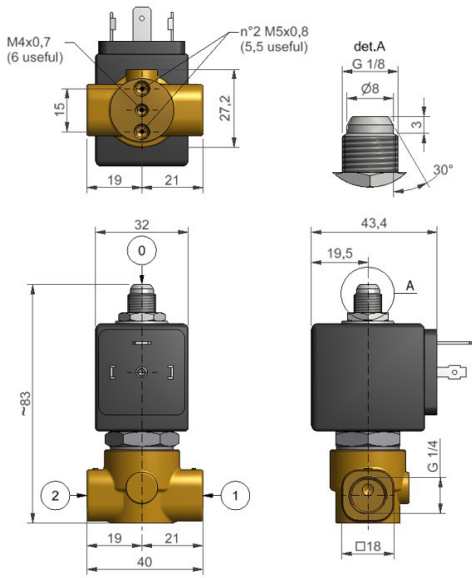

Dimensional drawing N° 7

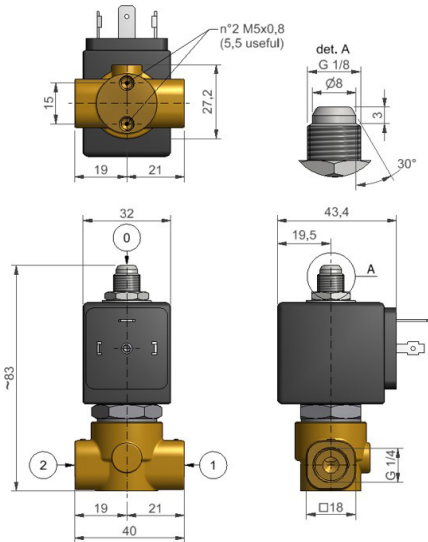

Dimensional drawing N° 8

All dimensions are in mm

# 3/2

## 131FH Series 3 way valves, normally closed



Our Parker range of healthy solenoid valves provides you with top-class performance as a result of the entire stainless steel structure of the valve pilots.

Compact and robust at the same time, the stainless steel nozzle included in all 32mm operated range improves valve life, endurance and resistance to lime-scale build up effect. A wide range of electrical parts can be used with this valve, including IP65 VDE and UL solutions. Typical applications include cold water loading function or hot water-steam on/off control.

**Valve body:** forged brass, CW510L UNI EN 12165

**Seals:** FDA FKM, Ruby

**Sleeve, plungers and nozzle:** stainless steel



### Flanged (SB) Connection

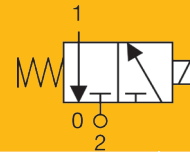

Port Size	Orifice Ø mm	Flow Factors		Operating Pressure Differential			Fluid Temperature		Seat Seal	Parker Valves			Power		Coil Group	Dwg N°
		Kv l/min	KV m³/h	Min. Bar	Max. (MOPD) AC bar	DC bar	Min. °C	Max. °C		Valve Ref.	Housing Ref.	Coil Ref.	AC W	DC W		
SB	1.5	1.3	0.08	0	20	20	-10	140	FDA FKM	131FH1115	2995	481865	9	8	2.0, 2.1, 2.2	9
	2.0	2.0	0.12	0	15	15	-10	140	FDA FKM	131FH1120	2995	481865	9	8	2.0, 2.1, 2.2	
	2.5	2.6	0.16	0	10	10	-10	140	FDA FKM	131FH1125	2995	481865	9	8	2.0, 2.1, 2.2	
	3.0	3.0	0.18	0	7.5	7.5	-10	140	FDA FKM	131FH1130	2995	481865	9	8	2.0, 2.1, 2.2	
	1.5	1.3	0.08	0	20	20	-10	140	Ruby	131FH0115	2995	481865	9	8	2.0, 2.1, 2.2	
	2.0	2.0	0.12	0	15	15	-10	140	Ruby	131FH0120	2995	481865	9	8	2.0, 2.1, 2.2	
	2.5	2.6	0.16	0	10	10	-10	140	Ruby	131FH0125	2995	481865	9	8	2.0, 2.1, 2.2	
	3.0	3.0	0.18	0	7.5	7.5	-10	140	Ruby	131FH0130	2995	481865	9	8	2.0, 2.1, 2.2	
SB	1.5	1.3	0.08	0	20	20	-10	140	FDA FKM	131FH1315	2995	481865	9	8	2.0, 2.1, 2.2	10
	2.0	2.0	0.12	0	15	15	-10	140	FDA FKM	131FH1320	2995	481865	9	8	2.0, 2.1, 2.2	
	2.5	2.6	0.16	0	10	10	-10	140	FDA FKM	131FH1325	2995	481865	9	8	2.0, 2.1, 2.2	
	3.0	3.0	0.18	0	7.5	7.5	-10	140	FDA FKM	131FH1330	2995	481865	9	8	2.0, 2.1, 2.2	
	1.5	1.3	0.08	0	20	20	-10	140	Ruby	131FH0315	2995	481865	9	8	2.0, 2.1, 2.2	
	2.0	2.0	0.12	0	15	15	-10	140	Ruby	131FH0320	2995	481865	9	8	2.0, 2.1, 2.2	
	2.5	2.5	0.16	0	10	10	-10	140	Ruby	131FH0325	2995	481865	9	8	2.0, 2.1, 2.2	
	3.0	3.0	0.18	0	7.5	7.5	-10	140	Ruby	131FH0330	2995	481865	9	8	2.0, 2.1, 2.2	

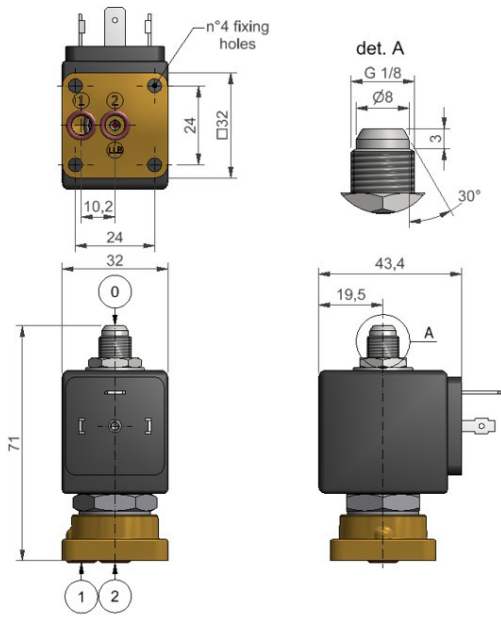

Dimensional drawing N° 9

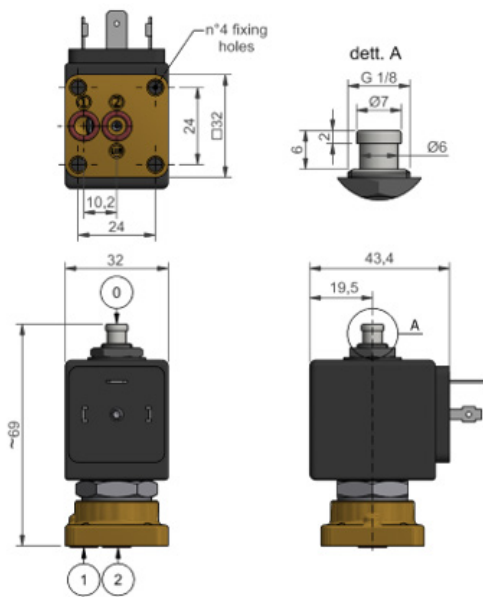

Dimensional drawing N° 10

All dimensions are in mm

# 2/2

## 121KH Series with manual flow regulator 2 way valves, normally closed



121KH series provides superior performance, resulting from the entire stainless steel structure of the valve pilots. The structure of the manual regulator is made by stainless steel, which improves reliability and offers a repetitive precision in calibration also after many regulations. A wide range of electrical parts might be used with this valve, including IP65 VDE and UL solutions.

**Fluids:** cold and hot water, within the media temperature limits

**Valve body:** forged brass, CW510L UNI EN 12165

**Seals:** FDA FKM

**Sleeve and plungers:** stainless steel

**Regulation screw to adjust flow rate:** stainless steel



### 1/8" Pipe Mounting Connection Manual calibration of the flow rate

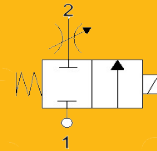

Port Size	Orifice Ø	Flow Factors		Operating Pressure Differential			Fluid Max. Temp. C°	Seat Seal	Parker Valves			Power		Dwg N°
		l/m	m³/h	Min. Bar	Max. (MOPD)				Valve Ref.	Housing Ref.	Coil Ref.	DC	AC	
G1/8	1.5	0.83	0.05	0	15	15	140	FDA FKM	121KH1465	2995	481865	9	8	11

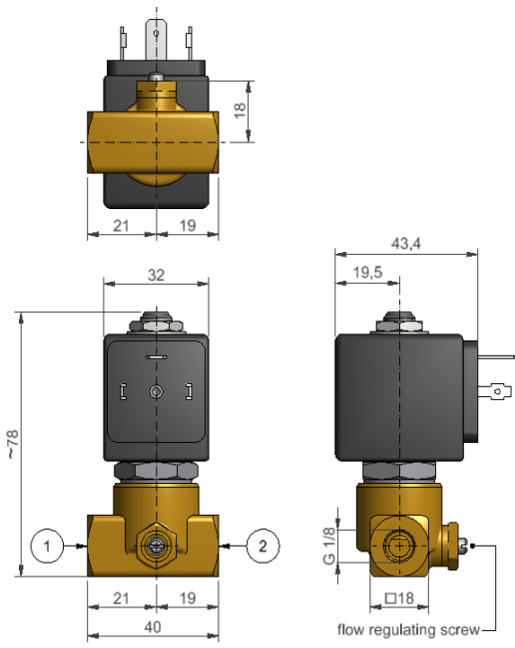

Dimensional drawing N° 11

All dimensions are in mm

# 2/2

## 121WH Series - Compact 2 way valves, normally closed



121WH series is a small, compact and flexible 2/2 solution, with a robust stainless steel operator. 1/8" ports and wide range of valve orifices are available. IP65 electrical parts as well as UL/CSA recognized electrical parts may be used with this valve.

Typical applications: cold water, hot water and steam on/off control.

**Fluids:** cold and hot water, within the media temperature limits

**Valve body:** forged brass, CW510L UNI EN 12165

**Seals:** FDA FKM

**Sleeve, plungers:** stainless steel



### 1/8" Pipe Mounting Connection

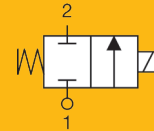

Port Size	Orifice Ø	Flow Factors		Operating Pressure Differential			Fluid Temperature		Seat Seal	Parker Valves			Power		Coil Group	Dwg N°
		Kv l/min	KV m³/h	Min. Bar	Max. (MOPD)		Min. °C	Max. °C		Valve Ref.	Housing Ref.	Coil Ref.	AC W	DC W		
					AC bar	DC bar										
G1/8	1.0	0.5	0.03	0	20	20	-10	140	FDA FKM	121WH1010	8993	481180	4	5	1.1, 1.3	12
	1.2	0.7	0.04	0	20	12	-10	140	FDA FKM	121WH1012	8993	481180	4	5	1.1, 1.3	
	1.5	1	0.06	0	20	10	-10	140	FDA FKM	121WH1015	8993	481180	4	5	1.1, 1.3	
	1.8	0.9	0.05	0	19	7.5	-10	140	FDA FKM	121WH1018	8993	481180	4	5	1.1, 1.3	
	2.0	1.8	0.11	0	15	7	-10	140	FDA FKM	121WH1020	8993	481180	4	5	1.1, 1.3	
	2.5	2.3	0.14	0	10	4	-10	140	FDA FKM	121WH1025	8993	481180	4	5	1.1, 1.3	

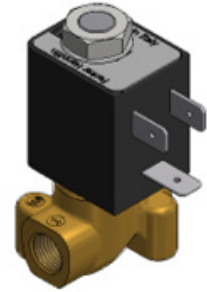
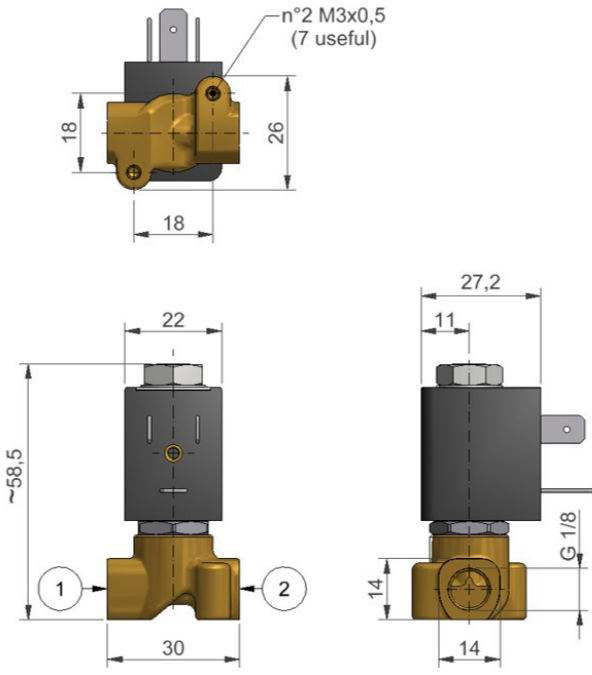

Dimensional drawing N° 12

All dimensions are in mm

# 3/2

## 131WH Series - Compact 3 way valves, normally closed



131WH series is a small, compact and flexible 3/2 solution, with a robust stainless steel operator. 1/8" ports and wide range of valve orifices are available. IP65 electrical parts as well as UL/CSA recognized electrical parts may be used with this valve.

Typical application: cold water, hot water and steam on/off control.

**Fluids:** cold and hot water, within the media temperature limits

**Valve body:** forged brass, CW510L UNI EN 12165

**Seals:** FDA FKM

**Sleeve, plungers:** stainless steel



### 1/8" Pipe Mounting Connection

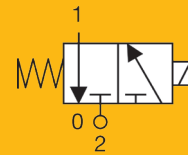

Port Size	Orifice Ø	Flow Factors		Operating Pressure Differential			Fluid Temperature		Seat Seal	Parker Valves			Power		Coil Group	Dwg N°
		Kv	KV	Min.	Max. (MOPD)		Min.	Max.		Valve Ref.	Housing Ref.	Coil Ref.	AC	DC		
		mm	l/min	m³/h	Bar	AC bar	DC bar	°C					°C	W		
G1/8	1.0	0.5	0.03	0	15	15	-10	140	FDA FKM	<b>131WH1410</b>	<b>8993</b>	<b>481180</b>	4	5	1.1, 1.3*	13
	1.2	0.7	0.04	0	14	14	-10	140	FDA FKM	<b>131WH1412</b>	<b>8993</b>	<b>481180</b>	4	5	1.1, 1.3*	
	1.5	1.0	0.06	0	8	8	-10	140	FDA FKM	<b>131WH1415</b>	<b>8993</b>	<b>481180</b>	4	5	1.1, 1.3*	
	1.8	1.2	0.07	0	6	6	-10	140	FDA FKM	<b>131WH1418</b>	<b>8993</b>	<b>481180</b>	4	5	1.1, 1.3*	
	2.0	1.5	0.09	0	5	5	-10	140	FDA FKM	<b>131WH1420</b>	<b>8993</b>	<b>481180</b>	4	5	1.1, 1.3*	
	2.5	2.3	0.14	0	3	3	-10	140	FDA FKM	<b>131WH1425</b>	<b>8993</b>	<b>481180</b>	4	5	1.1, 1.3*	
G1/8	1.0	0.5	0.03	0	15	15	-10	140	FDA FKM	<b>131WH1510</b>	<b>8993</b>	<b>481180</b>	4	5	1.1, 1.3*	14
	1.2	0.7	0.04	0	14	14	-10	140	FDA FKM	<b>131WH1512</b>	<b>8993</b>	<b>481180</b>	4	5	1.1, 1.3*	
	1.5	1.0	0.06	0	8	8	-10	140	FDA FKM	<b>131WH1515</b>	<b>8993</b>	<b>481180</b>	4	5	1.1, 1.3*	
	1.8	1.2	0.07	0	6	6	-10	140	FDA FKM	<b>131WH1518</b>	<b>8993</b>	<b>481180</b>	4	5	1.1, 1.3*	
	2.0	1.5	0.09	0	5	5	-10	140	FDA FKM	<b>131WH1520</b>	<b>8993</b>	<b>481180</b>	4	5	1.1, 1.3*	
	2.5	2.3	0.14	0	3	3	-10	140	FDA FKM	<b>131WH1525</b>	<b>8993</b>	<b>481180</b>	4	5	1.1, 1.3*	

\* 1.3 Coil group solution applicable in AC voltages only

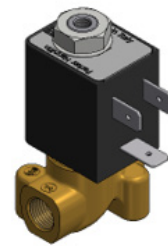
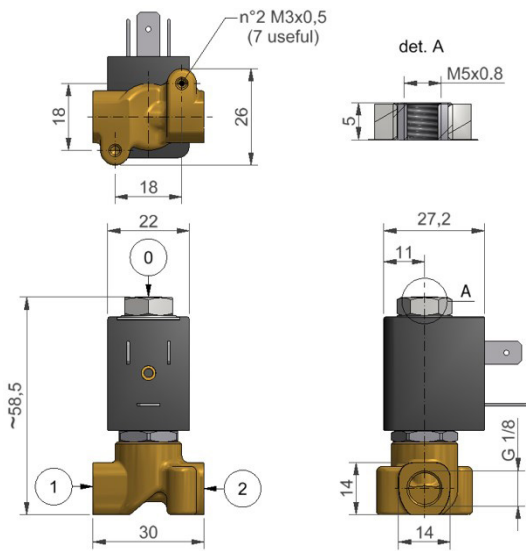

Dimensional drawing N° 13

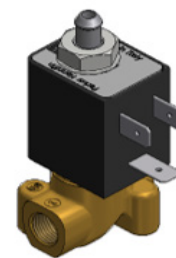
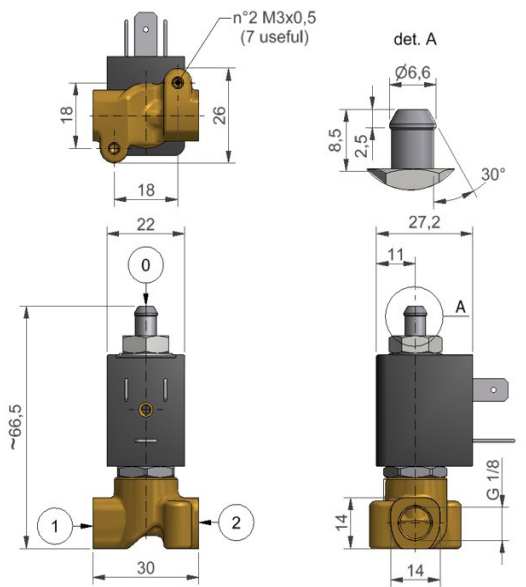

Dimensional drawing N° 14

All dimensions are in mm

# Housing

## Housing for 22 mm coil

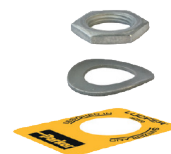

Composed of a nameplate with the details of the valve type, a washer and a nut to secure the 22 mm coil to the valve.

Reference	Specification	Application
8993	Standard - aluminium nameplate - passivated washer and nut - pressure indication in [bar]	Compact valves 121WH/131WH Series

## Housing for 32 mm coil



Composed of a nameplate giving details of the valve type, a round washer and a nut to ensure the fixing between 32 mm coil and the valve.

Reference	Specification	Application
2995	Standard - aluminium nameplate - passivated iron washer and nut - pressure indication in [bar]	ZH, FH and KH valve families

**COIL GROUP**  
**2.0/2.1**

# Electrical parts

481865/483510 Series



These coils can be mounted with every Parker solenoid valves corresponding to the specified coil group. See column "Coil Group" valve pages.

This is an encapsulated assembly comprising a coil, integral magnetic iron path and snap-on plug connection.

The synthetic material encapsulation provides an effective compact housing, offering full protection against dust, oil, water, etc.

Ease of mounting in confined space - offers shock and corrosion protection - simplifies conversion of existing equipment to other requirements, etc. Coils conform to the IEC/CENELEC safety standards and complies with European low-voltage directive 2014/35/EU.



Specification		Standard			Double frequency		
Reference (without DIN plug)		481865			483510		
Coil group		2.0 / 2.1					
Degree of protection		IP65 according to IEC / EN 60529 standards (with DIN plug)					
Class of insulation		F 155°C					
Electrical connection		The coil is connected with a 2 P + E plug according to EN 175301-803 type A					
Ambient temperature		-40°C to +50°C The application is limited also by the temperature range of the valve					
Elect. Power	DC	Pn (hot)	9 W		-		
		P (cold) 20°C	12 W		-		
	AC	Pn (holding)	8 W		9 W		
		Attraction cold	26 VA (9 W)		32 VA (10 W)		
Weight		130 g (without plug)					
Voltages "Un"		VAC/Hz	Code	VDC	Code	VAC/Hz	Code
-10% to +10% of the Un		24/50	A2	24	C2	24/50, 24/60	P0
		110/50	A5			110-115/50, 120/60	S5
		220-230/50	3D			220-240/50, 240/60	S6

To order a coil choose Coil Ref + Voltage Code, example: 481865 for 24 VDC = **481865C2**

These coils must be used with suitable housing 2995.

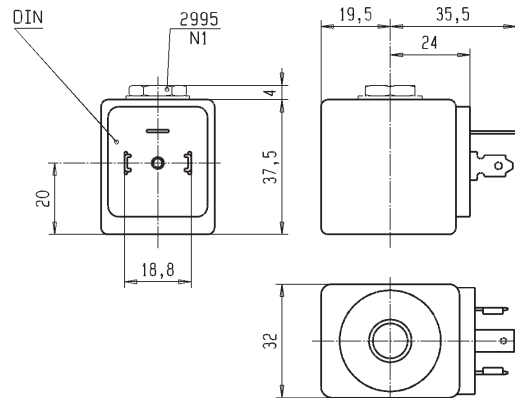

**COIL GROUP**  
**2.0/2.1**



491514 Series - UL recognized

These coils can be mounted with every Parker solenoid valves corresponding to the specified Coil Group. See column "Coil Group" valve pages.

This is an encapsulated assembly comprising a coil, integral magnetic iron path and snap-on plug connection.

The synthetic material encapsulation provides an effective compact housing, offering full protection against dust, oil, water, etc.

Ease of mounting in confined space - offers shock and corrosion protection - simplifies conversion of existing equipment to other requirements, etc.

Coils conform to the IEC/CENELEC safety standards and complies with European low-voltage directive 2014/35/EU.

DIN plug connector to be ordered separately (see coil accessories section).



Specification		UL-recognized coil - UL File E200N - designation AMIF			
Ref. (without DIN plug)		491514			
Coil group		2.0 / 2.1			
Degree of protection		IP65 according to IEC / EN 60529 standards (with DIN plug)			
Class of insulation		F 155°C			
Electrical connection		The coil is connected with a 2 P + E plug according to EN 175301-803 type A			
Ambient temperature		-40°C to +50°C The application is limited also by the temperature range of the valve			
Elect. Power	DC	Pn (hot)	-	12 W	
		P (cold) 20°C	-	16 W	
	AC	Pn (holding)	11 W	-	
		Attraction cold	40 VA (13 W)	-	
Weight		130 g (without plug)			
Voltages "Un"		VAC/Hz	Code	VDC	Code
- 15% to +10% of the Un		110/50-120/60 220/50-240/60	P3 Q3	24	C

To order a coil choose Coil Ref + Voltage Code, example: 491514 for 24 VDC = **491514C2**

These coils must be used with suitable housing 2995.

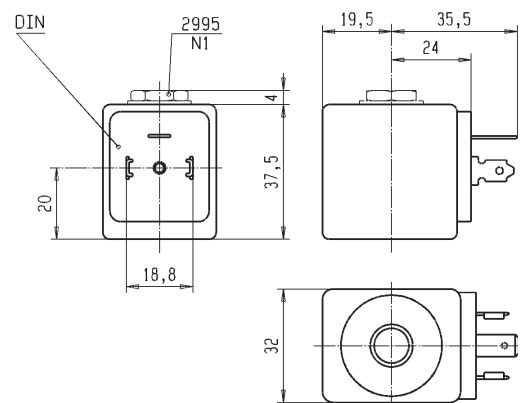

**COIL GROUP**  
**2.0/2.1**



**492453/492425 Series - High Temperature**

These coils can be mounted with every Parker solenoid valves corresponding to the specified Coil Group. See column "Coil Group" valve pages.

This is an encapsulated assembly comprising a coil, integral magnetic iron path and snap-on plug connection.

The synthetic material encapsulation provides an effective compact housing, offering full protection against dust, oil, water, etc.

Ease of mounting in confined space - offers shock and corrosion protection - simplifies conversion of existing equipment to other requirements, etc.

Coils conform to the IEC/CENELEC safety standards and complies with European low-voltage directive 2014/35/EU.



Specification		High temperature			High temp. + high power				
Reference (without DIN plug)		492453			492425				
Coil Group		2.0 / 2.1			2.0 / 2.2				
Degree of protection		IP65 according to IEC / EN 60529 standards (with DIN plug)							
Class of insulation		H 180°C							
Electrical connection		The coil is connected with a 2 P + E plug according to EN 175301-803 type A							
Ambient temperature		-40°C to +50°C The application is limited also by the temperature range of the valve							
Elect. Power	DC	Pn (hot)	9 W			14 W			
		P (cold) 20°C	12 W			21 W			
	AC	Pn (holding)	8 W			14 W			
		Attraction cold	26 VA (9 W)			55 VA (18 W)			
Weight		130 g (without plug)							
Voltages "Un"		VAC/Hz	Code	VDC	Code	VAC/Hz	Code	VDC	Code
-10% to +10% of the Un		24/50	A2	24	C2	24/50	A2	24	C2
		110/50	A5			110/50	A5		
		220/50-230/50	3D			230/50	F4		

To order a coil choose Coil Ref + Voltage Code, example: 492453 for 24 VDC = **492453C2**

These coils must be used with suitable housing 2995.

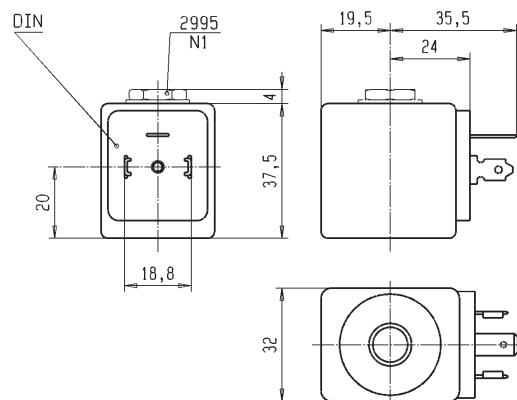

# COIL GROUP

## 1.1

### 481180 Series



These coils can be mounted with every Parker solenoid valves corresponding to the specified Coil Group. See column "Coil Group" valve pages.

This coil is designed for valves equipped with a miniature tube assembly (2000 series valves). This is an encapsulated assembly comprising a coil, integral magnetic iron path and snap-on plug connection.

The synthetic material encapsulation provides an effective compact housing, offering full protection against dust, oil, water, etc.

Ease of mounting in confined space - offers shock and corrosion protection - simplifies conversion of existing equipment to other requirements, etc.

Coils conform to the IEC/CENELEC safety standards and complies with European low-voltage directive 2014/35/EU.



Specification		Standard			
Reference (without DIN plug)		481180			
Coil group		1.1			
Degree of protection		IP65 according to IEC / EN 60529 standards (with DIN plug)			
Class of insulation		F 155°C			
Electrical connection		The coil is connected with a 2 P + E plug according to EN 175301-803 type A			
Ambient temperature		-40°C to +50°C The application is limited also by the temperature range of the valve			
Elect. Power	DC	Pn (hot)	5 W		
		P (cold) 20°C	6.5 W		
	AC	Pn (holding)	4 W		
		Attraction cold	8.9 VA (5W)		
Weight		100 g (with plug)			
Voltages "Un"		VAC/Hz	Code	VDC	Code
- 15% to +10% of the Un		24/50 110/50-115/50 220/50-230/50	A2 0A 3D	24	C2

To order a coil choose Coil Ref + Voltage Code, example: C2 for 24 VDC = **481180C2**

These coils must be used with suitable housing 8993.

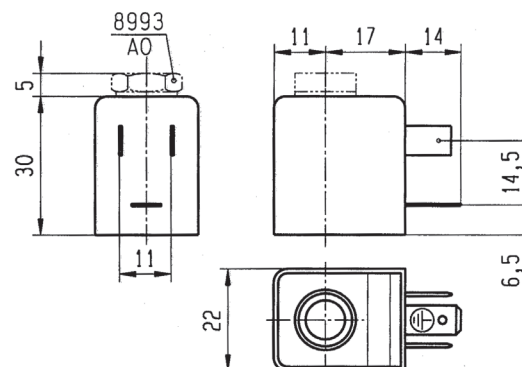

## COIL GROUP

### 1.3



## WB Series - UL Recognized

These coils can be mounted with every Parker solenoid valves corresponding to the specified Coil Group. See column "Coil Group" valve pages.

Coil manufactured with H class copper wire, moulded in thermoplastic material polyester with 30% glass fiber. IP65 protection rate with EN 175301-803 - Type A three pin connector and appropriate gasket.

The synthetic material encapsulation provides an effective compact housing, offering full protection against dust, oil, water, etc.

Coils conform to the IEC/CENELEC safety standards and complies with European low-voltage directive 2014/35/EU.

For UL recognized version: UL file MH19410

DIN plug connector to be ordered separately (see coil accessories section).



Specification		Standard	UL recognized version
Reference (without DIN plug)		WB4.5 for AC WB5.0 for DC	WB4.5 cURus WB5.0 cURus
Coil Group		1.3	
Degree of protection		IP65 according to IEC / EN 60529 standards (with DIN plug + gasket)	
Class of insulation		F 155°C	F 155°C
Electrical connection		The coil is connected with a 2 P + E plug according to EN 175301-803 type B	
Ambient temperature		-10°C to +50°C The application is limited also by the temperature range of the valve.	
Elect. Power	DC	P (cold) 20°C	5 W
	AC	Pn (holding)	4.5 W
		Attraction cold	7.5 VA
Weight		90 g (without plug)	
Voltages "Un"		WB4.5 VAC/Hz	WB4.5 UR VAC/Hz
-10% to +10% of Un for AC - 5 % to + 10 % for Un DC		24/50-60	115/60
		115/50-60 230/50-60	208-240/60 24/60
			WB5.0 cURus VDC
			24 VDC

This coil does not require housings if ordered together with the valve.

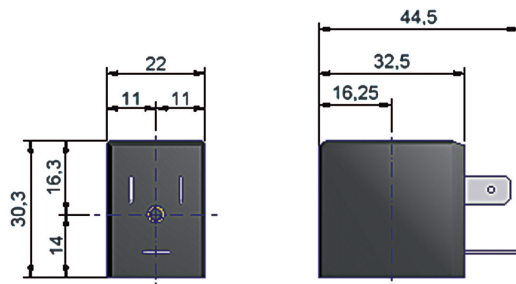

# Accessories

## Coil accessories

### DIN PLUG CONNECTOR ACCORDING TO EN 175301-803 - B

Part number No. 600040

Max A: 16 A  
 Cable section: 6 - 8 mm<sup>2</sup>  
 Nominal voltage: 250-/300 V=  
 Dimensional drawing N°15



### DIN PLUG CONNECTOR ACCORDING TO EN 175301-803 - A

Part number No. 600003PLUG

Max A: 16A  
 Cable section: 6-10mm<sup>2</sup>  
 Nominal voltage: 250-/300 V =  
 Dimensional drawing N°16

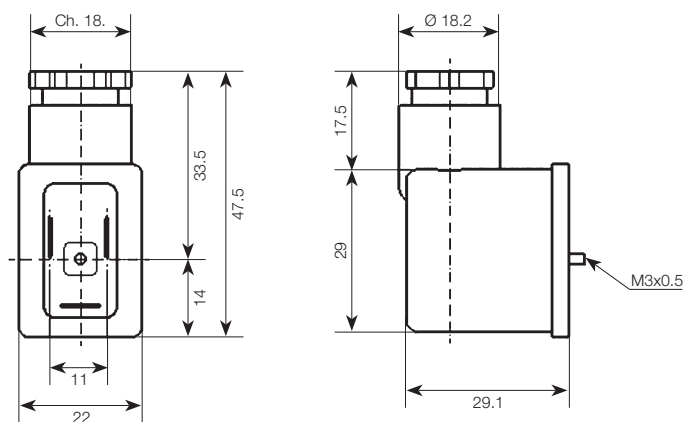

Dimensional drawing N° 15

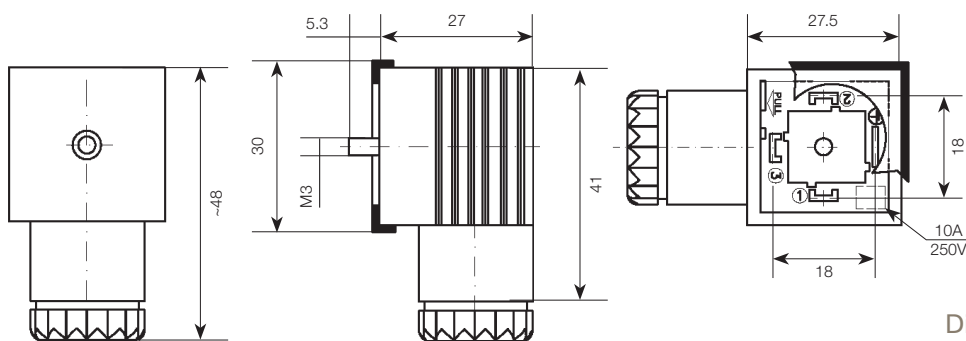

Dimensional drawing N° 16

All dimensions are in mm

# How to order

To order a complete solenoid valve, please select the 3 elements following the procedure below.

## Step 1

Select the pressure vessel reference needed on pages 8-24.

Seat Seal	Parker Valves		
	Valve Ref.	Housing Ref.	Coil Ref.
FDA FKM	<b>121ZH1015</b>	2995	481865
FDA FKM	121ZH1020	2995	481865
FDA FKM	121ZH1025	2995	481865

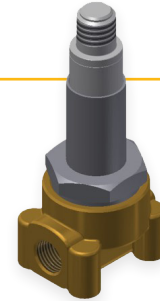

## Step 2

Select housing on page 26.

## Step 3

Select coil on page 27.

Note: WB coil series does not require housing if ordered together with the valve.

Specification	Standard
Reference (without DIN plug)	<b>481865</b>



## Step 4

Select accessories on page 32.

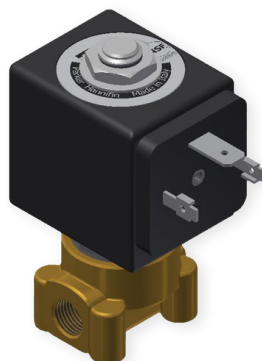

Complete valve example:

**121ZH1015-2995-481865C2**

### Ordering a product or a configuration not listed in the catalogue.

When an application demands a combination of features not listed in the catalogue, please feel free to contact the closest Parker office. Parker personnel will assist you in determining the applicability availability and price of the new product.

Parker Hannifin Corporation  
**Fluid & Climate Controls Europe**  
Via Enrico Fermi 5  
20060 Gessate (MI) Italy  
[www.parker.com](http://www.parker.com)

Catalogue 5112/UK 11/2024  
Your Local Authorized Parker Distributor

© 2024 Parker Hannifin Corporation

