



aerospace  
climate control  
electromechanical  
filtration  
fluid & gas handling  
hydraulics  
**pneumatics**  
process control  
sealing & shielding



# Pneumatic Cylinders

Ø160 to Ø320 mm  
According to ISO 15552

Catalogue PDE2667TCEN



ENGINEERING YOUR SUCCESS.



**Important**

Before attempting any external or internal work on the cylinder or any connected components, make sure the cylinder is vented and disconnect the air supply in order to ensure isolation of the air supply.



**Note**

All technical data in this catalogue are typical data only.  
Air quality is essential for maximum cylinder service life (see ISO 8573).



**WARNING**

**FAILURE OR IMPROPER SELECTION OR IMPROPER USE OF THE PRODUCTS AND/OR SYSTEMS DESCRIBED HEREIN OR RELATED ITEMS CAN CAUSE DEATH, PERSONAL INJURY AND PROPERTY DAMAGE.**

This document and other information from Parker Hannifin Corporation, its subsidiaries and authorized distributors provide product and/or system options for further investigation by users having technical expertise. It is important that you analyze all aspects of your application and review the information concerning the product or system in the current product catalog. Due to the variety of operating conditions and applications for these products or systems, the user, through its own analysis and testing, is solely responsible for making the final selection of the products and systems and assuring that all performance, safety and warning requirements of the application are met. The products described herein, including without limitation, product features, specifications, designs, availability and pricing, are subject to change by Parker Hannifin Corporation and its subsidiaries at any time without notice.

**SALE CONDITIONS**

The items described in this document are available for sale by Parker Hannifin Corporation, its subsidiaries or its authorized distributors. Any sale contract entered into by Parker will be governed by the provisions stated in Parker's standard terms and conditions of sale (copy available upon request).

<b>Contents</b>	<b>page</b>
Product overview .....	4
General technical data .....	5-7
Cylinder size and selection guide .....	8-9
Cylinder dimensions .....	10
Order key code - Cylinder .....	11
Order code - Mountings.....	11
Mounting dimensions .....	12-16
Sensors.....	17-19
Cylinder seal kits.....	20-21
Air quality specification .....	22

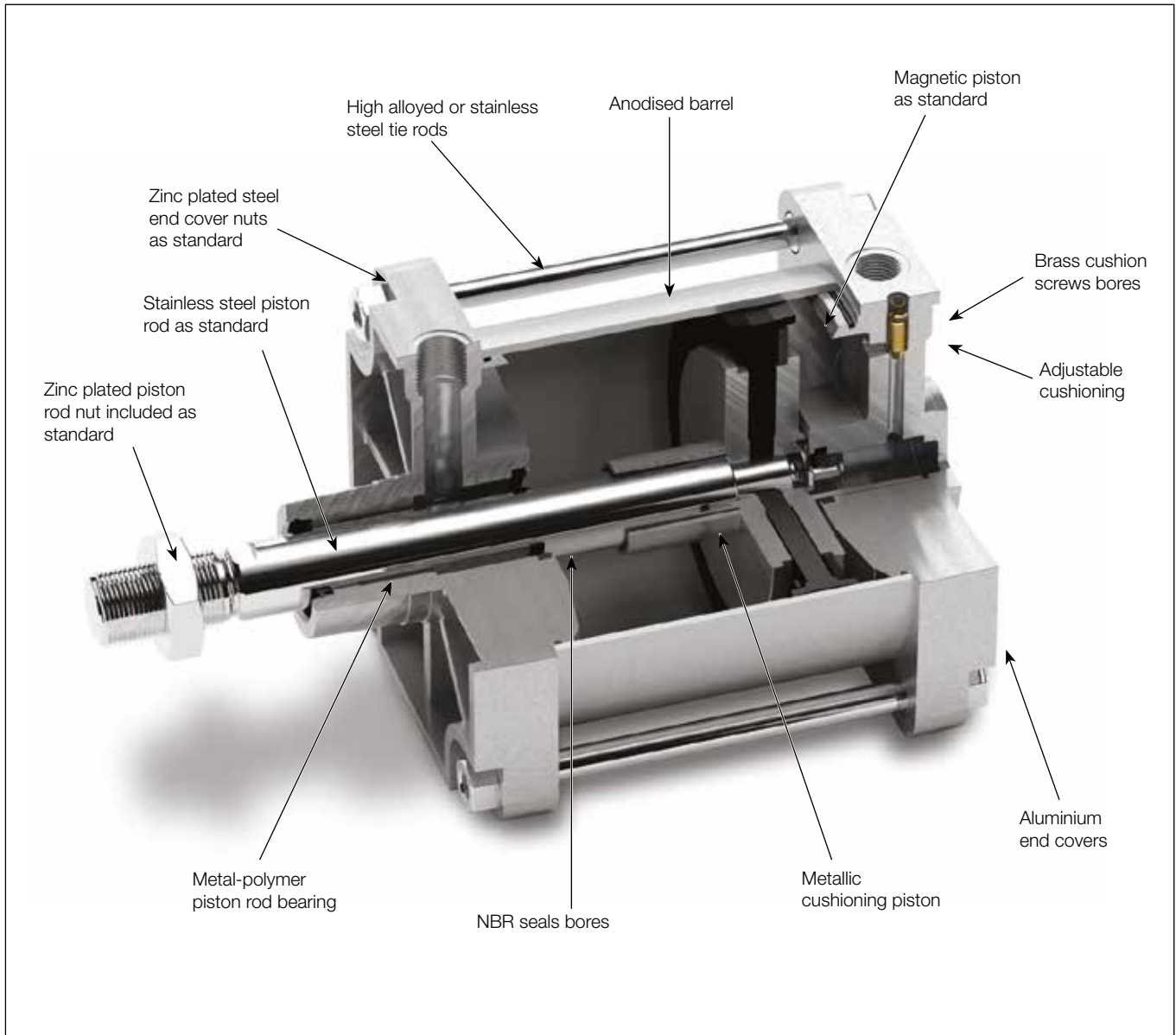

## Standard cylinders P1D-T, ISO 15552 bores Ø160 - Ø320 mm

### Global product range

The P1D-T range of cylinders is intended for use in a wide range of applications.

Careful design and high quality manufacture throughout ensure long service life and optimum economy.

Mounting dimensions fully in accordance with ISO 15552 greatly simplifies installation and world-wide interchangeability.

### Features

- Bore sizes Ø160 - Ø320 mm
- Stroke lengths 10 - 2000 mm.
- Stainless steel piston rod as a standard
- Magnetic piston as standard
- Adjustable cushioning as standard
- Special versions on request
- ATEX version as an option (Ø160 - Ø200 mm)

## Technical Data

### Cylinder forces

Bore/ piston rod [mm]	Stroke	Surface area [cm <sup>2</sup> ]	Max theoretical force in N (under different pressure bar)									
			1	2	3	4	5	6	7	8	9	10
160/40	+	201.1	2011	4021	6032	8042	10053	<b>12064</b>	14074	16085	18096	20106
	-	188.5	1885	3770	5655	7540	9425	<b>11310</b>	13195	15080	16965	18850
200/40	+	314.2	3142	6283	9425	12566	15708	<b>18850</b>	21991	25133	28274	31416
	-	301.6	3016	6032	9048	12064	15080	<b>18096</b>	21112	24127	27143	30159
250/50	+	490.9	4909	9818	14726	19635	24544	<b>29453</b>	34361	39270	44179	49088
	-	471.2	4712	9425	14137	18850	23562	<b>28274</b>	32987	37699	42412	47124
320/63	+	804.2	8042	16085	24127	32170	40212	<b>48255</b>	56297	64340	72382	80425
	-	773.1	7731	15462	23192	30923	38654	<b>46385</b>	54115	61846	69577	77308

+ = outward stroke  
- = return stroke

### Cylinder air consumption

Bore/ piston rod [mm]	Stroke	Surface area [cm <sup>2</sup> ]	Air Consumption in l/mn (under different pressure bar)									
			1	2	3	4	5	6	7	8	9	10
160/40	+	201.1	0.400	0.598	0.797	0.995	1.193	<b>1.392</b>	1.590	1.789	1.987	2.186
	-	188.5	0.375	0.561	0.747	0.933	1.119	<b>1.305</b>	1.491	1.677	1.863	2.049
200/40	+	314.2	0.624	0.934	1.245	1.555	1.865	<b>2.175</b>	2.485	2.795	3.105	3.415
	-	301.6	0.599	0.897	1.195	1.492	1.790	<b>2.088</b>	2.386	2.683	2.981	3.279
250/50	+	490.9	0.975	1.460	1.945	2.429	2.914	<b>3.398</b>	3.883	4.367	4.852	5.337
	-	471.2	0.936	1.402	1.867	2.332	2.797	<b>3.262</b>	3.728	4.193	4.658	5.123
320/63	+	804.2	1.598	2.392	3.186	3.980	4.774	<b>5.568</b>	6.362	7.156	7.950	8.744
	-	773.1	1.536	2.299	3.063	3.826	4.589	<b>5.352</b>	6.115	6.878	7.641	8.405

+ extending,  
- retracting

free air consumption for 1 cycle, 10 mm inward and 10 mm outward

### Weight

Cyl.- bore [mm]	P1D-T		Moving parts	
	Base 0 mm [kg]	per 100 mm [kg]	Base 0 mm [kg]	per 100 mm [kg]
Ø160	10.45	2.05	9.69	2.797
Ø200	17.8	2.2	13.73	4.529
Ø250	31	4	22.71	7.586
Ø320	60	6	39.23	13.936

## Pneumatic Cylinders ISO 15552

### General technical data

Product type	Standard cylinder according to ISO 15552
Bore size	160 - 320 mm
Stroke length	10 - 2000 mm
Versions	Double acting
Cushioning	Adjustable air cushioning
Position sensing	Proximity sensor in temperature range -25°C to +80°C
Installation	P1D cylinder and piston rod mountings
Mounting position	Any

### Operating and environmental data

Operating medium:  
For best possible service life and trouble-free operation dry, filtered compressed air to ISO 8573-1:2010 quality class 3.4.3 should be used. This specifies a dew point of +3°C for indoor operation (a lower dew point should be selected for outdoor operation) and is in line with the air quality from most standard compressors with a standard filter.

Operating pressure	1,0 bar to 10 bar
Standard temperature	-20°C to +80°C
High temperature	-10°C to +150°C
Pre-lubricated	Further lubrication is normally not necessary. If additional lubrication is introduced it must be continued.
Corrosion resistance	Resistance to corrosion and chemicals. Materials and surface treatment have been selected for industrial applications where solvents and detergents are frequently used.

### Material specification - bores Ø 160, Ø 200 mm

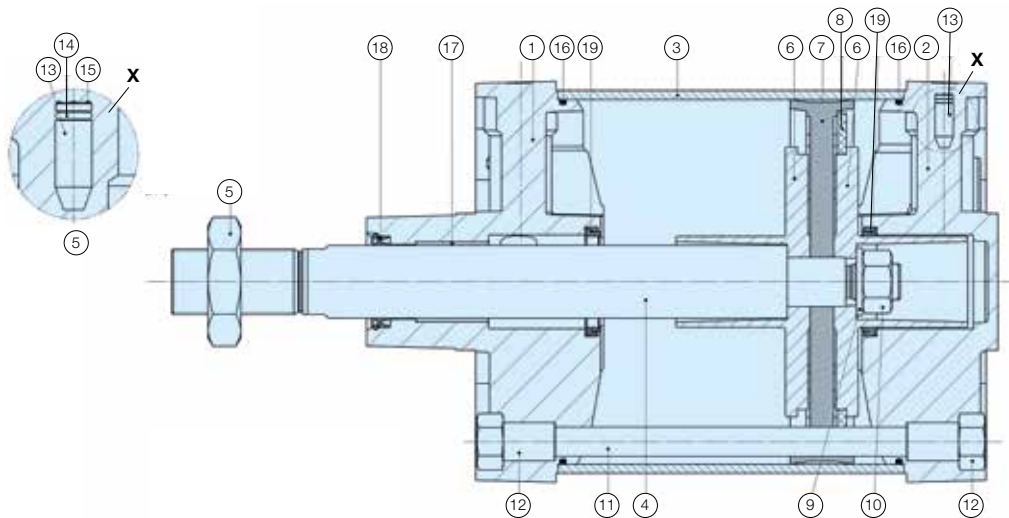

Pos	Part	Specification
1	Front cover	Aluminium
2	Rear cover	Aluminium
3	Cylinder barrel	Anodised aluminium
4	Piston rod	Standard Stainless steel 1.4104 (X12CrMoS17) Option Chrome plated steel 1.5217 (20MnV6)
5	Piston rod nut	Zinc plated steel
6	Cushioning sleeve	Aluminium
7	Piston seal	Standard NBR I option FKM
8	Magnet	Magnet foil
9	Washer	Zinc plated steel
10	Piston nut	Zinc plated steel
11	Tie rod	High alloyed steel 1.4104 (X12CrMoS17)
12	Tie rod nut	Zinc plated steel
13	Cushioning screw	Brass
14	Cushioning O ring	Standard NBR I option FKM
15	Retaining clip	Spring steel
16	O ring	Standard NBR I option FKM
17	Rod bearing	Metal-polymer material
18	Rod seal	Standard NBR I option FKM + PTFE + Bronze
19	Cushion seal	Standard NBR I option FKM

# Pneumatic Cylinders ISO 15552

## Material specification - bores Ø250, Ø 320 mm

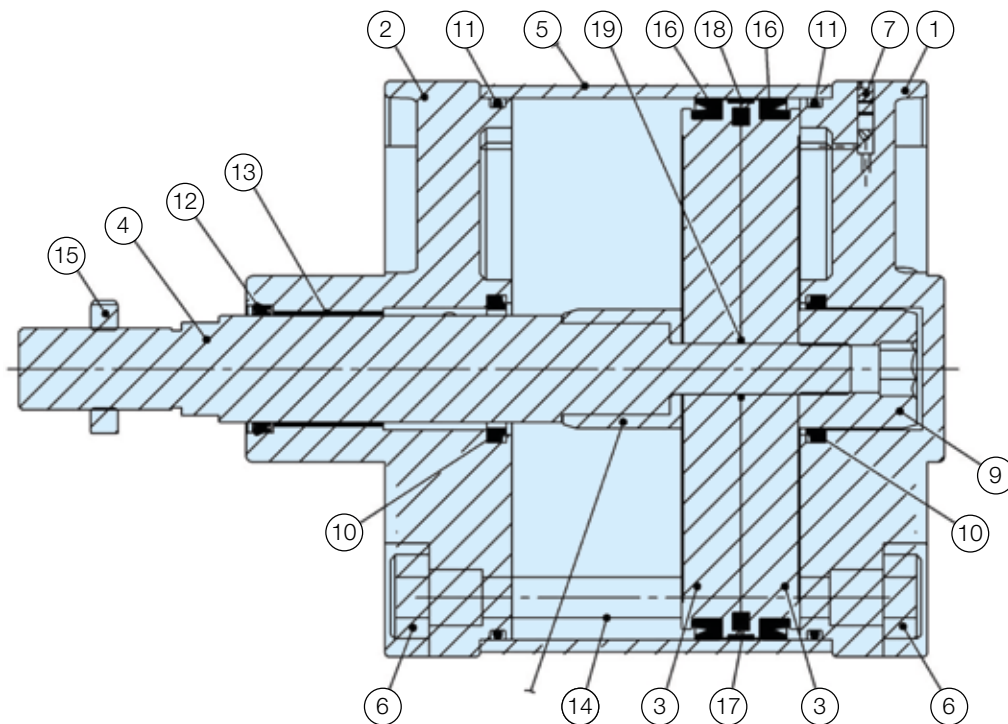

Pos.	Part	Specification	
1	Rear cover	Aluminium	
2	Front cover	Aluminium	
3	Piston	Aluminium	
4	Piston rod	Standard	Stainless steel 1.4021 (X20Cr13)
		Option	Chrome plated steel 1.5217 (20MnV6)
5	Cylinder barrel	Anodised aluminium	
6	Tie rod nut	Zinc plated steel	
7	Cushioning screw	Brass + stainless steel	
8	Cushioning tube	Anodised aluminium	
9	Cushioning female thread	Anodised aluminium	
10	Cushioning seal	Standard	PU
		Option	FKM
11	O-ring	Standard	NBR
		Option	FKM
12	Rod seal	Standard	PU + HYTREL
		Option	FKM + PTFE + Bronze
13	Rod bearing	Metal + Polymer composite (CBS-40)	
14	Tie rod	Stainless steel, 1.4301 (X5CrNi18-10)	
15	Piston rod nut	Zinc plated steel	
16	Piston seals	Standard	PU
		Option	FKM
17	Magnet	Plasto - Ferrite	
18	Piston bearing	Polyacetal	
19	Piston O-Ring	Standard	NBR
		Option	FKM

**Guide for selecting suitable tubing**

The selection of the correct size of tubing is often based on experience, with no great thought to optimising energy efficiency and cylinder velocity. This is usually acceptable, but making a rough calculation can result in worthwhile economic gains.

**The following is the basic principle:**

1. The primary line to the working valve could be oversized (this does not cause any extra air consumption and consequently does not create any extra costs in operation).
2. The tubes between the valve and the cylinder should, however, be optimised according to the principle that an insufficient bore throttles the flow and thus limits the cylinder speed, while an oversized pipe creates a dead volume which increases the air consumption and filling time.

**The following prerequisites apply**

The cylinder load should be about 50 % of the theoretical force (= normal load). A lower load gives a higher velocity and vice versa. The tube size is selected as a function of the cylinder bore, the desired cylinder velocity and the tube length between the valve and the cylinder. If you want to use the capacity of the valve to its maximum, and obtain maximum speed, the tubing should be chosen so that they at least correspond with the equivalent restriction diameter (see description below), so that the tubing does not restrict the total flow. This means that a short tubing must have at least the equivalent restriction diameter. If the tubing is longer, choose it from the table below. Straight fittings should be chosen highest flow rates. Rates as elbow and banjo fittings cause restriction.

The chart below is intended to help when selecting the correct size of tube to use between the valve and the cylinder.

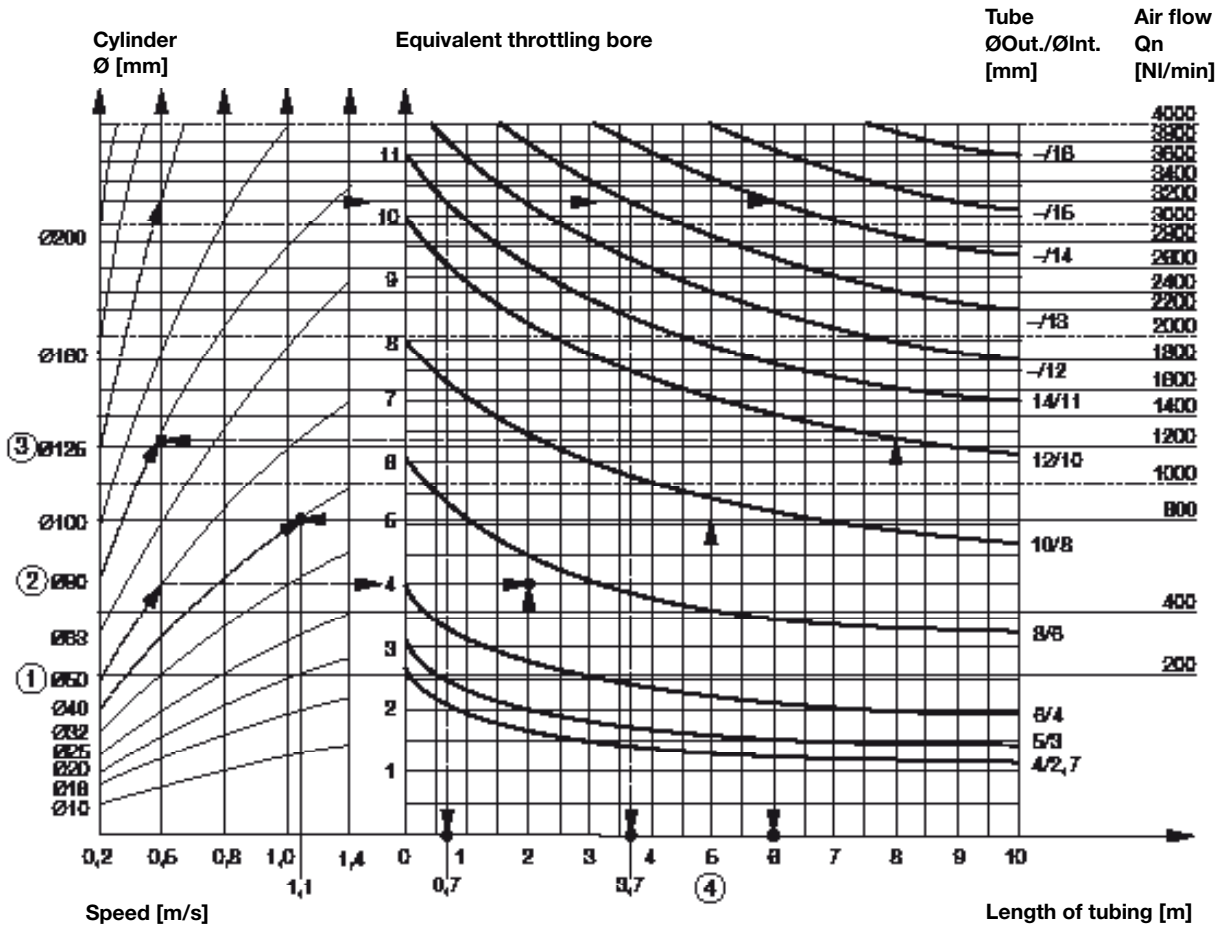

The equivalent throttling bore is a long throttle (for example a tube) or a series of throttles (for example, through a valve) converted to a short throttle which gives a corresponding flow rate. This should not be confused with the orifice which is sometimes specified for valves. The value for the orifice does not normally take account of the fact that the valve contains a number of throttles.

Qn is a measure of the valve flow capacity, with flow measured in liter per minute (l/min) at 6 bar(e) supply pressure and 1 bar pressure drop across the valve.

**Example ①:**

**Which tube diameter should be used?**

A 50 mm bore cylinder is to be operated at 0.5 m/s. The tube length between the valve and cylinder is 2 m. In the diagram we follow the line from 50 mm bore to 0.5 m/s and get an "equivalent throttling bore" of approximately 4 mm. We continue out to the right in the chart and intersect the line for a 2 m tube between the curves for 4 mm (6/4 tube) and 6 mm (8/6 tube). This means that a 6/4 tube throttles the velocity somewhat, while an 8/6 tube is a little too large. We select the 8/6 tube to obtain full cylinder velocity.

**Example ②:**

**What cylinder velocity will be obtained?**

A 80 mm bore cylinder will be used, connected by 8 m 12/10 tube to a valve with Qn 1200 NI/min. What cylinder velocity will we get? We refer to the diagram and follow the line from 8 m tube length up to the curve for 12/10 tube. From there, we go horizontally to the curve for the Ø80 cylinder. We find that the velocity will be about 0.5 m/s.

**Example ③:**

**What is the minimum inner diameter and maximum length of tube?**

For an application a 125 mm bore cylinder will be used. Maximum velocity of piston rod is 0.5 m/s. The cylinder will be controlled by a valve with Qn 3200 NI/min. What diameter of tube can be used and what is maximum length of tube. We refer to the diagram. We start at the left side of the diagram

cylinder Ø125. We follow the line until the intersection with the velocity line of 0.5 m/s. From here we draw a horizontal line in the diagram. This line shows us we need an equivalent throttling bore of approximately 10 mm.

Following this line horizontally we cross a few intersections. These intersections shows us the minimum inner diameter (rightside diagram) in combination with the maximum length of tube (bottomside diagram).

**For example:**

Intersection one: When a tube (14/11) will be used, the maximum length of tube is 0.7 meter.

Intersection two: When a tube (—/13) will be used, the maximum length of tube is 3.7 meter.

Intersection three: When a tube (—/14) will be used, the maximum length of tube is 6 meter.

**Example ④: Determining tube size and cylinder velocity with a particular cylinder and valve?**

For an application using a 40 mm bore cylinder with a valve with Qn=800 NI/min. The distance between the cylinder and valve has been set to 5 m.

Tube dimension: What tube bore should be selected to obtain the maximum cylinder velocity? Start at pipe length 5 m, follow the line up to the intersection with 800 NI/min. Select the next largest tube diameter, in this case Ø10/8 mm. Cylinder velocity: What maximum cylinder velocity will be obtained? Follow the line for 800 NI/min to the left until it intersects with the line for the Ø40 mm cylinder. In this example, the speed is just above 1.1 m/s.

**Cushioning Characteristics**

Air cushion is used to absorb kinetic energy due to load and speed at both end of stroke.

This typically consists of a threaded needle screw that adjusts into an orifice in the cylinder end plate.

By adjusting the screw further into the orifice you lessen the amount of air that can escape in a given time.

Slowing the exhaust of air creates back pressure which slows the piston as it enters into the end cushioning seal.

The mass is the sum of internal and external friction, plus any gravitational forces.

Work out your expected moving mass and read off the maximum permissible speed at start of cushioning.

Alternatively, take your desired speed an expected mass and find the cylinder bore size required.

Please note that piston speed at start of cushioning is typically approx. 50 % higher than the average speed and that it is this higher speed which determines the choice of cylinder.

The graph is valid for an horizontal movement and the pressure of 6 bar.

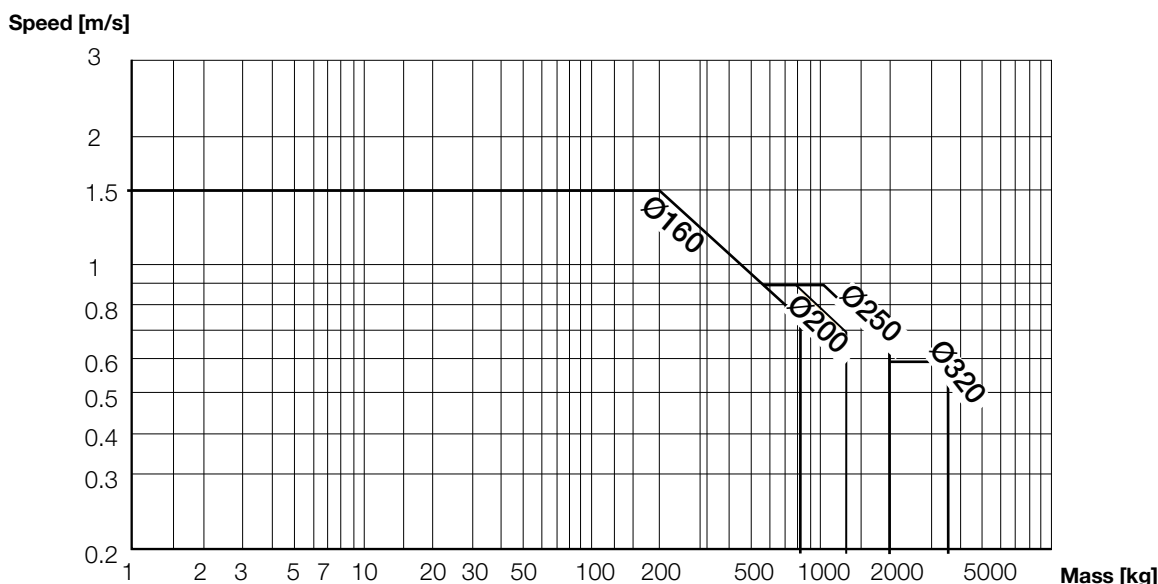

**Dimensions**

**Tie rods with round profile design**

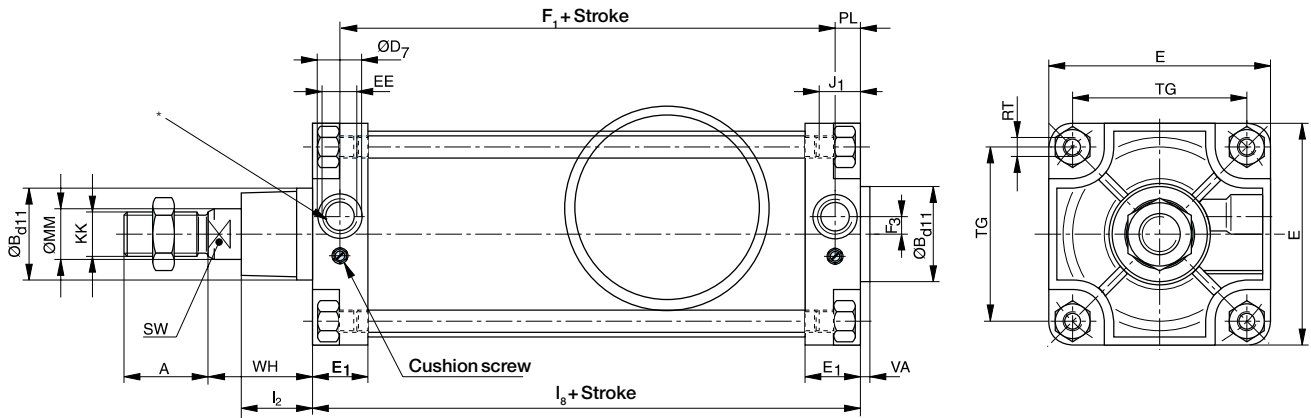

**Note** \*: front air port is on the bottom of the axis of the cylinder and the cushioning screw on the top

**Dimensions [mm] standard temperature**

Cyl.- bore	A	ØB <sub>d11</sub>	ØD <sub>7</sub>	E	E <sub>1</sub>	F <sub>1+Stroke</sub>	F <sub>3</sub>	J <sub>1max.</sub>	I <sub>2</sub>	I <sub>8+Stroke</sub>	EE	KK	MM	PL	RT	SW	TG	VA	WH
[mm]	[mm]	[mm]	[mm]	[mm]	[mm]	[mm]	[mm]	[mm]	[mm]	[mm]	[mm]	[mm]	[mm]	[mm]	[mm]	[mm]	[mm]	[mm]	[mm]
Ø160	72	65	33	180	45	130	11	23	50	180	G3/4	M36x2	40	25	M16	36	140	6	80
Ø200	72	75	33	220	45	130	15	23	60	180	G3/4	M36x2	40	25	M16	36	175	6	95
Ø250	84	90	-	270	51	149	-14*/14	27	69	200	G1	M42x2	50	25.5	M20	46	220	10	107
Ø320	96	110	-	340	56	164	-20*/20	28	82	220	G1	M48x2	63	28	M24	55	270	10	120

**Dimensions [mm] high temperature**

Cyl.- bore	A	ØB <sub>d11</sub>	ØD <sub>7</sub>	E	E <sub>1</sub>	F <sub>1+Stroke</sub>	F <sub>3</sub>	J <sub>1max.</sub>	I <sub>2</sub>	I <sub>8+stroke</sub>	EE	KK	MM	PL	RT	SW	TG	VA	WH
[mm]	[mm]	[mm]	[mm]	[mm]	[mm]	[mm]	[mm]	[mm]	[mm]	[mm]	[mm]	[mm]	[mm]	[mm]	[mm]	[mm]	[mm]	[mm]	[mm]
Ø160	72	65	-	186	47	133	-13.5*/13.5	23	55	180	G3/4	M36x2	40	23.5	M16	36	140	6	80
Ø200	72	75	-	220	47	133	-13.5*/13.5	23	65	180	G3/4	M36x2	40	23.5	M16	36	175	6	95
Ø250	84	90	-	270	51	149	-14*/14	27	69	200	G1	M42x2	50	25.5	M20	46	220	10	107
Ø320	96	110	-	340	56	164	-20*/20	28	82	220	G1	M48x2	63	28	M24	55	270	10	120

**Tolerances [mm]**

Cyl.- bore	I <sub>8</sub>	TG	stroke tolerance	stroke tolerance
[mm]	[mm]	[mm]	<= 500 mm	> 500 mm
Ø160	± 1.1	± 1.1	+ 0.3 / + 2.0	+ 0.3 / + 3.0
Ø200	± 1.6	± 1.1	+ 0.3 / + 2.0	+ 0.3 / + 3.0
Ø250	± 1.6	± 1.5	+ 0.3 / + 2.0	+ 0.3 / + 3.0
Ø320	± 2.2	± 1.5	+ 0.3 / + 2.0	+ 0.3 / + 3.0

Tie rods with through piston rod on request.

### Order Key Code

Standard temperature with magnet, stainless steel piston rod
P1D-T160MS-stroke <sup>1)</sup>
P1D-T200MS-stroke <sup>1)</sup>
P1D-T250/G50053-stroke <sup>1)</sup>
P1D-T320MS-stroke <sup>1)</sup>
Standard temperature with magnet, chromium plated steel piston rod
P1D-T160MC-stroke <sup>1)</sup>
P1D-T200MC-stroke <sup>1)</sup>
P1D-T250/G50120-stroke <sup>1)</sup>
P1D-T320MC-stroke <sup>1)</sup>
Standard temperature with magnet, metallic scraper option, chromium plated steel piston rod
P1D-T160QC-stroke <sup>1)</sup>
P1D-T200QC-stroke <sup>1)</sup>
P1D-T250/G50121-stroke <sup>1)</sup>
P1D-T320QC-stroke <sup>1)</sup>
<sup>1)</sup> without magnet replace P1D- by P1DF

**Note:**

For ATEX version add -EXNN at the end of the part number. Temperature -20°C to +60°C, MS version without trunnion option only for bores 160 & 200 mm.

High temperature without magnet, stainless steel piston rod
P1D-T160/G50079-stroke
P1D-T200/G50080-stroke
P1D-T250/G50053-stroke
P1D-T320MF-stroke
High temperature with magnet, stainless steel piston rod
P1DWT160/G50081-stroke
P1DWT200/G50082-stroke
P1DWT250/G50083-stroke
P1DWT320MF-stroke

Note for all bore sizes:

With trunnion option add NGxxx where xxx represents XV measure in mm at the end of the part number. Trunnion pivots at 90° Vs Air ports.

With trunnion option add N7xxx where xxx represents XV measure in mm at the end of the part number. Trunnion pivots at 0° Vs Air ports.

Through piston rod option on request.

### Standard strokes

Standard strokes for all P1D-T cylinders comply with ISO 4393. Non standard strokes up to 2000 mm.

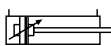
Order no	Cylinder-bore	● = Standard stroke (mm)										= Stroke to special order		
XXXX = Stroke	(mm)	50	80	100	125	160	200	250	320	400	500	800	1000	2000
<b>P1D-T</b>														
<b>P1D-T160MS-XXXX</b>	<b>160</b>	●	●	●	●	●	●	●	●	●		//	//	
<b>P1D-T200MS-XXXX</b>	<b>200</b>	●	●	●	●	●	●	●	●	●		//	//	
<b>P1D-T250/-G...</b>	<b>250</b>	●	●	●	●	●	●	●	●	●		//	//	
<b>P1D-T320MS-XXXX</b>	<b>320</b>	●	●	●	●	●	●	●	●	●		//	//	

**Mountings**

Flange MF1 / MF2 ①



Foot brackets MS1 ②



Pivot bracket with rigid bearing AB7 ③



Swivel eye bracket MP6 ④



Clevis bracket MP2 ⑤



Ø160	P1C-4SMB	P1C-4SMF	P1C-4SMDB	P1C-4SMSB	P1C-4SMTB
Ø200	P1C-4TMB	P1C-4TMF	P1C-4TMDB	P1C-4TMSB	P1C-4TMTB
Ø250	P1C-4VMB	P1C-4VMF	P1C-4VMDB	P1C-4VMSB	P1C-4VMTB
Ø320	P1C-4WMB	P1C-4WMF	P1C-4WMDC	P1C-4WMSB	P1C-4WMTB

Clevis bracket MP4 ⑥



Swivel rod eye AP6 ⑫



Clevis AP2 ⑬



Flexo coupling PM5 ⑭



Ø160	P1C-4SMEB	P1C-4SRS	P1C-4SRC	P1C-4SRF
Ø200	P1C-4TMEB	P1C-4SRS	P1C-4SRC	P1C-4SRF
Ø250	P1C-4VMEB	P1C-4VRS	P1C-4VRC	P1C-4VRF
Ø320	P1C-4WMEB	P1C-4WRS	P1C-4WRC	P1C-4WRF

**Flange MF1/MF2 ①**



Intended for fixed mounting of cylinder.  
Flange can be fitted to front or rear end cover of cylinder.

**Materials:**

Flange: Surface-treated steel  
Mounting screws acc. to DIN 6912:  
Zinc-plated steel 8.8  
Supplied complete with mounting screws for attachment to the cylinder.

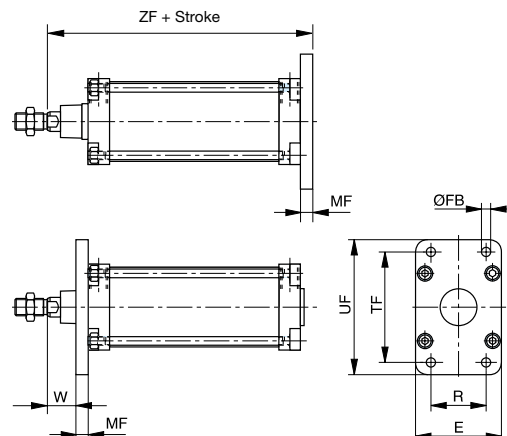

Cyl.-bore [mm]	ZF [mm]	MF [mm]	W [mm]	UF [mm]	E [mm]	TF [mm]	R [mm]	ØFB [mm]	Weight [kg]	Order code
Ø160	280	20	60	260	180	230	115	18	6.69	<b>P1C-4SMB</b>
Ø200	300	25	70	300	220	270	135	22	11.55	<b>P1C-4TMB</b>
Ø250	330	25	80	400	285	330	165	26	20.15	<b>P1C-4VMB</b>
Ø320	370	30	90	470	350	400	200	33	34.55	<b>P1C-4WMB</b>

**Foot brackets MS1 ②**



Intended for fixed mounting of cylinder.  
Foot bracket can be fitted to front or rear end cover of the cylinder.

**Materials:**

Flange: Surface-treated steel  
Mounting screws acc. to DIN 6912:  
Zinc-plated steel 8.8:  
Intended for fixed mounting of the cylinder.  
Foot brackets can be fitted to the front or rear end cover of the cylinder.

Supplied complete with mounting screws for attachment to the cylinder.

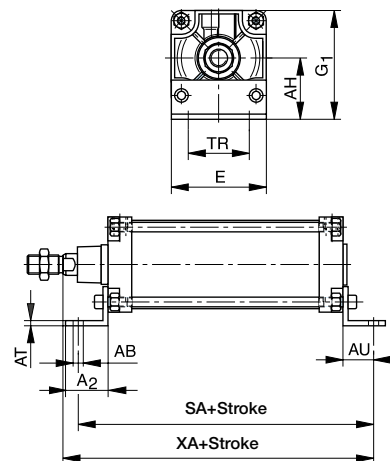

Cyl.-bore [mm]	E [mm]	TR [mm]	AH [mm]	G1 [mm]	AT [mm]	A2 [mm]	ØAB [mm]	SA [mm]	XA [mm]	AU [mm]	Weight [mm]	Order code
Ø160	180	115	115	208	10	75	18,5	300	320	60	2.24	<b>P1C-4SMF</b>
Ø200	220	135	135	245	12	100	24	320	345	70	3.72	<b>P1C-4TMF</b>
Ø250	270	165	165	300	14	100	26	350	382	75	6.60	<b>P1C-4VMF</b>
Ø320	340	200	200	370	23	120	33	390	425	85	17.00	<b>P1C-4WMF</b>

**Pivot bracket with rigid bearing AB7** ③



Intended for flexible mounting of cylinder.  
The pivot bracket can be combined with clevis bracket MP2.

**Materials:**

Pivot bracket: Aluminium

Bush: Steel and PTFE

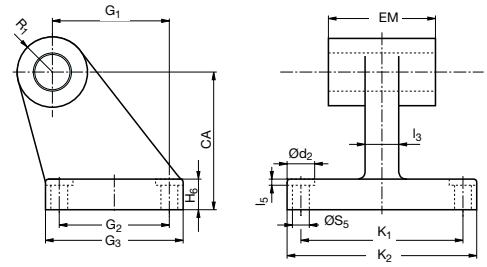

Cyl.-bore [mm]	R1 [mm]	ØCX <sub>H7</sub> [mm]	G1 [mm]	CA [mm]	H6 [mm]	G2 [mm]	G3 [mm]	EM [mm]	I3 [mm]	Ød2 [mm]	I5 [mm]	ØS5 [mm]	K1 [mm]	K2 [mm]	Weight [mm]	Order code
Ø160	31.5	30	97	115	25	88	126	90	36	20	4	14	118	156	2.58	<b>P1C-4SMDB</b>
Ø200	31.5	30	105	135	30	90	130	90	40	26	4	18	122	162	3.30	<b>P1C-4TMDB</b>
Ø250	40	40	128	165	35	110	160	110	45	33	4.5	22	150	200	5.70	<b>P1C-4VMDB</b>
Ø320	45	45	150	200	40	122	186	120	55	-	-	26	170	234	21.90	<b>P1C-4WMDC</b>

**Swivel eye bracket MP6** ④



Intended for use together with clevis bracket AB6.

**Materials:**

Bracket: Aluminium

Swivel bearing acc. to DIN 648K:

Hardened steel

Supplied complete with mounting screws for attachment to cylinder.

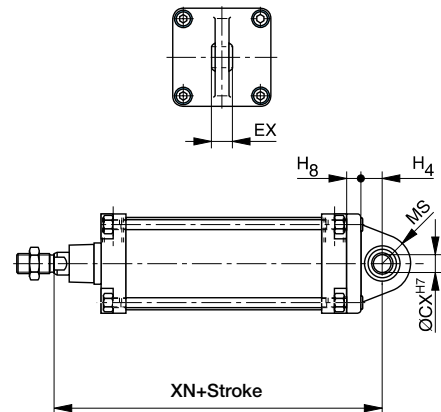

Cyl.-bore [mm]	EX [mm]	XN [mm]	H8 [mm]	H4 [mm]	MS [mm]	ØCX <sub>H7</sub> [mm]	Weight [kg]	Order code Not anodised
Ø160	43	315	20	35	44	35	4.36	<b>P1C-4SMSB</b>
Ø200	43	335	25	35	47	35	3.72	<b>P1C-4TMSB</b>
Ø250	49	377	25	45	52	40	5.85	<b>P1C-4VMSB</b>
Ø320	60	420	30	50	63	45	30.30	<b>P1C-4WMSB</b>

**Clevis bracket MP2** ⑤



Intended for flexible mounting of the cylinder. Clevis bracket MP4 can be combined with pivot bracket and swivel rod eye.

**Materials:**

- Clevis bracket: Aluminium
- Pin: Surface hardened steel
- Locking pin: Spring steel
- Circlips according to DIN 471: Spring steel
- Mounting screws acc. to DIN 912: Zinc-plated steel 8.8

Supplied complete with mounting screws for attachment to the cylinder.

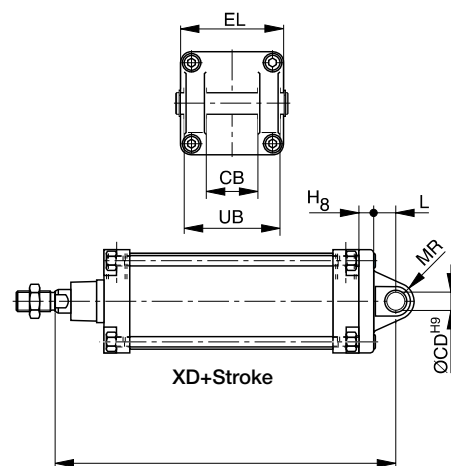

Cyl.-bore [mm]	EL [mm]	XD [mm]	ØCD <sup>H9</sup> [mm]	CB <sup>H14</sup> [mm]	UB [mm]	H8 [mm]	L [mm]	MR [mm]	Weight [kg]	Order code
Ø160	180	315	30	90	170	20	35	25	2.20	<b>P1C-4SMTB</b>
Ø200	220	335	30	90	170	25	35	25	3.47	<b>P1C-4TMTB</b>
Ø250	270	377	40	110	200	25	45	40	5.80	<b>P1C-4VMTB</b>
Ø320	340	420	45	120	220	30	50	54	31.00	<b>P1C-4WMTB</b>

**Clevis bracket MP4** ⑥



Intended for flexible mounting of cylinder. Clevis bracket MP4 can be combined with clevis bracket MP2.

**Materials:**

- Clevis bracket: Aluminium
- Bush: PTFE
- Mounting screws acc. to DIN 912: Zinc-plated steel 8.8

Supplied complete with mounting screws for attachment to the cylinder.

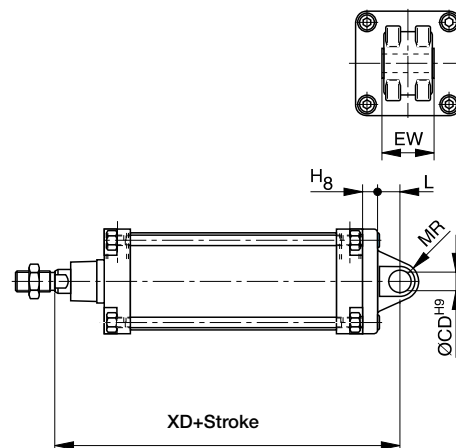

Cyl.-bore [mm]	EW [mm]	XD [mm]	H8 [mm]	L [mm]	MR [mm]	ØCD [mm]	Weight [kg]	Order code
Ø160	90	315	20	35	30	30	2.31	<b>P1C-4SMEB</b>
Ø200	90	335	25	35	31	30	2.50	<b>P1C-4TMEB</b>
Ø250	110	375	25	45	41	40	6.20	<b>P1C-4VMEB</b>
Ø320	120	420	30	50	46	45	33.00	<b>P1C-4WMEB</b>

**Intermediate trunnion  
MT4**



The trunnion is MT4 for P1D-T factory-fitted at an optional MT4 location specified by the XV-measure:

**Material:**

Trunnion: Zinc plated steel

The trunnion for the P1D-T is ordered with letter G or 7 in position 17 and desired XV-measure (3-digit measure in mm) in positions 18-20. e.g. P1D-T160MS-0500NG300

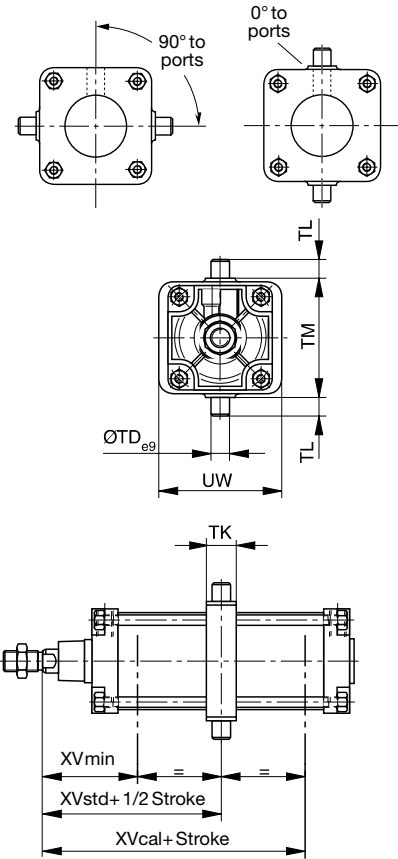

**Standard temp version**

Cyl.-bore [mm]	TK <sub>h14</sub> [mm]	TL <sub>h14</sub> [mm]	TM [mm]	ØTD <sub>e9</sub> [mm]	UW [mm]	XV <sub>min</sub> [mm]	XV <sub>std</sub> [mm]	XV <sub>cal</sub> [mm]	Weight [kg]
Ø160	40	32	200	32	190	145	170	195	6.10
Ø200	40	32	250	32	240	160	185	210	8.10
Ø250	50	40	320	40	296	194	205	216	14.80
Ø320	65	50	400	50		210	230	251	16.00

**High temp version**

Ø160	48	32	200	32	190	151	170	189	6.10
Ø200	48	32	250	32	240	166	185	204	8.10
Ø250	60	40	320	40	296	188	207	226	14.80
Ø320	65	50	400	50		210	230	251	16.00

**Important:**

If the cylinder is ordered with a piston rod protusion (WH dimension), please add this extra length to XV<sub>min</sub>, XV<sub>std</sub> and XV<sub>max</sub>.

**Swivel rod eye AP6** <sup>12</sup>



Swivel rod eye for articulated mounting of the cylinder

**Materials:** Swivel rod eye: Zinc-plated steel  
Swivel bearing according to DIN 648K:  
Hardened steel

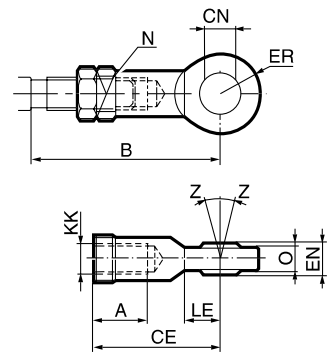

According to ISO 8139

Cyl.-bore [mm]	A [mm]	B <sub>min</sub> [mm]	CE [mm]	ØCN <sub>H9</sub> [mm]	EN <sub>h12</sub> [mm]	ER [mm]	KK [mm]	LE <sub>min</sub> [mm]	N [mm]	O [mm]	Weight [kg]	Order code
Ø160	56	141	125	35	43	40,5	M36x2	41	50	28	1.6	<b>P1C-4SRS</b>
Ø200	56	141	125	35	43	40,5	M36x2	41	50	28	1.6	<b>P1C-4SRS</b>
Ø250	60	164	142	40	49	45,5	M42x2	46	55	33	2.4	<b>P1C-4VRS</b>
Ø320	65	191	160	50	60	58,5	M48x2	59	65	45	5.0	<b>P1C-4WRS</b>

**Clevis AP2** <sup>13</sup>



Clevis for articulated mounting of the cylinder.

**Materials:** Clevis, clip: Galvanized steel  
Pin: Hardened steel

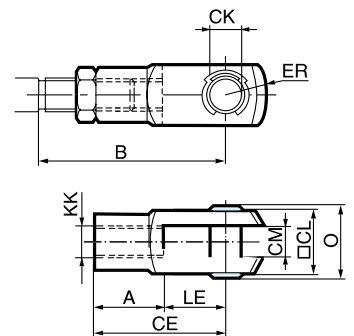

According to ISO 8140

Cyl.-bore [mm]	A [mm]	B <sub>min</sub> [mm]	CE [mm]	CK <sub>h11/e9</sub> [mm]	CL [mm]	CM [mm]	ER [mm]	KK [mm]	LE [mm]	O [mm]	Weight [kg]	Order code
Ø160	72	144	144	35	70	35	-	M36x2	72	-	2.93	<b>P1C-4SRC</b>
Ø200	72	144	144	35	70	35	-	M36x2	72	-	2.93	<b>P1C-4SRC</b>
Ø250	84	168	168	40	85	40	-	M42x2	84	-	5.64	<b>P1C-4VRC</b>
Ø320	96	192	192	50	96	50	-	M48x2	96	-	7.86	<b>P1C-4WRC</b>

**Flexo coupling PM5** <sup>14</sup>



Flexo coupling for articulated mounting of piston rod. Flexo fitting is intended to take up axial angle errors within a range of ±4°.

**Material:**  
Flexo coupling, nut: Zinc-plated steel  
Supplied complete with galvanized adjustment nut.

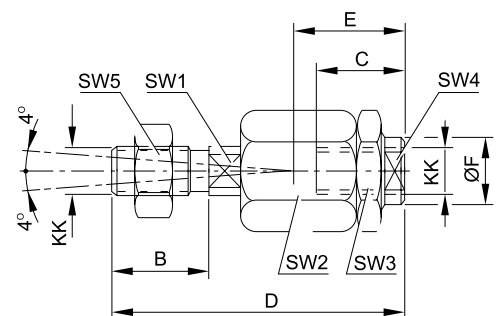

Cyl.-bore [mm]	KK [mm]	B [mm]	C [mm]	D [mm]	E [mm]	ØF [mm]	SW1 [mm]	SW2 [mm]	SW3 [mm]	SW4 [mm]	SW5 [mm]	Weight [kg]	Order code
Ø160	M36x2	72	50	241	110	56	36	75	75	50	55	5.1	<b>P1C-4SRF</b>
Ø200	M36x2	72	50	241	110	56	36	75	75	50	55	5.1	<b>P1C-4SRF</b>
Ø250	M42x2	82	88	271	120	64	36	85	85	60	65	9.2	<b>P1C-4VRF</b>
Ø320	M48x2	82	88	271	120	64	42	85	85	60	75	9.4	<b>P1C-4WRF</b>

## Drop-in sensors

The P8S sensors can easily be installed from the side in the sensor groove, at any position along the piston stroke.

The sensors are completely recessed and thus mechanically protected. Choose between electronic or reed sensors and several cable lengths and 8 mm and M12 connectors.



## Electronic sensors

The electronic sensors are "Solid State", i.e. they have no moving parts at all. They are provided with short-circuit protection and transient protection as standard. The built-in electronics make the sensors suitable for applications with high on and off switching frequency, and where very long service life is required.

## Reed sensors

The sensors are based on proven reed switches, which offer reliable function in many applications. Simple installation, a protected position on the cylinder and clear LED indication.

	Electronic	Reed
Cylinder type:		Profile with T-slot
Cylinder type with adaptor:		Profile with S-slot (dovetail)   Tie rods   Round cylinders
Installation:	Drop-in. Fixed by 1.5 mm stainless steel allen key or flathead screwdriver.	
Housing length:	34.7 mm   31.5 mm (ATEX)	
Output Type / Function:	PNP, Normally Open (NO)   NPN, Normally Closed (NC)	Normally Open (NO)   Normally Closed (NC)
Switching (on/off) switching frequency:	≤1000 Hz	± 400 Hz
Degree of Protection (IP):		IP67
Power consumption:	≤ 10 mA	-
Input Supply Voltage Range:	10 to 30 V DC   18 to 30 V DC (ATEX)	10 to 30   10 to 120   10 to 230 V AC/DC (2-wire)   10 to 30 V AC/DC (3-wire)
Voltage Drop:	≤ 2.2 V	≤ 3,5 V (2-wire NO)   ≤ 0,1 V (3-wire)   ≤ 0,1 V (2-wire NC)
Continuous output current:	≤ 100 mA   ≤ 70 mA (ATEX)	≤ 100 mA (2-wire NO)   ≤ 500 mA (3-wire)   ≤ 500 mA (2-wire NC)
Switching capacity:	-	≤ 10 W
Hazardous area category:	3G / 3D (ATEX)	-
Protection Class:	III	II (2-wire)   III (3-wire)
Response Sensitivity:	2.65.. 2.95 mT	2.1.. 3.4 mT
Overrun Distance:	3 mm	9 mm
Hysteresis:	≤ 0.5 mT	≤ 0.2 mT
Repeatability:	≤ 0.1 mT	
Reverse Polarity Protection:	Yes	
Short-circuit Protection:	Yes	-
Power-up Pulse Protection:	Yes	-
Ambiant Operating Temperature Range:	-25 to +75 °C (PUR cable)   -20 to +70°C (PVC cable)   -20 to +45°C (ATEX)	
Shock and Vibration resistance:	30 g 11 ms / 10 ... 55 Hz, 1 mm	
EMC:	According to EN 60947-5-2	
Industry Standard:	CE   C UL US   RoHs   Ex	CE   C UL US   RoHs
UL Certification:		On request
Housing Material:	Plastic polyamid PA12 (ATEX)   PA66	Plastic polyamid PA12 (2-wire 240V)   PA66
Cable Specification:	PUR (Polyurethane)   PVC (Polyvinyl Chloride)	
Conductor Cross-Section:	0.14 mm <sup>2</sup> (3 wire)	0.14 mm <sup>2</sup> (3-wire)   0.12 mm <sup>2</sup> (2-wire)
Colour of LED:		Yellow
Connection Style:	M8 snap-in   M8R (knurled nuts)   M12 (knurled nuts)   None (Flying lead)	

**Electronic sensors**

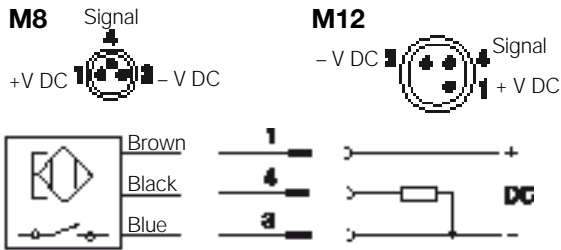

**Reed sensors**

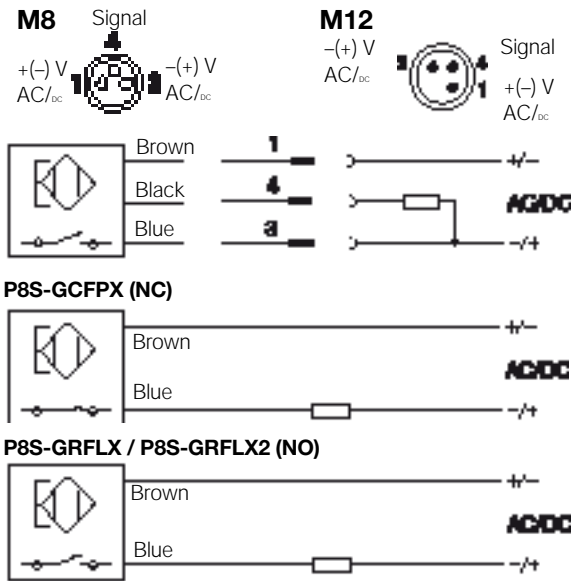

**Dimensions [mm]**

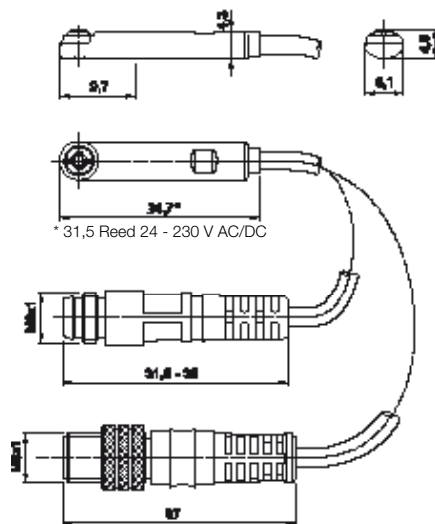

**Sensor Installation**

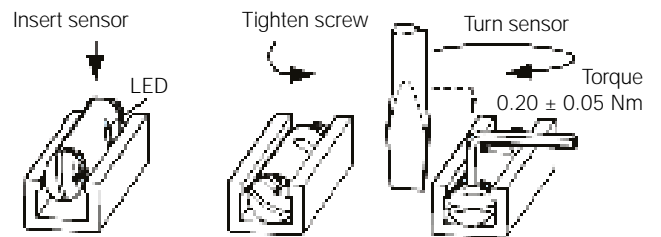

**Brackets for sensors**

Oder code: PD48956 - bores Ø160 - Ø320 mm

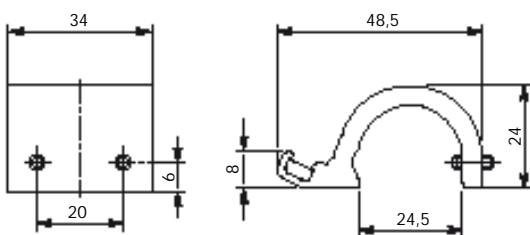

## Ordering data

Output/function	Cable/connector	Weight [kg]	Order code
<b>Electronic sensors, 10-30 V DC</b>			
PNP type, normally open	0.27 m PUR cable and 8 mm snap-in male connector	0.007	<b>P8S-GPSHX</b>
PNP type, normally open	0.27 m PUR cable and M12 screw male connector	0.015	<b>P8S-GPMHX</b>
PNP type, normally open	3 m PVC cable without connector	0.030	<b>P8S-GPFLX</b>
PNP type, normally open	10 m PVC cable without connector	0.110	<b>P8S-GPFTX</b>
<b>Reed sensors, 10-30 V AC/DC</b>			
Normally open	0.27 m PUR cable and 8 mm snap-in male connector	0.007	<b>P8S-GSSHX</b>
Normally open	0.27 m PUR cable and M12 screw male connector	0.015	<b>P8S-GSMHX</b>
Normally open	3 m PVC cable without connector	0.030	<b>P8S-GSFLX</b>
Normally open	10 m PVC cable without connector	0.110	<b>P8S-GSFTX</b>
Normally closed	5 m PVC cable without connector without LED	0.050	<b>P8S-GCFPX</b>
<b>Reed sensors, 10-120 V AC/DC</b>			
Normally open	3 m PVC cable without connector	0.030	<b>P8S-GRFLX</b>
<b>Reed sensors, 24-230 V AC/DC</b>			
Normally open	3 m PVC cable without connector	0.030	<b>P8S-GRFLX2</b>

## Male connectors for connecting cables

Cable connectors for producing your own connecting cables. The connectors can be quickly attached to the cable without special tools. Only the outer sheath of the cable is removed. The connectors are available for M8 screw connectors and meet protection class IP 65.



## Technical data

Operating voltage:	max. 32V AC/DC
Operating current per contact:	max. 4 A
Connection cross section:	0.25... 0.5 mm <sup>2</sup> (conductor diameter min 0.1)
Protection class:	IP65 And IP 67 when plugged and screwed down (EN 60529)
Temperature range:	- 25... +85°C

Connector	Weight [kg]	Order Code
M8 screw connector		<b>P8CS0803J</b>
M12 screw connector	0.022	<b>P8CS1204J</b>

## Connecting cables

Description	Weight [g]	For Product Series	Order Code
Cable flex PVC 3 meter with 8mm snap-in connector / flying leads	70	P8S Sensors with M8	<b>9126344341</b>
Cable flex PVC 10 meter with 8mm snap-in connector / flying leads	210	P8S Sensors with M8	<b>9126344342</b>
Cable PUR 3 meter with 8mm snap-in female connector / flying leads	70	P8S Sensors with M8	<b>9126344345</b>
Cable flex PUR 10 meter with 8mm snap-in connector / flying leads	210	P8S Sensors with M8	<b>9126344346</b>
Cable PVC 2.5 meter with M8 screw connector / flying leads	60	P8S Sensors with knurled M8	<b>KC3102</b>
Cable PVC 5 meter with M8 screw female connector / flying leads	120	P8S Sensors with knurled M8	<b>KC3104</b>

**Seal Kits**

Complete seal kits consisting of:

- Piston complete
- Cushioning seals
- Piston rod bearing
- Scraper ring
- Piston rod seal
- O-rings



Cyl.-bore [mm]	Standard temperature	High temperature <sup>1)</sup>
Ø160	<b>PD23013</b>	<b>P1D-6S/G90010</b>
Ø200	<b>PD25006</b>	<b>P1D-6T/G90011</b>
Ø250	<b>P1D-6V/G90016 <sup>2)</sup></b>	<b>P1D-6V/G90012</b>

<sup>1)</sup> seal kits for cylinder with part number P1DxTxxxMF-stroke ... are no longer available. High temp, only for cylinder with part number P1DxTxxx/G...

<sup>2)</sup> No longer available for cylinder with part number P1DxT250xx-stroke ... built before March 2018. Only for cylinder with part number P1DxT250/G... from March 2018.



Standard	4 g tube	<b>KL8220</b>
High temperature	4 g tube	<b>KL8220</b>

Cyl.-bore [mm]	Through rod standard temperature
Ø160	<b>P1D-6SRNF</b>
Ø200	<b>P1D- 6TRNF</b>
Ø250	-

**Seal kit for bores Ø 160 - Ø 250 mm**

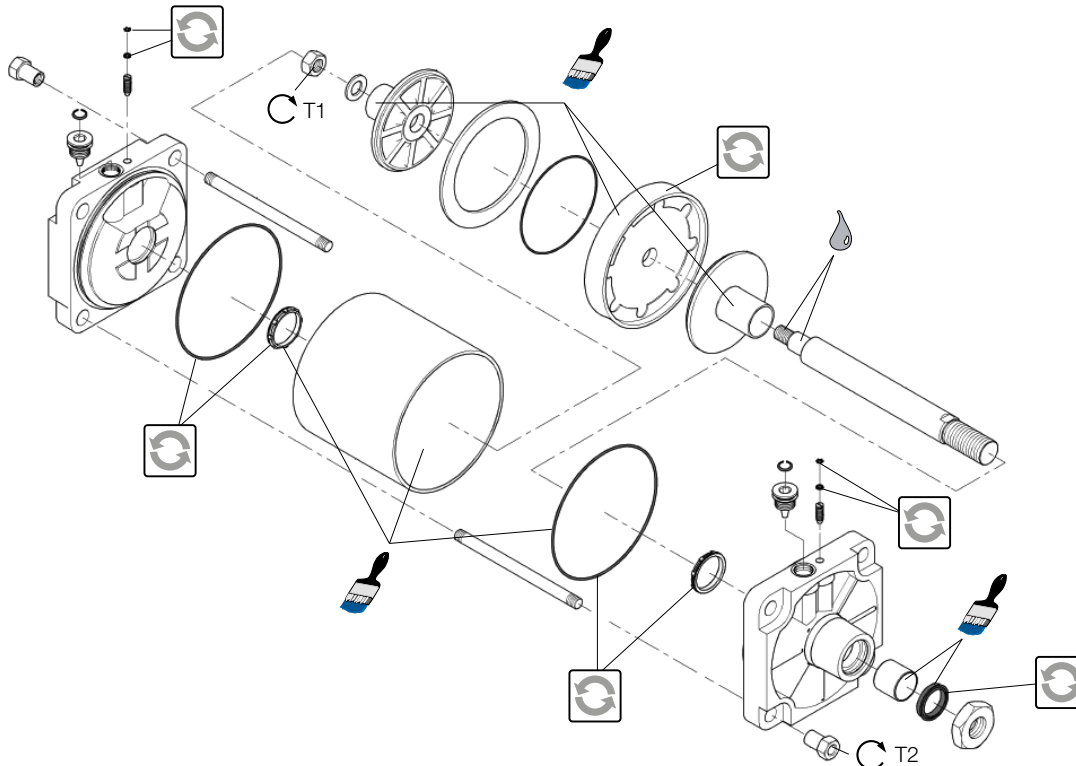

- = Included in seal kit
- = Lubricated with grease
- = Locking fluid
- = Nut A/F
- = Socket head
- = Tightening torque

Loctite LT638 locking fluid must be used

Cyl.-bore [mm]	Plastic piston T1 [Nm]	AF [mm]	T2 [Nm]	AF [mm]
Ø160	100	30	85	27
Ø200	100	30	95	27
Ø250	120	36	140	41

**Seal Kits**

Complete seal kits consisting of:

- Piston seals
- Cushioning seals
- Piston rod bearing
- Scraper ring
- Piston rod seal
- O-rings



Cyl.-bore [mm]	Standard	High Temp.
Ø320	KL7339	KL7340

Cyl.-bore [mm]	Through rod Standard temperature
Ø320	P1D-6WRNF



Standard	4 g tube	KL8220
High temperature	4 g tube	KL8220

**Seal kit for bore Ø 320 mm**

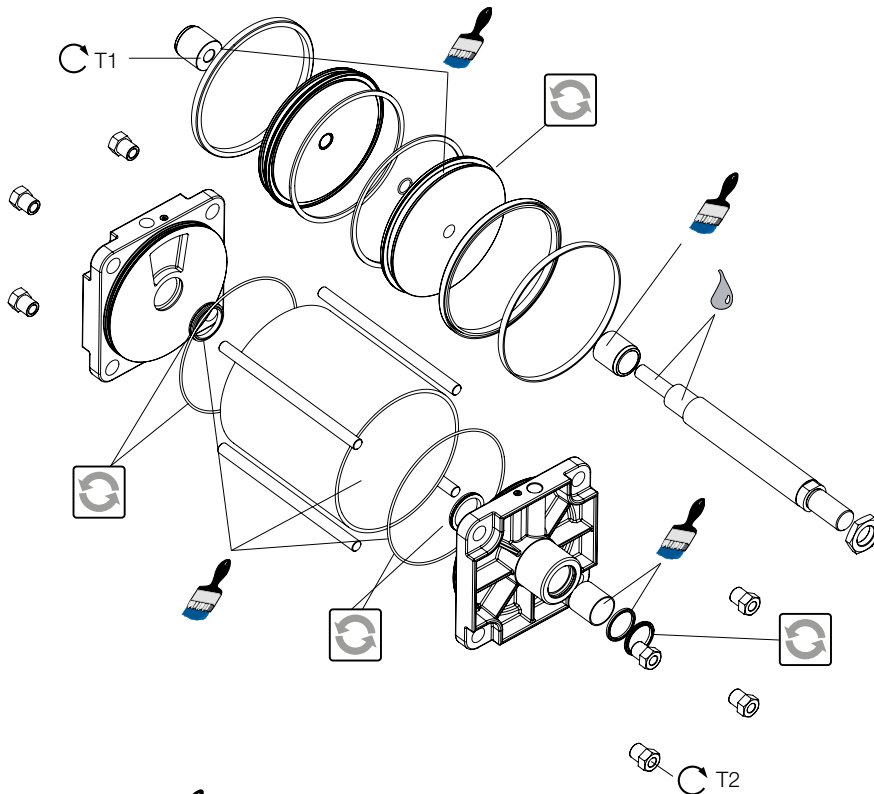

- = Included in seal kit
- = Lubricated with grease
- = Socket head
- = Locking fluid
- = Tightening torque
- = Nut A/F

Loctite LT638 locking fluid must be used

Cyl.-bore	Piston			
[mm]	T1 [Nm]	AF [mm]	T2 [Nm]	AF [mm]
Ø320	250	30	200	41

# Specifying air quality (purity) in accordance with ISO8573-1:2010, the international standard for Compressed Air Quality

ISO8573-1 is the primary document used from the ISO8573 series as it is this document which specifies the amount of contamination allowed in each cubic metre of compressed air.

ISO8573-1 lists the main contaminants as Solid Particulate, Water and Oil. The purity levels for each contaminant are shown separately in tabular form, however for ease of use, this document combines all three contaminants into one easy to use table.

ISO8573-1:2010 CLASS	Solid Particulate			Mass Concentration mg/m <sup>3</sup>	Water		Oil
	Maximum number of particles per m <sup>3</sup>				Vapour Pressure Dewpoint	Liquid g/m <sup>3</sup>	Total Oil (aerosol liquid and vapour) mg/m <sup>3</sup>
	0,1 - 0,5 micron	0,5 - 1 micron	1 - 5 micron				
0	As specified by the equipment user or supplier and more stringent than Class 1						
1	≤ 20 000	≤ 400	≤ 10	-	≤ -70 °C	-	0,01
2	≤ 400 000	≤ 6 000	≤ 100	-	≤ -40 °C	-	0,1
3	-	≤ 90 000	≤ 1 000	-	≤ -20 °C	-	1
4	-	-	≤ 10 000	-	≤ +3 °C	-	5
5	-	-	≤ 100 000	-	≤ +7 °C	-	-
6	-	-	-	≤ 5	≤ +10 °C	-	-
7	-	-	-	5 - 10	-	≤ 0,5	-
8	-	-	-	-	-	0,5 - 5	-
9	-	-	-	-	-	5 - 10	-
X	-	-	-	> 10	-	> 10	> 10

## Specifying air purity in accordance with ISO8573-1:2010

When specifying the purity of air required, the standard must always be referenced, followed by the purity class selected for each contaminant (a different purity class can be selected for each contamination if required).

An example of how to write an air quality specification is shown below:

### ISO 8573-1:2010 Class 1.2.1

ISO 8573-1:2010 refers to the standard document and its revision, the three digits refer to the purity classifications selected for solid particulate, water and total oil. Selecting an air purity class of 1.2.1 would specify the following air quality when operating at the standard's reference conditions :

#### Class 1 - Particulate

In each cubic metre of compressed air, the particulate count should not exceed 20,000 particles in the 0.1 - 0.5 micron size range, 400 particles in the 0.5 - 1 micron size range and 10 particles in the 1 - 5 micron size range.

#### Class 2 - Water

A pressure dewpoint (PDP) of -40°C or better is required and no liquid water is allowed.

#### Class 1 - Oil

In each cubic metre of compressed air, not more than 0.01mg of oil is allowed. This is a total level for liquid oil, oil aerosol and oil vapour.

## ISO8573-1:2010 Class zero

- Class 0 does not mean zero contamination.
- Class 0 requires the user and the equipment manufacturer to agree contamination levels as part of a written specification.
- The agreed contamination levels for a Class 0 specification should be within the measurement capabilities of the test equipment and test methods shown in ISO8573 Pt 2 to Pt 9.
- The agreed Class 0 specification must be written on all documentation to be in accordance with the standard.
- Stating Class 0 without the agreed specification is meaningless and not in accordance with the standard.
- A number of compressor manufacturers claim that the delivered air from their oil-free compressors is in compliance with Class 0.
- If the compressor was tested in clean room conditions, the contamination detected at the outlet will be minimal. Should the same compressor now be installed in typical urban environment, the level of contamination will be dependent upon what is drawn into the compressor intake, rendering the Class 0 claim invalid.
- A compressor delivering air to Class 0 will still require purification equipment in both the compressor room and at the point of use for the Class 0 purity to be maintained at the application.
- Air for critical applications such as breathing, medical, food, etc typically only requires air quality to Class 2.2.1 or Class 2.1.1.
- Purification of air to meet a Class 0 specification is only cost effective if carried out at the point of use.

# Parker Worldwide

## Europe, Middle East, Africa

**AE – United Arab Emirates,** Dubai  
Tel: +971 4 8127100  
parker.me@parker.com

**AT – Austria,** Wiener Neustadt  
Tel: +43 (0)2622 23501-0  
parker.austria@parker.com

**AT – Eastern Europe,** Wiener Neustadt  
Tel: +43 (0)2622 23501 900  
parker.easteurope@parker.com

**AZ – Azerbaijan,** Baku  
Tel: +994 50 2233 458  
parker.azerbaijan@parker.com

**BE/LU – Belgium,** Nivelles  
Tel: +32 (0)67 280 900  
parker.belgium@parker.com

**BG – Bulgaria,** Sofia  
Tel: +359 2 980 1344  
parker.bulgaria@parker.com

**BY – Belarus,** Minsk  
Tel: +48 (0)22 573 24 00  
parker.poland@parker.com

**CH – Switzerland,** Etoy  
Tel: +41 (0)21 821 87 00  
parker.switzerland@parker.com

**CZ – Czech Republic,** Klecany  
Tel: +420 284 083 111  
parker.czechrepublic@parker.com

**DE – Germany,** Kaarst  
Tel: +49 (0)2131 4016 0  
parker.germany@parker.com

**DK – Denmark,** Ballerup  
Tel: +45 43 56 04 00  
parker.denmark@parker.com

**ES – Spain,** Madrid  
Tel: +34 902 330 001  
parker.spain@parker.com

**FI – Finland,** Vantaa  
Tel: +358 (0)20 753 2500  
parker.finland@parker.com

**FR – France,** Contamine s/Arve  
Tel: +33 (0)4 50 25 80 25  
parker.france@parker.com

**GR – Greece,** Athens  
Tel: +30 210 933 6450  
parker.greece@parker.com

**HU – Hungary,** Budaörs  
Tel: +36 23 885 470  
parker.hungary@parker.com

**IE – Ireland,** Dublin  
Tel: +353 (0)1 466 6370  
parker.ireland@parker.com

**IL – Israel**  
Tel: +39 02 45 19 21  
parker.israel@parker.com

**IT – Italy,** Corsico (MI)  
Tel: +39 02 45 19 21  
parker.italy@parker.com

**KZ – Kazakhstan,** Almaty  
Tel: +7 7273 561 000  
parker.easteurope@parker.com

**NL – The Netherlands,** Oldenzaal  
Tel: +31 (0)541 585 000  
parker.nl@parker.com

**NO – Norway,** Asker  
Tel: +47 66 75 34 00  
parker.norway@parker.com

**PL – Poland,** Warsaw  
Tel: +48 (0)22 573 24 00  
parker.poland@parker.com

**PT – Portugal**  
Tel: +351 22 999 7360  
parker.portugal@parker.com

**RO – Romania,** Bucharest  
Tel: +40 21 252 1382  
parker.romania@parker.com

**RU – Russia,** Moscow  
Tel: +7 495 645-2156  
parker.russia@parker.com

**SE – Sweden,** Spånga  
Tel: +46 (0)8 59 79 50 00  
parker.sweden@parker.com

**SL – Slovenia,** Novo Mesto  
Tel: +386 7 337 6650  
parker.slovenia@parker.com

**TR – Turkey,** Istanbul  
Tel: +90 216 4997081  
parker.turkey@parker.com

**UA – Ukraine,** Kiev  
Tel: +48 (0)22 573 24 00  
parker.poland@parker.com

**UK – United Kingdom,** Warwick  
Tel: +44 (0)1926 317 878  
parker.uk@parker.com

**ZA – South Africa,** Kempton Park  
Tel: +27 (0)11 961 0700  
parker.southafrica@parker.com

## North America

**CA – Canada,** Milton, Ontario  
Tel: +1 905 693 3000

**US – USA,** Cleveland  
Tel: +1 216 896 3000

## Asia Pacific

**AU – Australia,** Castle Hill  
Tel: +61 (0)2-9634 7777

**CN – China,** Shanghai  
Tel: +86 21 2899 5000

**HK – Hong Kong**  
Tel: +852 2428 8008

**IN – India,** Mumbai  
Tel: +91 22 6513 7081-85

**JP – Japan,** Tokyo  
Tel: +81 (0)3 6408 3901

**KR – South Korea,** Seoul  
Tel: +82 2 559 0400

**MY – Malaysia,** Shah Alam  
Tel: +60 3 7849 0800

**NZ – New Zealand,** Mt Wellington  
Tel: +64 9 574 1744

**SG – Singapore**  
Tel: +65 6887 6300

**TH – Thailand,** Bangkok  
Tel: +662 186 7000

**TW – Taiwan,** Taipei  
Tel: +886 2 2298 8987

## South America

**AR – Argentina,** Buenos Aires  
Tel: +54 3327 44 4129

**BR – Brazil,** Sao Jose dos Campos  
Tel: +55 800 727 5374

**CL – Chile,** Santiago  
Tel: +56 2 623 1216

**MX – Mexico,** Toluca  
Tel: +52 72 2275 4200

### European Product Information Centre

Free phone: 00 800 27 27 5374

(from AT, BE, CH, CZ, DE, DK, EE, ES, FI, FR, IE, IL, IS, IT, LU, MT, NL, NO, PL, PT, RU, SE, SK, UK, ZA)

### Parker Hannifin Ltd.

Tachbrook Park Drive  
Tachbrook Park,  
Warwick, CV34 6TU  
United Kingdom  
Tel.: +44 (0) 1926 317 878  
Fax: +44 (0) 1926 317 855  
parker.uk@parker.com  
www.parker.com

