



HAS Series A Drive Systems Manual

0991760***_**00-XXXX-A Analog Communications

Modular Drive Systems for AC Motors (Series "A")

AC890SD (Standalone) Drives - Frames B, C & D with STO SIL3/PLe



ENGINEERING YOUR SUCCESS.

In line with our policy of continuing product improvement, specifications and information contained in this catalog are subject to change.

Copyright ©2022 by Parker Hannifin Corporation. All rights reserved.

PRINTED IN THE U.S.A.

⚠ WARNING

FAILURE OR IMPROPER SELECTION OR IMPROPER USE OF THE PRODUCTS AND/OR SYSTEMS DESCRIBED HEREIN OR RELATED ITEMS CAN CAUSE DEATH, PERSONAL INJURY AND PROPERTY DAMAGE.

This document and other information from the Parker Hannifin Corporation, its subsidiaries and authorized distributors provide product and/or system options for further investigation by users having expertise. It is important that you analyze all aspects of your application, including consequences of any failure and review the information concerning the product or system in the current product catalog. Due to the variety of operating conditions and applications for these products or systems, the user, through its own analysis and testing, is solely responsible for making the final selection of the products and systems and assuring that all performance, safety and warning requirements of the application are met.

The products described herein, including without limitation, product features, specifications, designs, availability and pricing, are subject to change by Parker Hannifin Corporation and its subsidiaries at any time without notice.

Offer of Sale

The items described in this document are hereby offered for sale by Parker Hannifin Corporation, its subsidiaries or its authorized distributors. This offer and its acceptance are governed by provisions stated on a separate page of the document entitled 'Offer of Sale'.

⚠ PROP 65 WARNING **WARNING:** This product can expose you to chemicals including **Lead and Lead Compounds** which are known to the State of California to cause cancer and birth defects or other reproductive harm. For more information go to www.P65Warnings.ca.gov



Safety

IMPORTANT Please read this information **BEFORE** installing the equipment.

<p>This manual is for anyone installing, operating and servicing this unit.</p>	<p>You must be technically competent to install and operate this unit.</p>	<p>Before working on the unit, isolate the main supply from terminals L1, L2 and L3 and wait 3 minutes</p>	<p>Disconnect the unit from circuits when doing high voltage resistance checks.</p>
<p>The unit must be permanently earthed due to high earth leakage current</p>	<p>The drive motor must be connected to an appropriate safety earth.</p>	<p>Electrostatic discharge sensitive parts: observe static control precautions.</p>	<p>Copy existing 890 parameters to any replacement 890 unit.</p>

Hazard to Personnel

WARNING!

This equipment can endanger life through rotating machinery and high voltages. Failure to observe the following will constitute an **ELECTRICAL SHOCK HAZARD**.

Metal parts may reach a temperature of 70 degrees Centigrade in operation.

Before working on the equipment, ensure isolation of the main supply from terminals L1, L2 and L3. The equipment contains high value capacitors which discharge slowly after removal of the main supply. Wait for a least 3 minutes for the dc link terminals (DC+ and DC-terminal voltage with a meter to confirm that the voltage is less than 50V.

do not apply external voltage sources (main supply or otherwise to any of the braking terminals (DBR+, DBR-, DC+, INT or EXT)

Application Risk

The specifications, processes and circuitry described herein are for guidance only and may need to be adapted to user's specific application.

Parker Hannifin Manufacturing Limited does not guarantee the suitability of the equipment described in the manual for individual applications.

PROP 65 WARNING **WARNING:** This product can expose you to chemicals including **Lead and Lead Compounds** which are known to the State of California to cause cancer and birth defects or other reproductive harm. For more information go to www.P65Warnings.ca.gov

Risk Assessment

Under fault conditions, power loss or other operating conditions not intended, the equipment may not operate as specified. In particular:

- The motor speed may not be controlled
- The direction of rotation of the motor may not be controlled
- The motor may be energized

If the STO feature of the 890 drive is to be used, the user must undertake a risk assessment for the application. The user must then verify that their design, which includes the 890 drive, satisfies the Performance Level (PL) or Safety Integrity Level (SIL) required by the risk assessment.

Under no circumstances must the STO feature be used without first reading and fully understanding chapter 6 (Safe Torque Off) of the Engineering Reference Manual. All safety warnings therein must be observed.

Accessibility

All live power terminals are IP20 rated only, since the equipment is intended to be installed within a normally-closed cubicle or enclosure, which itself requires a tool to open.

Protective Insulation

- All control and signal terminals are SELV, i.e. protected by double insulation. Ensure all wiring is rated for the highest system voltage.

NOTE *Thermal sensors contained within the motor must be single/basic insulated.*

- All exposed metalwork in the Drive is protected by basic insulation and bonding to a safety earth.

RCDs

Not recommended for use with this product. Where their use is mandatory, use only Type B RCDs (EN61009).

Caution

This is a product of the restricted sales distribution class according to IEC 61800-3. It is designated as “professional equipment” as defined in EN61000-3-2. Permission of the supply authority shall be obtained before connection to the low voltage supply.

 **PROP 65 WARNING** **WARNING:** This product can expose you to chemicals including **Lead and Lead Compounds** which are known to the State of California to cause cancer and birth defects or other reproductive harm. For more information go to www.P65Warnings.ca.gov

HAS Series A Drive System Manual

Modular Drive Systems for AC Motors (Series “A”) AC890SD (Standalone) Drives Frames B, C, D with STO SIL3/PLe

Table of Contents

Safety	3	Mode 1 (10V) Speed /Direction Entry	41
Introduction	6	Mode 2 (0-20 mA) Speed /Direction Entry	42
Panel Installation	7	Mode 3 (4-20 mA) Speed /Direction Entry	43
Wiring Drawing	12	Mode 4 (+/- 10V) Proportional Entry	44
Drive Overview	14	HAS Analog Connections	45
3-Phase Power Connections	16	Stop on Position Entry	46
Motor Connections	17	Stop on Pressure (PSI) Entry	48
HAS Cable Connections	18	Heat Exchanger Operation	50
Minimum Setup Check List	20	Reservoir Temp Sensor Connections	51
6511 Keypad Operation	21	Safe Torque Off (STO) Overview	52
6901 Keypad Operation	24	STO Wire Example	65
6901 / 6052 Keypad Mounting	27	HAS Diagnostics	72
Pump Displacement Entry	28	Operator Menu - Entry items list	75
External Power Supply wiring	29	Diagnostic Menu - Item List	80
Input Overview	30	Drive Trips	91
Operational Mode Entry	31	DSE Software Installation	106
Operational Mode- Basic Direction	32	Communicating with Drive	108
Invert Direction	33	Online Diagnostics	110
Mode 0 V1 Speed Entry	34	Data Monitor / Recording	111
Acceleration Entry	35	Program Blocks	112
Deceleration Entry	36	Frame B Drive Specifications	116
End of Stroke Limit Switch	37	Frame C & D Drive Specifications	117
Invert Limit Switch	38	Resolver Card	118
Two Speed Motion Profiler	39	Cylinder Safety Guide	124
Motion Profiler V2 Entry	40	Offer of Sale	126

⚠ PROP 65 WARNING **WARNING:** This product can expose you to chemicals including **Lead and Lead Compounds** which are known to the State of California to cause cancer and birth defects or other reproductive harm. For more information go to www.P65Warnings.ca.gov



Introduction

The 890SD Standalone Drive is designed for speed and torque control of HAS A series Motors.

- Motor parameters are pre-loaded in drive for out of the box operation.
- Built in "valve like" operation macro for common control functions for HAS actuators.
- Available with standalone analog/discrete control or optional serial communications.

About this Manual

This manual will:

- Familiarize you with the terminals and operation of the unit.
- Provide ***basic** installation details and a set-up procedure.

** Because the 890 is a system product and we have no knowledge of your application, we detail the quickest way to power-up the drive using a simple earthing scheme with minimal control wiring. Refer to the full Engineering Reference Manual for items not covered in this document*

Provided with every HAS Drive Kit

- Pre-programmed/Tuned Drive
- Resolver terminal breakout module and 5 foot connection cable
- Motor and Feedback Cable- length set by order code
- HAS Reservoir temperature sensor and 5 meter cable
- Analog/Discrete drive include upgrade to 6901 Larger Keypad and mounting hardware

This Manual assumes that:

- You are a qualified technician with experience of installing this type of equipment.
- You are familiar with the relevant standards and Local Electric Codes (which take precedence).
- You have read and understood the Safety information provided at the front of this document.
- You realize that this guide contains only basic information and that you may need to refer to the Engineering Reference Manual to complete your installation.
- Safety Note – Use of the STO feature requires full compliance with the STO chapter 6 of the Engineering Reference Manual to which the user must first refer.

 **PROP 65 WARNING** **WARNING:** This product can expose you to chemicals including **Lead and Lead Compounds** which are known to the State of California to cause cancer and birth defects or other reproductive harm. For more information go to www.P65Warnings.ca.gov

Drive Dimensions

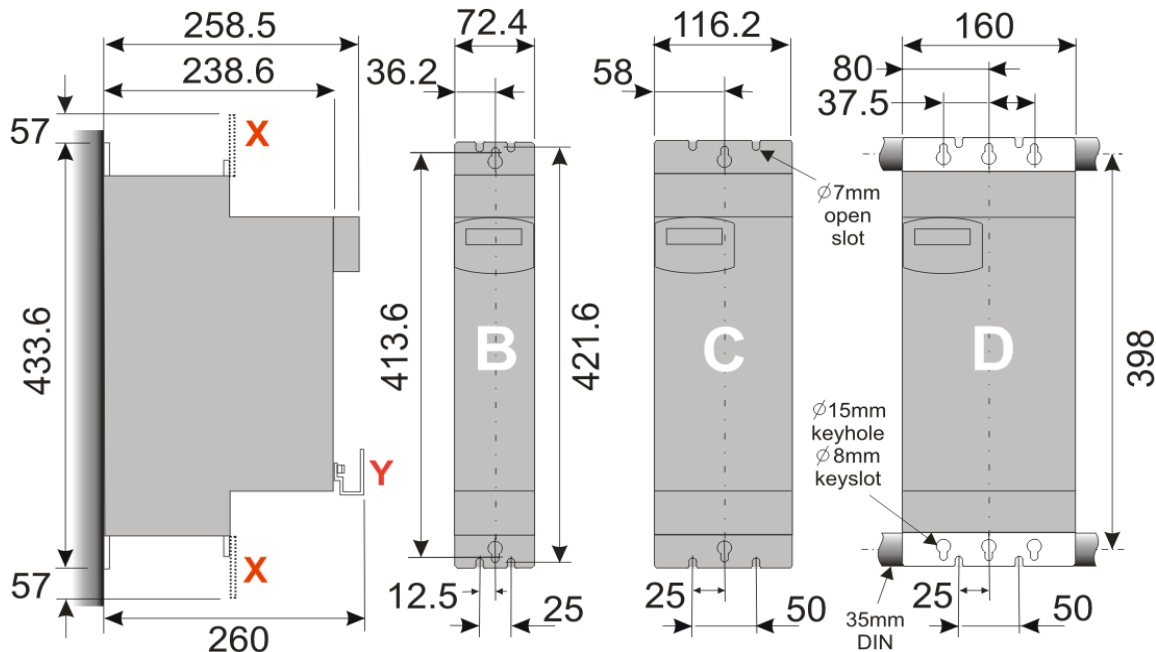

Dimensions are in millimeters (X: Power Bracket - 890 Installation Kit, Y: Control Bracket)

The units must be installed in a cubicle. Mount the drive using the keyholes and slots or on a 35mm DIN rail using the 890 Installation Kit supplied.

How to Order Drive Kits 0991760*** - XX XX - XXXX-A

Base Drive

Cable Length
 -10 = 10 FT
 -15 = 15 FT
 -25 = 25 FT
 -50 = 50 FT

Motor Configuration A09E = MPP0923D (240VAC) A09F = MPP0923R (460VAC) A10C = MPP1003C (240VAC) A10D = MPP1003R (460VAC) A11E = MPP1154B (240VAC) A11F = MPP1154P (460VAC) A14D = MPP1424R (460VAC) A14G = MPP1428Q (460VAC)

Drive kits include preprogrammed drive, power cable, feedback cable and DB15 breakout module for feedback connection.

Communications
 00 = Analog / Discrete
 IP = Ethernet IP
 IM = Modbus
 TCP CT = EtherCat

Drive Kit Number	Comon Options		Frame Size	Drive Amps	Voltage	Drive Part No
	Cable	Coms				
0991760101	00 = none	00 = Analog	B	8	230 VAC	890SD/2/0011B/B/00/A/US
0991760111	10 = 10 foot	IP = Ethernet IP	B	12	230 VAC	890SD/2/0016B/B/00/A/US
0991760122	15 = 15 foot	IM = Ethernet TCP	C	24	230 VAC	890SD/2/0024C/B/00/A/US
0991760132	20 = 20 foot		C	30	230 VAC	890SD/2/0030C/B/00/A/US
0991760201	25 = 25 foot		B	4	380-500 VAC	890SD/5/0006B/B/00/A/US
0991760211	50 = 50 foot		B	6	380-500 VAC	890SD/5/0010B/B/00/A/US
0991760221	XX = custom		B	10	380-500 VAC	890SD/5/0016B/B/00/A/US
0991760301			C	20	380-500 VAC	890SD/5/0024C/B/00/A/US
0991760312			C	25	380-500 VAC	890SD/5/0030C/B/00/A/US
0991760322			D	29	380-500 VAC	890SD/5/0039D/B/00/A/US

▲ PROP 65 WARNING WARNING: This product can expose you to chemicals including **Lead and Lead Compounds** which are known to the State of California to cause cancer and birth defects or other reproductive harm. For more information go to www.P65Warnings.ca.gov

Installation

A simplified installation is shown below. The installation is not EMC complaint. For European installations and countries with EMC legislation refer to the 890 Engineering Reference Manual Appendix C.

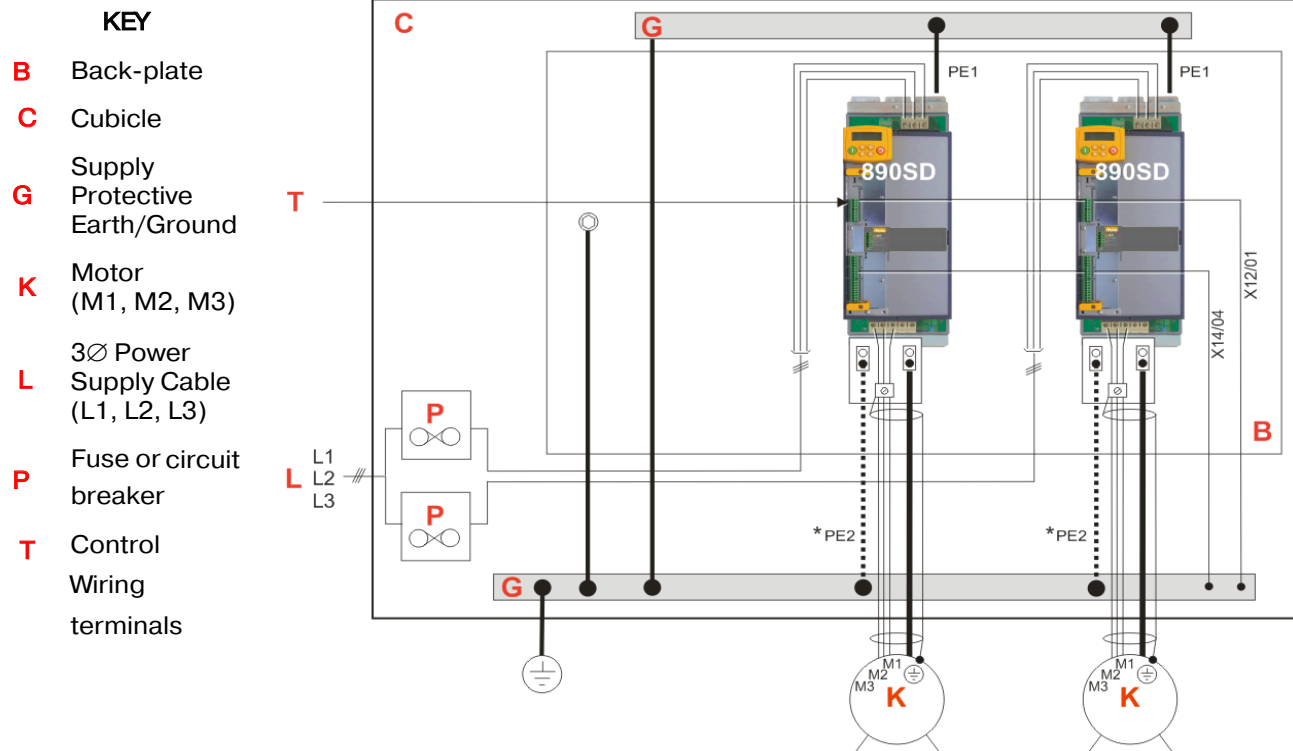

Ventilation

The drives can be mounted side-by-side with no clearance. A minimum of 150mm (6 inches) free-air space must be allowed at the top and bottom of each drive. If mounting drives above or below other equipment, the top and bottom distances should be added for overall clearance between drives.

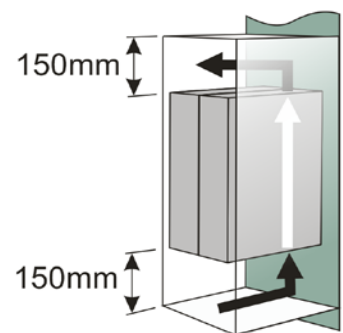

Environmental Conditions

Operating ambient	0°C to 45°C (32°F to 113°F)
temperature Enclosure rating	IP20 – UL(cUL) Open type
Atmosphere	Dust free, non flammable, non-corrosive, <85% humidity, non-condensing

⚠ PROP 65 WARNING **WARNING:** This product can expose you to chemicals including **Lead and Lead Compounds** which are known to the State of California to cause cancer and birth defects or other reproductive harm. For more information go to www.P65Warnings.ca.gov

The 890 Installation Kit is supplied with your unit. The kit provides several options for earth/ground connections. It also includes the brackets for DIN rail mounting the unit. Refer to the instructions in the kit and use the appropriate parts.

Cables are considered to be electrically sensitive, clean or noisy. Plan your cable routes to segregate these cables for EMC compliance. Refer to Appendix C: "Certification".

Panel Mount Fixings

Support the unit at the top and bottom with fixings to secure the unit to the panel. Mark and drill the fixing holes into the panel. Refer to the fixing centers given on the previous page. Insert the fixings into the top hole(s) and hang the unit. Insert the bottom fixing(s) and tighten to the required torque.



DIN Rail Mounting

The unit can be DIN rail mounted (35mm DIN). Convert the unit to accept to DIN rail mounting:

1. Secure the DIN clips from the 890 Installation Kit into the threaded inserts at the top of the unit using the fixings supplied.
2. Hang the unit on the top DIN rail. Fix the DIN clips onto the bottom of the unit and clip onto the DIN rail.
3. Tighten both the top and bottom clips when the unit is in position on the rail.



Shield Bonding Clips

Fit the shield bonding clips to the Control Bracket/Power Bracket. Select slots providing a loose fit. This will then allow the clips to be tightened by hand.

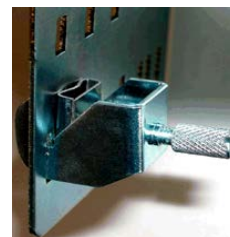

Note Do not squeeze the clip sides to produce a fit as this will crimp the sides to the clip's moving soleplate.

▲ PROP 65 WARNING **WARNING:** This product can expose you to chemicals including **Lead and Lead Compounds** which are known to the State of California to cause cancer and birth defects or other reproductive harm. For more information go to www.P65Warnings.ca.gov



F : Shield Bonding Clips
 For larger sizes contact SSD Drives.
 Part Numbers:
 CI465892U014 - 14mm Ø
 CI465892U020 - 20mm Ø

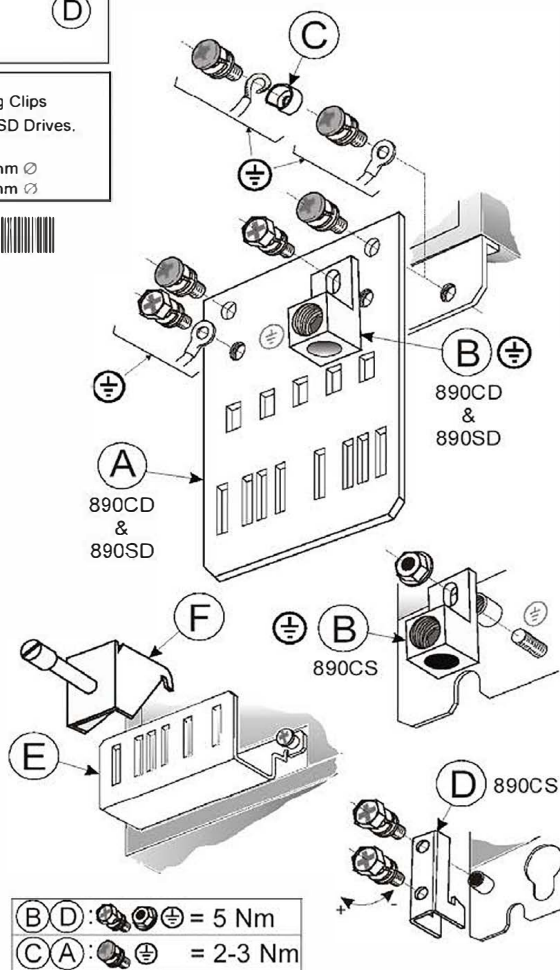

B D : = 5 Nm
C A : = 2-3 Nm

890 Installation Kit

Item	Description	SSD Part Number	Qty
890CS : Common Bus Supply			
B	Ground Terminal M6 small	CI465312	1
	Ground Terminal M6 large	CI470521U001	1
C	Cup Washer M5	FX463522	2
D	DIN Clip	BA465900	4
E	Control Bracket	BA465887	1
	Screw Assembly M4 x 10mm	FY385649	2
	Screw Assembly M5 x 12mm	FY468470U012	8
	Nut Assembly	FZ463232	1
	Busbar Insulation 15mm	BC465938U015	2
	Busbar Insulation 200mm	BC465938U200	1
F	Shield Bonding Clip 8mm Ø	CI465892U008	1
	Screwdriver	JA465841	1
	Allen Wrench	JA465842	1
890CD : Common Bus Drive			
A	Power Bracket	BA465888	1
B	Ground Terminal M6	CI465312	1
C	Cup Washer M5	FX463522	2
D	DIN Clip	BA465900	4
E	Control Bracket	BA465887	1
	Screw Assembly M4 x 10mm	FY385649	4
	Screw Assembly M5 x 12mm	FY468470U012	10
	Busbar Insulation 200mm	BC465938U200	1
F	Shield Bonding Clip 8mm Ø	CI465892U008	1
	Terminal Wiring Label	GA469181	1
890SD : Standalone Drive			
A	Power Bracket	BA465888	2
B	Ground Terminal M6	CI465312	2
C	Cup Washer M5	FX463522	2
D	DIN Clip	BA465900	4
E	Control Bracket	BA465887	1
	Screw Assembly M4 x 10mm	FY385649	4
	Screw Assembly M5 x 12mm	FY468470U012	10
F	Shield Bonding Clip 8mm Ø	CI465892U008	1
	Screwdriver	JA465841	1
	Terminal Wiring Label	GA469181	1

PROP 65 WARNING WARNING: This product can expose you to chemicals including **Lead and Lead Compounds** which are known to the State of California to cause cancer and birth defects or other reproductive harm. For more information go to www.P65Warnings.ca.gov



 **PROP 65 WARNING** **WARNING:** This product can expose you to chemicals including **Lead and Lead Compounds** which are known to the State of California to cause cancer and birth defects or other reproductive harm. For more information go to www.P65Warnings.ca.gov



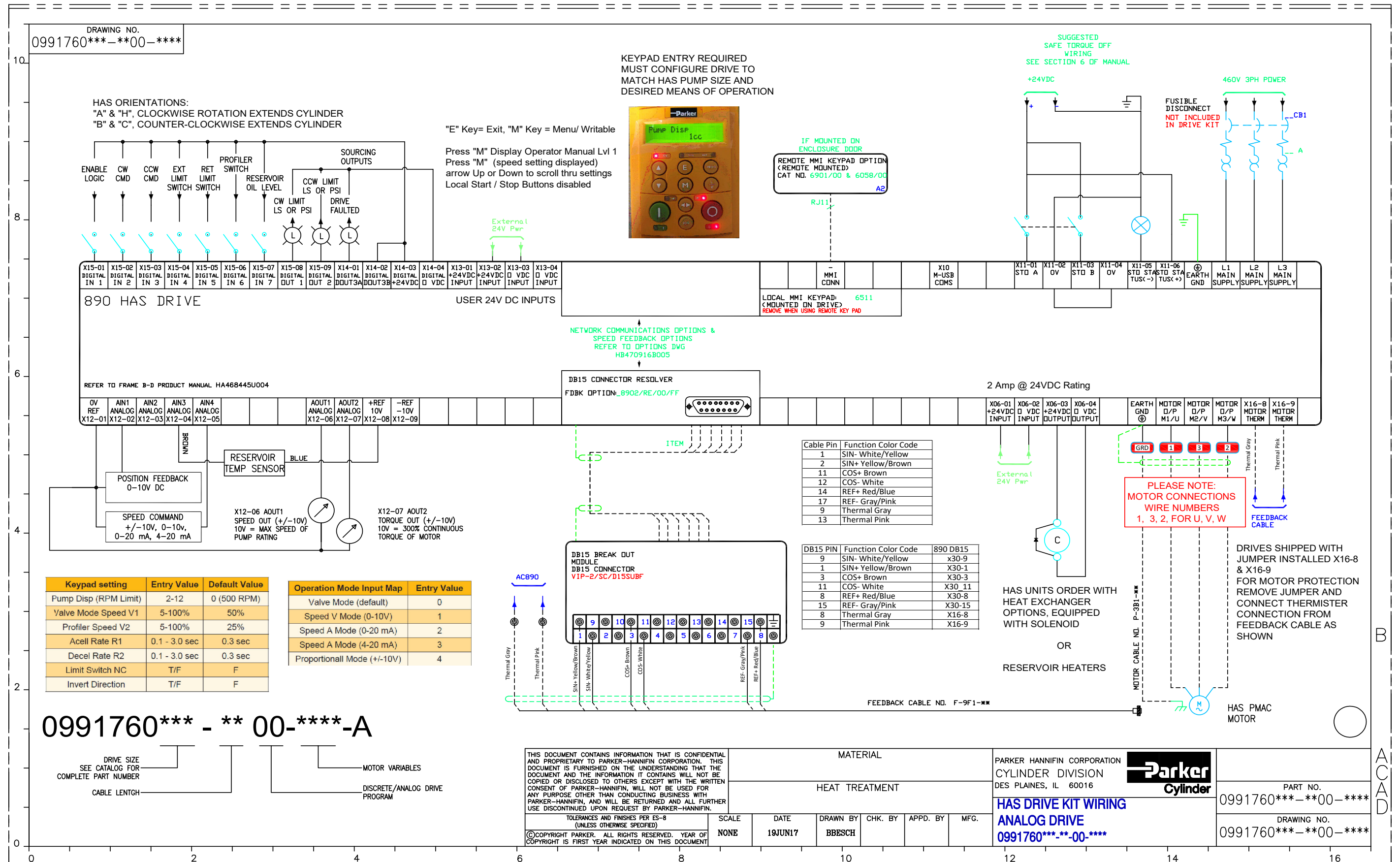

Overview

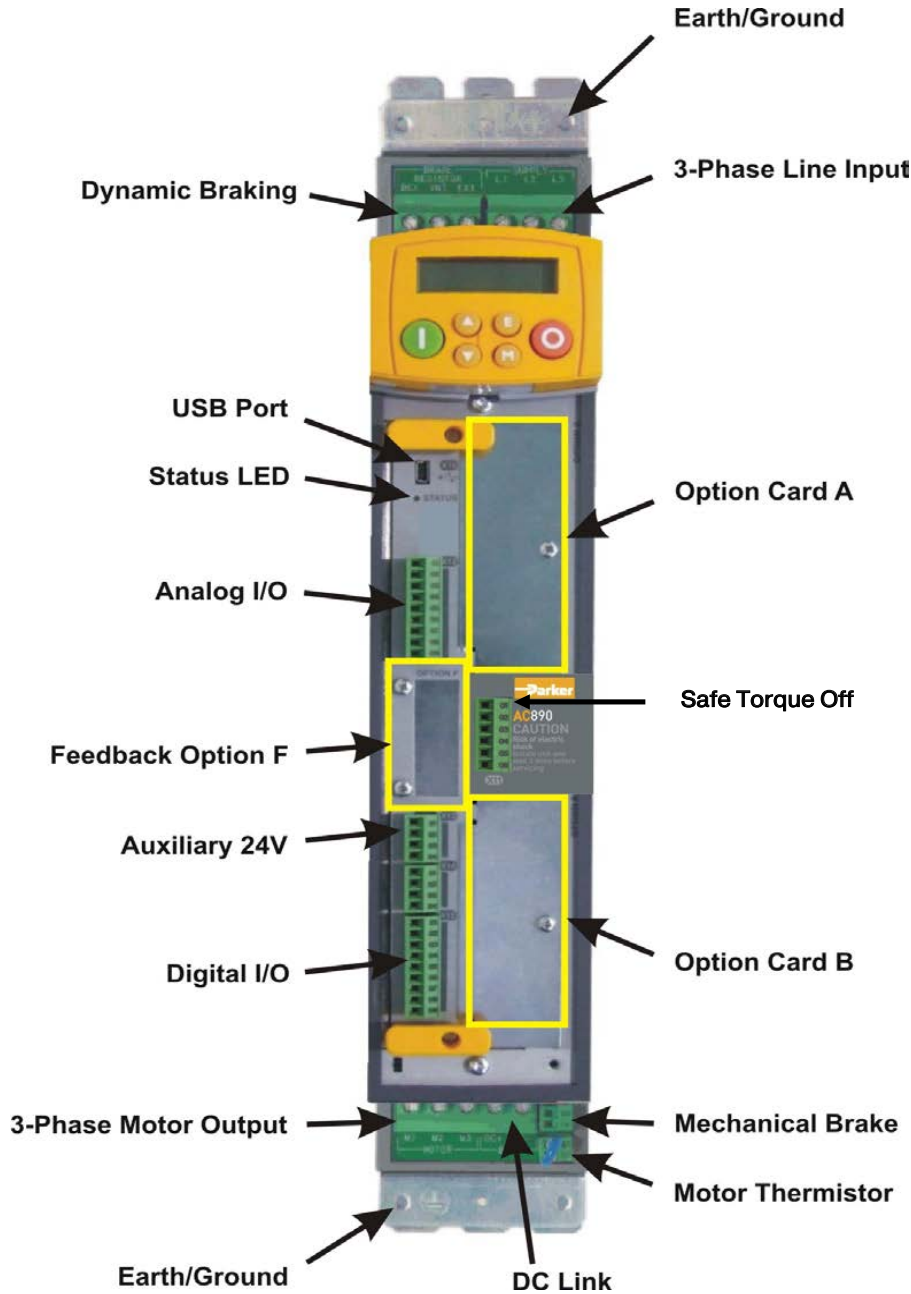

⚠ PROP 65 WARNING **WARNING:** This product can expose you to chemicals including **Lead and Lead Compounds** which are known to the State of California to cause cancer and birth defects or other reproductive harm. For more information go to www.P65Warnings.ca.gov



HAS AC890 Control Connections Overview

A Keypad

Shown with standard keypad, visual display of operation and setup of key parameters for HAS operation

B Analog

Analog Inputs and outputs for controlling and displaying HAS Speed Position and Temperature

See section __ for more details

C HAS Motor Feedback

Sub D15 Connector:

- Connect Sub D15 Cable from breakout module

D Inputs power supply

Built in 24V Power supply for input device connections.
Terminal X13, Pins 1 thru 4.

E Discrete Control

Discrete input and outputs for controlling HAS basic operation

See section __ for more details

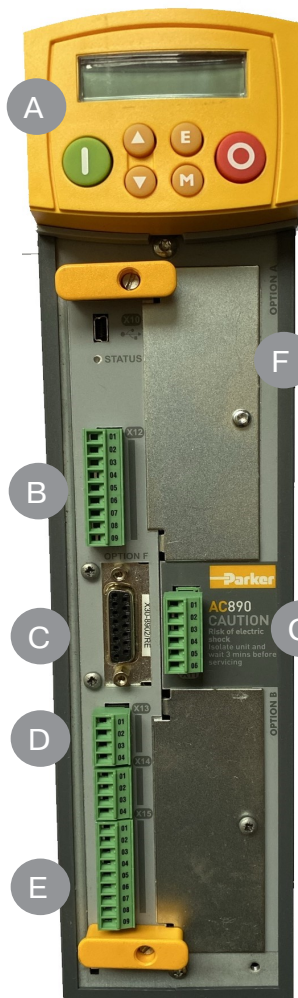

The control terminals will accept a single wire of size 1.5mm²/16AWG. For two wires per terminal, use smaller gauge wire such as 0.5mm²/22AWG.

F Network Coms Slot

Discrete I/O Drive Shown, no network communication card shown.

G Safe Torque Off

To disable STO:

- Connect X14/03 to X11/01 and X11/03
- Connect X14/04 to X11/04

To use the STO feature the user must read and fully understand chapter 6 of the Engineering Reference Manual.

Earth/ground plate for terminating all control wiring shields

PROP 65 WARNING WARNING: This product can expose you to chemicals including **Lead and Lead Compounds** which are known to the State of California to cause cancer and birth defects or other reproductive harm. For more information go to www.P65Warnings.ca.gov

3-Phase Connections

1 Connect 3-phase power in any order to L1, L2, L3.
Maximum wire sizes:
Frame B: 6mm²/10AWG - 0.5Nm
Frame C: 10mm²/8AWG - 1.2Nm
Frame D: 16mm²/4AWG - 2.4Nm

- Use branch circuit protection (circuit breaker and/or fuses)

Refer to Appendix D for Drive Rating details

2 Connect the earth/ground wire to the top ground bracket. Maximum wire sizes:
Frame B: 6mm²/10AWG
Frame C: 10mm²/8AWG
Frame D: 16mm²/4AWG

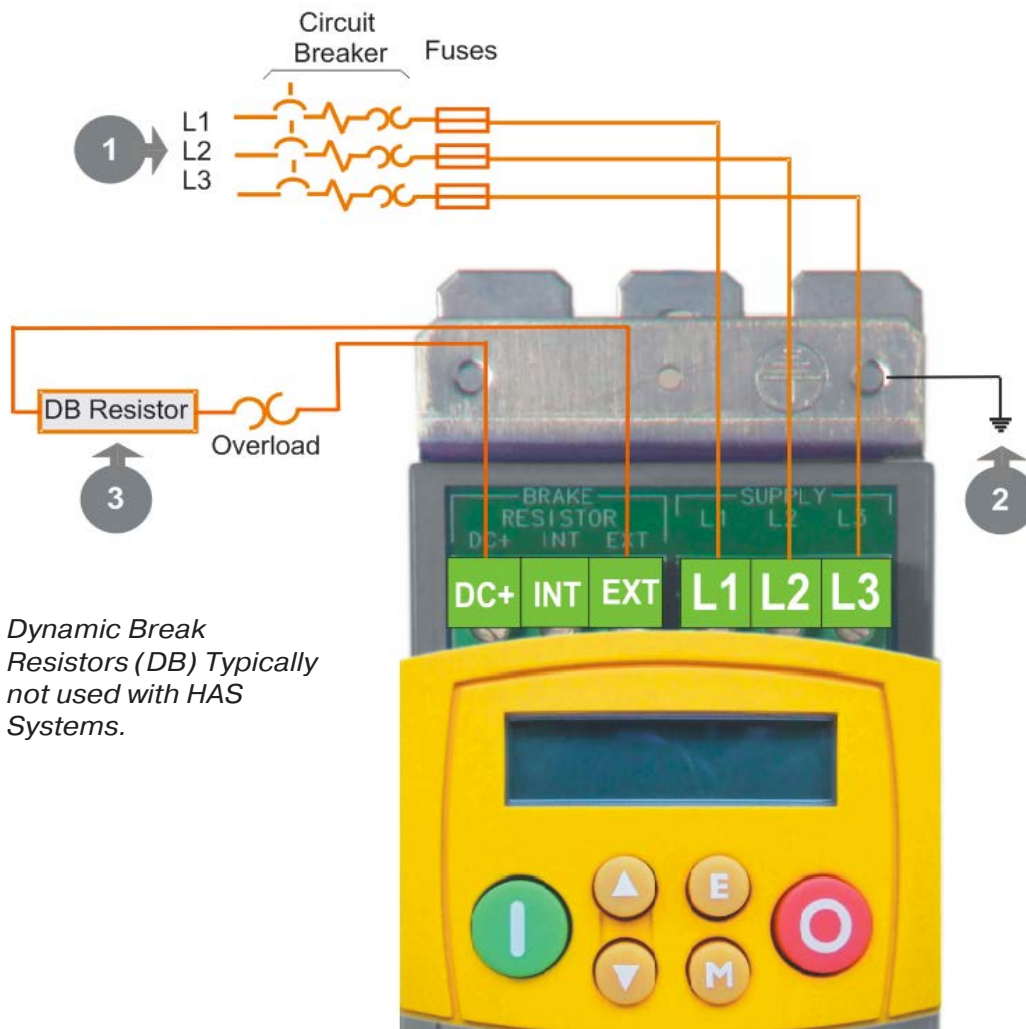

Dynamic Break Resistors (DB) Typically not used with HAS Systems.

⚠ PROP 65 WARNING **WARNING:** This product can expose you to chemicals including **Lead and Lead Compounds** which are known to the State of California to cause cancer and birth defects or other reproductive harm. For more information go to www.P65Warnings.ca.gov

Motor Connections

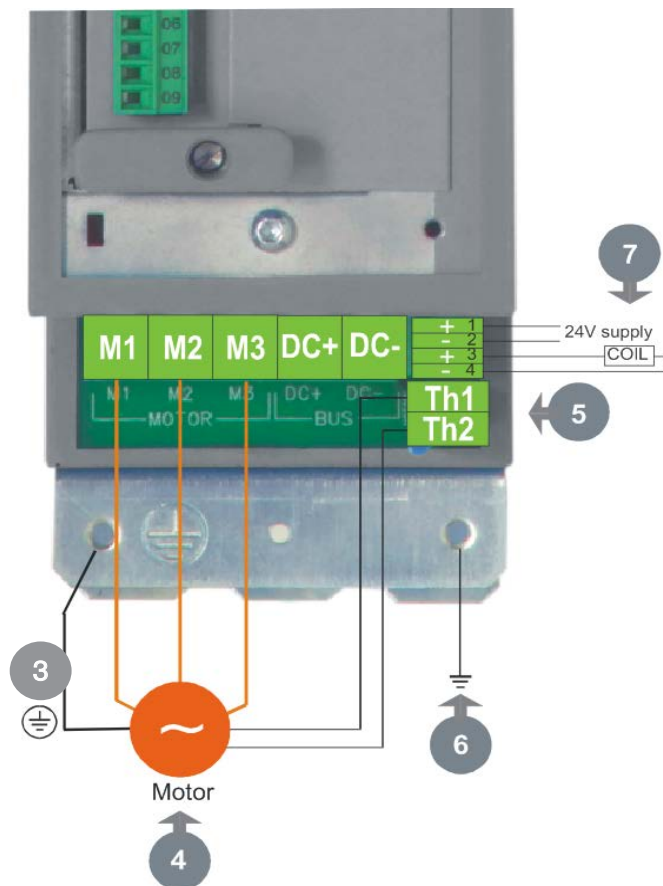

4 Connect motor leads to M1, M2, M3. Maximum wire sizes:
Frame B: 4mm²/12AWG **Frame C: 10mm²/8AWG** **Frame D: 16mm²/4AWG**

Motor cable wire numbering
#1 connect to M1
#3 connect to M2
#2 connect to M3

3 Connect the earth/ground wire from the terminal box of the motor directly to the bottom ground bracket. Maximum wire sizes: **Frame B: 4mm²/12AWG** **Frame C: 10mm²/8AWG** **Frame D: 16mm²/4AWG**

- If not using shielded cable, run motor leads in an enclosed metal conduit grounded at both ends

6 Connect the earth/ground wire to the bottom ground bracket. Maximum wire sizes: **Frame B: 4mm²/12AWG** **Frame C: 10mm²/8AWG** **Frame D: 16mm²/4AWG**

5 Connect motor thermal switch or thermistor to Th1, Th2. (X16 -Pin 8 and 9) Drive will trip when the thermal switch opens, or when the thermistor resistance exceeds 4kΩ maximum (PTC Type A : IEC 34-11 Part 2)

7 Connection when HAS Unit is fitted for Heat Exchanger Option. Coil use to activate relay controlling Fan or water Valve.

⚠ PROP 65 WARNING **WARNING:** This product can expose you to chemicals including **Lead and Lead Compounds** which are known to the State of California to cause cancer and birth defects or other reproductive harm. For more information go to www.P65Warnings.ca.gov

HAS Cable Connections

Motor Feedback Cable

The default motor feedback for HAS A series motor is a Resolver. This device is used to provide feedback of the motor speed to provide closed loop control of HAS motor.

A Series Motors PS series connectors feature TE Connectivity Interconnection circular connectors mounted to the motor body. These connectors are right angle mount and can be fully rotated. This allow greater cable routing options.

The supplied Feedback cable is a flying lead, 17 conductor cable. Not all conductors are used.

Included in the HAS Drive Kit is a Sub DB15 breakout module and mating 5 foot cable. This module features wire connection terminations for the feedback cable, while allowing easy connection to the Drive.

A series Motors are equipped with temperature monitoring sensor and connections is located in the feedback cable. The break out module allows the installer to connect the Pink and Gray wires to connector X16, pins 8 and 9 located on the bottom of the drive. It is also labeled as TH1, T2. Wire polarity does not matter.

The drives are shipped with a jumper connected X16 pin 8 and 9, this jumper must be removed to thermally protect the motor from overload condition.

Motor Power Cable

The supplied power cable consist of a flying lead, 6 conductor cable.

It is important to connect the U, V and W phase wires correctly. In correct wiring will cause the HAS motor to lock up pulling full current

- Cable Wire # 1 (U) connects to M1 on drive**
- Cable Wire # 3 (V) connects to M2 on drive**
- Cable Wire # 2 (W) connects to M3 on drive**

The default motor for options for HAS unit do not include a brake assembly. HAS units use traditional hydraulic means for load holding. The Brake actuation wires are located in the power Cable. These wire have no connection and are not needed. **Follow Grounding practices listed on page 7**

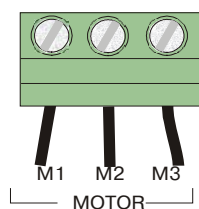

M1 (U), M2 (V), M3 (W).
 Maximum wire sizes:

Frame B: 6mm² / 10AWG, 0.8Nm / 0.6ft-lbf
 Frame C: 10mm² / 8AWG, 1.7Nm / 1.25ft-lbf



Power Cable		
Pin No	Color	Function
1	Blk # 1	Phase U
2	Blk # 2	Phase W
6	Blk # 3	Phase V
3	Grn/Yel	Ground
4	Red/Blu	**Brake
5	Red/Blu	**Brake

Wire Color Pin Outs		
Feedback Cable		
Pin No	Color	Function
1	Yellow/Brown	Sin +
9	White/Yellow	Ref Sin
8	Red/Blue	+ 5V
15	Gray/Pink	Grd
11	White	Ref Cos
3	Brown	Cos +
TH-1	Pink	Temp
TH2	Gray	Temp +

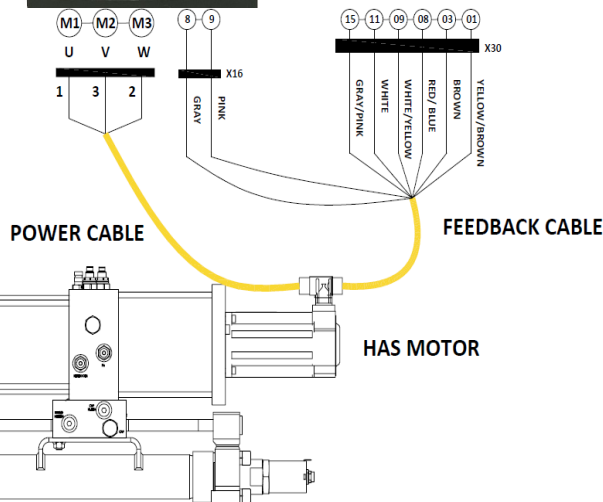

PROP 65 WARNING WARNING: This product can expose you to chemicals including **Lead and Lead Compounds** which are known to the State of California to cause cancer and birth defects or other reproductive harm. For more information go to www.P65Warnings.ca.gov

HAS Cable Connections to Motors

Motor Connector Technical Data	
Housing	Nickel-plated Zinc
Coupling Nut	Nickel-plated Zinc
Insulation Insert	PBT UL94/VO
Contacts	Gold Plated Brass
Sealing	FKM Viton Fluorocarbon Rubber
Clamp Ring	Nickel-plated Zinc
Temperature Rang	Standard: -4 to 266 F
Rotation Angle	330 degrees
Mating Cycles	500

A09* and A10* Motor Power Connector	
Motor Connector	Intercontec BEDC106MR14001216000
Connector Kit*	PS-CONN-KIT

A Series Motor Feedback Connector	
Motor Connector	Intercontec AEDC139MR04001215000
Connector Kit*	0993060000

A11* and A14* Motor Power Connector	
Motor Connector	Intercontec BEDC106MR43001216000
Connector Kit*	0993060000

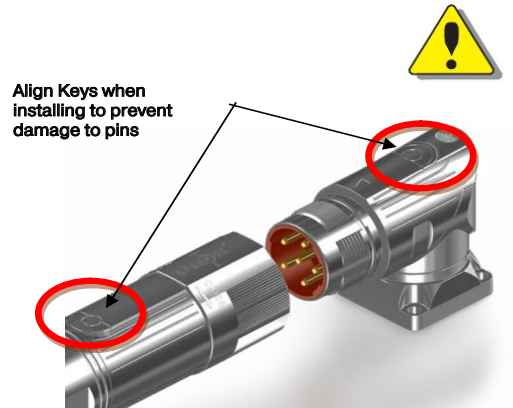

Mating Cables: IP66/IP67 protection ratings according to EN 60529

Cable Part No	Drive Kit Number	RMS Amp Rating	Outer Jacket	Size	Bend Radius	Temp	Motor Series
P-3B1-xxx	0991760 **1	20	PVC	0.485"	3.88"	-20-105 C	A09* ~ A10*
P-4B1-xxx	0991760 **2	30	PVC	0.445"	3.56"	-20-105 C	A10* ~ A14*

PROP 65 WARNING WARNING: This product can expose you to chemicals including **Lead and Lead Compounds** which are known to the State of California to cause cancer and birth defects or other reproductive harm. For more information go to www.P65Warnings.ca.gov

HAS Drive Setup-Using the Keypads

The 890 units are factory fitted with the 6511 Keypad. To remove it, simply pull it away from the drive. This will expose the mating RJ11 connector for the 6901 keypad. To refit it, push it back into place.

HAS Drive Analog Drive kits are upgraded with 6901 Keypad. This keypad provides more character for analog setup.

Both the 6511 and 6901 Keypad can be mounted up to 3 meters away from the 890 using the optional panel mounting kit with connecting lead: refer to "Remote Mounting the Keypad", page 4

The 6901 Keypad connects to the drive with a RJ11 3 foot cable included with drive kit.



6901



6511

Minimum Setup Requirements

1. Install drive in suitable enclosure, ensure environmental requires are met. (page 7)
2. Wire per state and local requirements, wiring details found on drawing number: 0991760_ _00-XXX-A. (page 12)
3. Set Pump Displacement in Drive (page 28)
4. Determine Type of Operation needed (page 31)
 - a. Basic Directional Control (page 32)
 - b. Soft-shift ramp control (Page 35-36)
 - c. Motion Profiler / 2-speed control (page 40)
 - d. Speed and Direction with analog input (page 41)
 - e. Proportional Control (page 44)

⚠ PROP 65 WARNING **WARNING:** This product can expose you to chemicals including **Lead and Lead Compounds** which are known to the State of California to cause cancer and birth defects or other reproductive harm. For more information go to www.P65Warnings.ca.gov

6511 Keypad Operation

The 6901 Keypad (Man-Machine Interface, MMI) provides for local monitoring of the drive. It is useful for display of speed percentage and faults. It is not recommended for setting up the Discrete Analog Drive configurations. The 6511 should be removed and 6901 should be used for setup purposes.

To display the Software Version:

Press and hold **E** to display software version. Time-out or press **M**.

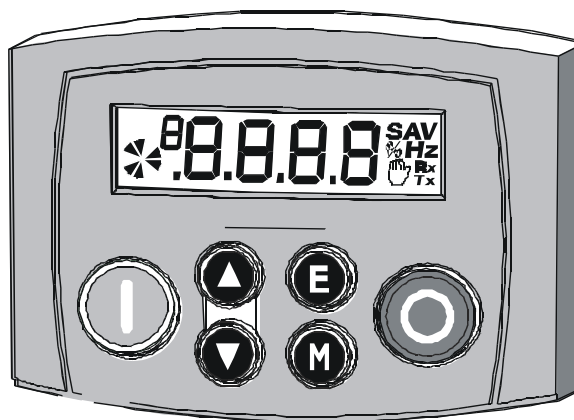

Initial Power-Up Conditions

The keypad will display the Operator menu Drive and 890SD Standalone Drive.

OP I (Operation Menu)

A when displaying an Alarm code a
 - negative parameter value

Displays the units for the value:

V for voltage in Volts, for A for current in Amps
 Hz frequency in Hertz for % for percentage
 S seconds

Indicates the Control Mode



Represents a rotating shaft: clockwise = drive running forward anticlockwise - drive running in reverse

Indicates the drive is in Remote Comms mode

Indicates the drive is in Local control. *Drive is in remote control when not visible.*

Indicates numbers or values, trip information, error codes etc. See "Status Indications" below.

PROP 65 WARNING WARNING: This product can expose you to chemicals including **Lead and Lead Compounds** which are known to the State of California to cause cancer and birth defects or other reproductive harm. For more information go to www.P65Warnings.ca.gov

6511 Menu System



The Keypad will display the Operator Menu. Each menu contains parameters.

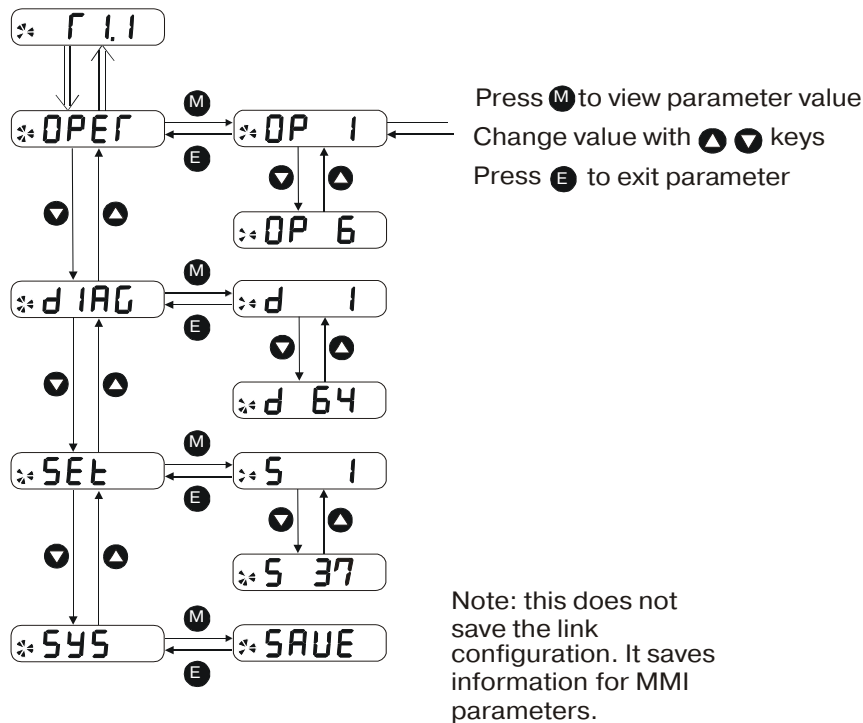
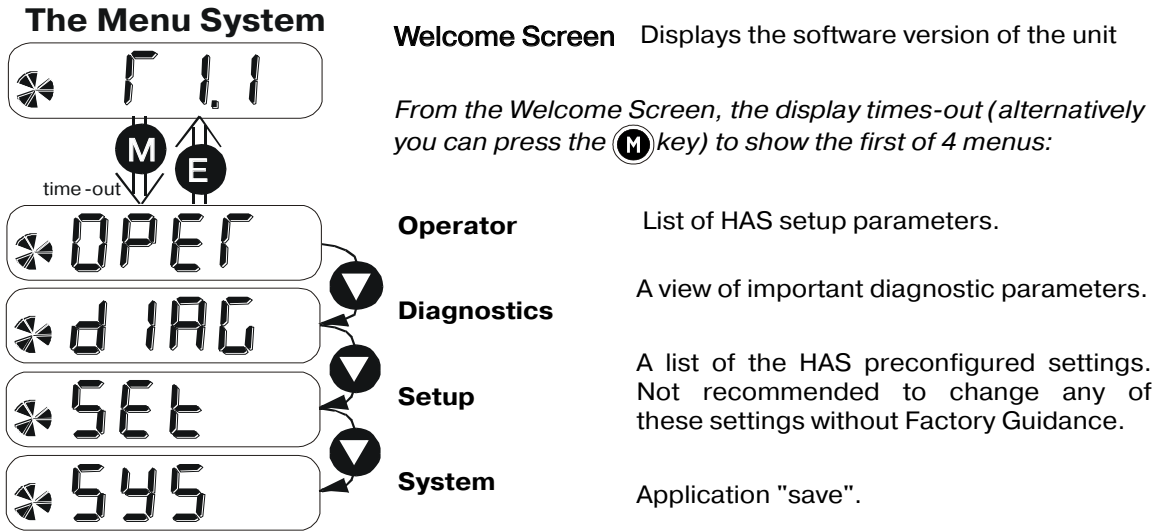

PROP 65 WARNING WARNING: This product can expose you to chemicals including **Lead and Lead Compounds** which are known to the State of California to cause cancer and birth defects or other reproductive harm. For more information go to www.P65Warnings.ca.gov

6511 Keypad Control Key Definitions



Key	Operation	Description
	Escape	<i>Navigation</i> - Moves upwards through the list of parameters. <i>Parameter</i> - Increments the value of the displayed parameter. <i>Command Acknowledge</i> - Confirms action when in a command menu.
	Menu	<i>Navigation</i> - Moves downwards through the list of parameters. <i>Parameter</i> - Decrements the value of the displayed parameter.
	Increment	<i>Navigation</i> - Displays the previous level's Menu. <i>Parameter</i> - Returns to the parameter list. <i>Trip Message</i> - Clear the Trip or Error message from the display.
	Decrement	<i>Navigation</i> - Displays the next Menu level, or the first parameter of the current Menu. <i>Parameter</i> - Allows a writable parameter to be modified (this is indicated by → appearing on the left of the bottom line).

⚠ PROP 65 WARNING **WARNING:** This product can expose you to chemicals including **Lead and Lead Compounds** which are known to the State of California to cause cancer and birth defects or other reproductive harm. For more information go to www.P65Warnings.ca.gov

6901 Keypad Operation

The 6901 Keypad (Man-Machine Interface, MMI) provides for easy setup of pre-programmed HAS drive kits. It will also display faults and operating conditions of the unit.

To display the Programmed Version:

Press and hold **E** to display software version. Time-out or press **M**.

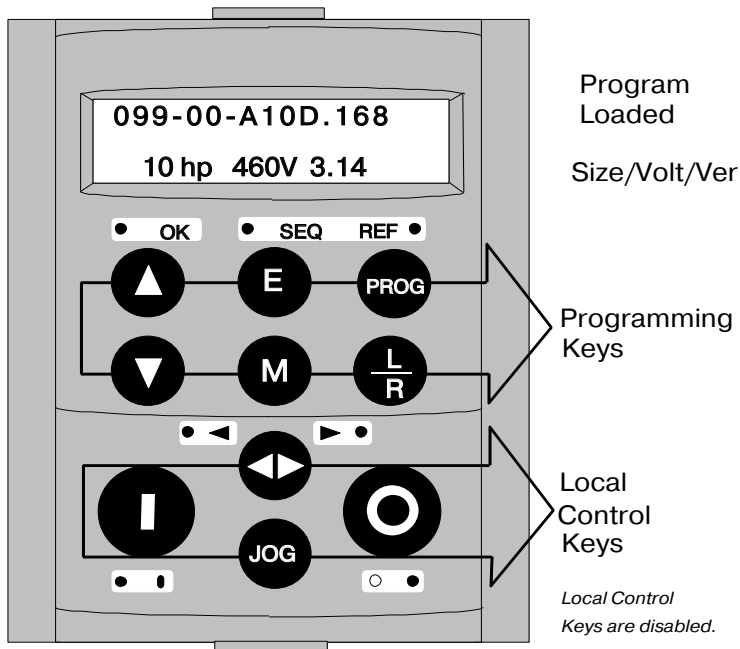

Identifying a Programmed Drive

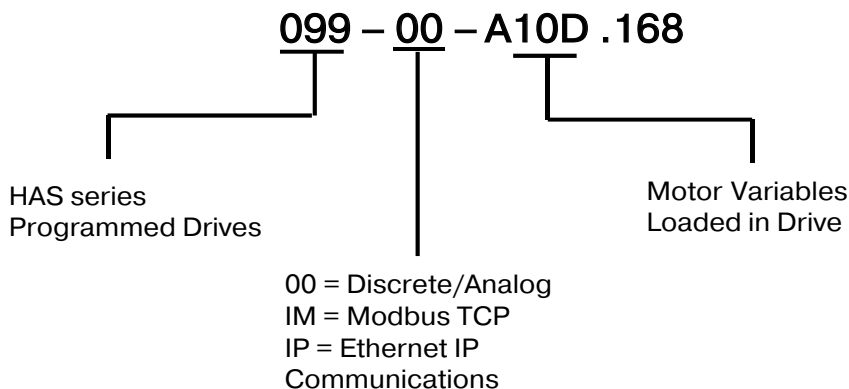

⚠ PROP 65 WARNING **WARNING:** This product can expose you to chemicals including **Lead and Lead Compounds** which are known to the State of California to cause cancer and birth defects or other reproductive harm. For more information go to www.P65Warnings.ca.gov



6901 Keypad Operation

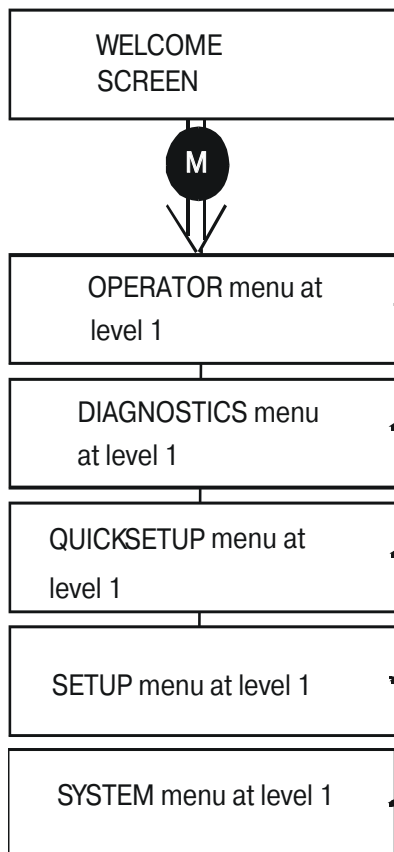

Welcome Screen

Displays the software version of the unit

*From the Welcome Screen, the display times-out (alternatively you can press the **M** key) to show the first of 4 menus:*

Operator

A view of HAS settings and diagnostic parameters

Diagnostics

A view of general diagnostic parameters

Quick Setup

Not applicable for HAS Operation

Setup

Function blocks parameters drive advanced configuration. Not recommended for Alteration without factory guidance

System

Application "save" and macro selection.

Navigating the Menu System

On power-up, the Keypad defaults into the OPERATOR menu, timing out from the Welcome screen. You can skip the timeout

by pressing the **M** key immediately after power-up which will take you directly to the OPERATOR menu.

The menu system can be thought of as map which is navigated using the four keys shown opposite.

Keys **E** and **M** navigate through the menu levels.
 The up (▲) and down (▼) keys scroll through the Menu and Parameter lists.

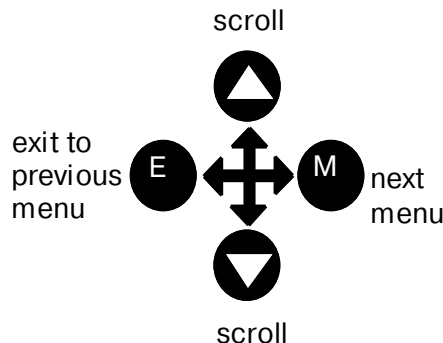





Refer to "The Menu System Map" to see how the full menu is mapped.

▲ PROP 65 WARNING **WARNING:** This product can expose you to chemicals including **Lead and Lead Compounds** which are known to the State of California to cause cancer and birth defects or other reproductive harm. For more information go to www.P65Warnings.ca.gov

6901 Keypad Control Key Definitions



UP 	<i>Navigation</i> - Moves upwards through the list of parameters or menus <i>Parameter</i> - Increments the value of the displayed parameter. <i>Command Acknowledge</i> - Confirms action when in a command menu.
DOWN 	<i>Navigation</i> - Moves downwards through the list of parameters or menus <i>Parameter</i> - Decrements the value of the displayed parameter.
ESCAPE 	<i>Navigation</i> - Displays the previous level's Menu. <i>Parameter</i> - Returns to the parameter list. <i>Trip Message</i> - Clear the Trip or Error message from the display.
MENU 	<i>Navigation</i> - Displays the next Menu level, or the first parameter of the current Menu. <i>Parameter</i> - Allows a writable parameter to be modified (this is indicated by → appearing on the left of the bottom line). Hold to display the PREF.
PROG 	<i>Navigation</i> - Toggles between current locations within the Operator menu and any other menu.

The PROG Key

The **PROG** key toggles between the OPERATOR menu and any other menu, remembering and returning to previous positions in each menu. As you press the **PROG** key, the title of the menu you are about to enter is displayed, i.e. OPERATOR or for example DIAGNOSTICS. Releasing the key clears the display and releases you into that menu.

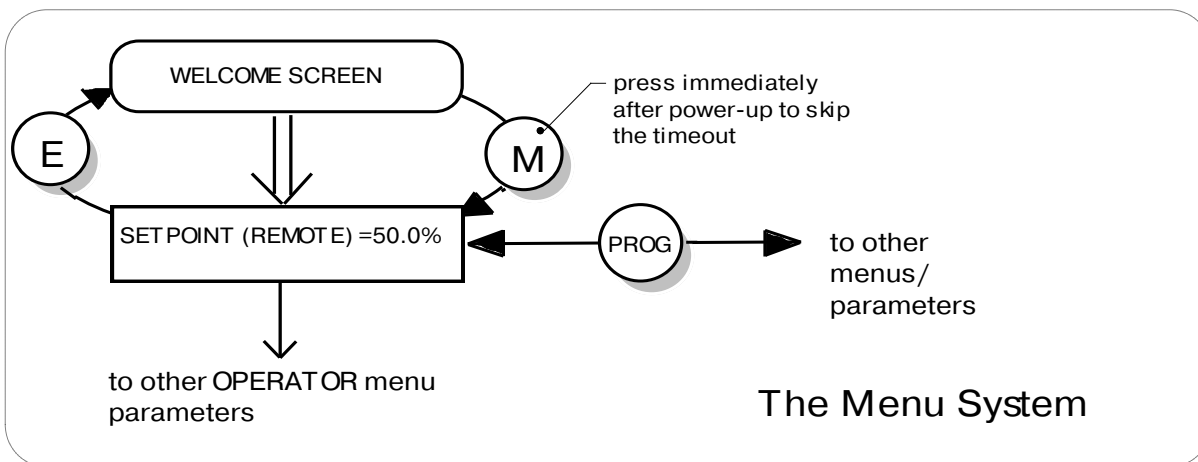

⚠ PROP 65 WARNING **WARNING:** This product can expose you to chemicals including **Lead and Lead Compounds** which are known to the State of California to cause cancer and birth defects or other reproductive harm. For more information go to www.P65Warnings.ca.gov



6901 Keypad Installation

The 6052 Mounting Kit is included in the HAS drive Kit. An enclosure rating of IP54 is achieved for the remote Keypad when correctly mounted using the 6052 Mounting Kit.

6052 Mounting Kit Parts for the Remote Keypad

Tools Required

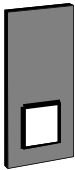
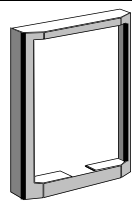
No. 2 Posidrive screwdriver.

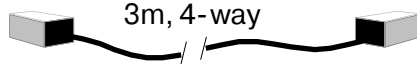
6052 Mounting Kit			
1		1	
4	 No. 6 x 12mm	1	 3m, 4-way

Assembly Procedure

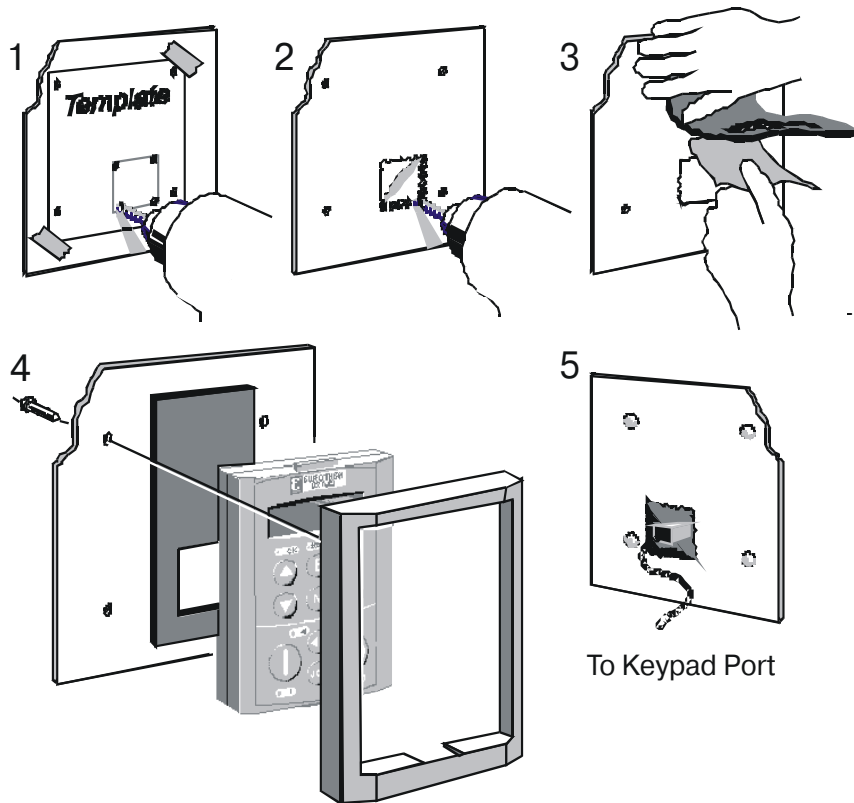

Template

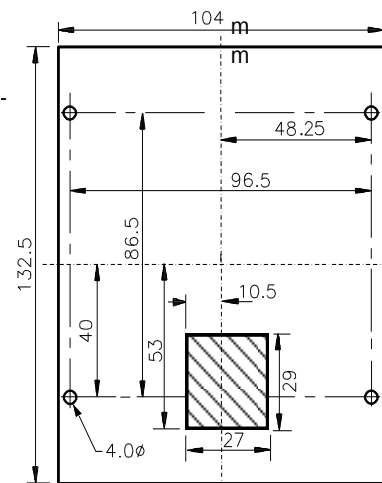

⚠ PROP 65 WARNING WARNING: This product can expose you to chemicals including **Lead and Lead Compounds** which are known to the State of California to cause cancer and birth defects or other reproductive harm. For more information go to www.P65Warnings.ca.gov

Dump Displacement - Entry

Obtain Pump Displacement from HAS Model Code

Default Setting: 1

Value of "1" is a None Valid setting resulting in limiting pump speed to a maximum of 1000 RPM.

Field is not Password Protected

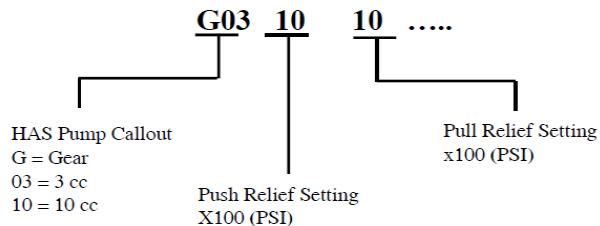

Incorrect values may cause pump cavitation and damage unit, ensure proper selection of displacement

To SET Pump displacement from Home Screen

Press **M** to display OPERATOR Menu at Level 1

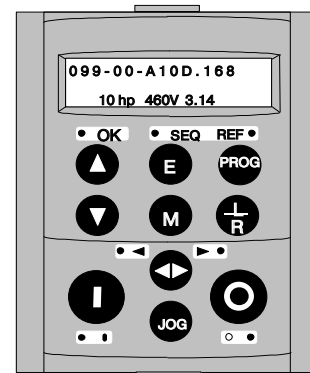

Home Screen

Press **▼** to scroll to Pump Displacement Page



Operator Menu Screen

Press **M** to enable entry

-> will be displayed on left of entry **▲ ▼**
 indicating active for increasing/decreasing pump size.

Press **▲ ▼** until proper value is set.

When correct, press **E**

Press **E** to return up one level

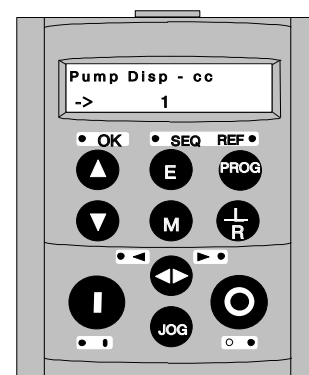

Operator Menu - Pump Disp

▲ PROP 65 WARNING **WARNING:** This product can expose you to chemicals including **Lead and Lead Compounds** which are known to the State of California to cause cancer and birth defects or other reproductive harm. For more information go to www.P65Warnings.ca.gov

HAS External 24V Input Wiring

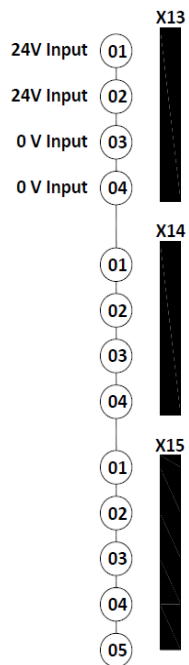

Connection can be made from a suitable, external 24V source. This 24V DC control supply allows for configuration and commissioning of the system without the AC supply being present. The drive will operate with this supply but will not turn a motor.

Connection is not required when the AC supply is present, but the connection can be safely left connected.

You can connect up to four 890SD units in total when daisy-chaining 24V using these terminals (8A maximum).

PROP 65 WARNING WARNING: This product can expose you to chemicals including **Lead and Lead Compounds** which are known to the State of California to cause cancer and birth defects or other reproductive harm. For more information go to www.P65Warnings.ca.gov

Input Overview

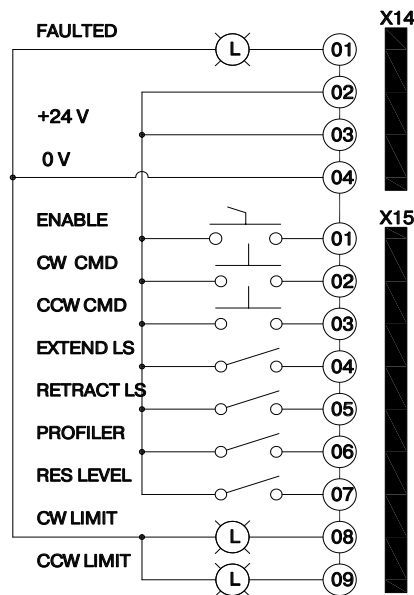

Enable (Input)

When True (High) drive will react to other discrete inputs. When False (Low) inputs are ignored.

CW CMD (Input)

When True (High) drive will spin the pump in a clockwise function. HAS Speed is set by the V1 setting on keypad setup, see Page 22 for details.

The HAS orientation call out in the model code set the extend and retract direction. Orientations "A" & "H" (reservoir on Cap end) CW rotation Extend Cylinder, "B" & "C" (Reservoir on Head end) CCW rotation extends the cylinder. Orientation can be inverted through keypad entry see page 21

CCW CMD (input)

When True (High) drive will spin the pump in a counterclockwise function. HAS Speed is set by the V1 setting on keypad setup, see Page 22 for details.

End of Stroke Limit Switches

If desired, end of stroke limit switches maybe used with HAS Programmed Drives. Default setting is for Normally Open type switches, Setting to Normally Closed is done through Key Pad entry see page 25 for more details

Extend LS (Input)

When True (High) drive will ramp HAS unit to a stopped condition in extend motion only. Ramp time value is set by keypad entry Page 26 for details. It is recommended to remove CMD input when this condition is seen.

Retract LS (Input)

When True (High) drive will ramp HAS unit to a stopped condition in retract motion only. Ramp time value is set by keypad entry Page 23 for details. It is recommended to remove CMD input when this condition is seen.

Profiler (input)

When True (High) drive will spin at a 2nd predetermined speed setting. This function allows for fast approach and transitions to slow speed approach. Also useful for extend and retract speed matching. See page 27 for more details.

Reservoir Level (input)

Option Reservoir Low Oil level detection input, unit must be equipped with reservoir level switch function. Default setting when tripped (High) will issue a Low Oil Level Warning on Keypad. Through Keypad entry device can be set to "Trip" drive in Fault Condition See Page 39 for more details

Sourcing Outputs

CW Limit and CCW Limit

HAS Units equipped with Limit Switch or with Stop On PSI mode set. When condition is seen and motion stopped, discrete output is set for indication of condition.

For Stop on PSI see page 36 for details.

Faulted

If the drive trips under Fault condition, this output is set true.

⚠ PROP 65 WARNING **WARNING:** This product can expose you to chemicals including **Lead and Lead Compounds** which are known to the State of California to cause cancer and birth defects or other reproductive harm. For more information go to www.P65Warnings.ca.gov

Mode- Entry

Field is not Password Protected

Default Setting: Mode 0

Configure 0 for Basic Directional Control

Configure 1 for Speed and Direction (0-10V)

Configure 2 for Speed and Direction (0-20 mA)

Configure 3 for Speed and Direction (4-20 mA)

Configure 4 for Proportional Mode (+/- 10V)

To select operation Mode from Home Screen

Press **M** to display OPERATOR Menu at Level 1

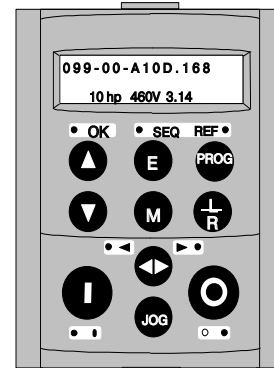

Home Screen

Press **▼** to scroll to HAS Mode Page

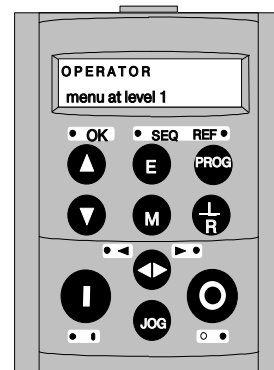

Operator Menu Screen

Press **M** to enable entry

-> will be displayed on left of entry indicating **▲** **▼** active for increasing/decreasing mode setting.

Press **▲** **▼** until proper value is set.

When correct, press **E**

Press **E** to return up one level

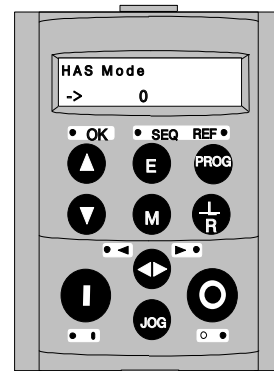

Operator Menu - Mode

▲ PROP 65 WARNING **WARNING:** This product can expose you to chemicals including **Lead and Lead Compounds** which are known to the State of California to cause cancer and birth defects or other reproductive harm. For more information go to www.P65Warnings.ca.gov

Basic Directional Control

Valve Mode 0

Traditional Hydraulic Valve Control equivalent

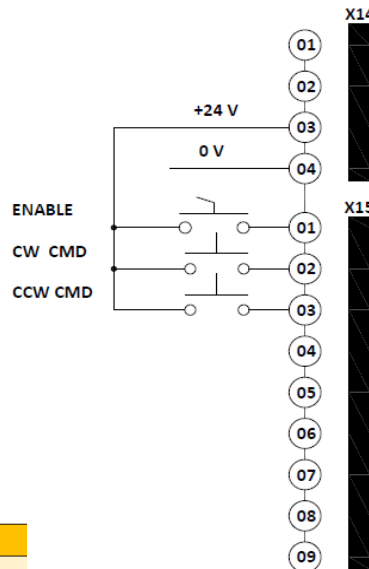
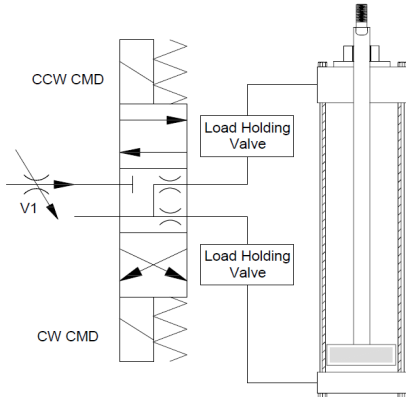

Digital Inputs Requirements	
Nominal Rated Voltage	24V DC
Absolute Maximum Input Voltage	-15V to +30 V
Input Threshold	9.0V +/- 2.5V
Sample Rate	1 mS
Input Current	7.3 mA @ 24V

Valve Mode - Keypad Entry Mode 0

Similar to cylinder operation with standard 4-way directional control valves, this simple operational mode allows direction control of the HAS actuator with simple push, pull discrete inputs.

Direction is set by inputs X15-02 and X15-03, with speed in either direction set by V1 in keypad menu.

V1 (Velocity setting 1) controls the pump speed at percentage rate of maximum rating of the size pump. This speed is closed loop at the motor, and cylinder speed may vary based upon pump leakage rates at different pressures. The control theory is similar

Enable (Input X15-01)

When True (High) drive will react to other discrete inputs. When False (Low) inputs are ignored. Useful for disabling unwanted pushbutton operation.

CW CMD (Input X15-02)

When True (High) drive will spin the pump in a clockwise function. HAS Speed is set by percentage of maximum setting V1 in keypad setup

The HAS orientation call out in the model code set the extend and retract direction. Orientations "A" & "H"(reservoir on Cap end) CW rotation Extend Cylinder, "B" & "C" (Reservoir on Head end) CCW rotation extends the cylinder.

CCW CMD (input)

When True (High) drive will spin the pump in a counterclockwise function. Same as CW command, cylinder will operate in opposite direction.

Soft-shift Control

When increasing speed setting from stop to V1 setting- acceleration or Ramp Rate (R1) is used to ramp from stop to V1 setting. When decreasing speed setting, deceleration or Ramp Rate (R2) is used to ramp from current speed to stopped condition. Default Ramp Rates are 300 mS. For Softer starts and Stops Ramp Rates can be increased through keypad entry.

⚠ PROP 65 WARNING **WARNING:** This product can expose you to chemicals including **Lead and Lead Compounds** which are known to the State of California to cause cancer and birth defects or other reproductive harm. For more information go to www.P65Warnings.ca.gov

Invert Direction - Entry

Default Setting:False

Configure FALSE for Orientations "A" & "H" (reservoir on Cap end) CW rotation Extend Cylinder

Configure True for Orientations "B" & "C" (Reservoir on Head end) CCW rotation extends the cylinder

Field is not Password Protected

To Invert Direction from Home Screen

Press **M** to display OPERATOR Menu at Level 1

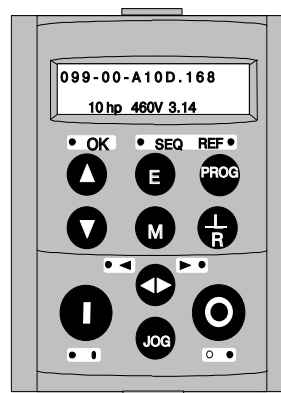

Home Screen

Press **▼** to scroll to Invert Direction Page

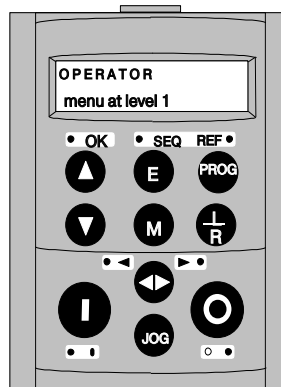

Operator Menu Screen

Press **M** to enable entry

-> will be displayed on left of entry indicating **▲ ▼** active for toggling Direction state setting.

Press **▲ ▼** until proper value is set.

When correct, press **E**

Press **E** to return up one level

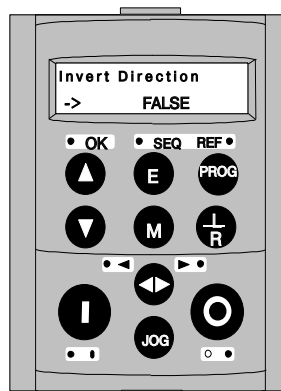

Operator Menu - Invert Direction

▲ PROP 65 WARNING WARNING: This product can expose you to chemicals including **Lead and Lead Compounds** which are known to the State of California to cause cancer and birth defects or other reproductive harm. For more information go to www.P65Warnings.ca.gov

Mode 0 Speed (V1) - Entry

Default Setting: 50%

Percentage value of maximum pump speed.

Field is not Password Protected

To SET V1 Speed from Home Screen

Press **M** to display OPERATOR Menu at Level 1

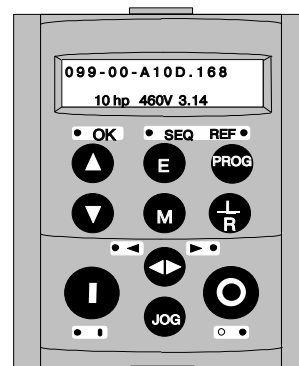

Home Screen

Press **▼** to scroll to HAS Speed (V1) Page



Operator Menu Screen

Press **M** to enable entry

-> will be displayed on left of entry indicating **▲** **▼** active for increasing/decreasing speed setting.

Press **▲** **▼** until proper value is set.

When correct, press **E**

Press **E** to return up one level

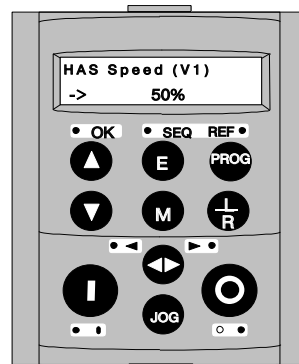

Operator Menu - Mode 1 Speed

▲ PROP 65 WARNING **WARNING:** This product can expose you to chemicals including **Lead and Lead Compounds** which are known to the State of California to cause cancer and birth defects or other reproductive harm. For more information go to www.P65Warnings.ca.gov

Acceleration (R1) - Entry

Default Setting: 0.3 sec

The time that the Drive will take to ramp the set-point from 0.00% to 100.00%

Field is not Password Protected

To SET R1 Speed from Home Screen

Press **M** to display OPERATOR Menu at Level 1

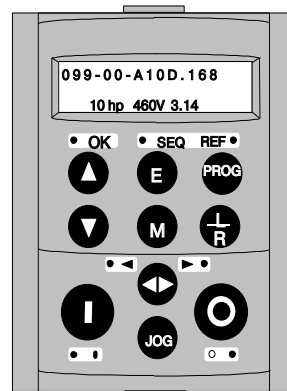

Home Screen

Press **▼** to scroll to HAS Accel (R1) Page

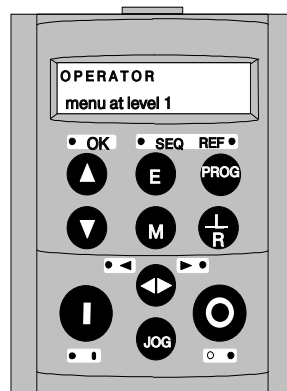

Operator Menu Screen

Press **M** to enable entry

-> will be displayed on left of entry indicating **▲** **▼** active for increasing/decreasing ramp setting.

Press **▲** **▼** until proper value is set.

When correct, press **E**

Press **E** to return up one level

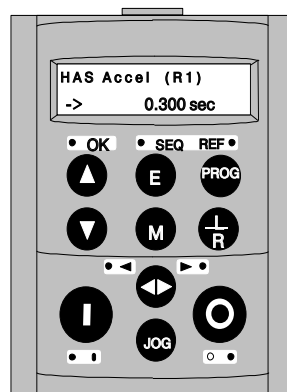

Operator Menu - Acceleration

▲ PROP 65 WARNING **WARNING:** This product can expose you to chemicals including **Lead and Lead Compounds** which are known to the State of California to cause cancer and birth defects or other reproductive harm. For more information go to www.P65Warnings.ca.gov

Deceleration (R2) - Entry

Default Setting: 0.3 sec

The time that the Drive will take to ramp the set-point from 100.00% to 0%

Field is not Password Protected

To SET R1 Speed from Home Screen

Press **M** to display OPERATOR Menu at Level 1

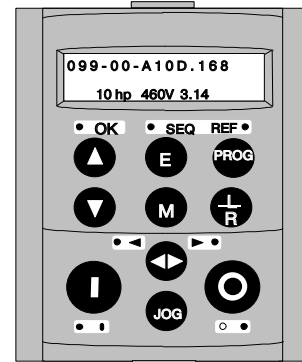

Home Screen

Press **▼** to scroll to HAS Decel (R2) Page

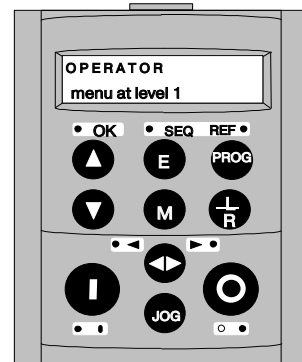

Operator Menu Screen

Press **M** to enable entry

-> will be displayed on left of entry indicating **▲** **▼** active for increasing/decreasing ramp setting.

Press **▲** **▼** until proper value is set.

When correct, press **E**

Press **E** to return up one level

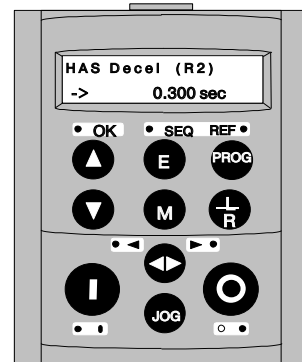

Operator Menu - Deceleration

▲ PROP 65 WARNING **WARNING:** This product can expose you to chemicals including **Lead and Lead Compounds** which are known to the State of California to cause cancer and birth defects or other reproductive harm. For more information go to www.P65Warnings.ca.gov

Basic Directional Control with End of Stroke Limit Switch

Traditional Hydraulic Valve Control Equivalent

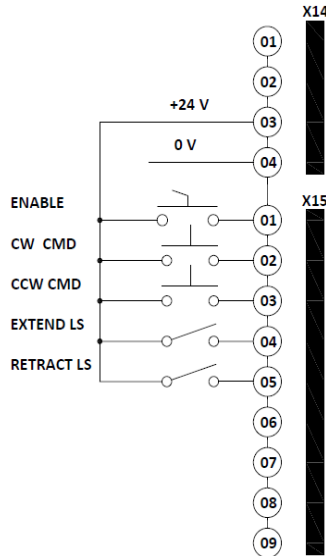
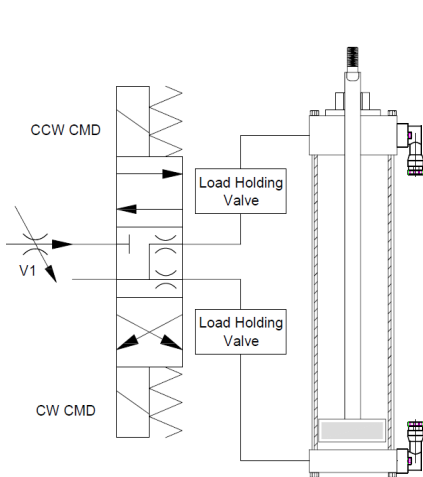

Valve Mode 0

Digital Inputs Requirements	
Nominal Rated Voltage	24V DC
Absolute Maximum Input Voltage	-15V to +30 V
Input Threshold	9.0V +/- 2.5V
Sample Rate	1 mS
Input Current	7.3 mA @ 24V

End of Stroke Limits

HAS Motion can be stopped by simply adding end of stroke limit switches either internal or external to the cylinder. Multiple internal switch options are available. See catalog HY08-1132-5NA for details.

Default switch setting is for Normally Open (NO) switch types, motion stopped on true signal. Switch setting can be changed to Normally Closed (NC) by keypad entry see page 40 for details.

The HAS orientation call out in the model code set the extend and retract direction. Orientations "A" & "H"(reservoir on Cap end) CW rotation Extend Cylinder, "B" & "C" (Reservoir on Head end) CCW rotation extends the cylinder. Orientation can be inverted through keypad entry see page 30 for details. **For proper operation of end of stroke limits, the proper Orientation must be configured.**

Extend Limit Switch (Input X15-04)

When input X15-04 is transition from its normal state, (either NO, or NC) forward motion command will be ignored, and motion will decelerate at the time value set in R2 (Decell) Valve can be changed by keypad entry see page 36 for details. When activated forward Commands will be ignored. HAS will be allowed to operate in Retract motion.

Retract Limit Switch (Input X15-05)

When input X15-05 is transition from its normal state, (either NO, or NC) retract motion command will be ignored, and motion will decelerate at the time value set in R2 (Decell) Valve can be changed by keypad entry see page 36 for details. When activated retract Commands will be ignored. HAS will be allowed to operate in Extend motion.

PROP 65 WARNING WARNING: This product can expose you to chemicals including **Lead and Lead Compounds** which are known to the State of California to cause cancer and birth defects or other reproductive harm. For more information go to www.P65Warnings.ca.gov

Limit Switch Type - Entry

Default Setting: False

Configure FALSE for Normally Open switch types, providing input to drive when active.

Configure True for Normally Closed switch types breaking input to drive when active

Field is not Password Protected

To SET Limit Switch Type from Home Screen

Press **M** to display OPERATOR Menu at Level 1

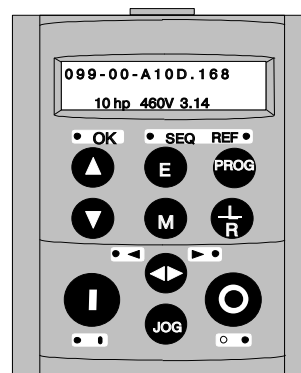

Home Screen

Press **▼** to scroll to L-Switch NC Page

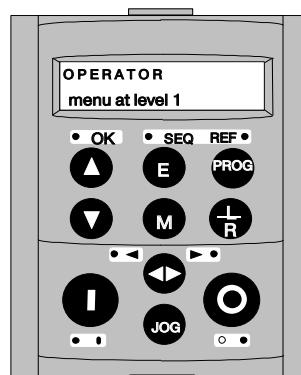

Operator Menu Screen

Press **M** to enable entry

-> will be displayed on left of entry indicating active for toggling Limit Switch state setting.

Press **▲** **▼** until proper value is set.

When correct, press **E**

Press **E** to return up one level

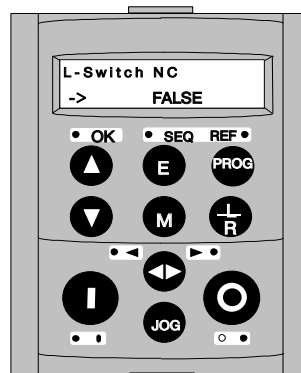

Operator Menu - Limit Switch State

▲ PROP 65 WARNING **WARNING:** This product can expose you to chemicals including **Lead and Lead Compounds** which are known to the State of California to cause cancer and birth defects or other reproductive harm. For more information go to www.P65Warnings.ca.gov

Two Speed Motion Profiler

Valve Mode 0

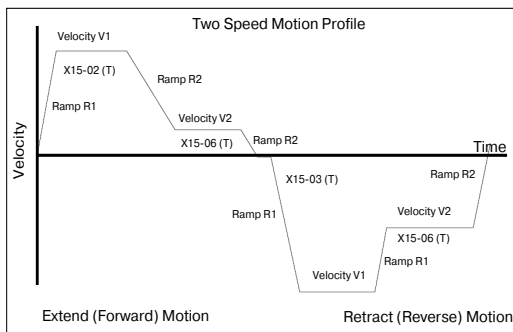
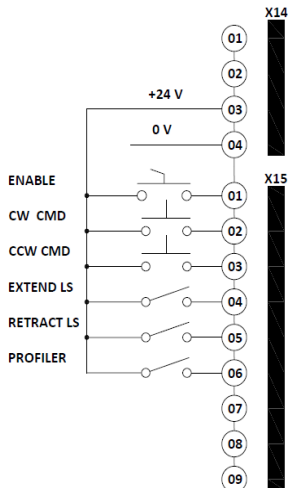
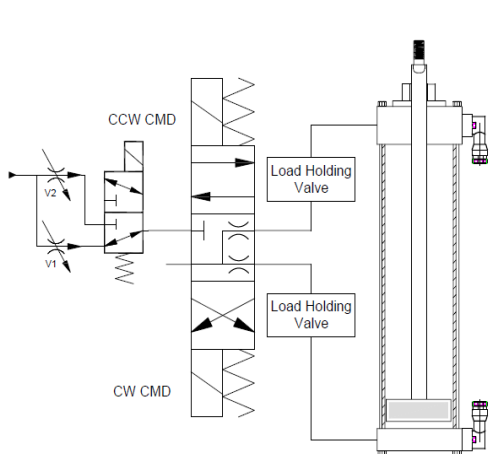

Motion Profiling

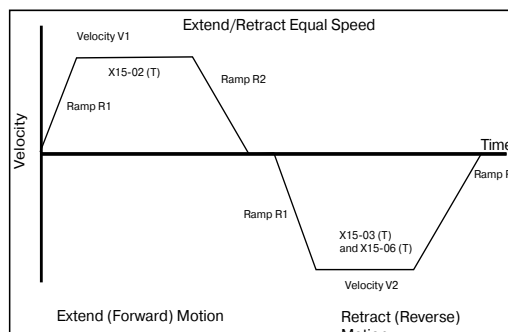

Equal Speed, Unequal Area Cylinders

Profiling (Input X15-06)

When input X15-06 is set High (True) a secondary Velocity setting (V2) is used to set the pump flow. The normal CW and CCW inputs dictate direction and must be used in conjunction with this setting.

When increasing speed setting- acceleration or Ramp Rate (R1) is used to ramp from current speed to new V2 setting. When decreasing speed setting, deceleration or Ramp Rate (R2) is used to ramp from current speed to new V2 setting. Velocity (V1, V2) and Ramp (R1, R2) settings are adjusted through keypad entry. See page 34-35 for more details.

This macro is useful when the desired motion is rapid advance, with a slow speed approach using only discrete inputs.

Equal Speed Option

When providing equal flow rates to unequal area cylinders, the cylinder will retract faster than extending due to the area difference. Using the Profiling input in conjunction with the retract input, this macro provides a secondary speed setting (V2) so that both Extend and Retract can be matched.

PROP 65 WARNING WARNING: This product can expose you to chemicals including **Lead and Lead Compounds** which are known to the State of California to cause cancer and birth defects or other reproductive harm. For more information go to www.P65Warnings.ca.gov



Mode 0 Speed (V2) - Entry Motion Profiler

Default Setting: 50%

Percentage value of maximum pump speed.

Field is not Password Protected

To SET V2 Speed from Home Screen

Press **M** to display OPERATOR Menu at Level 1

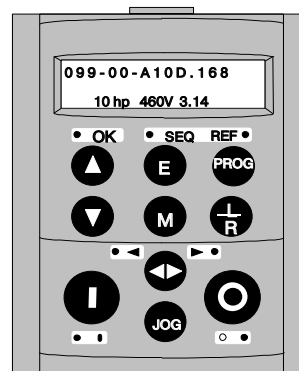

Home Screen

Press **▼** to scroll to HAS Speed (V2) Page



Operator Menu Screen

Press **M** to enable entry

-> will be displayed on left of entry indicating **▲** **▼** active for increasing/decreasing speed setting.

Press **▲** **▼** until proper value is set.

When correct, press **E**

Press **E** to return up one level

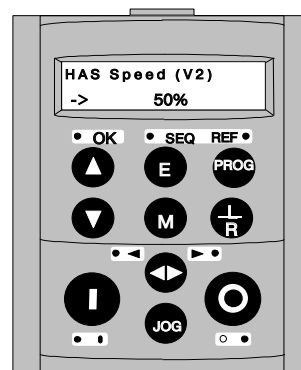

Operator Menu - Profiler Speed V2

▲ PROP 65 WARNING **WARNING:** This product can expose you to chemicals including **Lead and Lead Compounds** which are known to the State of California to cause cancer and birth defects or other reproductive harm. For more information go to www.P65Warnings.ca.gov

Speed and Direction 0-10V DC Input

Valve Mode 1

Traditional Hydraulic Valve Control Equivalent

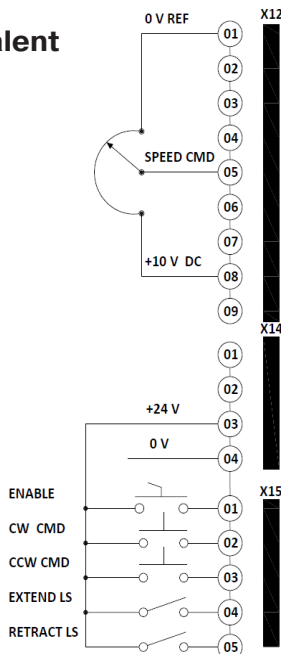
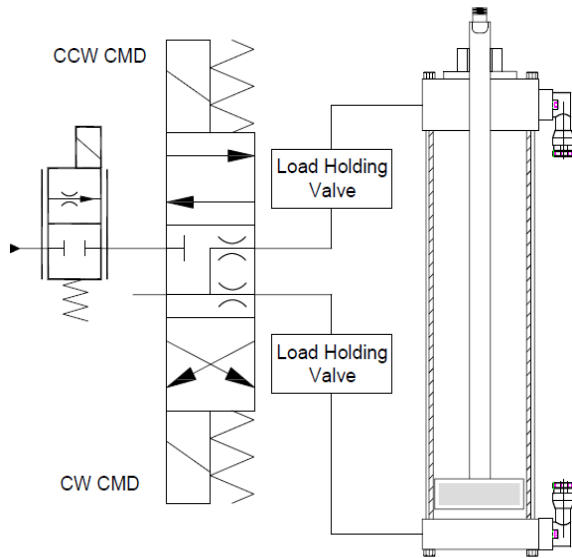

Analog Input Specifications	
Input Range	0-10V
Impedance	47K ohm
Resolution	12 bit
Sample Rate	100 mS

Valve Mode 1

Through Keypad Entry the user may change the default value "0" to "1" allows a infinite variable speed adjustment with a 0-10V DC analog Input. This setting will changeable on the fly. See page 19 for details on how to change mode.

Enable, Clockwise (CW), Counter-Clockwise (CCW), Extend and Retract Limits are fully functional in this operation mode.

When increasing speed setting- acceleration or Ramp Rate (R1) is used to ramp from current speed to new analog setting. When decreasing speed setting, deceleration or Ramp Rate (R2) is used to ramp from current speed to new analog setting. Ramp (R1, R2) settings are adjusted through keypad entry. See page 32-33 for more detail.

Note: The range of input is scaled to ensure minimum pump speed is maintained for proper operation. The speed range is set by the Pump displacement from the HAS Ordering Code. The Macro also includes a 1% of total command set as dead band to prevent unwanted travel due to electrical noise imposed on input.

Example 1: 3 cc pump (G03) ordering code, Max pump speed is 4000 RPM. Min pump speed 500 RPM. 10V input equals 100% of max speed, while 5V input equates to 56% of max speed. An input of 0.09V will be ignored and no motion generated.

Example 2: 11 cc pump (G11) ordering code, Max pump speed is 2400 RPM. Min pump speed 500 RPM. 10V input equals 100% of max speed, while 5V input equates to 60% of max speed. An input of 0.09V will be ignored and no motion generated.

This macro is useful when the desired motion needs to be changed infinitely from a master Programmable Logic Controller (PLC) or if speed Potentiometer is desired.

PROP 65 WARNING WARNING: This product can expose you to chemicals including **Lead and Lead Compounds** which are known to the State of California to cause cancer and birth defects or other reproductive harm. For more information go to www.P65Warnings.ca.gov

Speed and Direction 0-20 mA Input

Valve Mode 2

Traditional Hydraulic Valve Control Equivalent

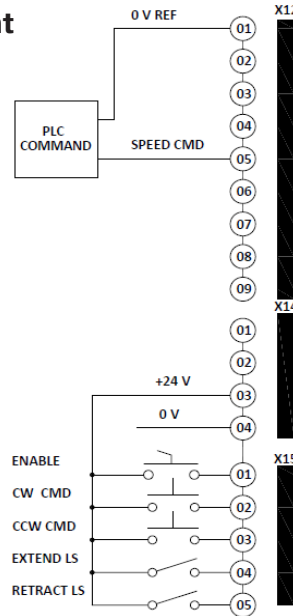
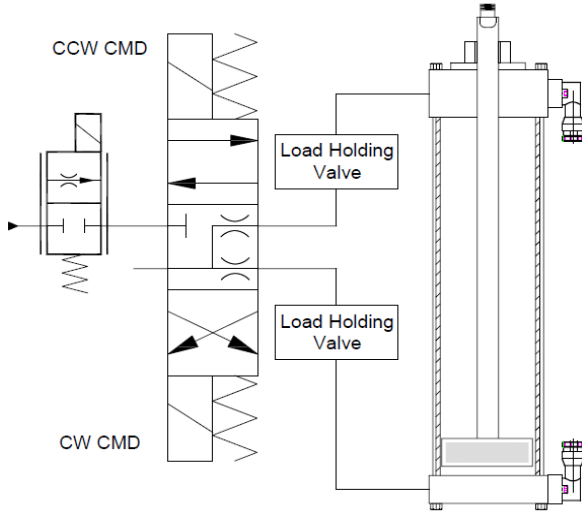

Analog Input Specifications	
Input Range	0-20 mA
Impedance	150 Ohm + series diode
Resolution	12 bit
Sample Rate	100 ms

Valve Mode 2

Through Keypad Entry the user may change the default value "0" to "2" allows a infinite variable speed adjustment with a 0-20 mA analog Input. This setting will changeable on the fly. See page 22 for details on how to change mode.

Enable, Clockwise (CW), Counter-Clockwise (CCW), Extend and Retract Limits are fully functional in this operation mode.

When increasing speed setting- acceleration or Ramp Rate (R1) is used to ramp from current speed to new analog setting. When decreasing speed setting, deceleration or Ramp Rate (R2) is used to ramp from current speed to new analog setting. Ramp (R1, R2) settings are adjusted through keypad entry. See page 34-35 for more detail

Note: The range of input is scaled to ensure minimum pump speed is maintained for proper operation. The speed range is set by the Pump displacement from the HAS Ordering Code. The Macro also includes a 1% of total command set as dead band to prevent unwanted travel due to electrical noise imposed on input.

Example 1: 3 cc pump (G03) ordering code, Max pump speed is 4000 RPM. Min pump speed 500 RPM. 20 mA input equals 100% of max speed, while 10 mA input equates to 56% of max speed. An input of 0.19 mA will be ignored and no motion generated.

Example 2: 11 cc pump (G11) ordering code, Max pump speed is 2400 RPM. Min pump speed 500 RPM. 20 mA input equals 100% of max speed, while 10 mA input equates to 60% of max speed. An input of 0.19 mA will be ignored and no motion generated.

This macro is useful when the desired motion needs to be changed infinitely from a master Programmable Logic Controller using a analog current type signal.

PROP 65 WARNING WARNING: This product can expose you to chemicals including **Lead and Lead Compounds** which are known to the State of California to cause cancer and birth defects or other reproductive harm. For more information go to www.P65Warnings.ca.gov



Speed and Direction 4-20 mA Input

Valve Mode 3

Traditional Hydraulic Valve Control Equivalent

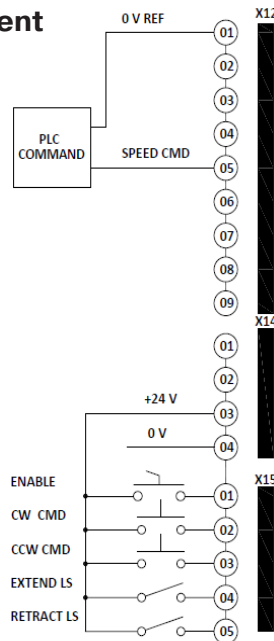
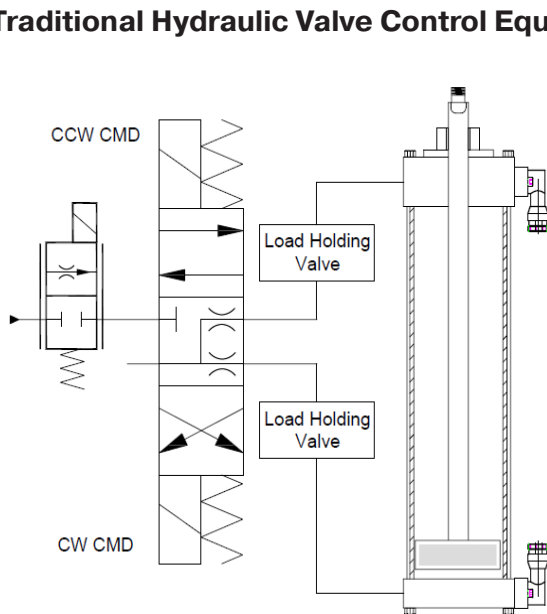

Analog Input Specifications	
Input Range	4-20 mA
Impedance	150 Ohm + series diode
Resolution	12 bit
Sample Rate	100 mS

Valve Mode 3

Through Keypad Entry the user may change the default value "0" to "3" allows a infinite variable speed adjustment with a 4-20 mA analog Input. This setting will changeable on the fly. See page 22 for details on how to change mode.

Enable, Clockwise (CW), Counter-Clockwise (CCW), Extend and Retract Limits are fully functional in this operation mode.

When increasing speed setting- acceleration or Ramp Rate (R1) is used to ramp from current speed to new analog setting. When decreasing speed setting, deceleration or Ramp Rate (R2) is used to ramp from current speed to new analog setting. Ramp (R1, R2) settings are adjusted through keypad entry. See page 34-35 for more detail

Note: The range of input is scaled to ensure minimum pump speed is maintained for proper operation. The speed range is set by the Pump displacement from the HAS Ordering Code. The Macro also includes a 1% of total command set as dead band to prevent unwanted travel due to electrical noise imposed on input.

Example 1: 3 cc pump (G03) ordering code, Max pump speed is 4000 RPM. Min pump speed 500 RPM. 20 mA input equals 100% of max speed, while 12 mA input equates to 56% of max speed. An input of 4.19 mA will be ignored and no motion generated.

Example 2: 11 cc pump (G11) ordering code, Max pump speed is 2400 RPM. Min pump speed 500 RPM. 20 mA input equals 100% of max speed, while 12 mA input equates to 60% of max speed. An input of 4.19 mA will be ignored and no motion generated.

This macro is useful when the desired motion needs to be changed infinitely from a master Programmable Logic Controller using a analog current type signal.

PROP 65 WARNING WARNING: This product can expose you to chemicals including **Lead and Lead Compounds** which are known to the State of California to cause cancer and birth defects or other reproductive harm. For more information go to www.P65Warnings.ca.gov



Proportional Mode

Valve Mode 4

Traditional Hydraulic Valve Control Equivalent

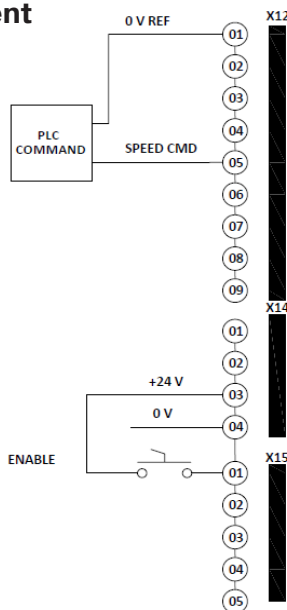
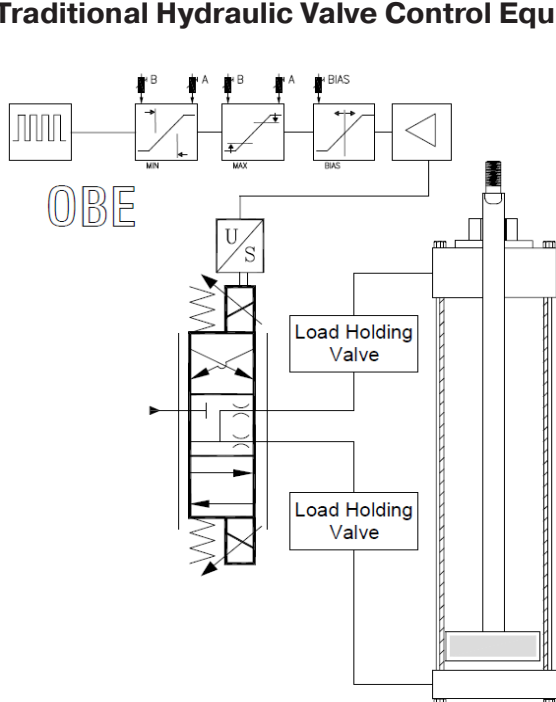

Analog Input Specifications	
Input Range	-10V to +10V
Impedance	47K ohm
Resolution	12 bit
Sample Rate	<1 mS

Valve Mode 4

Through Keypad Entry the user may change the default value "0" to "4" allows a infinite variable speed adjustment with a +10 to -10V DC analog Input. This setting can be changed on the fly and is useful when controlling a HAS unit with a Motion Controller. See page 22 for details on how to change mode.

The sign (polarity) of the signal dictates the direction and magnitude (value) controls the speed similar to the way a proportional valve control the flow with a bipolar input.

During this mode the drive will gear the pump speed to the scaled range. The drive will ramp in both directions, limited by the torque limiting value. If a step command is issued, and the acceleration torque is greater than the Torque limiting field set in the drive, the ramp rate will be dictated by the this torque rating.

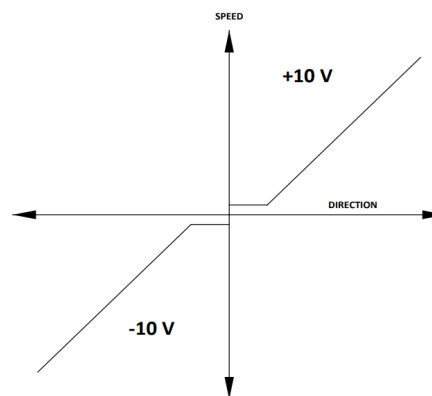

When controlling a HAS actuator with a closed loop motion controller, Mode 4 should be selected, and the default minimum pump speed and input deadband will be automatically changed to maintain linear control as we approach null. To minimize potential for hunting around null commands, the Drive Enable Control should be used in conjunction with the imposition tolerance of the control scheme. Note: It is possible to use a HAS unit in a closed loop manner, however since the control is not force-balance, and load holding valves are used, "servo" precise performance should not be expected.

Min pump speed and Signal dead band can be changed through the keypad, see full page 72 more details.

PROP 65 WARNING WARNING: This product can expose you to chemicals including **Lead and Lead Compounds** which are known to the State of California to cause cancer and birth defects or other reproductive harm. For more information go to www.P65Warnings.ca.gov

HAS Analog Connections

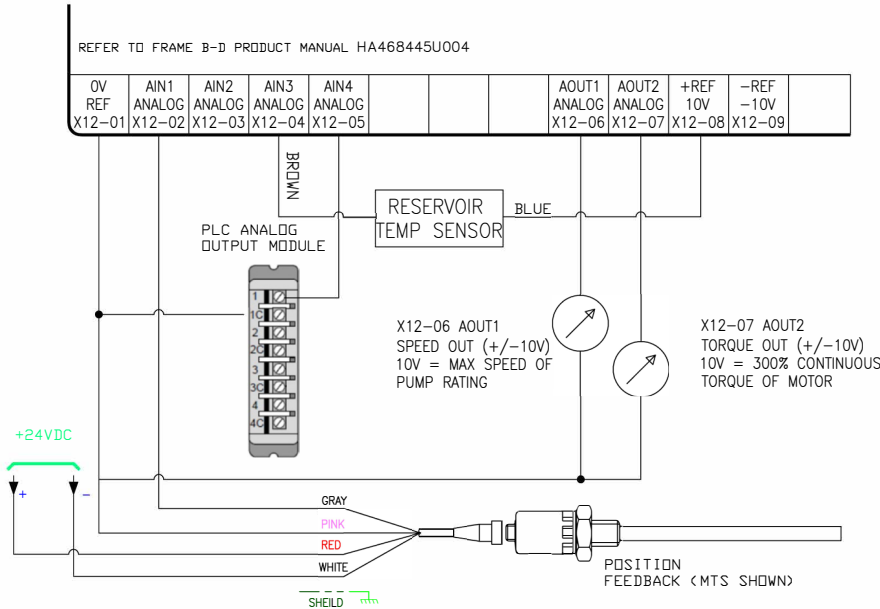

Analog Input Specifications	
Input Range	0-10V
Impedance	47K ohm
Resolution	12 bit
Sample Rate	100 mS
Analog Input Specifications	
Input Range	4-20 mA
Impedance	150 Ohm + series diode
Resolution	12 bit
Sample Rate	100 mS

Position Inputs

HAS Units ordered with Position Feedback device can be used to define an operational window, stopping HAS Motion when the analog input signal exceeds the value setting. This operation is similar to use of end of stroke switches, while providing flexibility in setting of operational window. 0-10V analog input is connected to connector X12, pin 2, reference to X12, pin 0.

Note: Cylinder feedback but be ordered with a 0-10V analog output to use this feature.

HAS Speed Input

With Operation Modes, 1, 2, 3 or 4, the macro accepts an analog input on connector X12, pin 5 for velocity control of the HAS actuator. This input auto-configures the analog input type, based upon mode selection via the keypad Mode entry.

Mode 4 (Proportional Mode) Update rate is 0.25 mS, and is intended for operation with an external motion controller, closing the loop around position.

Reservoir Temp

All HAS Drive kits are supplied with a Thermistor measuring reservoir Temp. It must be connected to the 10V supply at connector X12- Pins 4 and 8 for proper macro operation. This device will provide over temp warnings and used to control the heat exchanger operation if ordered.

Speed Output

HAS Analog Drive kits include a macro to provide an analog output (+/- 10V) proportional to running pump speed. The output is a bi-polar output with (+) sign linked to Clockwise Pump rotation, (-) CCW rotation. A 10V signal is scaled to maximum pump speed. Measurements at connector X12, Pin 6.

Torque Output

HAS Analog Drive kits include a macro to provide an analog output (+/- 10V) proportional to 3 times the rated torque of the motor supplied with the HAS unit. The output is a bi-polar output with (+) sign linked to Clockwise Pump rotation, (-) CCW rotation. A 10V signal is scaled to 3 times the rated torque valve of the motor. Measurements at connector X12, Pin 7.

PROP 65 WARNING WARNING: This product can expose you to chemicals including **Lead and Lead Compounds** which are known to the State of California to cause cancer and birth defects or other reproductive harm. For more information go to www.P65Warnings.ca.gov

Basic Directional Control with Stop on Position

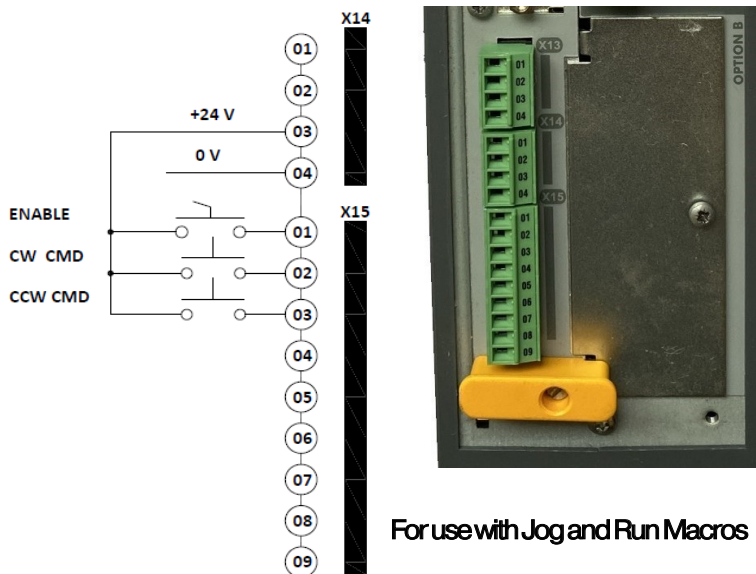

Stop on Position Value

Expandable feature for use with Run and Jog mode is the Stop on Position macro built into the drive. It requires a Position Feedback device should be ordered with the HAS unit. An external device may also be used.

Stop on Position is enabled through keypad commands and is available with both Jog and Run modes.

Macro Description:

Macro is enabled from the Stop On Position bit set on the keypad.

With proper setup, electronically adjustable window of stroke can be defined. User can define units, typically inch units are used, with a maximum value of 600.00". Resolution of High and Low limit is 0.00 units.

When HAS Unit measured positional value is greater than the High Limit value, the HAS Unit will decelerate and prevent forward motion.

When HAS Unit measured positional value is less than than the Low Limit value, the HAS Unit will decelerate and prevent reverse motion.

Position Feedback type is limited to 0-10V analog style units.

Position Feedback can be continuously monitored from the Position output register located on the Keypad.

⚠ PROP 65 WARNING **WARNING:** This product can expose you to chemicals including **Lead and Lead Compounds** which are known to the State of California to cause cancer and birth defects or other reproductive harm. For more information go to www.P65Warnings.ca.gov

Stop on Position Marco

Functional on
Mode 0
Mode 1-3

To select operation Mode from Home Screen

Press **M** to display OPERATOR Menu at Level 1

Press **▼** to scroll to Stop on Position

Press **M** to enable entry

-> will be displayed on left of entry indicating **▲▼** active for toggle True. When Correct press **E**

This feature now enable HAS operation only when HAS position is between operator defined window. When outside window Output H and C LS will be active.

Press **▼** to scroll to Position at 100%

Press **M** to enable entry

-> will be displayed on left of entry indicating active **▲▼** increasing/decreasing entry. Enter Position values measured at 10.0 V When Correct press **E**

This entry will define the units used to establish window of operation and display of HAS position on Keypad.

Press **▼** to scroll to Position STP

Press **M** High to enable entry

Entry establishes Extend Limit of stopping motion.

Repeat For Pos STP Low

Entry establishes Retract Limit of stopping motion.

These entry will define the point the HAS unit will start deceleration to zero speed. .

Fields are not Password Protected

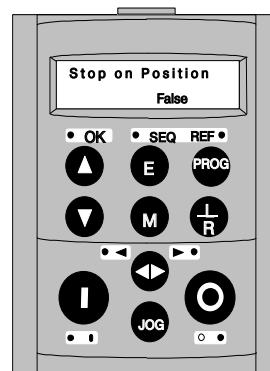

Stop On Position

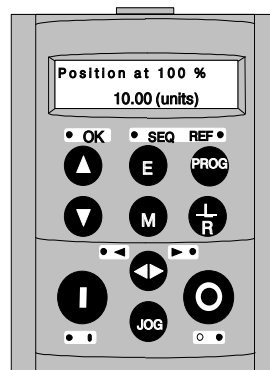

Position at 100%

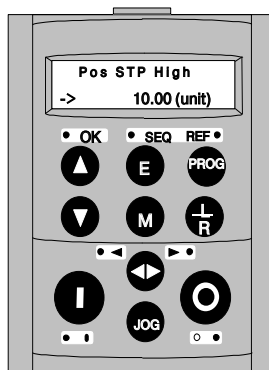

Extend Limit

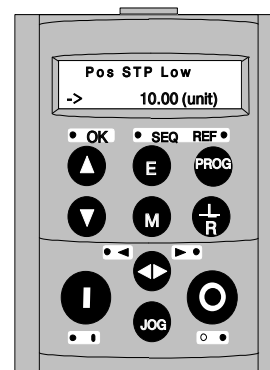

Retract Limit

▲ PROP 65 WARNING **WARNING:** This product can expose you to chemicals including **Lead and Lead Compounds** which are known to the State of California to cause cancer and birth defects or other reproductive harm. For more information go to www.P65Warnings.ca.gov

Basic Direction Control with Stop on PSI

Traditional Hydraulic Valve Control equivalent

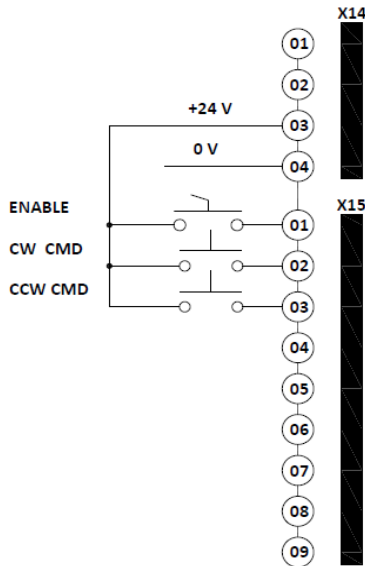
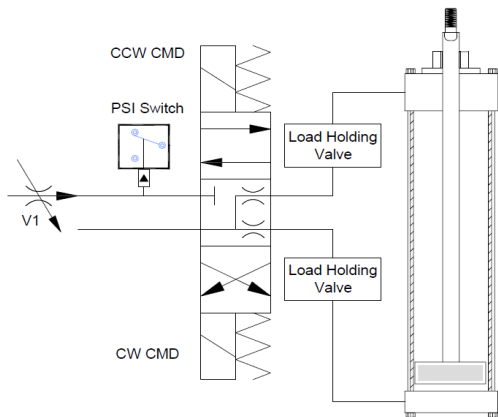

Valve Mode 0

Valve Mode - Keypad Entry Mode 0

Expandable feature for use with Valve Mode "0" is the Stop on PSI macro built into the drive.

Stop on PSI is enabled through Keypad entry and available for use with Mode 0, 1 2 and 3.

Macro Description:

With proper pump displacement entry, pressure can be approximated without the need of a pressure transducer. Theoretical pump pressure is calculated based upon the motor torque constant, and amp draw of the motor.

Additional User keypad entry required to determine the direction, pressure setting and duration required above setting to activate a stopping motion. See Page 40 for details

If precise pressure is required, please use pressure transducer option on the HAS model code, with an external device controller.

Stop on Position Marco

To select operation Mode from Home Screen

Press **M** to display OPERATOR Menu at Level 1

Press **▼** to scroll to Stop on PSI

Press **M** to enable entry

-> will be displayed on left of entry indicating **▲ ▼** active for toggle True. When Correct press **E**

This feature now Disable HAS operation when HAS Pressure exceeds value for duration longer than time setting. When true, unit is latched, output H and C LS will be active. To reset Latching, opposite direction must be commanded.

Press **▼** to scroll to CW STP PSI

Press **M** to enable entry

-> will be displayed on left of entry indicating active **▲ ▼** increasing/decreasing entry. Enter desired PSI Value to stop motion. When Correct press **E**

Repeat for CCW STP PSI ~ For stopping on Counter Clockwise rotation

Press **▼** to scroll to CW STP Time

Press **M** to enable entry

-> will be displayed on left of entry indicating active **▲ ▼** increasing/decreasing entry. Enter desired time duration above STP PSI setting before motion is stopped.

When Correct press **E**

Repeat for CCW STP Time~ Duration for stopping on Counter Clockwise rotation

Functional on Mode 0 Mode 1-3

Fields are not Password Protected



Stop On PSI

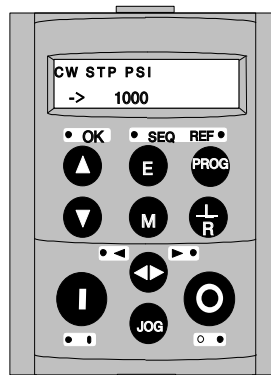

Stop On PSI Entry

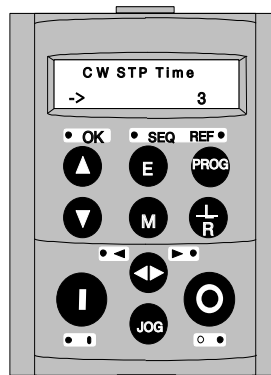

Stop On PSI Entry

▲ PROP 65 WARNING **WARNING:** This product can expose you to chemicals including **Lead and Lead Compounds** which are known to the State of California to cause cancer and birth defects or other reproductive harm. For more information go to www.P65Warnings.ca.gov

Heat Exchanger Options

Analog / Discrete Drive Version

To select operation Mode from Home Screen

Press **M** to display OPERATOR Menu at Level 1

Press **▼** to scroll to Cooler Control

Press **M** to enable entry

-> will be displayed on left of entry indicating active for toggle True. When Correct press



Keypad Entry

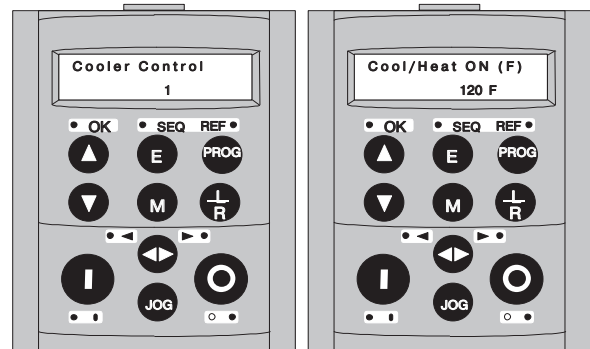

- 0 = Off
- 1 = On Clockwise Rotation
- 2 = On CCW Rotation
- 3 = On Both Rotation
- Direction 4 = Always On

Temp Setting to Start Cooling

Ten (10) degree delta to stop Cooling control.

This feature when true will close contacts X6-03 and X6-04 for controlling cooling loops. It can be used in conjunction with a relay to control the fan on the air cooled units, or water valve on water cooled units. The reservoir temperature sensor must be connected and wired for operation.

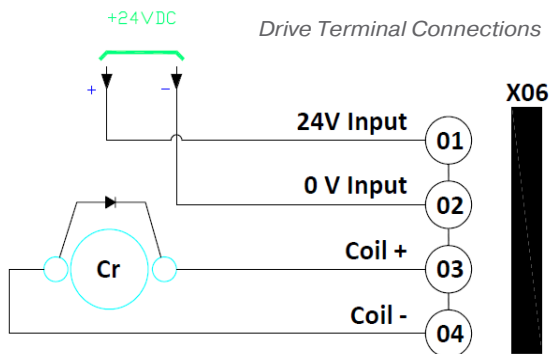

Air Cooled Option

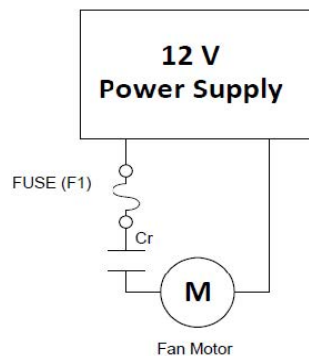

Water Cooled Option

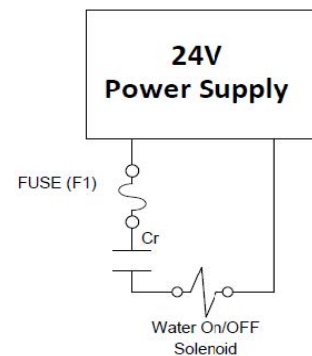

Has Filter/Cooler Codes: J thru R

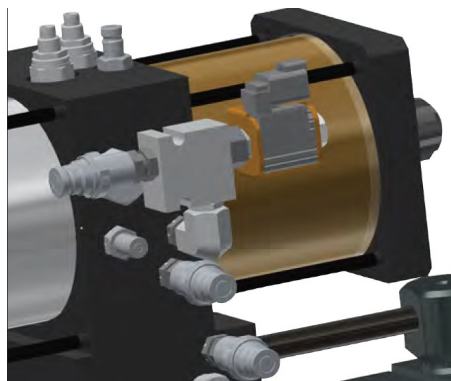

Has Filter/Cooler Codes: J thru R include a Solenoid valve on HAS Upper manifold. With higher bleed flows it maybe desirable to control when to bleed, this is achieved with additional solenoid valve.

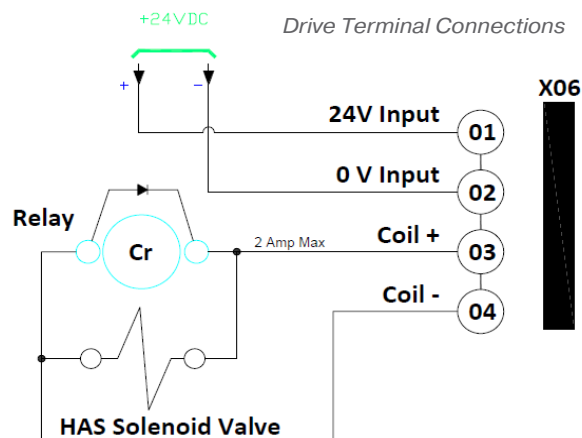

PROP 65 WARNING WARNING: This product can expose you to chemicals including **Lead and Lead Compounds** which are known to the State of California to cause cancer and birth defects or other reproductive harm. For more information go to www.P65Warnings.ca.gov

HAS Reservoir Temp Sensor Installation

Reservoir Temperature: HAS500 manifolds are equipped with mounting provisions to accept a thermistor. HAS 500 Series drive kits include the thermistor, 5 meter cable and macro in the drive to warn of High Oil Temp with the option to enable shut down HAS operation on over temperature conditions.



Temp Sensor Part No:
 0992480000 Mating Cable:
 086620T005
 IP Rating: IP67
 Connector: M8 Nano 3 pin

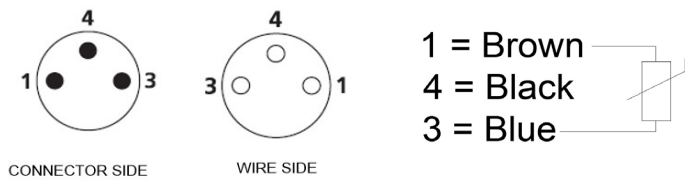

HAS Reservoir Temperature Sensor (Thermistor) Mounting

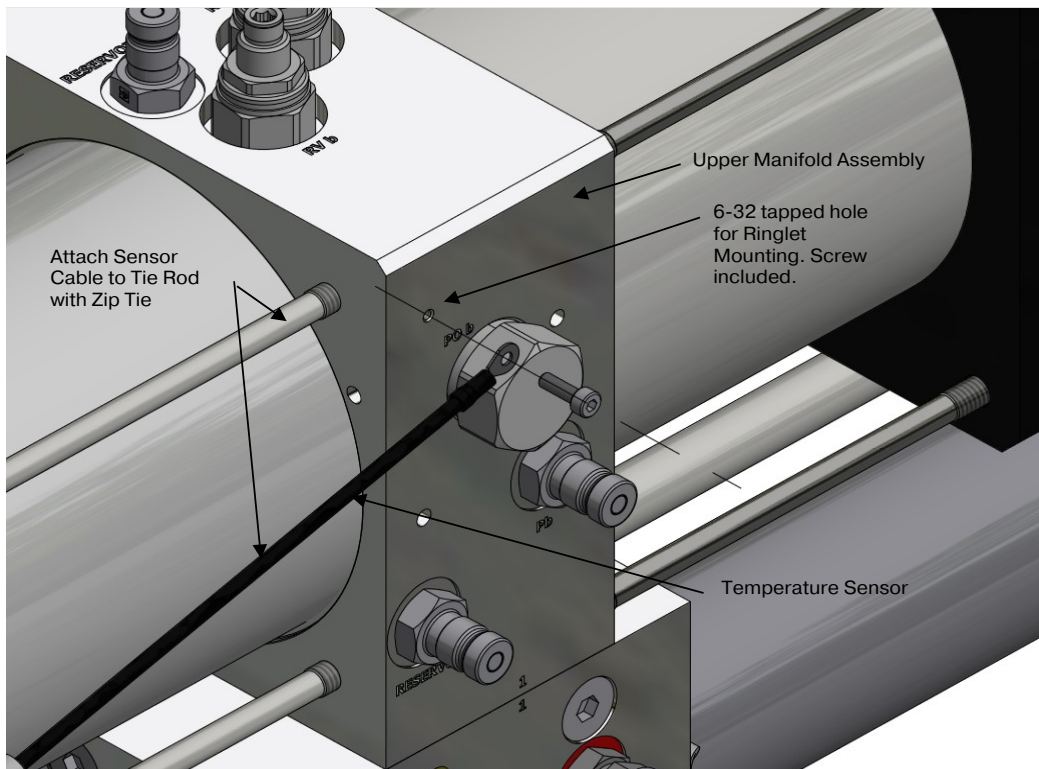

PROP 65 WARNING **WARNING:** This product can expose you to chemicals including **Lead and Lead Compounds** which are known to the State of California to cause cancer and birth defects or other reproductive harm. For more information go to www.P65Warnings.ca.gov

General Information

This section provides general information about STO.

Two safety functions can be implemented with the 890: Safe Torque Off (STO) and Safe Stop 1 (SS1). In order to meet all aspects of STO and SS1, an external safety control unit should be used.

To implement Safe Stop 1 (SS1), the external safety control unit causes the drive to decelerate to rest. Once at rest, it invokes STO in the 890. Please refer to EN61800-5-2:2007 para 4.2.2.3 for the formal definitions.

It is the user's responsibility to:

- 1) Risk assess the machine.
- 2) Design, implement and assess an appropriate solution for each application to meet all relevant safety requirements.

Note: STO is an electronic inhibit intended for use during normal operation of the machine. It is not intended for use during machine maintenance, repair, replacement or other similar activities. For these activities recognized electrical power isolation devices and lock-off procedures should be used.

The 890 STO function is a factory-fitted and factory-tested feature. It is only compatible with firmware versions 3.5 and onwards. See the section "**Safety Warnings and Limitations**" on page 6-21.

STO Functional Description

STO is a means of preventing an 890 drive from delivering power to its connected electric motor. Please refer to EN61800-5-2:2007 para 4.2.2.2 for the formal definition.

To ensure a high degree of safety, two independent STO control channels are implemented in hardware. The STO circuit in the 890 is designed such that a fault in one control channel will not affect the other channel's ability to prevent the drive from starting, i.e. the STO function of the 890 drive is tolerant to any single fault. It may not be tolerant to an accumulation of faults. This is in keeping with its declared safety ratings.

STO always overrides any attempt to start the drive. If one or both STO control inputs is requesting the STO function, the drive will not start, even if for example, the drive's software malfunctions and tries to cause the motor to turn.

The STO function is implemented in hardware; it overrides all software activities. The only software involvement is to report STO status to the user via an MMI, serial communications link or user terminal on the 890 control board as defined by the drive configuration.

WARNING

THE DECLARED SIL/PL CAPABILITY OF THIS STO PRODUCT CAN BE ACHIEVED ONLY WHEN THE TWO STO USER INPUTS ARE DRIVEN INDEPENDENTLY. THEY MUST NOT BOTH BE DRIVEN FROM A COMMON SOURCE; OTHERWISE THE SINGLE FAULT DETECTION WILL BE COMPLETELY INOPERATIVE.

USE OF THE PRODUCT IN THIS "COMMON SOURCE" CONDITION INVALIDATES THE STO PRODUCT SPECIFICATION AND IS ENTIRELY AT THE USER'S OWN RISK.

 **PROP 65 WARNING** **WARNING:** This product can expose you to chemicals including **Lead and Lead Compounds** which are known to the State of California to cause cancer and birth defects or other reproductive harm. For more information go to www.P65Warnings.ca.gov

Alignment to European Standards ENISO13849-1:2008

(Safety of machinery – Safety-related parts of control systems)

STO aligns internally to the following aspects of this standard:

- **Architecture according to Category 3:**

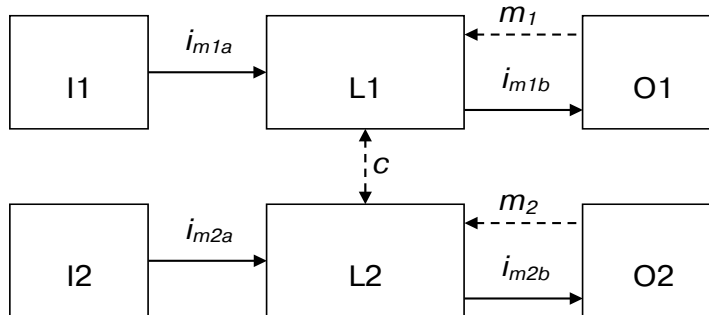

Solid lines represent the STO control paths.

Dashed lines represent reasonably practicable fault detection.

- Key:
- I1, I2 = user terminal
 - L1, L2 = logic
 - O1, O2 = methods of enabling or disabling output power devices
 - i_{mxy} = interconnecting means
 - m_x = monitoring
 - c = cross monitoring

- **Category 3 general requirements are:**

A single failure, and any consequential failures, will not lead to loss of the STO safety function.

Failure of more than one component can lead to the loss of the STO safety function.

Most but not all single component failures will be detected. Diagnostic Coverage (DC) is required to be at least 60% (i.e. the minimum required for 'low' diagnostic coverage).

Detected component failures will result in the STO function being applied without intervention from the user.

The risk associated with the loss of STO safety function caused by multiple failures must be understood and accepted by the user.

The user must undertake a risk analysis and specify suitable components that, when connected together, meet the required risk assessment requirements.

Mean Time To Failure (dangerous) (MTTFd) of each STO channel must be ≥ 30 years.

Common Cause Failure (CCF) score must be ≥ 65 according to Annex F of the standard.

- **Performance Level e:** Average Probability of dangerous Failure per Hour (PFH) must be $\leq 10^{-7}$

EN61800-5-2:2007 and EN61508

(Adjustable speed electrical power drive systems) and
 (Functional safety of electrical/electronic/programmable electronic safety-related systems)

STO aligns to the following aspects of this standard:

- Safety Integrity Level 3
 - Probability of dangerous random hardware failures per hour (PFH) must be $\leq 10^{-7}$
 - Subsystems type A according to EN61508-2:2001 para 7.4.3.1.2
 - Hardware Fault Tolerance (HFT) = 1
 - Safe Failure Fraction (SFF) must be $\geq 90\%$

Safety Specification

As assessed to EN ISO13849-1 and EN61800-5-2 and certified by BGIA (a German trade association for industrial safety) the 890 frames B to F have the following

Criterion	Requirement	Value achieved
SIL3	For type A subsystems, HFT = 1: SFF $\geq 60\%$	98%
SIL3	$10^{-7} \geq \text{PFH} \geq 10^{-8}$	1×10^{-9}
PLe	Category 3; $\text{PFH} \leq 4,29 \times 10^{-8}$	1×10^{-9}
PLe	$30 \text{ years} \leq \text{MTTFd} < 100 \text{ years}$	100 years ¹
PLe	DC = medium	Medium
Mission Time	20 years	20 years

Note: all values quoted in this table are valid only when the two STO user inputs are driven independently. This is as required by EN ISO 13849-1 category 3. See the Alignment to European Standards section in this chapter for the required architecture which must be used throughout the machine design relevant to the drive under consideration.

EMC Specification

In addition to the mandatory requirements of EN61800, the STO functionality has been subjected to testing for immunity at higher levels. In particular it has been tested for radiated immunity up to 3GHz which includes frequencies used by mobile telephones and walkie-talkies.

¹ EN ISO13849 limits MTTFd to 100 years.

User Connections

The STO terminals are on a 6-way terminal block X11. This is mounted on the front of the 890 control housing. Terminal designations are:

Terminal Number	Terminal Name	Description
X11/01	STO A Input	0V = drive will not run, STO is active on channel A. 24V = drive is enabled to run if X11/03 is also 24V. This input is optically isolated from all the other 890 terminals.
X11/02	STO Common2	Signal return for STO A and STO B inputs. Connected internally to X11/04. This terminal or X11/04 must be connected to earth at one common point in the drive system.
X11/03	STO B Input	0V = drive will not run, STO is active on channel B. 24V = drive is enabled to run if X11/01 is also 24V. This input is optically isolated from all the other 890 terminals.
X11/04	STO Common2	Signal return for STO A and STO B inputs. Connected internally to X11/02. This terminal or X11/02 must be connected to earth at one common point in the drive system.
X11/05	STO Status Negative	Together with X11/06, this terminal forms an isolated status output. Formed from semiconductor components it is therefore sensitive to voltage polarity. This output is on (equivalent to closed relay contacts) when the STO circuit is in the 'safe' state, i.e. the drive will not cause its motor to produce torque. However, this output should be used primarily as an indication. In the unlikely event of a fault in the STO circuit, this output could turn on erroneously to give a false indication of the STO status. It must not be used as a guarantee that the motor will not produce torque.
X11/06	STO Status Positive	Together with X11/05, this terminal forms a volt-free status output. See the description for X11/05.

² It is not recommended to connect 0V to both X11/02 and X11/04.

⚠ PROP 65 WARNING **WARNING:** This product can expose you to chemicals including **Lead and Lead Compounds** which are known to the State of California to cause cancer and birth defects or other reproductive harm. For more information go to www.P65Warnings.ca.gov

Examples of wiring to X11/05 and X11/06.

Active high output:

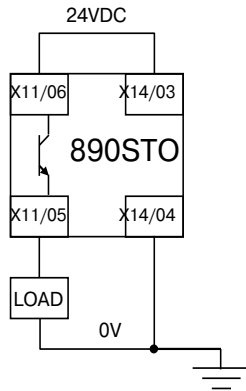

The load is energized and X11/05 is high when STO is in the intended safe STO state.

Active low output:

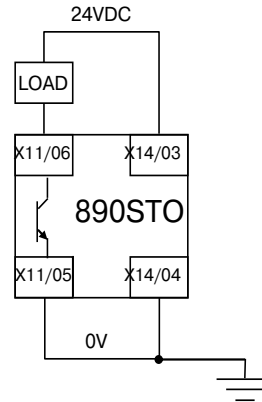

The load is energized and X11/06 is low when STO is in the intended safe STO state.

The examples show the use of the 24V supply provided on X14/03 (+24V) and X14/04 (0V) as source of power to a load. Alternatively an external 24V supply could be used.

Note: If a drive is powered from 24V only, i.e., 24V is applied to terminals X13/01 or X13/02 and the 3 phase power is off, the STO user output will still reflect the status of the two STO user inputs.

STO Technical Specification

Inputs Specification

STO A Input and STO B Input comply with IEC61131-2. Note: inputs do not have hysteresis.

Recommended input voltage for low level:	0V to +5V
Recommended input voltage for high level:	+21.6V to +26.4V
Typical input threshold voltage: Absolute	+10.5V
maximum input voltage: Typical input	-30V to +30V
current @ 24V Indeterminate input range:	9mA
Fault detection time ³ :	+5V to +15V. Function is undefined.
	2.3sec typical;
	< 1.6sec will not generate a fault
	> 3.0sec will generate a fault.

⚠ PROP 65 WARNING **WARNING:** This product can expose you to chemicals including **Lead and Lead Compounds** which are known to the State of California to cause cancer and birth defects or other reproductive harm. For more information go to www.P65Warnings.ca.gov

Output Specification

OFF state:

Maximum applied voltage: Reverse voltage protection:
 Leakage current:

+30V (X11/06 relative to X11/05)
 Up to -30V X11/06 relative to X11/05 Less than 1mA when output is off.

ON state:

Maximum output current:
 Overcurrent protection: Voltage drop X11/06 to X11/05:

150mA
 Included, implemented by a resettable fuse. Less than 2.5V, see below.

WARNING

WIRED CONNECTIONS TO TERMINALS X11/01, X11/03, X11/05 AND X11/06 MUST BE LESS THAN 25 METRES IN LENGTH AND REMAIN WITHIN THE CUBICLE OR DRIVE ENCLOSURE. PARKER HANNIFIN MANUFACTURING IS NOT LIABLE FOR ANY CONSEQUENCES IF EITHER CONDITION IS NOT MET.

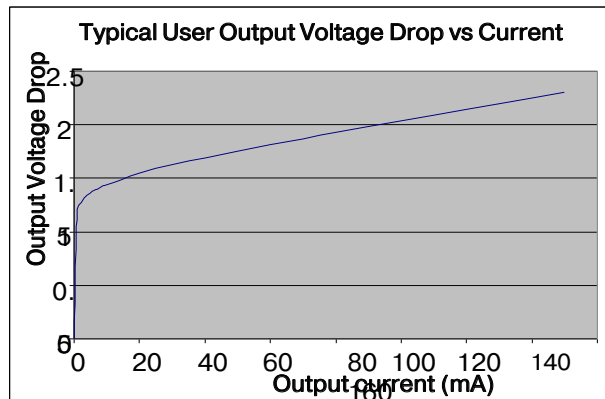

Truth Table

Overview	STO		Drive Function	STO Status
	Input A X11/01	Input B X11/03		Output X11/05, X11/06
STO Active	0V	0V	Drive cannot start or supply power to its motor. STO trip reported if drive is running or drive start is attempted. This is the intended safe state of the product with correct dual-channel operation.	ON
Abnormal one-channel operation detection	24V	0V	Drive cannot start or supply power to its motor. STO trip reported if drive is running or drive start is attempted. If either of these conditions persists for more than 3.0 seconds (the maximum fault detection time), the STO function will lock into a fault state. The drive cannot start until the fault is rectified, all power is removed and reapplied (both mains and any auxiliary 24V dc power). This is single channel operation and thus deemed not as intended for category 3 / PLe / SIL3 structure implementation.	OFF
	0V	24V		
STO Inactive	24V	24V	Drive is enabled to run under software control. The drive can supply power to its motor.	OFF

PROP 65 WARNING WARNING: This product can expose you to chemicals including **Lead and Lead Compounds** which are known to the State of California to cause cancer and birth defects or other reproductive harm. For more information go to www.P65Warnings.ca.gov



STO Input Timing Diagrams

Ideal Operation

In ideal operation, both inputs X11/01 and X11/03 should change state simultaneously reflecting true dual-channel operation as intended.

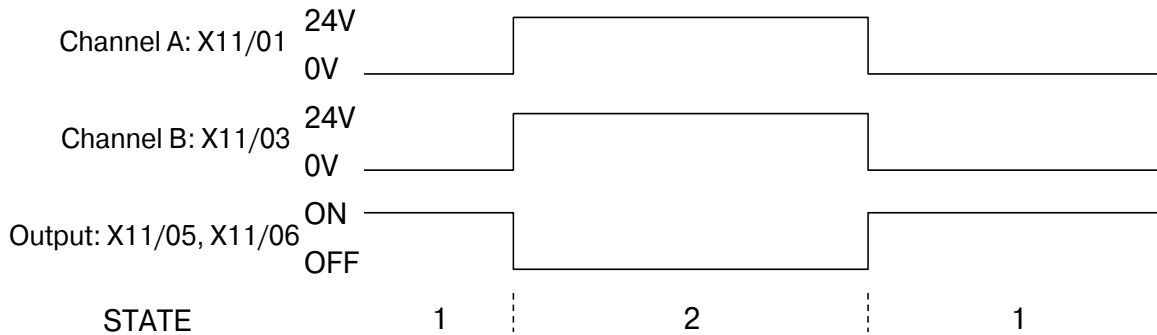

- 1 Both inputs are low. STO prevents the drive from starting. User output is ON. This is the “safe torque off” state of the drive.
- 2 Both inputs are high. Drive is able to run under software control. User output is OFF.

Normal Operation

In normal operation, there can be a small time difference between changes of state on X11/01 and X11/03, due to different delays in the operation of two sets of relay contacts.

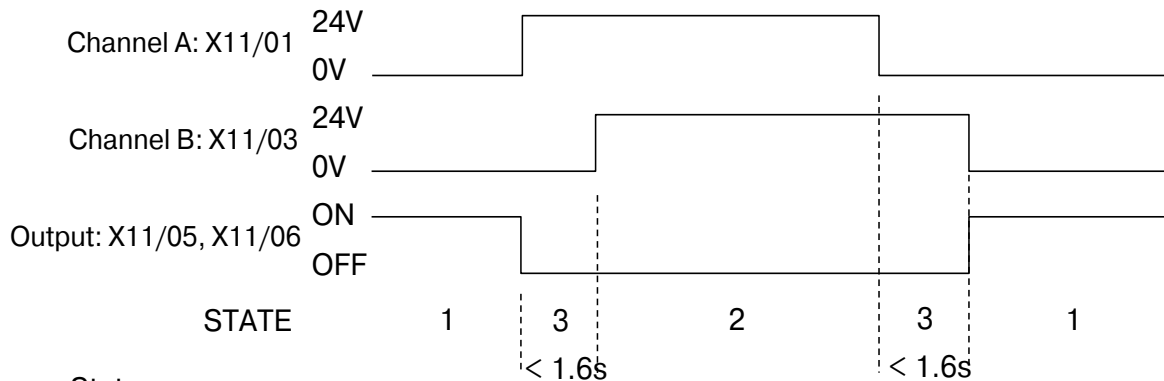

States:

- 1 Both inputs are low. STO prevents the drive from starting. User output is ON. This is the “safe torque off” state of the drive.
- 2 Both inputs are high. Drive is able to run under software control. User output is OFF.
- 3 One input is high and the other input is low. Drive cannot start due to STO action. User output is OFF. Normal operation allows this state to persist for up to 1.6 seconds which is the minimum fault detection time required to generate a fault (3.0 seconds is the maximum). These tolerable time differences are normally caused by switches or relays; they should be kept as short as possible.

Fault Operation

A fault is always detected when X11/01 and X11/03 are in opposite states for more than 3.0 seconds.

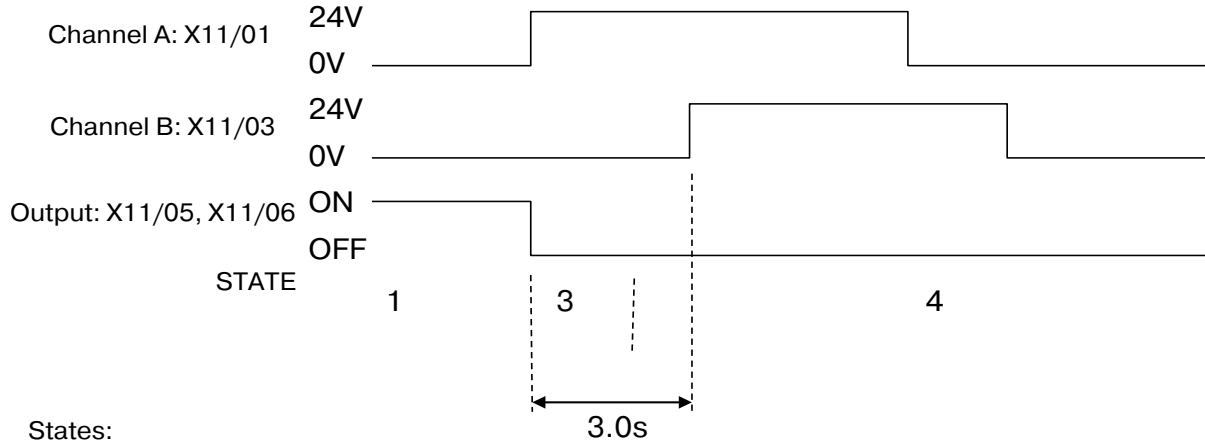

States:

- 1 Both inputs are low. STO prevents the drive from starting. User output is ON. This is the “safe torque off” state of the drive.
- 3 One input is high and the other input is low. STO prevents the drive from starting. In this example, this state persists for more than 3.0 seconds (being the maximum fault detection time), after which time the STO logic transitions to state 4 without further changes in input state. The 890 has detected single-channel operation.
- 4 The fault state (one input high, the other input low) has persisted for longer than 3.0 seconds (being the maximum fault detection time). The STO hardware logic locks into state 4. The STO function prevents the drive from starting. User output is OFF. To exit from state 4, the drive must be powered off (all power removed including any auxiliary 24Vdc) and back on

DANGER

OPERATION OF THE 890 UNIT SHOULD CEASE IMMEDIATELY AND THE UNIT SHOULD BE RETURNED TO PARKER HANNIFIN MANUFACTURING FOR INVESTIGATION AND REPAIR. FAILURE TO DO SO COULD RESULT IN INJURY, DEATH OR DAMAGE. FURTHER OPERATION OF THE 890 WITHOUT RESOLVING THIS FAILURE IS ENTIRELY AT THE USER’S OWN RISK. EE SAFETY CATEGORY DEFINITIONS AND LIMITATIONS, REFER TO EN ISO 13849-1:2008.

PROP 65 WARNING WARNING: This product can expose you to chemicals including **Lead and Lead Compounds** which are known to the State of California to cause cancer and birth defects or other reproductive harm. For more information go to www.P65Warnings.ca.gov



Pulse Inputs

Some safety equipment, e.g. safety PLCs, regularly pulse the two STO inputs independently in order to detect a short circuit between them. This is commonly known as OSSD (Output Signal Switch Device). The 890STO inputs are immune to such pulses when these are less than 2ms in width. The product will not react to such pulses and therefore will not inadvertently invoke the STO function.

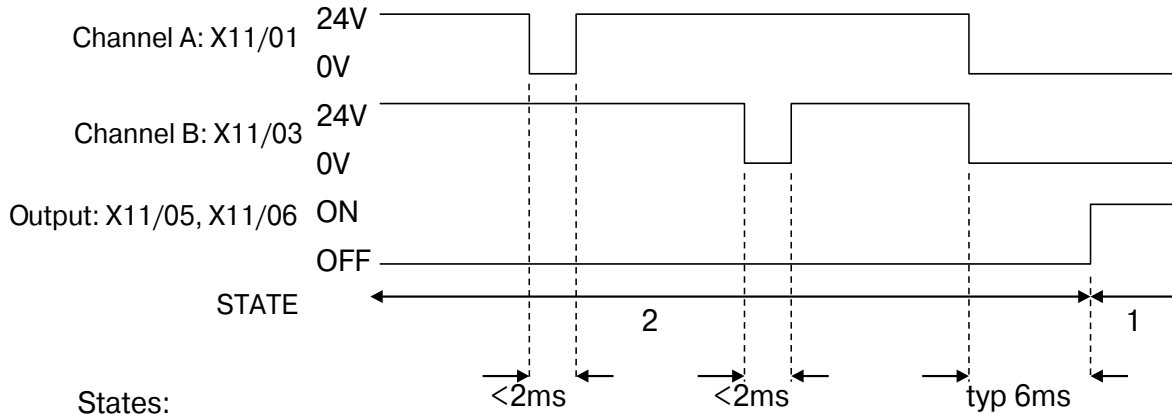

States:

- 1 Both inputs are low. STO prevents the drive from starting. User output is ON. This is the "safe torque off" state of the drive.
- 2 Both inputs are high, but regularly pulse low independently. External equipment can thus detect a short circuit between the two STO user inputs. Each input must remain low for 6ms (typical) before the 890 reacts to it.

STO State Transition Diagram

The flow chart below shows how the drive responds to STO inputs, start and stop commands.

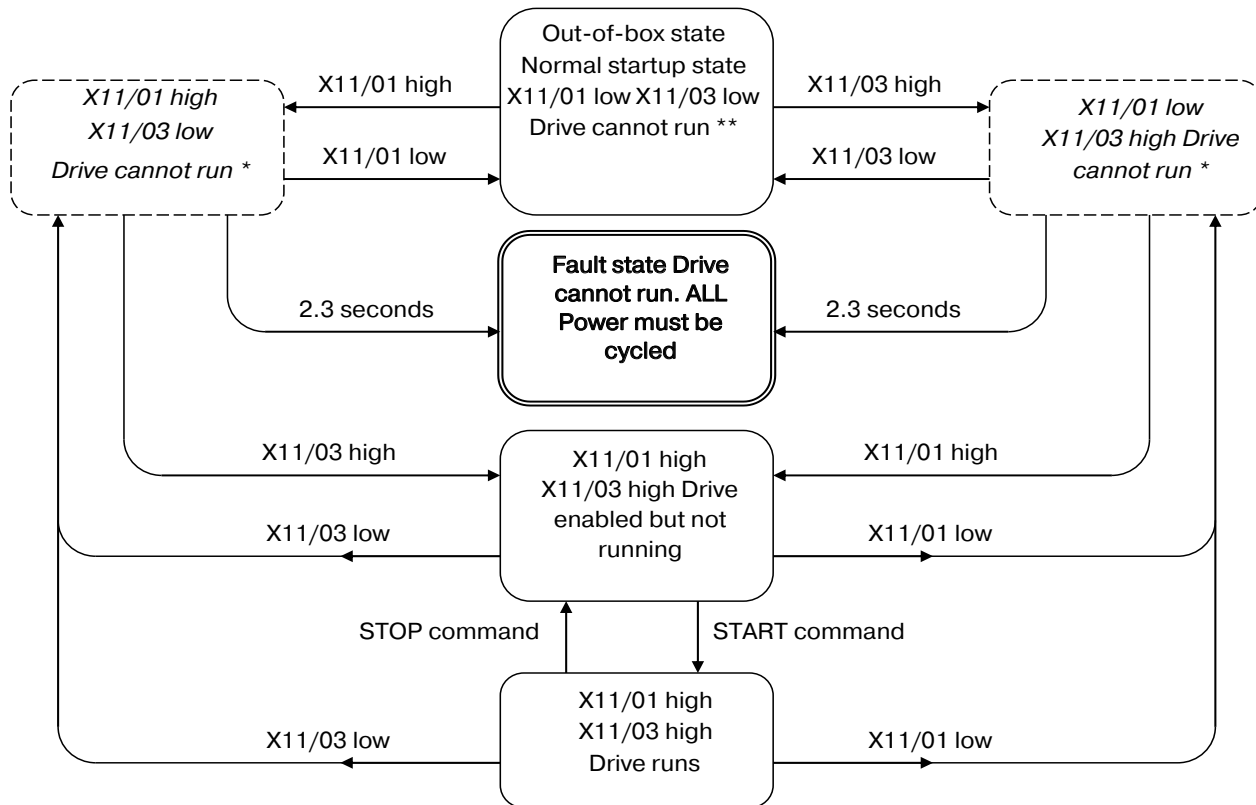

Key:

Normal state

Fault state

*Transitional state.
 User should avoid remaining in this state*

* = One channel operation

** = Two channel operation

PROP 65 WARNING WARNING: This product can expose you to chemicals including **Lead and Lead Compounds** which are known to the State of California to cause cancer and birth defects or other reproductive harm. For more information go to www.P65Warnings.ca.gov



STO Trip Annunciation

The MMI will display a STO trip message when STO becomes active, i.e. STO prevents the drive from running, thus:

*** TRIPPED *** SAFE
TORQUE OFF



6901 Operator Display

R5LO



6511 Operator Display

The above shows the two types of STO alarm text for when the (same) STO function has been activated. This message is displayed immediately if on starting the drive or whilst the drive is running:

- One or both STO user inputs X11/01 or X11/03 is low, or
- The 890 drive has detected a fault in the STO circuit.

Note that an out-of-box 890 drive will report this trip if the drive, as supplied, has no connections to X11 when it is first started. Appropriate connections must be made to X11 to prevent this trip from occurring, as described elsewhere in this chapter. The user must decide if STO is to be permanently inactive, or to make use of the STO feature. If you do not require to use the STO feature see the “Applications that do not require STO function” section on page ____

Safe Torque Off is inserted into the trips history buffer if STO is active when the drive is attempted to be started or if it becomes active while the drive is running, indicating an abnormal condition. The trips history buffer is not updated if STO becomes active while the drive is not running.

Note: The normal method of operation is for STO to become active while the drive is not running and the motor is intended not to rotate. Use on rotating motors or moving loads requires appropriate, application specific risk assessment.

Safety Warnings and Limitations

- Only appropriately qualified professional personnel are permitted to install the STO function and commission it. They must disseminate and make available all appropriate instructions and documentation to all personnel who may come into contact with or operate the STO and provide suitable training on the 890 to ensure it is operated in the correct manner and to avoid loss of life, injury or damage.
- The 890 STO function is a factory-fitted and factory-tested feature. It is only compatible with firmware versions 3.5 and higher. Repairs to 890 STO featured-products are to be carried out only by Parker. Any unauthorized attempt to use firmware before version 3.5, or to repair or disassemble the product will render any warranty null and void. Upgrading of non-STO product to STO product is strictly prohibited. PARKER HANNIFIN MANUFACTURING WILL NOT ACCEPT ANY LIABILITY FOR FAILING TO OBEY THESE INSTRUCTIONS OR FOR ANY CONSEQUENTIAL LOSS OR DAMAGE.
- It is important that the 890 product environment including all aspects of its CE conformance and IP etc., specified elsewhere in this manual, is maintained to ensure the safety integrity of the STO function.
- Should synchronous motors be operated in the field weakening range, operation of the STO function may lead to overspeed and destructive life-threatening overvoltages as well as explosions in the drive. Therefore, the STO function must NEVER be used with synchronous drives in the field-weakening range. The user must ensure this condition is prevented.
- When using synchronous permanent magnet motors, shaft movement over a small angle is possible if two faults occur simultaneously in the power section of the drive. This depends on the number of motor poles. The maximum angle is:
Rotary motors: $360^\circ / \text{number of poles}$
Linear motors: 180° electrically.
It is the user's responsibility to assess, validate and safeguard as necessary against this potential hazard.
- If external forces can act on the motor and/or load to cause it to move, additional measures must be taken by the user to restrain it, for example mechanical brakes. Examples of external forces are suspended loads (effect of gravity), and other web-tensioning devices.
- The 890 STO feature does not provide or guarantee any galvanic isolation in accordance with EN 60204-1 Section 5.5. This means that the entire system must be isolated from the mains power supply with a suitable electrical isolation device before any drive or motor maintenance or replacement procedures are attempted. Note that even after the power has been isolated, dangerous electrical voltages may still be present in the 890 drive. Safe discharge times and details are specified elsewhere in this manual.
- The STO function must not be used for electrical isolation of the 890 drive and power. Whenever any personnel require to work on the drive, associated motor or other power items, they must always use recognized and suitable electrical isolation devices and lock-off procedures as appropriate.
- Terminal X11/02 or X11/04 must be connected to earth at one common point in the drive system. For multi-drive systems this can be a shared earth point.
- The STO user output, serial communications or MMI messages relating to accessing or viewing any safety monitoring statuses are for information only and should not be relied on. They are not part of the drive module safety system and its associated PL/SIL declared rating. Any customer use of these must be appropriately risk assessed by the customer in accordance with any relevant standards or regulations.

 **PROP 65 WARNING** **WARNING:** This product can expose you to chemicals including **Lead and Lead Compounds** which are known to the State of California to cause cancer and birth defects or other reproductive harm. For more information go to www.P65Warnings.ca.gov

Safety Warnings and Limitations

- The STO safety function must be tested regularly. The frequency should be determined by the machinery builder. An initial frequency of once per week is suggested.
- When using an external safety control unit with adjustable time delay, for example when implementing an SS1 function, the time delay must be protected to prevent unauthorized adjustment. The adjustable time delay on the safety control unit must be set to a value greater than the duration of the braking ramp controlled by the 890 with maximum load inertia and from maximum speed. Any external forces must also be considered, e.g. effects due to gravity.
- When implementing a SS1 function with the 890, the user is responsible for ensuring the drive's configuration will allow a controlled braking ramp to be initiated by the external safety device. This is particularly important when using serial link communications for normal control of the drive.
- During the active braking phase of SS1 or Stop category 1 (controlled stop with safely monitored time delay according to EN60204-1), faulty operation of the drive must be allowed for. If a fault in the drive system occurs during the active braking phase, the load may coast to a stop or might even actively accelerate until expiration of the defined time delay. It is not the remit of this document to specify these measures. This is for the user to assess.
- When the 890 detects either an internal STO fault or an external single-channel user fault, the user must immediately fully resolve the fault. The user must ensure dual-channel operation has been fully restored before attempting to use the 890 STO safety feature.

DANGER

FAILURE TO DO SO COULD RESULT IN STO NOT BEING ACHIEVABLE, AND THUS THE MOTOR MAY ROTATE UNEXPECTEDLY AND COULD RESULT IN INJURY, DEATH OR DAMAGE. FURTHER OPERATION OF THE 890 WITHOUT RESOLVING THIS FAILURE IS ENTIRELY AT THE USER'S OWN RISK. SEE SAFETY CATEGORY DEFINITIONS AND LIMITATIONS, REFER TO EN SO 13849-1:2008.

- It is the user's responsibility to ensure that their overall control implementation recovers safely from supply loss or dips.
- In all instances it is the user's responsibility formally to perform suitable risk assessments, and invoke and fully validate the necessary risk reduction measures after having thoroughly understood the application, the drive product and its features.

 **PROP 65 WARNING** **WARNING:** This product can expose you to chemicals including **Lead and Lead Compounds** which are known to the State of California to cause cancer and birth defects or other reproductive harm. For more information go to www.P65Warnings.ca.gov

Example User Wiring

WARNING

THE WIRING EXAMPLES SHOWN IN THIS SECTION ARE FOR ILLUSTRATION ONLY. THEY ARE NOT TO BE CONSIDERED FINAL DESIGNS, NOR AS AN ATTEMPT TO CREATE A DESIGN FOR SPECIFIC SOLUTIONS. THE USER / INSTALLER IS RESPONSIBLE FOR DESIGNING A SUITABLE SYSTEM TO MEET ALL REQUIREMENTS OF THE APPLICATION INCLUDING ASSESSING AND VALIDATING IT.

PARKER HANNIFIN MANUFACTURING WILL NOT ACCEPT ANY LIABILITY FOR FAILURE TO DO THIS OR FOR ANY CONSEQUENTIAL LOSS OR DAMAGE.

Applications that do not require STO function

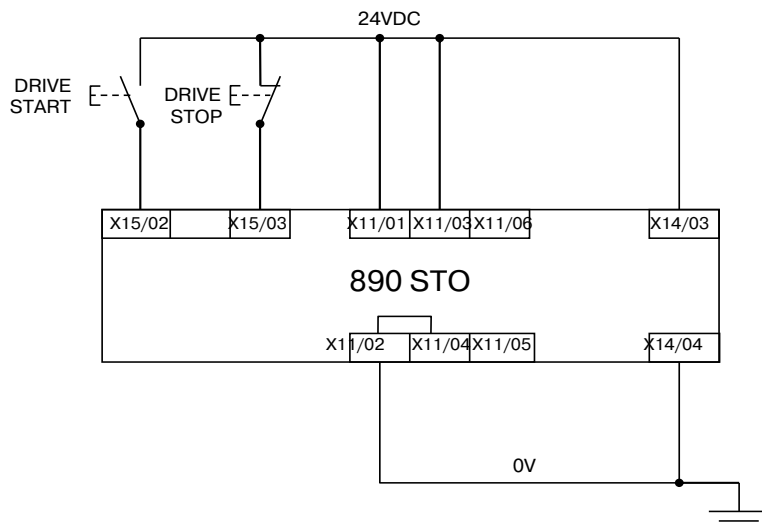

STO inputs X11/01 and X11/03 must be connected to 24VDC with respect to terminals X11/02 or X11/04.

STO Status output on X11/05 and X11/06 may be left disconnected.

All wiring shown is within the control cubicle.

Here the STO inputs X11/01 and X11/03 have been set to the inactive state (tied to +24V). Drive control is performed solely through software with no inherent safety function. The drive is controlled with its own start and stop pushbuttons.

Note: Only X11/02 or X11/4 must be earthed, i.e. they should not both be earthed otherwise it is possible to create an earth loop.

Minimum STO Implementation

This example shows the minimum connections required. To reset from STO requires that STO Request contacts are closed to permit normal drive operation. The user must do a risk assessment to ensure that all safety requirements are met. The user must select and assess appropriate equipment

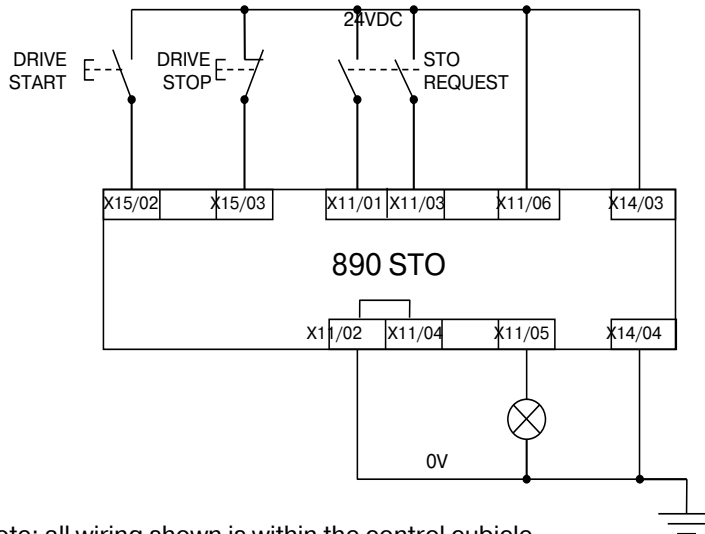

Note: all wiring shown is within the control cubicle.

To invoke STO:

- Press the DRIVE STOP button.
- Wait for the motor to come to rest.
- Open the STO Request contacts simultaneously. The contacts must remain open for the entire duration that STO is required, they must not be momentary action switches. The drive will confirm via X11/05 that STO has been invoked by the lamp being ON.
- If the lamp is OFF, do not access the machine as a fault may be present.
- Note: if the STO Request contacts open while the motor is rotating, the motor will coast to rest (unless external forces act on it).

To run the drive:

- Ensure the STO Request contacts are closed. Press the DRIVE START button.

To perform operational (not STO) stop:

- Press the DRIVE STOP button.
- Wait for the motor to come to rest.

See HA468445U004_09 for additional wiring suggestions for use with safety control circuits

STO Function Checking

Two levels of checking are required. A comprehensive check, and a regular check.

It is for the user / machine builder to determine the frequency of these checks based on their knowledge, use of the machine, appropriate standards and any legal requirements.

DANGER

ALL TESTS MUST PASS. IF ANY TEST FAILS, IT MUST BE INVESTIGATED AND RECTIFIED BEFORE ATTEMPTING TO PUT THE EQUIPMENT INTO SERVICE. FURTHER OPERATION OF THE 890 WITHOUT RESOLVING THIS FAILURE IS ENTIRELY AT THE USER'S OWN RISK. FAILURE TO DO SO COULD RESULT IN INJURY, DEATH OR DAMAGE. PARKER HANNIFIN MANUFACTURING WILL NOT ACCEPT ANY LIABILITY FOR FAILURE TO DO THIS OR FOR ANY CONSEQUENTIAL LOSS OR DAMAGE. SEE SAFETY CATEGORY DEFINITIONS AND LIMITATIONS, REFER TO EN ISO 13849-1:2008.

When STO becomes active during any test, power to the motor must be seen by the user to be quenched instantaneously. Note: the drive should respond in less than 10 milliseconds.

All STO checks should be performed after the 890 has been commissioned for speed control.

Comprehensive Check

A comprehensive check of the STO function ensures the overall integrity of the STO functionality. It proves the independent operation of each individual channel (including during the normal dual channel operation), the STO user feedback operation, and the essential single fault detection.

It must always be performed:

- During factory test
- During commissioning activities
- After repair or replacement of the 890
- After any hardware or software design changes which may affect the 890 concerned.
- After each intervention into the system and control wiring.
- At defined maintenance intervals as determined by the machine builder and /or user risk assessments and associated verification assessments.
- If the machine has been idle for more than a period of time determined by the machinery builder and user risk assessments.
- The check must be made by suitably qualified professional personnel following all necessary safety precautions. They must be fully conversant with all equipment concerned.

NOTE: In the following text where it is required that “all power” is removed, this can be validated by ensuring that the “STATUS” LED at the top of the control card and beneath terminal X10 goes and remains off (i.e., it is not flashing).

 **PROP 65 WARNING** **WARNING:** This product can expose you to chemicals including **Lead and Lead Compounds** which are known to the State of California to cause cancer and birth defects or other reproductive harm. For more information go to www.P65Warnings.ca.gov

WARNING

DURING THIS TEST, THE SAFETY FUNCTION MUST NOT BE RELIED ON BECAUSE AT TIMES ONLY ONE CHANNEL WILL BE ACTIVATED AND THEREFORE THE INTENDED SAFETY FUNCTION MAY NOT BE AVAILABLE. ALSO STO WILL BE ACTIVATED WHILE THE MOTOR IS ROTATING, WHICH IS NOT THE NORMAL OPERATION. THEREFORE THE USER MUST ENSURE IT IS SAFE TO DO THIS TEST BY USING AN APPROPRIATE RISK ASSESSMENT AND TAKING ANY ADDITIONAL RISK REDUCTION MEASURES.

The following test steps must be performed:

STO test	Comprehensive Check, Activity	Expected reaction and effect
1	Ensure that no harm can come to personnel or equipment if the motor turns.	
2	Apply +24V DC to terminals X11/01 and X11/03.	
3	Switch on power and 24V supply voltage.	No error must be present in the drive system. X11/05 and /06 must be OFF.
4	Configure the drive and associated equipment if necessary so that it can be started and stopped, and a speed setpoint provided.	No error must be present in the drive system. X11/05 and /06 must be OFF.
5	Try to start the drive with a non-zero setpoint. This setpoint value will be referred to as SPT1 for brevity in these tests. Leave this set throughout all tests.	Drive must start and motor must turn at SPT1. X11/05 and /06 must be OFF.

Channel A Check:

STO test	Comprehensive Check, Activity	Expected reaction and effect
6	With drive running and motor turning, momentarily disconnect terminal X11/01 (maximum duration of disconnect = 1 second), while retaining +24V at terminal X11/03.	Motor must immediately coast to rest. Drive must report STO trip immediately. X11/05 and /06 must remain OFF.
7	Ensure terminals X11/01 and X11/03 are both 24V. Try to restart the drive.	Drive must restart at SPT1. STO trip must clear. X11/05 and /06 must remain OFF.

Channel B Check:

STO test	Comprehensive Check, Activity	Expected reaction and effect
8	With drive running and motor turning, momentarily disconnect terminal X11/03 (maximum duration of disconnect = 1 second), while retaining +24V at terminal X11/01.	Motor must immediately coast to rest. Drive must report STO trip immediately. X11/05 and /06 must remain OFF.
9	Ensure terminals X11/01 and X11/03 are both 24V. Try to restart the drive.	Drive must restart at SPT1. STO trip must clear. X11/05 and /06 must remain OFF.

⚠ PROP 65 WARNING **WARNING:** This product can expose you to chemicals including **Lead and Lead Compounds** which are known to the State of California to cause cancer and birth defects or other reproductive harm. For more information go to www.P65Warnings.ca.gov



The following test steps must be performed:

Channel A Fault Check:

STO test	Comprehensive Check, Activity	Expected reaction and effect
10	Ensure the drive is running and the motor is turning. Disconnect terminal X11/01 for approximately 5 seconds (must exceed 3 seconds).	Motor must immediately coast to rest. Drive must report STO trip immediately. X11/05 and /06 must remain OFF.
11	The STO function has latched in hardware to disable the drive. Re-apply 24V to terminal X11/01, and then try to restart drive.	Drive must not start Drive must continue to report STO trip. X11/05 and /06 must remain
12	Remove and re-apply all power to the drive	X11/05 and /06 must be OFF.
13	Try to restart the drive.	Drive must start at SPT1. X11/05 and /06 must remain OFF.

Channel B Fault Check:

STO test	Comprehensive Check, Activity	Expected reaction and effect
14	Ensure the drive is running and the motor is turning. Disconnect terminal X11/03 for approximately 5 seconds (must exceed 3 seconds).	Motor must immediately coast to rest. Drive must report STO trip immediately. X11/05 and /06 must remain OFF.
15	The STO function has latched in hardware to disable the drive. Re-apply 24V to terminal X11/03, and then try to restart drive	Drive must not start. Drive must continue to report STO trip. X11/05 and /06 must remain OFF
16	Remove and re-apply all power to the drive	X11/05 and /06 must be OFF.
17	Try to restart the drive.	Drive must start at SPT1. X11/05 and /06 must remain OFF
18	Stop the drive.	Drive must decelerate to rest. X11/05 and /06 must remain OFF.

User Output Check:

STO test	Comprehensive Check, Activity	Expected reaction and effect
19	Remove connections to X11/01 and X11/03 within 1 second of each other.	X11/05 and /06 must be ON.
20	Try to restart the drive. Wait for at least 10 seconds with the run command active, then remove it.	Drive must not start while run command is given. Drive must report STO trip immediately. X11/05 and /06 must remain ON.
21	Reconnect X11/01 and X11/03 to 24V.	X11/05 and /06 must turn OFF immediately.
22	Try to restart the drive.	STO trip must clear. The drive must restart at SPT1.
23	Stop the drive. Test is complete.	Drive must stop.

The performance of the individual test steps of the STO function should be logged.

The tests specified above are the minimum set; further test steps may be required depending on the application, for example a controlled stop should be verified in a SS1 application.

⚠ PROP 65 WARNING **WARNING:** This product can expose you to chemicals including **Lead and Lead Compounds** which are known to the State of California to cause cancer and birth defects or other reproductive harm. For more information go to www.P65Warnings.ca.gov



Regular Check

A comprehensive check must take precedence if it coincides with a regular check.

A regular check is intended only to demonstrate the STO is functional. It will not always detect the loss of a single channel. It is therefore important for the user and / or machinery builder to determine the frequency of the comprehensive checks based on their knowledge and application of the machine.

The following tests should be performed:

STO test	Regular Check, Activity	Expected reaction and effect
1	Ensure that no harm can come to personnel or equipment if the motor turns.	
2	Apply +24V DC to terminals X11/01 and X11/03.	No error must be present in the drive system
3	Apply power to the drive.	X11/05 and /06 must be OFF. No error must be present in the drive system.
4	Try to start the drive with a non-zero setpoint. This setpoint value will be referred to as SPT1 for brevity in these tests. Leave this set throughout all tests.	The drive should start and the motor should turn at SPT1. X11/05 and /06 must remain OFF.
5	Remove connections to X11/01 and X11/03 within 1 second of each other.	Drive must stop immediately, and report STO trip. X11/05 and /06 must be ON.
6	Re-apply 24V to X11/01 and X11/03.	STO trip indication must remain. X11/05 and /06 must turn OFF.
7	Try to restart drive.	STO trip indication should clear. Drive must restart at SPT1.
8	Stop the drive. Test is complete.	Drive must stop.

Troubleshooting

Symptom	Examine:			Probable cause	Remedy
	6901 MMI display	User output ⁴	User inputs ⁵		
Drive won't start when given a start command	*** TRIPPED *** SAFE TORQUE OFF	On	Both < 15V	STO is invoked.	When safe to do so, connect X11/01 and X11/03 to 24V ± 10%
	*** TRIPPED *** SAFE TORQUE OFF	Off	Both >15V and < 30V	Fault latch might have tripped	Remove all power from drive and re-apply. If symptom persists, immediately return the 890 for repair. See the DANGER box below.
	Any other trip message, e.g. overvoltage	Off	Both >15V and < 30V	Drive is tripped, but not due to STO.	Reset the trip, and remove its cause. If symptom persists, return the 890 for repair.
	Any other message	Off	Both >15V and < 30V	Faulty hardware	Return for repair
Drives starts unexpectedly	Don't care	Don't care	Both < 5V	Faulty hardware	Immediately return the 890 for repair. See the DANGER box below.
	Don't care	Off	Both > 5V	STO not invoked by the user.	Use STO according to instructions elsewhere in this chapter.
Drive fails comprehensive or regular STO test	Don't care	Don't care	Don't care	Faulty hardware	Immediately return the 890 for repair. See the DANGER box below.

The above table is only a guide. It may not be a comprehensive list of all possible symptoms relating to STO. Parker Hannifin Manufacturing will not accept responsibility for any consequences arising from its incompleteness or inaccuracy.

⁴ Continuity through X11/05 and X11/06

⁵ Measure X11/01 and X11/03 relative to X11/02 or X11/04

⚠ PROP 65 WARNING **WARNING:** This product can expose you to chemicals including **Lead and Lead Compounds** which are known to the State of California to cause cancer and birth defects or other reproductive harm. For more information go to www.P65Warnings.ca.gov



Important note:

- There are no user-serviceable parts in the 890 drive. Refer to the Safety Warnings and Limitations section of this chapter.

DANGER

IF ANY FAULTY OPERATION OF THE STO FUNCTION IS OBSERVED OR SUSPECTED, OPERATION OF THE 890 SHOULD CEASE IMMEDIATELY AND THE UNIT SHOULD BE RETURNED TO PARKER HANNIFIN MANUFACTURING FOR INVESTIGATION AND REPAIR. FAILURE TO DO SO COULD RESULT IN INJURY, DEATH OR DAMAGE.

FURTHER OPERATION OF THE 890 WITHOUT RESOLVING THIS FAILURE IS ENTIRELY AT THE USER'S OWN RISK.

SEE SAFETY CATEGORY DEFINITIONS AND LIMITATIONS. REFER TO EN ISO 13849-1:2008

 **PROP 65 WARNING** **WARNING:** This product can expose you to chemicals including **Lead and Lead Compounds** which are known to the State of California to cause cancer and birth defects or other reproductive harm. For more information go to www.P65Warnings.ca.gov

HAS Diagnostics



WELCOME
SCREEN



OPERATOR menu at
level 1



Res Temp(F)
= XX



Hrs of Operation
= XX



CAL PSI
= XX



HAS Position =
 XX .00

Display of HAS Reservoir Temperature
 Note: Thermistor must be connected for operation

Display of HAS operating hours
 Display in hours, recorded with minimum 3 secs of operation time.

Display of Pump pressure calculated from amp draw, pump displacement and Motor kT constant.

Display of HAS position, units defined by value entered in Position @ 100% input field.

HAS specific keypad displayed fields located in the Operator menu. These fields are read only.

⚠ PROP 65 WARNING **WARNING:** This product can expose you to chemicals including **Lead and Lead Compounds** which are known to the State of California to cause cancer and birth defects or other reproductive harm. For more information go to www.P65Warnings.ca.gov

6901 Keypad LED Indications



- OFF
- FLASH
- ON

The LEDs are labelled HEALTH, LOCAL (as SEQ and REF), RUN, STOP, FWD and REV. Combinations of these LEDs have the following meanings:

HEALTH	RUN	STOP	Drive State
<input checked="" type="checkbox"/>	<input checked="" type="checkbox"/>	<input checked="" type="checkbox"/>	Re-Configuration
<input checked="" type="checkbox"/>	<input type="checkbox"/>	<input checked="" type="checkbox"/>	Tripped
<input checked="" type="checkbox"/>	<input type="checkbox"/>	<input checked="" type="checkbox"/>	Stopped
<input checked="" type="checkbox"/>	<input type="checkbox"/>	<input checked="" type="checkbox"/>	Stopping
<input checked="" type="checkbox"/>	<input checked="" type="checkbox"/>	<input type="checkbox"/>	Running with zero speed demand or enable false or contactor feedback false
<input checked="" type="checkbox"/>	<input checked="" type="checkbox"/>	<input type="checkbox"/>	Running
<input checked="" type="checkbox"/>	<input checked="" type="checkbox"/>	<input type="checkbox"/>	Running
<input checked="" type="checkbox"/>	<input checked="" type="checkbox"/>	<input checked="" type="checkbox"/>	Autotuning
<input checked="" type="checkbox"/>	<input checked="" type="checkbox"/>	<input checked="" type="checkbox"/>	Auto Restarting, waiting for trip cause to clear
<input checked="" type="checkbox"/>	<input checked="" type="checkbox"/>	<input type="checkbox"/>	Auto Restarting, timing

Alert Message Displays

A message will be displayed on the Keypad when either:

- A requested operation is not allowed:
The top line details the illegal operation, while the bottom line gives the reason or cause. See example opposite.
- The drive has tripped:
The top line indicates a trip has occurred while the bottom line gives the reason for the trip. See example opposite.

* KEY INACTIVE *
 REMOTE SEQ

* * * TRIPPED * *
 * HEATSINK TEMP

Most messages are displayed for only a short period, or for as long as an illegal operation is tried, however, trip messages must be acknowledged by pressing the **E** key.

Password Protection (6901 Keypad)

When activated, the password prevents unauthorized parameter modification by making all parameters “read-only”. If you attempt to modify a password protected parameter, you will be prompted for the password.

The password protection is activated/deactivated using the PASSWORD parameter.

To Activate Password Protection

By default the password feature is deactivated, i.e. 0000.

1. Enter a new password in the PASSWORD parameter (anything other than the default value of 0000), for example 0002.
2. Press the **E** key repeatedly until the Welcome screen is displayed. Pressing the **E** key again activates password protection.

MMI Menu Map

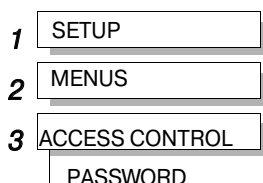

Note Perform a **SAVE CONFIG** if you need the

password to be saved on power-down.

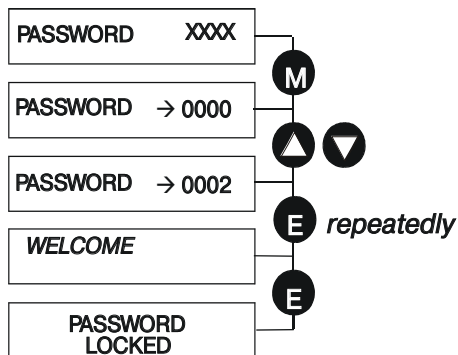

HAS Operator Menu



6511 Display	6901 Display	
OP 1 HAS SPEED SETPOINT	Speed Command (xxxxxx)	<i>Units %</i> Read Only
OP 2 Establishes limits for pump operation. See Page __ for details	Pump Disp-CC	Range: 1 to 12 (2-12 cc Valid) Default Value: 1 (cc)
OP 3 Mode 0 internal speed setting See Page ____ for Details	HAS Speed (V1)	Range: 0 to 100 % Default Value: 50%
OP 4 (V2) Mode 0 internal speed setting for Motion Profiler input See Page ____ for Details	HAS Speed	Range: 0 to 100 % Default Value: 50%
OP 5 HAS acceleration ramp time from zero to maximum pump speed . See Page __ for details	HAS Accel (R1)	Range: 0.1 to 5 seconds Default Value: 0.3 sec
OP 6 HAS deceleration ramp time form maximum pump speed to zero See Page ____ for Details	HAS Speed (V1)	Range: 0.1 to 5 seconds Default Value: 0.3 sec

Note: Not all entry have keypad limits, entry values outside range listed will be clamped at either minimum or maximum entry

⚠ PROP 65 WARNING **WARNING:** This product can expose you to chemicals including **Lead and Lead Compounds** which are known to the State of California to cause cancer and birth defects or other reproductive harm. For more information go to www.P65Warnings.ca.gov





6511 Display	6901 Display	
<p>OP 7</p> <p>Configuration of Off state of Limit Switches See Page __ for details</p>	<p>L-Switch NC</p>	<p><i>Range: True/False</i></p> <p><i>Default Value: False</i></p>
<p>OP 8</p> <p>Alignment of pump rotation with Inputs and Controls See Page ____ for Details</p>	<p>Invert Direction</p>	<p><i>Range: True/False</i></p> <p><i>Default Value: False</i></p>
<p>OP 9</p> <p>Selection of desired Valve Type operation See Page __ for details</p>	<p>HAS Mode</p>	<p><i>Range: – 0 to 4</i></p> <p><i>Default Value: – 0</i></p>
<p>OP 10</p> <p>Enables analog position feedback device to establish position control limits See Page ____ for Details</p>	<p>Stop On Position</p>	<p><i>Range: True/False</i></p> <p><i>Default Value: False</i></p>
<p>OP 11</p> <p>Enables Stopping motion based upon calculated PSI value See Page ____ for Details</p>	<p>Stop On PSI</p>	<p><i>Range: True/False</i></p> <p><i>Default Value: False</i></p>
<p>OP 12</p> <p>Position value at 10V input signal, used to calibrate control and display units See Page ____ for Details</p>	<p>Position at 100%</p>	<p><i>Range: 0.00 to 100.00</i></p> <p><i>Default Value: 10.00</i></p>

Note: Not all entry have keypad limits, entry values outside range listed will be clamped at either minimum or maximum entry

⚠ PROP 65 WARNING **WARNING:** This product can expose you to chemicals including **Lead and Lead Compounds** which are known to the State of California to cause cancer and birth defects or other reproductive harm. For more information go to www.P65Warnings.ca.gov





6511 Display	6901 Display	
OP 13	POS STP High	<i>Range: 0.00 to 100.00</i> <i>Default Value: 10.00</i>
Position value that stops motion in extend direction of HAS See Page ___ for Details		
OP 14	Pos STP Low	<i>Range: 0.00 to 100.00</i> <i>Default Value: 1.00</i>
Position value that stops motion in retract direction of HAS See Page ___ for Details		
OP 15	CW STP PSI	<i>Range: 500-3000 Default Value: 1000 PSI</i>
Calculated pressure in PSI that stops clockwise pump rotation See Page __ for details		
OP 16	CCW STP PSI	<i>Range: 500-3000 Default Value: 1000 PSI</i>
Calculated pressure in PSI that stops counterclockwise clockwise pump rotation See Page ___ for details		
OP 17	CW STP Time	<i>Range: 0.3 to 5 secs</i> <i>Default Value: 3 second</i>
Time value calculated PSI maintained before clockwise pump rotation stops See Page __ for details		
OP 18	CCW STP Time	<i>Range: 0.3 to 5 secs</i> <i>Default Value: 3 second</i>
Time value calculated PSI maintained before counter-clockwise pump rotation stops See Page ___ for details		

Note: Not all entry have keypad limits, entry values outside range listed will be clamped at either minimum or maximum entry

⚠ PROP 65 WARNING **WARNING:** This product can expose you to chemicals including **Lead and Lead Compounds** which are known to the State of California to cause cancer and birth defects or other reproductive harm. For more information go to www.P65Warnings.ca.gov





6511 Display	6901 Display	
OP 19 Mode 4, minimum pump speed setting, default is set for closed loop control. See Page ___ for Details	Min SPD Mode 4	Range: 100 to 600 Default Value: 100 RPM
OP 20 Mode 4 analog input dead band adjustment. See Page ___ for Details	Deadband Mode 4	Range: 0.1 to 10.00 % Default Value: 1.00%
OP 21 When equipped with level switch, setting True, will Trip Drive on Low Oil Level See Page __ for details	Low Level Trip	Range: True/False Default Value: False
OP 22 When set True, Drive will trip when Reservoir Temp exceeds, 158 F See Page ___ for details	Over Temp Trip	Range: True/False Default Value: False
OP 23 HAS Units ordered with Heat Exchanger option, relay output to activate control. See Page __ for details	Cooler Control	Range: True/False Default Value: False
OP 24 Temperature value that activates cooling loop control See Page __ for details	Cool/Heater On (F)	Range: 50 to 140 (F) Default Value: 140 (F)

Note: Not all entry have keypad limits, entry values outside range listed will be clamped at either minimum or maximum entry

⚠ PROP 65 WARNING **WARNING:** This product can expose you to chemicals including **Lead and Lead Compounds** which are known to the State of California to cause cancer and birth defects or other reproductive harm. For more information go to www.P65Warnings.ca.gov





6511 Display	6901 Display	
OP 25		
Reserved		
OP 26	Res Temp (F)	<i>Read Only Units: Temp (F)</i>
Display of Reservoir Temperature See Page ___ for Details		
OP 27	Hours of Operation	<i>Read Only Units: 0.1 Hours</i>
Display of Operational Hours See Page __ for details		
OP 28	Reset Hours	<i>Range: True/False Default Value: False</i>
Resets hours display to zero value, requires password entry. See Page ___ for details		
OP 29	Calculated PSI	<i>Read Only Units: Pressure (PSI)</i>
Display of calculated HAS Pressure See Page __ for details		
OP 30	HAS Position	<i>Read Only Units: User Defined</i>
When equipped with feedback, display of position value See Page ___ for details		

Note: Not all entry have keypad limits, entry values outside range listed will be clamped at either minimum or maximum entry

⚠ PROP 65 WARNING **WARNING:** This product can expose you to chemicals including **Lead and Lead Compounds** which are known to the State of California to cause cancer and birth defects or other reproductive harm. For more information go to www.P65Warnings.ca.gov



The DIAGNOSTIC Menu

DIAGNOSTIC MENU			
PREF	6511 Display	6901 Display	
101.09	d 1 Indicates actual speed demand. This is the input to the frequency controller. <i>(Refer to the REFERENCE function block)</i>	SPEED DEMAND	Range: —.xx %
101.01	d 2 This is the target reference that the drive will ramp to in remote reference mode (not including trim), direction is taken from REFERENCE::REMOTE REVERSE and the sign of REMOTE SETPOINT. <i>(Refer to the REFERENCE function block)</i>	REMOTE SETPOINT	Range: —.xx %
101.14	d 3 This setpoint is the target reference that the drive will ramp to in Remote Reference Comms mode (not including trim). The direction is always positive, i.e. forward. <i>(Refer to the REFERENCE function block)</i>	COMMS SETPOINT	Range: —.xx %
101.12	d 4 Indicates the Keypad setpoint. It is always a positive quantity; saved on power down. Direction is taken from LOCAL REVERSE. <i>(Refer to the REFERENCE function block)</i>	LOCAL SETPOINT	Range: —.xx %
103.01	d 5 The setpoint is the target reference that the drive will ramp to in Jog Reference mode. <i>(Refer to the REFERENCE JOG function block)</i>	(JOG) SETPOINT	Range: —.xx %

⚠ PROP 65 WARNING **WARNING:** This product can expose you to chemicals including **Lead and Lead Compounds** which are known to the State of California to cause cancer and birth defects or other reproductive harm. For more information go to www.P65Warnings.ca.gov



DIAGNOSTIC MENU		
PREF	6511 Display	6901 Display
78.17	d 6 The final value of speed demand obtained after summing all sources in rpm. <i>(Refer to the SPEED LOOP function block)</i>	TOTL SPD DMD RPM <i>Range: —.xx rpm</i>
78.18	d 7 The final value of speed demand obtained after summing all sources as a percentage of MAX SPEED CLAMP (REFERENCE function block). <i>(Refer to the SPEED LOOP function block)</i>	TOTAL SPD DMD % <i>Range: —.xx %</i>
70.04	d 8 The mechanical speed of the motor shaft in revolutions per minute. <i>(Refer to the FEEDBACKS function block)</i>	SPEED FBK RPM <i>Range: —.xx rpm</i>
70.06	d 9 Shows the mechanical speed of the motor shaft as a percentage of MAX SPEED CLAMP (REFERENCE function block). <i>(Refer to the FEEDBACKS function block)</i>	SPEED FBK % <i>Range: —.xx %</i>
78.19	d 11 The difference between the demanded speed and the actual speed. <i>(Refer to the SPEED LOOP function block)</i>	SPEED ERROR <i>Range: —.xx %</i>
73.04	d 12 Shows the drive output frequency in Hz. <i>(Refer to the PATTERN GEN function block)</i>	DRIVE FREQUENCY <i>Range: —.xx Hz</i>

⚠ PROP 65 WARNING **WARNING:** This product can expose you to chemicals including **Lead and Lead Compounds** which are known to the State of California to cause cancer and birth defects or other reproductive harm. For more information go to www.P65Warnings.ca.gov



DIAGNOSTIC MENU			
PREF	6511 Display	6901 Display	
78.21	<input type="text" value="d 13"/>	DIRECT INPUT	Range: —.xx % <i>(Refer to the SPEED LOOP function block)</i>
The value of the direct input, after scaling and clamping.			
78.16	<input type="text" value="d 14"/>	TORQ DMD ISOLATE	Range: FALSE / TRUE <i>(Refer to the SPEED LOOP function block)</i>
Speed Control mode and Torque Control mode selection. Torque Control mode = TRUE.			
83.05	<input type="text" value="d 15"/>	ACTUAL POS LIM	Range: —.xx % <i>(Refer to the TORQUE LIMIT function block)</i>
The final actual positive torque limit as a percentage of rated motor torque.			
83.06	<input type="text" value="d 16"/>	ACTUAL NEG LIM	Range: —.xx % <i>(Refer to the TORQUE LIMIT function block)</i>
The final actual negative torque limit as a percentage of rated motor torque.			
78.07	<input type="text" value="d 17"/>	AUX TORQUE DMD	Range: —.xx % <i>(Refer to the SPEED LOOP function block)</i>
The auxiliary motor torque as a percentage of rated motor torque as a percentage of rated motor torque.			
78.20	<input type="text" value="d 18"/>	TORQUE DEMAND	Range: —.xx % <i>(Refer to the SPEED LOOP function block)</i>
The demanded motor torque as a percentage of rated motor torque.			

⚠ PROP 65 WARNING **WARNING:** This product can expose you to chemicals including **Lead and Lead Compounds** which are known to the State of California to cause cancer and birth defects or other reproductive harm. For more information go to www.P65Warnings.ca.gov



DIAGNOSTIC MENU

PREF	6511 Display	6901 Display	
70.10	d 19	TORQUE FEEDBACK	Range: —.xx % The estimated motor torque, as a percentage of rated motor torque. <i>(Refer to the FEEDBACKS function block)</i>
70.11	d 20	FIELD FEEDBACK	Range: —.xx % A value of 100% indicates the motor is operating at rated magnetic flux (field). <i>(Refer to the FEEDBACKS function block)</i>
70.12	d 23	MOTOR CURRENT %	Range: —.xx % This diagnostic contains the level of rms line current being drawn from the drive and is seen as a % of the MOTOR CURRENT parameter setting in the MOTOR INDUCTION function block. <i>(Refer to the FEEDBACKS function block)</i>
70.13	d 24	MOTOR CURRENT A	Range: —.xx A This diagnostic contains the level of rms line current being drawn from the drive. <i>(Refer to the FEEDBACKS function block)</i>
70.02	d 25	DC LINK VOLTS	Range: —.xx V The internal dc voltage tested across the DC link capacitors. <i>(Refer to the FEEDBACKS function block)</i>
70.03	d 26	TERMINAL VOLTS	Range: —.xx V This shows the rms voltage, between phases, applied by the drive to the motor terminals. <i>(Refer to the FEEDBACKS function block)</i>

▲ PROP 65 WARNING **WARNING:** This product can expose you to chemicals including **Lead and Lead Compounds** which are known to the State of California to cause cancer and birth defects or other reproductive harm. For more information go to www.P65Warnings.ca.gov



DIAGNOSTIC MENU		
PREF	6511 Display	6901 Display
99.06	d 31 A read-only parameter indicating the state of the dynamic brake switch. <i>(Refer to the DYNAMIC BRAKING function block)</i>	BRAKING <i>Range: FALSE / TRUE</i>
73.04	d 32 The drive output frequency in Hertz. <i>(Refer to the PATTERN GEN function block)</i>	DRIVE FREQUENCY <i>Range: —.xx Hz</i>
97.05	d 33 Indicates which trips are currently active. These parameters are a coded representation of the trip status. <i>(Refer to the TRIPS STATUS function block)</i>	ACTIVEWORD 1 <i>Range: 0000 to FFFF</i>
97.06	d 34 Indicates which trips are currently active. These parameters are a coded representation of the trip status. <i>(Refer to the TRIPS STATUS function block)</i>	ACTIVEWORD 2 <i>Range: 0000 to FFFF</i>
97.09	d 35 From when a trip occurs until that trip is reset, this parameter indicates the trip source. When several trips have occurred, this parameter indicates the first one that was detected. <i>(Refer to the TRIPS STATUS function block)</i>	FIRST TRIP <i>Range: Enumerated - refer to block</i>

⚠ PROP 65 WARNING **WARNING:** This product can expose you to chemicals including **Lead and Lead Compounds** which are known to the State of California to cause cancer and birth defects or other reproductive harm. For more information go to www.P65Warnings.ca.gov



DIAGNOSTIC MENU			
PREF	6511 Display	6901 Display	
96.01	d 36 Records the most recent trip that caused the drive to stop.	TRIP 1 (NEWEST)	Range: Enumerated - refer to block <i>(Refer to the TRIPS STATUS function block)</i>
96.02	d 37 Records the second most recent trip that caused the drive to stop.	TRIP 2	Range: Enumerated - refer to block <i>(Refer to the TRIPS STATUS function block)</i>
96.03	d 38 Records the third most recent trip that caused the drive to stop.	TRIP 3	Range: Enumerated - refer to block <i>(Refer to the TRIPS STATUS function block)</i>
96.04	d 39 Records the fourth most recent trip that caused the drive to stop.	TRIP 4	Range: Enumerated - refer to block <i>(Refer to the TRIPS STATUS function block)</i>
96.05	d 40 Records the fifth most recent trip that caused the drive to stop.	TRIP 5	Range: Enumerated - refer to block <i>(Refer to the TRIPS STATUS function block)</i>
96.06	d 41 Records the sixth most recent trip that caused the drive to stop.	TRIP 6	Range: Enumerated - refer to block <i>(Refer to the TRIPS STATUS function block)</i>

⚠ PROP 65 WARNING **WARNING:** This product can expose you to chemicals including **Lead and Lead Compounds** which are known to the State of California to cause cancer and birth defects or other reproductive harm. For more information go to www.P65Warnings.ca.gov



DIAGNOSTIC MENU			
PREF	6511 Display	6901 Display	
96.07	d 42 Records the seventh most recent trip that caused the drive to stop.	TRIP 7	Range: Enumerated - refer to block <i>(Refer to the TRIPS STATUS function block)</i>
96.08	d 43 Records the eighth most recent trip that caused the drive to stop.	TRIP 8	Range: Enumerated - refer to block <i>(Refer to the TRIPS STATUS function block)</i>
96.09	d 44 Records the ninth most recent trip that caused the drive to stop.	TRIP 9	Range: Enumerated - refer to block <i>(Refer to the TRIPS STATUS function block)</i>
96.10	d 45 Records the tenth most recent trip that caused the drive to stop.	TRIP 10 (OLDEST)	Range: Enumerated - refer to block <i>(Refer to the TRIPS STATUS function block)</i>
1.06	d 46 (VALUE) The input reading.	ANALOG INPUT 1	Range: —.xx % <i>(Refer to the ANALOG INPUT function block)</i>
2.06	d 47 (VALUE) The input reading.	ANALOG INPUT 2	Range: —.xx % <i>(Refer to the ANALOG INPUT function block)</i>

⚠ PROP 65 WARNING **WARNING:** This product can expose you to chemicals including **Lead and Lead Compounds** which are known to the State of California to cause cancer and birth defects or other reproductive harm. For more information go to www.P65Warnings.ca.gov



DIAGNOSTIC MENU			
PREF	6511 Display	6901 Display	
3.06	<input type="text" value="d 48"/> (VALUE) The input reading.	ANALOG INPUT 3	Range: —.xx % <i>(Refer to the ANALOG INPUT function block)</i>
4.06	<input type="text" value="d 49"/> (VALUE) The input reading.	ANALOG INPUT 4	Range: —.xx % <i>(Refer to the ANALOG INPUT function block)</i>
5.06	<input type="text" value="d 50"/> (VALUE) The input reading (ANIN1 - ANIN2).	ANALOG INPUT 5	Range: —.xx % <i>(Refer to the ANALOG INPUT function block)</i>
8.02	<input type="text" value="d 51"/> (VALUE) The TRUE or FALSE input.	DIGITAL INPUT 1	Range: FALSE / TRUE <i>(Refer to the DIGITAL INPUT function block)</i>
9.02	<input type="text" value="d 52"/> (VALUE) The TRUE or FALSE input.	DIGITAL INPUT 2	Range: FALSE / TRUE <i>(Refer to the DIGITAL INPUT function block)</i>
10.02	<input type="text" value="d 53"/> (VALUE) The TRUE or FALSE input.	DIGITAL INPUT 3	Range: FALSE / TRUE <i>(Refer to the DIGITAL INPUT function block)</i>

⚠ PROP 65 WARNING **WARNING:** This product can expose you to chemicals including **Lead and Lead Compounds** which are known to the State of California to cause cancer and birth defects or other reproductive harm. For more information go to www.P65Warnings.ca.gov



DIAGNOSTIC MENU			
PREF	6511 Display	6901 Display	
11.02	d 54 (VALUE) The TRUE or FALSE input.	DIGITAL INPUT 4	Range: FALSE / TRUE <i>(Refer to the DIGITAL INPUT function block)</i>
12.02	d 55 (VALUE) The TRUE or FALSE input.	DIGITAL INPUT 5	Range: FALSE / TRUE <i>(Refer to the DIGITAL INPUT function block)</i>
13.02	d 56 (VALUE) The TRUE or FALSE input.	DIGITAL INPUT 6	Range: FALSE / TRUE <i>(Refer to the DIGITAL INPUT function block)</i>
14.02	d 57 (VALUE) The TRUE or FALSE input.	DIGITAL INPUT 7	Range: FALSE / TRUE <i>(Refer to the DIGITAL INPUT function block)</i>
15.02	d 58 (VALUE) The TRUE or FALSE input.	DIGITAL INPUT 8	Range: FALSE / TRUE <i>(Refer to the DIGITAL INPUT function block)</i>
16.02	d 59 (VALUE) The TRUE or FALSE input.	DIGITAL INPUT 9	Range: FALSE / TRUE <i>(Refer to the DIGITAL INPUT function block)</i>

⚠ PROP 65 WARNING **WARNING:** This product can expose you to chemicals including **Lead and Lead Compounds** which are known to the State of California to cause cancer and birth defects or other reproductive harm. For more information go to www.P65Warnings.ca.gov



DIAGNOSTIC MENU			
PREF	6511 Display	6901 Display	
6.01	d 60 (VALUE) The demanded value to output.	ANALOG OUTPUT 1	Range: —.xx % <i>(Refer to the ANALOG OUTPUT function block)</i>
7.01	d 61 (VALUE) The demanded value to output.	ANALOG OUTPUT 2	Range: —.xx % <i>(Refer to the ANALOG OUTPUT function block)</i>
17.01	d 62 (VALUE) The TRUE or FALSE output demand.	DIGITAL OUTPUT 1	Range: FALSE / TRUE <i>(Refer to the DIGITAL OUTPUT function block)</i>
18.01	d 63 (VALUE) The TRUE or FALSE output demand.	DIGITAL OUTPUT 2	Range: FALSE / TRUE <i>(Refer to the DIGITAL OUTPUT function block)</i>
19.01	d 64 (VALUE) The TRUE or FALSE output demand.	DIGITAL OUTPUT 3	Range: FALSE / TRUE <i>(Refer to the DIGITAL OUTPUT function block)</i>

⚠ PROP 65 WARNING **WARNING:** This product can expose you to chemicals including **Lead and Lead Compounds** which are known to the State of California to cause cancer and birth defects or other reproductive harm. For more information go to www.P65Warnings.ca.gov



Trips

What Happens when a Trip Occurs

When a trip occurs, the drive’s power stage is immediately disabled causing the motor and load to coast to a stop. The trip is latched until action is taken to reset it. This ensures that trips due to transient conditions are captured and the drive is disabled, even when the original cause of the trip is no longer present

Drive Indications

If a trip condition is detected the unit displays and performs the following actions.

1. The programming block SEQ & REF::SEQUENCING LOGIC::TRIPPED signal is set to TRUE.
2. The FIRST TRIP parameter in the TRIPS STATUS function block displays the trip ID. Refer to Chapter 9: "Keypad Menus" - DISABLED WORD 1, DISABLED WORD 2 for a table of enumerated values..

Keypad Indications (when connected)

If a trip condition is detected the MMI displays and performs the following actions.

1. The trip source is displayed on the keypad.
2. 6901 keypad only: the HEALTH LED on the Keypad flashes indicating a trip condition has occurred and a trip message is displayed stating the cause of the trip.
3. The trip message(s) must be acknowledged by pressing the **STOP** key. The trip message may be cleared by pressing the **E** key. Refer to ___: "The Keypad" - Alert Message Displays.

To reset a trip on keypad:

Remove the trip condition



Press the Stop key to clear the trip. You can now press Run to restart the system.

Remove the trip condition

-

Alternatively, remove and re-apply the 24V supply at X01, or toggle the ENABLE to 0V and then 24V to restart the system.

Trips Table

The following Warning may occur to protect the drive and HAS System.



6511 Keypad Display	6901 Keypad Display	Description	Possible Reason for Warning
A 1	Reservoir over T	HAS Reservoir Over Temp	<ul style="list-style-type: none"> ◆ System duty cycle too high, heat exchanger required ◆ HAS Relief PSI setting too low, operating at relief setting
A 2	Oil Change Req	HAS Oil change Required	<ul style="list-style-type: none"> ◆ System has exceeded the recommended 8000 hours of operation. Service Required.
A 3	Low Oil Level	Low Level Condition	<ul style="list-style-type: none"> ◆ When fitted with low level switch, trip conditions low HAS oil operating level
A 4	Temp Sens Fault	HAS Low Level Condition	<ul style="list-style-type: none"> ◆ Reservoir Temp not installed or cut cable ◆ Damaged Reservoir Sensor

Default settings for above are warnings only, they will not prohibit operating of the HAS unit. Their purpose is to warn the user of possible damage. Low level and High Temp conditions may be change to Trip drive. Keypad 6511 will display same code regardless of Warning or Trip. 6901 will indicate Warning or Trip on Top line of display. see page 71 for details.

⚠ PROP 65 WARNING **WARNING:** This product can expose you to chemicals including **Lead and Lead Compounds** which are known to the State of California to cause cancer and birth defects or other reproductive harm. For more information go to www.P65Warnings.ca.gov

Trips Table

The following trips may occur to protect the drive.



6511 Keypad Display	6901 Keypad Display	Description	Possible Reason for Trip
DCHI	OVERVOLTAGE	The drive internal dc link voltage is too high	<ul style="list-style-type: none"> ◆ The supply voltage is too high ◆ Trying to decelerate a large inertia load too quickly ◆ The brake resistor is open circuit
DCLO	UNDERVOLTAGE	The drive internal dc link voltage is too low	<ul style="list-style-type: none"> ◆ The supply voltage is too low ◆ The supply has been lost ◆ A supply phase is missing

⚠ PROP 65 WARNING **WARNING:** This product can expose you to chemicals including **Lead and Lead Compounds** which are known to the State of California to cause cancer and birth defects or other reproductive harm. For more information go to www.P65Warnings.ca.gov



6511 Keypad Display	6901 Keypad Display	Description	Possible Reason for Trip
OC	OVERCURRENT	The motor current being drawn from the drive is too high	<ul style="list-style-type: none"> ◆ Pressure too high ◆ Pump too big ◆ Application error ◆ Short circuit between motor phases ◆ Short circuit between motor phase and earth
STO	SAFE TORQUE OFF	Safe Torque Off (STO) is active.	<ul style="list-style-type: none"> ◆ One or both STO user inputs is low ◆ A fault has been detected in the STO circuit
HOT	HEATSINK	The drive heatsink temperature is too high	<ul style="list-style-type: none"> ◆ The ambient air temperature is too high ◆ Poor ventilation or spacing between drives
ET	EXTERNAL TRIP	User trip caused via control terminals	<ul style="list-style-type: none"> ◆ +24V not present on external trip (terminal X15/05) ◆ Check setting of EXT TRIP MODE parameter

PROP 65 WARNING **WARNING:** This product can expose you to chemicals including **Lead and Lead Compounds** which are known to the State of California to cause cancer and birth defects or other reproductive harm. For more information go to www.P65Warnings.ca.gov





6511 Keypad Display	6901 Keypad Display	Description	Possible Reason for Trip
IN 1	INPUT 1 BREAK	I/O TRIPS:: INPUT 1 BREAK has gone True	◆ Check configuration to determine source of signal
IN 2	INPUT 2 BREAK	I/O TRIPS:: INPUT 2 BREAK has gone True	◆ Check configuration to determine source of signal
STLL	MOTOR STALLED	The motor has stalled (not rotating)	<ul style="list-style-type: none"> ◆ Motor loading too great ◆ Current limit level is set too low ◆ Stall trip duration is set too low ◆ Fixed or auto boost levels are set too high
IT	INVERSE TIME		◆ The inverse time current limit is active: motor loading is too great; fixed or auto boost levels are too high (Full Load Current = 150% for 60 seconds)
DB R	BRAKE RESISTOR	External dynamic braking resistor has been overloaded	◆ Trying to decelerate a large inertia load too quickly or too often
DB S	BRAKE SWITCH	Internal dynamic braking switch has been overloaded	◆ Trying to decelerate a large inertia load too quickly or too often

⚠ PROP 65 WARNING **WARNING:** This product can expose you to chemicals including **Lead and Lead Compounds** which are known to the State of California to cause cancer and birth defects or other reproductive harm. For more information go to www.P65Warnings.ca.gov

Trip Table



6511 Keypad Display	6901 Keypad Display	Description	Possible Reason for Trip
DISP	OP STATION	Keypad has been disconnected from drive whilst drive is running in local control	◆ Keypad accidentally disconnected from drive
SCI	COMMS BREAK		◆ COMMS BREAK parameter set to True (refer to I/O TRIPS menu at level 3)
CNTC	CONTACTOR FBK		◆ The CONTACTOR CLOSED input in the SEQUENCING LOGIC function block remained FALSE after a run command was issued
SPD	SPEED FEEDBACK		◆ SPEED ERROR > 50.00% for 10 seconds
AOT	AMBIENT TEMP		◆ The ambient temperature in the drive is too high

PROP 65 WARNING **WARNING:** This product can expose you to chemicals including **Lead and Lead Compounds** which are known to the State of California to cause cancer and birth defects or other reproductive harm. For more information go to www.P65Warnings.ca.gov





6511 Keypad Display	6901 Keypad Display	Description	Possible Reason for Trip
OT	MOTOR OVERTEMP	The motor temperature is too high	<ul style="list-style-type: none"> ◆ Excessive load ◆ Motor voltage rating incorrect ◆ FIXED BOOST and/or AUTO BOOST set too high ◆ Prolonged operation of the motor at low speed without forced cooling ◆ Check setting of INVERT THERMIST parameter in I/O TRIPS menu at level 3. ◆ Break in motor thermistor connection
A24SC	24V FAILURE	The 24V customer output has fallen below 17V	<ul style="list-style-type: none"> ◆ 24V customer output is short circuited ◆ Excessive loading

⚠ PROP 65 WARNING **WARNING:** This product can expose you to chemicals including **Lead and Lead Compounds** which are known to the State of California to cause cancer and birth defects or other reproductive harm. For more information go to www.P65Warnings.ca.gov



6511 Keypad Display	6901 Keypad Display	Description	Possible Reason for Trip
LSPD	LOW SPEED OVER I	The motor is drawing too much current (>100%) at zero output frequency	◆ FIXED BOOST and/or AUTO BOOST set too high (refer to FLUXING menu at level 3)
PHAS	PHASE FAIL		◆ One or more input phases not present
ENC 1	FBK ENCODER FAIL		◆ Encoder fault
SHRT	DESAT (OVER I)		◆ Instantaneous overcurrent. Refer to OVERCURRENT in this table
DCRP	VDC RIPPLE		◆ The dc link ripple voltage is too high. Check for a missing input phase.
DBSC	BRAKE SHORT CCT	Brake resistor overcurrent	◆ Check brake resistance is not less than minimum value allowed ◆ check wiring and brake resistor for earth faults
OSPD	OVERSPEED		◆ Speed feedback > 150% for 0.1 seconds
ANIN	ANALOG INPUT ERR		◆ 4-20mA analog input current > 22mA could damage the input circuit

▲ PROP 65 WARNING **WARNING:** This product can expose you to chemicals including **Lead and Lead Compounds** which are known to the State of California to cause cancer and birth defects or other reproductive harm. For more information go to www.P65Warnings.ca.gov



6511 Keypad Display	6901 Keypad Display	Description	Possible Reason for Trip
DBCT	INT DB RESISTOR		◆ Braking mode set to INTERNAL (future use only). Set to EXTERNAL and connect an External Braking Resistor if braking is required.
TRIP	UNKNOWN		◆ An unknown trip - refer to Parker Hannifin Manufacturing
TR32	OTHER		◆ Refer to OTHER in Appendix D: TRIPS STATUS. One or more trips have occurred with a Value greater than 32. See the list.
ATN1	MAX SPEED LOW		◆ During Autotune the motor is required to run at the nameplate speed of the motor. If MAX SPEED RPM limits the speed to less than this value, an error will be reported. Increase the value of MAX SPEED RPM up to the nameplate rpm of the motor (as a minimum). It may be reduced, if required, after the Autotune is complete.
ATN2	MAINS VOLTS LOW		◆ The mains input voltage is not sufficient to carry out the Autotune. Re-try when the mains have recovered.

⚠ PROP 65 WARNING **WARNING:** This product can expose you to chemicals including **Lead and Lead Compounds** which are known to the State of California to cause cancer and birth defects or other reproductive harm. For more information go to www.P65Warnings.ca.gov



Trip Table



6511 Keypad Display	6901 Keypad Display	Description	Possible Reason for Trip
ATN 3	NOT AT SPEED		◆ The motor was unable to reach the required speed to carry out the Autotune. Possible reasons include: motor shaft not free to turn; the motor data is incorrect
ATN4	MAG CURRENT FAIL		◆ It was not possible to find a suitable value of magnetizing current to achieve the required operating condition for the motor. Check the motor data is correct, especially nameplate rpm and motor volts. Also check that the motor is correctly rated for the drive.
ATN5	NEGATIVE SLIP F		◆ Autotune has calculated a negative slip frequency, which is not valid. Nameplate rpm may have been set to a value higher than the base speed of the motor. Check nameplate rpm, base frequency, and pole pairs are correct.
ATN6	TR TOO LARGE		◆ The calculated value of rotor time constant is too large. Check the value of nameplate rpm.
ATN7	TR TOO SMALL		◆ The calculated value of rotor time constant is too small. Check the value of nameplate rpm.

PROP 65 WARNING **WARNING:** This product can expose you to chemicals including **Lead and Lead Compounds** which are known to the State of California to cause cancer and birth defects or other reproductive harm. For more information go to www.P65Warnings.ca.gov



6511 Keypad Display	6901 Keypad Display	Description	Possible Reason for Trip
ATN8	MAX RPM DATA ERR		<ul style="list-style-type: none"> This error is reported when the MAX SPEED RPM is set to a value outside the range for which Autotune has gathered data. Autotune gathers data on the motor characteristics up to 30% beyond “max speed rpm”. If MAX SPEED RPM is later increased beyond this range, the drive had no data for this new operating area, and so will report an error. To run the motor beyond this point it is necessary to re-autotune with MAX SPEED RPM set to a higher value.
STAC	STACK TRIP		<ul style="list-style-type: none"> The drive was unable to distinguish between an overcurrent/desat or overvoltage trip
ATNA	LEAKGE L TIMEOUT		<ul style="list-style-type: none"> The leakage inductance measurement requires a test current to be inserted into the motor. It has not been possible to achieve the required level of current. Check that the motor is wired correctly.
	PLOS POWER LOSS STOP		<ul style="list-style-type: none"> Power Loss Stop sequence has ramped Speed Setpoint to zero or timed out
ATNC	MOTR TURNING ERR		<ul style="list-style-type: none"> The motor must be stationary when starting the Autotune

⚠ PROP 65 WARNING **WARNING:** This product can expose you to chemicals including **Lead and Lead Compounds** which are known to the State of California to cause cancer and birth defects or other reproductive harm. For more information go to www.P65Warnings.ca.gov





6511 Keypad Display	6901 Keypad Display	Description	Possible Reason for Trip
ATND	MOTR STALLED ERR		◆ The motor must be able to rotate during Autotune
ATNE	AT TORQ LIM ERR		◆ The motor is in torque limit during Autotune
ECAL	FBK ENCODR CAL	The drive has failed to set absolute position	◆ Check the encoder supports absolute position, and that the encoder is wired correctly.
GEAR	OUTPUT GBX ERROR		◆ A non-unity output gearbox is not supported if the encoder direction is reversed.
APP	APP HALTED		◆ The application has been halted by the DSE Configuration Tool
AERR	APP ERROR		◆ The application has ceased execution due to an error
FERR	FIRMWARE ERROR		◆ The firmware in the drive has stopped executing

PROP 65 WARNING **WARNING:** This product can expose you to chemicals including **Lead and Lead Compounds** which are known to the State of California to cause cancer and birth defects or other reproductive harm. For more information go to www.P65Warnings.ca.gov





6511 Keypad Display	6901 Keypad Display	Description	Possible Reason for Trip
RSLV	RESOLVER ERROR	See function block description	<ul style="list-style-type: none"> ◆ Resolver disconnected ◆ Resolver incorrectly wired ◆ Resolver not compatible with resolver feedback option board ◆ Resolver length cable too long ◆ Incorrect Resolver Function Block settings
MI2T	I2T MOTOR TRIP	See function block description	◆ Motor is undersized
STO	SAFE TORQUE OFF	-	◆ The safe torque off feature has been activated. See Chapter 6, STO Trip Annunciation.
DCFG	DRIVE CONFIG ERR	Drive configuration error	◆ The configuration defined in DRIVE CONFIG doesn't match the actual drive configuration.
CT1	Reservoir Over T	Reservoir Over Temp	◆ HAS Reservoir exceed 158F and Trip on Temp set in config
CT2	Low Oil Level	Oil Level Low	◆ HAS Reservoir level low and Trip on Low Level set in config

⚠ PROP 65 WARNING **WARNING:** This product can expose you to chemicals including **Lead and Lead Compounds** which are known to the State of California to cause cancer and birth defects or other reproductive harm. For more information go to www.P65Warnings.ca.gov





6511 Keypad Display	6901 Keypad Display	Description	Possible Reason for Trip
DCHI	OVERVOLTAGE	The shared dc link voltage is too high	The supply voltage is too high Trying to decelerate a large inertia load too quickly The brake resistor is open circuit
OC	OVERCURRENT	The current being drawn from the drive is too high	
HOT	HEATSINK	The heatsink temperature is too high	
IT	INVERSE TIME	High output current for prolonged period, (warning only)	
DISP	DISPLAY / KEYPAD	Keypad has been disconnected from drive whilst drive is running in local control	Loose connection to display
SCI	LOST COMMS	Not used	Refer to Parker Hannifin technical support

PROP 65 WARNING **WARNING:** This product can expose you to chemicals including **Lead and Lead Compounds** which are known to the State of California to cause cancer and birth defects or other reproductive harm. For more information go to www.P65Warnings.ca.gov





6511 Keypad Display	6901 Keypad Display	Description	Possible Reason for Trip
T 6	24V FAILURE	The 24V customer output has fallen below 17V	Refer to Parker Hannifin technical support
T 4	VOLTS SEL SWITCH	Failure to read voltage selector switch	May be caused by excessive loading on ANOUT
PHAS	PHASE LOSS	Input phase missing	
CHRG	CHARGING	Failed to charge DC link	Excessive capacitance on DC link Short circuit on DC link
DCRP	VDC RIPPLE	Excessive DC link ripple	Driving a reciprocating load
AOUT	ANOUT FAULT	Overload on analog output	
VOLT	VOLTS SELECTION	Invalid position on volts selector switch	
ENCI	ENC NEEDS INIT	PMAC motor used with a relative encoder – Needs to run init once per power cycle	Relative encoder needs to be aligned with the motor back EMF. Use MOT POLARISATION feature to align

⚠ PROP 65 WARNING **WARNING:** This product can expose you to chemicals including **Lead and Lead Compounds** which are known to the State of California to cause cancer and birth defects or other reproductive harm. For more information go to www.P65Warnings.ca.gov



6511 Keypad Display	6901 Keypad Display	Description	Possible Reason for Trip
	COMMS FAULT CODE N	The drive has not responded to a message from the 6901	Drive CPU busy.
	COMMS FAULT CODE C	Incorrect reply from drive following a selection (command) message from the 6901	Unexpected, due to electrical interference
	COMMS FAULT CODE P	Parity error in message received from the drive by the 6901	
	COMMS FAULT CODE F	Format of message received from the drive by the 6901 is incorrect	
	COMMS FAULT CODE B	BCC (block check character) in message received from the drive by the 6901 is incorrect	
	COMMS FAULT CODE L	Length of message received from the drive by the 6901 is incorrect (too many characters)	

PROP 65 WARNING WARNING: This product can expose you to chemicals including **Lead and Lead Compounds** which are known to the State of California to cause cancer and birth defects or other reproductive harm. For more information go to www.P65Warnings.ca.gov



DSE Lite Installation

The 890 Drive is supplied with a CD containing the DSE Lite Configuration Tool. The install file is also available at www.localizedpower.com

Insert the CD and execute the "setup.exe" file on the disk to install the latest LINK database and DSE Lite. Follow the on-screen instructions.



Installing the Texas Instruments USB driver, for an 890 drive.

This driver is compatible with 32 and 64 bit versions of Windows.

The DSE installation program will copy the Texas Instruments USB driver files to the directory: C:\Program Files (x86)\Texas Instruments\USB-Serial Adapter\TUSB3410. **To install this driver run the 'Setup.exe' in the above directory.** The driver is then installed in the directory 'Windows\tiinst\TUSB3410'

When the 890 drive is connected to the computer for the first time, Windows pops up with the "Found New Hardware Wizard". The driver should install automatically. If it doesn't, disconnect and reconnect the USB cable and or cycle power to the computer.

Verification of USB driver.

Make sure that the USB cable is connected to the 890 drive and to the computer. To determine which com port is being used and to determine if the USB driver is operating properly, go to: My Computer (Right Click) → Properties → Hardware → Device Manager

When the Device Manager window appears, go to: Ports (COM & LPT1) → TUSB3410 Device (COMx) as shown in the picture. In this example Com 3 is being used. There should only be 1 instance of this driver installed on the pc and it needs to be in the Ports menu only, nowhere else.

To determine if the driver is operating properly, right mouse click, on the TUSB3410 DEVICE and go to PROPERTIES. Then go to the GENERAL Tab and view the DEVICE STATUS. It should say: This device is working properly. Then go to the DRIVER Tab and verify the DRIVER VERSION: 6.7.2.0

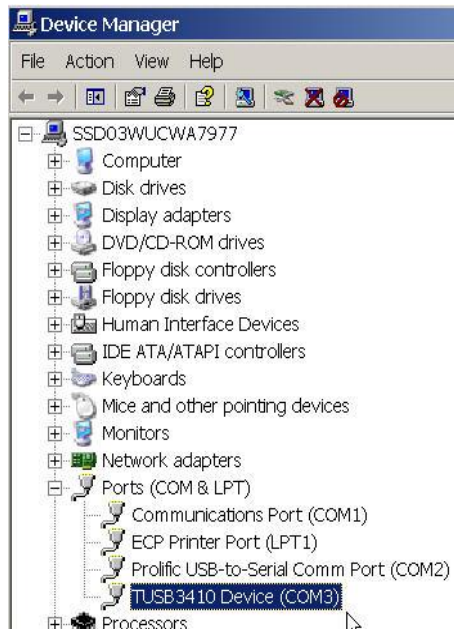

Then launch DSE and click on the yellow Serial Port icon and select the correct COM as shown in this example on the right.

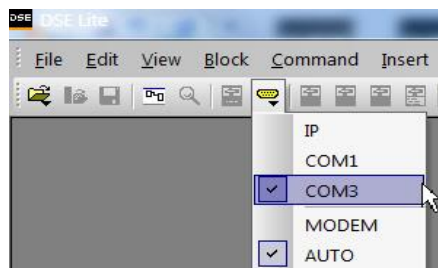

DSE – Click on this icon, for COM port

PROP 65 WARNING WARNING: This product can expose you to chemicals including **Lead and Lead Compounds** which are known to the State of California to cause cancer and birth defects or other reproductive harm. For more information go to www.P65Warnings.ca.gov

Launching DSE Lite

Start DSE Lite by clicking its program icon in Windows or, in the Windows' Start Menu click on "All Programs", you will see "SSD Drives", and within is "DSE Lite". Click on this to launch DSE Lite.

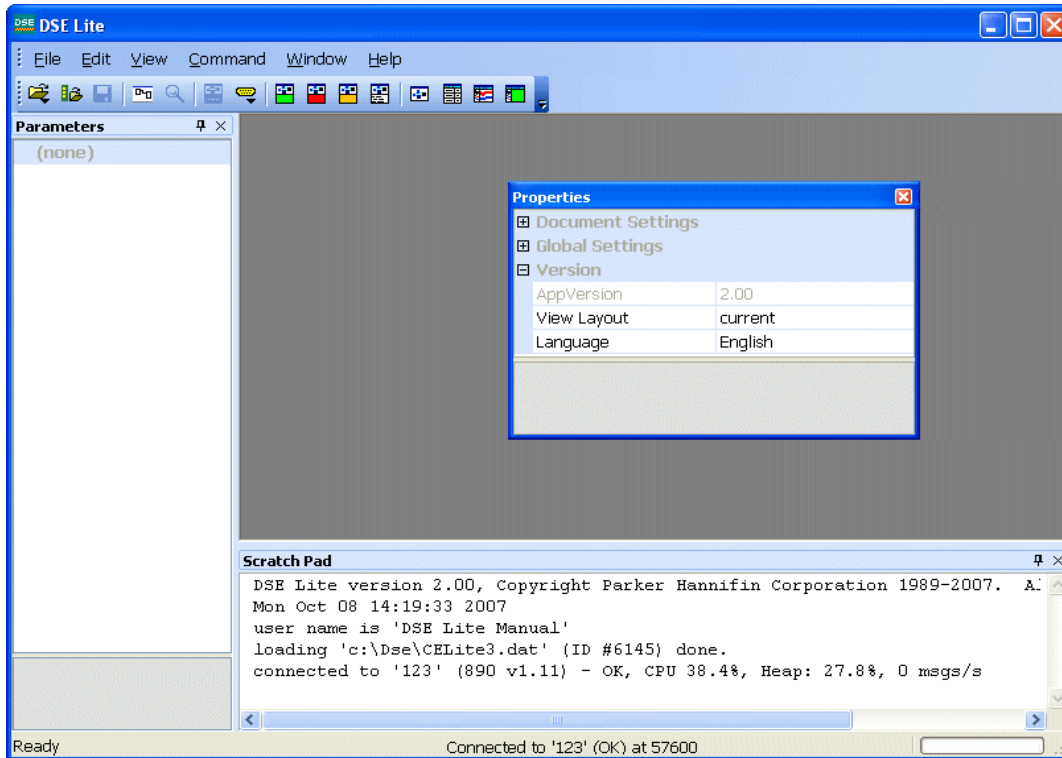

PROP 65 WARNING WARNING: This product can expose you to chemicals including **Lead and Lead Compounds** which are known to the State of California to cause cancer and birth defects or other reproductive harm. For more information go to www.P65Warnings.ca.gov

Connecting to the Drive

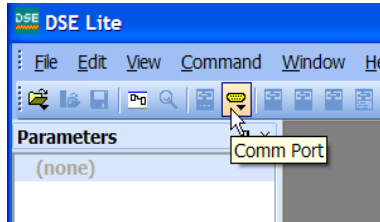

There are now two ways to connect to a drive, USB cable, and Ethernet.

The Comm Port icon is shown on the Left, and the drop down menu is shown on the left.

USB Cable Connection

At this point the only drive that can use the USB connection is the 890 Drive. The USB cable is a standard type A to mini-B, which should not be longer than 3 meters and of good quality shielded cable. Connect the A connector to any open USB port on the computer and the mini-b connector to the drive's X10 terminal. For a multiple drive systems linked via Firewire, please refer to the DSE software manual.

In the Comm Port drop down list, there are two things that need to be setup for USB communications; Comm port and baud rate. Make sure there is a check mark next to the port number that matches the port setup at the beginning of this chapter. The baud rate should have a check mark next to Auto.

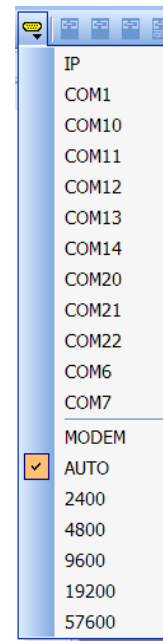

WARNING

Make sure all components on the system are properly grounded, BEFORE connecting any cables to the drive or computer. Failure to properly ground the system will result in damage to the drive, computer and cables.

PROP 65 WARNING **WARNING:** This product can expose you to chemicals including **Lead and Lead Compounds** which are known to the State of California to cause cancer and birth defects or other reproductive harm. For more information go to www.P65Warnings.ca.gov

Communication with Drive

When connected and communicating with the drive, the file name will be listed in the connected box, located in lower right hand corner of the main window

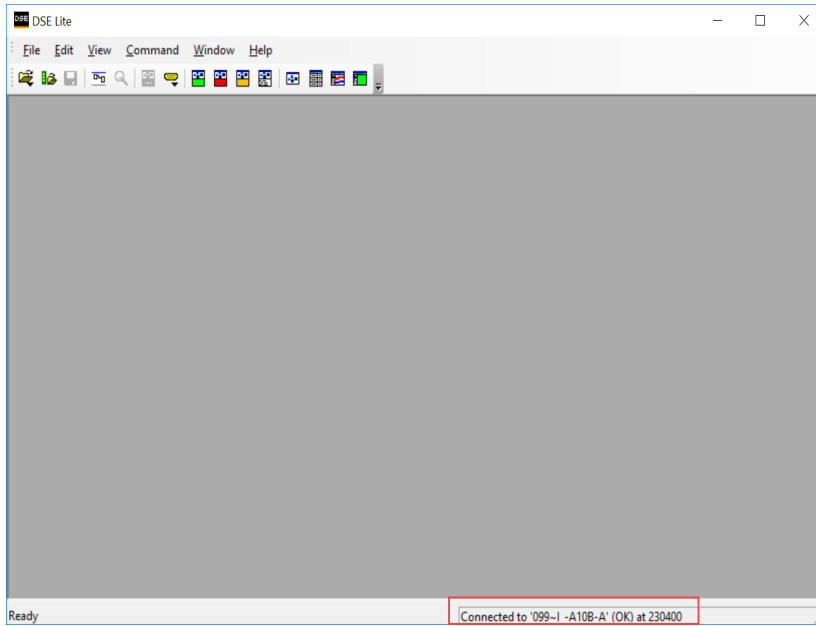

Extracting the Program

When ordering HAS Drive kits, they are delivered with programs loaded. If the Base Program is altered, it may be desired to extract the program for file storage and future use. The program can be extracted by using the EXTRACT command located in the File Pull Down Menu

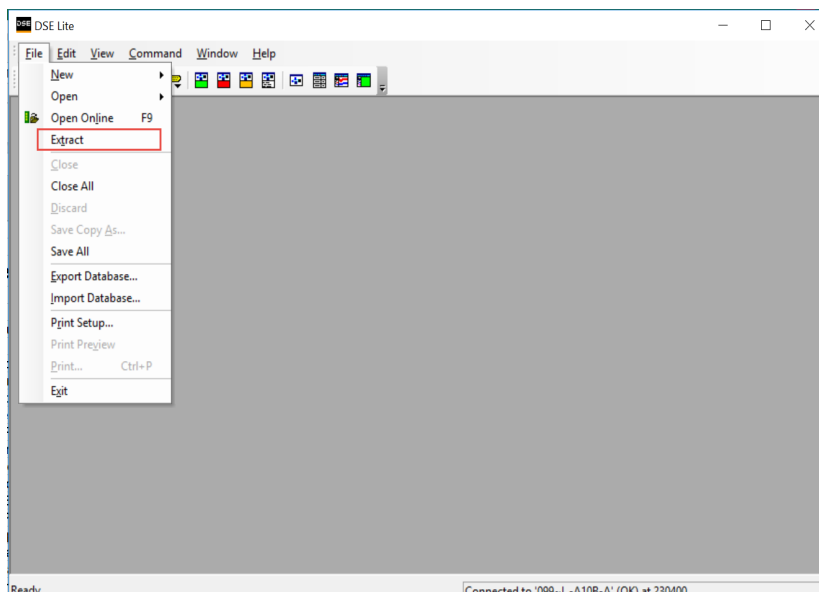

⚠ PROP 65 WARNING **WARNING:** This product can expose you to chemicals including **Lead and Lead Compounds** which are known to the State of California to cause cancer and birth defects or other reproductive harm. For more information go to www.P65Warnings.ca.gov

Online Diagnostics

Once the drive is connected, you may open the program Online to monitor activity, messages and other interactions with the drive. This is accomplished by either pressing the F9 key on your PC or using the File pull down menu and selecting Open Online.

Note You cannot remove or add blocks and links in **ONLINE mode**.

The ONLINE configuration window has "ONLINE" displayed in the title, but otherwise the window looks the same as the OFFLINE version, but it does have some extra features.

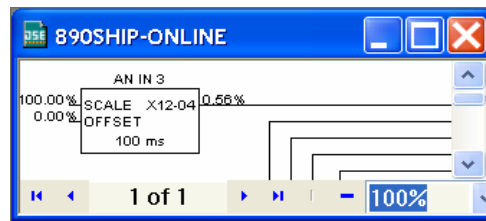
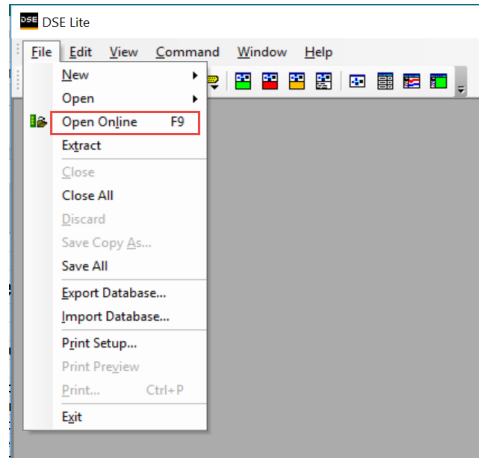

- Click the input or output of a block to display the actual value from the drive in the Scratchpad.
- SHIFT-click the output of a block to add that parameter to the Monitor List.
- CTRL-click the input of a block to change the parameter value. This will bring up a dialog prompting for the value to be set.
- Right-click a parameter to display a menu of actions applying to the parameter (right-clicking a parameter in the Parameters View has the same effect): **Get** Display the parameter value in the Scratchpad.

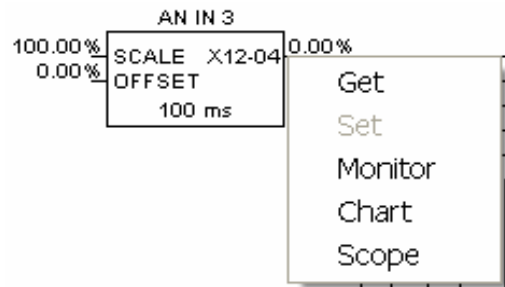

- Monitor** Add this parameter to the Monitor List
- Chart** Add this parameter to the Chart
- Scope** Recorder Add this parameter to the Oscilloscope.

Note that in all cases the Scratchpad will display the latest value.

The Monitor List

The Monitor List displays all the drive parameters that you are monitoring and continuously gets updated values from the drive.

You can easily remove a parameter from the Monitor List by a right click and selecting "Delete".





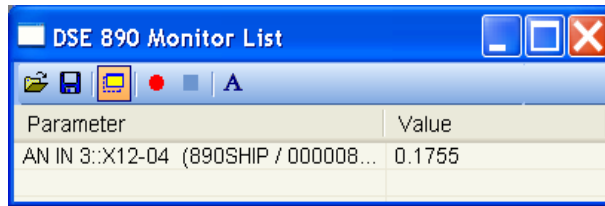

"Set", available for this parameter, brings up a dialog to change the value. Enable and Disable allow this parameter to enabled or disabled from being updated in the Monitor List.

"Parameter" displays the configuration name/instance/parameter name

"Value" displays the current value, constantly updated.



Tool Bar

-  Open saved Monitor List configuration from a file.
-  Save Monitor List configuration to a file.
-  Toggle the Monitor List to be on top.
-  Start recording to a file.
-  Stop recording.
-  Change the font of the items in the monitor list.

The Chart Recorder

The Chart Recorder displays the values of the selected parameter(s) and continuously gets updated values from the drive.

"Settings" displays the settings for how the chart recorder displays the information.

Time Base [s]; This is the time period shown by the chart (x axis)

Chart Mode: When False the chart redraws at the end of the time range; when True the chart scrolls continuously







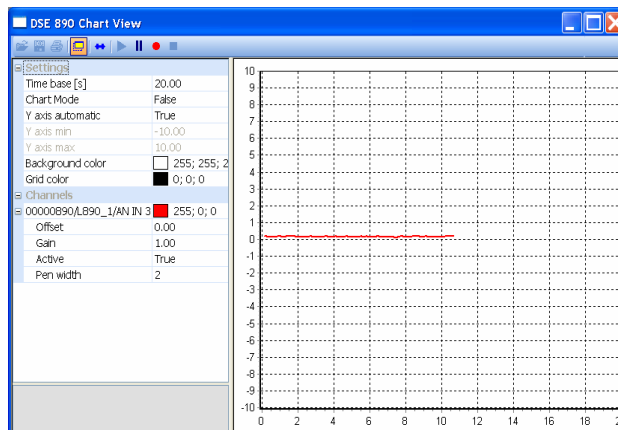

Y axis automatic: When False the Y axis is set by "Y axis min" and "Y axis max"; when True the Y axis is set automatically

Y Axis Min/Max: Sets the minimum and maximum Y axis for the chart

Background /Grid Color: Background and Foreground color of the chart



Tool Bar

-  Open saved oscilloscope configuration from a file.
-  Save captured oscilloscope data and configuration. Print oscilloscope plot.
-  Toggle the Chart Recorder to be on top.
-  Display/Hide the property grid.
-  Restart data acquisition.
-  Pause data acquisition.
-  Start recording to a file.
-  Stop recording.

**NEVER do a Full Install !!
 Control + G or INSTALL ONLY**

HAS Analog Discrete Programmed Drive

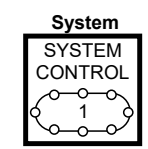
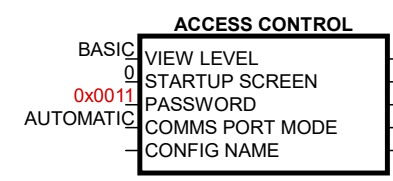
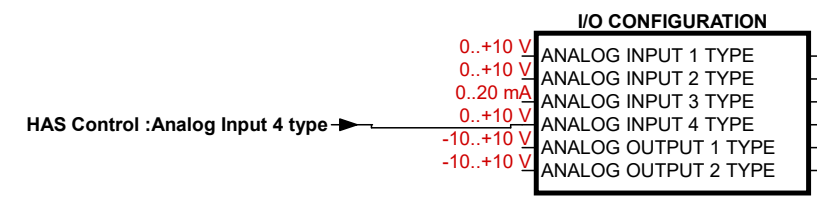
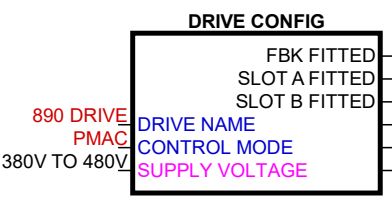
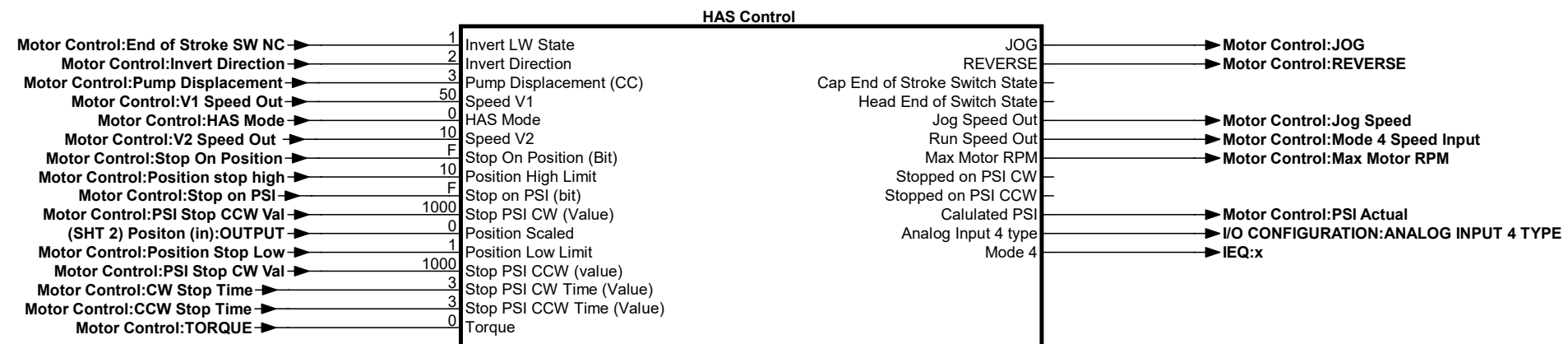
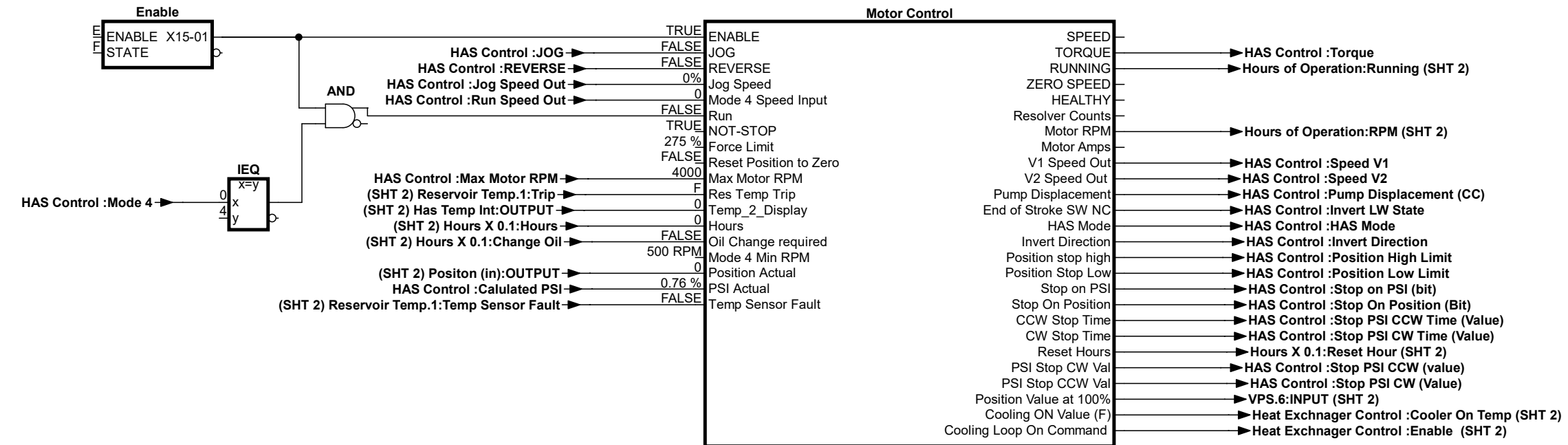

Localized Power Parker Cylinder Divison-Des Plaines, IL 60016 (847) 298-2400 www.parker.com/cylinder	DWN BBESCH 03/21/19	Hybrid Actuator Series HAS 500	SIZE A DWG. NO.	RF0991760***-00A
	CHK	099176***00-A/1/099-00-BASE.316	ISSUE	
	APP		SCALE	SHEET 1 OF 2
	EDIT	LOC		

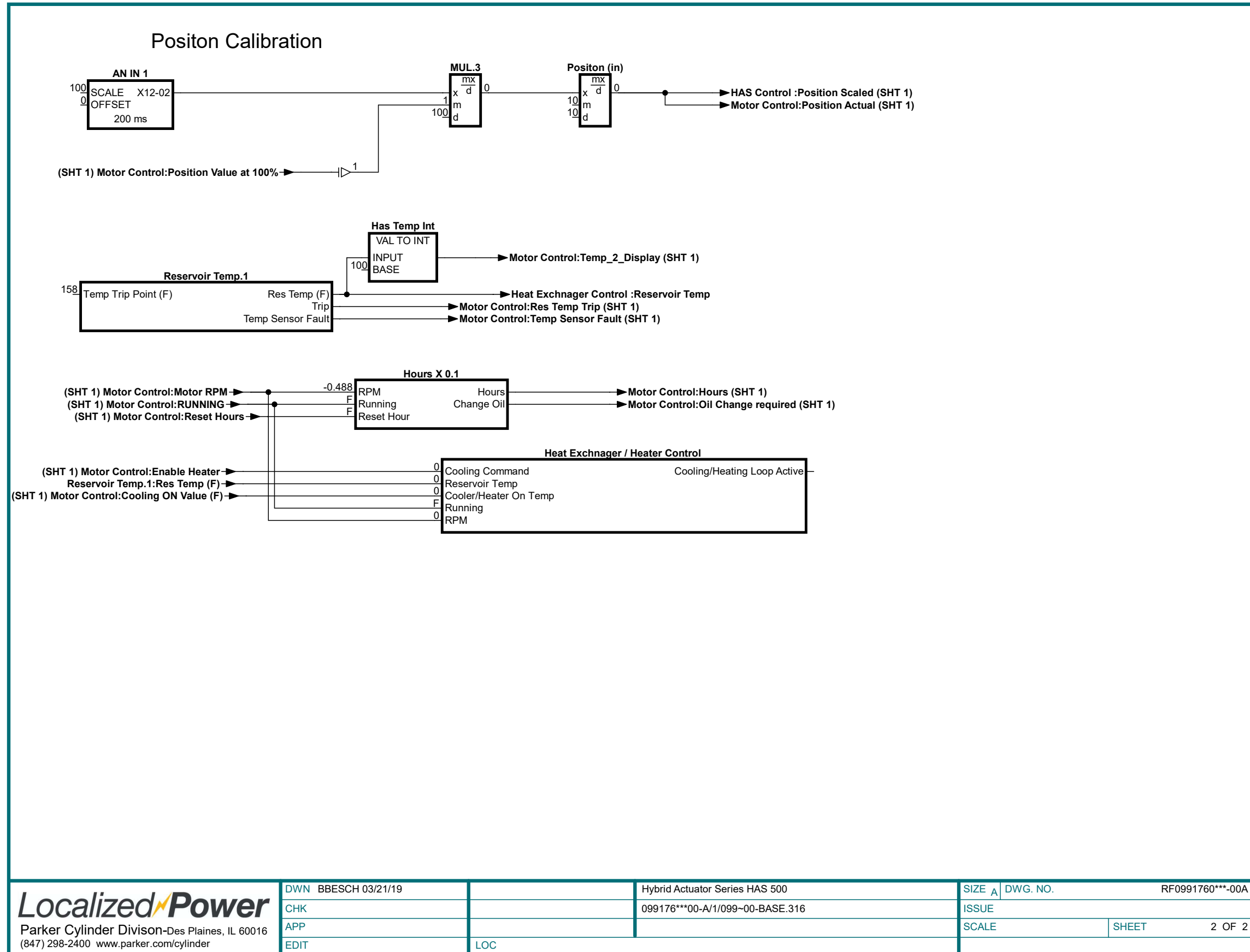

Frame B Drive Specifications

890SD Standalone Drive									
Input currents are listed at 230Vac 50Hz, 400Vac 50Hz, and 460Vac 60Hz.									
Motor power, input current and output current ratings must not be exceeded under steady state operating conditions.									
Vector Mode 150% overload for 60 seconds. Servo Mode 200% overload for 4 seconds.									
FRAME B Short circuit current rating of supply: 5000A.									
Model Number	890SD/2/0003B	890SD/2/0005B	890SD/2/0007B	890SD/2/0011B	890SD/2/0016B				
Nominal Supply Voltage Vac	230								
Motor Power kW/Hp	0.55/0.75	1.1/1.5	1.5/2	2.2/3	4/5				
Input Current - Vector Mode A	4.2	7.7	9.3	15.2	21.8				
Output Current - 3kHz Vector Mode A	3	5.5	7	11	16.5				
Output Current - 4kHz Servo Mode A	2.2	4	6	8	12				
Minimum External Braking Resistor Ω	36	36	36	36	22				
Model Number	890SD/5/0002B		890SD/5/0003B		890SD/5/0004B		890SD/5/0006B		
Nominal Supply Voltage Vac	400	460-500	400	460-500	400	460-500	400	460-500	
Motor Power kW/Hp	0.55kW	0.75Hp	1.1kW	1.5Hp	1.5kW	2Hp	2.2kW	3Hp	
Input Current - Vector Mode A	2.9	2.8	5	4.9	6.8	6.5	9.0	7.2	
Output Current - 3kHz Vector Mode A	2	2	3.5	3.5	4.5	4.5	6	5	
Output Current - 4kHz Servo Mode A	1.5	1.5	2.5	2.5	3.5	3.5	4	4	
Minimum External Braking Resistor Ω	100	100	100	100	100	100	100	100	
Model Number	890SD/5/0010B		890SD/5/0012B		890SD/5/0016B		890SD/5/S0016B		
Nominal Supply Voltage Vac	400	460-500	400	460-500	400	460-500	400	460-500	
Motor Power kW/Hp	4kW	5Hp	5.5kW	7.5Hp	7.5kW	10Hp	7.5kW	10Hp	
Input Current - Vector Mode A	14	11.1	16.5	16.1	21.7	18.7	23.4*	20.9*	
Output Current - 3kHz Vector Mode A	10	8	12	12	16	14	-	-	
Output Current - 4kHz Servo Mode A	6	6	9	9	12	10	16	14	
Minimum External Braking Resistor Ω	100	100	56	56	56	56	56	56	
* Values are for "Input Current - Servo Mode".									

230V Nominal Supply Power is 200 to 264Vac

HAS Unit configuration defaults if 4 kHz Servo Mode

No braking resistor required if equipped with load holding~ counterbalance valves.

PROP 65 WARNING WARNING: This product can expose you to chemicals including **Lead and Lead Compounds** which are known to the State of California to cause cancer and birth defects or other reproductive harm. For more information go to www.P65Warnings.ca.gov



Frame C and D Drive Specifications

890SD Standalone Drive

Input currents are listed at 230Vac 50Hz, 400Vac 50Hz, and 460Vac 60Hz.

Motor power, input current and output current ratings must not be exceeded under steady state operating conditions.

Vector Mode 150% overload for 60 seconds. Servo Mode 200% overload for 4 seconds.

FRAME C Short circuit current rating of supply: 10000A.									
Model Number		890SD/2/0024C	890SD/2/0030C	890SD/5/0024C	890SD/5/0030C	890SD/5/S030C			
Nominal Supply Voltage	Vac	230	230	400	460-500	400	460-500	400	460-500
Motor Power	kW/Hp	5.5/7.5	7.5/10	11kW	15Hp	15kW	20Hp	15kW	20Hp
Input Current - Vector Mode	A	31	40	32	27	40	34	40	34
Output Current - 3kHz Vector Mode	A	24	30	24	24	30	27	30	30
Output Current - 4kHz Servo Mode	A	24	30	20	20	25	22	30	28
Minimum External Braking Resistor	Ω	15	12	36	36	30	30	25	25
FRAME D Short circuit current rating of supply: 10000A.									
Model Number		890SD/5/0039D		890SD/5/0045D		890SD/5/0059D			
Nominal Supply Voltage	Vac	400	460-500	400	460-500	400	460-500		
Motor Power	kW/Hp	18.5kW	25Hp	22kW	30Hp	30kW	40Hp		
Input Current - Vector Mode	A	42	38	50	45	62	56		
Output Current - 3kHz Vector Mode	A	39	35	45	40	59	52		
Output Current - 4kHz Servo Mode	A	35	29	38	34	50	45		
Minimum External Braking Resistor	Ω	20	20	20	20	15	20		

HAS Unit configuration defaults if 4 kHz Servo Mode

No braking resistor required if equipped with load holding~ counterbalance valves.

⚠ PROP 65 WARNING WARNING: This product can expose you to chemicals including **Lead and Lead Compounds** which are known to the State of California to cause cancer and birth defects or other reproductive harm. For more information go to www.P65Warnings.ca.gov



Resolver Speed Feedback Option

Description

The 8902/RE and 8902/RR Resolver Speed Feedback Options allow resolvers to be connected directly to the motor controller to provide highly accurate speed feedback measurement.

In addition, the 8902/RR provides an emulated pulse encoder output.

Features

The Option has the following features:

- Contains two differential inputs on channels Sin and Cos
- Contains a carrier output signal to power the Resolver
- 8902/RR contains three differential outputs, emulating a pulse encoder.

Part Number

The part number for the Resolver Speed Feedback Option is :

- 8902/RE/00/00
- 8902/RE/00/FF (indicates a factory-fitted Option)
- 8902/RR/00/00
- 8902/RR/00/FF (indicates a factory-fitted Option)

Used On

This Option can be used on 890 drives with the following Product Codes:

- 890SD/.. 890SD Standalone Drive
- 890CD/.. 890CD Common Bus Drive
- 890P.....

Refer to the 890 Engineering Reference Manual, Appendix E for Product Code details.

Note: 8902/RE may be supplied as Style1 or Style 2 (refer Figure 1 and 2).

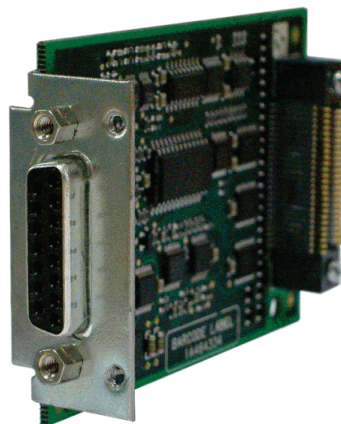

Figure 1 - Style 1: 8902/RE Resolver Speed Feedback Option



Figure 2 – Style 2: 8902/RR Resolver Speed Feedback Option

Specifications – Resolver Interface (8902/RE and 8902/RR)

Maximum Speed	8902/RE: Up to 50,000RPM (with 2 pole resolver) 8902/RR: Up to 30,000RPM (with 2 pole resolver)
Carrier Output Signal	7Vrms, 8kHz
Maximum Carrier	70mA rms
Supply Maximum Input	±12V peak
Voltage Accuracy	< 5 minutes
Resolution	Equivalent to 16 bits per electrical revolution of resolver
Inputs	Differential inputs, Zin ~2 kΩ Maximum input voltage : 12Vpeak
Isolation	None

Specifications – Emulated Encoder (8902/RR only)

Signal amplitude	Compatible with RS422 and RS485
Outputs	3 Differential pairs
Signal nomenclature	A and B quadrature Z index pulse
Number of lines per revolution	1024
Isolation	Outputs are isolated from drive electronics

PROP 65 WARNING **WARNING:** This product can expose you to chemicals including **Lead and Lead Compounds** which are known to the State of California to cause cancer and birth defects or other reproductive harm. For more information go to www.P65Warnings.ca.gov



Fitting the Option

If the Option is not factory-fitted, follow the procedure given below.

WARNING!

Disconnect all sources of power before attempting installation.

Caution

This Option contains ESD (Electrostatic Discharge) sensitive parts. Observe static control precautions when handling, installing and servicing this Option.

1. Undo the two screws securing Option A and Option B to the front of the drive. If Options are not fitted, completely remove the blank covers for the Option A and Option B slots.
2. Undo the screws (A) located in the top and bottom handles of the control board. Gently pull on the handles to withdraw the board from the drive, supporting any attached option boards. Note that the boards are sliding in top and bottom slots.
3. Remove any other Options that are fitted to the control board.
4. Offer up the Resolver Option through the "OPTION F" cut-out as shown opposite.
5. Fit the two locating pegs of the large connector on the rear edge of the option board into the locating holes on the control board, as shown below.
6. Fit the two screws and crinkle washers (C) at the rear edge of the Option. **DO NOT OVERTIGHTEN.** Tightening torque : 0.2Nm (28 oz-in).
7. Secure with the two screws (B) to the front of the control board.
The front panel screws (B) are self-tapping and can be quite hard to turn. This turning torque must not be transferred through the option board to the control board connector. To avoid this hold the option board with one hand, while tightening the front panel screws with the other. DO NOT hold the control board while tightening these screws.
8. Refit any other Options that were removed from the control board.
9. Replace the control board (with attached Options) into the drive.
10. Tighten the Option A and Option B screws; or importantly, fit the blank covers and secure with the screws.

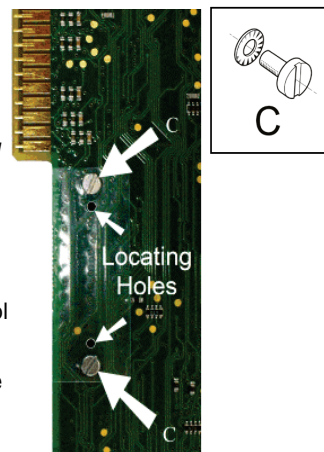
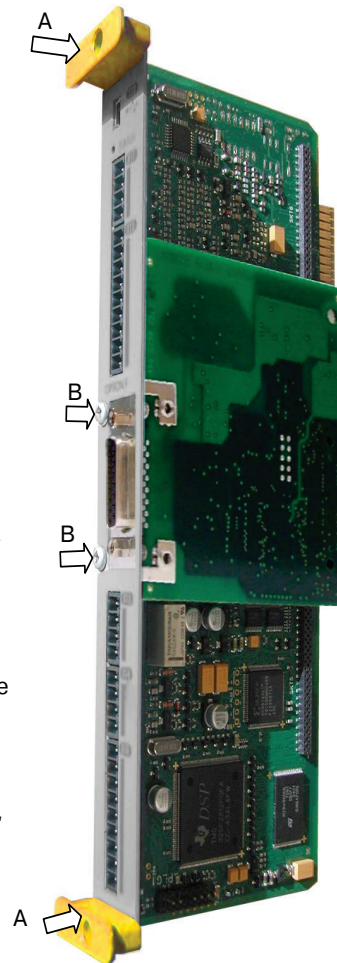

Figure 3 Rear of Control Board

PROP 65 WARNING **WARNING:** This product can expose you to chemicals including **Lead and Lead Compounds** which are known to the State of California to cause cancer and birth defects or other reproductive harm. For more information go to www.P65Warnings.ca.gov

Wiring the System

WARNING!
 Disconnect all sources of power before attempting installation.

Caution

This Option contains ESD (Electrostatic Discharge) sensitive parts. Observe static control precautions when handling, installing and servicing this Option.

D-Type Connections

Note: For correct operation, carrier, sine and cosine **must** be connected as specified. Poor performance/motor behavior may occur if these signals are left unconnected or are connected incorrectly.

Take special care wiring the resolvers to the Option due to the low level of the signals.

Ideally use twisted-pair, screened cable with an overall screen and a screen over each individual pair. It may be possible to use a cable with just a screen over each individual pair. The signal pairs should have characteristic impedance of 120Ω. To ensure compliance with the EMC Directive the overall cable screen should be connected to the connector body and to the cable clamp. Connect overall screen and individual screens together, on each side of the cable.

Use the resolver manufacturer's recommended cable.

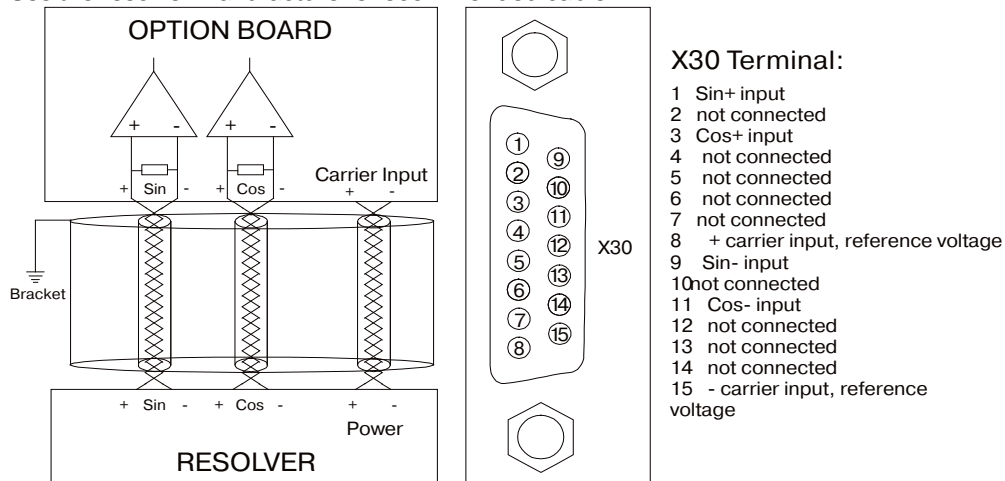

Figure 4 Wiring Diagram 8902/RE

PROP 65 WARNING **WARNING:** This product can expose you to chemicals including **Lead and Lead Compounds** which are known to the State of California to cause cancer and birth defects or other reproductive harm. For more information go to www.P65Warnings.ca.gov

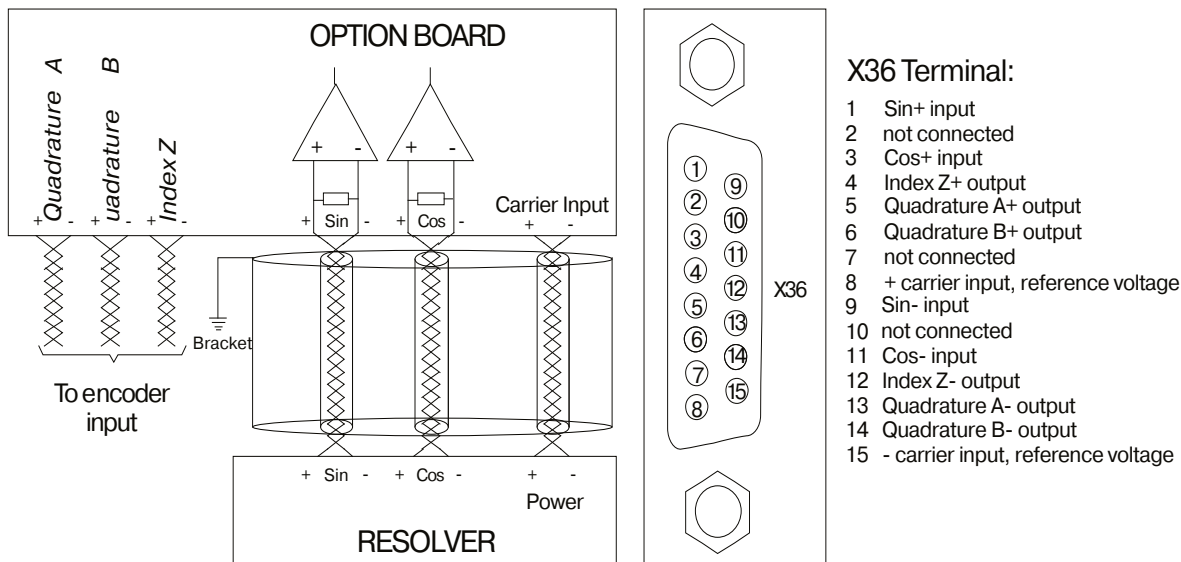
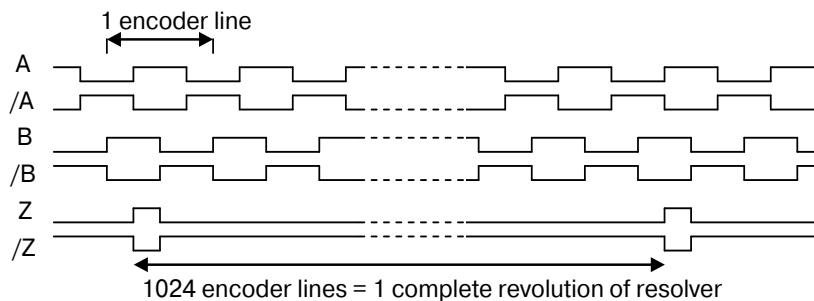

Figure 5 Wiring Diagram 8902/RR

Encoder Emulation

Encoder emulation creates three differential pairs, A, B and Z. These emulate a 1024 line encoder rotating at the same speed and direction as the resolver. Clockwise rotation of the encoder shaft normally causes channel A to lead channel B, but this could reverse depending on the resolver wiring.



PROP 65 WARNING WARNING: This product can expose you to chemicals including **Lead and Lead Compounds** which are known to the State of California to cause cancer and birth defects or other reproductive harm. For more information go to www.P65Warnings.ca.gov

Motor Phasing

The control of PMAC brushless motors is allowed if the relative position between the stator and the rotor is well known. The resolver must be set up to define the relative position between the resolver and the 3 motor phases. For the 890 drive, the convention is as follows :

- ◆ when the motor runs in a clockwise direction, looking to the front shaft of the motor, the 3 successive phases are M1, M2 and M3 as shown below.

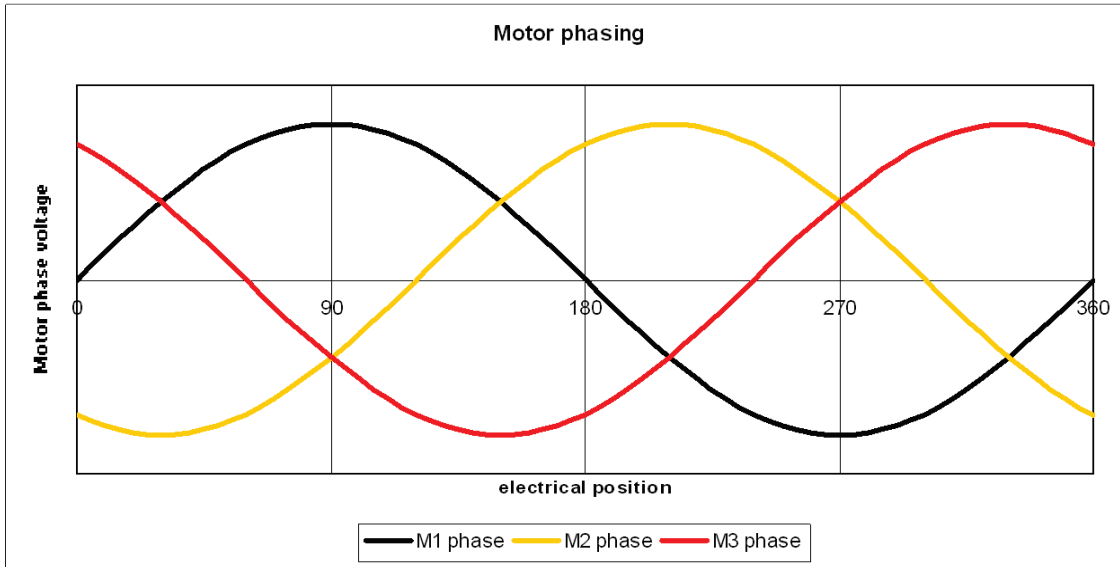

- ◆ The resolver must be adjusted in a way to give a position of 0 degrees when the M1 motor phase crosses the 0 Volt line in a rising variation. For example, a 6 pole motor associated with a 2 pole resolver will give the following curves:

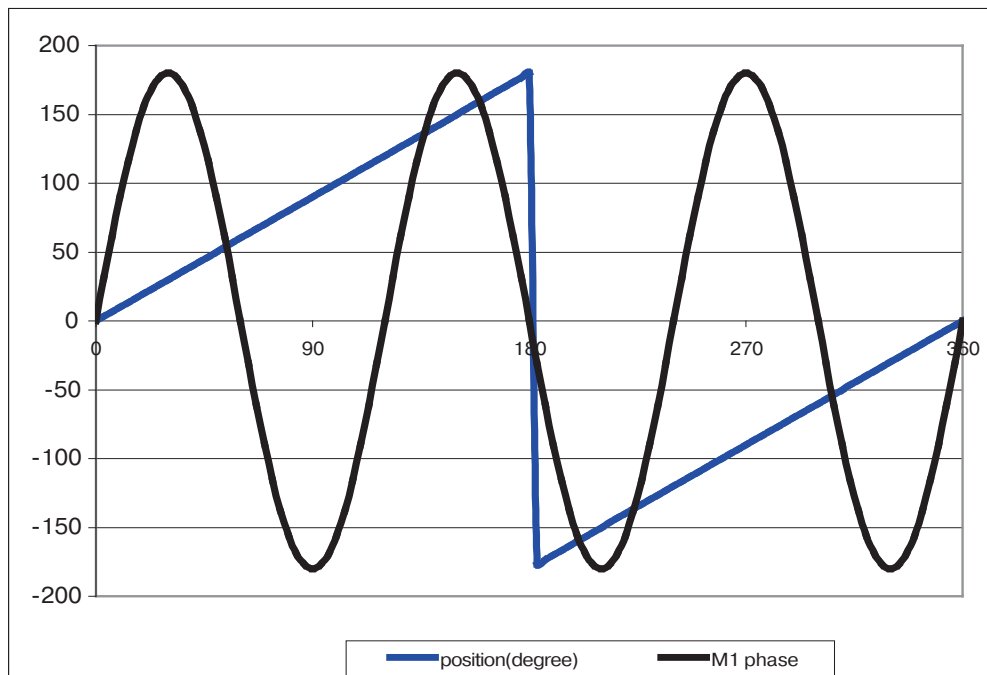

PROP 65 WARNING WARNING: This product can expose you to chemicals including **Lead and Lead Compounds** which are known to the State of California to cause cancer and birth defects or other reproductive harm. For more information go to www.P65Warnings.ca.gov

Safety Guide for Selecting and Using Hydraulic, Pneumatic Cylinders and Their Accessories

WARNING:  **FAILURE OF THE CYLINDER, ITS PARTS, ITS MOUNTING, ITS CONNECTIONS TO OTHER OBJECTS, OR ITS CONTROLS CAN RESULT IN:**

- Unanticipated or uncontrolled movement of the cylinder or objects connected to it.
- Falling of the cylinder or objects held up by it.
- Fluid escaping from the cylinder, potentially at high velocity.

THESE EVENTS COULD CAUSE DEATH OR PERSONAL INJURY BY, FOR EXAMPLE, PERSONS FALLING FROM HIGH LOCATIONS, BEING CRUSHED OR STRUCK BY HEAVY OR FAST MOVING OBJECTS, BEING PUSHED INTO DANGEROUS EQUIPMENT OR SITUATIONS, OR SLIPPING ON ESCAPED FLUID.

Before selecting or using Parker Hannifin Corporation (the Company) cylinders or related accessories, it is important that you read, understand and follow the following safety information. Training is advised before selecting and using the Company's products.

1.0 General Instructions

1.1 Scope – This safety guide provides instructions for selecting and using (including assembling, installing, and maintaining) cylinder products. This safety guide is a supplement to and is to be used with the specific Company publications for the specific cylinder products that are being considered for use.

1.2 Fail Safe – Cylinder products can and do fail without warning for many reasons. All systems and equipment should be designed in a fail-safe mode so that if the failure of a cylinder product occurs people and property won't be endangered.

1.3 Distribution – Provide a free copy of this safety guide to each person responsible for selecting or using cylinder products. Do not select or use the Company's cylinders without thoroughly reading and understanding this safety guide as well as the specific Company publications for the products considered or selected.

1.4 User Responsibility – Due to very wide variety of cylinder applications and cylinder operating conditions, the Company does not warrant that any particular cylinder is suitable for any specific application. This safety guide does not analyze all technical parameters that must be considered in selecting a product. The hydraulic and pneumatic cylinders outlined in this catalog are designed to the Company's design guidelines and do not necessarily meet the design guideline of other agencies such as American Bureau of Shipping, ASME Pressure Vessel Code etc. The user, through its own analysis and testing, is solely responsible for:

- Making the final selection of the cylinders and related accessories.
- Determining if the cylinders are required to meet specific design requirements as required by the Agency(s) or industry standards covering the design of the user's equipment.
- Assuring that the user's requirements are met, OSHA requirements are met, and safety guidelines from the applicable agencies such as but not limited to ANSI are followed and that the use presents no health or safety hazards.
- Providing all appropriate health and safety warnings on the equipment on which the cylinders are used.

1.5 Additional Questions – Call the appropriate Company technical service department if you have any questions or require any additional information. See the Company publication for the product being considered or used, or call 1-847-298-2400, or go to www.parker.com, for telephone numbers of the appropriate technical service department.

2.0 Cylinder and Accessories Selection

2.1 Seals – Part of the process of selecting a cylinder is the selection of seal compounds. Before making this selection, consult the "seal information page(s)" of the publication for the series of cylinders of interest.

The application of cylinders may allow fluids such as cutting fluids, wash down fluids etc. to come in contact with the external area of the cylinder. These fluids may attack the piston rod wiper and or the primary seal and must be taken into account when selecting and specifying seal compounds.

Dynamic seals will wear. The rate of wear will depend on many operating factors. Wear can be rapid if a cylinder is mis-aligned or if the cylinder has been improperly serviced. The user must take seal wear into consideration in the application of cylinders.

2.2 Piston Rods – Possible consequences of piston rod failure or separation of the piston rod from the piston include, but are not limited to are:

- Piston rod and or attached load thrown off at high speed.
- High velocity fluid discharge.
- Piston rod extending when pressure is applied in the piston retract mode.

Piston rods or machine members attached to the piston rod may move suddenly and without warning as a consequence of other conditions occurring to the machine such as, but not limited to:

- Unexpected detachment of the machine member from the piston rod.
- Failure of the pressurized fluid delivery system (hoses, fittings, valves, pumps, compressors) which maintain cylinder position.
- Catastrophic cylinder seal failure leading to sudden loss of pressurized fluid.
- Failure of the machine control system.

Follow the recommendations of the "Piston Rod Selection Chart and Data" in the publication for the series of cylinders of interest. The suggested piston rod diameter in these charts must be followed in order to avoid piston rod buckling.

Piston rods are not normally designed to absorb bending moments or loads which are perpendicular to the axis of piston rod motion. These additional loads can cause the piston rod to fail. If these types of additional loads are expected to be imposed on the piston rod, their magnitude should be made known to our engineering department.

The cylinder user should always make sure that the piston rod is securely attached to the machine member.

On occasion cylinders are ordered with double rods (a piston rod extended from both ends of the cylinder). In some cases a stop is threaded on to one of the piston rods and used as an external stroke adjuster. On occasions spacers are attached to the machine member connected to the piston rod and also used as a stroke adjuster. In both cases the stops will create a pinch point and the user should consider appropriate use of guards. If these

external stops are not perpendicular to the mating contact surface, or if debris is trapped between the contact surfaces, a bending moment will be placed on the piston rod, which can lead to piston rod failure. An external stop will also negate the effect of cushioning and will subject the piston rod to impact loading. Those two (2) conditions can cause piston rod failure. Internal stroke adjusters are available with and without cushions. The use of external stroke adjusters should be reviewed with our engineering department.

The piston rod to piston and the stud to piston rod threaded connections are secured with an anaerobic adhesive. The strength of the adhesive decreases with increasing temperature. Cylinders which can be exposed to temperatures above +250°F (+121°C) are to be ordered with a non studded piston rod and a pinned piston to rod joint.

2.3 Cushions – Cushions should be considered for cylinder applications when the piston velocity is expected to be over 4 inches/second.

Cylinder cushions are normally designed to absorb the energy of a linear applied load. A rotating mass has considerably more energy than the same mass moving in a linear mode. Cushioning for a rotating mass application should be reviewed by our engineering department.

2.4 Cylinder Mountings – Some cylinder mounting configurations may have certain limitations such as but not limited to minimum stroke for side or foot mounting cylinders or pressure de-ratings for certain mounts. Carefully review the catalog for these types of restrictions.

Always mount cylinders using the largest possible high tensile alloy steel socket head cap screws that can fit in the cylinder mounting holes and torque them to the manufacturer's recommendations for their size.

2.5 Port Fittings – Hydraulic cylinders applied with meter out or deceleration circuits are subject to intensified pressure at piston rod end.

The rod end pressure is approximately equal to:

$$\frac{\text{operating pressure} \times \text{effective cap end area}}{\text{effective rod end piston area}}$$

Contact your connector supplier for the pressure rating of individual connectors.

3.0 Cylinder and Accessories Installation and Mounting

3.1 Installation

3.1.1 – Cleanliness is an important consideration, and cylinders are shipped with the ports plugged to protect them from contaminants entering the ports. These plugs should not be removed until the piping is to be installed. Before making the connection to the cylinder ports, piping should be thoroughly cleaned to remove all chips or burrs which might have resulted from threading or flaring operations.

3.1.2 – Cylinders operating in an environment where air drying materials are present such as fast-drying chemicals, paint, or weld splatter, or other hazardous conditions such as excessive heat, should have shields installed to prevent damage to the piston rod and piston rod seals.

3.1.3 – Proper alignment of the cylinder piston rod and its mating component on the machine should be checked in both the extended and retracted positions. Improper alignment will result in excessive rod gland and/or cylinder bore wear. On fixed mounting cylinders attaching the piston rod while the rod is retracted will help in achieving proper alignment.

3.1.4 – Sometimes it may be necessary to rotate the piston rod in order to thread the piston rod into the machine member. This operation must always be done with zero pressure being applied to either side of the piston. Failure to follow this procedure may result in loosening the piston to rod-threaded connection. In some rare cases the turning of the piston rod may rotate a threaded piston rod gland and loosen it from the cylinder head. Confirm that this condition is not occurring. If it does, re-tighten the piston rod gland firmly against the cylinder head.

For double rod cylinders it is also important that when attaching or detaching the piston rod from the machine member that the torque be applied to the piston rod end of the cylinder that is directly attaching to the machine member with the opposite end unrestrained. If the design of the machine is such that only the rod end of the cylinder opposite to where the rod attaches to the machine member can be rotated, consult the factory for further instructions.

3.2 Mounting Recommendations

3.2.1 – Always mount cylinders using the largest possible high tensile alloy steel socket head screws that can fit in the cylinder mounting holes and torque them to the manufacturer's recommendations for their size.

3.2.2 – Side-Mounted Cylinders – In addition to the mounting bolts, cylinders of this type should be equipped with thrust keys or dowel pins located so as to resist the major load.

3.2.3 – Tie Rod Mounting – Cylinders with tie rod mountings are recommended for applications where mounting space is limited. The standard tie rod extension is shown as BB in dimension tables. Longer or shorter extensions can be supplied. Nuts used for this mounting style should be torqued to the same value as the tie rods for that bore size.

3.2.4 – Flange Mount Cylinders – The controlled diameter of the rod gland extension on head end flange mount cylinders can be used as a pilot to locate the cylinders in relation to the machine. After alignment has been obtained, the flanges may be drilled for pins or dowels to prevent shifting.

3.2.5 – Trunnion Mountings – Cylinders require lubricated bearing blocks with minimum bearing clearances. Bearing blocks should be carefully aligned and rigidly mounted so the trunnions will not be subjected to bending moments. The rod end should also be pivoted with the pivot pin in line and parallel to axis of the trunnion pins.

3.2.6 – Clevis Mountings – Cylinders should be pivoted at both ends with centerline of pins parallel to each other. After cylinder is mounted, be sure to check to assure that the cylinder is free to swing through its working arc without interference from other machine parts.

4.0 Cylinder and Accessories Maintenance, Troubleshooting and Replacement

4.1 Storage – At times cylinders are delivered before a customer is ready to install them and must be stored for a period of time. When storage is required the following procedures are recommended.

4.1.1 – Store the cylinders in an indoor area which has a dry, clean and noncorrosive atmosphere. Take care to protect the cylinder from both internal corrosion and external damage.

4.1.2 – Whenever possible cylinders should be stored in a vertical position (piston rod up). This will minimize corrosion due to possible condensation which could occur inside the cylinder. This will also minimize seal damage.

4.1.3 – Port protector plugs should be left in the cylinder until the time of installation.

4.1.4 – If a cylinder is stored full of hydraulic fluid, expansion of the fluid due to temperature changes must be considered. Installing a check valve with free flow out of the cylinder is one method.

4.1.5 – When cylinders are mounted on equipment that is stored outside for extended periods, exposed unpainted surfaces, e.g. piston rod, must be coated with a rust-inhibiting compound to prevent corrosion.

4.2 Cylinder Trouble Shooting

4.2.1 – External Leakage

4.2.1.1 – Rod seal leakage can generally be traced to worn or

damaged seals. Examine the piston rod for dents, gouges or score marks, and replace piston rod if surface is rough.

Rod seal leakage could also be traced to gland wear. If clearance is excessive, replace rod bushing and seal. Rod seal leakage can also be traced to seal deterioration. If seals are soft or gummy or brittle, check compatibility of seal material with lubricant used if air cylinder, or operating fluid if hydraulic cylinder. Replace with seal material, which is compatible with these fluids. If the seals are hard or have lost elasticity, it is usually due to exposure to temperatures in excess of 165°F. (+74°C). Shield the cylinder from the heat source to limit temperature to 350°F. (+177°C.) and replace with fluorocarbon seals.

4.2.1.2 – Cylinder body seal leak can generally be traced to loose tie rods. Torque the tie rods to manufacturer's recommendation for that bore size.

Excessive pressure can also result in cylinder body seal leak. Determine maximum pressure to rated limits. Replace seals and retorque tie rods as in paragraph above. Excessive pressure can also result in cylinder body seal leak. Determine if the pressure rating of the cylinder has been exceeded. If so, bring the operating pressure down to the rating of the cylinder and have the tie rods replaced.

Pinched or extruded cylinder body seal will also result in a leak. Replace cylinder body seal and retorque as in paragraph above.

Cylinder body seal leakage due to loss of radial squeeze which shows up in the form of flat spots or due to wear on the O.D. or I.D. – Either of these are symptoms of normal wear due to high cycle rate or length of service. Replace seals as per paragraph above.

4.2.2 – Internal Leakage

4.2.2.1 – Piston seal leak (by-pass) 1 to 3 cubic inches per minute leakage is considered normal for piston ring construction. Virtually no static leak with lipseal type seals on piston should be expected. Piston seal wear is a usual cause of piston seal leakage. Replace seals as required.

4.2.2.2 – With lipseal type piston seals excessive back pressure due to over-adjustment of speed control valves could be a direct cause of rapid seal wear. Contamination in a hydraulic system can result in a scored cylinder bore, resulting in rapid seal wear. In either case, replace piston seals as required.

4.2.2.3 – What appears to be piston seal leak, evidenced by the fact that the cylinder drifts, is not always traceable to the piston. To make sure, it is suggested that one side of the cylinder piston be pressurized and the fluid line at the opposite port be disconnected. Observe leakage. If none is evident, seek the cause of cylinder drift in other component parts in the circuit.

4.2.3 – Cylinder Fails to Move the Load

4.2.3.1 – Pneumatic or hydraulic pressure is too low. Check the pressure at the cylinder to make sure it is to circuit requirements.

4.2.3.2 – Piston Seal Leak – Operate the valve to cycle the cylinder and observe fluid flow at valve exhaust ports at end of cylinder stroke. Replace piston seals if flow is excessive.

4.2.3.3 – Cylinder is undersized for the load – Replace cylinder with one of a larger bore size.

4.3 Erratic or Chatter Operation

4.3.1 – Excessive friction at rod gland or piston bearing due to load misalignment – Correct cylinder-to-load alignment.

4.3.2 – Cylinder sized too close to load requirements – Reduce load or install larger cylinder.

4.3.3 – Erratic operation could be traced to the difference between static and kinetic friction. Install speed control valves to provide a back pressure to control the stroke.

4.4 Cylinder Modifications, Repairs, or Failed Component

Cylinders as shipped from the factory are not to be disassembled and or modified. If cylinders require modifications, these modifications must be done at company locations or by the Company's certified facilities. The Cylinder Division Engineering Department must be notified in the event of a mechanical fracture or permanent deformation of any cylinder component (excluding seals). This includes a broken piston rod, tie rod, mounting accessory or any other cylinder component. The notification should include all operation and application details. This information will be used to provide an engineered repair that will prevent recurrence of the failure.

It is allowed to disassemble cylinders for the purpose of replacing seals or seal assemblies. However, this work must be done by strictly following all the instructions provided with the seal kits.

The items described in this document and other documents and descriptions provided by Parker Hannifin Corporation, its subsidiaries and its authorized distributors ("Seller") are hereby offered for sale at prices to be established by Seller. This offer and its acceptance by any customer ("Buyer") shall be governed by all of the following Terms and Conditions. Buyer's order for any item described in its document, when communicated to Seller verbally, or in writing, shall constitute acceptance of this offer. All goods, services or work described will be referred to as "Products".

1. Terms. All sales of Products by Seller are expressly conditioned upon, and will be governed by the acceptance of these Terms. These Terms are incorporated into any Quote provided by Seller to Buyer. Buyer's order for any Products whether communicated to Seller verbally, in writing, by electronic data interface or other electronic commerce, shall constitute acceptance of these Terms. Seller objects to any contrary or additional terms or conditions of Buyer. Reference in Seller's order acknowledgement to Buyer's purchase order or purchase order number shall in no way constitute an acceptance of any of Buyer's terms or conditions of purchase. No modification to these Terms will be binding on Seller unless agreed to in writing and signed by an authorized representative of Seller.

2. Price; Payment. The Products set forth in the Quote are offered for sale at the prices indicated in the Quote. Unless otherwise specifically stated in the Quote, prices are valid for thirty (30) days and do not include any sales, use, or other taxes or duties. Seller reserves the right to modify prices at any time to adjust for any raw material price fluctuations. Unless otherwise specified by Seller, all prices are F.C.A. Seller's facility (INCOTERMS 2020). All sales are contingent upon credit approval and full payment for all purchases is due thirty (30) days from the date of invoice (or such date as may be specified in the Quote). Unpaid invoices beyond the specified payment date incur interest at the rate of 1.5% per month or the maximum allowable rate under applicable law.

3. Shipment; Delivery; Title and Risk of Loss. All delivery dates are approximate, and Seller is not responsible for damages resulting from any delay. Regardless of the manner of shipment, delivery occurs and title and risk of loss or damage pass to Buyer, upon placement of the Products with the carrier at Seller's facility. Unless otherwise agreed prior to shipment and for domestic delivery locations only, Seller will select and arrange, at Buyer's sole expense, the carrier and means of delivery. When Seller selects and arranges the carrier and means of delivery, freight and insurance costs for shipment to the designated delivery location will be prepaid by Seller and added as a separate line item to the invoice. Buyer shall be responsible for any additional shipping charges incurred by Seller due to Buyer's acts or omissions. Buyer shall not return or repack any Products without the prior written authorization from Seller, and any return shall be at the sole cost and expense of Buyer.

4. Warranty. The warranty for the Products is as follows: (i) Goods are warranted against defects in material or workmanship for a period of eighteen (18) months from the date of delivery or 2,000 hours of use, whichever occurs first; (ii) Services shall be performed in accordance with generally accepted practices and using the degree of care and skill that is ordinarily exercised and customary in the field to which the Services pertain and are warranted for a period of six (6) months from the date of completion of the Services; and (iii) Software is only warranted to perform in accordance with applicable specifications provided by Seller to Buyer for ninety (90) days from the date of delivery or, when downloaded by a Buyer or end-user, from the date of the initial download. All prices are based upon the exclusive limited warranty stated above, and upon the following disclaimer: EXEMPTION CLAUSE; DISCLAIMER OF WARRANTY, CONDITIONS, REPRESENTATIONS: THIS WARRANTY IS THE SOLE AND ENTIRE WARRANTY, CONDITION, AND REPRESENTATION, PERTAINING TO PRODUCTS. SELLER DISCLAIMS ALL OTHER WARRANTIES, CONDITIONS, AND REPRESENTATIONS, WHETHER STATUTORY, EXPRESS OR IMPLIED, INCLUDING BUT NOT LIMITED TO THOSE RELATING TO DESIGN, NONINFRINGEMENT, MERCHANTABILITY, AND FITNESS FOR A PARTICULAR PURPOSE. SELLER DOES NOT WARRANT THAT THE SOFTWARE IS ERROR-FREE OR FAULT-TOLERANT, OR THAT BUYER'S USE THEREOF WILL BE SECURE OR UNINTERRUPTED. UNLESS OTHERWISE AUTHORIZED IN WRITING BY SELLER, THE SOFTWARE SHALL NOT BE USED IN CONNECTION WITH HAZARDOUS OR HIGH RISK ACTIVITIES OR ENVIRONMENTS. EXCEPT AS EXPRESSLY STATED HEREIN, ALL PRODUCTS ARE PROVIDED "AS IS".

5. Claims; Commencement of Actions. Buyer shall promptly inspect all Products upon receipt. No claims for shortages will be allowed unless reported to Seller within ten (10) days of delivery. Buyer shall notify Seller of any alleged breach of warranty within thirty (30) days after the date the non-conformance is or should have been discovered by Buyer. Any claim or action against Seller based upon breach of contract or any other theory, including tort, negligence, or otherwise must be commenced within twelve (12) months from the date of the alleged breach or other alleged event, without regard to the date of discovery.

6. LIMITATION OF LIABILITY. IN THE EVENT OF A BREACH OF WARRANTY, SELLER WILL, AT ITS OPTION, REPAIR OR REPLACE THE NON-CONFORMING PRODUCT, RE-PERFORM THE SERVICES, OR REFUND THE PURCHASE PRICE PAID WITHIN A REASONABLE PERIOD OF TIME. IN NO EVENT IS SELLER LIABLE FOR ANY SPECIAL, INDIRECT, INCIDENTAL OR CONSEQUENTIAL DAMAGES INCLUDING ANY LOSS OF REVENUE OR PROFITS, WHETHER BASED IN CONTRACT, TORT OR OTHER LEGAL THEORY. IN NO EVENT SHALL SELLER'S LIABILITY UNDER ANY CLAIM MADE BY BUYER EXCEED THE PURCHASE PRICE PAID FOR THE PRODUCTS.

7. Confidential Information. Buyer acknowledges and agrees that any technical, commercial, or other confidential information of Seller, including, without limitation, pricing, technical drawings or prints and/or part lists, which has been or will be disclosed, delivered or made available, whether directly or indirectly, to Buyer ("Confidential Information"), has been and will be received in confidence and will remain the property of Seller. Buyer further agrees that it will not use Seller's Confidential Information for any purpose other than for the benefit of Seller.

8. Loss to Buyer's Property. Any tools, patterns, materials, equipment or information furnished by Buyer or which are or become Buyer's property ("Buyer's Property"), will be considered obsolete and may be destroyed by Seller after two (2) consecutive years have elapsed without Buyer ordering the Products manufactured using Buyer's Property. Furthermore, Seller shall not be responsible for any loss or damage to Buyer's Property while it is in Seller's possession or control.

9. Special Tooling. "Special Tooling" includes but is not limited to tools, jigs, fixtures and associated manufacturing equipment acquired or necessary to manufacture Goods. Seller may impose a tooling charge for any Special Tooling. Such Special Tooling shall be and remain Seller's property notwithstanding payment of any charges by Buyer. In no event will Buyer acquire any interest in the Special Tooling, even if such Special Tooling has been specially converted or adapted for manufacture of Goods for Buyer and notwithstanding any charges paid by Buyer. Unless otherwise agreed, Seller has the right to alter, discard or otherwise dispose of any Special Tooling or other property owned by Seller in its sole discretion at any time.

10. Security Interest. To secure payment of all sums due from Buyer, Seller retains a security interest in all Products delivered to Buyer and, Buyer's acceptance of these Terms is deemed to be a Security Agreement under the Uniform Commercial Code. Buyer authorizes Seller as its attorney to execute and file on Buyer's behalf all documents Seller deems necessary to perfect Seller's security interest.

11. User Responsibility. Buyer, through its own analysis and testing, is solely responsible for making the final selection of the Products and assuring that all performance, endurance, maintenance, safety and warning requirements of the application of the Products are met. Buyer must analyze all aspects of the application and follow applicable industry standards, specifications, and any technical information provided with the Quote or the Products, such as Seller's instructions, guides and specifications. If Seller provides options of or for Products based upon data or specifications provided by Buyer, Buyer is responsible for determining that such data and specifications are suitable and sufficient for all applications and reasonably foreseeable uses of the Products. In the event Buyer is not the end-user of the Products, Buyer will ensure such end-user complies with this paragraph.

12. Use of Products; Indemnity by Buyer. Buyer shall comply with all instructions, guides and specifications provided by Seller with the Quote or the Products. Unauthorized Uses. If Buyer uses or resells the Products in any

way prohibited by Seller's instructions, guides or specifications, or Buyer otherwise fails to comply with Seller's instructions, guides and specifications, Buyer acknowledges that any such use, resale, or non-compliance is at Buyer's sole risk. Further, Buyer shall indemnify, defend, and hold Seller harmless from any losses, claims, liabilities, damages, lawsuits, judgments and costs (including attorney fees and defense costs), whether for personal injury, property damage, intellectual property infringement or any other claim, arising out of or in connection with: (a) improper selection, design, specification, application, or any misuse of Products; (b) any act or omission, negligent or otherwise, of Buyer; (c) Seller's use of patterns, tools, equipment, plans, drawings, designs, specifications or other information or things furnished by Buyer; (d) damage to the Products from an external cause, repair or attempted repair by anyone other than Seller, failure to follow instructions, guides and specifications provided by Seller, use with goods not provided by Seller, or opening, modifying, deconstructing, tampering with or repackaging the Products; or (e) Buyer's failure to comply with these Terms. Seller shall not indemnify Buyer under any circumstance except as otherwise provided in these Terms.

13. Cancellations and Changes. Buyer may not cancel or modify, including but not limited to movement of delivery dates for the Products, any order for any reason except with Seller's written consent and upon terms that will indemnify, defend and hold Seller harmless against all direct, incidental and consequential loss or damage and any additional expense. Seller, at any time, may change features, specifications, designs and availability of Products.

14. Limitation on Assignment. Buyer may not assign its rights or obligations without the prior written consent of Seller.

15. Force Majeure. Seller is not liable for delay or failure to perform any of its obligations by reason of events or circumstances beyond its reasonable control. Such circumstances include without limitation: accidents, labor disputes or stoppages, government acts or orders, acts of nature, pandemics, epidemics, other widespread illness, or public health emergency, delays or failures in delivery from carriers or suppliers, shortages of materials, war (whether declared or not) or the serious threat of same, riots, rebellions, acts of terrorism, fire or any reason whether similar to the foregoing or otherwise. Seller will resume performance as soon as practicable after the event of force majeure has been removed. All delivery dates affected by force majeure shall be tolled for the duration of such force majeure and rescheduled for mutually agreed dates as soon as practicable after the force majeure condition ceases to exist. Force majeure shall not include financial distress, insolvency, bankruptcy, or other similar conditions affecting one of the parties, affiliates and/or sub-contractors.

16. Waiver and Severability. Failure to enforce any provision of these Terms will not invalidate that provision; nor will any such failure prejudice either party's right to enforce that provision in the future. Invalidation of any provision of these Terms shall not invalidate any other provision herein and, the remaining provisions will remain in full force and effect.

17. Termination. Seller may terminate any agreement governed by or arising from these Terms for any reason and at any time by giving Buyer thirty (30) days prior written notice. Seller may immediately terminate, in writing, if Buyer: (a) breaches any provision of these Terms, (b) becomes or is deemed insolvent, (c) appoints or has appointed a trustee, receiver or custodian for all or any part of Buyer's property, (d) files a petition for relief in bankruptcy on its own behalf, or one is filed against Buyer by a third party, (e) makes an assignment for the benefit of creditors; or (f) dissolves its business or liquidates all or a majority of its assets.

18. Ownership of Software. Seller retains ownership of all Software supplied to Buyer hereunder. In no event shall Buyer obtain any greater right in and to the Software than a right in the nature of a license limited to the use thereof and subject to compliance with any other terms provided with the Software.

19. Indemnity for Infringement of Intellectual Property Rights. Seller is not liable for infringement of any patents, trademarks, copyrights, trade dress, trade secrets or similar rights ("Intellectual Property Rights") except as provided in this Section. Seller will defend at its expense and will pay the cost of any settlement or damages awarded in an action brought against Buyer based on a third party claim that one or more of the Products sold hereunder infringes the Intellectual Property Rights of a third party in the country of delivery of the Products by Seller to Buyer. Seller's obligation to defend and indemnify Buyer is contingent on Buyer notifying Seller within ten (10) days after Buyer becomes aware of any such claim, and Seller having sole control over the defense of the claim including all negotiations for settlement or compromise. If one or more Products sold hereunder is subject to such a claim, Seller may, at its sole expense and option, procure for Buyer the right to continue using the Products, replace or modify the Products so as to render them non-infringing, or offer to accept return of the Products and refund the purchase price less a reasonable allowance for depreciation. Seller has no obligation or liability for any claim of infringement: (i) arising from information provided by Buyer; or (ii) directed to any Products provided hereunder for which the designs are specified in whole or part by Buyer; or (iii) resulting from the modification, combination or use in a system of any Products provided hereunder. The foregoing provisions of this Section constitute Seller's sole and exclusive liability and Buyer's sole and exclusive remedy for claims of infringement of Intellectual Property Rights.

20. Governing Law. These Terms and the sale and delivery of all Products are deemed to have taken place in, and shall be governed and construed in accordance with the laws of the State of Ohio, as applicable to contracts executed and wholly performed therein and without regard to conflicts of laws principles. Buyer irrevocably agrees and consents to the exclusive jurisdiction and venue of the courts of Cuyahoga County, Ohio with respect to any dispute, controversy or claim arising out of or relating to the sale and delivery of the Products.

21. Entire Agreement. These Terms, along with the terms set forth in the main body of any Quote, forms the entire agreement between the Buyer and Seller and constitutes the final, complete and exclusive expression of the terms of sale and purchase. In the event of a conflict between any term set forth in the main body of a Quote and these Terms, the terms set forth in the main body of the Quote shall prevail. All prior or contemporaneous written or oral agreements or negotiations with respect to the subject matter shall have no effect. These Terms may not be modified unless in writing and signed by an authorized representative of Seller.

22. Compliance with Laws. Buyer agrees to comply with all applicable laws, regulations, and industry and professional standards, including those of the United States of America, and the country or countries in which Buyer may operate, including without limitation the U.S. Foreign Corrupt Practices Act ("FCPA"), the U.S. Anti-Kickback Act ("Anti-Kickback Act"), U.S. and E.U. export control and sanctions laws ("Export Laws"), the U.S. Food Drug and Cosmetic Act ("FDCA"), and the rules and regulations promulgated by the U.S. Food and Drug Administration ("FDA"), each as currently amended. Buyer agrees to indemnify, defend, and hold harmless Seller from the consequences of any violation of such laws, regulations and standards by Buyer, its employees or agents. Buyer acknowledges that it is familiar with all applicable provisions of the FCPA, the Anti-Kickback Act, Export Laws, the FDCA and the FDA and certifies that Buyer will adhere to the requirements thereof and not take any action that would make Seller violate such requirements. Buyer represents and agrees that Buyer will not make any payment or give anything of value, directly or indirectly, to any governmental official, foreign political party or official thereof, candidate for foreign political office, or commercial entity or person, for any improper purpose, including the purpose of influencing such person to purchase Products or otherwise benefit the business of Seller. Buyer further represents and agrees that it will not receive, use, service, transfer or ship any Products from Seller in a manner or for a purpose that violates Export Laws or would cause Seller to be in violation of Export Laws. Buyer agrees to promptly and reliably provide Seller all requested information or documents, including end-user statements and other written assurances, concerning Buyer's ongoing compliance with Export Laws. 8/20



Parker's Motion & Control Technologies

At Parker, we're guided by a relentless drive to help our customers become more productive and achieve higher levels of profitability by engineering the best systems for their requirements. It means looking at customer applications from many angles to find new ways to create value. Whatever the motion and control technology need, Parker has the experience, breadth of product and global reach to consistently deliver. No company knows more about motion and control technology than Parker. For further info call 1 800 C-Parker (1 800 272 7537)



Aerospace

Key Markets

- Aftermarket services
- Commercial transports
- Engines
- General & business aviation
- Helicopters
- Launch vehicles
- Military aircraft
- Missiles
- Power generation
- Regional transports
- Unmanned aerial vehicles

Key Products

- Control systems & actuation products
- Engine systems & components
- Fluid conveyance systems & components
- Fluid metering, delivery & atomization devices
- Fuel systems & components
- Fuel tank inerting systems
- Hydraulic systems & components
- Thermal management
- Wheels & brakes



Climate Control

Key Markets

- Agriculture
- Air conditioning
- Construction Machinery
- Food & beverage
- Industrial machinery
- Life sciences
- Oil & gas
- Precision cooling
- Process
- Refrigeration
- Transportation

Key Products

- Accumulators
- Advanced actuators
- CO₂ controls
- Electronic controllers
- Filter driers
- Hand shut-off valves
- Heat exchangers
- Hose & fittings
- Pressure regulating valves
- Refrigerant distributors
- Safety relief valves
- Smart pumps
- Solenoid valves
- Thermostatic expansion valves



Electromechanical

Key Markets

- Aerospace
- Factory automation
- Life science & medical
- Machine tools
- Packaging machinery
- Paper machinery
- Plastics machinery & converting
- Primary metals
- Semiconductor & electronics
- Textile
- Wire & cable

Key Products

- AC/DC drives & systems
- Electric actuators, gantry robots & slides
- Electrohydraulic actuation systems
- Electromechanical actuation systems
- Human machine interface
- Linear motors
- Stepper motors, servo motors, drives & controls
- Structural extrusions



Filtration

Key Markets

- Aerospace
- Food & beverage
- Industrial plant & equipment
- Life sciences
- Marine
- Mobile equipment
- Oil & gas
- Power generation & renewable energy
- Process
- Transportation
- Water Purification

Key Products

- Analytical gas generators
- Compressed air filters & dryers
- Engine air, coolant, fuel & oil filtration systems
- Fluid condition monitoring systems
- Hydraulic & lubrication filters
- Hydrogen, nitrogen & zero air generators
- Instrumentation filters
- Membrane & fiber filters
- Microfiltration
- Sterile air filtration
- Water desalination & purification filters & systems



Fluid & Gas Handling

Key Markets

- Aerial lift
- Agriculture
- Bulk chemical handling
- Construction machinery
- Food & beverage
- Fuel & gas delivery
- Industrial machinery
- Life sciences
- Marine
- Mining
- Mobile
- Oil & gas
- Renewable energy
- Transportation

Key Products

- Check valves
- Connectors for low pressure fluid conveyance
- Deep sea umbilicals
- Diagnostic equipment
- Hose couplings
- Industrial hose
- Mooring systems & power cables
- PTFE hose & tubing
- Quick couplings
- Rubber & thermoplastic hose
- Tube fittings & adapters
- Tubing & plastic fittings



Hydraulics

Key Markets

- Aerial lift
- Agriculture
- Alternative energy
- Construction machinery
- Forestry
- Industrial machinery
- Machine tools
- Marine
- Material handling
- Mining
- Oil & gas
- Power generation
- Refuse vehicles
- Renewable energy
- Truck hydraulics
- Turf equipment

Key Products

- Accumulators
- Cartridge valves
- Electrohydraulic actuators
- Human machine interfaces
- Hybrid drives
- Hydraulic cylinders
- Hydraulic motors & pumps
- Hydraulic systems
- Hydraulic valves & controls
- Hydrostatic steering
- Integrated hydraulic circuits
- Power take-offs
- Power units
- Rotary actuators
- Sensors



Pneumatics

Key Markets

- Aerospace
- Conveyor & material handling
- Factory automation
- Life science & medical
- Machine tools
- Packaging machinery
- Transportation & automotive

Key Products

- Air preparation
- Brass fittings & valves
- Manifolds
- Pneumatic accessories
- Pneumatic actuators & grippers
- Pneumatic valves & controls
- Quick disconnects
- Rotary actuators
- Rubber & thermoplastic hose & couplings
- Structural extrusions
- Thermoplastic tubing & fittings
- Vacuum generators, cups & sensors



Process Control

Key Markets

- Alternative fuels
- Biopharmaceuticals
- Chemical & refining
- Food & beverage
- Marine & shipbuilding
- Medical & dental
- Microelectronics
- Nuclear Power
- Offshore oil exploration
- Oil & gas
- Pharmaceuticals
- Power generation
- Pulp & paper
- Steel
- Water/wastewater

Key Products

- Analytical Instruments
- Analytical sample conditioning products & systems
- Chemical injection fittings & valves
- Fluoropolymer chemical delivery fittings, valves & pumps
- High purity gas delivery fittings, valves, regulators & digital flow controllers
- Industrial mass flow meters/ controllers
- Permanent no-weld tube fittings
- Precision industrial regulators & flow controllers
- Process control double block & bleeds
- Process control fittings, valves, regulators & manifold valves



Sealing & Shielding

Key Markets

- Aerospace
- Chemical processing
- Consumer
- Fluid power
- General industrial
- Information technology
- Life sciences
- Microelectronics
- Military
- Oil & gas
- Power generation
- Renewable energy
- Telecommunications
- Transportation

Key Products

- Dynamic seals
- Elastomeric o-rings
- Electro-medical instrument design & assembly
- EMI shielding
- Extruded & precision-cut, fabricated elastomeric seals
- High temperature metal seals
- Homogeneous & inserted elastomeric shapes
- Medical device fabrication & assembly
- Metal & plastic retained composite seals
- Shielded optical windows
- Silicone tubing & extrusions
- Thermal management
- Vibration dampening

ENGINEERING YOUR SUCCESS.



Parker Hannifin Corporation
Cylinder Division
500 South Wolf Road
Des Plaines, IL 60016
phone (847) 298-2400
fax (800) 892-1008
www.parker.com/cylinder