

# Hybrid Actuation System Cylinders

Installation Manual



ENGINEERING YOUR SUCCESS.

# Table of Contents

Introduction.....	3
Product Description .....	5
Product Compliance .....	6
Product Labeling.....	7
HAS 500 Model Code .....	8
HAS-ST Model Code .....	10
Base Cylinder Model Codes.....	12
HAS Surface Preparation .....	18
HAS Component Identification .....	19
Operating Temperature .....	21
Fluid Selections .....	22
Elevation .....	27
Valves and Adjustments.....	30
Low Oil Level Sensor .....	38
Motors .....	39
Pressure Transducers.....	44
Maintenance .....	45
Oil Sampling .....	46
Pumps .....	47
Fluid Replacement.....	48
Cylinder Fluid Replacement .....	49
Fluid Filling .....	53
Detached HAS Units.....	59
Flushing Inner Connection lines .....	60
Application Guide Lines .....	61
Placement .....	67
Cylinder Safety Guide.....	68
Offer of Sale .....	70

# Introduction

Parker Hannifin's Hybrid Actuators Series HAS are self-contained, all in one hydraulic systems. The assembly may be under pressure and have live electrical power and should only be service by individuals familiar with Hydraulic and Electrical Equipment.

## Warnings

Sections marked with a symbol in the left margin, must be read and understood by everyone using the system, carrying out service work, or making changes to hardware and software.

The different symbols used in this manual are defined below



### WARNING

Sections labeled WARNING with a caution symbol in the left margin, indicate that a hazardous situation exists. We use warnings, marked with the warning symbol, in two ways

- As a strong recommendation about work practices when using the product in the machine (e.g. routines when updating an application). This use is common to the term 'hazardous situation', that a person is exposed to a hazard.
- As a way of pointing out important information for the machine designer that in some way relates to safety. This includes the design of the physical machine, and also the application program being developed for the control system.

Not all document sections that contain information about safety are marked with a warning symbol. Failure to comply with the recommendations can cause unintentional, and unexpected behavior of the control.



### NOTICE

Sections labeled NOTICE with a notice symbol in the left margin, indicate there is important information about the product. Ignoring this could result in less than optimal performance, or damage to the product.

Contact the manufacturer if there is anything you are not sure about or if you have any questions regarding the product and its handling or maintenance.

The term "manufacturer" refers to Parker Hannifin Corporation.



**PROP 65 WARNING**

**WARNING:** This product can expose you to chemicals including Lead and Lead Compounds which are known to the State of California to cause cancer and birth defects or other reproductive harm. For more information go to [www.P65Warnings.ca.gov](http://www.P65Warnings.ca.gov)

# Introduction

Work on the hydraulics and control electronics may only be carried out by trained personnel who are well-acquainted with the control system, the machine and its safety regulations.



## WARNING

Make sure that you have sufficient knowledge before designing, modifying or servicing the hydraulics and control system. Read the relevant sections of this document before conducting any work on the control system.



## WARNING

This product is not field repairable.



## NOTICE

Any welding work on the machine should be done before the installation of the Hybrid Actuator System or electrical equipment. If welding has to be done afterwards, the electrical connections on the system must be disconnected from other equipment. The negative/common wire must always be disconnected before disconnecting the positive cable. The ground wire of the welder shall be positioned as close as possible to the place of the welding. The cables on the welding unit shall never be placed near the electrical wires of the control system. Welding part to or on the HAS units is prohibited.

## Read This

Design of control system



## WARNING

Risk of injury may be introduced by design of control system!

This product is designed to provide high force motion. The control application must be designed using basic safety principles so that unintentional movement is avoided.

Start-up, maintenance, and diagnostics

For all personnel carrying out installation, commissioning, maintenance or troubleshooting.



## WARNING

Work on the hydraulics control electronics may only be carried out by trained personnel who are well-acquainted with the control system, the machine and its safety regulations.



### PROP 65 WARNING

**WARNING:** This product can expose you to chemicals including Lead and Lead Compounds which are known to the State of California to cause cancer and birth defects or other reproductive harm. For more information go to [www.P65Warnings.ca.gov](http://www.P65Warnings.ca.gov)

# Product Description

## Hybrid Actuation System

Hybrid Actuation System (HAS) are self-contained all in one plug and play actuators. Hydraulic fluid is transmitted into the base cylinder hydrostatically. Integral pump and reversing motor are housed in the upper manifold assembly. Designed for either equal area or unequal area cylinders, make up oil is obtained by connecting the low pressure leg directly to the system reservoir. With this concept, in the advent of overrunning load, a load control or counter-balance valve is required. To hold the load in place, a pilot operated check valve may be used. Many configurable load control options are available and housed in the lower manifold. Custom hydraulic circuits are also available, please consult factory for options.

The system is supplied flushed clean to ISO 16/14/11 cleanliness standard, then vacuum filled with hydraulic fluid. See fluid section for more details.



When commanded Hybrid Actuation System cylinders (HAS) create motion and high thrust forces. All lockout/Tag out procedures must be followed. HAS actuators may be locked in place and contain pressurized fluid. HAS actuators are designed to be replaced as an assembly and serviced by authorized personnel. They should be returned to the factory for service.

**⚠ PROP 65 WARNING** **WARNING:** This product can expose you to chemicals including Lead and Lead Compounds which are known to the State of California to cause cancer and birth defects or other reproductive harm. For more information go to [www.P65Warnings.ca.gov](http://www.P65Warnings.ca.gov)

# Product Compliance

## A Series Motors



### EC DECLARATION OF CONFORMITY

Name of Authorised Representative: Parker Hannifin Corporation  
Electromechanical & Drives, NA

Address of Authorised Representative: 5500 Business Park Drive  
Rohnert Park, CA 94928 USA  
tel (800) 358-9068 fax (707) 584-8015

Equipment: MaxPlusPlus (MPP) Series Rotary Motor Family  
MaxPlusPlus (MPJ) Medium Inertia Rotary Motor Family

Description of Equipment: Low Inertia, High Power Rotary Servo Motors  
See the User Guide for a full description of function

Year in which CE mark affixed: 2006

The above equipment conforms with the protection requirements of the following Council Directives on the approximation of the laws of the Member States relating to Electromagnetic Compatibility when installed, operated and maintained as intended:

73/23/EEC Low Voltage Directive (as amended by Directive 93/68/EEC)  
2011/65/EU Restriction of Hazardous Substances Directive

The installation requirements are detailed in the User Guide supplied with the equipment. The equipment is sold only to competent system builders.

Compliance is demonstrated by the application of the following standards:

EN 60034-1 Rotating Electrical Machines Part 1, Rating and Performance  
June 2004

BS EN 60950 Safety of Information Technology Equipment  
(2001)

Signed: \_\_\_\_\_

Date: 10/22/2018



Name: Stuart E. Goodnick  
Position: Division Engineering Manager, Parker Hannifin EMN, NA

88-033493-01

**⚠ PROP 65 WARNING** **WARNING:** This product can expose you to chemicals including Lead and Lead Compounds which are known to the State of California to cause cancer and birth defects or other reproductive harm. For more information go to [www.P65Warnings.ca.gov](http://www.P65Warnings.ca.gov)



# Product Identification

## HAS Power Pack Label

**HAS Power Pack Label**

The diagram shows a rectangular label with the following information and callouts:

- Parker** logo
- Hybrid System Date MFG: 11/29/22
- Series HAS Made in the USA
- S/O: 172621 -0001 (Sales Order No—Line Item)
- P/N: 1HHS2000000050 (HAS Part Number)
- Model: G031010D09A1RCAEA1N0HE (HAS Model Code)
- Relief Pressure Setting x 100 (PSI): 10 Push, 10 Pull (HAS Pressure Relief Setting)
- PTS ID: 1ZPDS20R (PTS ID (Serial No))
- Barcode with URL: parker.com/PTS

**Base Cylinder Label**

The diagram shows a rounded rectangular label with the following information and callouts:

- Parker Cylinders** logo
- Cylinder and Accumulator Division, Des Plaines, IL 60016
- PT. NO. 1HHS2000000050 (Cylinder Part Number)
- 2.50JJHS2HNNH-1S24A20.000 (Cylinder Model Code)
- SER. NO. K1244510001B (Serial Number)
- PRESSURE RATING, PSI 3000 (Cylinder Pressure Rating)

### Orders Bult After 2023

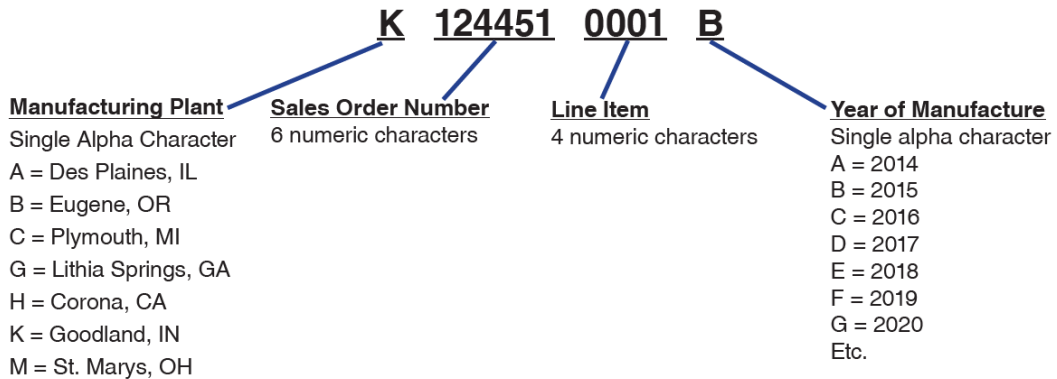

**⚠ PROP 65 WARNING** **WARNING:** This product can expose you to chemicals including Lead and Lead Compounds which are known to the State of California to cause cancer and birth defects or other reproductive harm. For more information go to [www.P65Warnings.ca.gov](http://www.P65Warnings.ca.gov)



**Series HAS Code**

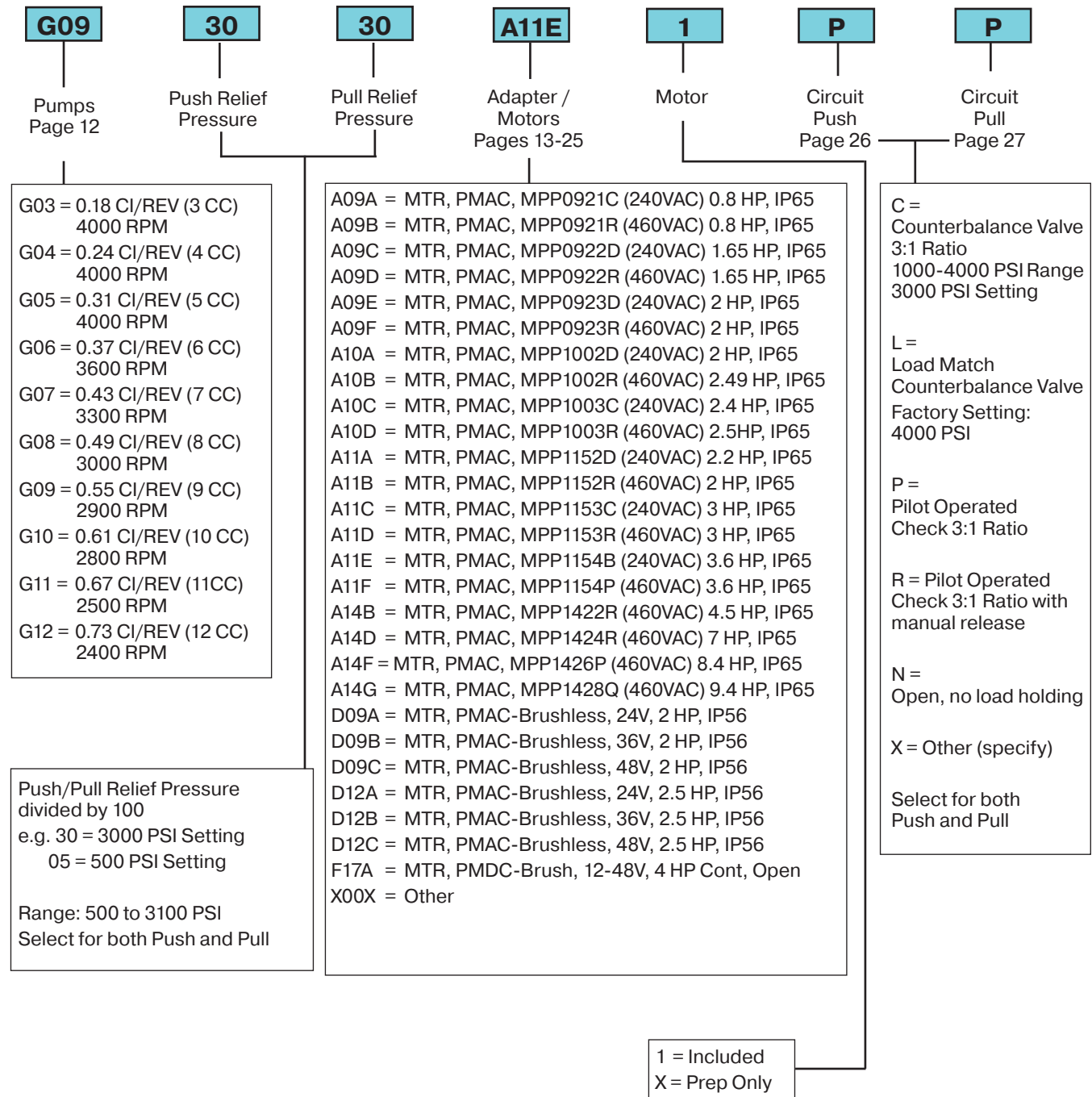

Model code selection for the HAS Power Pack for cylinder type and model selection, see page 12 for HS2 and 16 for HSR.

**PROP 65 WARNING** **WARNING:** This product can expose you to chemicals including Lead and Lead Compounds which are known to the State of California to cause cancer and birth defects or other reproductive harm. For more information go to [www.P65Warnings.ca.gov](http://www.P65Warnings.ca.gov)



**Series HAS Code**

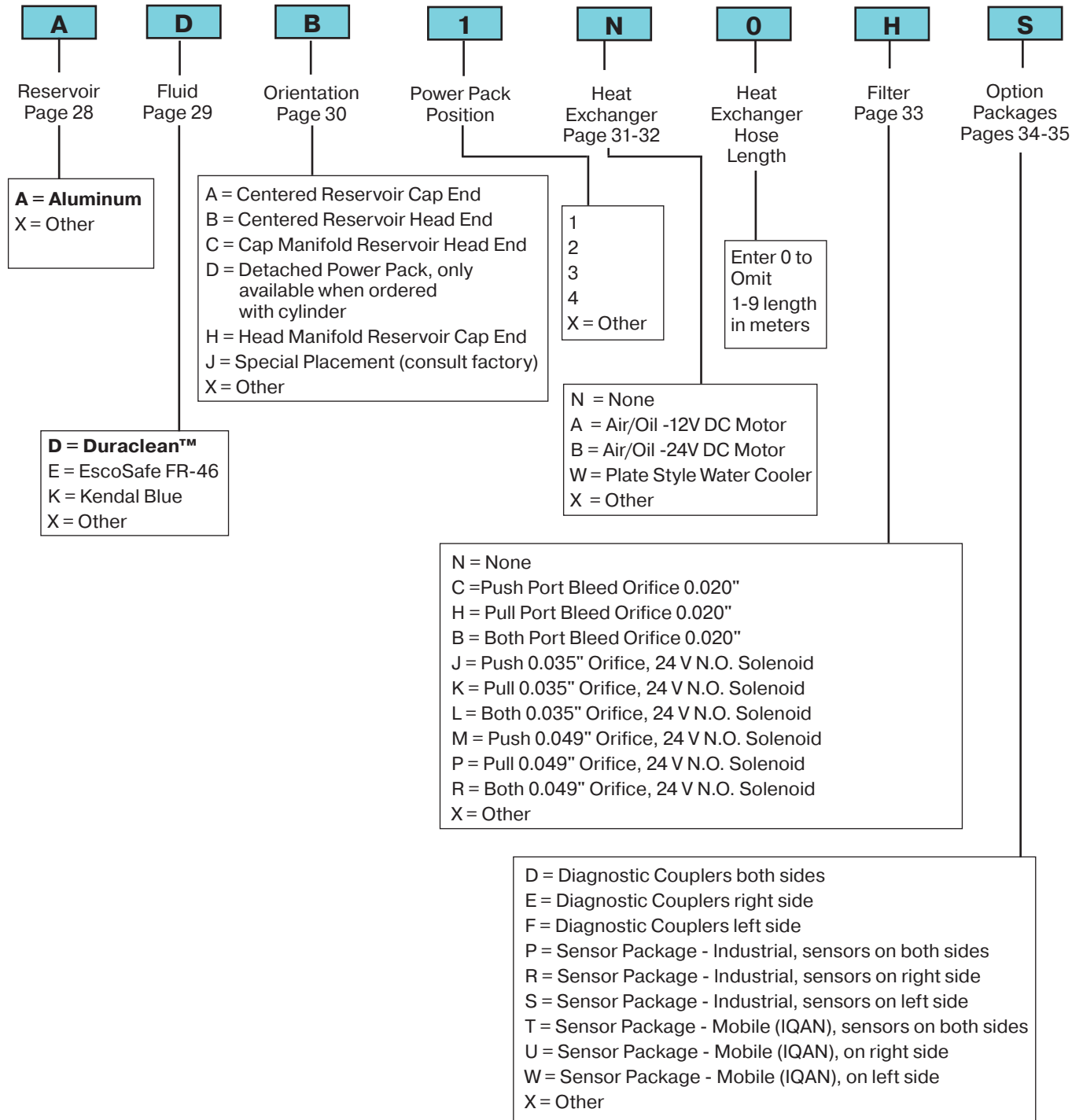

**⚠ PROP 65 WARNING** **WARNING:** This product can expose you to chemicals including Lead and Lead Compounds which are known to the State of California to cause cancer and birth defects or other reproductive harm. For more information go to [www.P65Warnings.ca.gov](http://www.P65Warnings.ca.gov)



**Series HAS Code**

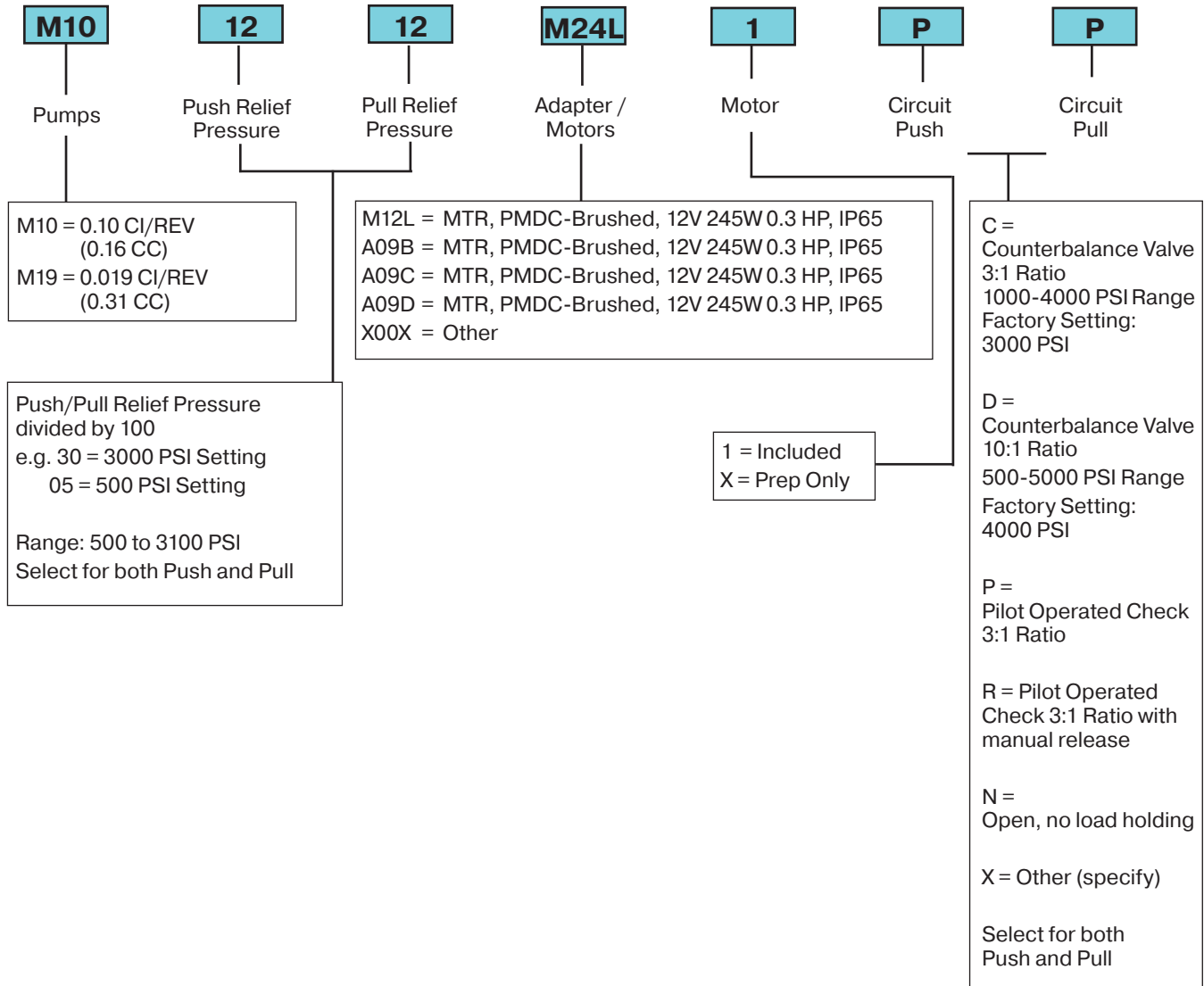

Model code selection for the HAS Power Pack for cylinder type and model selection, see pages 12 for HS2 and 16 for HSR.

**⚠ PROP 65 WARNING** **WARNING:** This product can expose you to chemicals including Lead and Lead Compounds which are known to the State of California to cause cancer and birth defects or other reproductive harm. For more information go to [www.P65Warnings.ca.gov](http://www.P65Warnings.ca.gov)



**Series HAS Code**

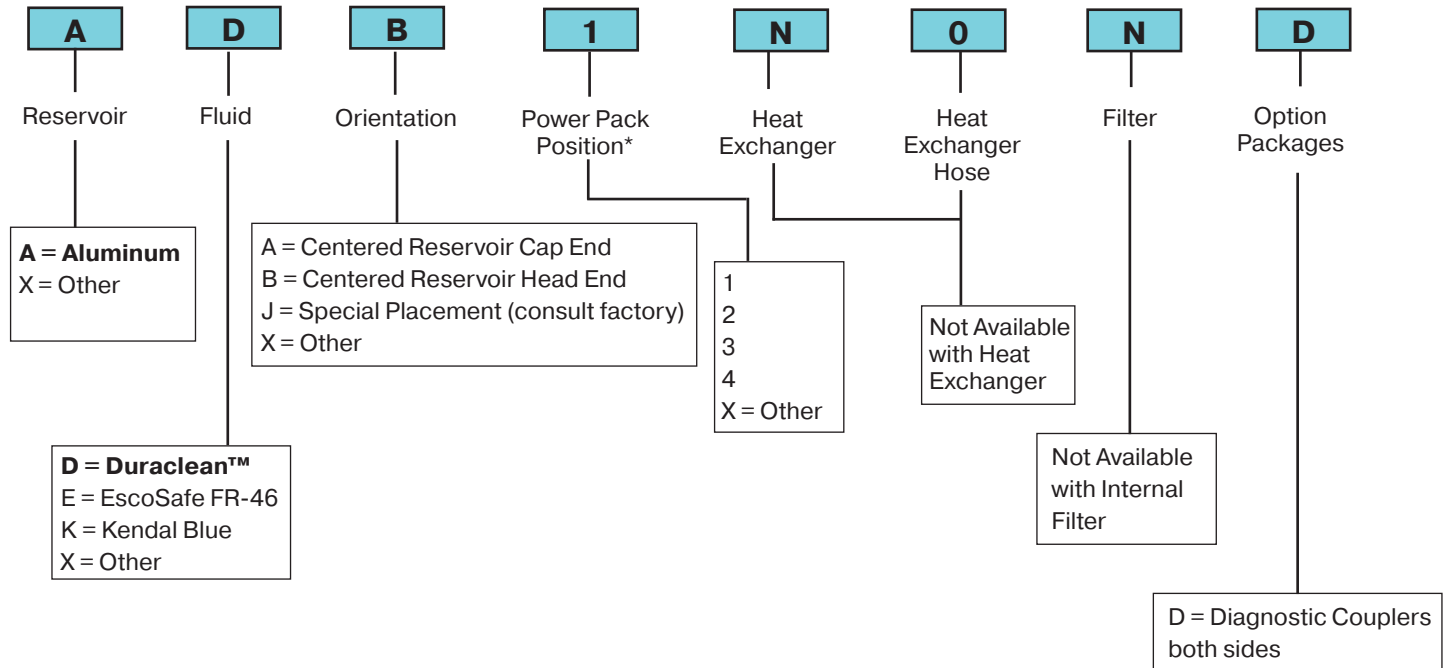

\*Power Pack Position Locations

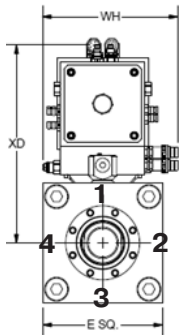

**⚠ PROP 65 WARNING** **WARNING:** This product can expose you to chemicals including Lead and Lead Compounds which are known to the State of California to cause cancer and birth defects or other reproductive harm. For more information go to [www.P65Warnings.ca.gov](http://www.P65Warnings.ca.gov)



**HS2 & HS3 Family Model Code / How to Order Installation Manual**

**HS2 & HS3 Family Model Code**

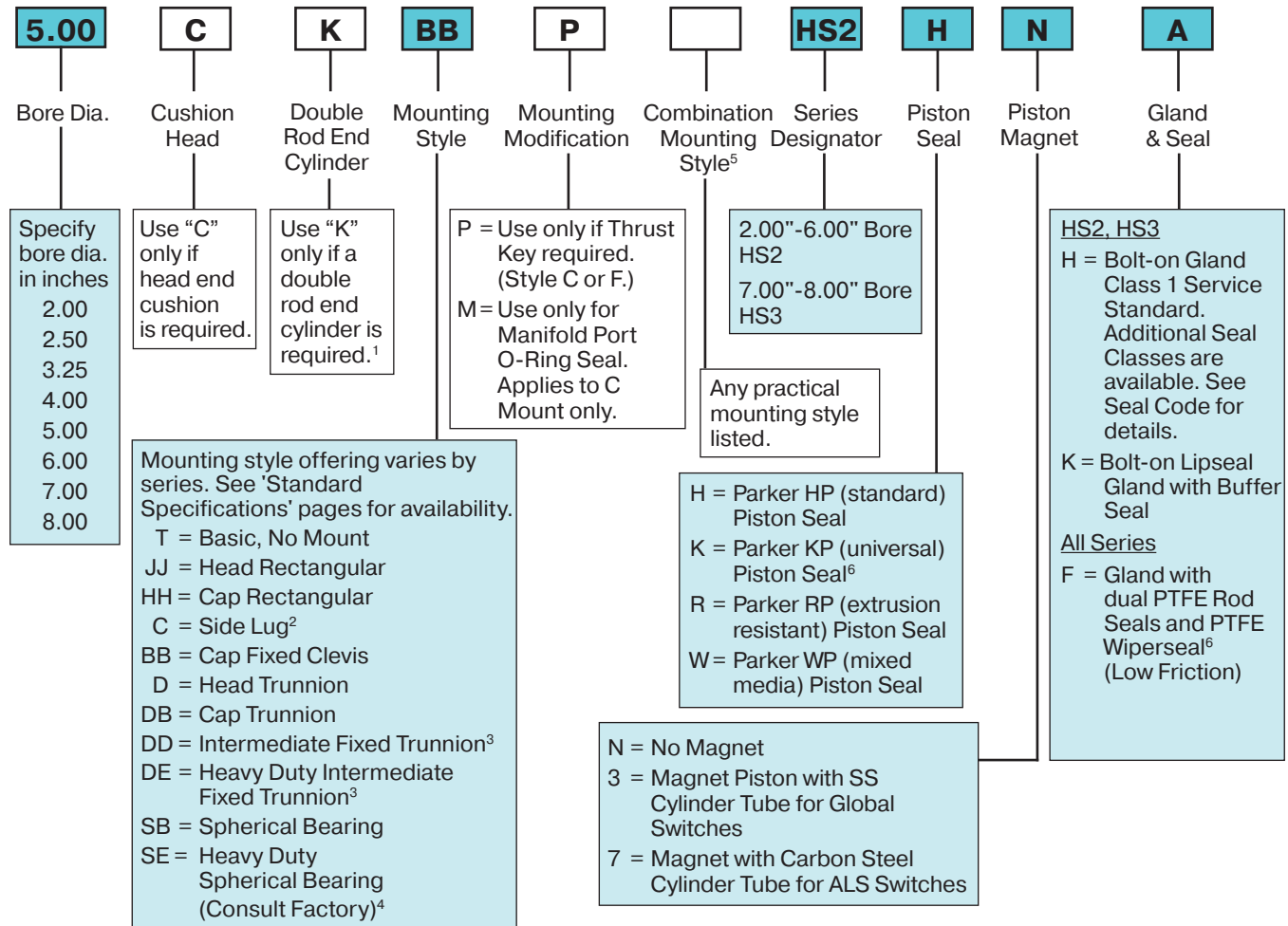

**Series HS2 / HS3 Minimum Stroke Table**

Bore	Centered Manifold Mount	Head/Cap Manifold Mount	
	All Mounts (Except DD)	All Mounts (except DD)	DD Mounts
2.00	9	2	4
2.50	9	2	4
3.25	9	2	5
4.00	9	2	5
5.00	9	2	6
6.00	10	3	7
7.00	11	4	9
8.00	11	3	9

Shaded boxes identify required model number fields.

<sup>1</sup> Available mounting styles for K Type cylinders are located at the end of Section A. When ordering a double rod end cylinder, the piston rod number and piston rod end threads are to be specified for both rod ends.

The model number should be created as viewing the primary rod end on the left hand side.

Example: K Type Cylinder:  
4.00CKTDHS2LT14A28AC10.000

<sup>2</sup> Mounting Styles C and F should have a minimum stroke length equal to or greater than their bore size.

<sup>3</sup> Specify XI dimension.

<sup>4</sup> Special mounting styles that do not resemble a standard catalog offering will be designated as style TX by the factory. Consult factory.

<sup>5</sup> In general, the model numbers as read left to right corresponding to the cylinder as viewed from left to right with the primary end at the left. The second or subsequent mountings are mountings called out as they appear in the assembly moving away from the rod end. Except when tie rod extension mountings are part of a combination, all combinations should have a "S" (Special) in the model code and a note in the body of the order clarifying the mounting arrangement. The "P", as used to define a thrust key is not considered to be a mounting. However it is located at the primary end.

<sup>6</sup> Piston seal code K and Gland & Seal code F must be selected for Class 8 service along with seal class 8.

**PROP 65 WARNING** WARNING: This product can expose you to chemicals including Lead and Lead Compounds which are known to the State of California to cause cancer and birth defects or other reproductive harm. For more information go to [www.P65Warnings.ca.gov](http://www.P65Warnings.ca.gov)



**HS2 & HS3 Family Model Code / How to Order Installation Manual**

**HS2 & HS3 Family Model Code**

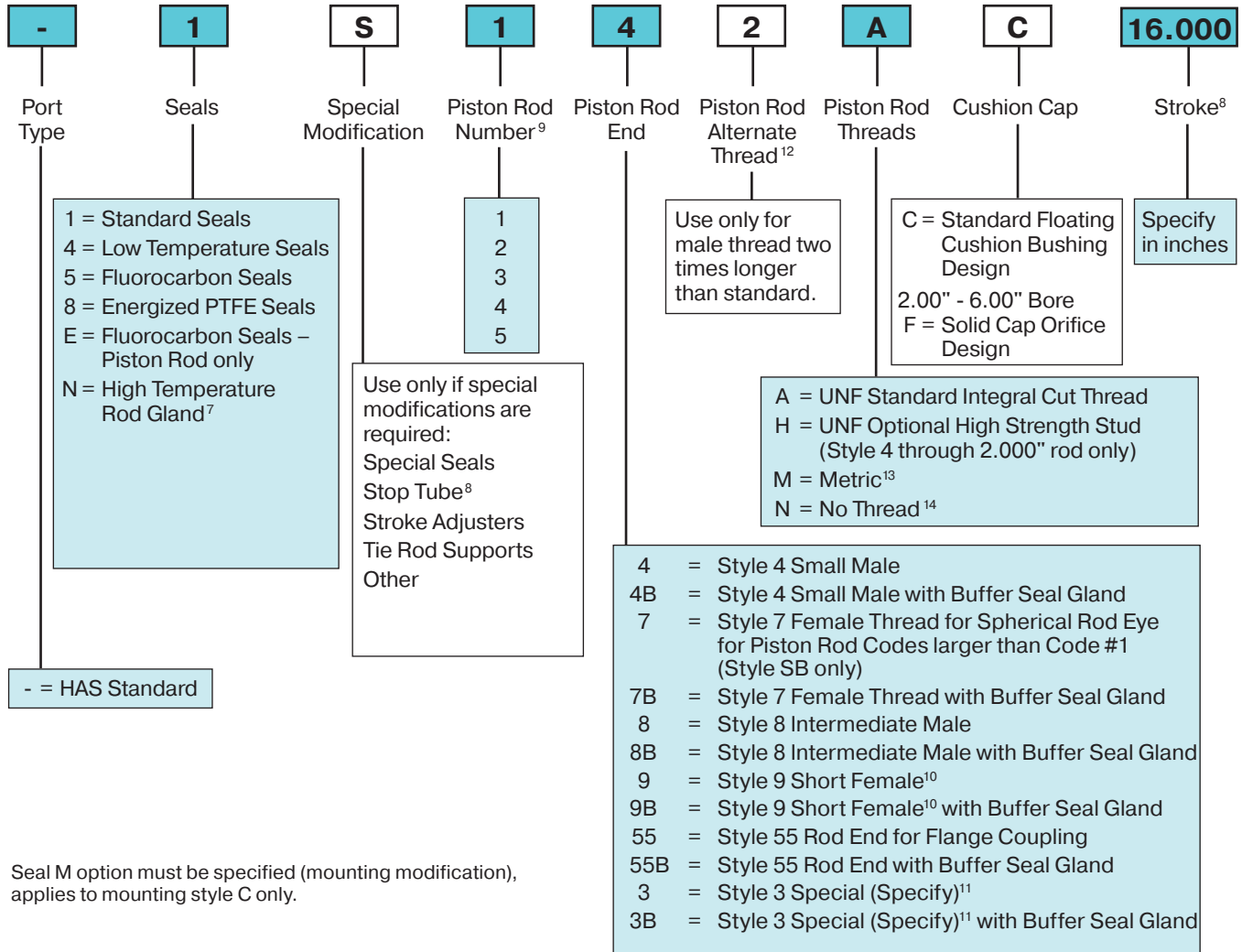

Shaded boxes identify required model number fields.

<sup>7</sup> Energized PTFE rod seals & wiperseal. All other cylinder seals are fluorocarbon.

<sup>8</sup> S = Stop Tube. Specify: stop tube length, net stroke and gross stroke. Gross stroke = stop tube length + net stroke. Gross stroke to be placed in the model number field.

Example:

2.000 inches long stop tube  
 +14.000 inches net stroke  
 16.000 inches gross stroke

See tables on these pages for minimum allowable strokes for Series HS2 and Piston Rod End Styles 9 & 9B.

<sup>9</sup> Refer to Rod buckling chart in Section H to assure rod number selected will not buckle under load.

<sup>10</sup> Style 9 stroke restrictions may apply. See Style 9 Minimum Stroke Table for details.

<sup>11</sup> Provide dimensions for KK, A, W or WF. If otherwise special, furnish dimensioned sketch.

<sup>12</sup> Available only in combination with Style 4 or Style 8.

<sup>13</sup> See Section G for detailed information regarding standard metric rod end thread sizes.

<sup>14</sup> Must be specified for Piston Rod End Style 55.

**Style 9 Minimum Stroke Table**

Bore Ø	Rod Ø	Minimum Stroke	
		Style 9	Style 9B
8.00	3.500	1.500	1.06
	4.000	1.500	1.06
	4.500	2.375	1.94
	5.000	2.875	2.06
	5.500	3.625	2.81

**PROP 65 WARNING** WARNING: This product can expose you to chemicals including Lead and Lead Compounds which are known to the State of California to cause cancer and birth defects or other reproductive harm. For more information go to [www.P65Warnings.ca.gov](http://www.P65Warnings.ca.gov)



**HS2X & HS3X Family Model Code**

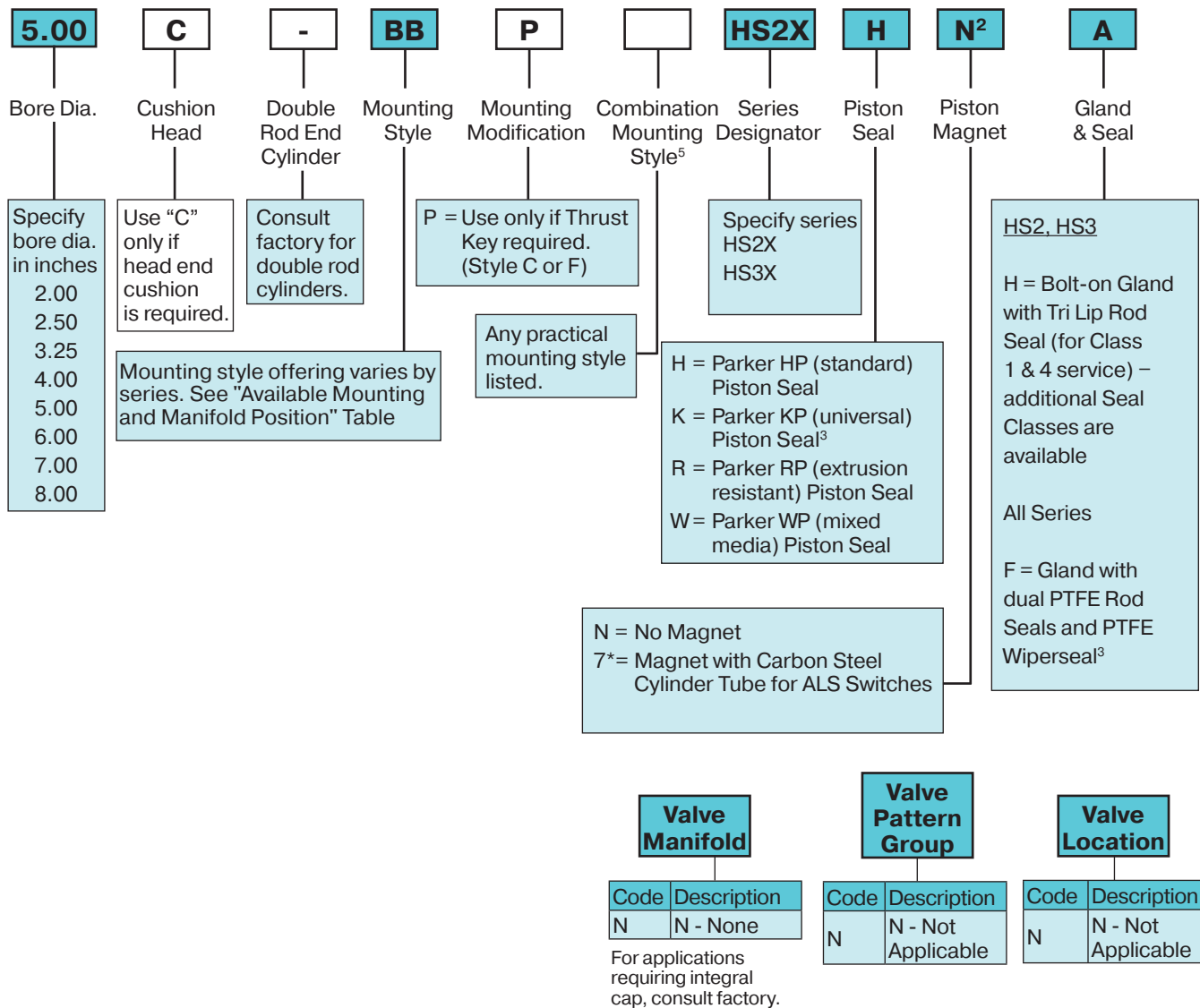

\*Note: Consult Factory, switch not available for end of stroke measurement due to retaining flange. Stroke to go sensing only. For end of stroke indication, use EPS or CLS switch options

Shaded boxes identify required model number fields.

- <sup>1</sup> Cap end cushion not available on LRT or WaveScale. Solid Cushion Orifice Design = F is not available on cylinders with probes but is available for Bolt on Manifolds.
- <sup>2</sup> Magnets are not available for cylinders with probes.
- <sup>3</sup> Piston seal code K and Gland & Seal code F must be selected for Class 8 service along with seal class 8..

Note:  
Consult current 2H/3H Family catalog HY08-1314 and 2HX / 3HX catalog HY08-1175 for complete dimensions, specifications and model number information.

**PROP 65 WARNING** **WARNING:** This product can expose you to chemicals including Lead and Lead Compounds which are known to the State of California to cause cancer and birth defects or other reproductive harm. For more information go to [www.P65Warnings.ca.gov](http://www.P65Warnings.ca.gov)



**HS2X & HS3X Family Model Code**

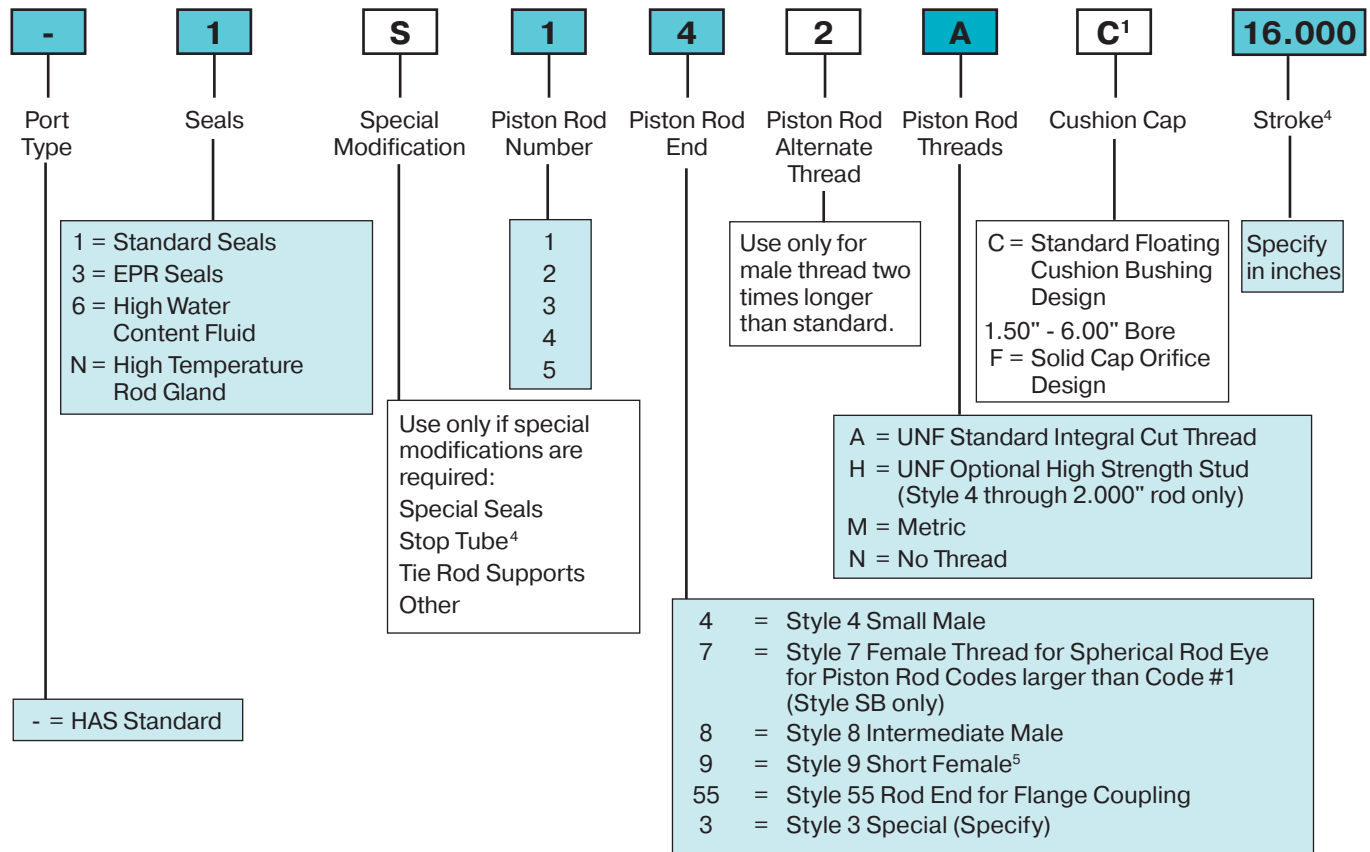

**Feedback Option**

Code	Description
N	N - None
C	C - MTS LDT
F	F - LRT
B	B - Balluff LDT
W	W - WaveScale
X	X - Other, Please Specify

**Feedback Furnished**

Feedback Furnished		Feedback Options		
Code	Description	C	B	W
NF	NF - No Feedback			
1P	1P - Prepare to Accept - Piston rod will be drilled to accept a probe with an electrical stroke equal to the cylinder net stroke.	3	3	
FR	FR - LRT Installed			
V0	V0 - 0 Vdc to +10 Vdc	3	3	3
V1	V1 - +10 Vdc to 0 Vdc	3	3	3
A0	A0 - 4 mA to 20 mA	3	3	3
A1	A1 - 20 mA to 4 mA	3	3	3
A4	A4 - Other Analog - Specify required output.	3	3	3
DE	DE - PWM, External Interrogation	3	3	
DI	DI - PWM, Internal Interrogation	3	3	
SS	SS - SSI Output <sup>6</sup>	3	3	3
R0	R0 - Start/Stop	3	3	
D4	D4 - Other Digital - Specify required output.	3	3	3

**Feedback Protective Enclosures**

Code	Description
N	N - Not Applicable
A	A - False Stage for LDT probes with integral cable
B	B - False Stage for LDT probes with connector and separate cable
D	D - Light Duty Cover
F	F - Medium Duty Cover for LDT probes with integral cable
G	G - Medium Duty Cover for LDT probe with connector and separate cable

<sup>4</sup> S = Stop Tube. Specify: stop tube length, net stroke and gross stroke. Gross stroke = stop tube length + net stroke. Gross stroke to be placed in the model number field.

Example:

2.000 inches long stop tube  
+14.000 inches net stroke  
16.000 inches gross stroke

See tables for minimum allowable strokes and female Piston Rod End Styles.

<sup>5</sup> Style 9 stroke restrictions may apply.

<sup>6</sup> Refer to the "How To Order" page for information required for CAN and SSI output, Catalog HY08-1175-2.

**PROP 65 WARNING** **WARNING:** This product can expose you to chemicals including Lead and Lead Compounds which are known to the State of California to cause cancer and birth defects or other reproductive harm. For more information go to [www.P65Warnings.ca.gov](http://www.P65Warnings.ca.gov)



**HSR Model Code**

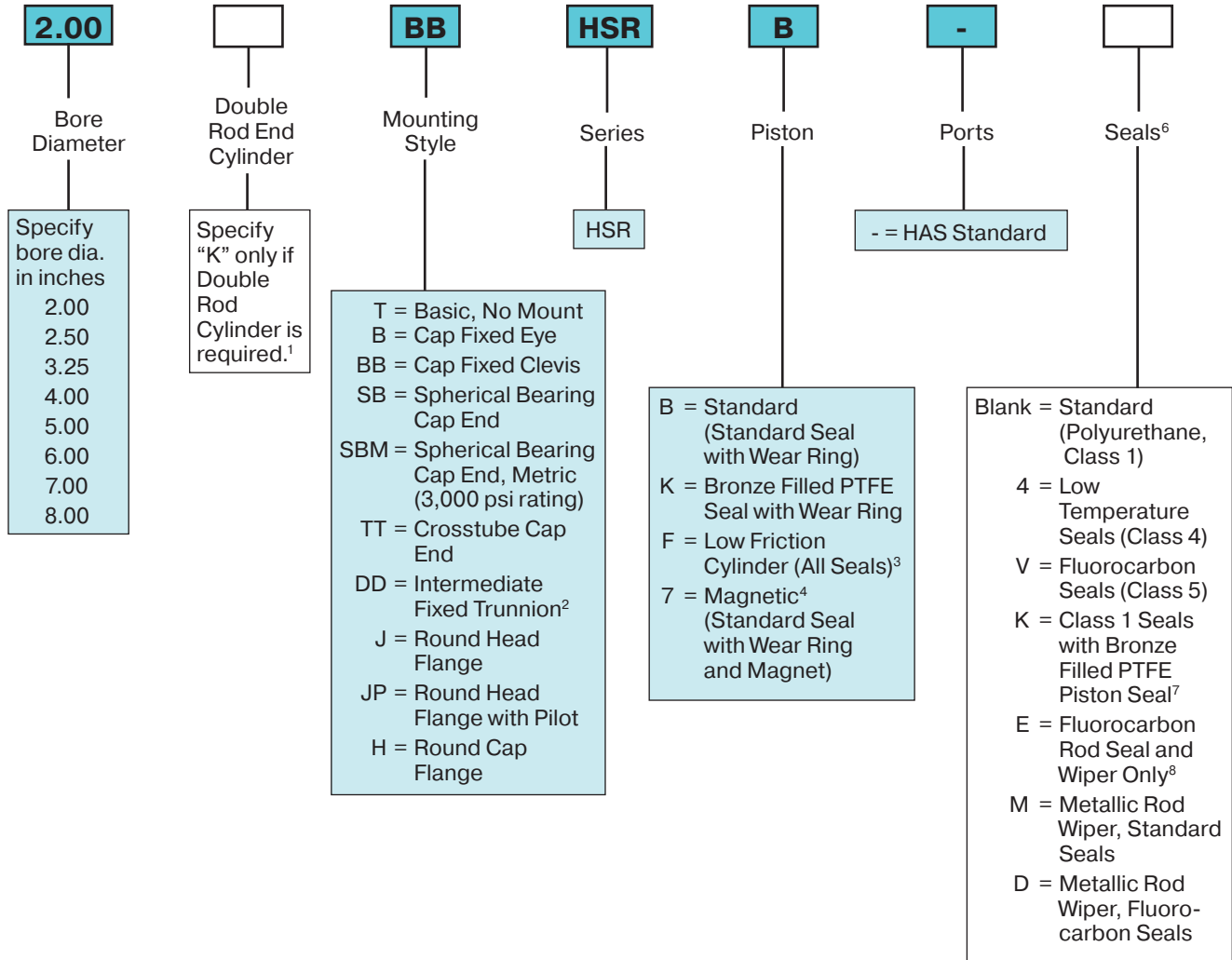

Shaded boxes identify the required model number fields.

<sup>1</sup> Available standard mounting styles for K-type cylinders are T, DD and J/JP. When ordering a double rod cylinder, the piston rod number and piston rod thread style must be specified for both rod ends. The model number should be created as viewing the primary rod end on the left-hand side.

Example of a K-type cylinder:

4.00**K**DDHSRBT1 **A28A**10.000

<sup>2</sup> Specify XI dimension. See minimum and maximum XI dimensions on DD Intermediate Fixed Trunnion Mounting Page.

<sup>3</sup> Includes low friction seals for the entire cylinder. Available with standard seals and Seal codes 2, X, 4, V and H.

<sup>4</sup> Used with externally mounted ALS Switches. Includes seal and wear ring from standard piston. Available for 2" to 6.00" bore diameters. Switch operating temperature range is -13°F to +185°F. Switch position may be restricted for Mounting Style DD. Consult factory for other options.

<sup>5</sup> See Seal Information pages for additional information.

<sup>6</sup> Option used for Piston code 7 (Magnetic Piston).

<sup>7</sup> Used for external chemical compatibility applications, not high temperature.

**PROP 65 WARNING** WARNING: This product can expose you to chemicals including Lead and Lead Compounds which are known to the State of California to cause cancer and birth defects or other reproductive harm. For more information go to [www.P65Warnings.ca.gov](http://www.P65Warnings.ca.gov)



**HSR Model Code**

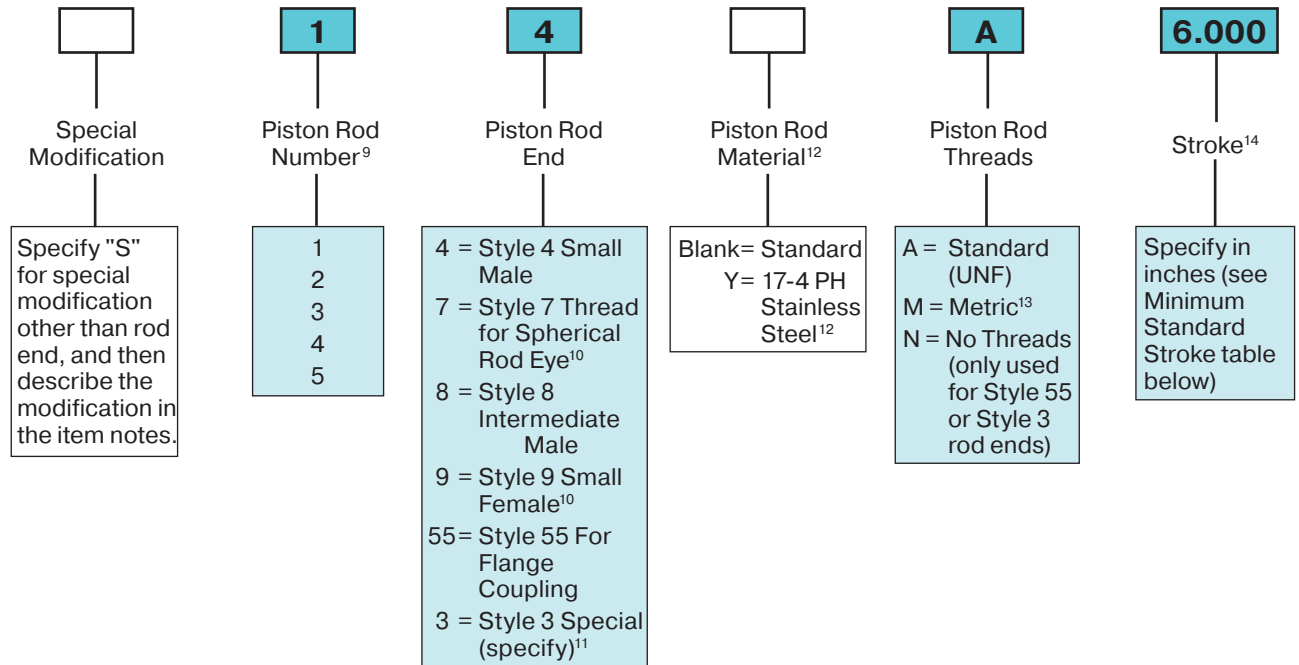

**Minimum Standard Stroke**

Bore	Centered Manifold Mount	Head/Cap Manifold Mount	
	All Mounts (Less DD)	All Mounts (Less DD)	DD Mounts
2.00	9.95	2.95	4.95
2.50	10.12	3.12	5.12
3.25	10.44	3.44	6.44
4.00	10.25	3.25	6.25
5.00	10.69	3.69	7.69
6.00	11.88	4.88	8.88
7.00	13.38	6.38	11.38
8.00	14.13	6.13	12.13

Shaded boxes identify the required model number fields.

<sup>9</sup> Refer to the Stop Tubing and Piston Rod Selection Data pages in Catalog HY08-1320 to assure that the selected rod number will not buckle under load.

<sup>10</sup> Style 7A (UNF threads) and Style 9 may require a minimum stroke. See Minimum Standard Stroke in table to the left for details.

<sup>11</sup> Provide desired dimensions for KK (or CC), A and W. If otherwise special, supply a dimensioned sketch. Accessories welded to the rod end are available.

<sup>12</sup> Other stainless steels (i.e. 303, 316) are available with a derated maximum operating pressure; consult factory.

<sup>13</sup> For Style 7M, see page 15 Catalog HY08-1320 for details. For Styles 4M, 8M and 9M, see page 36 for details.

<sup>14</sup> If a stop tube is required, specify **gross stroke** (net stroke + stop tube length) in the model number field, then place an "S" for special in the Special Modification field and specify the stop tube length in the item notes. For stroke length tolerance, see Stroke Data page in Catalog HY08-1320.

**⚠ PROP 65 WARNING** **WARNING:** This product can expose you to chemicals including Lead and Lead Compounds which are known to the State of California to cause cancer and birth defects or other reproductive harm. For more information go to [www.P65Warnings.ca.gov](http://www.P65Warnings.ca.gov)



# Surface Protection

## Base Cylinders:

The base cylinder may be ordered with various rod materials and plating options.

Chrome Plated is standard rod plating. Heavy chrome and Global Shield coating optional

The base cylinder is painted Black Enamel. Additional options available.

## Hydraulic Flow Tubes:

Hydraulic Flow tubes are Black Oxide plated for corrosion protection

## HAS Power Pack components:

Reservoir End Cap, Upper Manifold, Motor Mounting Plate and Lower Manifold are manufactured from 6061/6262 aluminum and are black anodized type II (sulfuric) per MIL-A-8625.

Reservoir and Pump shroud are manufactured from 6063/6061 aluminum with clear hard coating (Electrolytically formed and bonded aluminum oxide)

HAS Power pack components are not painted.



**PROP 65 WARNING**

**WARNING:** This product can expose you to chemicals including Lead and Lead Compounds which are known to the State of California to cause cancer and birth defects or other reproductive harm. For more information go to [www.P65Warnings.ca.gov](http://www.P65Warnings.ca.gov)



# HAS 500 Component Identification

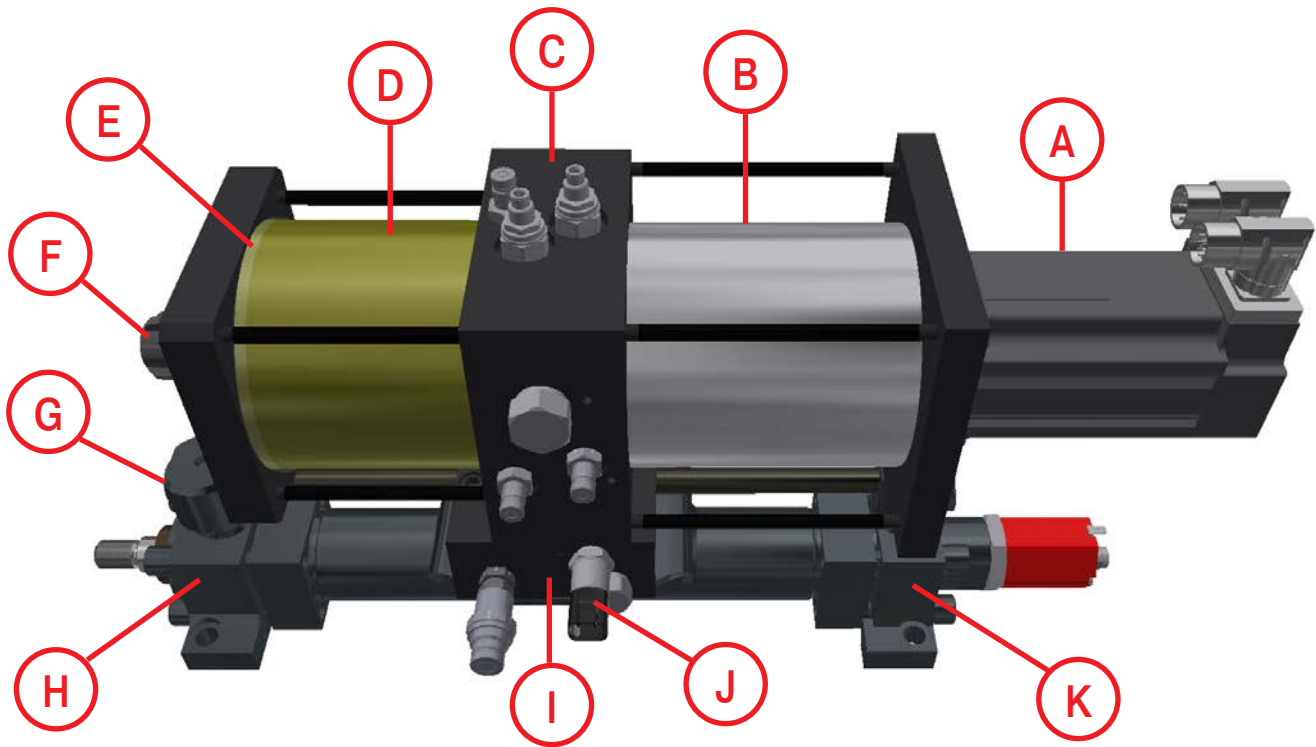

Item	Description
A	Electric Motor, AC or DC version (PMAC shown)
B	Pump Shroud
C	Upper Manifold - Pump Control
D	Reservoir
E	Reservoir Bladder
F	Reservoir Vent Cap
G	Weld Spud
H	Cylinder "Head" End
I	Lower Manifold - Circuit
J	Options - Pressure Transducers
K	Cylinder "Cap" End

**⚠ PROP 65 WARNING** **WARNING:** This product can expose you to chemicals including Lead and Lead Compounds which are known to the State of California to cause cancer and birth defects or other reproductive harm. For more information go to [www.P65Warnings.ca.gov](http://www.P65Warnings.ca.gov)

# HAS-ST Component Identification

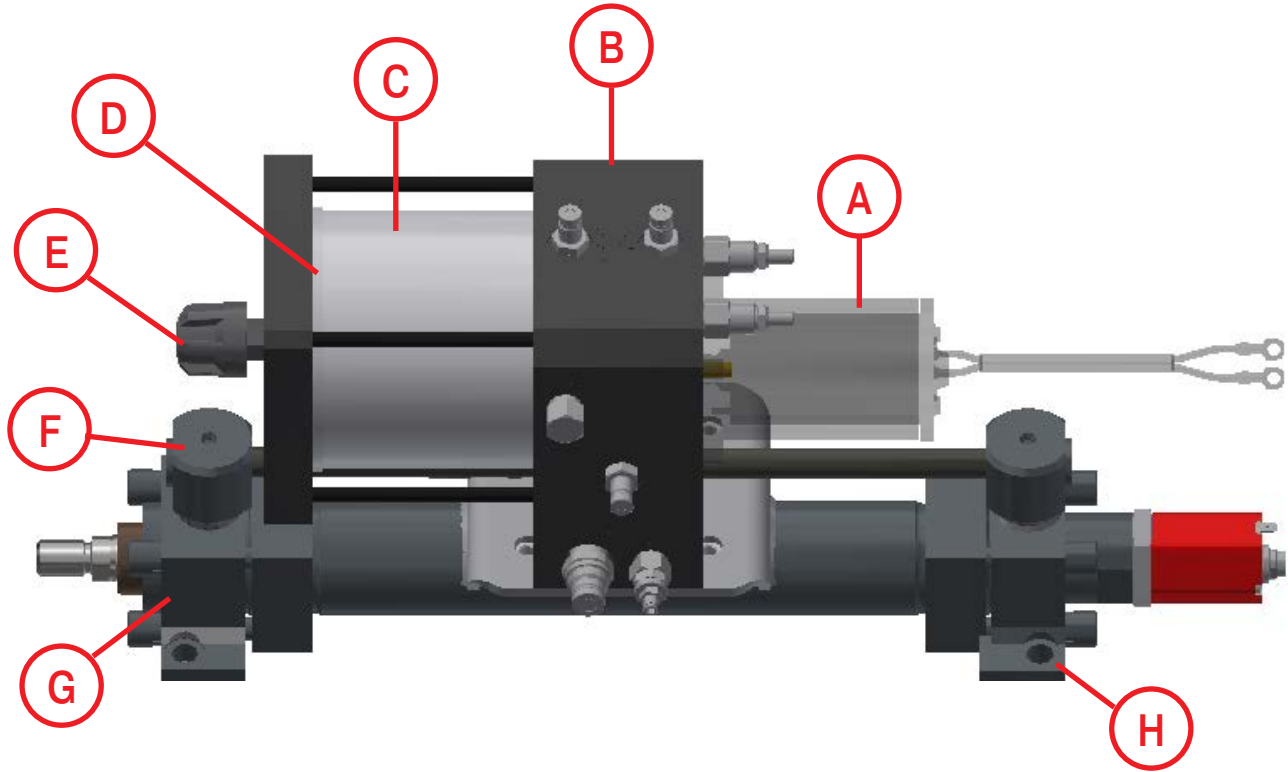

Item	Description
A	Electric Motor, 24V DC
B	Upper Manifold - Pump Control
C	Reservoir
D	Reservoir Bladder
E	Reservoir Vent Cap
F	Weld Spud
G	Cylinder "Head: End
H	Cylinder "Cap" End

**⚠ PROP 65 WARNING** **WARNING:** This product can expose you to chemicals including Lead and Lead Compounds which are known to the State of California to cause cancer and birth defects or other reproductive harm. For more information go to [www.P65Warnings.ca.gov](http://www.P65Warnings.ca.gov)

# HAS Operating Temperature

## Operating Temperature

Base Cylinder				
Seal (class)	1	4	5	8
Description	Standard	Low Temp	Fluorocarbon	High Temp
Fahrenheit	-10 to 165	-50 to 150	-10 to 300	-15 to 400
Celsius	-23 to 74	-46 to 66	-23 to 149	-26 to 204

Description	Crown Wiper	LDTs	ALS Switches	EPS Switches
Fahrenheit	-5 to 240	-40 to 176	-13 to 185	-14 to 158
Celsius	-20 to 115	-40 to 80	-25 to 85	-25 to 70

## HAS Power Pack

Description	ST Pump	500 Pump	Static Seals	Cartridge Valves	Reservoir Bag
Fahrenheit	-30 to 150	-40 to 158	-20 to 225	-20 to 225	-40 to 225
Celsius	-34 to 65	-40 to 70	-30 to 107	-30 to 107	-40 to 107

Motors	A Series	D Series	F Series	M Series
Fahrenheit	-4 to 194	-40 to 158	-40 to 158	-30 to 150
Celsius	-20 to 90	-40 to 70	-40 to 70	-34 to 65
Custom	-50 to 90			

## Controllers

	D Series Inverter	A Series Drives		
	99170**	AC890	AC30	C3S
Fahrenheit	-40 to 131	32 to 113	32 to 104	32 to 113
Celsius	-40 to 70	0 to 45	0 to 40	0 to 45

**⚠ PROP 65 WARNING** **WARNING:** This product can expose you to chemicals including Lead and Lead Compounds which are known to the State of California to cause cancer and birth defects or other reproductive harm. For more information go to [www.P65Warnings.ca.gov](http://www.P65Warnings.ca.gov)

# HAS Fluids

## Operating Temperature and Conditions

Pump	PGP505	PGP511	PG517
Ideal Inlet (in-HG)	23.6		
Min Inlet - Intermittent (in-HG)	14.7		
Max Inlet - ST Shaft Seal (PSI)	29		
Max Inlet - High PSI Seal (PSI)	60		
Fluid Temp (F)	5 - 176		
Fluid Viscosity (cST)	8 - 1000		
Ambient Temp Range (F)	-40 to 158		
Fluid Filtration	19/17/13		

## Fluid Selection

Fluid selection is important to ensure proper operation and life of the HAS unit. A fluid that is too viscous, (cooler temperatures) cause higher pressure drops and pump cavitation. Lighter fluids with low-viscosity permit attractive viscosity at lower temperatures, however at normal and elevated temperatures the thinner fluid reduces volumetric efficiency and promotes more internal leakage. At elevated temperatures, the thinner fluid viscosity thins out below acceptable levels for proper pump operation and lubrication.

Fluid	DuraClean	EcoSafe FR-46	Hyken Glacial Blu	Pentosin CHF 115
ISO Grade	Multigrade 46	46	15	
Specific Gravity @ 60F	0.867	0.99	0.867	
Density g/cm <sup>3</sup>		0.99	0.866	0.825
Color, Visual	Gold	Clear Blue	Blue	Dark Green
Flash Point (COC) ° F	413° F	534	253	320
cSt @ 40C	44.3	50	15	18.7
cSt @ 100C	7.65	9.45	4.5	6
SUS @ 100F		255	77.4	
SUS @ 210F		57.3	40.2	
Viscosity Index	141	176	244	
Pour Point (F)	-42	-49	-81	-76.6
Environmental				
Biodegradability, 28 Days		0.902		
Aquatic Toxicity		"Practically Non-toxic"		

EcoSafe S3 DU fluid, formerly EcoSafe FR46 full synthetic fire resistance,  
 Readily Biodegradable fluids that are Factory Mutual Approved fire resistance

**⚠ PROP 65 WARNING** **WARNING:** This product can expose you to chemicals including Lead and Lead Compounds which are known to the State of California to cause cancer and birth defects or other reproductive harm. For more information go to [www.P65Warnings.ca.gov](http://www.P65Warnings.ca.gov)



## Fluid Selection

HAS units can operate with multiple fluid options. We have standardized on three fluid choices that cover most of the application needs: Parker DuraClean, Shell EcoSafe and Kendall Glacial Blu.

Recommended use is **Parker DuraClean**. This fluid has a unique additive chemistry, perfect for use in HAS units. The special formulation for rapid air release, anti-foam agent, start clean-stay clean technology make it the right choice for use with Hybrid Actuation System.

**EcoSafe FR** fluids are fully synthetic, non-aqueous fluid that are Factory Mutual approved for HazLoc applications. This fluid satisfies the stringent requirements for biodegradable and toxicity. EcoSafe FR fluid meet or exceed Parker specifications and should be selected when Fire resistant or Biodegradable requirements exist.

**Kendal Blu** fluids are low-viscosity fluids for extremely cold climates. Fluids no longer available for HAS applications, primarily used in Solar Tracking application. New applications should use Pentosin.

**Pentosin CHF 11S** fluids are synthetic fluids for extremely cold climates. Due to the low viscosity, pump speeds may be limited and efficiencies will be reduced. Consult factory for additional information

### Fluid Viscosity at Normal Temperatures

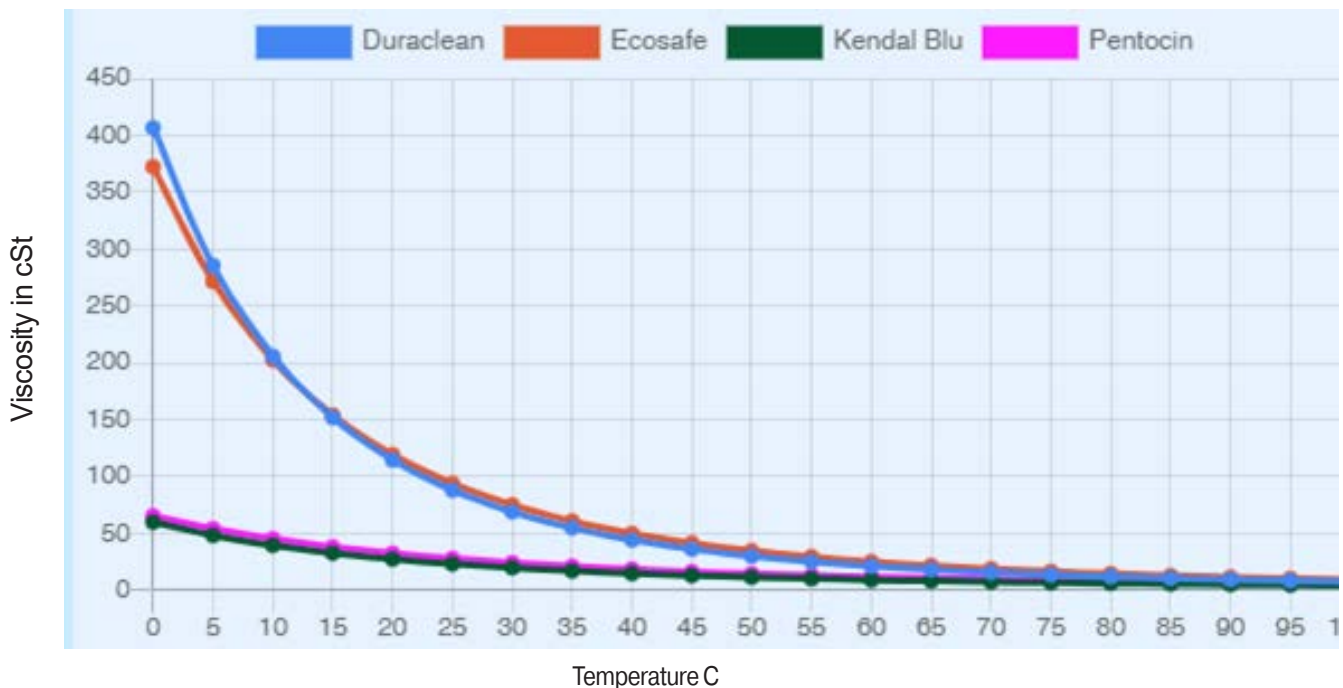

When selecting fluid for a HAS actuator, fluid viscosity at temperature must be greater than 10 cSt and less than 1000 cSt.

**⚠ PROP 65 WARNING** **WARNING:** This product can expose you to chemicals including Lead and Lead Compounds which are known to the State of California to cause cancer and birth defects or other reproductive harm. For more information go to [www.P65Warnings.ca.gov](http://www.P65Warnings.ca.gov)

### Fluid Viscosity at High Temperature

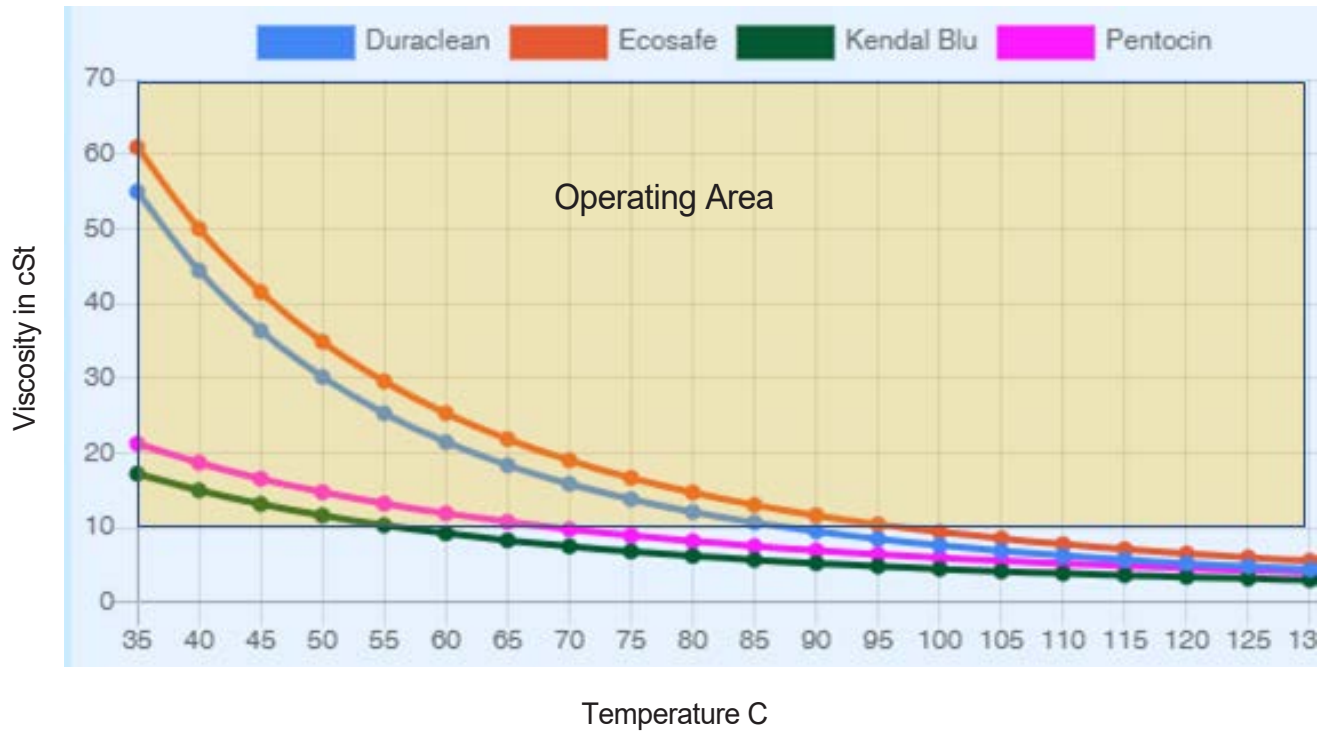

### Fluid Viscosity at Cold Temperature

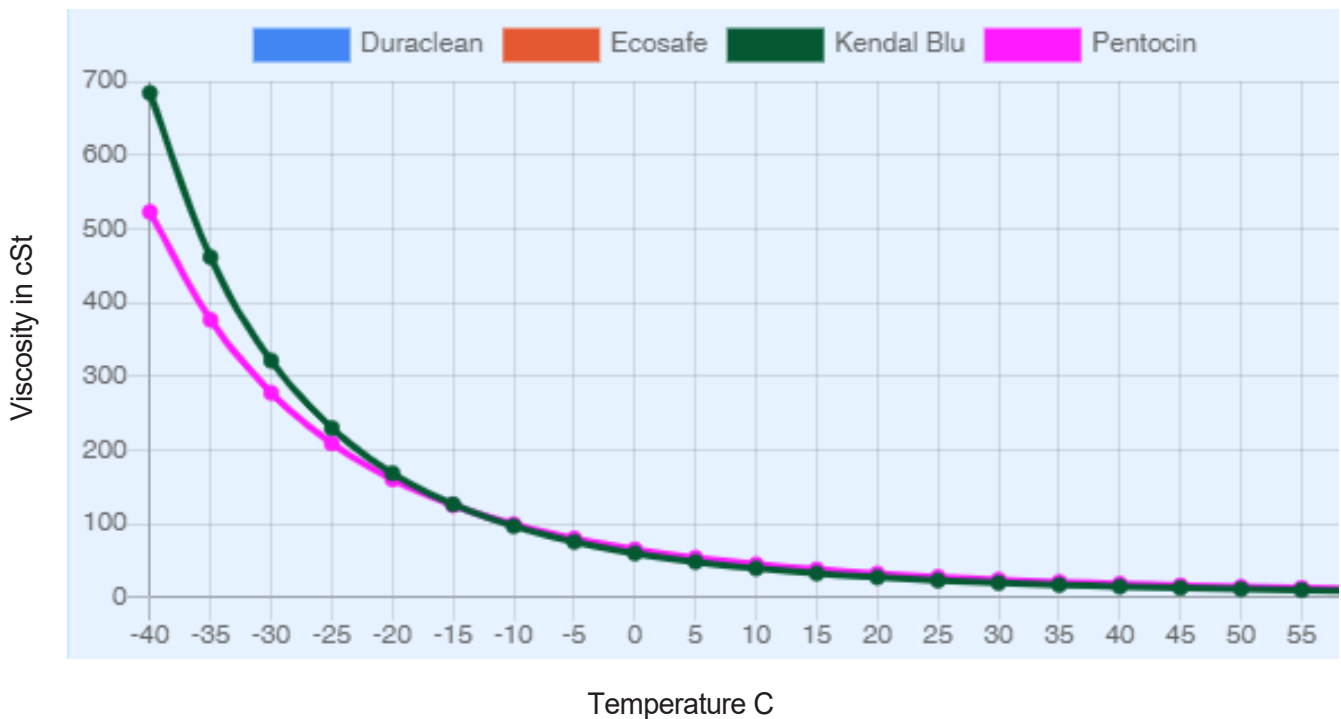

When selecting fluid for a HAS actuator, fluid viscosity at temperature must be greater than 10 cSt and less than 1000 cSt.

**PROP 65 WARNING** WARNING: This product can expose you to chemicals including Lead and Lead Compounds which are known to the State of California to cause cancer and birth defects or other reproductive harm. For more information go to [www.P65Warnings.ca.gov](http://www.P65Warnings.ca.gov)

## Use of HAS Units at High Elevations

HAS units can operate at high elevations, but do require some additional evaluation. At higher elevations atmospheric pressure decreases causing the fluid to carry less weight resulting in reduced pressure. To ensure the HAS pump does not cavitate we must ensure proper pump inlet conditions are met at application elevations.

The charts listed below are broken into 2 categories: Dynamic and Relief Pressures. Based upon unequal area cylinders with Parker DuraClean Fluid. Consult Factory for equal area (double rod) cylinders.

Dynamic Conditions are based upon a 1.9:1 ratio cylinder, Cap end area is 1.9 times larger than the head end area, typically a code 3 rod size. The pump must draw 53% of the fluid from the reservoir to make up the difference. In retract or Pull conditions, the pump inlet is "boosted" as there is more volume in return than extend, and isn't a concern.

Relief Pressures are based upon entire pump volume being drawn from the reservoir. This condition should be avoided if possible, but certain applications may require pressures to meet the relief condition to ensure cylinders are fully extended or retracted. When this condition is required refer to the relief charts below.

To use the chart, with known pump size, determine the trace color by the value closest to the elevation the HAS unit will be installed at. Secondly determine the pump shaft speed limit, when the traces is above the Red horizontal line. Ideally closer to or above the green line is preferred. Dynamic Traces are solid, Relief Traces are dashed.

All high elevation applications should be low duty cycle intermittent use.

**Contact Factory for special drive kit with appropriate speed limitation.**

**Series A Motors (MPP)** are suitable for operation up to 1600 meters above sea level.  
Consult factory for higher elevation requirements

**0991760 Drive Kits (A series motors)** If greater than 1000 meters above sea level, maximum operating current by 1% per 100 meters, to a maximum of 2000 meters above sea level.

**Series D motors and Inverters (099170 drive kits)** are suitable for operation up to 4000 meters above sea level.

 **PROP 65 WARNING** **WARNING:** This product can expose you to chemicals including Lead and Lead Compounds which are known to the State of California to cause cancer and birth defects or other reproductive harm. For more information go to [www.P65Warnings.ca.gov](http://www.P65Warnings.ca.gov)

# Inlet vs Elevation Charts

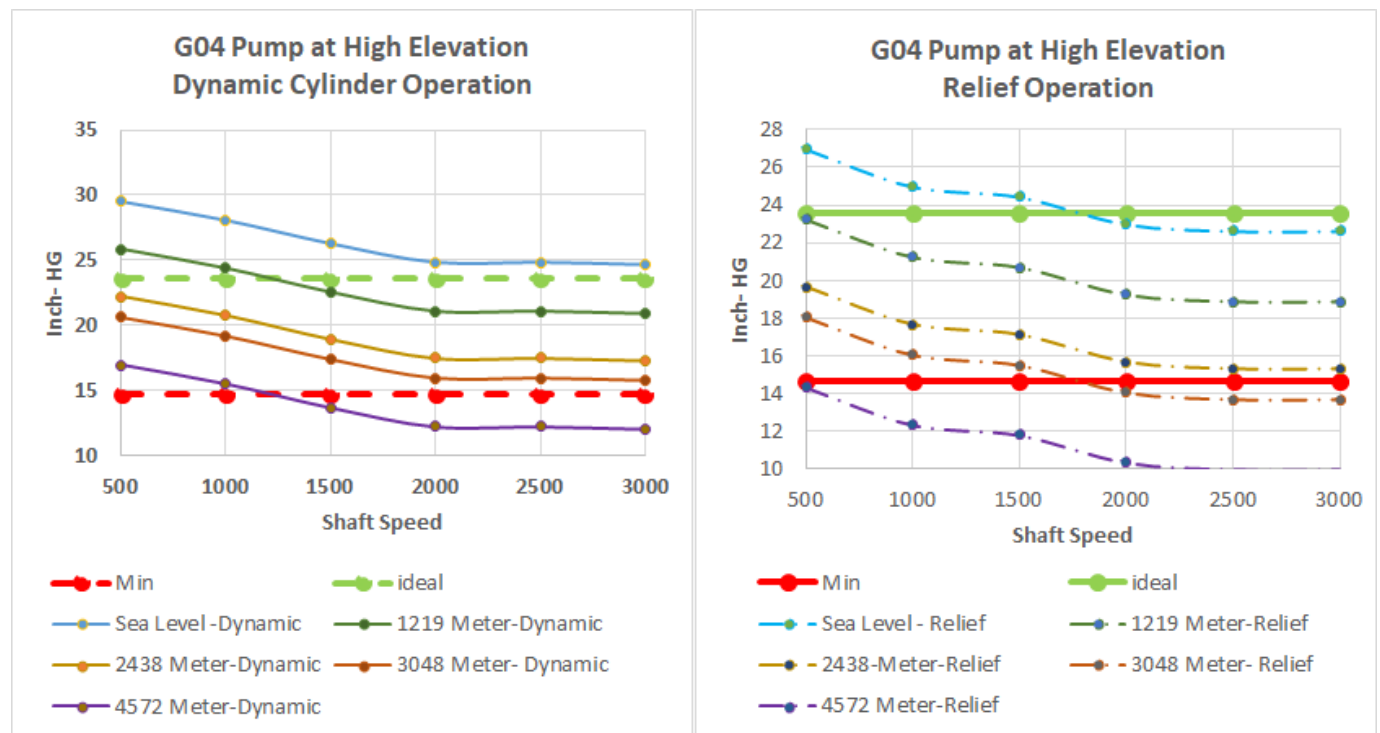
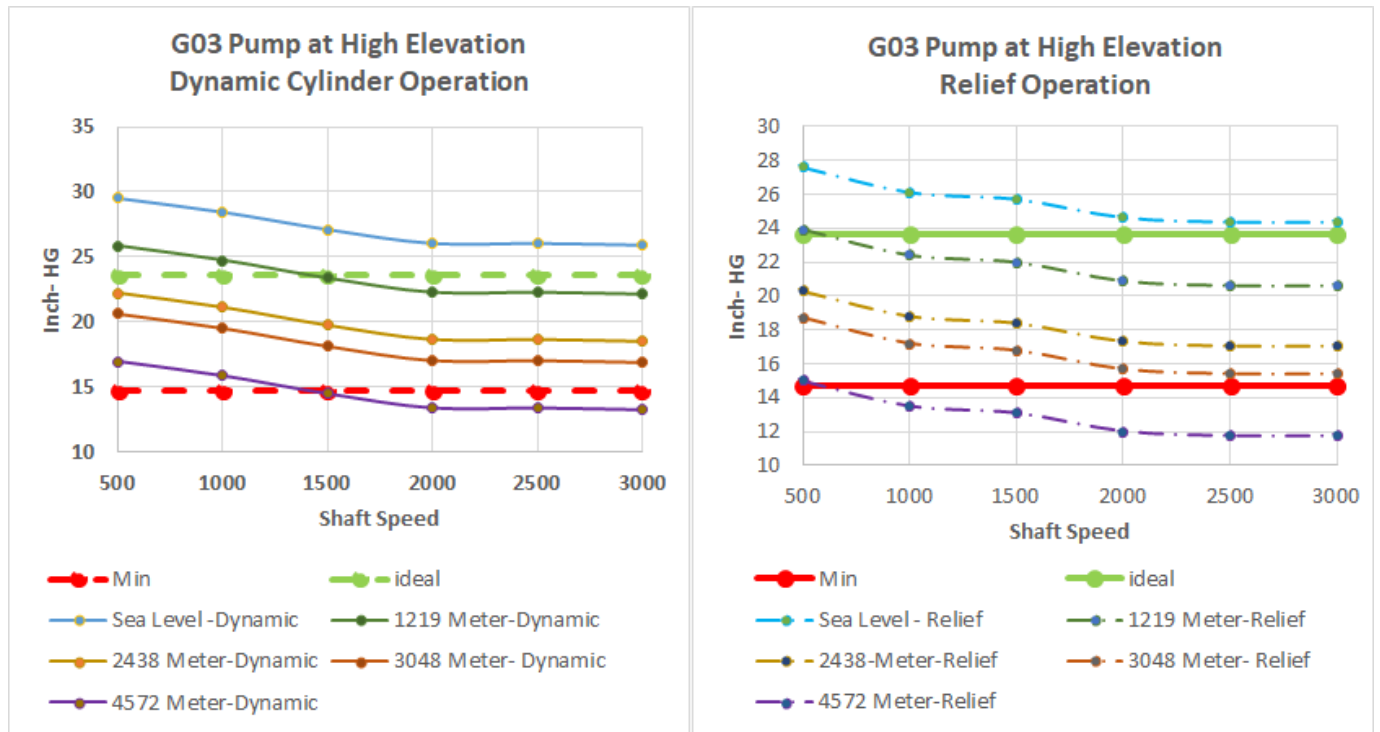

**PROP 65 WARNING** WARNING: This product can expose you to chemicals including Lead and Lead Compounds which are known to the State of California to cause cancer and birth defects or other reproductive harm. For more information go to [www.P65Warnings.ca.gov](http://www.P65Warnings.ca.gov)



# Inlet vs Elevation Charts

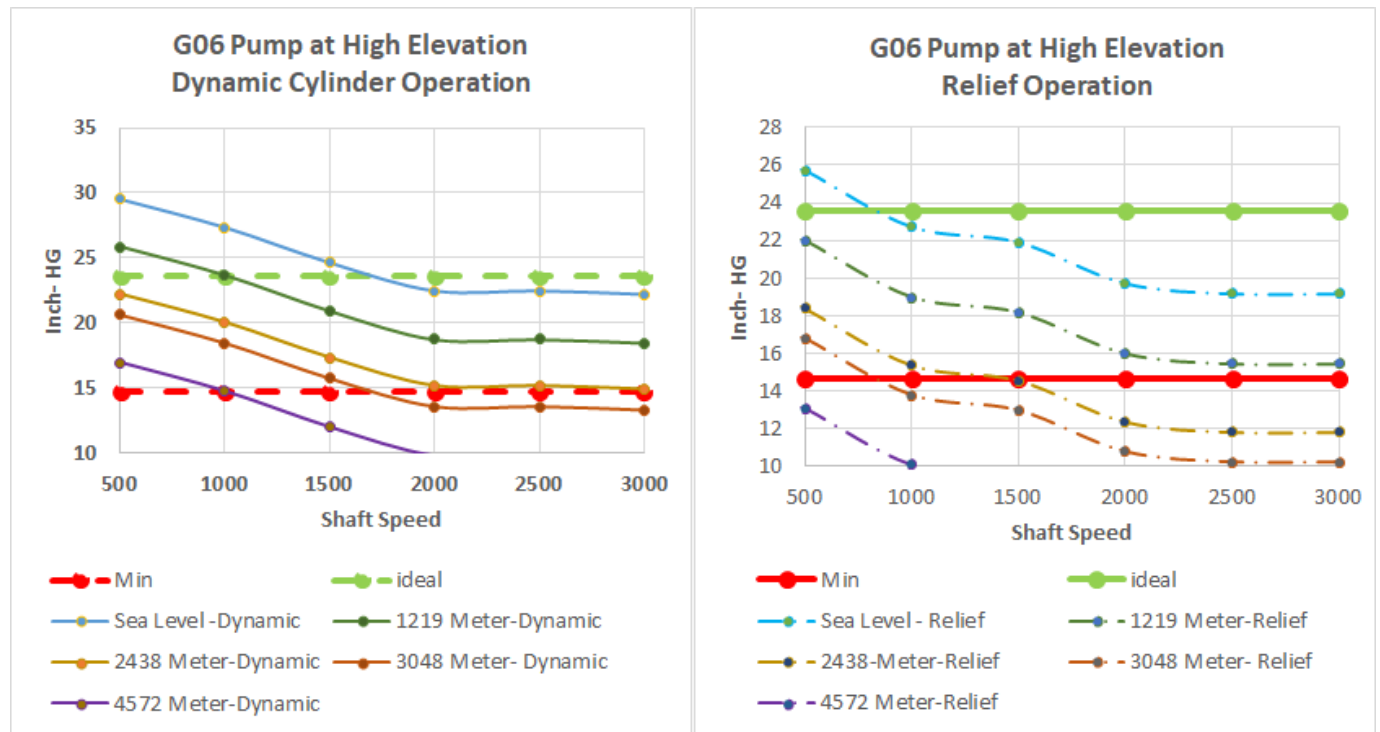
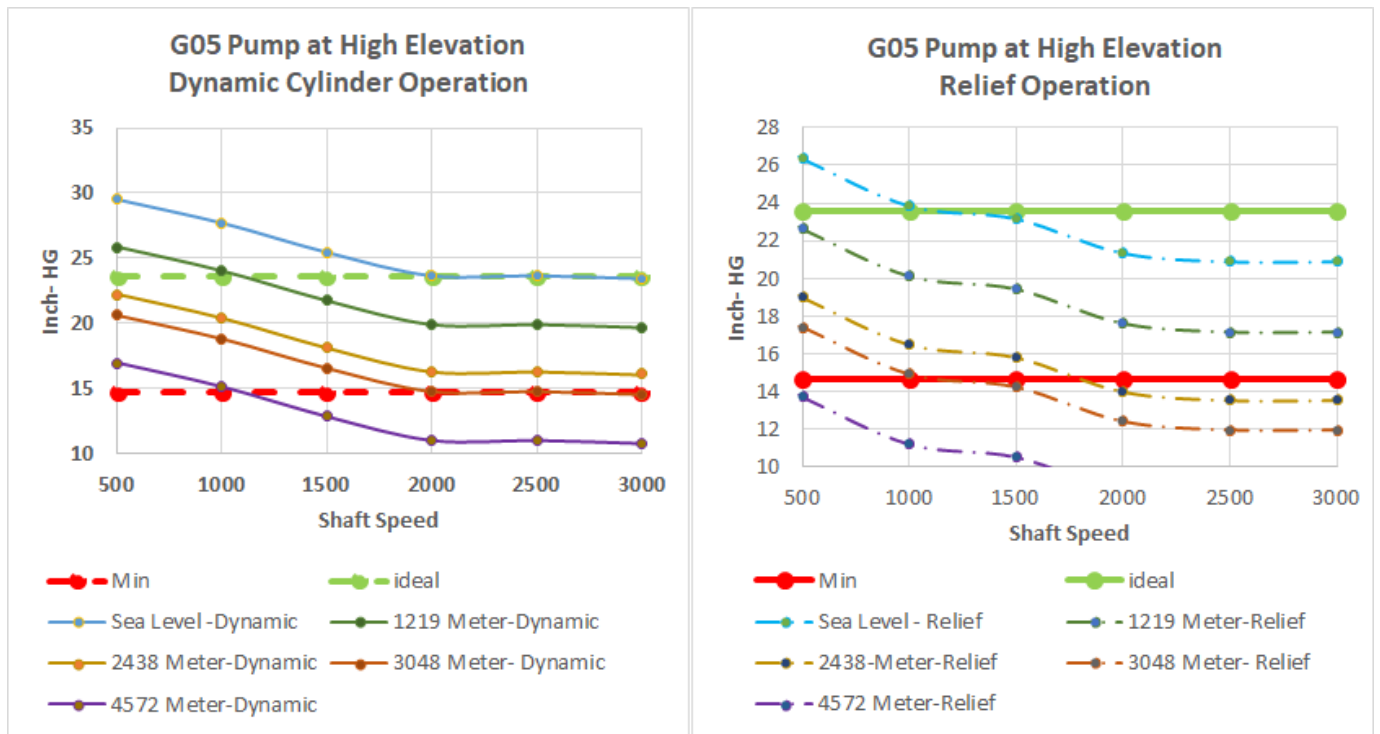

**⚠ PROP 65 WARNING** **WARNING:** This product can expose you to chemicals including Lead and Lead Compounds which are known to the State of California to cause cancer and birth defects or other reproductive harm. For more information go to [www.P65Warnings.ca.gov](http://www.P65Warnings.ca.gov)



# Inlet vs Elevation Charts

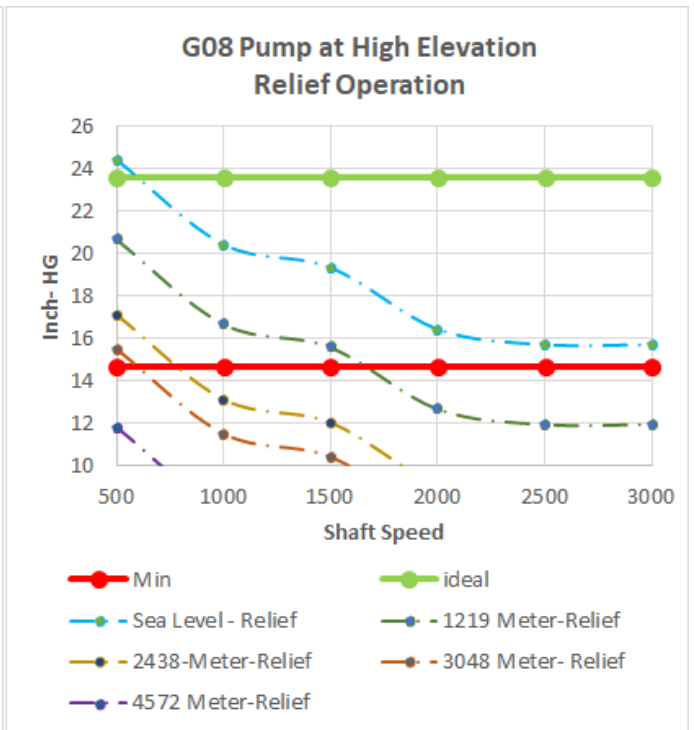
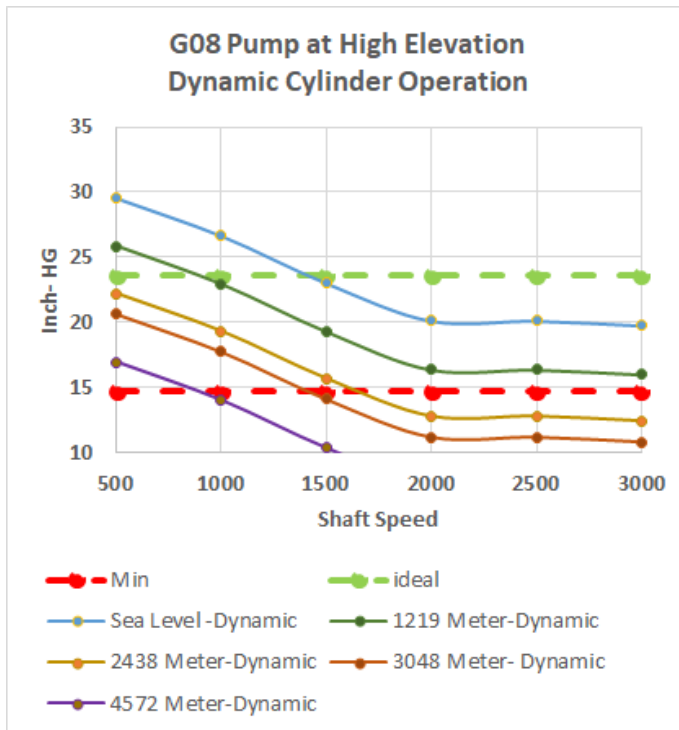
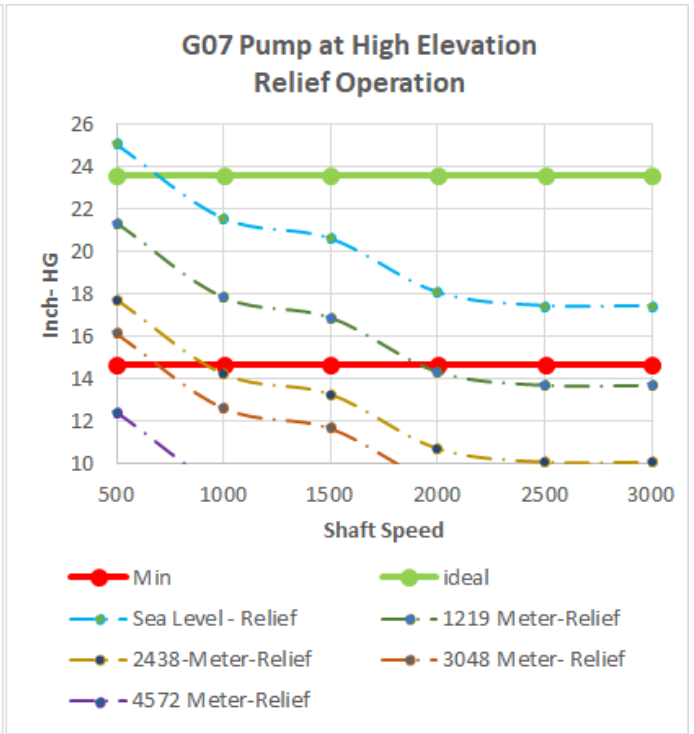
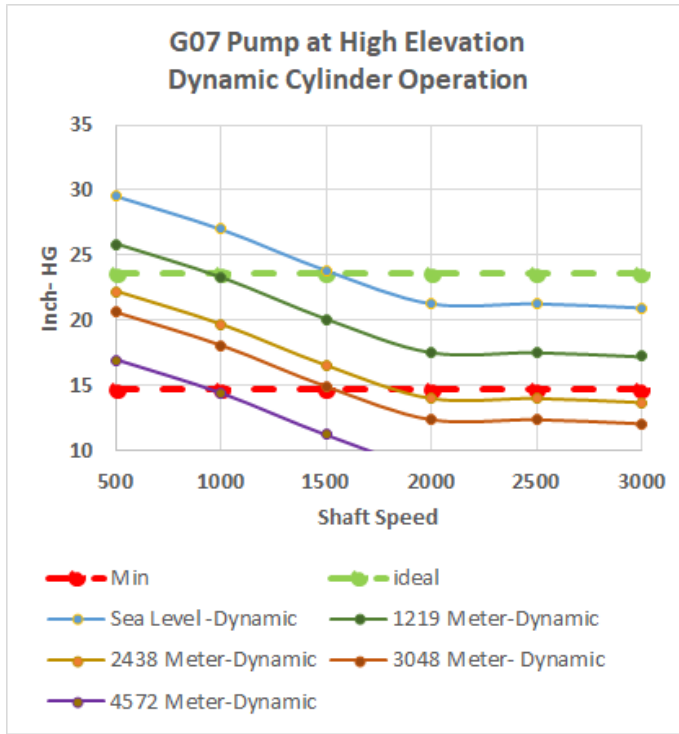

**WARNING:** This product can expose you to chemicals including Lead and Lead Compounds which are known to the State of California to cause cancer and birth defects or other reproductive harm. For more information go to [www.P65Warnings.ca.gov](http://www.P65Warnings.ca.gov)



# Inlet vs Elevation Charts

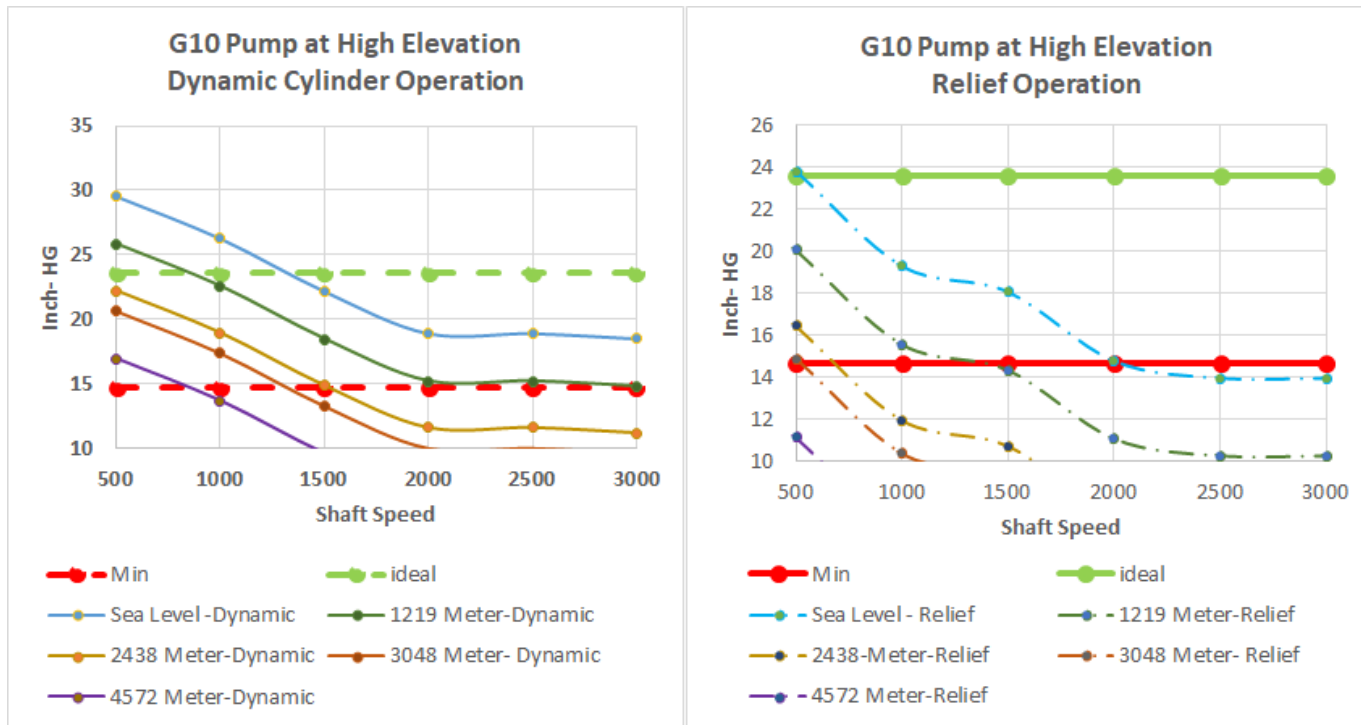
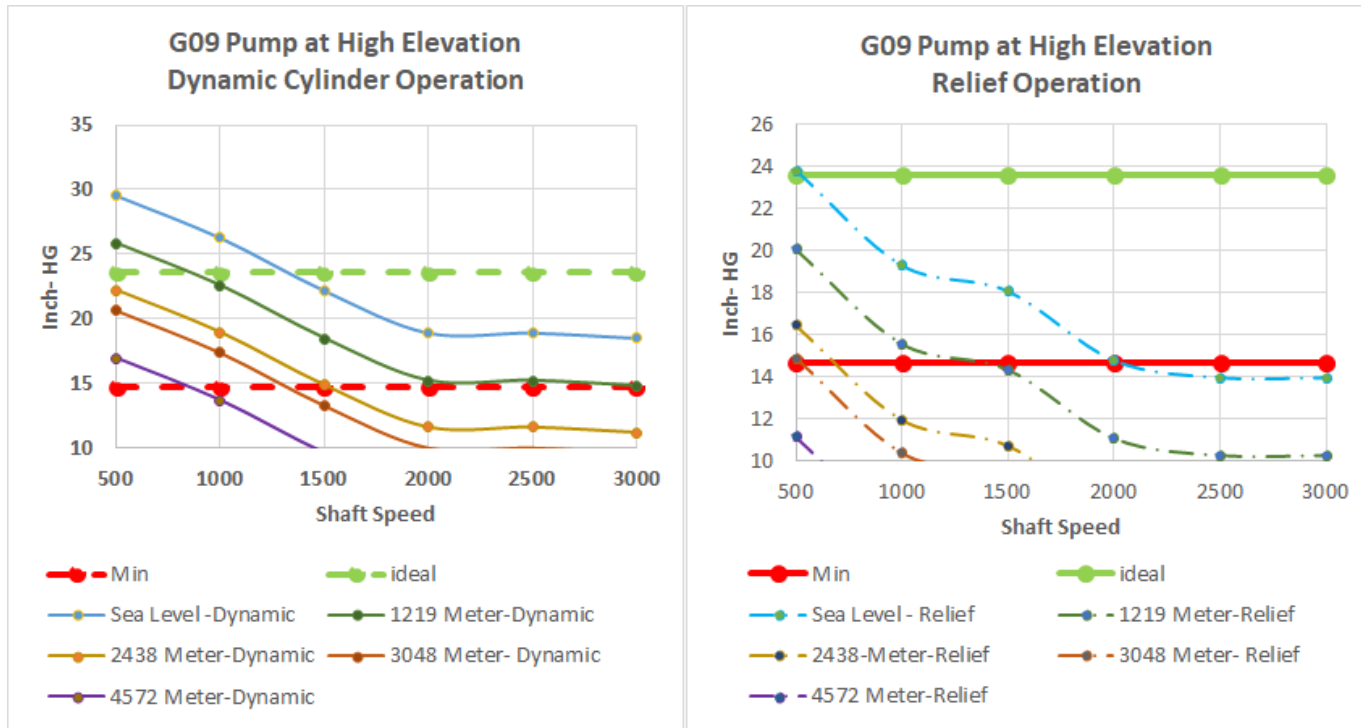

**⚠ PROP 65 WARNING** WARNING: This product can expose you to chemicals including Lead and Lead Compounds which are known to the State of California to cause cancer and birth defects or other reproductive harm. For more information go to [www.P65Warnings.ca.gov](http://www.P65Warnings.ca.gov)



# Valves and Adjustments

Pressure Relief HAS units offer individual over pressurization adjustments in both directions of operation, Push and Pull. The reliefs are factory set based upon the HAS Model Code. These valves should only be adjusted by trained individuals. Improperly adjustments can cause severe damage to the system, great care must be taken to ensure the system is not allowed to create pressures greater than the system is rated for.



Maximum pressures should NEVER exceed 3300 PSI relief settings.

The relief settings should never be used to limit the dynamic thrust of the HAS system. They should be set approximately 300 PSI above the dynamic operating pressure of the system. Settings closer to operating pressures will cause excessive heat in the hydraulic system and will cause premature failure to the HAS unit. A suitable rated pressure gauge should be installed on the appropriate “PA” or “PB” connection when adjusting the relief pressure.

If required to limit or stall on an over thrust condition, This should be achieved by limiting the motors torque. When the resistance to motion exceeds, this value, the HAS system will stall, and “hold” that thrust value based upon an amp limit in the motor. This is not suitable for a Force Control method, rather a force limiting control scheme. See Programmed Drives manual for more details on determining limits. For Force Control Schemes, see the Force Control Section of this manual.

Pressure Relief Adjustments		
Series	Maximum Valve	Minimum Valve
	Settings	Settings
HAS 500	5000 PSI	1000 PSI
HAS ST	3200 PSI	1000 PSI



5000 PSI Gauge

PD Coupler Part No: PD242

**⚠ PROP 65 WARNING** **WARNING:** This product can expose you to chemicals including Lead and Lead Compounds which are known to the State of California to cause cancer and birth defects or other reproductive harm. For more information go to [www.P65Warnings.ca.gov](http://www.P65Warnings.ca.gov)

# Pressure Relief Locations

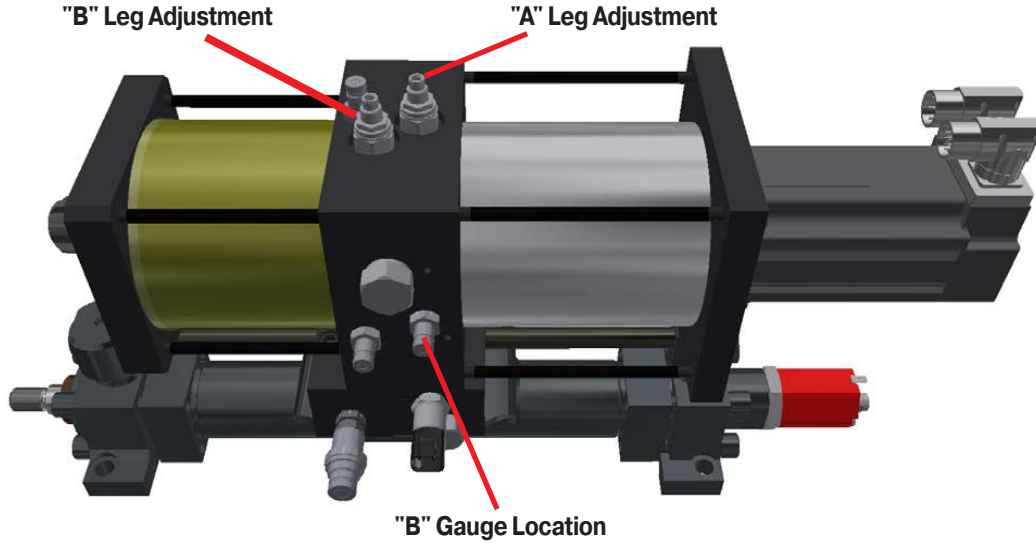

HAS 500 Over Pressure Relief locations

HAS 500 pressure "A" leg relief valves are always closest to the Electric Motor, while "B" are next to Reservoir. "A" gauge port is located on Opposite side and is stamped with "Pa".

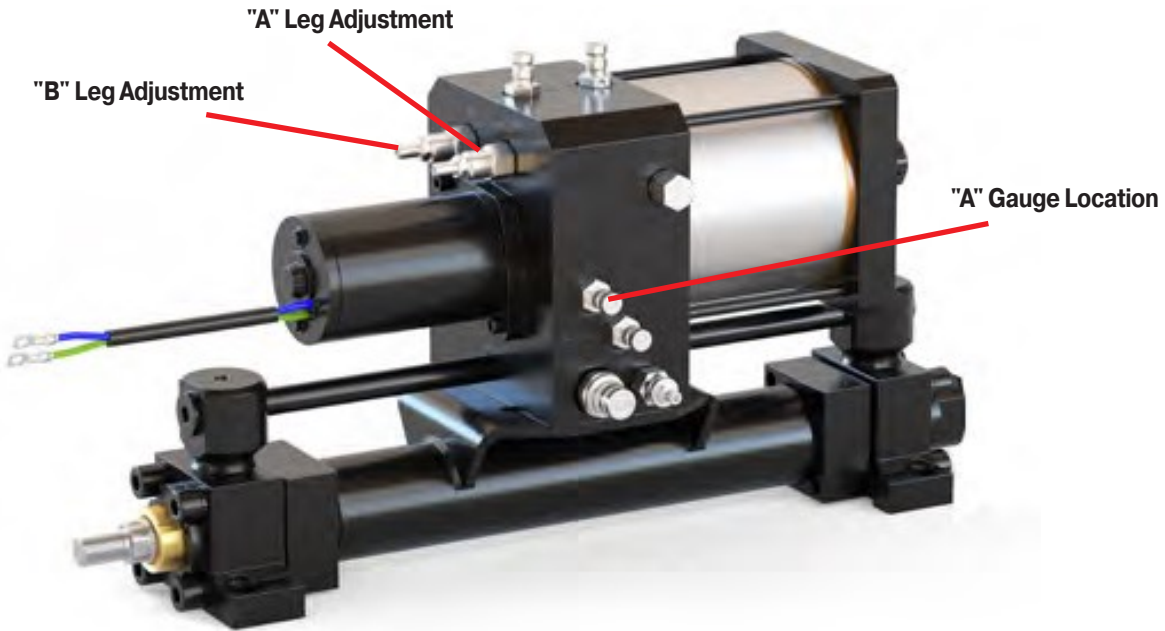

HAS ST Over Pressure Relief locations

**PROP 65 WARNING** **WARNING:** This product can expose you to chemicals including Lead and Lead Compounds which are known to the State of California to cause cancer and birth defects or other reproductive harm. For more information go to [www.P65Warnings.ca.gov](http://www.P65Warnings.ca.gov)

# Load Holding Valves - Counterbalance

## Load Holding

HAS units offer various combinations of load hold valves. The HAS Model Code indicates they type of valve and location in cylinder circuit. These valves are factory set and typically do not need adjustments.



**These valves should only be adjusted by trained individuals. Improperly adjustments can cause severe harm to equipment and to individuals near equipment. Observe all safety regulations and requirements regarding operation of the machine and associated device.**

Load Holding Valves will trap pressure in the Cylinder body and must be handled very carefully. Do not remove Load Holding valves from the HAS Unit while the HAS unit is in service or until all internal pressures have been relieved from the unit. Load Holding valve located in the “push” circuit, will prevent the cylinder from retracting by an overrunning load condition. Load Holding valve in the “pull” circuit will prevent the cylinder rod from extending by an overrunning load condition. Counterbalance Cartridge Valves: Three port counterbalance cartridges (with pilot-to open assist) are modulating devices that allow free flow from port 2 (inlet) to port 1(load) and then block reverse flow until a pilot pressure inversely proportional to the load pressure is applied at port 3 (pilot). The modulation of a counterbalance valve is a function of both the load pressure and the pilot pressure, yielding an “inverse pilot ratio”; light loads require more pilot pressure and heavy loads less pilot pressure to open the counterbalance valve, helping to improve stability and providing fine motion control. Counterbalance valves control motion by maintaining the high pressure leg of the HAS circuit always sees a positive load pressure, even with overrunning loads. Counterbalance valves will shut off with very low approaching zero leakage. They also incorporate a relief function from port 1 (load) to port 2 (inlet) which provides protection from load and/or thermal over pressure.

## Sizing

The setting of a counterbalance valve should be equal to at least 1.3 times the load pressure (1.5 times setting with valve set less than 2000 psi (140 bar)). Pressure required to lower load can be calculated from these equations. The pressure must be positive and optimally greater than 250 PSI.

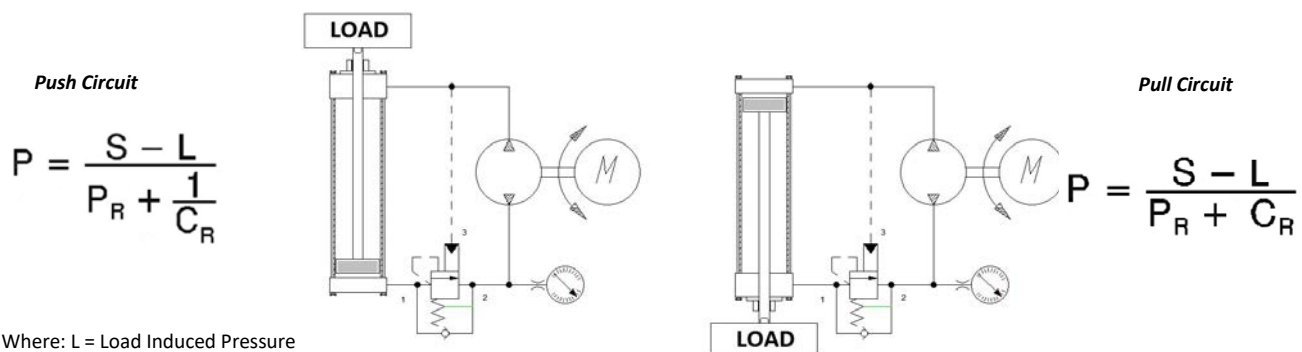

Where: L = Load Induced Pressure

P = Pilot Pressure Required to Open Valve

PR = Pilot Ratio (e.g. 3:1 = 3)

S = Relief Setting of Valve

CR = Cylinder Area Ratio =  $\left( \frac{\text{Bore Dia}^2}{\text{Bore Dia}^2 - \text{Rod Dia}^2} \right)$

**⚠ PROP 65 WARNING** **WARNING:** This product can expose you to chemicals including Lead and Lead Compounds which are known to the State of California to cause cancer and birth defects or other reproductive harm. For more information go to [www.P65Warnings.ca.gov](http://www.P65Warnings.ca.gov)

# Load Holding Valves - Counterbalance

## Circuit Order Code “C” Counterbalance Valves



Load Must be removed from HAS unit while adjusting Counterbalance Valves. Lowering the setting (Clockwise) rotation can allow load to drop, uncontrollably.

## HAS 500 Valves

Manufacture Specs: CBCA-LAN

Cavity T-11A, Capacity 15 GPM Check Cracking Pressure 4 PSI

Pilot Ratio 3:1

\*Factory Setting 3000 PSI

Recommended setting 1.3 X load PSI

Maximum Recommended Load Pressure at Maximum Setting 3075 PSI Adjustment Range: 1000-4000 PSI

Maximum Valve Leakage at Reseat 5 drops/min.

Reseat >85% of setting



Turn adjustment clockwise to decrease setting and release load.

Full clockwise setting is less than 200 psi (14 bar)

Adjustment - No. of CCW Turns from Min. to Max. Setting 3.75-4 Turns. Approximately 1275 PSI per turn

## HAS ST Counterbalance Valve

Manufacture Specs: Oder Code: “C” 55T163-3-3000 Order code “D” 55T163-10-4000

Cavity T-163A, Capacity 5 GPM Check Cracking Pressure 25 PSI

Order code “C” Pilot Ratio 3:1, Order code “D” Pilot Ratio 10:1

\*Factory Setting Order code “C” = 3000 PSI, Order code “D” = 4000 PSI Recommended setting 1.3 X load PSI

Maximum Recommended Load Pressure at Maximum Setting 3075 PSI

Adjustment Range: 500-5000 PSI

Maximum Valve Leakage at Reseat 5 drops/min.



Turn adjustment counterclockwise to decrease setting and release load.

Full counterclockwise setting is 500 PSI

Adjustment - approximately 1800 PSI per turn

\*Custom Settings available check with factory if “X” code in model call out.



### PROP 65 WARNING

**WARNING:** This product can expose you to chemicals including Lead and Lead Compounds which are known to the State of California to cause cancer and birth defects or other reproductive harm. For more information go to [www.P65Warnings.ca.gov](http://www.P65Warnings.ca.gov)

## Load Holding Valves - Counterbalance

### Emergency Setting of Counterbalance Valves when installed on a HAS

1. Observe all safety requirements regarding the operation of the machine and associated device.
2. Ensure that you are in control of the hydraulic support for the equipment and that no unanticipated hazardous machine movements can occur.
3. Make note of any “pinch points” and make sure any machine movement that occurs during the adjustment phase will not cause injury. Note, especially, the location of the counterbalance valve adjustment as it relates to this movement.
4. To increase the setting the rotation adjustment is counterclockwise on HAS 500 and counterclockwise on HAS-ST and setting will not be exact due to circuit interactions and the manner in which the valve is adjusted
5. Install a hydraulic system pressure gauge, in the appropriate port on the HAS upper manifold. Ports Labeled “PA” and “PB” should be used. To determine which port is required, locate the flow tube connection to the lower manifold for the desired Push/Pull circuit you wish to adjust. It will be Labeled either A or B based upon the orientation specified in the HAS Model Code. The corresponding letter is in the “P\*” test port connection is where pressure can be measured.
6. Start with the counterbalance valve at the standard factory setting, listed in above Manufacturer specifications for your HAS series
7. Set up the machine with the maximum load on the actuator that is being supported by the counterbalance valve. (If the actuator causes angular motion, make sure the actuator is in the maximum load position.) Slightly and slowly (with minimum speed command to HAS) raise the load.
8. Observe the gauge and record the maximum pressure generated when raising the load.
9. From the above manufacturer specifications for your HAS series, verify the amount of psi per turn corresponding to your model valve. HAS500 1275 PSI/Turn, HAS-ST 1800 PSI/Turn.
10. Multiply the observed load pressure by 1.3 for pressure readings greater than 2000 PSI and 1.5 time for pressures less than 2000 PSI.
11. Readjust the counterbalance valve to the calculated pressure. For HAS500 by either increasing (turning counterclockwise) or decreasing (turning clockwise) to vary the setting. For HAS-ST by either increasing (turning clockwise) or decreasing (turning counterclockwise) to vary the setting.

### Example

1. Maximum gauge (load) pressure observed when slowly raising (moving) the load at maximum load point = 2600 PSI.
2. Multiplying load pressure by 1.3 ( $1.3 \times 2600$ ) = 3380 psi (233 bar). This is the recommended counterbalance valve setting for this application.
3. We have a HAS 500 and from Specifications, CBCA-LAN has an adjustment rate of 1275 psi (89 bar) per turn. Subtract the factory setting from the gauge reading and divide the total by the adjustment rate of the table.  $3380 - 3000 = + 0.3$  turns (counterclockwise) 1275 (For reference, if the maximum load pressure happens to be lower than the factory setting, the calculation will yield a negative number of turns (clockwise).
4. Adjust the counterbalance valve as calculated above by loosening the lock nut and turning the adjust screw (approximately 1/3 turn or 2 wrench flats) counterclockwise on the adjust screw in the above example.
5. Retighten the locknut to the specified torque, being careful not to turn the adjustment screw.

 **PROP 65 WARNING** **WARNING:** This product can expose you to chemicals including Lead and Lead Compounds which are known to the State of California to cause cancer and birth defects or other reproductive harm. For more information go to [www.P65Warnings.ca.gov](http://www.P65Warnings.ca.gov)

# Load Holding Valves - PO Check Valves

## Pilot To Open Check Valves

The port pilot-to-open check valve cartridges are non-modulating, on/off devices that allow free flow from port 2 (inlet) to port 1 (load) and block reverse flow until a pilot pressure directly proportional to the load pressure is applied at port 3 (pilot) to allow the pilot piston to push the check poppet off its seat and allow flow from port 1 to port 2.

It is a load holding valve, not a load lowering valve. When trying to lower a load, severe machine “ratcheting” may result.



Pilot-to-open check valves should be used on horizontal applications with no overrunning load implications where you wish to hold the HAS actuator position when off.

Pressure required to open check

*Push Circuit*

*Pull Circuit*

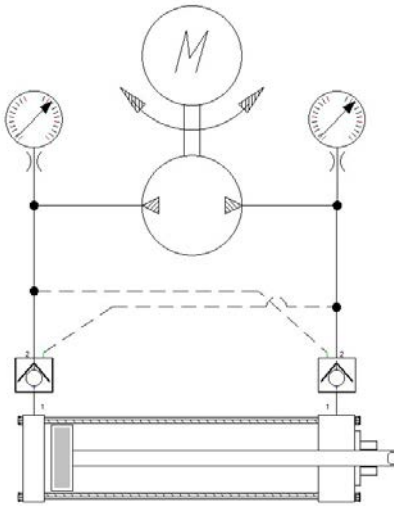

$$P = \frac{S - L}{P_R + \frac{1}{C_R}}$$

$$P = \frac{S - L}{P_R + C_R}$$

Where: L = Load Induced Pressure

P = Pilot Pressure Required to Open Valve

PR = Pilot Ratio (e.g. 3:1 = 3)

S = Relief Setting of Valve

CR = Cylinder Area Ratio =  $\left( \frac{\text{Bore Dia}^2}{\text{Bore Dia}^2 - \text{Rod Dia}^2} \right)$

**⚠ PROP 65 WARNING** **WARNING:** This product can expose you to chemicals including Lead and Lead Compounds which are known to the State of California to cause cancer and birth defects or other reproductive harm. For more information go to [www.P65Warnings.ca.gov](http://www.P65Warnings.ca.gov)

# Load Holding Valves - PO Check Valves

## Circuit Order Code “P” and “R” Pilot Operated Check Valves

### HAS 500 PO Check Valves

Manufacture Specs: Code: Order Code: “P” CKCB-XAN Code “R” = CKCB-LAN  
Cavity T-11A, Capacity 15 GPM Check Cracking Pressure 4 PSI

Pilot Ratio 3:1

Maximum Valve Leakage 1 drops/min.

### HAS-ST PO Check Valves

Manufacture Specs: Code: Order Code: “P” CKBD-XCN , Code: “R” CKBD-LCN

Cavity T-163A, Capacity 7.5 GPM Check Cracking Pressure 30 PSI

Pilot Ratio 3:1

Maximum Valve Leakage 1 drops/min.

Circuit Cide: “N” is for No load holding, we supply a “R” coded PO check Valve, with manual override engaged. This allows for Free flow in either direction.

If override poses potential application issues a Tamper Resistant cover is available.

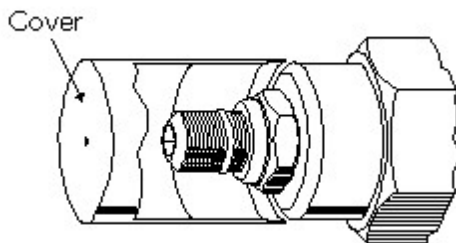

Sun Part Number: 991000

**⚠ PROP 65 WARNING** **WARNING:** This product can expose you to chemicals including Lead and Lead Compounds which are known to the State of California to cause cancer and birth defects or other reproductive harm. For more information go to [www.P65Warnings.ca.gov](http://www.P65Warnings.ca.gov)

# Load Holding Valves - Locations on Lower Manifold

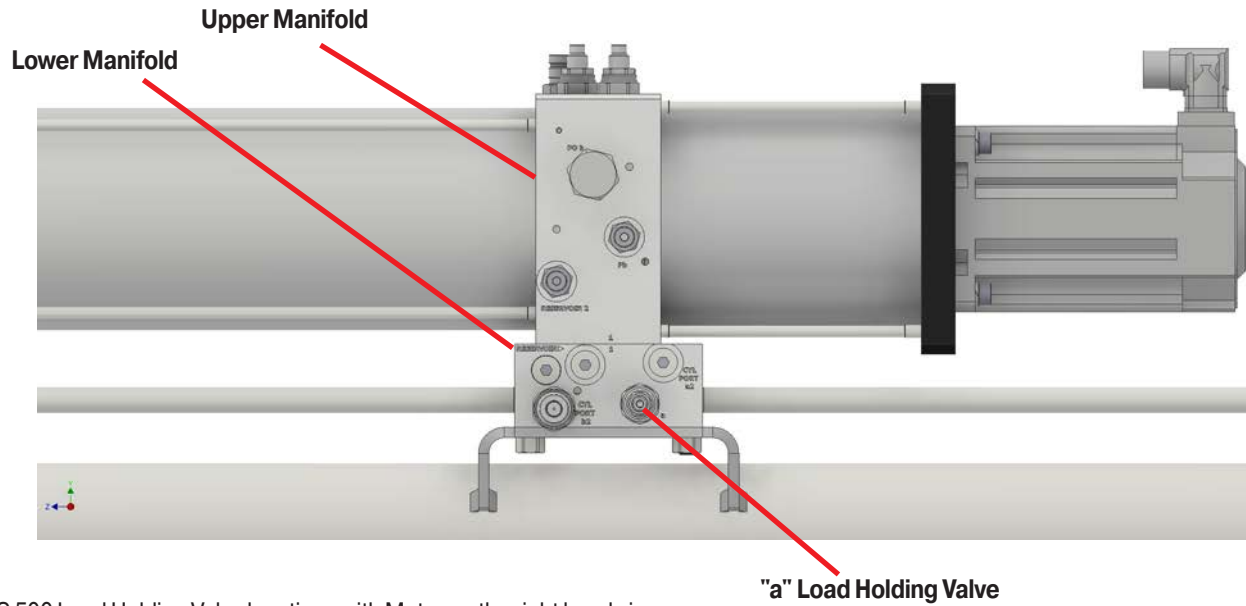

HAS 500 Load Holding Valve locations with Motor on the right hand size.

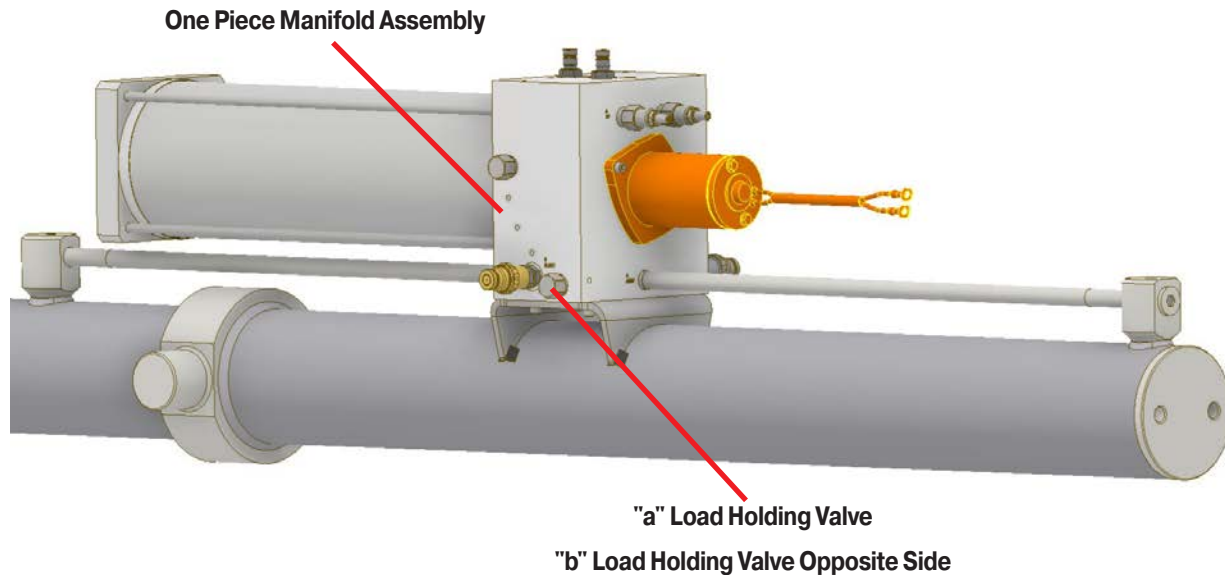

HAS ST Load Holding Valve locations with Motor on the right hand size.

Load holding valves are located in the lower manifold and stamped “a” and “b”. The “a” port is always located on the motor side of the upper manifold, “b” located on the reservoir side. Based upon orientation ordering dictates which valve is Push Circuit and Pull Circuit. Use below table to determine Valve location.

Load Holding Valve Locations				
Orientation	A	B	C	D
Push Circuit	b	s	s	b
Pull Circuit	a	b	b	a

**⚠ PROP 65 WARNING** **WARNING:** This product can expose you to chemicals including Lead and Lead Compounds which are known to the State of California to cause cancer and birth defects or other reproductive harm. For more information go to [www.P65Warnings.ca.gov](http://www.P65Warnings.ca.gov)

# Low Oil Level Sensor

## Reservoir Level

Both HAS 500 and HAS-ST reservoir bladders are equipped with rare earth magnet for sensing low oil reservoir levels.

Reservoir housings are offered in either aluminum or composite material, held together with tie rods. This allows the use of tie rod mounted reed switches to detect low reservoir oil condition.

Reservoir volume is sized for 2.5 times the amount of fluid exchanged in the cylinder. The magnet will be in the switch zone when volume is depleted, and service should be performed, as oil levels are extremely low.

Magnet placement on the bladder is clocked based upon seam location, with the seam at 12:00 o'clock, magnet location will be on the lower tie rod on left side. The Switch Trip zone can be determined by measuring 5.5" from the upper manifold away from the motor end. Switch zone must use lower tie rod for switch placement.

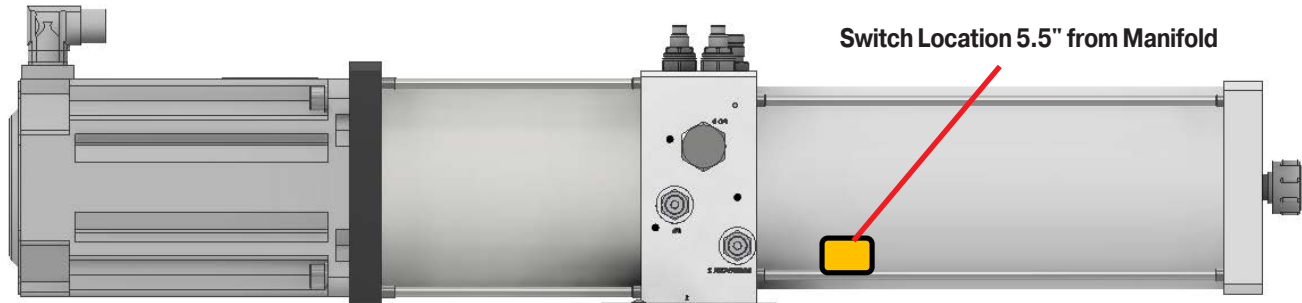

Part Number	Description
P8SAGRCHX	Reed-NO, with LED, 2-wire, 0.3 Meter Cable
P8SAGRFAX	Reed-NO, with LED, 2-wire, 3 Meter Flying Lead
P8SAGRFTX1	Reed-NO, with LED, 2-wire, 10 Meter Flying Lead
086620T005	8 mm Cable, 5 Meter
086620T002	8 mm Cable, 2 Meter

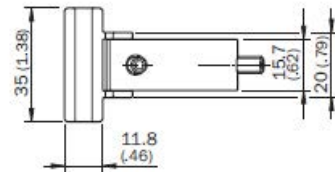
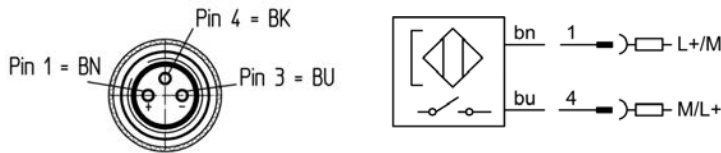
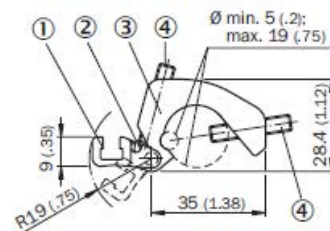

For units shipped before October 2023, please contact factory for switch location

- ① Sensor adapter with T-Slot
- ② Fixing for cable < Ø 3.2 mm (0.126 inch)
- ③ Cylinder adapter
- ④ Mounting screws M5

**⚠ PROP 65 WARNING** **WARNING:** This product can expose you to chemicals including Lead and Lead Compounds which are known to the State of California to cause cancer and birth defects or other reproductive harm. For more information go to [www.P65Warnings.ca.gov](http://www.P65Warnings.ca.gov)

# Motor "A" Series Industrial



High Voltage – risk of personnel injury and or damage to equipment

HAS "A" series and "D" series motors contain permanent magnets and will act as a generator if back driven. This will create a voltage between the power terminals, which is proportional to the speed of the motor. This is independent of whether the motor is connected to an inverter/drive or not.

If runaway loads conditions are possible, it is strongly recommended to order HAS units with counterbalance style valves to prevent the HAS motors to be back driven.

**A Series** Motors utilize series connectors featuring TE Connectivity Interconnection circular connectors mounted to the motor body. These connectors are right angle mount and can be fully rotated 360 degrees allowing for greater cable routing options. Mating cable assemblies can be ordered separately or included in the A series Drive Kits. The connections are split into two connectors one for Motor Power (Phases and Brake) and one for Feedback (Resolver and Thermistor) The second connector has the motor feedback with the thermistor signals.

These motors are not field serviceable, they must be returned to the factor for service.

Connections: IP66/IP67 protection ratings according to EN 60529

**Power Connector**

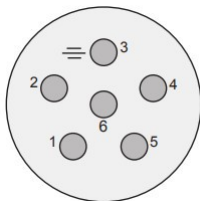

**Feedback Connector**

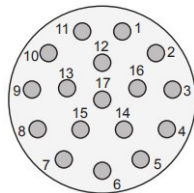

Designation	Pin Number
Phase A	1
Phase B	2
Phase C	3
Ground	3
Shield	3
**Brake	4
**Brake	5

Designation	Pin Number
Ref Sin	1
Sin +	2
Data +	5
Data -	6
Temp +	9
Cos +	11
Ref Cos	12
Temp	13
+5V	14
Grd	17

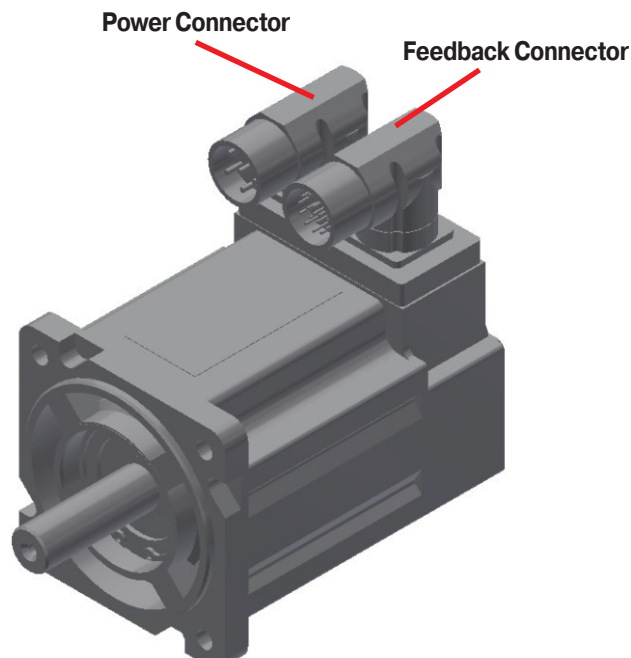

\*\* HAS Motor are not provided with Brakes, use Counterbalance valves to prevent runaway loads.

**PROP 65 WARNING** **WARNING:** This product can expose you to chemicals including Lead and Lead Compounds which are known to the State of California to cause cancer and birth defects or other reproductive harm. For more information go to [www.P65Warnings.ca.gov](http://www.P65Warnings.ca.gov)

# Motors - A Series Connectors and Technical Data

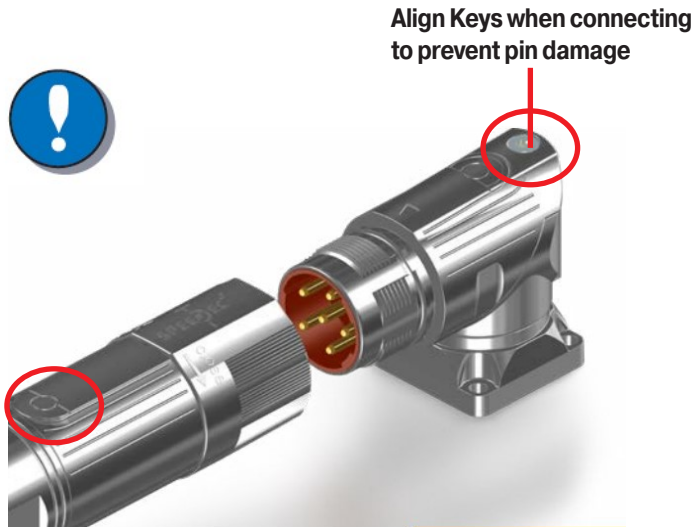

Motor Connector Data	
Housing	Nickel-plated Zinc
Coupling Nut	Nickel-plated Zinc
Insulation Insert	PBT UL94/VO
Contacts	Gold Plated Brass
Sealing	FKM Viton Fluoro-carbon Rubber
Clamp Ring	Nickel-plated Zinc
Temperature Range	Standard: -4 to 266 F
Rotation Angle	330 degrees
Mating Cycles	500

A09* and A10* Motor Power Connector	
Motor Connector	Intercontec BEDC106MR14001216000
Mating Connector Kit*	PS-CONN-KIT
A11* and A14* Motor Power Connector	
Motor Connector	Intercontec BEDC106MR43001216000
Mating Connector Kit*	PS-CONN-KIT
A Series Motor Feedback Cable	
Motor Connector	Intercontec AEDC139MR04001215000
Mating Connector Kit*	PS-CONN-KIT

Motor Power Cable		
Cable No	Drive Kit Number	Motor Series
P-3B1-xxx	0991760 **1	A09* ~ A10*
P-4B1-xxx	0991760 **2	A10* ~ A14*

Motor Power Cable							
Cable No	Connector	Amps	Jacket	Size Wire	Temp	Bend Radius	Diameter
P-3B1-xxx	BSTA08FR2355	20	PVC	14 AWG	14-221° F	4.45"	0.445
P-4B1-xxx	BSTA08FR2355	30	PVC	12 AWG	14-221° F	4.7"	0.47

Feedback Cable							
Cable No	Connector	2nd End	Jacket	Size Wire	Temp	Bend Radius	Diameter
F-2B1-xxx	ASTA035FR0162	HDP-22 (Compax)	PVC	24 AWG	14-221° F	3.4	3.4
F-9F1-xxx	ASTA035FR0162	Flying Leads	PVC	24 AWG	14-221° F	3.4	3.4

**⚠ PROP 65 WARNING** **WARNING:** This product can expose you to chemicals including Lead and Lead Compounds which are known to the State of California to cause cancer and birth defects or other reproductive harm. For more information go to [www.P65Warnings.ca.gov](http://www.P65Warnings.ca.gov)

# Motors "D" Series (Mobile)

"D" series Motors are a PMAC (permanent magnet, alternating current) type and require a three phase AC inverter that can accept sinusoidal feedback.

It is recommended to use matching inverter Part Number: 099170XXXX\* for proper operation.

HAS "D" series motors are designed for operation in Harsh environments, they have been tested and meet IP56 ingress protection.

Motor is designed to operate with limited field weakening and typical range is 1.5 X base motor speed. Field weakening is enable with matching inverter part number: 009170\*\*\*\*. Motor is non-serviceable and must be returned to factory for repair.

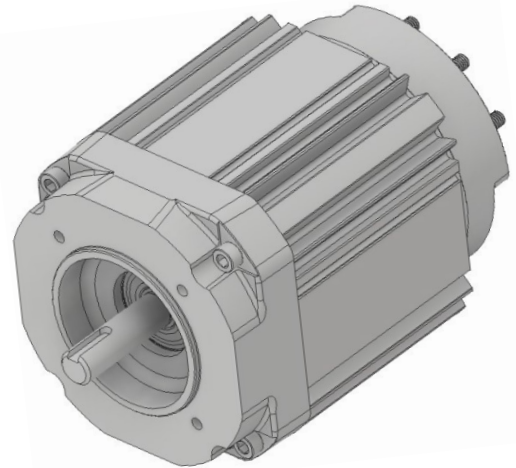

Recommended periodic inspection of the motor to minimize significant dirt build up on the motor. Build up can reduce cooling of the motor which reduces performance of the HAS assembly. The motor and HAS unit can be cleaned with a damp cloth with a mild degreaser.



Do Not clean the motor or controller with high pressure water

Hot Surfaces- risk of personal injury after operation, the motor maybe too hot to touch, allow it to cool before performing any maintenance.

Connections Power terminal connection are M6 x 1.0 studs, hardware is not included with motor.

**Recommended connections**  
**M6 Nylon Locking Nut with Lock Washer and Flat washer.**

**Terminal Cover Boot cover is strongly recommended**

**Feedback Connector**  
**8-Pin AMP SEAL**  
**Mating: 776286-1**  
**Pin: 770854**

**Power Connection**  
**(3) M6x1 studs for U/V/W**  
**(4) connections**

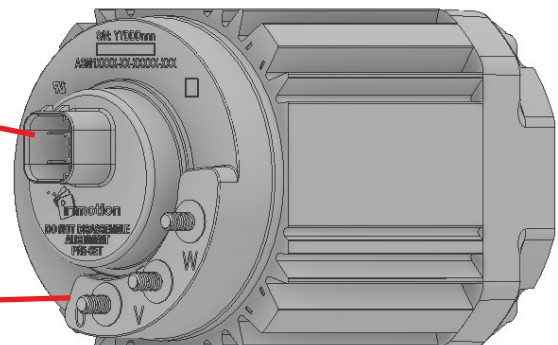
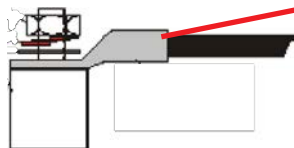

**⚠ PROP 65 WARNING** **WARNING:** This product can expose you to chemicals including Lead and Lead Compounds which are known to the State of California to cause cancer and birth defects or other reproductive harm. For more information go to [www.P65Warnings.ca.gov](http://www.P65Warnings.ca.gov)

# Motors "D" Series Cable Sizing

## UV and W Cables

To avoid burning or overheating of the high-current terminals, ensure the cable connection has been made to handle the rated current of the motor and correct torque has been applied to the M6 nuts.

Proper torque: 9.0 ~ 9.2 nM.

Washer used between cable lug and terminal must be made of copper to prevent overheating

Motor and Battery Cables must be thermally dimensioned to match the power motor controller and motor. The European standard EN1175-1 (A3.7) requires the battery connector parts withstand 90C. It is recommended at a minimum all cables chosen meet this requirement. Cable area shall be selected to match the 1-hour rating of the application. European standard EN1175-1 (5.10.2) As a rule of thumb use the current density of 3 A mm<sup>2</sup> to determine cable area.

$$\frac{X \text{ (1 Hour Amps)}}{3 \text{ (A/mm}^2\text{)}} = \text{Cable Area (mm}^2\text{)}$$

Motor Code	D03	D06	D09	D12
Power (W) S2 60 min	630	1200	1475	1850

Connections Feedback Integral Molded 8 Pin AMP Seal Connector. Mating Connector not included with motor. Should be ordered separately or with Drive Kit.

## Feedback Cables

Avoid free hanging signal wires, recommended wire gauge range 16-20 AWG. Physically separate the feedback cable from the Power Cables (U, V,W). Recommended separation is 4" (100 mm).

D Series FB Connections	
Designation	Pin Number
Not Used	1
Not Used	2
Supply Grd	3
Thermistor Ground	4
Thermistor Sense	5
Cosine Out	6
Sine Out	7
Supply Voltage (11V)	8

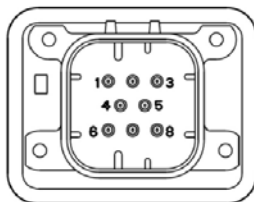

Feedback Mating Connector

Part Number: 0991740000

AMP Seal No: 776286-1



Sockets – Crimp 16~20 AWG

Part Number: 0991750000

AMP Seal No: 770854-1

**⚠ PROP 65 WARNING** **WARNING:** This product can expose you to chemicals including Lead and Lead Compounds which are known to the State of California to cause cancer and birth defects or other reproductive harm. For more information go to [www.P65Warnings.ca.gov](http://www.P65Warnings.ca.gov)

# Motor Over Temperature Sensors

## Motor Over Temperature Sensors

A series Motors , Model Code Configuration A\*\*\* use a PTC thermistor that acts a switch. Its designed to connect to the motor therm connection on the 0991760\*\*\*-\*\*\_\*\*\* drive kits to provide thermal protection on the motor. The connection is located in the Feedback Connector, wire colors Gray and Pink. Nominal Reaction temperature 70 C to 180 C. See either Ethernet or Analog service manuals for connection details.

Operating Voltage Range: 2.5 VDC to 24 VDC

Max permissible operating voltage: 30 VDC

Max recommended sensor voltage: 2.5 V DC to 7.5 VDC

D series Motors, Model Code D\*\*\* use a platinum resistance thermometer (PT 1000), designed specifically for use with drive kits 009170\*\*\*-D\*\* and provide thermal protection of the motor. The linear cutback on current starts at 158 °C with 100% cutback at 170 °C.

See D series Drive Manual for connection details.

**PROP 65 WARNING**

**WARNING:** This product can expose you to chemicals including Lead and Lead Compounds which are known to the State of California to cause cancer and birth defects or other reproductive harm. For more information go to [www.P65Warnings.ca.gov](http://www.P65Warnings.ca.gov)



# Pressure Transducers

## Pressure Sensors

In the Options call out of the HAS 500 model code, you may select to have the HAS unit fitted with pressure measuring transducers. Two selections types for transducers, Industrial and Mobile. They are categorized based upon output and connector styles. Since HAS units operate hydrostatically, a pressure transducer is provided in both the cap end (push) and head end (pull) areas of the cylinder. Force measurement can be determined by the following equations:

$$\text{HAS Force (lbs)} = \text{Push Force (-) Pull Force}$$

$$\text{Push Force} = \text{Measured Value} \times \text{Push Force Scale}$$

$$\text{Pull Force} = \text{Measured Value} \times \text{Pull Force Scale}$$

$$\text{*Push Force Scale} = (\text{Cap Area} \times \text{Sensor Max PSI}) / \text{Voltage output}$$

$$\text{*Pull Force Scale} = (\text{Head Area} \times \text{Sensor Max}) / \text{Voltage output}$$

$$\text{Cap Area} = (\text{Bore Diameter}^2 \times \text{PI}) / 4$$

$$\text{Head Area} = \text{Cap Area (-) Rod Area}$$

$$\text{Rod Area} = (\text{Rod Diameter}^2 \times \text{PI}) / 4$$

## Industrial Pressure Sensors

Industrial sensors are equipped with an industrial standard M12 4 pin connector providing IP67 protection. Supply Voltage of 12-30 VDC. Units produce full scale, 0 to 10V output at 0 to 250 bar (3625 PSI) measurements.

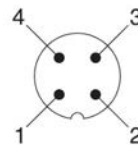

Over load pressure of 10,000 PSI. Response time of less than 1 millisecond and accuracy of 0.5% full scale measurement.

Pin	Description	Wire Color
1	Vs (Supply Voltage)	Brown
2	Output (0-10V)	White
3	Vc (Common)	Blue
4	N/C	

## Mobile Pressure Sensors

Mobile sensors are equipped with Deutsch DT series connector providing IP67 protection. Supply Voltage of 5 VDC required. Units produce 0.5 to 4.5 V output for "0" to 3625 PSI measurements



Over load pressure of 7,250 PSI. Response time of less than 1 millisecond and accuracy of 0.5% full scale measurement. When calculating Force using Mobile sensors, you must subtract the minimum voltage (0.5v) proportion from your force calculation.

Pin	Description
1	Output 0.5-4.5 V
2	Vs (Supply Voltage)
3	Vc (Common)
4	N/C

**PROP 65 WARNING** **WARNING:** This product can expose you to chemicals including Lead and Lead Compounds which are known to the State of California to cause cancer and birth defects or other reproductive harm. For more information go to [www.P65Warnings.ca.gov](http://www.P65Warnings.ca.gov)

## Maintenance

Hybrid Actuation Systems (HAS) require little to no maintenance. The pump is broken in prior to assembly to minimize self-generated contamination. The fluid and conveyance system is a completely sealed system with a polyurethane membrane to act as a barrier from the system and the environment. This membrane allows for the fluid reservoir to breath as the cylinder exchanges fluid in the reservoir, while preventing unwanted contaminants from entering the system. The entire system is flushed clean to ISO 16/14/11 cleanliness standard and pre-filled prior to shipment.

When using Parker DuraClean you can expect over 8,000 hours of operation on a HAS500 before requiring an oil change. Operation durations of 5 years, a fluid sample from the system should be performed to ensure fluid integrity. HAS ST are designed for intermittent use, and fluid should be monitored for replacement on a periodic schedule.

It is a mechanical hydraulic system and periodic visual inspection should be performed to ensure operation. Visual inspection for external leaks, excessive temperature, and vibration should be performed on a routine schedule

### Cylinder and Power Pack Replacement Parts

Contact Parker Cylinder and Accumulator Division at (847) 298-2400 to obtain details on replacement parts for both the cylinder and power pack.

Please locate the CPN number (1H) Part number located on actuator label or engraved on Cylinder Head.

 **PROP 65 WARNING** **WARNING:** This product can expose you to chemicals including Lead and Lead Compounds which are known to the State of California to cause cancer and birth defects or other reproductive harm. For more information go to [www.P65Warnings.ca.gov](http://www.P65Warnings.ca.gov)

## Oil Sample Kits

The HAS system is vacuum sealed, and care must be taken to prevent loss of sealing. Fluid Sampling is an option to ensure the integrity of the HAS Units. It will provide detailed information of component wear and fluid life. Bottle samples should be limited to 3 samples before adding fluid to your HAS assembly.

Fluid sample kit consist of a (1) Par-test Oil sample Bottle and Shipping Box. Fill out the enclosed form and follow directions for a “systems with sampling valve”.

In order to take a fluid sample it is required to operate the HAS unit, forcing fluid through an orifice in the fluid sample port. It is preferred do sample fluid while HAS actuator is operating during normal cycle. If unit must be bottomed out in either direction for fluid sample, the Motor RPM should be limited to 10~15% (400 to 600 RPM) as not to create a lot of heat in the closed system.



Oil Sample Kit Part No 927292



With the HAS unit off or at rest, ensure a needle valve is used and is fully closed, connect the coupler to either the “PA” or “PB” port located on the upper manifold. Ensure it is safe to actuate HAS unit. Enable drive and activate HAS assembly a minimal speed (10 to 15% speed command). Open needle valve and allow a small amount, approximately 1/4 cup fluid to “flush” through the hose assembly into a waste container. Open the supplied wide mouth bottle, ensure no airborne or external contaminates are allowed to enter the bottle while sampling. Fill bottle approximately half to three quarter full of fluid. Do Not Fill Bottle more than 1” from top of Jar. Close sampling bottle immediately and disable HAS unit. Close needle valve and remove sampling device from HAS Unit. Insert the bottle in supplied plastic bag and insert in supplied card box. Use box as shipping container.

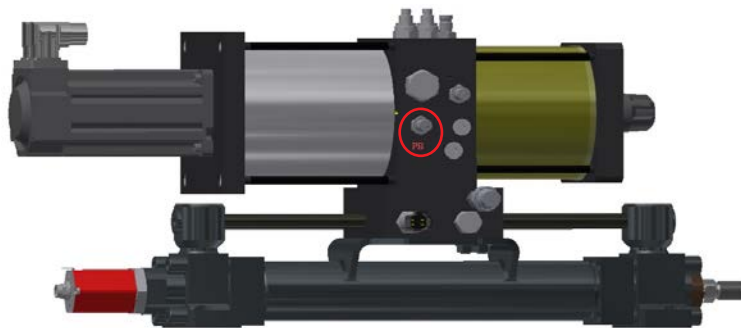

Fluid Sample Port Location on Upper Manifold assembly

Note: Clockwise rotation flow on PA port Counter Clock Wise rotation flow on PB port Fluid samples must be taken from the high pressure leg. The sampling connection **must have an integral check** valves, as not to allow air to be inadvertently added to the system if installed on the incorrect leg or spinning HAS unit in wrong direction. If no fluid is flowing through hose, with needle valve in open position, reverse direction or connect to opposite P\* port.

**Pumps**

# Pumps

## Gear Housings

Wear in excess of 0.005" cutout necessitates replacement of the body. Place a straight –edge across the bore, if you can slip a 0.005" feeler gauge under the straight edge in the cutout area, replace the pump assembly.

HAS PGP505 pumps are factory broken in and will need to be replaced as a set.

The HAS unit will need to be flushed and filled with new fluid for pump part replacements.

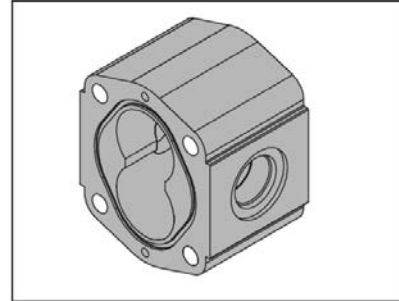

## Gears

Any scoring on gear hubs requires replacement. Scoring, grooving or burring of the outside diameter of teeth also requires replacement.

HAS PGP505 pumps are factory broken in and will need to be replaced as a set.

The HAS unit will need to be flushed and filled with new fluid for pump part replacements.



## Bushing Blocks

Bushing blocks seal the gear sections at the sides of the gears. Wear on bushing blocks will increase internal leakage and lower HAS speed capabilities. A maximum of 0.002" wear is allowable.

Pitted bushing blocks would indicate Cavitation or aeration, likely caused by over speed or low oil reservoir levels.

HAS PGP505 pumps are factory broken in and will need to be replaced as a set.

The HAS unit will need to be flushed and filled with new fluid for pump replacements.



**⚠ PROP 65 WARNING** **WARNING:** This product can expose you to chemicals including Lead and Lead Compounds which are known to the State of California to cause cancer and birth defects or other reproductive harm. For more information go to [www.P65Warnings.ca.gov](http://www.P65Warnings.ca.gov)

# Fluid Replacement

The HAS Reservoir is hermetically sealed from the outside environment. Reservoir capacity is oversized to allow for any rod seal weep. It is typically sized for 2.5 X the rod volume, assuming 80% fill capacity. If HAS unit's rod seal or other sealing device has failed causing oil pooling around machine, the HAS unit must be removed from operation and sent back to the factory for repair.

It is possible to drain the reservoir or add fluid to replace any losses from oil samples removed from the system, with commercially available parts. After 8000 hours of operation, the HAS assembly should be removed from service and returned the Parker Hannifin Cylinder division for a complete rebuild, including seal replacement.

## Draining Reservoir

Fluid may be removed from the reservoir with a commercially available Vacuum chamber. This vacuum system will also be used during filling.

You will need to add the appropriate coupler to the vacuum hoses for connection to the HAS Unit. HAS units are equipped with either a PD Nipple (Standard) or with the FF series on the Reservoir Fill Connection. Standard Fill / Drain connections are Parker PD quick disconnects, if equipped with either a Kidney Loop cooling system or Hand Pump accessories, the fill port connection is a FF series.

Drain the reservoir from the Low Point Tap– stamped “Reservoir 2”. Also required for all HAS units is a PD Mating coupler for proper draining.

See figure 3 for location.



Figure 1 Typical Oil Extraction System



Figure 2 Fill/Drain port couplers

Mating Couplers (NPT)	Part Number	Max Flow
PD Coupler - 1/4" NPT 71 Series Coupler-1/4" NPT / 71-3N6-4F/ 10 gpm	0993140042 (PD242)	0.5 GPM
FF Coupler - 1/4" NPT	FF-251-4MP	4 GPM

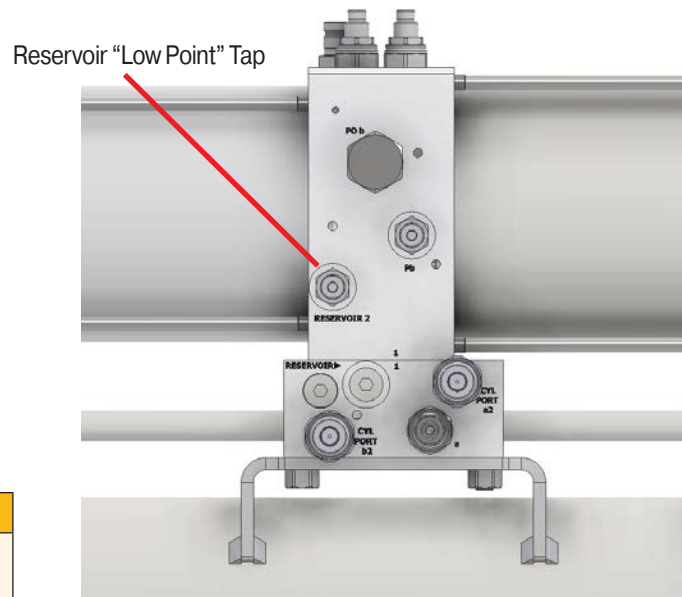

Figure 3 Fill/Drain port location

**PROP 65 WARNING** **WARNING:** This product can expose you to chemicals including Lead and Lead Compounds which are known to the State of California to cause cancer and birth defects or other reproductive harm. For more information go to [www.P65Warnings.ca.gov](http://www.P65Warnings.ca.gov)

# Fluid Replacement

Area must be clean and free of debris before servicing. It may be necessary to clean the exterior of the HAS assembly before performing this service.

Before draining the system, the HAS unit should be removed from operation and be in the **Full Retract position**. Begin draining the reservoir by connecting the Vacuum line to the “Low Point” connection tap.

Remove a small amount of fluid to relieve residual pressure on the reservoir. Attach the PD coupler, vented to atmosphere to the “High Point” tap to allow the fluid to be evacuated without damage to the bladder.

Pull a vacuum on the reservoir with oil extraction device until all fluid has been removed. Elevating the reservoir end up slightly will assist in removal of all fluid.

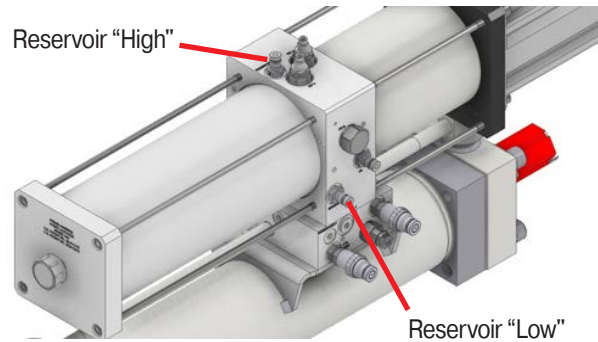

Figure 4 Reservoir Drain/Fill Couplers

## Filter Replacement

Once the fluid has been removed it may be desired to replace the filter element. Please contact your local Parker Distributor, with the CPN number of the actuator for a replacement Filtration Kit. The Filter Kit will include (2) O-rings (D), Reservoir Bladder (E) and replacement filter element (H). Disassembly of the reservoir is achieved by removing the Tie Rods (Item F) by loosening the Barrel Nuts (Item B) with a 5/16” Allen wrench. Loosen the barrel nuts in a crossing pattern as not to put too much stress on the opposing tie rods. Remove Reservoir End Cap, (item C), replace O-Ring seal in End Cap. Remove Reservoir Tube (item G) from upper manifold, the reservoir bladder can be discarded. Using a standard 2-1/2” oil filter removal tool, remove filter assembly (item H) from upper manifold.

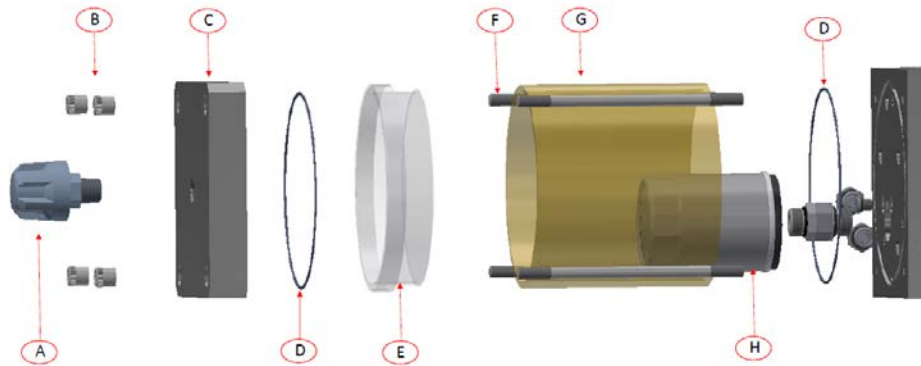

Figure 5 Reservoir exploded parts view

Item	Qty	Description	Part Number	Included in Filter Kit
A	1	Vent Plug	0983590000	No
B	4	Allen Nuts	0757650020	No
C	1	Reservoir End Plate	0983560500	No
D	2	End Seal	0477380070	Yes
E, F, G	N/A	CPN Specific	N/A	Yes
H	1	Filter	0988690000	Yes

**⚠ PROP 65 WARNING** **WARNING:** This product can expose you to chemicals including Lead and Lead Compounds which are known to the State of California to cause cancer and birth defects or other reproductive harm. For more information go to [www.P65Warnings.ca.gov](http://www.P65Warnings.ca.gov)

## Filter Replacement

Before assembly, ensure work space and all components are clean and free of debris.

Apply a small film of oil around Filter seal (H), and using the filter socket, re-install filter to upper manifold. Thread element on until seal comes in contact with Upper Manifold and turn 1/2 turn. Replace End seal (D) in Upper Manifold Groove Figure 6

The Bladders are cut to length based upon cylinder rod size and stroke length . Install the bladder on the reservoir tube by rolling the open end around the tube. You should have 1/2" of bladder exposed on the entire OD of the reservoir tube. Figure 7

Position Reservoir End Cap (item C) flat on table, if using the mounting holes, position in the proper position, with the "top" of the reservoir position facing away from you. Install O-ring seal (D) in reservoir End Cap. Figure 8

Locate the reservoir Bladder seam, and position seam at 12:00, facing you. This will orientate the magnet inline with the tie rods, for use with low oil switch detection. Press reservoir tube in groove. Figure 9

Ensure End Seal (D) is seated in Upper Manifold Groove, thread Tie Rods into Upper manifold. Slide Reservoir Tube with bladder and Reservoir Cap installed onto upper Manifold. Bladder seam must be located on Cylinder side of mounting. Figure 10

**Torque Allen Nuts to 13 Ft-Lbs in crisscross pattern.**

Bladder Seam at 12:00 Location

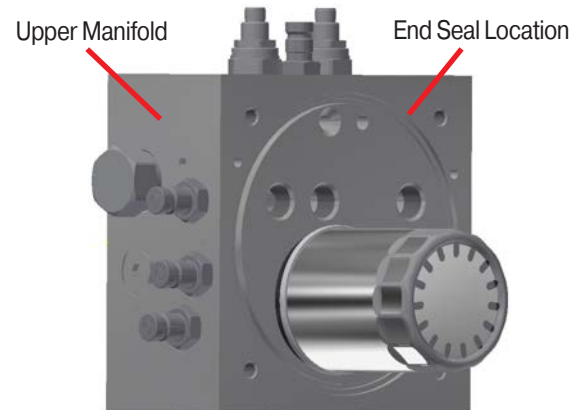
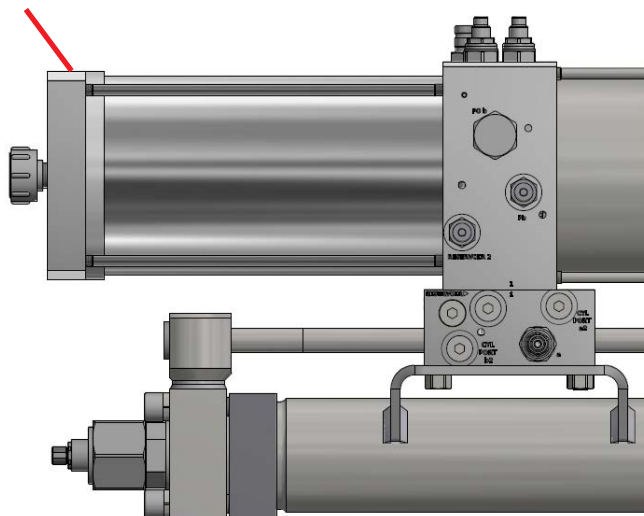

Figure 6 Filter Install



Figure 7 Bladder Install



Figure 8 End Seal installation in Reservoir Cap



Figure 9 End cap and tube alignment

**⚠ PROP 65 WARNING** **WARNING:** This product can expose you to chemicals including Lead and Lead Compounds which are known to the State of California to cause cancer and birth defects or other reproductive harm. For more information go to [www.P65Warnings.ca.gov](http://www.P65Warnings.ca.gov)

# Cylinder Fluid Exchange

Depending on your Rod size and stroke the majority of the system fluid maybe located inside the cylinder assembly. When performing an oil change this fluid will need to be removed from the system and exchanged with new clean oil.

Parker Cylinder Division offers a fluid exchange service for a nominal fee. Please contact Cylinder and Accumulator Division at (847) 298-2400 if you would like us to service your HAS unit.

To exchange the fluid in the actuator, once the fluid from the reservoir has been drained and rebuilt, you must use an external power unit fitted with a oil purging circuit with the ability to route the fluid to a waste container. The Power Unit should be fitted with both Pressure, Return Filtration, suggested 2Q element sizing. It will also require a particle counter for real time ISO contamination measuring. See figure 6 for hydraulic circuit suggestions.



Before connection to the HAS unit, identify the type of load holding valves and ensure fluid will be blocked from returning to the HAS Reservoir. See page 30 for details on valve types.

If your configuration is for "N" (No Load Holding), this option is a PO check with a manual override, the manual override must be adjusted fully counterclockwise during exchange to allow check valve to seat. If you have a special setting on the counterbalance valve, less than 1500 PSI, you will need to increase the setting to prevent the relieving function from allowing fluid to enter the reservoir. Failure to block flushing fluid will damage the HAS bladder assembly.

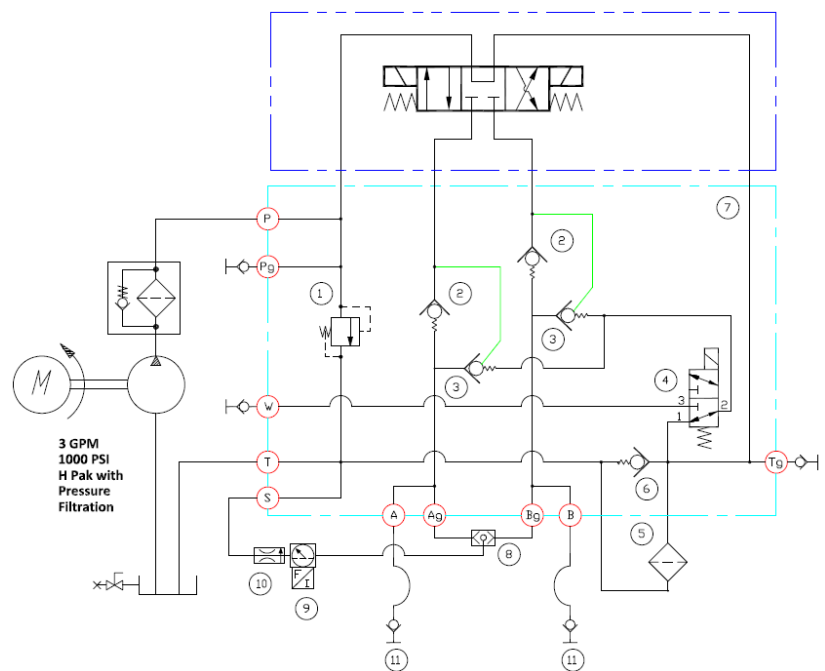

Figure 6 Cyl Exchange Schematic

Port	Size	Description
P	SAE-8	Pressure Supply from H Pak
PG	SAE-4	Pressure Gauge Connection
W	SAE-12	Waste Oil Outlet
T	SAE-12	Return / Tank port for H Pak
S	SAE-12	Return Port for Particle Counter
A	SAE-8	HAS Flush Port connection FF coupler
Ag	SAE-4	Shuttle Valve for Particle Counter
B	SAE-8	HAS Flush Port connection FF coupler
Bg	SAE-4	Shuttle Valve for Particle Counter

Item	Qty	Part Number	Description	MFG
1	1	RAH101S10	Pressure Relief Cartridge	Parker
2	2	CVH081P	Check Valve	Parker
3	2	CPC101P	Pilot to Close Check Valve	Parker
4	1	DSL103N	Waste Oil Selector Valve	Parker
5	1	942205	12 CS Filter	Parker
6	1	CVH081P-100	Check Valve 100 PSI Crack	Parker
7	1	MFP-MB-6248-BNO	Manifold	MFP
8	1	ASH-04-03	Shuttle Valve	Parker
9	1	IPD19322230	Particle Counter	Parker
10	1	ACC6NN019	Flow Control for Icount	Parker
11	2	FF 251 xFO	FF coupler	Parker

**PROP 65 WARNING** WARNING: This product can expose you to chemicals including Lead and Lead Compounds which are known to the State of California to cause cancer and birth defects or other reproductive harm. For more information go to [www.P65Warnings.ca.gov](http://www.P65Warnings.ca.gov)



## Cylinder Fluid Exchange HAS Connections

The Hydraulic Power Unit must be filled with clean fluid matching the type of the HAS configuration. Please see page 8 for HAS 500, page 10 for HAS-ST for details on model code. All HAS units are fitted with a pair of FF couplers for fluid flushing.

Locate the FF nipple on the HAS Power Pack, standard configurations will have the nipples on left, right or both sides. The model code will indicate the configuration. Detached units, the Nipples are located under the motor and reservoir assembly. Ensure load holding valves are adjusted correctly. Connect Hoses to the FF nipples.

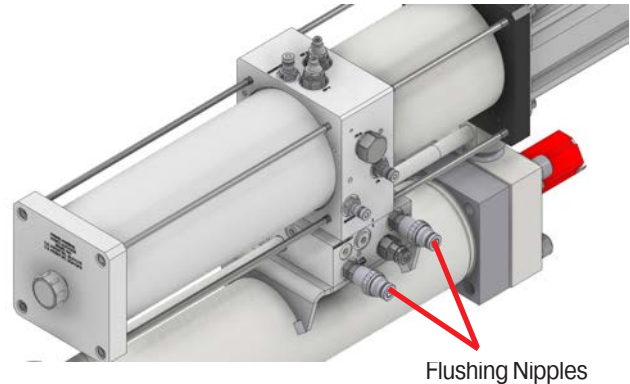

**Warning:** Cylinder will move during this process, care must be take to ensure no hazards or pinch points caused during cycling of the cylinder.

Adjust flushing power unit pressure to maximum of 1000 PSI.

To replace the fluid in the HAS cylinder, energize the 3 Way Selector Valve (Item 4) to route fluid to waste port, ensure the waste oil is in a separate container , not the power unit reservoir.

Depending on the condition of the fluid, cycle the cylinder until it bottoms out full extension if just a typical oil exchange or (2) full strokes if heavily contaminated, to ensure dirty oil is exchanged form the system.

Once completed, de-energize 3 Way Selector Valve (Item 4) to route fluid back to the flushing power unit.

Ensure counter or similar particle counter is active and monitor levels.

Cylinder should be cycled in full extension and full retraction until the Particle Counter reads better than 18/16/13, preferred 16/14/11. All air must be purged from the system, typically, requiring ~25 cycles.

When fluid is at acceptable level, ensure cylinder is in full retract position, and flushing hose maybe removed.

Return load holding valves to the original settings, before moving to reservoir filling.



### PROP 65 WARNING

**WARNING:** This product can expose you to chemicals including Lead and Lead Compounds which are known to the State of California to cause cancer and birth defects or other reproductive harm. For more information go to [www.P65Warnings.ca.gov](http://www.P65Warnings.ca.gov)

# Vacuum Systems Components



To properly fill a HAS reservoir, and not cause damage to the internal components, it is recommended to pull a vacuum on the reservoir and bladder assembly while filling. Commercially available parts need to be slightly modified for this operation. Example parts list below:

Item	Qty	Part Number	Manufacture	Description
A	1	P0664FBAUK	BACO	3 gallon Vacuum chamber kit
B	1	1ZM-IDS-00061	Uenede (Amazon)	1/4" NPT to 1/2" Bulkhead Fitting
C	1	6340 56 00WP2	Parker	LIQUFIT Y tee
D	1	6509 60 18WP2	Parker	3/8" tube to 3/8" NPT
E	2	6505 56 14WP2	Parker	LIQUFIT 1/4 tube to 1/4" NPT
F	1	PD242	Parker	Coupler 1/4" NPT Female
G	1	25-C	Parker	1/4" NPT Pneumatic Coupler
H	1	H2C-E	Parker	3/8" NPT Pneumatic Nipple
I	1	DA5036T	Duramaster	2.5 Gallon Pressurized Reservoir, 5 x 36" Tank
I	1	DA8036T	Duramaster	6 Gallon Pressurized Reservoir, 8 x 36" Tank

**⚠ PROP 65 WARNING** **WARNING:** This product can expose you to chemicals including Lead and Lead Compounds which are known to the State of California to cause cancer and birth defects or other reproductive harm. For more information go to [www.P65Warnings.ca.gov](http://www.P65Warnings.ca.gov)

## Vacuum Chamber Modifications

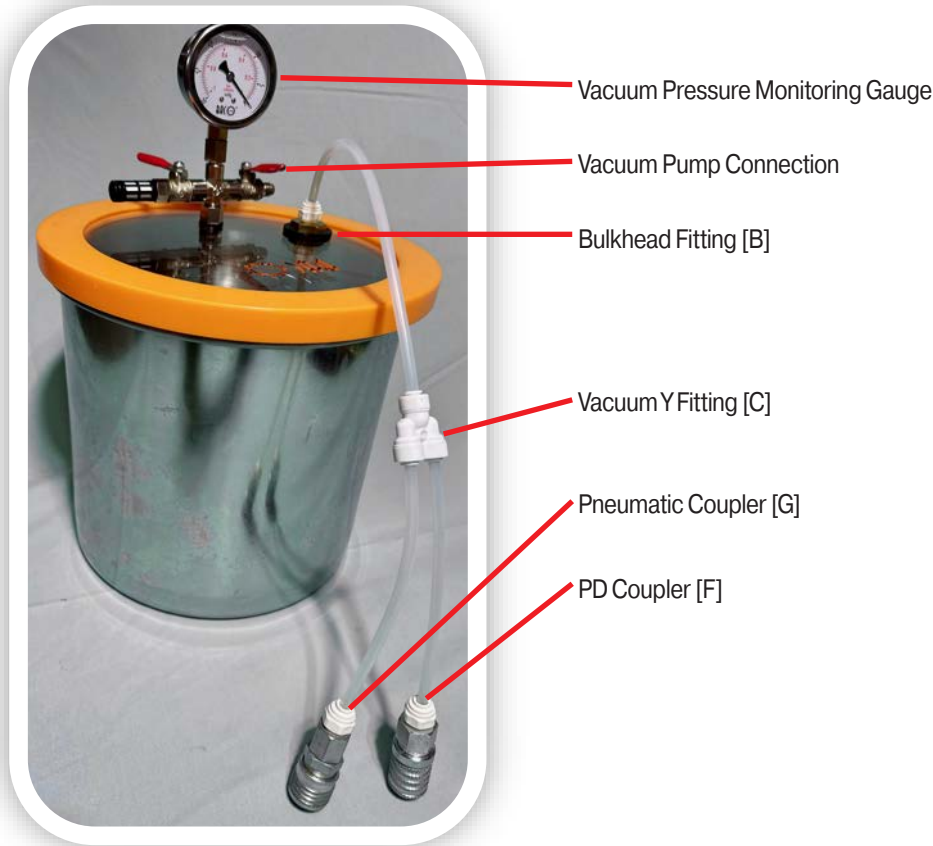

1. Drill 13/16" hole in the Vacuum Chamber cover, and install the bulkhead fitting, use supplied washers to ensure vacuum is maintained.
2. Install LIQUFIT fitting into adapter [E]
3. Install desired 1/4" OD clear nylon tubing. Tubing must be transparent, for monitoring when all air is evacuated form the HAS unit .
4. Install Ytee fitting [C] to end of Nylon tubing
5. Install desired length of 1/4" nylon tubing for connection the top of HAS Upper manifold and Reservoir End Cap. Reservoir end cap tubing should be a minimum of 3 feet to ensure fluid doesn't transfer to bladder during filling
6. Install PD coupler [F] to tube connected to Top of HAS upper Manifold .
7. Install Pneumatic Coupler to tubing end connected to Reservoir End Cap.
8. Connect Exhaust muffler to Vacuum gauge assembly.
9. Connect Vacuum Pump Hose to other end of Gauge assembly.
10. Turn on Vacuum pump and pull 20 hg, ensuring no vacuum leaks in the chamber.

**⚠ PROP 65 WARNING** **WARNING:** This product can expose you to chemicals including Lead and Lead Compounds which are known to the State of California to cause cancer and birth defects or other reproductive harm. For more information go to [www.P65Warnings.ca.gov](http://www.P65Warnings.ca.gov)

## Fluid Fill Reservoir

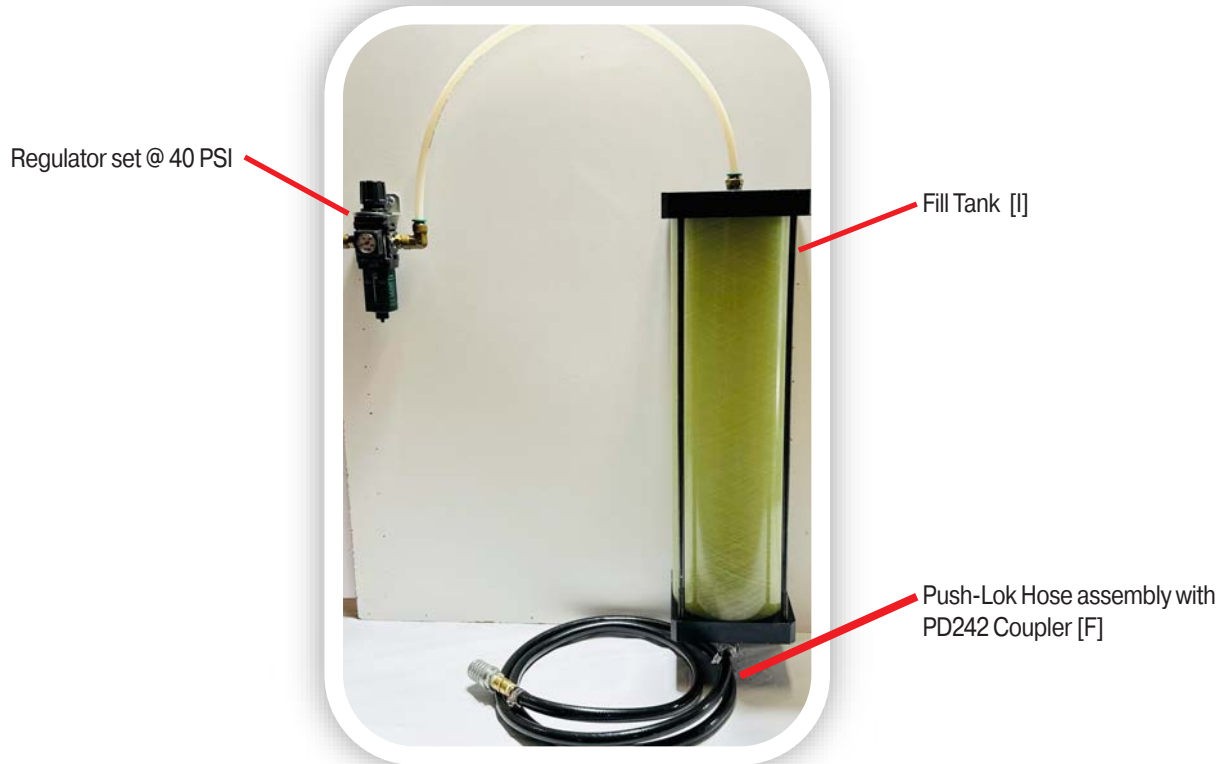

When filling or topping off HAS reservoirs, it strongly recommend to use DuraMaster fill tank. See page 54 for part numbers and sizes. The tank should be filled with Clean fluid matching the fluid specification in the HAS model code. See page HAS Model Code for more details.

The Fill reservoir has (2) 3/8" NPT ports on each end of the oil sides, its suggested to use a Push Lok hose assembly for connection to the HAS Fill reservoir. The HAS fill port must be fitted with a PD242 Coupler.

Tank may be filled with the PD coupler, flow rate must not exceed 0.5 GPM. Remove air pressure when filling.

The Air side must be regulated not to exceed 40 PSI with clean dry air. Fitted with a FRL is suggested.



Failure to regulate the Oil Fill pressure could result in HAS component damage, pressures must not exceed 40 PSI.

**PROP 65 WARNING** **WARNING:** This product can expose you to chemicals including Lead and Lead Compounds which are known to the State of California to cause cancer and birth defects or other reproductive harm. For more information go to [www.P65Warnings.ca.gov](http://www.P65Warnings.ca.gov)

# HAS Reservoir Filling

**Step 1:** Cylinder must be in full retract position before filling process or damage will occur to bladder during operation.



**Step 2:** Fill HAS Reservoir with appropriate fluid. It is not recommended to mix hydraulic fluid.

**Fluid Must Be Clean before filling. Recommend ISO code better than 18/16/13, preferred 16/14/11.**

Fluid fill thru the Push Lok hose / PD coupler assembly with the air line removed or regulator vented. Do not exceed 0.5 GPM when filling.

Fill reservoir to desired level, leaving a minimum 6-7" of air space on top of fluid.



Fluid Level at Maximum



Fluid Level at Minimum

**Step 3:** Remove breather cap from back side of reservoir. Install pneumatic fitting to cap. The fitting must be of type to allow for quick release of vacuum on reservoir bladder. A Parker H2C-E fitting is recommended.



**⚠ PROP 65 WARNING** **WARNING:** This product can expose you to chemicals including Lead and Lead Compounds which are known to the State of California to cause cancer and birth defects or other reproductive harm. For more information go to [www.P65Warnings.ca.gov](http://www.P65Warnings.ca.gov)

## HAS Reservoir Filling

**Step 4:** HAS unit must be positioned horizontal during the fill process.

Elevate the Motor End of Has Unit slightly with a small block under head or cap depending on motor orientation. under cylinder end cap, either Head or Cap, depending on Reservoir Orientation. Reservoir 1 port should be highest point of the reservoir during Fill. **Do not connect fill hose at this step.**

**Step 5:** Connect the PD coupler (PD242) to the top of upper Manifold port stamped Reservoir 1. Connect the 25C coupler to back face of the reservoir Cap.

**Step 6:** Turn on Vacuum pump and bring vacuum to 20 inch-hg.

Shut vacuum on and off to maintain vacuum of 20 inch-hg +/- 5 inch-hg. Vacuum should hold equalizing pressure.

**Step 7:** On Reservoir Fill tank, apply clean dry air to the FRL and set regulated pressure to 40 PSI.



Failure to regulate the Oil Fill pressure could result in HAS component damage, pressures must not exceed 40 PSI.

**Step 8:** Connect Push Lok hose with PD coupler to Reservoir 2 port located on the "b" side of the upper manifold.

The filling process will begin at this point. Monitor Reservoir Fill Tank level, if level drops to less than 6" oil Level, disconnect fill hose and refill. Monitor vacuum and air pressure to ensure settings are maintained.

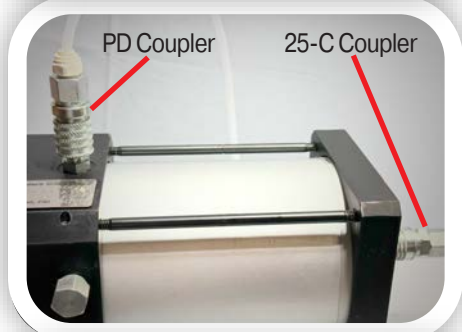

**⚠ PROP 65 WARNING** **WARNING:** This product can expose you to chemicals including Lead and Lead Compounds which are known to the State of California to cause cancer and birth defects or other reproductive harm. For more information go to [www.P65Warnings.ca.gov](http://www.P65Warnings.ca.gov)

## HAS Reservoir Filling

**Step 9:** During the fill process, air will be evacuated from the reservoir thru the Reservoir 1 Port located on the top of the upper manifold. The differential pressure created by the 40 PSI fill tank will col-lapse the bladder allowing for reservoir tank to be filled.

Monitor the translucent tubing, when oil is seen, rock the HAS unit from side to side to release any trapped air under the bladder,. Excess oil will be transferred into the vacuum chamber for reuse. One to Two minutes of fluid flow without bubbles, while rocking the HAS unit, is recommended for proper air removal.

**Step 10:** When a solid stream of oil is flowing thru the vacuum line, with no air bubbles, remove the Push Lok Fill hose from the Reservoir 2 port.

Immediately remove the Pneumatic coupler from the reservoir end cap, leaving the only HAS connection Reservoir 1.

Start a timer, and wait 10-12 seconds.

Remove PD coupler from Reservoir 1.

To verify process is complete, remove the pneumatic nipple (H2C-E) from Reservoir end plate.

Using a well rounded, non-sharp tool, 1/4" socket drive extension works well, insert into the back side of the reservoir.

The Bladder should be firm, and allow some movement with minimal force.

The bag should not be hard to the touch. If so remove some additional fluid from Reservoir 1 connection with the Vacuum chamber.

If the bladder is not compressed to greater than 80% fill volume repeat step 6.

When bladder fill is complete re-install breather cap in reservoir End Plate.

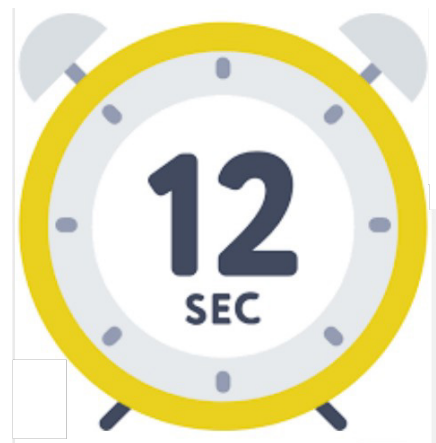

**PROP 65 WARNING** **WARNING:** This product can expose you to chemicals including Lead and Lead Compounds which are known to the State of California to cause cancer and birth defects or other reproductive harm. For more information go to [www.P65Warnings.ca.gov](http://www.P65Warnings.ca.gov)

# Detached HAS Units

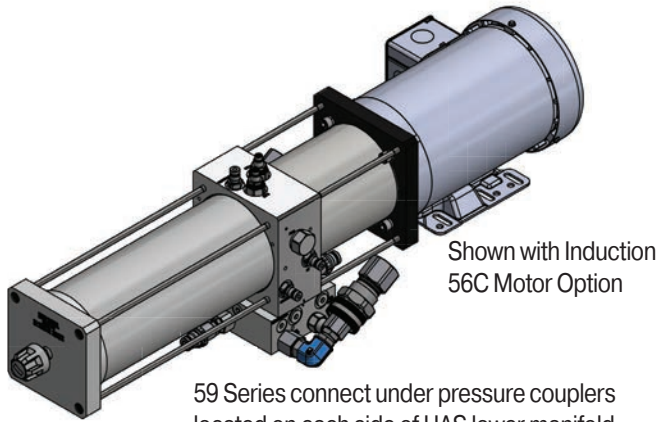

Shown with Induction  
 56C Motor Option

59 Series connect under pressure couplers located on each side of HAS lower manifold

Detached HAS Units are matched to appropriate cylinder and must be purchased as an assembly.

HAS Detached units are flushed and filled as standard HAS units with integral power packs.

Units are fitted with flexible hose assemblies installed on the cylinder.

Hoses supplied must have male 3/4-16 (SAE -8) on each end.

Unit is detached with the use of Parker 59 Series connect under pressure couplers. Nipples mounted on HAS unit, couplers on cylinder hose ends.

Push and Pull valve selections are specified in the HAS model code. for proper operation Cylinder Port "a2" must be connected to the cylinder Cap (blind) End. "b2" must be connected to the cylinder's Head (rod) End.

Never Operate without both hoses connected. Proper connection is obtained when Orange O-Ring is no longer visible on 59 Series Nipple located on HAS Power Pack

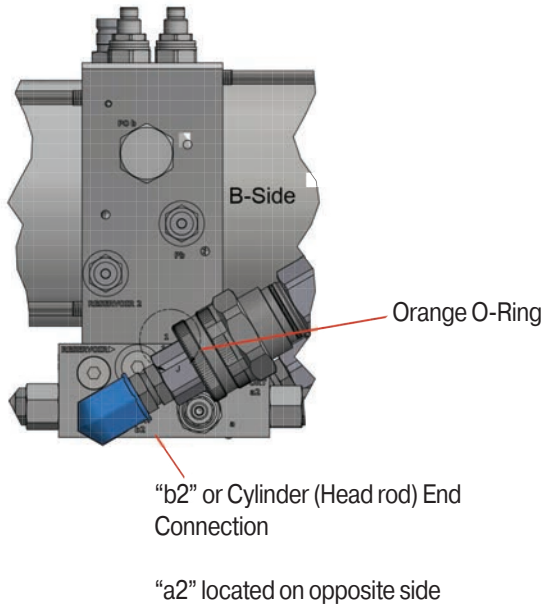

## Hydraulic Schematic

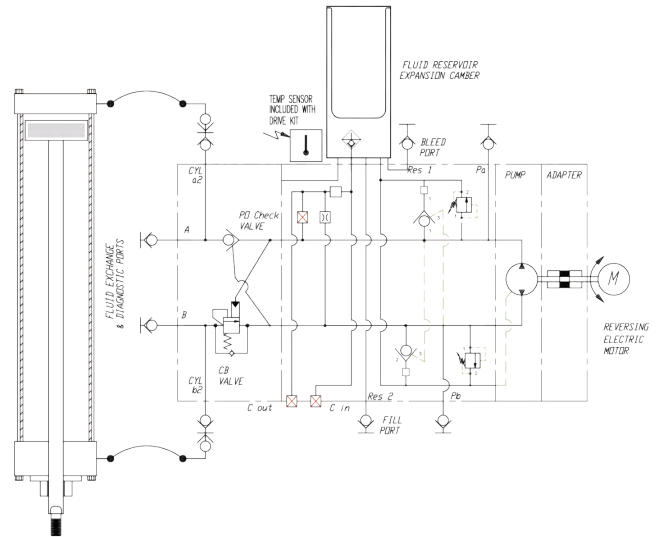

## Mounting Dimensions

When using an induction motor, Motor and HAS mounting must be used to support added weight

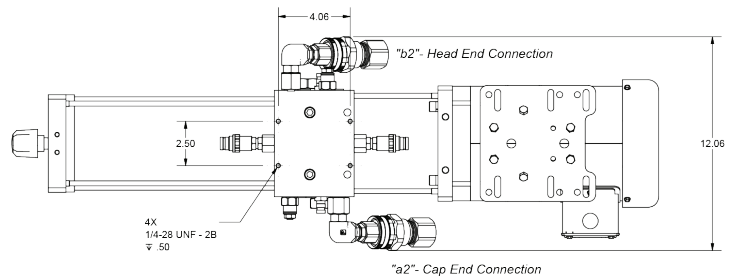

Power Pack maybe mounted Horizontal or Vertical with Reservoir UP. Vertical mounting with Reservoir Down, or horizontal with "A" side up is not recommended. Consult Factory for more details. Refer to HAS Catalog HY08-4005-1 for additional information.

**PROP 65 WARNING** **WARNING:** This product can expose you to chemicals including Lead and Lead Compounds which are known to the State of California to cause cancer and birth defects or other reproductive harm. For more information go to [www.P65Warnings.ca.gov](http://www.P65Warnings.ca.gov)

# HAS Inner Connect Plumbing Line Flushing

The following recommendations are suggested as guidelines:

## General

Hybrid Actuation System (HAS) can generally tolerate certain particles with sizes up to 25 microns, however pump clearances are typically limited to less than 5 microns. Clean oil extends system life. Since HAS units are sealed systems, they are flushed clean during the assembly/testing process to ensure proper system life. All HAS units are flushed to 16/14/11 ISO codes during remove testing.

With Detached HAS units, care must be taken not to introduce contaminants when connecting the 59 series couplers, Clean Couplers and nipples before installing.

On Detached HAS power packs, if inner connect plumbing is intended to be used, the plumbing must be cleaned to a level ISO code 16/14/11, and all air purged from the system. This is accomplished by using 2 or 5 micron absolute rated filters on both the supply and return lines, and flushing the total volume of oil through the plumbing 300 to 600 times, with periodic fluid sampling done with a fluid Particle Counter. When particulate meet or exceed ISO 16/14/11 the HAS power pack and cylinder may be connected.

**HAS Power pack must not be connected to external plumbing lines until fluid is confirmed to be clean to an ISO level equal to or better than 16/14/11 and free of all air. Flush Faced quick dis-connects equal to Parker 59 series must be used to eliminate air ingestion.**

**Failure to do so will require returning entire HAS system to Parker for oil change out and refilling.**

## Formula for Flushing Time

$$T = (V/F) \dots x \text{ 5(minimum) ... 10 Optimum}$$

T = Flushing time [Hours]

V = Plumbing capacity [gallons]

F = Flushing Pump flow [gpm]

5 = 300 circulations

10 = 600 circulation

$$V = (A \times L \times 2) / 231$$

A = Plumbing Area [Square -Inch]

L= Plumbing Length [Inch]

*(either Open or Close length, which ever is longer)*

**⚠ PROP 65 WARNING** **WARNING:** This product can expose you to chemicals including Lead and Lead Compounds which are known to the State of California to cause cancer and birth defects or other reproductive harm. For more information go to [www.P65Warnings.ca.gov](http://www.P65Warnings.ca.gov)

## HAS Application Guidelines

When specifying a HAS 500 you should use the HAS sizing tool, as it will optimize the motor, pump and drive/inverter requirements. Many Motor and Pump displacements available.

When using PO Check Valves and duty cycles is 50% or greater, you will be required to use a Heat Exchanger as the pressure drops will create heat in the reservoir tube cannot be dissipated. PO Checks will chatter if any runaway loads are present, therefore they should only be used on horizontal applications or combined with Counterbalance in non loaded direction.

When using Counterbalance Valves and duty cycles is 30% or greater, you will be required to use a Heat Exchanger as the pressure drops will create heat the reservoir tube can not be dissipated.

When using in Closed Loop Position control, the recommended valve selection is Counterbalance Valves in Push and Pull to provide braking. Low pressure leg is directly connected to reservoir. Custom settings available with pressure as low as 250 PSI typical range is 1000-4000 PSI.

HAS Series ST units are designed for intermittent use.

Brushed DC motors.  
(2) options 245 watt or 560 watt motor.  
12V or 24V DC voltage.  
Four pump displacements available  
(2) cataloged, 0.16 cc/rev and 0.31 cc/rev  
Optional 0.41 cc/rev, and 0.53 cc/rev.



**WARNING:** This product can expose you to chemicals including Lead and Lead Compounds which are known to the State of California to cause cancer and birth defects or other reproductive harm. For more information go to [www.P65Warnings.ca.gov](http://www.P65Warnings.ca.gov)



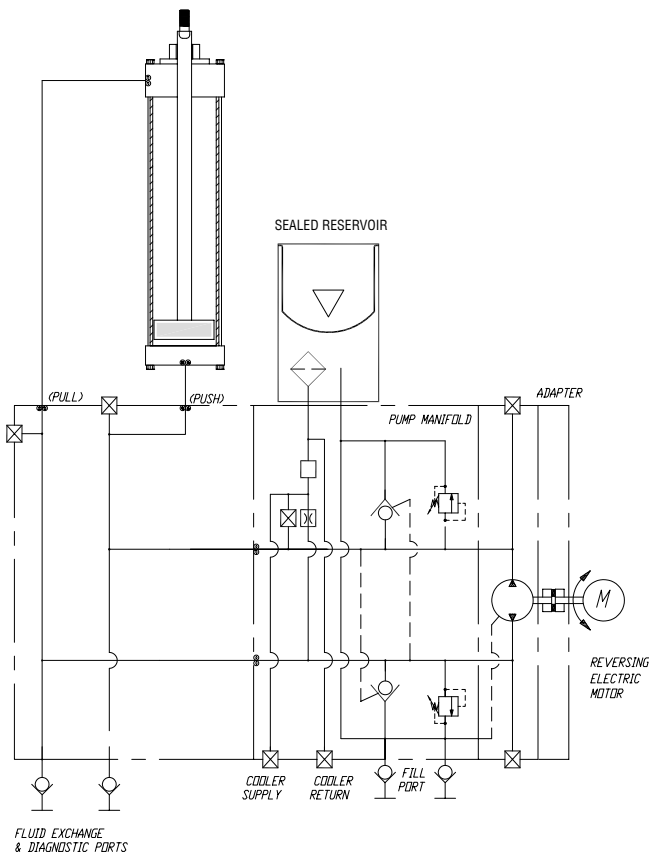

**No Load Holding  
 Order Code NN**

This configuration is most efficient, however actuator must be friction held to prevent runaway condition.

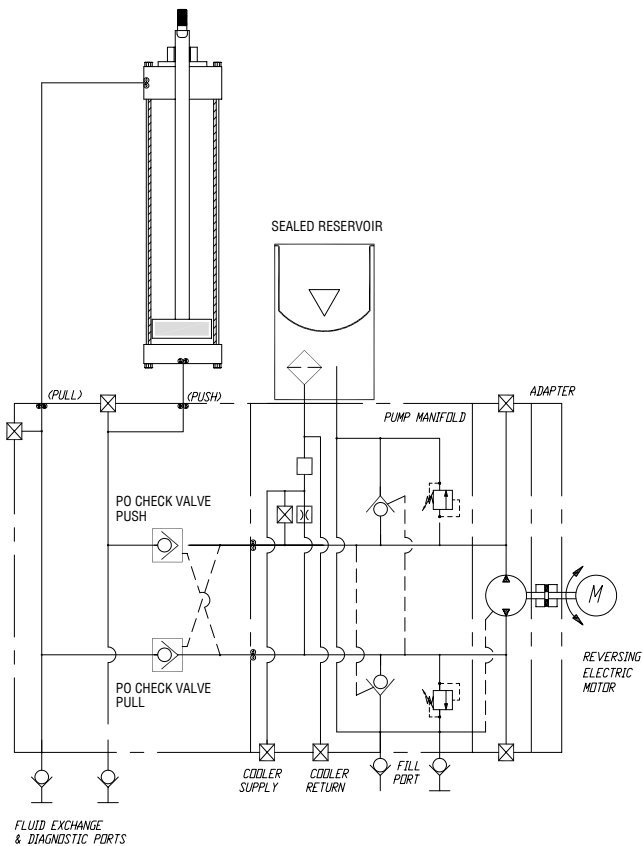

**Dual Pilot Operated Checks  
 Order Code PP**

This configuration is used where the actuator must be hydraulically locked in place.

- The 3 port Pilot to Open check valves have heat treated poppet and seats for long life and extremely low leakage.
- Pilot ratio of 3:1

**Order Code RR**

This configuration is used where the actuator must be hydraulically locked in place.

- The 3 port Pilot to Open check valves have heat treated poppet and seats for long life and extremely low leakage.
- Pilot ratio of 3:1
- Includes Manual Load Release

**PROP 65 WARNING** WARNING: This product can expose you to chemicals including Lead and Lead Compounds which are known to the State of California to cause cancer and birth defects or other reproductive harm. For more information go to [www.P65Warnings.ca.gov](http://www.P65Warnings.ca.gov)



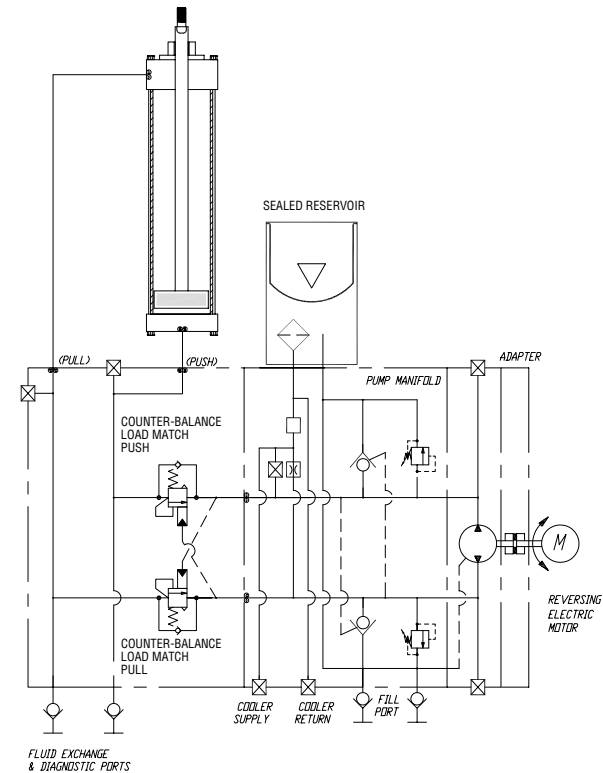

**Dual Counterbalance Valve**

**Order Code CC**

For use with Over running loads in both directions.

- 3:1 pilot ratio with setting of 3000 standard.
- 4 PSI cracking check pressure standard for free flow check.
- Valve setting should be greater than 1.3 times the load induced pressure.
- Counterbalance valves provide thermal expansion protection and are suitable for outdoor applications.

**Dual Load Match CB Valve**

**Order Code LL**

Load-match counterbalance valves are self setting counterbalance valves

- Adjust dynamically in response to the load pressure up to the valve thermal relief setting. These valves provide reduced energy consumption over fixed setting counterbalance valves.
- Max recommend holding pressure is 3075 PSI.
- Cracking pressure is 3850-4250 PSI, thermal protection, suitable for outdoor HAS applications.

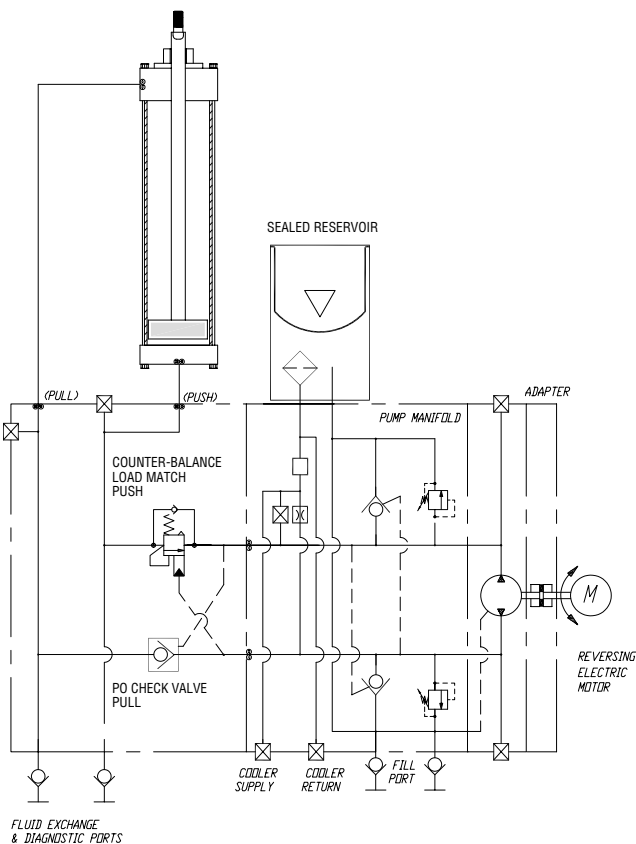

**Mix & Match**

With individual order code for valves for both Push and Pull circuits, you can customize your load holding circuit to meet your system demands and energy losses.

**Other**

Consult factory for additional circuit options

- Hydraulic Regeneration
- Spring Return
- Servo Positioning
- Manual Bypass - Hand Pump

**PROP 65 WARNING** WARNING: This product can expose you to chemicals including Lead and Lead Compounds which are known to the State of California to cause cancer and birth defects or other reproductive harm. For more information go to [www.P65Warnings.ca.gov](http://www.P65Warnings.ca.gov)

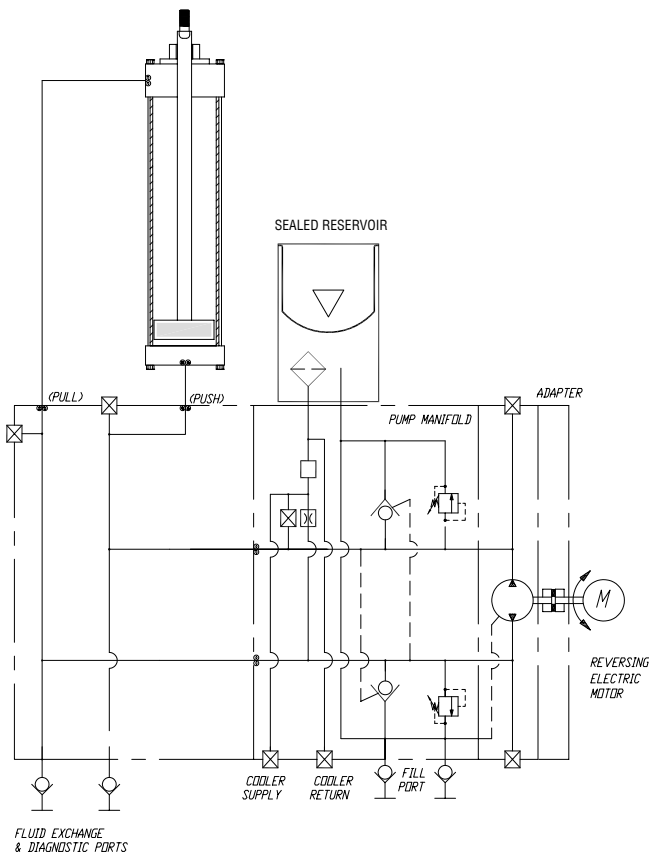

**No Load Holding  
 Order Code NN**

This configuration is most efficient, however actuator must be friction held to prevent runaway condition.

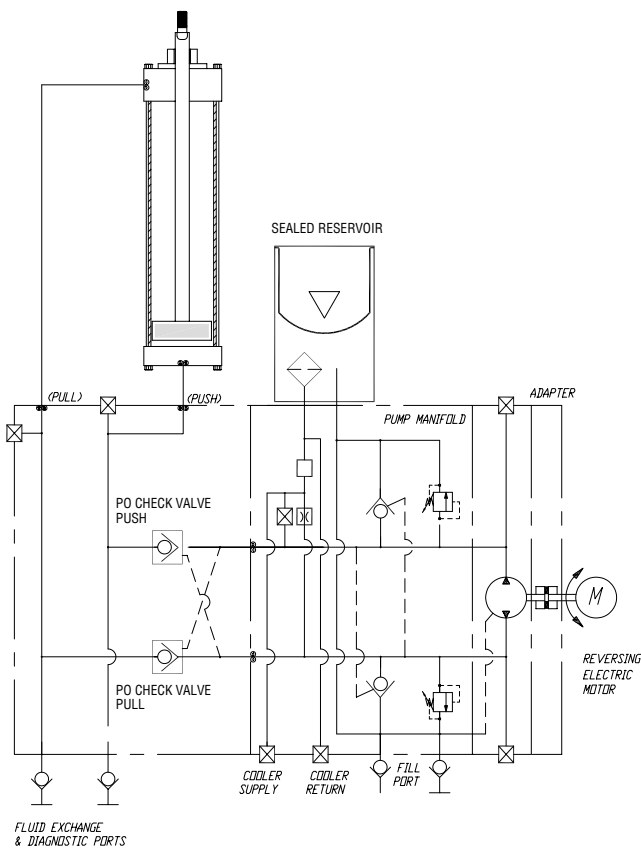

**Dual Pilot Operated Checks  
 Order Code PP**

This configuration is used where the actuator must be hydraulically locked in place.

- The 3 port Pilot to Open check valves have heat treated poppet and seats for long life and extremely low leakage.
- Pilot ratio of 3:1

**Order Code RR**

This configuration is used where the actuator must be hydraulically locked in place.

- The 3 port Pilot to Open check valves have heat treated poppet and seats for long life and extremely low leakage.
- Pilot ratio of 3:1
- Includes Manual Load Release

**PROP 65 WARNING** WARNING: This product can expose you to chemicals including Lead and Lead Compounds which are known to the State of California to cause cancer and birth defects or other reproductive harm. For more information go to [www.P65Warnings.ca.gov](http://www.P65Warnings.ca.gov)

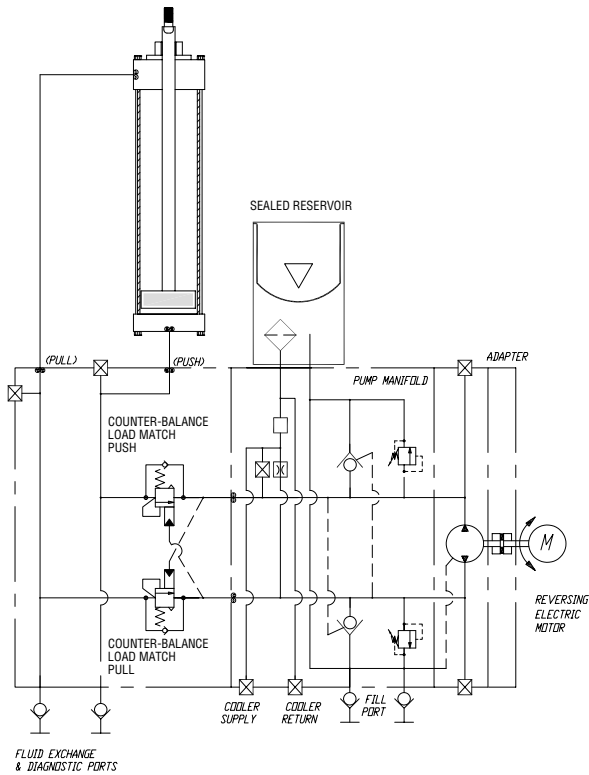

### Dual Counterbalance Valve

#### Order Code CC

For use with Over running loads in both directions.

- 3:1 pilot ratio with setting of 3000 standard.
- 25 PSI cracking check pressure standard for free flow check.
- Valve setting should be greater than 1.3 times the load induced pressure.
- Counterbalance valves provide thermal expansion protection and are suitable for outdoor applications.

### Dual Counterbalance Valve

#### Order Code DD

For use with Over running loads in both directions.

- 10:1 pilot ratio with setting of 4000 standard.
- 25 PSI cracking check pressure standard for free flow check.
- Valve setting should be greater than 1.3 times the load induced pressure.
- Counterbalance valves provide thermal expansion protection and are suitable for outdoor applications.

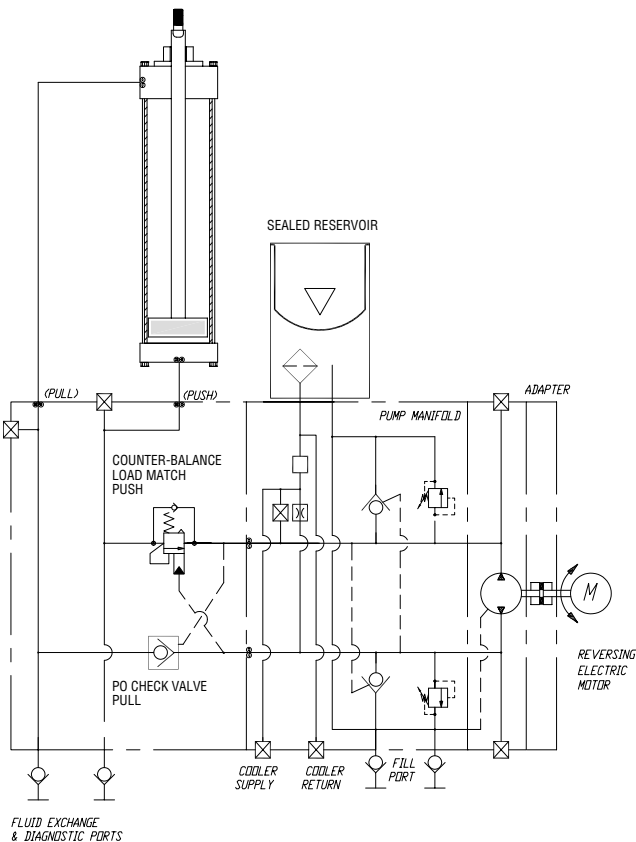

### Mix & Match

With individual order code for valves for both Push and Pull circuits, you can customize your load holding circuit to meet your system demands and energy losses.

HAS-ST Manifold options are limited to listed Load Holding Options

**PROP 65 WARNING** WARNING: This product can expose you to chemicals including Lead and Lead Compounds which are known to the State of California to cause cancer and birth defects or other reproductive harm. For more information go to [www.P65Warnings.ca.gov](http://www.P65Warnings.ca.gov)

## HAS Power Pack Placement

HAS reservoirs are vacuum filled and sealed from the elements, however in the unlikely even of a reservoir bladder failure or vacuum loss, reservoir placement is important. Its not recommended to mount vertically reservoir down orientation.

Also when positioned in port location number 3, with the A side "up", at time of order, special notes should be added to relocate pump inlets to ensure proper pump inlet conditions if vacuum loss. The "A" side is determined by the cartridge valve stamps " labeled" a, looking at the motor mount, "A" side would be on right, "B" on left.

### Vertical Mounts

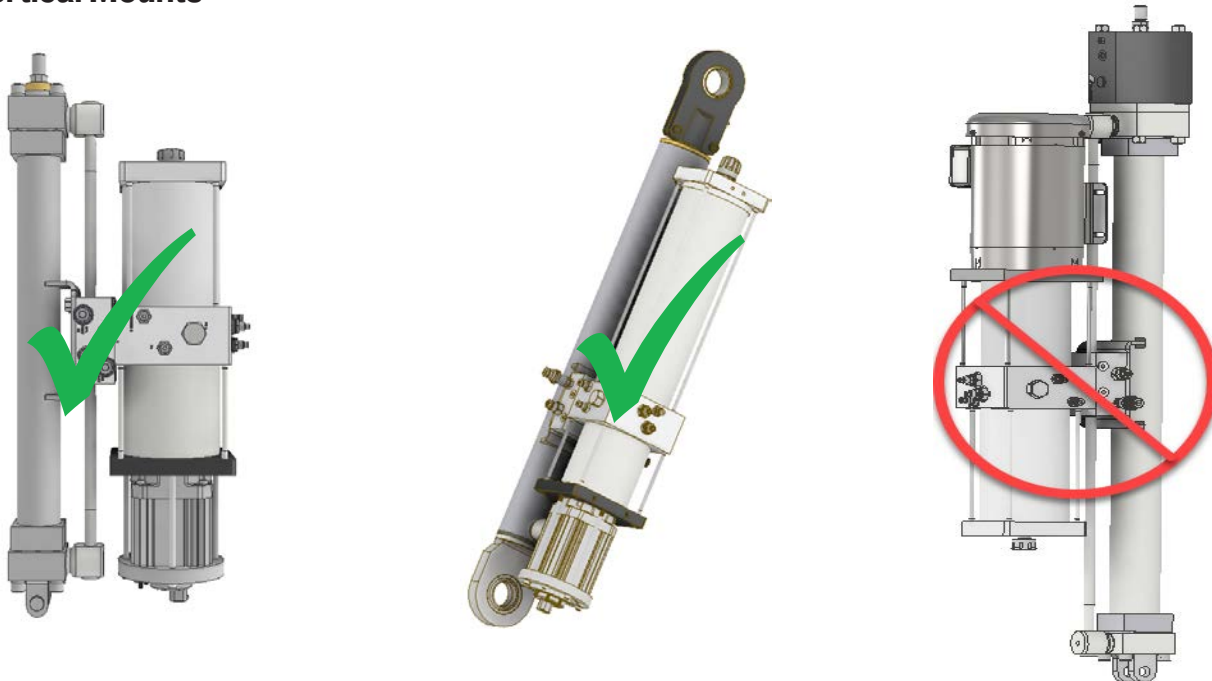

### Horizontal Mounts

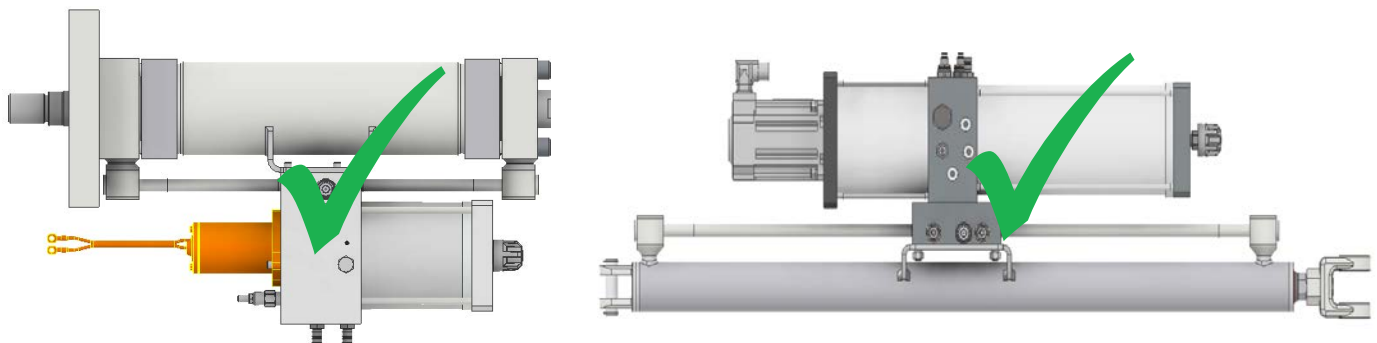

**⚠ PROP 65 WARNING** **WARNING:** This product can expose you to chemicals including Lead and Lead Compounds which are known to the State of California to cause cancer and birth defects or other reproductive harm. For more information go to [www.P65Warnings.ca.gov](http://www.P65Warnings.ca.gov)

# Horizontal Placement - HAS 500

HAS 500 units reservoir designs allow for some vacuum/oil loss. This is accomplished with down pipes and elbows locating the pump inlets below oil level. The down pipe and elbows are positioned to the center of the makeup oil reservoir. This allows for maximum utilization of the fluid reservoir when power back is placed on the top or bottom of the base cylinder. However when positioning the HAS power pack on the side of the cylinder, and mounted horizontally mounted with the "A" or "B" side up, the amount of vacuum loss is reduced. It is recommended at time of order to request a special placement of the inlet elbows.

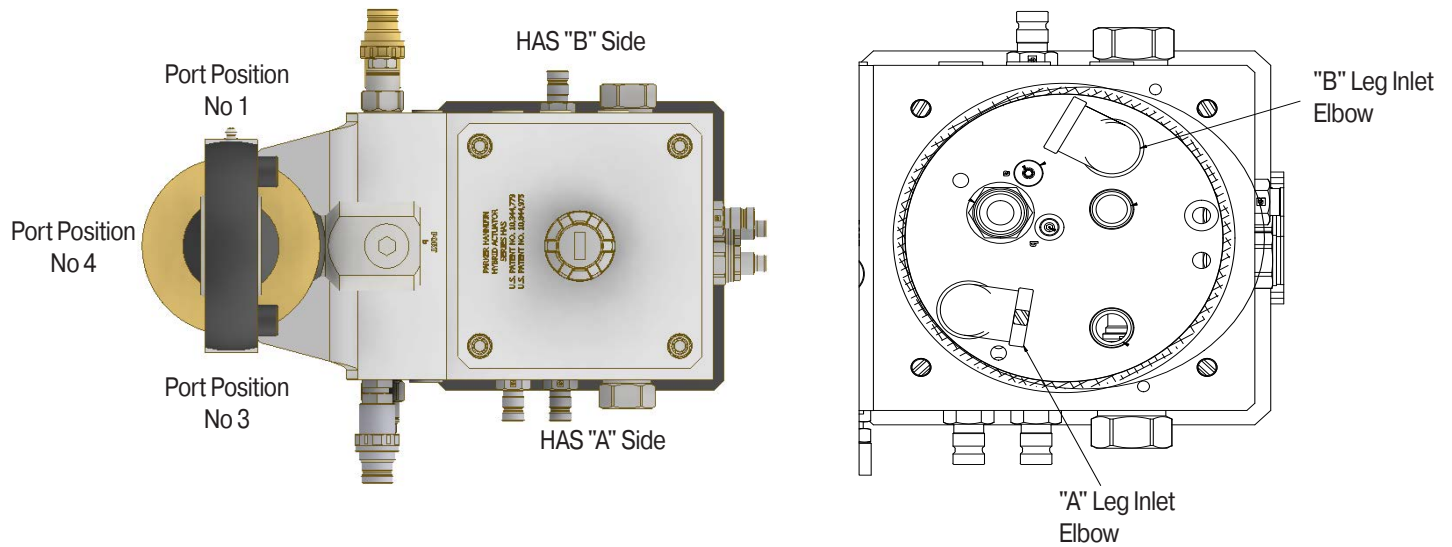

HAS Power Pack located at port Position 2, with "A" side up. Viewed from Rod End (Cylinder) and Reservoir End HAS. This configuration would require special pump inlet adjustment

## Cylinder Port (HAS Mounting Location)

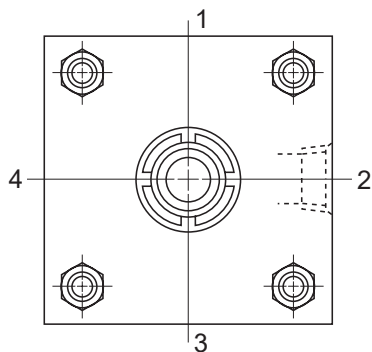

HAS Power Pack may be placed on any port position of the cylinder. Placement is based upon port number positions, 1 through 4 when viewed from the rod end of the cylinder.

**PROP 65 WARNING** **WARNING:** This product can expose you to chemicals including Lead and Lead Compounds which are known to the State of California to cause cancer and birth defects or other reproductive harm. For more information go to [www.P65Warnings.ca.gov](http://www.P65Warnings.ca.gov)

## Safety Guide for Selecting and Using Hydraulic, Pneumatic Cylinders and Their Accessories

**WARNING:**  **FAILURE OF THE CYLINDER, ITS PARTS, ITS MOUNTING, ITS CONNECTIONS TO OTHER OBJECTS, OR ITS CONTROLS CAN RESULT IN:**

- Unanticipated or uncontrolled movement of the cylinder or objects connected to it.
- Falling of the cylinder or objects held up by it.
- Fluid escaping from the cylinder, potentially at high velocity.

**THESE EVENTS COULD CAUSE DEATH OR PERSONAL INJURY BY, FOR EXAMPLE, PERSONS FALLING FROM HIGH LOCATIONS, BEING CRUSHED OR STRUCK BY HEAVY OR FAST MOVING OBJECTS, BEING PUSHED INTO DANGEROUS EQUIPMENT OR SITUATIONS, OR SLIPPING ON ESCAPED FLUID.**

Before selecting or using Parker Hannifin Corporation (the Company) cylinders or related accessories, it is important that you read, understand and follow the following safety information. Training is advised before selecting and using the Company's products.

### 1.0 General Instructions

**1.1 Scope** – This safety guide provides instructions for selecting and using (including assembling, installing, and maintaining) cylinder products. This safety guide is a supplement to and is to be used with the specific Company publications for the specific cylinder products that are being considered for use.

**1.2 Fail Safe** – Cylinder products can and do fail without warning for many reasons. All systems and equipment should be designed in a fail-safe mode so that if the failure of a cylinder product occurs people and property won't be endangered.

**1.3 Distribution** – Provide a free copy of this safety guide to each person responsible for selecting or using cylinder products. Do not select or use the Company's cylinders without thoroughly reading and understanding this safety guide as well as the specific Company publications for the products considered or selected.

**1.4 User Responsibility** – Due to very wide variety of cylinder applications and cylinder operating conditions, the Company does not warrant that any particular cylinder is suitable for any specific application. This safety guide does not analyze all technical parameters that must be considered in selecting a product. The hydraulic and pneumatic cylinders outlined in this catalog are designed to the Company's design guidelines and do not necessarily meet the design guideline of other agencies such as American Bureau of Shipping, ASME Pressure Vessel Code etc. The user, through its own analysis and testing, is solely responsible for:

- Making the final selection of the cylinders and related accessories.
- Determining if the cylinders are required to meet specific design requirements as required by the Agency(s) or industry standards covering the design of the user's equipment.
- Assuring that the user's requirements are met, OSHA requirements are met, and safety guidelines from the applicable agencies such as but not limited to ANSI are followed and that the use presents no health or safety hazards.
- Providing all appropriate health and safety warnings on the equipment on which the cylinders are used.

**1.5 Additional Questions** – Call the appropriate Company technical service department if you have any questions or require any additional information. See the Company publication for the product being considered or used, or call 1-847-298-2400, or go to [www.parker.com](http://www.parker.com), for telephone numbers of the appropriate technical service department.

### 2.0 Cylinder and Accessories Selection

**2.1 Seals** – Part of the process of selecting a cylinder is the selection of seal compounds. Before making this selection, consult the "seal information page(s)" of the publication for the series of cylinders of interest.

The application of cylinders may allow fluids such as cutting fluids, wash down fluids etc. to come in contact with the external area of the cylinder. These fluids may attack the piston rod wiper and or the primary seal and must be taken into account when selecting and specifying seal compounds.

Dynamic seals will wear. The rate of wear will depend on many operating factors. Wear can be rapid if a cylinder is mis-aligned or if the cylinder has been improperly serviced. The user must take seal wear into consideration in the application of cylinders.

**2.2 Piston Rods** – Possible consequences of piston rod failure or separation of the piston rod from the piston include, but are not limited to are:

- Piston rod and or attached load thrown off at high speed.
- High velocity fluid discharge.
- Piston rod extending when pressure is applied in the piston retract mode.

Piston rods or machine members attached to the piston rod may move suddenly and without warning as a consequence of other conditions occurring to the machine such as, but not limited to:

- Unexpected detachment of the machine member from the piston rod.
- Failure of the pressurized fluid delivery system (hoses, fittings, valves, pumps, compressors) which maintain cylinder position.
- Catastrophic cylinder seal failure leading to sudden loss of pressurized fluid.
- Failure of the machine control system.

Follow the recommendations of the "Piston Rod Selection Chart and Data" in the publication for the series of cylinders of interest. The suggested piston rod diameter in these charts must be followed in order to avoid piston rod buckling.

Piston rods are not normally designed to absorb bending moments or loads which are perpendicular to the axis of piston rod motion. These additional loads can cause the piston rod to fail. If these types of additional loads are expected to be imposed on the piston rod, their magnitude should be made known to our engineering department.

The cylinder user should always make sure that the piston rod is securely attached to the machine member.

On occasion cylinders are ordered with double rods (a piston rod extended from both ends of the cylinder). In some cases a stop is threaded on to one of the piston rods and used as an external stroke adjuster. On occasions spacers are attached to the machine member connected to the piston rod and also used as a stroke adjuster. In both cases the stops will create a pinch point and the user should consider appropriate use of guards. If these

external stops are not perpendicular to the mating contact surface, or if debris is trapped between the contact surfaces, a bending moment will be placed on the piston rod, which can lead to piston rod failure. An external stop will also negate the effect of cushioning and will subject the piston rod to impact loading. Those two (2) conditions can cause piston rod failure. Internal stroke adjusters are available with and without cushions. The use of external stroke adjusters should be reviewed with our engineering department.

The piston rod to piston and the stud to piston rod threaded connections are secured with an anaerobic adhesive. The strength of the adhesive decreases with increasing temperature. Cylinders which can be exposed to temperatures above +250°F (+121°C) are to be ordered with a non studded piston rod and a pinned piston to rod joint.

**2.3 Cushions** – Cushions should be considered for cylinder applications when the piston velocity is expected to be over 4 inches/second.

Cylinder cushions are normally designed to absorb the energy of a linear applied load. A rotating mass has considerably more energy than the same mass moving in a linear mode. Cushioning for a rotating mass application should be reviewed by our engineering department.

**2.4 Cylinder Mountings** – Some cylinder mounting configurations may have certain limitations such as but not limited to minimum stroke for side or foot mounting cylinders or pressure de-ratings for certain mounts. Carefully review the catalog for these types of restrictions.

Always mount cylinders using the largest possible high tensile alloy steel socket head cap screws that can fit in the cylinder mounting holes and torque them to the manufacturer's recommendations for their size.

**2.5 Port Fittings** – Hydraulic cylinders applied with meter out or deceleration circuits are subject to intensified pressure at piston rod end.

The rod end pressure is approximately equal to:

$$\frac{\text{operating pressure} \times \text{effective cap end area}}{\text{effective rod end piston area}}$$

Contact your connector supplier for the pressure rating of individual connectors.

### 3.0 Cylinder and Accessories Installation and Mounting

#### 3.1 Installation

**3.1.1** – Cleanliness is an important consideration, and cylinders are shipped with the ports plugged to protect them from contaminants entering the ports. These plugs should not be removed until the piping is to be installed. Before making the connection to the cylinder ports, piping should be thoroughly cleaned to remove all chips or burrs which might have resulted from threading or flaring operations.

**3.1.2** – Cylinders operating in an environment where air drying materials are present such as fast-drying chemicals, paint, or weld splatter, or other hazardous conditions such as excessive heat, should have shields installed to prevent damage to the piston rod and piston rod seals.

**3.1.3** – Proper alignment of the cylinder piston rod and its mating component on the machine should be checked in both the extended and retracted positions. Improper alignment will result in excessive rod gland and/or cylinder bore wear. On fixed mounting cylinders attaching the piston rod while the rod is retracted will help in achieving proper alignment.

**3.1.4** – Sometimes it may be necessary to rotate the piston rod in order to thread the piston rod into the machine member. This operation must always be done with zero pressure being applied to either side of the piston. Failure to follow this procedure may result in loosening the piston to rod-threaded connection. In some rare cases the turning of the piston rod may rotate a threaded piston rod gland and loosen it from the cylinder head. Confirm that this condition is not occurring. If it does, re-tighten the piston rod gland firmly against the cylinder head.

For double rod cylinders it is also important that when attaching or detaching the piston rod from the machine member that the torque be applied to the piston rod end of the cylinder that is directly attaching to the machine member with the opposite end unrestrained. If the design of the machine is such that only the rod end of the cylinder opposite to where the rod attaches to the machine member can be rotated, consult the factory for further instructions.

### 3.2 Mounting Recommendations

**3.2.1** – Always mount cylinders using the largest possible high tensile alloy steel socket head screws that can fit in the cylinder mounting holes and torque them to the manufacturer's recommendations for their size.

**3.2.2** – Side-Mounted Cylinders – In addition to the mounting bolts, cylinders of this type should be equipped with thrust keys or dowel pins located so as to resist the major load.

**3.2.3** – Tie Rod Mounting – Cylinders with tie rod mountings are recommended for applications where mounting space is limited. The standard tie rod extension is shown as BB in dimension tables. Longer or shorter extensions can be supplied. Nuts used for this mounting style should be torqued to the same value as the tie rods for that bore size.

**3.2.4** – Flange Mount Cylinders – The controlled diameter of the rod gland extension on head end flange mount cylinders can be used as a pilot to locate the cylinders in relation to the machine. After alignment has been obtained, the flanges may be drilled for pins or dowels to prevent shifting.

**3.2.5** – Trunnion Mountings – Cylinders require lubricated bearing blocks with minimum bearing clearances. Bearing blocks should be carefully aligned and rigidly mounted so the trunnions will not be subjected to bending moments. The rod end should also be pivoted with the pivot pin in line and parallel to axis of the trunnion pins.

**3.2.6** – Clevis Mountings – Cylinders should be pivoted at both ends with centerline of pins parallel to each other. After cylinder is mounted, be sure to check to assure that the cylinder is free to swing through its working arc without interference from other machine parts.

### 4.0 Cylinder and Accessories Maintenance, Troubleshooting and Replacement

**4.1 Storage** – At times cylinders are delivered before a customer is ready to install them and must be stored for a period of time. When storage is required the following procedures are recommended.

**4.1.1** – Store the cylinders in an indoor area which has a dry, clean and noncorrosive atmosphere. Take care to protect the cylinder from both internal corrosion and external damage.

**4.1.2** – Whenever possible cylinders should be stored in a vertical position (piston rod up). This will minimize corrosion due to possible condensation which could occur inside the cylinder. This will also minimize seal damage.

**4.1.3** – Port protector plugs should be left in the cylinder until the time of installation.

**4.1.4** – If a cylinder is stored full of hydraulic fluid, expansion of the fluid due to temperature changes must be considered. Installing a check valve with free flow out of the cylinder is one method.

**4.1.5** – When cylinders are mounted on equipment that is stored outside for extended periods, exposed unpainted surfaces, e.g. piston rod, must be coated with a rust-inhibiting compound to prevent corrosion.

#### 4.2 Cylinder Trouble Shooting

##### 4.2.1 – External Leakage

**4.2.1.1** – Rod seal leakage can generally be traced to worn or

damaged seals. Examine the piston rod for dents, gouges or score marks, and replace piston rod if surface is rough.

Rod seal leakage could also be traced to gland wear. If clearance is excessive, replace rod bushing and seal. Rod seal leakage can also be traced to seal deterioration. If seals are soft or gummy or brittle, check compatibility of seal material with lubricant used if air cylinder, or operating fluid if hydraulic cylinder. Replace with seal material, which is compatible with these fluids. If the seals are hard or have lost elasticity, it is usually due to exposure to temperatures in excess of 165°F. (+74°C). Shield the cylinder from the heat source to limit temperature to 350°F. (+177°C.) and replace with fluorocarbon seals.

**4.2.1.2** – Cylinder body seal leak can generally be traced to loose tie rods. Torque the tie rods to manufacturer's recommendation for that bore size.

Excessive pressure can also result in cylinder body seal leak. Determine maximum pressure to rated limits. Replace seals and retorque tie rods as in paragraph above. Excessive pressure can also result in cylinder body seal leak. Determine if the pressure rating of the cylinder has been exceeded. If so, bring the operating pressure down to the rating of the cylinder and have the tie rods replaced.

Pinched or extruded cylinder body seal will also result in a leak. Replace cylinder body seal and retorque as in paragraph above.

Cylinder body seal leakage due to loss of radial squeeze which shows up in the form of flat spots or due to wear on the O.D. or I.D. – Either of these are symptoms of normal wear due to high cycle rate or length of service. Replace seals as per paragraph above.

##### 4.2.2 – Internal Leakage

**4.2.2.1** – Piston seal leak (by-pass) 1 to 3 cubic inches per minute leakage is considered normal for piston ring construction. Virtually no static leak with lipseal type seals on piston should be expected. Piston seal wear is a usual cause of piston seal leakage. Replace seals as required.

**4.2.2.2** – With lipseal type piston seals excessive back pressure due to over-adjustment of speed control valves could be a direct cause of rapid seal wear. Contamination in a hydraulic system can result in a scored cylinder bore, resulting in rapid seal wear. In either case, replace piston seals as required.

**4.2.2.3** – What appears to be piston seal leak, evidenced by the fact that the cylinder drifts, is not always traceable to the piston. To make sure, it is suggested that one side of the cylinder piston be pressurized and the fluid line at the opposite port be disconnected. Observe leakage. If none is evident, seek the cause of cylinder drift in other component parts in the circuit.

##### 4.2.3 – Cylinder Fails to Move the Load

**4.2.3.1** – Pneumatic or hydraulic pressure is too low. Check the pressure at the cylinder to make sure it is to circuit requirements.

**4.2.3.2** – Piston Seal Leak – Operate the valve to cycle the cylinder and observe fluid flow at valve exhaust ports at end of cylinder stroke. Replace piston seals if flow is excessive.

**4.2.3.3** – Cylinder is undersized for the load – Replace cylinder with one of a larger bore size.

##### 4.3 Erratic or Chatter Operation

**4.3.1** – Excessive friction at rod gland or piston bearing due to load misalignment – Correct cylinder-to-load alignment.

**4.3.2** – Cylinder sized too close to load requirements – Reduce load or install larger cylinder.

**4.3.3** – Erratic operation could be traced to the difference between static and kinetic friction. Install speed control valves to provide a back pressure to control the stroke.

##### 4.4 Cylinder Modifications, Repairs, or Failed Component

Cylinders as shipped from the factory are not to be disassembled and or modified. If cylinders require modifications, these modifications must be done at company locations or by the Company's certified facilities. The Cylinder Division Engineering Department must be notified in the event of a mechanical fracture or permanent deformation of any cylinder component (excluding seals). This includes a broken piston rod, tie rod, mounting accessory or any other cylinder component. The notification should include all operation and application details. This information will be used to provide an engineered repair that will prevent recurrence of the failure.

It is allowed to disassemble cylinders for the purpose of replacing seals or seal assemblies. However, this work must be done by strictly following all the instructions provided with the seal kits.

The items described in this document and other documents and descriptions provided by Parker Hannifin Corporation, its subsidiaries and its authorized distributors ("Seller") are hereby offered for sale at prices to be established by Seller. This offer and its acceptance by any customer ("Buyer") shall be governed by all of the following Terms and Conditions. Buyer's order for any item described in its document, when communicated to Seller verbally, or in writing, shall constitute acceptance of this offer. All goods, services or work described will be referred to as "Products".

**1. Terms.** All sales of Products by Seller will be governed by, and are expressly conditioned upon Buyer's assent to, these Terms. These Terms are incorporated into any Quote provided by Seller to Buyer. Buyer's order for any Products whether communicated to Seller verbally, in writing, by electronic data interface or other electronic commerce, shall constitute acceptance of these Terms. Seller objects to any contrary or additional terms or conditions of Buyer. Reference in Seller's order acknowledgement to Buyer's purchase order or purchase order number shall in no way constitute an acceptance of any of Buyer's terms or conditions of purchase. Any Quote made by Seller to Buyer shall be considered a firm and definite offer and shall not be deemed to be otherwise despite any language on the face of the Quote. Seller reserves all rights to accept or reject any purported acceptance by Buyer to Seller's Quote if such purported acceptance attempts to vary the terms of the Quote. If Seller ships Products after Buyer issues an acceptance to the Quote, any additional or different terms proposed by Buyer will not become part of the parties' business relationship unless agreed to in a writing that is signed by an authorized representative of Seller, excluding email correspondence. If the transaction proceeds without such agreement on the part of Seller, the business relationship will be governed solely by these Terms and the specific terms in Seller's Quote.

**2. Price; Payment.** The Products set forth in the Quote are offered for sale at the prices indicated in the Quote. Unless otherwise specifically stated in the Quote, prices are valid for thirty (30) days and do not include any sales, use, or other taxes or duties. Seller reserves the right to modify prices for any reason and at any time by giving ten (10) days prior written notice. Unless otherwise specified by Seller, all prices are F.C.A. Seller's facility (INCOTERMS 2020). All sales are contingent upon credit approval and full payment for all purchases is due thirty (30) days from the date of invoice (or such date as may be specified in the Quote). Under any circumstances, Buyer may not withhold or suspend payment of any amounts due and payable as a deduction, set-off or recoupment of any amount, claim or dispute with Seller. Unpaid invoices beyond the specified payment date incur interest at the rate of 1.5% per month or the maximum allowable rate under applicable law. Seller reserves the right to require advance payment or provision of securities for first and subsequent deliveries if there is any doubt, in Seller's sole determination, regarding the Buyer's creditworthiness or for other business reasons. If the requested advance payment or securities are not provided to Seller's satisfaction, Seller reserves the right to suspend performance or reject the purchase order, in whole or in part, without prejudice to Seller's other rights or remedies, including the right to full compensation. Seller may revoke or shorten any payment periods previously granted in Seller's sole determination. The rights and remedies herein reserved to Seller are cumulative and in addition to any other or further rights and remedies available at law or in equity. No waiver by Seller of any breach by Buyer of any provision of these terms will constitute a waiver by Seller of any other breach of such provision.

**3. Shipment; Delivery;** Title and Risk of Loss. All delivery dates are approximate, and Seller is not responsible for damages or additional costs resulting from any delay. All deliveries are subject to our ability to procure materials from our suppliers. Regardless of the manner of shipment, delivery occurs and title and risk of loss or damage pass to Buyer, upon placement of the Products with the carrier at Seller's facility. Unless otherwise agreed prior to shipment and for domestic delivery locations only, Seller will select and arrange, at Buyer's sole expense, the carrier and means of delivery. When Seller selects and arranges the carrier and means of delivery, freight and insurance costs for shipment to the designated delivery location will be prepaid by Seller and added as a separate line item to the invoice. Buyer shall be responsible for any additional shipping charges incurred by Seller due to Buyer's acts or omissions. Buyer shall not return or repackage any Products without the prior written authorization from Seller, and any return shall be at the sole cost and expense of Buyer.

**4. Warranty.** The warranty for the Products is as follows: (i) Goods are warranted against defects in material or workmanship for a period of eighteen (18) months from the date of delivery or 2,000 hours of use, whichever occurs first; (ii) Services shall be performed in accordance with generally accepted practices and using the degree of care and skill that is ordinarily exercised and customary in the field to which the Services pertain and are warranted for a period of six (6) months from the date of completion of the Services; and (iii) Software is only warranted to perform in accordance with applicable specifications provided by Seller to Buyer for ninety (90) days from the date of delivery or, when downloaded by a Buyer or end-user, from the date of the initial download. All prices are based upon the exclusive limited warranty stated above, and upon the following disclaimer: **EXEMPTION CLAUSE; DISCLAIMER OF WARRANTY, CONDITIONS, REPRESENTATIONS; THIS WARRANTY IS THE SOLE AND ENTIRE WARRANTY, CONDITION, AND REPRESENTATION, PERTAINING TO PRODUCTS. SELLER DISCLAIMS ALL OTHER WARRANTIES, CONDITIONS, AND REPRESENTATIONS, WHETHER STATUTORY, EXPRESS OR IMPLIED, INCLUDING BUT NOT LIMITED TO THOSE RELATING TO DESIGN, NONINFRINGEMENT, MERCHANTABILITY, AND FITNESS FOR A PARTICULAR PURPOSE. SELLER DOES NOT WARRANT THAT THE SOFTWARE IS ERROR-FREE OR FAULT-TOLERANT, OR THAT BUYER'S USE THEREOF WILL BE SECURE OR UNINTERRUPTED, UNLESS OTHERWISE AUTHORIZED IN WRITING BY SELLER, THE SOFTWARE SHALL NOT BE USED IN CONNECTION WITH HAZARDOUS OR HIGH-RISK ACTIVITIES OR ENVIRONMENTS. EXCEPT AS EXPRESSLY STATED HEREIN, ALL PRODUCTS ARE PROVIDED "AS IS".**

**5. Claims; Commencement of Actions.** Buyer shall promptly inspect all Products upon receipt. No claims for shortages will be allowed unless reported to Seller within ten (10) days of delivery. Buyer shall notify Seller of any alleged breach of warranty within thirty (30) days after the date the non-conformance is or should have been discovered by Buyer. Any claim or action against Seller based upon breach of contract or any other theory, including tort, negligence, or otherwise must be commenced within twelve (12) months from the date of the alleged breach or other alleged event, without regard to the date of discovery.

**6. LIMITATION OF LIABILITY. IN THE EVENT OF A BREACH OF WARRANTY, SELLER WILL, AT ITS OPTION, REPAIR OR REPLACE THE NON-CONFORMING PRODUCTS, RE-PERFORM THE SERVICES, OR REFUND THE PURCHASE PRICE PAID WITHIN A REASONABLE PERIOD OF TIME. IN NO EVENT IS SELLER LIABLE FOR ANY SPECIAL, INDIRECT, INCIDENTAL OR CONSEQUENTIAL DAMAGES INCLUDING ANY LOSS OF REVENUE OR PROFITS, WHETHER BASED IN CONTRACT, TORT OR OTHER LEGAL THEORY. IN NO EVENT SHALL SELLER'S LIABILITY UNDER ANY CLAIM MADE BY BUYER EXCEED THE PURCHASE PRICE PAID FOR THE PRODUCTS.**

**7. Confidential Information.** Buyer acknowledges and agrees that Confidential Information has been and will be received in confidence and will remain the property of Seller. Buyer further agrees that it will not use Seller's Confidential Information for any purpose other than for the benefit of Seller and shall return all such Confidential Information to Seller within thirty (30) days upon request.

**8. Loss to Buyer's Property.** Buyer's Property will be considered obsolete and may be destroyed by Seller after two (2) consecutive years have elapsed without Buyer ordering the Products manufactured using Buyer's Property. Also, Seller shall not be responsible for any loss or damage to Buyer's Property while it is in Seller's possession or control.

**9. Special Tooling.** Seller may impose a tooling charge for any Special Tooling. Special Tooling shall be and remain Seller's property. In no event will Buyer acquire any interest in the Special Tooling, even if such Special Tooling has been specially converted or adapted for manufacture of Goods for Buyer and notwithstanding any charges paid by Buyer. Unless otherwise agreed, Seller has the right to alter, discard or otherwise dispose of any Special Tooling or other property owned by Seller in its sole determination at any time.

**10. Security Interest.** To secure payment of all sums due from Buyer, Seller retains a security interest in all Products delivered to Buyer, and Buyer's acceptance of these Terms is deemed to be a Security Agreement under the Uniform Commercial Code. Buyer authorizes Seller as its attorney to execute and file on Buyer's behalf all documents Seller deems necessary to perfect Seller's security interest.

**11. User Responsibility.** Buyer, through its own analysis and testing, is solely responsible for making the final selection of the Products and assuring that all performance, endurance, maintenance, safety and warning requirements of the application of the Products are met. Buyer must analyze all aspects of the application and follow applicable industry standards, specifications, and any technical information provided with the Quote or the Products, such as Seller's instructions, guides and specifications. If Seller provides options of or for Products based upon data or specifications provided by Buyer, Buyer is responsible for determining that such data and specifications are suitable and sufficient for all applications and reasonably foreseeable uses of the Products. In the event Buyer is not the end-user of the Products, Buyer will ensure such end-user complies with this paragraph.

**12. Use of Products, Indemnity by Buyer.** Buyer shall comply with all instructions, guides and specifications provided by Seller with the Quote or the Products. If Buyer uses or resells the Products in any way prohibited by Seller's instructions, guides or specifications, or Buyer otherwise fails to comply with Seller's instructions, guides and specifications, Buyer acknowledges that any such use, resale, or non-compliance is at Buyer's sole risk. Further, Buyer shall indemnify, defend, and hold Seller harmless from any losses, claims, liabilities, damages, lawsuits, judgments and costs (including attorney fees and defense costs), whether for personal injury, property damage, intellectual property infringement or any other claim, arising out of or in connection with: (a) improper selection, design, specification, application, or any misuse of Products; (b) any act or omission, negligent or otherwise, of Buyer; (c) Seller's use of Buyer's Property; (d)

damage to the Products from an external cause, repair or attempted repair by anyone other than Seller, failure to follow instructions, guides and specifications provided by Seller, use with goods not provided by Seller, or opening, modifying, deconstructing, tampering with or repackaging the Products; or (e) Buyer's failure to comply with these Terms, including any legal or administrative proceedings, collection efforts, or other actions arising from or relating to such failure to comply. Seller shall not indemnify Buyer under any circumstance except as otherwise provided in these Terms.

**13. Cancellations and Changes.** Buyer may not cancel or modify, including but not limited to movement of delivery dates for the Products, any order for any reason except with Seller's written consent and upon terms that will indemnify, defend and hold Seller harmless against all direct, incidental and consequential loss or damage and any additional expense. Seller, at any time, may change features, specifications, designs and availability of Products.

**14. Assignment.** Buyer may not assign its rights or obligations without the prior written consent of Seller.

**15. Force Majeure.** Seller is not liable for delay or failure to perform any of its obligations by reason of any events or circumstances beyond its reasonable control. Such circumstances include without limitation: accidents, labor disputes or stoppages, government acts or orders, acts of nature, pandemics, epidemics, other widespread illness, or public health emergency, cyber related disruptions, cyber-attacks, ransomware sabotage, delays or failures in delivery from carriers or suppliers, shortages of materials, sudden increases in the price of raw material or components, shutdowns or slowdowns affecting the supply of raw materials or components, or the transportation thereof, oil shortages or oil price increases, energy crisis, energy or fuel interruption, war (whether declared or not) or the serious threat of same, riots, rebellions, acts of terrorism, embargoes, fire or any reason whether similar to the foregoing or otherwise. Seller will resume performance as soon as practicable after the event of force majeure has been removed. All delivery dates affected by an event of force majeure shall be tolled for the duration of such event of force majeure and rescheduled for mutually agreed dates as soon as practicable after the event of force majeure ceases to exist. The right to allocate capacity is in the Seller's sole discretion. An event of force majeure shall not include financial distress, insolvency, bankruptcy, or other similar conditions affecting one of the parties, affiliates and/or sub-contractors. An event of force majeure in the meaning of these Terms means any circumstances beyond Seller's control that permanently or temporarily hinders performance, even where that circumstance was already foreseen. Buyer shall not be entitled to cancel any orders following its claim of an event of force majeure.

**16. Waiver and Severability.** Failure to enforce any provision of these Terms will not invalidate that provision; nor will any such failure prejudice either party's right to enforce that provision in the future. Invalidation of any provision of these Terms shall not invalidate any other provision herein and, the remaining provisions will remain in full force and effect.

**17. Duration.** Unless otherwise stated in the Quote, any agreement governed by or arising from these Terms shall: (a) be for an initial duration of one (1) year; and (b) shall automatically renew for successive one-year terms unless terminated by Buyer with at least 180-days written notice to Seller or if Seller terminates the agreement pursuant to Section 19 of these Terms.

**18. Termination.** Seller may, without liability to Buyer, terminate any agreement governed by or arising from these Terms for any reason and at any time by giving Buyer thirty (30) days prior written notice. Seller may immediately terminate, in writing, if Buyer: (a) breaches any provision of these Terms, (b) becomes or is deemed insolvent, (c) appoints or has appointed a trustee, receiver or custodian for all or any part of Buyer's property, (d) files a petition for relief in bankruptcy on its own behalf, or one is filed against Buyer by a third party, (e) makes an assignment for the benefit of creditors; or (f) dissolves its business or liquidates all or a majority of its assets.

**19. Ownership of Rights.** Buyer agrees that (a) Seller (and/or its affiliates) owns or is the valid licensee of Seller's IP and (b) the furnishing of information, related documents or other materials by Seller to Buyer does not grant or transfer any ownership interest or license in or to Seller's IP to Buyer, unless expressly agreed in writing. Without limiting the foregoing, Seller retains ownership of all Software supplied to Buyer. In no event shall Buyer obtain any greater right in and to the Software than a right in a license limited to the use thereof and subject to compliance with any other terms provided with the Software. Buyer further agrees that it will not, directly or through intermediaries, reverse engineer, decompile, or disassemble any Software (including firmware) comprising or contained within a Product, except and only to the extent that such activity may be expressly permitted, either by applicable law or, in the case of open source software, the applicable open source license.

**20. Indemnity for Infringement of Intellectual Property Rights.** Seller is not liable for infringement of any Intellectual Property Rights except as provided in this Section. Seller will defend at its expense and will pay the cost of any settlement or damages awarded in an action brought against Buyer based on a third-party claim that one or more of the Products infringes the Intellectual Property Rights of a third party in the country of delivery of the Products by Seller to Buyer. Seller's obligation to defend and indemnify Buyer is contingent on Buyer notifying Seller within ten (10) days after Buyer becomes aware of any such claim, and Seller having sole control over the defense of the claim including all negotiations for settlement or compromise. If one or more Products is subject to such a claim, Seller may, at its sole expense and option, procure for Buyer the right to continue using the Products, replace or modify the Products to render them non-infringing, or offer to accept return of the Products and refund the purchase price less a reasonable allowance for depreciation. Seller has no obligation or liability for any claim of infringement: (i) arising from information provided by Buyer (including Seller's use of Buyer's Property), or (ii) directed to any Products for which the designs are specified in whole or part by Buyer, or (iii) resulting from the modification, combination or use in a system of any Products. The foregoing provisions of this Section constitute Seller's sole and exclusive liability and Buyer's sole and exclusive remedy for claims of infringement of Intellectual Property Rights.

**21. Governing Law.** These Terms, the terms of any Quote, and the sale and delivery of all Products are deemed to have taken place in, and shall be governed and construed in accordance with, the laws of the State of Ohio, as applicable to contracts executed and wholly performed therein and without regard to conflicts of laws principles. Buyer irrevocably agrees and consents to the exclusive jurisdiction and venue of the courts of Cuyahoga County, Ohio with respect to any dispute, controversy or claim arising out of or relating to the sale and delivery of the Products.

**22. Entire Agreement.** These Terms, along with the terms set forth in the Quote, forms the entire agreement between the Buyer and Seller and constitutes the final, complete and exclusive expression of the terms of sale and purchase. In the event of a conflict between any term set forth in the Quote and these Terms, the terms set forth in the Quote shall prevail. All prior or contemporaneous written or oral agreements or negotiations with respect to the subject matter shall have no effect. No modification to these Terms will be binding on Seller unless agreed to in a writing that is signed by an authorized representative of Seller, excluding email correspondence, "clickwrap" or other purported electronic assent to different or additional terms. Sections 2-25 of these Terms shall survive termination or cancellation of any agreement governed by or arising from these Terms.

**23. No 'Wrap' Agreements/No Authority to Bind.** Seller's clicking any buttons or any similar action, such as clicking "I Agree" or "Confirm," to utilize Buyer's software or webpage for the placement of orders, is NOT an agreement to Buyer's Terms and Conditions. NO EMPLOYEE, AGENT OR REPRESENTATIVE OF SELLER HAS THE AUTHORITY TO BIND SELLER BY THE ACT OF CLICKING ANY BUTTON OR SIMILAR ACTION ON BUYER'S WEBSITE OR PORTAL.

**24. Compliance with Laws.** Buyer agrees to comply with all applicable laws, regulations, and industry and professional standards, including those of the United States of America, and the country or countries in which Buyer may operate, including without limitation the U.S. Foreign Corrupt Practices Act ("FCPA"), the U.S. Anti-Kickback Act ("Anti-Kickback Act"), U.S. and E.U. export control and sanctions laws ("Export Laws"), the U.S. Food Drug and Cosmetic Act ("FDCA"), and the rules and regulations promulgated by the U.S. Food and Drug Administration ("FDA"), each as currently amended. Buyer agrees to indemnify, defend, and hold harmless Seller from the consequences of any violation of such laws, regulations and standards by Buyer, its employees or agents. Buyer represents that it is familiar with all applicable provisions of the FCPA, the Anti-Kickback Act, Export Laws, the FDCA and the FDA and certifies that Buyer will adhere to the requirements thereof and not take any action that would make Seller violate such requirements. Buyer represents and agrees that Buyer will not make any payment or give anything of value, directly or indirectly, to any governmental official, foreign political party or official thereof, candidate for foreign political office, or commercial entity or person, for any improper purpose, including the purpose of influencing such person to purchase Products or otherwise benefit the business of Seller. Buyer further represents and agrees that it will not receive, use, service, transfer or ship any Products from Seller in a manner or for a purpose that violates Export Laws or would cause Seller to be in violation of Export Laws. Buyer agrees to promptly and reliably provide Seller all requested information or documents, including end-user statements and other written assurances, concerning Buyer's ongoing compliance with Export Law. 9/22





# Parker's Motion & Control Technologies

At Parker, we're guided by a relentless drive to help our customers become more productive and achieve higher levels of profitability by engineering the best systems for their requirements. It means looking at customer applications from many angles to find new ways to create value. Whatever the motion and control technology need, Parker has the experience, breadth of product and global reach to consistently deliver. No company knows more about motion and control technology than Parker. For further info call 1 800 C-Parker (1 800 272 7537)



## Aerospace

### Key Markets

Aftermarket services  
Commercial transports  
Engines  
General & business aviation  
Helicopters  
Launch vehicles  
Military aircraft  
Missiles  
Power generation  
Regional transports  
Unmanned aerial vehicles

### Key Products

Control systems & actuation products  
Engine systems & components  
Fluid conveyance systems & components  
Fluid metering, delivery & atomization devices  
Fuel systems & components  
Fuel tank inerting systems  
Hydraulic systems & components  
Thermal management  
Wheels & brakes



## Climate Control

### Key Markets

Agriculture  
Air conditioning  
Construction Machinery  
Food & beverage  
Industrial machinery  
Life sciences  
Oil & gas  
Precision cooling  
Process  
Refrigeration  
Transportation

### Key Products

Accumulators  
Advanced actuators  
CO<sub>2</sub> controls  
Electronic controllers  
Filter driers  
Hand shut-off valves  
Heat exchangers  
Hose & fittings  
Pressure regulating valves  
Refrigerant distributors  
Safety relief valves  
Smart pumps  
Solenoid valves  
Thermostatic expansion valves



## Electromechanical

### Key Markets

Aerospace  
Factory automation  
Life science & medical  
Machine tools  
Packaging machinery  
Paper machinery  
Plastics machinery & converting  
Primary metals  
Semiconductor & electronics  
Textile  
Wire & cable

### Key Products

AC/DC drives & systems  
Electric actuators, gantry robots & slides  
Electrohydraulic actuation systems  
Electromechanical actuation systems  
Human machine interface  
Linear motors  
Stepper motors, servo motors, drives & controls  
Structural extrusions



## Filtration

### Key Markets

Aerospace  
Food & beverage  
Industrial plant & equipment  
Life sciences  
Marine  
Mobile equipment  
Oil & gas  
Power generation & renewable energy  
Process  
Transportation  
Water Purification

### Key Products

Analytical gas generators  
Compressed air filters & dryers  
Engine air, coolant, fuel & oil filtration systems  
Fluid condition monitoring systems  
Hydraulic & lubrication filters  
Hydrogen, nitrogen & zero air generators  
Instrumentation filters  
Membrane & fiber filters  
Microfiltration  
Sterile air filtration  
Water desalination & purification filters & systems



## Fluid & Gas Handling

### Key Markets

Aerial lift  
Agriculture  
Bulk chemical handling  
Construction machinery  
Food & beverage  
Fuel & gas delivery  
Industrial machinery  
Life sciences  
Marine  
Mining  
Mobile  
Oil & gas  
Renewable energy  
Transportation

### Key Products

Check valves  
Connectors for low pressure fluid conveyance  
Deep sea umbilicals  
Diagnostic equipment  
Hose couplings  
Industrial hose  
Mooring systems & power cables  
PTFE hose & tubing  
Quick couplings  
Rubber & thermoplastic hose  
Tube fittings & adapters  
Tubing & plastic fittings



## Hydraulics

### Key Markets

Aerial lift  
Agriculture  
Alternative energy  
Construction machinery  
Forestry  
Industrial machinery  
Machine tools  
Marine  
Material handling  
Mining  
Oil & gas  
Power generation  
Refuse vehicles  
Renewable energy  
Truck hydraulics  
Turf equipment

### Key Products

Accumulators  
Cartridge valves  
Electrohydraulic actuators  
Human machine interfaces  
Hybrid drives  
Hydraulic cylinders  
Hydraulic motors & pumps  
Hydraulic systems  
Hydraulic valves & controls  
Hydrostatic steering  
Integrated hydraulic circuits  
Power take-offs  
Power units  
Rotary actuators  
Sensors



## Pneumatics

### Key Markets

Aerospace  
Conveyor & material handling  
Factory automation  
Life science & medical  
Machine tools  
Packaging machinery  
Transportation & automotive

### Key Products

Air preparation  
Brass fittings & valves  
Manifolds  
Pneumatic accessories  
Pneumatic actuators & grippers  
Pneumatic valves & controls  
Quick disconnects  
Rotary actuators  
Rubber & thermoplastic hose & couplings  
Structural extrusions  
Thermoplastic tubing & fittings  
Vacuum generators, cups & sensors



## Process Control

### Key Markets

Alternative fuels  
Biopharmaceuticals  
Chemical & refining  
Food & beverage  
Marine & shipbuilding  
Medical & dental  
Microelectronics  
Nuclear Power  
Offshore oil exploration  
Oil & gas  
Pharmaceuticals  
Power generation  
Pulp & paper  
Steel  
Water/wastewater

### Key Products

Analytical Instruments  
Analytical sample conditioning products & systems  
Chemical injection fittings & valves  
Fluoropolymer chemical delivery fittings, valves & pumps  
High purity gas delivery fittings, valves, regulators & digital flow controllers  
Industrial mass flow meters/ controllers  
Permanent no-weld tube fittings  
Precision industrial regulators & flow controllers  
Process control double block & bleeds  
Process control fittings, valves, regulators & manifold valves



## Sealing & Shielding

### Key Markets

Aerospace  
Chemical processing  
Consumer  
Fluid power  
General industrial  
Information technology  
Life sciences  
Microelectronics  
Military  
Oil & gas  
Power generation  
Renewable energy  
Telecommunications  
Transportation

### Key Products

Dynamic seals  
Elastomeric o-rings  
Electro-medical instrument design & assembly  
EMI shielding  
Extruded & precision-cut, fabricated elastomeric seals  
High temperature metal seals  
Homogeneous & inserted elastomeric shapes  
Medical device fabrication & assembly  
Metal & plastic retained composite seals  
Shielded optical windows  
Silicone tubing & extrusions  
Thermal management  
Vibration dampening

ENGINEERING YOUR SUCCESS.

Parker Hannifin Corporation  
**Cylinder and Accumulator Division**  
500 South Wolf Road  
Des Plaines, IL 60016  
phone (847) 298-2400  
fax (800) 892-1008  
[www.parker.com/cylinder-accumulator](http://www.parker.com/cylinder-accumulator)

