



FL20-SA series

Power Range 220V 0.05kW~4.5kW
380V/400V 1.0kW~37kW

Product Manual (English)

Version: N2018051801

aerospace
climate control
electromechanical
filtration
fluid & gas handling
hydraulics
pneumatics
process control
sealing & shielding



ENGINEERING YOUR SUCCESS.

FAILURE OR IMPROPER SELECTION OR IMPROPER USE OF THE PRODUCTS
DESCRIBED HEREIN OR RELATED ITEMS CAN CAUSE DEATH, PERSONAL
INJURY AND PROPERTY DAMAGE.

This document and other information from Parker-Hannifin Corporation, its subsidiaries and authorized distributors provide product or system options for further investigation by users having technical expertise.

The user, through its own analysis and testing, is solely responsible for making the final selection of the system and components and assuring that all performance, endurance, maintenance, safety and warning requirements of the application are met. The user must analyze all aspects of the application, follow applicable industry standards, and follow the information concerning the product in the current product catalog and in any other materials provided from Parker or its subsidiaries or authorized distributors.

To the extent that Parker or its subsidiaries or authorized distributors provide component or system options based upon data or specifications provided by the user, the user is responsible for determining that such data and specifications are suitable and sufficient for all applications and reasonably foreseeable uses of the components or systems



FL20-SA series

2018 Parker Hannifin Manufacturing Ltd.

All rights strictly reserved. No part of this document may be stored in a retrieval system, or transmitted in any form or by any means to persons not employed by a Parker SSD Drives company without written permission from Parker Automation Wuxi, a division of Parker Hannifin Ltd . Although every effort has been taken to ensure the accuracy of this document it may be necessary, without notice, to make amendments or correct omissions. Parker Automation Wuxi cannot accept responsibility for damage, injury, or expenses resulting therefrom.

WARRANTY

Refer to Parker Hannifin Manufacturing Limited Terms and Conditions of Sale. These documents are available on request at www.parker.com/ADC. Parker Hannifin Manufacturing Limited reserves the right to change the content and product specification without notice.

About this manual

■ Description of technical terms

The terms in this manual are defined as follows:

Servodrive is used to drive and control servo motor.

Servo System means a servo control system that includes the combination of a servodrive, servo motor with a host computer and peripheral devices.

Parameters include monitoring parameter and setting parameters. Monitoring parameters can only be checked, but not be modified, and setting parameters can be checked and modified, which includes function parameters and data parameters.

■ Common symbol

The following symbols are used for convenience.

1. Instruction

P: position mode	Pt: position pulse mode	ALL: all modes
	Pr: internal register position mode	
S: speed mode	Sr: internal register speed mode	
	Sz: analog speed mode	
T: torque mode	Tr: internal register torque mode	
	Tz: analog torque mode	

2. Usage of backslash (/)

Backslash is used in the wiring diagram. It describes the default logic of I/O interface.

For input signal (DI terminal), backslash means, when input circuit is ON status, the input signal is valid, i.e. the default logic is positive logic. Without backslash means, when input side is OFF status, the input signal is valid, i.e. the default logic is negative logic.

For output signal (DO terminal), backslash means output side circuit is common-opened, and when the signal is output, the output side circuit is closed. Without backslash means output side circuit is common-closed, and when the signal is output, the output side circuit is opened.

3. Others

NC: no connection

N/A: no unit

I	NOTES FOR SAFE OPERATION	11
II	MODEL SELECTION	15
2.1	SERVO DRIVE INTRODUCTION.....	15
2.1.1	SERVO DRIVE NAMEPLATE.....	15
2.1.2	CONNECTION TO PERIPHERAL DEVICES	17
2.1.3	SERVO DRIVE SPECIFICATION.....	18
2.1.4	CONNECTION TO PERIPHERAL DEVICES	21
2.2	SERVO MOTOR.....	22
2.2.1	SERVO MOTOR NAMEPLATE AND MODEL.....	22
2.2.2	SERVO MOTOR COMPONENT	23
2.2.3	SERVO MOTOR MODEL.....	24
2.3	COMBINATION OF SERVOMOTOR AND SERVODRIVE.....	27
2.4	INPUT FILTER MODEL AND DIMENSIONS	30
III	INSTALLATION	36
3.1	SERVO DRIVES INSTALLATION.....	36
3.1.1	INSTALLATION CONDITIONS.....	36
3.1.2	INSTALLATION PROCEDURE AND MINIMUM CLEARANCES	37
3.1.3	SERVO DRIVE DIMENSION	38
3.2	SERVO MOTOR INSTALLATION.....	44
3.2.1	INSTALLATION LOCATION	44
3.2.2	INSTALLATION CONDITIONS	44
3.2.3	PRECAUTIONS ON SERVO MOTOR INSTALLATION.....	45
3.2.4	SERVO MOTOR DIMENSION	46
IV	WIRING	52
4.1	MAIN CIRCUIT WIRING.....	54
4.1.1	MAIN CIRCUIT TERMINALS	54
4.1.2	MAIN CIRCUIT TERMINAL WIRING	55
4.1.3	TYPICAL MAIN CIRCUIT WIRING EXAMPLES	56
4.1.4	PRECAUTION FOR MAIN CIRCUIT WIRING	58
4.2	ENCODER WIRING.....	59
4.2.1	ABSOLUTE ENCODER CONNECTOR TERMINAL LAYOUT	59
4.2.2	RESOLVER ENCODER CONNECTOR TERMINAL LAYOUT.....	60

4.2.3 INCREMENTAL ENCODER CONNECTOR TERMINAL LAYOUT.....	61
4.3 I/O SIGNAL WIRING	62
4.3.1 POSITION COMMAND INPUT SIGNAL AND FUNCTION	64
4.3.2 ANALOG COMMAND INPUT SIGNAL AND FUNCTIONS.....	69
4.3.3 ANALOG OUTPUT SIGNAL AND FUNCTIONS	69
4.3.4 DIGITAL INPUT SIGNAL AND FUNCTIONS	70
4.3.5 ENCODER FREQUENCY-DIVISION OUTPUT SIGNAL AND FUNCTION	73
4.3.6 COMMUNICATION WIRING	74
4.3.7 WIRING WHEN USING MORE THAN ONE SERVOS.....	75
4.3.8 ABSOLUTE VALUE ENCODER.....	77
4.4 SERVO DRIVE AND SERVO MOTOR WIRING	78
4.4.1 ENCODER WIRING.....	78
4.4.2 POWER CABLE OF SERVO DRIVE AND SERVO MOTOR.....	81
4.5 EMC	82
4.5.1 DEFINITION	82
4.5.2 INSTALLATION ENVIRONMENT	82
4.5.3 SELECTION AND INSTALLATION OF PERIPHERAL EMC DEVICES.....	83
4.5.4 SHIELDED CABLE	83
V. OPERATION AND PARAMETERS.....	85
5.1 KEYPAD DESCRIPTION	85
5.2 KEYPAD OPERATING PROCEDURE	86
5.2.2 PARAMETERS INSTRUCTIONS.....	87
5.3 KEYPAD OPERATING PROCEDURE.....	89
5.3.1 EXAMPLE OF MONITOR FUNCTION PARAMETER	89
5.3.2 EXAMPLE OF AUXILIARY PARAMETERS USAGE.....	90
5.3.3 PARAMETER SETTING	91
6.1 BASIC PARAMETERS SETTING	97
6.1.1 BEFORE RUNNING.....	97
6.1.2 POWER ON	97
6.1.3 PARAMETERS SETTING.....	97
6.1.4 SETTING THE OVERTRAVEL LIMIT FUNCTION	101
6.1.5 JOG OPERATION PROCEDURE	104
6.1.6 TIMING SEQUENCE CONTROL.....	105
6.1.7 SETTING THE BRAKING	107

6.2 SPEED MODE	110
6.2.1 PARAMETERS SETTING.....	110
6.2.1 PARAMETERS SETTING.....	111
6.2.2 SOFT START	118
6.2.3 S CURVE SMOOTHNESS FUNCTION	119
6.2.4 ZERO CLAMP FUNCTION	120
6.2.5 SPEED OUTPUT SIGNAL	120
6.3 TORQUE MODE.....	124
6.3.1 PARAMETERS SETTING	124
6.3.2 SOFT START	130
6.3.3 SPEED LIMITING AT TORQUE MODE.....	131
6.3.4 LIMITING TORQUE	131
6.3.5 RELATED OUTPUT.....	133
6.4 POSITION PULSE MODE	133
6.4.1 PARAEMETERS SETTING.....	134
6.4.2 SETTING ELECTRONIC GEAR	150
6.4.3 POSITION COMMAND FILTER.....	153
6.4.4 SOFT START OF POSITION COMMAND	153
6.4.5 POSITION COMMAND INHIBIT FUNCTION.....	154
6.4.6 COMMAND PULSE CLEAR FUNCTION.....	154
6.4.7 FREQUENCY-DIVISION OUTPUT FUNCTION	155
6.4.8 HOMESEARCHMODE.....	159
6.4.9MECHANICAL ORIGIN SEARCH FUNCTION	165
6.4.10 FIXED LENGTH INTERRUPT FUNCTION	167
6.4.11 DO OUTPUT RELATED TO POSITION PULSE	169
6.4.12 FULL CLOSED LOOP FUNCTION	171
6.4.13 GANTRY SYCHRON FUNCTION	175
6.4.14 ELECTRONIC CAM (E-CAM) FUNCTION.....	179
6.5 DUAL MODE.....	190
6.5.1 USER PARAMETER SETTING.....	190
6.5.2 INTERNAL SPEED AND POSITION PULSE DUAL MODE	191
6.5.3 ANALOG SPEED AND POSITION PULSE DUAL MODE.....	192
6.5.4 ANALOG SPEED AND INTERNAL REGISTER POSITION DUAL MODE.....	193
6.5.5 INTERNAL SPEED AND INTERNAL REGISTER POSITION DUAL MODE.....	194
6.5.6 TOREQUE MODE AND POSITION PULSE DUAL MODE.....	195

6.5.7 TORQUE MODE AND INTERNAL REGISTER POSITION DUAL MODE	196
6.5.8 POSITION PULSE AND INTERNAL REGISTER POSITION DUAL MODE.....	197
6.5.9 INTERNAL SPEED AND ANALOG SPEED DUAL MODE	198
6.5.10 SPEED AND TORQUE DUAL MODE	199
6.5.11 ANALOG TORQUE AND INTERNAL REGISTER TORQUE DUAL MODE	201
6.6 AUXILIARY FUNCTION.....	202
6.6.1 SETTING PASSWORD	202
6.6.2 SERVO DRIVE STATUS DISPLAY.....	203
6.6.3 FAN SETTING.....	204
6.6.4 PARAMETER COPY	204
6.6.5 REVERTING TO MFR'S VALUE.....	205
6.6.6 MOTOR PROTECTION FUNCTION	205
6.6.7 ENCODER PULSE FILTERING.....	207
6.6.8 TORQUE UNREACHED PROTECTION CONTROL.....	207
6.6.9 DI TERMINALS FILTER FUNCTION.....	207
6.6.10 COGGING TORQUE COMPENSATION.....	208
6.6.11 FRICTION TORQUE COMPENSATION.....	2088
6.6.12 OTHER OUTPUT SIGNALS	2089
6.7 HIGH-SPEED COUNTER FUNCTION	212
6.7.1 OVERVIEW.....	212
6.7.2 HIGH-SPEED COUNTING.....	212
6.8 BUILT-IN PLC FUNCTION	218
6.8.1 SUMMARY	218
6.8.2 SERVO BUILT-IN PLC SOFTWARE ACCESS AREA.....	219
6.8.3 BUILT-IN PLC PROGRAM DESIGN.....	224
6.8.3.1 DATA MOVE INSTRUCTION	224
6.8.3.2 ARITHMETIC INSTRUCTION.....	225
6.8.3.3 LOGIC INSTRUCTION	233
6.8.3.4 PROGRAM CONTROL INSTRUCTION	237
6.8.4 BUILT-IN PLC PARAMETERS.....	242
6.8.5 BUILT-IN PC/PLC USE AND APPLICATION EXAMPLE.....	246
6.8.6 BUILT-IN PLC COMMUNICATION OPERATION	251
6.8.6.1 MODBUS ADDRESS	251
6.8.6.2 DEBUG FUNCTION OF BUILT-IN PLC	251

VII. ADJUSTMENTS	252
7.1 SUMMARY	252
7.2 INERTIA IDENTIFICATION	253
7.2.1 OFFLINE INERTIA IDENTIFICATION.....	253
7.2.2 ONLINE INERTIA IDENTIFICATION.....	255
7.3 GAIN ADJUSTMENT	257
7.3.1 SUMMARY	257
7.3.2 AUTOMATIC GAIN ADJUSTMENT	258
7.3.3 MANUAL GAIN ADJUSTMENT	260
7.3.4 GAIN SWITCH.....	262
7.4 VIBRATION INHIBITION.....	265
7.4.1 VIBRATION INHIBITION FUNCTION	265
7.4.2 LOW-FREQUENCY VIBRATION INHIBITION FUNCTION.....	266
VIII LIST OF PARAMETERS	267
8.1.1 MONITOR FUNCTION GROUP (Lo-□□)	267
8.1.2 UTILITY FUNCTION GROUP (So-□□)	270
8.1.3 MAIN FUNCTION GROUP (Po-□□□)	278
8.1.4 MOTOR FUNCTION GROUP (Ho-□□□)	309
8.1.5 ALARM RECORD PARAMETERS (Ho2□□~Ho3□□)	311
8.1.6 HIGH-SPEED COUNTER PARAMETERS (PL□□□)	314
IX MAINTENANCE AND INSPECTION	329
9.1 ALARM AND TROUBLE SHOOTING AT START.....	329
9.1.1 POSITION CONTROL MODE	329
9.1.2 SPEED CONTROL MODE.....	331
9.1.3 TORQUE CONTROL MODE.....	332
9.2 ALARM CODE AND POSSIBLE CAUSE	333
9.3 ALARM DISPLAY TABLE AND TROUBLE SHOOTING	334
9.3.1 OTHER MALFUNCTIONS.....	338
X COMMUNICATION	339
10.1 COMMUNICATION.....	339
10.1.1 MODBUS GENERAL.....	339
10.1.2 MODBUS PROTOCOL.....	339

10.1.3 PARAMETER RELATED TO COMMUNICATION	343
XI APPENDIX.....	345
11.1 ENCODER CABLE SELECTION	345
11.1.1 ABSOLUTE ENCODER CABLE	345
11.1.2 INCREMENTAL ENCODER CABLE	346
11.1.3 RESOLVER ENCODER CABLE	347
11.2 CONTROL CABLE	347
11.3 POWER CABLE	348
11.4 OTHER CABLE	349
11.5 MOTOR AND MATCHED CABLE	349
XII APPENDIX 2	352
12.1 ETHERCAT COMMUNICATION CARD	352
12.1.1 INSTALLATION AND CONNECTION	354
12.1.2 HARDWARE LAYOUT	355
12.1.3 TOPOLOGY WAY	355
12.1.4 LED INDICATOR	356
12.1.5 DIAL SWITCH SW2	356
12.1.6 SERVO RELATED PARAMETER SETTING	356
12.2 CANOPEN COMMUNICATION CARD	357
12.2.1 INSTALLATION AND CONNECTION	358
12.2.2 HARDWARE LAYOUT.....	359
12.2.3 CAN-BUS CONNECTION	359
12.2.4 CANOPEN BUS INTERFACE PINS	359
12.2.5 STATUS INDICATOR	360
12.2.6 SWITCH CODE.....	361
12.2.7 SERVO RELATED PARAMETER SETTING	361

I Notes for safe operation

Read this manual thoroughly before checking products on delivery, storage and transportation, installation, wiring, operation and inspection, and disposal of the servo drives.



WARNING

- Do not touch terminals for five minutes after voltage resistance test.
- Do not touch terminals for five minutes after the power is turned off. Residual voltage may cause electric shock.
- Never touch any rotating motor parts while the motor is running.
- Never touch the inside of the SERVOPACKs.
- Follow the procedures and instructions for trial operation precisely as described in this manual.
- Do not remove the front cover, cables, connectors, or optional items while the power is ON.
- Do not damaged, press, exert excessive force or place heavy objects on the cables.
- Do not change the max speed value (Po002) except special purpose. Failure to observe this warning may result in damaged to products.
- Do not come close to the machine Immediate after resetting momentary power loss to avoid an unexpected restart. Take appropriate measures to ensure safety against an unexpected restart.
- Do not modify products. Failure to observe this warning may result in injury or damage to products.
- MCtt (electromagnetic contactor) and NFB (no fuse breaker) must be installed between main circuit power (L1/R, L2/S, L3/T for 3-phase).

Storage and Transportation**CAUTION**

·Do not store or install the product in the following places:

1. Locations subject to direct sunlight.
2. Locations subject to temperatures outside the range specified in the storage or installation temperature conditions.
3. Locations subject to humidity outside the range specified in the storage or installation temperature conditions.
4. Locations subject to corrosive or flammable gases.
5. Locations subject to dust, salts or iron dust.
6. Locations subject to exposure to water, oil, or chemicals.
7. Locations subject to shock or vibration.

·Do not hold the product by the cables or motor shaft while transporting it.

·Do not place any load exceeding the limit specified on the packing box.

·Requirements of waste products disposal meet local laws and regulations.

Installation**CAUTION**

- Never use the products in an environment subject to water, corrosive gases, inflammable gases, or combustibles.
- Do not step on or place a heavy object on the product.
- Do not cover the inlet or outlet ports and prevent any foreign objects from entering the product.
- Be sure to install the product in the correct direction.
- Provide the specified clearances between the SERVOPACK and the control panel or with other devices.
- Do not apply any strong impact.

Wiring**CAUTION**

- Do not connect a three-phase power supply to the U, V, or W output terminals.
- Connect U, V and W of servo drive directly to U, V, and W of servo motor, avoid using contactor in between.
- Securely connect the power supply terminals and motor output terminals.
- Do not connect servo drive for 220V directly to 400V voltage.
- Do not bundle or run power and signal lines together in the same duct. Keep power and signal lines separated by at least 30 cm.
- Use twisted-pair shielded wires or multi-core twisted pair shielded wires for signal and encoder cables.
- The maximum length is 3m for reference input lines and the maximum length is 20m for encoder cables.
- Take appropriate and sufficient countermeasures for each form of potential interference when installing systems in the following locations.
 - Locations subjects to static electricity or other forms of noise.
 - Locations subjects to strong electromagnetic fields and magnetic fields.
 - Locations subjects to possible exposure to radioactivity.
- Repair or maintain the servo drive only after the CHARGE indication on the servo drive goes off.

Maintenance and Inspection**CAUTION**

- Repair or maintenance of the servo drive can be performed only by qualified personnel.
- Please cut off all connection between servo drive with resistor before performing an insulation test of resistor.
- When replacing the servo drive, resume operation only after transferring the previous servo drive parameters to the new servo drive or computer.
- Do not attempt to change wiring while the power is ON.
- Do not disassemble the servo motor.

II Model selection

2.1 Servo drive introduction

2.1.1 Servo Drive Nameplate

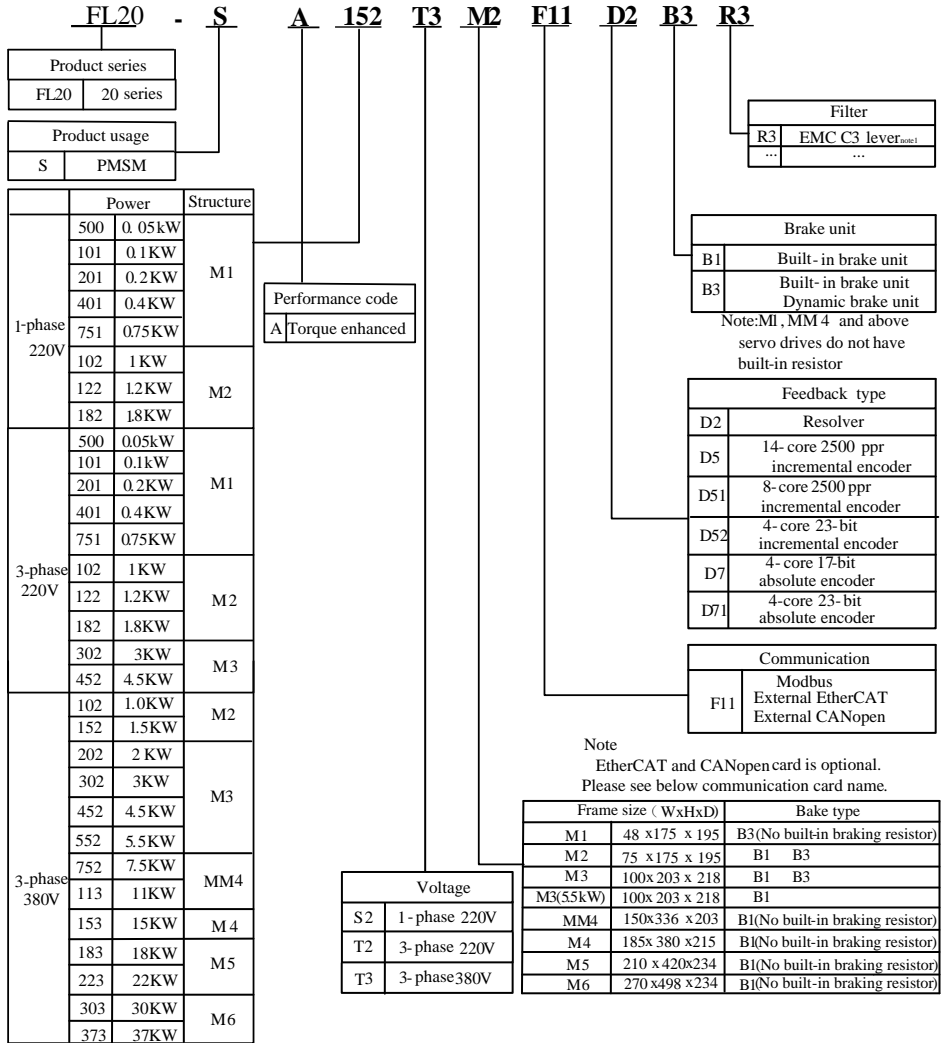

Fig 2.1.1 Servo Drive naming rule

Note 1: For M1-MM4 structure, R3 is external filter, please refer to chapter 2.4 for external filter model. For M4-M6 structure, R3 is optional built-in filter.

Communication card	
20S-0006	EtherCAT
20S-0007	CANopen

Fig 2.1.2 Optional function naming rule

		Parker Hannifin Corporation		<small>www.parker.com</small>
Model	FL20-SA202T3M3	Function code	F11D5B3	
Input	AC 3 PH	380 V	50 / 60 Hz	
Output	AC 3 PH	6 A	0 ~ 380V	
	0~400Hz	Matched motor	FMMA - 202F67ED	
BAR CODE				

Fig 2.1.3 Servo Drive nameplate

2.1.2 Connection to Peripheral Devices

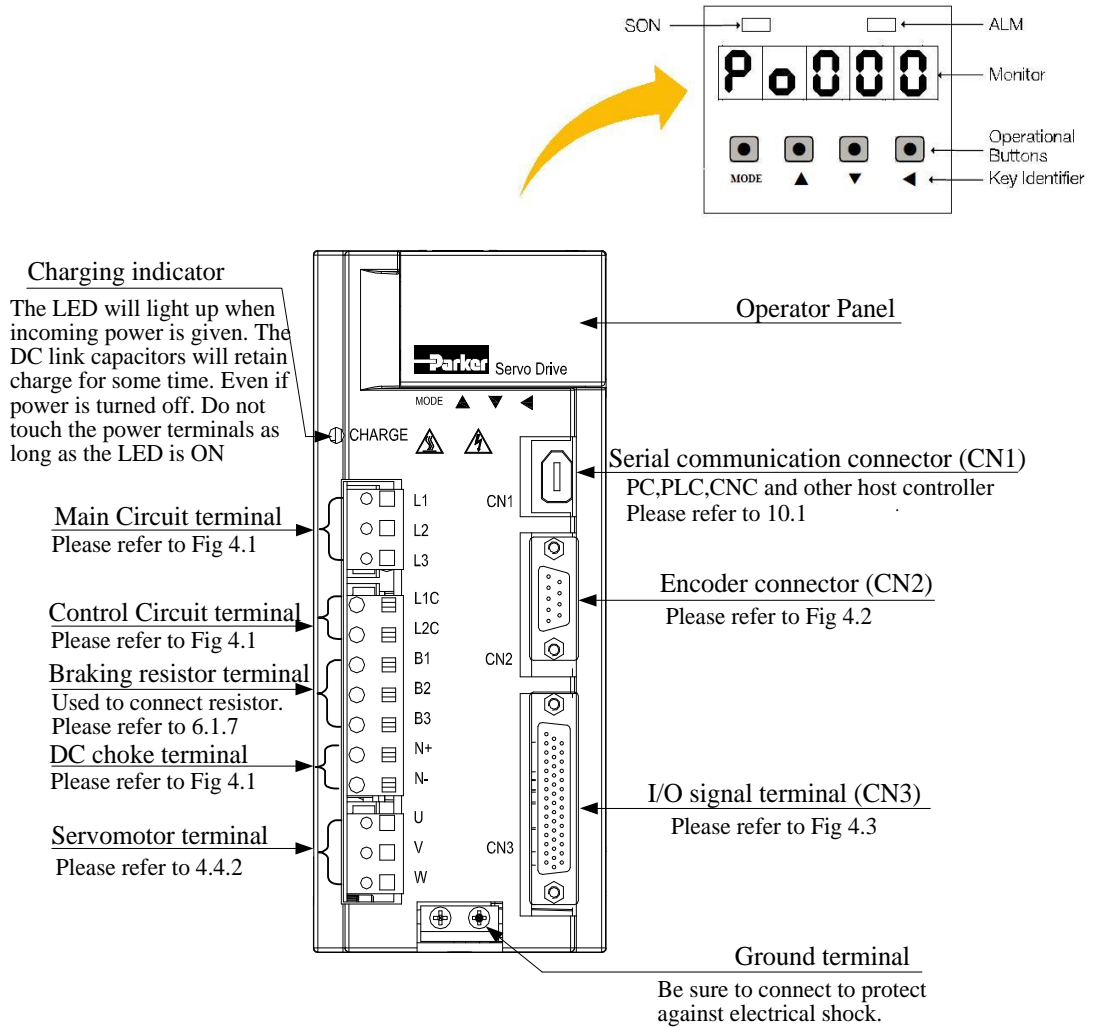

Fig 2.1.4 Connection to Peripheral Devices

2.1.3 Servo drive specification

1) Electrical specification

a) 220V servo drive

Name	M1					M2			M3	
Servo drive FL20-SA	500	101	201	401	751	102	122	182	302	452
Continuous output current Arms	0.6	1.2	1.5	2.8	3.5	4.5	6.0	8.0	12	17
Max output current Arms	1.8	3.6	4.2	8.4	9.8	12.6	16.8	22.4	33.6	47.6
Power of main circuit	1-phase/3-phase AC 220V -15~+10% 50/60Hz									
Power of control circuit	1-phase/3-phase AC 220V -15~+10% 50/60Hz									
Braking type	External braking resistor					Built-in braking resistor.				

b) 380V/400V servo drive

Name	M2		M3				MM4		M4	M5		M6	
Servo drive FL20-SA	102	152	202	302	452	552	752	113	153	183	223	303	373
Continuous output current Arms	3	3.5	6.0	8.0	10. 0	12.0	20	23	32	38	44	60	75
Max output current Arms	8.4	9.8	16	19. 2	28	33	56	64	80	95	110	150	187
Power of main circuit	1-phase/3-phase AC 380V -10~+10% 50/60Hz												
Power of control circuit	Without control circuit												
Braing type	Built-in braking resistor.							External braking resistor					

2) Technical specification

A. Basic specifications

Items		Contents
Power supply	S2/T2	220VAC -15~+10% 50/60Hz
	T3	380/400VAC -10~+10% 50/60Hz

Control mode		Pt Position pulse mode Pr Internal register position mode _ Sz Analog speed mode Sr Internal register speed mode Tz Analog torque mode Tr Internal register torque mode
Regenerative braking		Built-in or External (External braking should be selected and purchased)
Control characteristic	Control mode	PMSM
	Frequency response	1.2KHz
	Speed fluctuation	±0.01% (VC, load fluctuation 0 to 100%)
	Speed control range	1: 10000
	Input pulse frequency	1. 500KHz (differential drive); 200KHz (Open collector) 2. At high-speed pulse circuit, receiving frequency is 4MHZ.(Differential)
Input signal	Control input	Servo on, Alarm reset, Pulse clear, Pulse prohibited, Forward run prohibited, Reverse run prohibited, Forward torque limit, Reverse torque limit, Internal speed selection, Internal position triggered, "Home" searching triggered, Zero speed CLAMP
	Speed Feedback	1. Absolute encoder. 2. Incremental encoder. 3. Resolver
Output signal	Control output	Servo ready, Servo alarm activated, At positioning completed, At speed reached, Electromagnetic brake control, Rotation Detection, At speed limit, Homing completed, At torque limit, and so on.
	Encoder signal frequency-division output	1. Encoder Z phase open-collector output. 2. Encoder signal output (A, B Z Line Driver) frequency-division output 3. Z pulse time extend function.
Position control	Input mode	1. A phase+B phase 2. Forward pulse+Reverse pulse 3. Pulse+Direction 4. Internal register
	Electronic gear	1. $0.01 \leq B / A \leq 100$ 2. Two groups electronic gear can be selected by users.
Analog speed control		-10V~+10V analog speed signal input, the voltage scope can be set by function code.
Analog torque control		-10V~+10V analog torque signal input, the voltage scope can be set by function code.
Acceleration/Deceleration		Accele/decele time is set to 1~30000ms(related to 0←→rated speed)
Communication		1. RS485 communication port is connected with PC, to set control parameters and to monitor servo. 2. CANopen or EtherCAT can be selected as option.
Parameters setting	Keypad	The parameters are set by keypad, which is displayed by 5LEDs.
	PC/PLC	RS485 communication can set parameters by some PC/PLC software.
Monitor function		Output current, PN voltage, motor speed, motor feedback pulse, motor feedback rotation, given pulse, given pulse error, given speed, given torque, analog speed given and analog torque given.
Protection function		Overvoltage, Undervoltage, Overload, Overcurrent, Encoder error, Overspeed, Abnormal pulse control command, Emergency stop, Servo

FL20-SA Series

	overheat, Input power phase loss, Regeneration error, Overposition.
Applicable load inertia	Lower than 5 times of servo motor inertia.

B. Performance index

Control mode	Specification			
Speed mode	Soft start	0~30S (Acceleration time and deceleration time can be set).		
	Input signal	Input voltage	DC±10V/ rated speed (It is default setting, which can be changed by function code)	
		Input impedance	About 50K	
		Circuit time parameter	About 52us	
Internal register speed	3 kinds of speed are combined by SD-S1 and SD-S2, the running direction is controlled by SD-DIR (positive/negative logic is set by function code).			
Position mode	Specification	Feedforward compensation	0~100% (resolution is 1%)	
		Positional accuracy	1 command unit	
	Input signal	Pulse form	Select one from “direction +pulse” or “90° phase difference orthogonal pulse”, or“forward pulse + reverse pulse”.	
		Input form	Differential input, open-collector input.	
		Input pulse frequency	1. Optocoupler input Differential driver: max frequency is 500KHZ; Collector driver: max frequency is 200KHZ; 2. Differential chip input, the max frequency is 4MHZ	
		Electronical gear	$0.01 \leq B/A \leq 100$	
	Output signal	Output form	A phase, B phase, Z phase: differential driver output Z phase open collector output.	
		Frequency-division ratio	A, B phase frequency-division output except Z phase	
	Control signal	Pulse command clear	Bias pulse can be cleared by external signal.	
	Built-in power	+24V (100mA)		
Torque mode	Input signal	Input voltage	DC±10V/ rated torque (It is default setting, which can be changed by function code)	
		Input impedance	About 50K	
		Circuit time parameter	About 52us	

2.1.4 Connection to Peripheral Devices

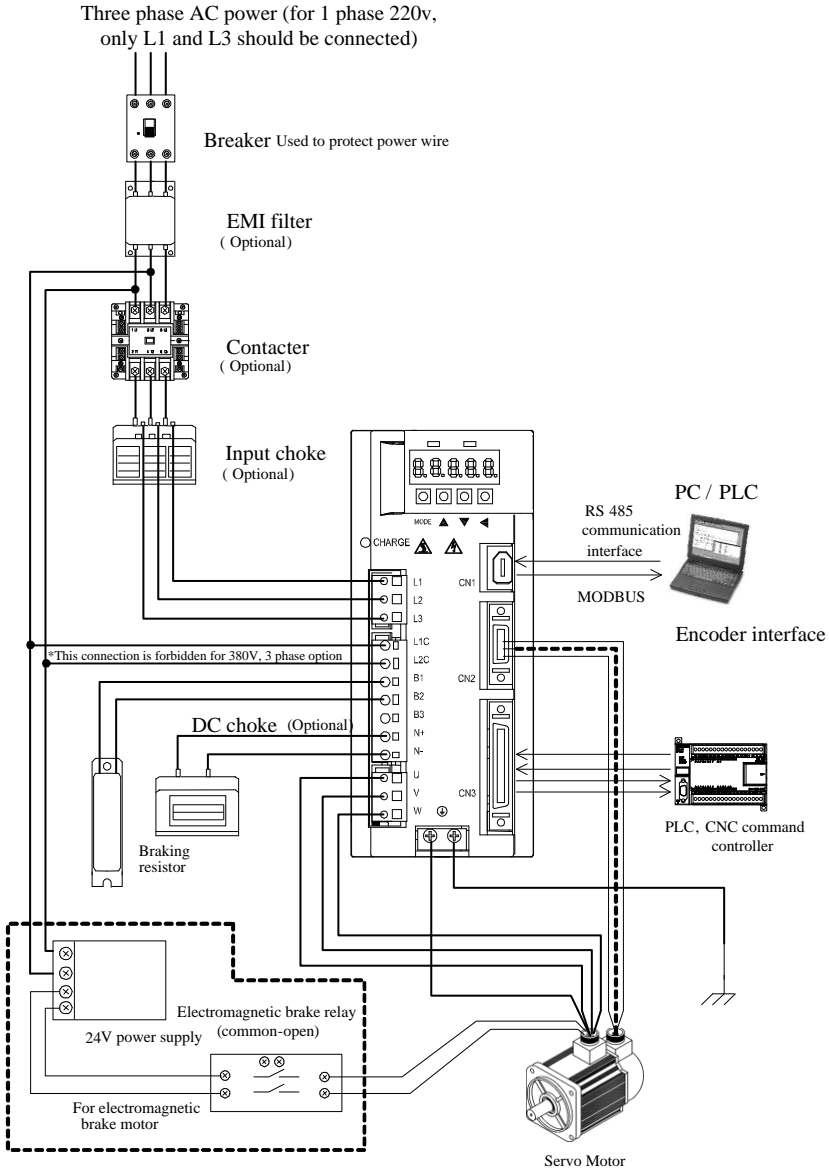

Fig 2.1.5 Servo drive system

Note)

For 220V input servo drive, L1C and L2C should be connected to power supply.

For 380V input servo drive, L1C and L2C are forbidden to connect.

2.2 Servo motor

2.2.1 Servo motor nameplate and model

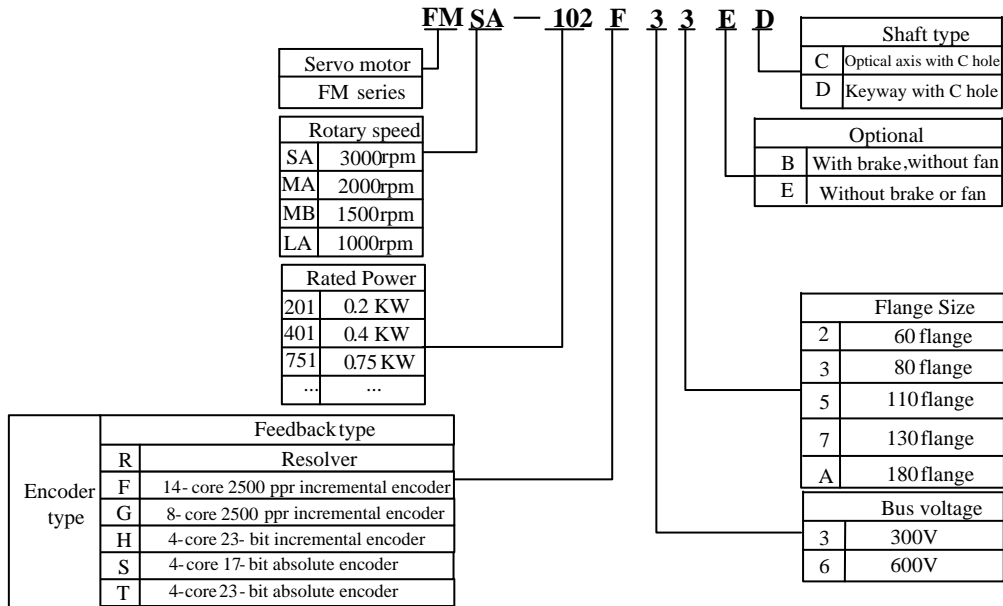

Fig 2.2.1 Servo motor naming rule (for 180 flange and below 180 flange motor)

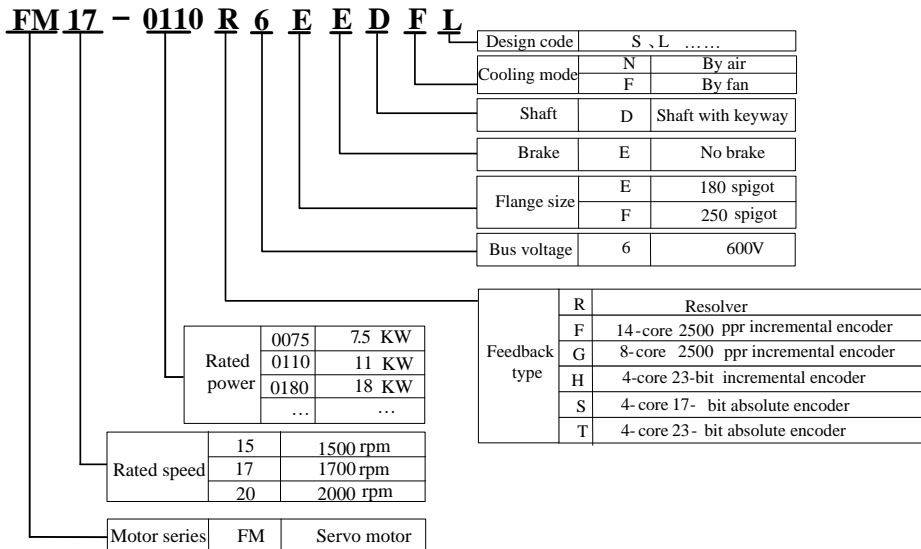

Fig 2.2.2 Servo motor naming rule (for 180 spigot and 250 spigot motor)

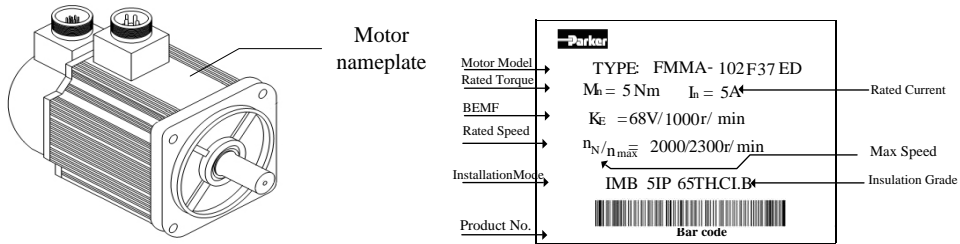

Fig2.2.3 Servo motor naming rule (for 180 flange and below 180 flange motor)

FM17-0110R6EEDFL		
Ph :11kw	Un :380V	Tn :64 N.m
Nn: 1700r/min	In :23A	Fan voltage: 220V
TH CI F IP54	No.:	
Magnetic Field Angle:	Date:	
 AC permanent magnetic synchronous servo motor		

Fig 2.2.4 Servo motor naming rule (for 180 spigot and 250 spigot motor)

【note】

1. Please refer to the chapter in the 《3.2.4 servo motor dimension》 for flange dimension.
2. 11KW and above 11kw servo motor can be mounted by flange and base, user can choose mounting method according to requirement.

2.2.2 Servo motor component

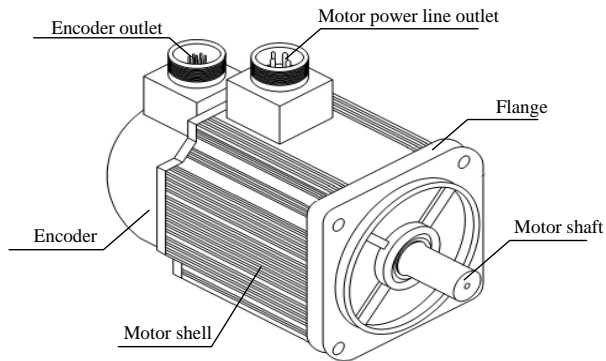

Fig 2.2.5 Name of part of servo motor

2.2.3 Servo motor model

1) 220V motor model

Motor model ^{note}		Rated power	Rated torque	Rated current	Rotation inertia
		W	N·m	A	10 ⁻⁴ Kg·m ²
FMS series 3000r/min	FMSA-201*32***	200	0.64	1.2	0.17
	FMSA-401*32***	400	1.27	2.8	0.29
	FMSA-751*33***	750	2.39	3.5	1.82
	FMSA-102*33***	1000	3.5	4.5	2.9
	FMSA-122*35***	1200	4	5	6.9
	FMSA-152*37***	1500	5	7.5	12.2
	FMSA-182*35***	1800	6	8	10.1
	FMSA-232*37***	2300	7.7	10	18.2
	FMSA-302*37***	3000	10	15.5	24.2
FMM series 2000 r/min	FMMA-801*35***	800	4	3.5	6.9
	FMMA-851*37***	850	4	4	10.8
	FMMA-102*37***	1000	5	5	12.2
	FMMA-122*35***	1200	6	5	10.1
	FMMA-132*37***	1300	6	6	15
	FMMA-152*37***	1500	7.7	7.5	18.2
	FMMA-202*37***	2000	10	10	24.2
	FMMA-312*37***	3100	15	14	34.9
	FMMA-352**3A***	3500	17.2	16	55.3
FMM series 1500 r/min	FMMB-122*37***	1200	7.7	5	18.2
	FMMB-152*37***	1500	10	6	24.2
	FMMB-232*37***	2300	14.6	10	34.9
	FMMB-272*3A***	2700	17.2	11	55.3
	FMMB-302*3A***	3000	19	12	66.3
	FMMB-432*3A***	4300	27	16	84.8
FML series 1000 r/min	FMLA-102*37***	1000	10	4.5	24.2
	FMLA-152*37***	1500	14.3	7	34.9
	FMLA-292*3A***	2900	27	12	84.8
	FMLA-372*3A***	3700	35	16	119.5

2) 380V motor model

Motor model ^{note}		Rated power	Rated torque	Rated current	Rotation inertia
		W	N·m	A	10 ⁻⁴ Kg·m ²
FMS series 3000 r/min	FMMSA-751*63***	750	2.39	2	1.82
	FMMSA-102*63***	1000	3.5	3	2.9
	FMMSA-122*65***	1200	4	4	6.9
	FMMSA-152*67***	1500	5	5	12.2
	FMMSA-182*65***	1800	6	6	10.1
	FMMSA-232*67***	2300	7.7	7	18.2
	FMMSA-302*67***	3000	10	8	24.2
FMM series 2000 r/min	FMMA-801*65***	800	4	2.5	6.9
	FMMA-851*67***	850	4	3	10.8
	FMMA-102*67***	1000	5	3	12.2
	FMMA-122*65***	1200	6	3.5	10.1
	FMMA-132*67***	1300	6	3.5	15
	FMMA-152*67***	1500	7.7	4.5	18.2
	FMMA-202*67***	2000	10	5.5	24.2
	FMMA-312*67***	3100	15	9	34.9
	FMMA-352*6A***	3500	17.2	8	55.3
	FMMA-452*6A***	4500	21.5	10	74.8
	FMMA-602*6A***	6000	27	14	84.8
	FMMA-802*6A***	8000	35	18	119.5
FMMA-103*6A***	10000	48	24	133	
FMM series 1500 r/min	FMMB-122*67***	1200	7.7	4	18.2
	FMMB-152*67***	1500	10	4	24.2
	FMMB-232*67***	2300	14.6	6	34.9
	FMMB-302*67***	3000	14.6	7.5	34.9
	FMMB-272*6A***	2700	17.2	8	55.3
	FMMB-302*6A***	3000	19	8	66.3
	FMMB-432*6A***	4300	27	10	84.8
	FMMB-552*6A***	5500	35	12.5	119.5
	FMMB-752*6A***	7500	48	17	133

FL20-SA Series

FML series 1000 r/min	FMLA-102*67***	1000	10	3	24.2
	FMLA-292*6A***	2900	27	7	84.8
	FMLA-372*6A***	3700	35	9	119.5

3) Servo motor of 180 spigot and 250 spigot

Motor model ^{note}		Rated power	Rated torque	Rated current
		KW	N·m	A
FMM series 1500 r/min	FM15-0082*6EE*FL	8.2	52	16.6
	FM15-0100*6EE*FL	10	64	20.7
	FM15-0124*6EE*FL	12.4	80	24.7
	FM15-0160*6EE*FL	16	102	33.5
	FM15-0180*6EE*FL	18	118	40
	FM15-0210*6FE*FL	21	135	43.2
	FM15-0240*6EE*FL	24	152	46.7
	FM15-0290*6FE*FL	29	185	57.5
FMM series 1700 r/min	FM17-0075*6EE*FL	7.5	42	13.7
	FM17-0092*6EE*FL	9.2	52	18
	FM17-0110*6EE*FL	11	64	23
	FM17-0140*6EE*FL	14	80	29.2
	FM17-0180*6EE*FL	18	102	38.5
	FM17-0210*6FE*FL	21	118	45
	FM17-0240*6EE*FL	24	135	48.5
	FM17-0270*6EE*FL	27	152	57.5
FMM series 2000 r/min	FM20-0070*6EE*FL	7	33.6	14.8
	FM20-0100*6EE*FL	10	52	22
	FM20-0140*6EE*FL	14	64	30
	FM20-0180*6EE*FL	18	80	37
	FM20-0220*6EE*FL	22	102	43
	FM20-0250*6EE*FL	25	118	49
	FM20-0280*6EE*FL	28	135	56.9
	FM20-0300*6EE*FL	30	152	67

	FM20-0360*6FE*FL	36	185	74
	FM20-0071*6FEDNL	7.1	34	14.5
	FM20-0094*6EEDNL	9.4	45	18.8
	FM20-0117*6EEDNL	11.7	56	24.4
	FM20-0140F6EEDNL	14	67	28.6

Note: ** represents shaft type and brake type, please refer to the chapter of servo motor naming rule.

2.3 Combination of servomotor and servodrive

1) 220V servo motor and FL20 servo drive

Motor model ^{note}		Power	Adaptable servodrive (Note)		Function code
		W	1 phase220V	3 phase 220V	
FMS series 3000r/min	FMSA-201F/S32***	200	FL20-SA201S2M1	FL20-SA201T2M1	F11D*B*
	FMSA-401F/S32***	400	FL20-SA401S2M1	FL20-SA401T2M1	
	FMSA-751*33***	750	FL20-SA751S2M1	FL20-SA751T2M1	
	FMSA-102*33***	1000	FL20-SA102S2M2	FL20-SA102T2M2	
	FMSA-122*35***	1200	FL20-SA122S2M2	FL20-SA122T2M2	
	FMSA-152*37***	1500	FL20-SA182S2M2	FL20-SA182T2M2	
	FMSA-182*35***	1800			
	FMSA-232*37***	2300	—	FL20-SA302T2M3	
FMSA-302*37***	3000	—	FL20-SA452T2M3		
FMM series 2000r/min	FMMA-801*35***	800	FL20-SA102S2M2	FL20-SA102T2M2	
	FMMA-851*37***	850			
	FMMA-102*37***	1000	FL20-SA122S2M2	FL20-SA122T2M2	
	FMMA-122*35***	1200			
	FMMA-132*37***	1300	FL20-SA182S2M2	FL20-SA182T2M2	
	FMMA-152*37***	1500			
	FMMA-202*37***	2000	—	FL20-SA302T2M3	
	FMMA-312*37***	3100	—	FL20-SA452T2M3	
FMMA-352*3A***	3500	—			
FMM series 1500r/min	FMMB-122*37***	1200	FL20-SA122S2M2	FL20-SA122T2M2	
	FMMB-152*37***	1500	FL20-SA182S2M2	FL20-SA182T2M2	
	FMMB-232*37***	2300	—	FL20-SA302T2M3	
	FMMB-272*3A***	2700	—		
	FMMB-302*3A***	3000	—		
	FMMB-432*3A***	4300	—		FL20-SA452T2M3

FL20-SA Series

FML series 1000r/min	FMLA-102*37***	1000	FL20-SA102S2M2	FL20-SA102T2M2
	FMLA-152*37***	1500	FL20-SA182S2M2	FL20-SA182T2M2
	FMLA-292*3A***	2900	—	FL20-SA302T2M3
	FMLA-372*3A***	3700	—	FL20-SA452T2M3

2) 380V servo motor and FL20 servo drive

Motor model ^{note}		Power	Adaptable servodrive (Note)	
		W	Three-phase 380 v	Function code
FMS series 3000r/min	FMSA-751*63***	750	FL20-SA102T3M2	F11D*B*
	FMSA-102*63***	1000		
	FMSA-122*65***	1200	FL20-SA202T3M3	
	FMSA-152*67***	1500		
	FMSA-182*65***	1800		
	FMSA-232*67***	2300	FL20-SA302T3M3	
	FMSA-302*67***	3000	FL20-SA302T3M3	
FMM series 2000r/min	FMMA-801*65***	800	FL20-SA102T3M2	
	FMMA-851*67***	850		
	FMMA-102*67***	1000		
	FMMA-122*65**	1200	FL20-SA152T3M2	
	FMMA-132*67***	1300		
	FMMA-152*67**	1500	FL20-SA202T3M3	
	FMMA-202*67***	2000		
	FMMA-312*67***	3100		
	FMMA-352*6A***	3500	FL20-SA452T3M3	
	FMMA-452*6A***	4500	FL20-SA752T3MM4	
	FMMA-602*6A***	6000		
	FMMA-802*6A***	8000		
FMMA-103*6A***	10000	FL20-SA153T3M4		
FMM series 1500r/min	FMMB-122*67***	1200	FL20-SA152T3M3	
	FMMB-152*67***	1500	FL20-SA202T3M3	
	FMMB-232*67***	2300		
	FMMB-302*67***	3000	FL20-SA302T3M3	
	FMMB-272*6A***	2700		
	FMMB-302*6A***	3000		

FL20-SA Series

	FMMB-432*6A***	4300	FL20-SA452T3M3
	FMMB-552*6A***	5500	FL20-SA552T3M3
	FMMB-752*6A***	7500	FL20-SA752T3MM4
FML series 1000r/min	FMLA-102*67***	1000	FL20-SA102T3M2
	FMLA-292*6A***	2900	FL20-SA302T3M3
	FMLA-372*6A***	3700	FL20-SA452T3M3
FMM series 1500r/min	FM15-0082*6EE*FL	8200	FL20-SA752T3MM4
	FM15-0100*6EE*FL	10000	FL20-SA113T3MM4
	FM15-0124*6EE*FL	12400	FL20-SA153T3M4
	FM15-0160*6EE*FL	16000	FL20-SA183T3M5
	FM15-0180*6EE*FL	18000	FL20-SA223T3M5
	FM15-0210*6EE*FL	21000	
	FM15-0240*6EE*FL	24000	FL20-SA303T3M6
	FM15-0290*6EE*FL	29000	
FM15-0350*6EE*FL	35000	FL20-SA373T3M6	
FMM series 1700r/min	FM17-0075*6EEDFL	7500	FL20-SA752T3MM4
	FM17-0092*6EE*FL	9200	FL20-SA113T3MM4
	FM17-0110*6EE*FL	11000	
	FM17-0140*6EE*FL	14000	FL20-SA153T3M4
	FM17-0180*6EE*FL	18000	FL20-SA183T3M5
	FM17-0210*6EE*FL	21000	FL20-SA223T3M5
	FM17-0240*6EE*FL	24000	FL20-SA303T3M6
	FM17-0270*6EE*FL	27000	
FM17-0330*6EE*FL	33000	FL20-SA373T3M6	
FMM series 2000r/min	FM20-0070*6EE*FL	7000	FL20-SA752T3MM4
	FM20-0100*6EE*FL	10000	FL20-SA113T3MM4
	FM20-0140*6EE*FL	14000	FL20-SA153T3M4
	FM20-0180*6EE*FL	18000	FL20-SA183T3M5
	FM20-0220*6EE*FL	22000	FL20-SA223T3M5
	FM20-0250*6EE*FL	25000	FL20-SA303T3M6
	FM20-0280*6EE*FL	28000	
	FM20-0300*6EE*FL	30000	FL20-SA373T3M6
FM20-0360*6FE*FL	36000		

FL20-SA Series

	FM20-0071*6FEDNL	7100	FL20-SA752T3MM4	
	FM20-0094*6EEDNL	9400		
	FM20-0117*6EEDNL	11700	FL20-SA153T3M4	
	FM20-0140*6EEDNL	14000		

Note:

- 5.5 kw and above 5.5kw servo drive doesn't have dynamic brake. M1, MM4 structure and above servodrive doesn't have built-in resistor, customer should purchase braking resistor separately.
- R means resolver, F means 14-core 2500ppr incremental encoder, G means 8-core 2500ppr incremental encoder, H means 4-core 23-bit incremental encoder, S means 4-core 17-bit absolute, and T means 4-core 23-bit absolute.
- ** means shaft type and brake type, please refer to the chapter of servo motor naming rule.

2.4 Input filter model and dimensions

FL20 series can supply EMC R3 level filter, the filter of M1-MM4 structure is external, the filter of M4-M6 structure is built-in.

1. Input filter model:

Servo drive model	Filter model (FILTEMC)	Filter model (SCHAFFNER)	Remarks
FL20-SA101S2M1	FT130-6-T2/02.12.205	FN2090NN-6-06	User can select different brand filters according to actual situation.
FL20-SA201S2M1	FT130-6-T2/02.12.205	FN2090NN-6-06	
FL20-SA401S2M1	FT130-6-T2/02.12.205	FN2090NN-10-06	
FL20-SA751S2M1	FT130-10-T2 /02.12.209	FN2090LL-10-06	
FL20-SA102S2M2	FT130-20-T2 /02.12.207	FN2090-20-06	
FL20-SA122S2M2	FT130-20-T2 /02.12.207	FN2090-20-06	
FL20-SA182S2M2	FT130-20-T2 /02.12.207	FN2090-20-06	
FL20-SA101T2M1	FT330-6-T3 /02.17.136	FN3258-7-44	
FL20-SA201T2M1	FT330-6-T3 /02.17.136	FN3258-7-44	
FL20-SA401T2M1	FT330-6-T3 /02.17.136	FN3258-7-44	
FL20-SA751T2M1	FT330-6-T3 /02.17.136	FN3258-7-44	
FL20-SA102T2M2	FT330-10-T3	FN3258-7-44	
FL20-SA122T2M2	FT330-10-T3	FN3258-16-44	
FL20-SA182T2M2	FT330-15-T3	FN3258-16-44	
FL20-SA302T2M3	FT330-20-T3	FN3258-30-33	
FL20-SA452T2M3	FT330-30-T3	FN3258-30-33	

FL20-SA Series

FL20-SA152T3M2	FT330F-6-T3	FN3258-7-44	
FL20-SA202T3M3	FT330F-15-T3	FN3258-16-44	
FL20-SA302T3M3	FT330F-15-T3	FN3258-16-44	
FL20-SA452T3M3	FT330F-20-T3	FN3258-16-44	
FL20-SA552T3M3	FT330F-20-T3	FN3258-30-33	
FL20-SA752T3MM4	FT330F-50-T3	FN3258-42-33	
FL20-SA113T3MM4	FT330F-50-T3	FN3258-42-33	
FL20-SA153T3M4	—	—	Built-in
FL20-SA183T3M5	—	—	Built-in
FL20-SA223T3M5	—	—	Built-in
FL20-SA303T3M6	—	—	Built-in
FL20-SA373T3M6	—	—	Built-in

2. Input filter dimensions.

(1) FT series filter dimension

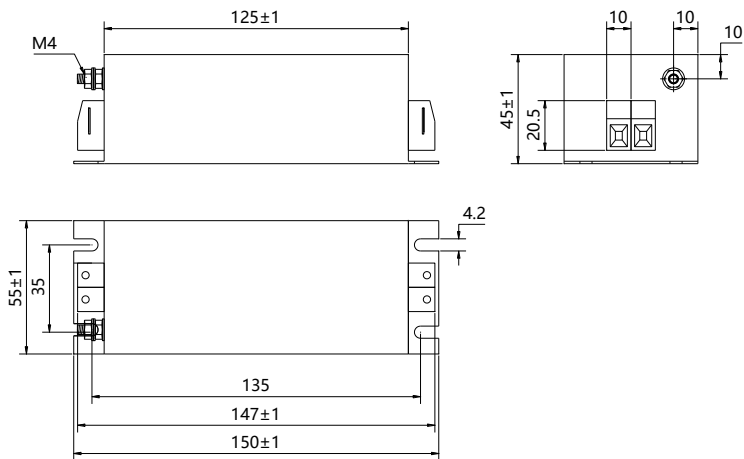

Fig 2.4.1 FT130 series

Model	Remarks
FT130-6-T2	
FT130-10-T2	
FT130-20-T2	

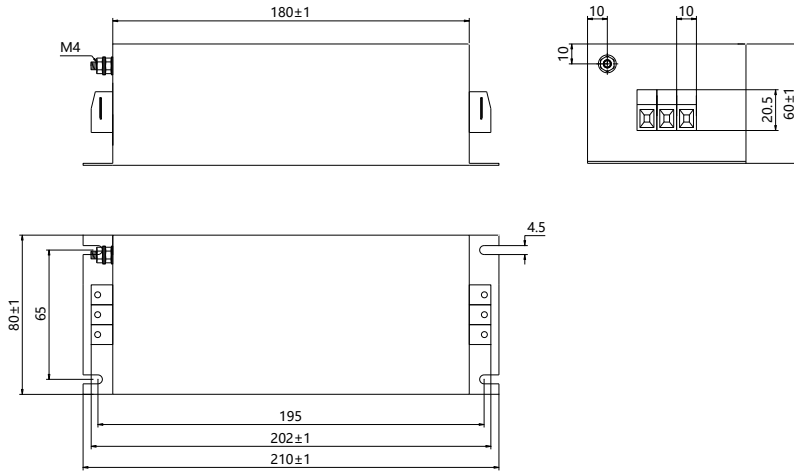

Fig 2.4.2 FT330 series

Model	Remarks
FT330-6-T3	
FT330-15-T3	
FT330F-6-T3	
FT330F-15-T3	
FT330F-20-T3	

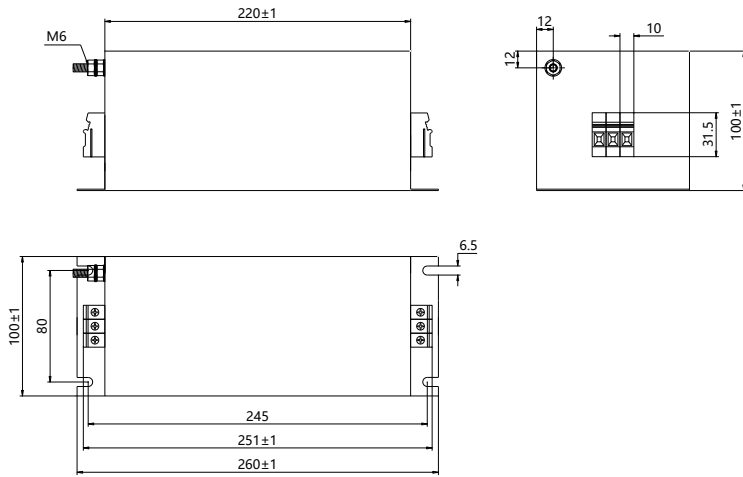

Fig 2.4.3 FT330F series

Model	Remarks
FT330F-50-T3	

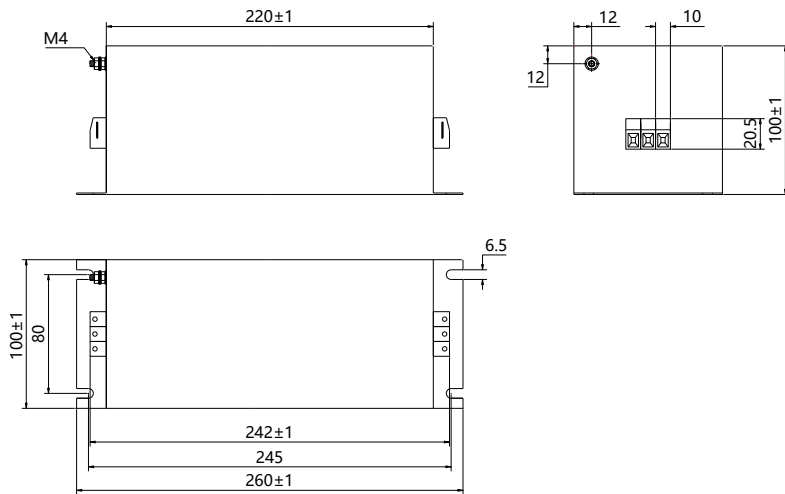

Fig 2.4.4 FT330F series

Model	Remarks
FT330F-30-T3	

(2) FN series filter dimension

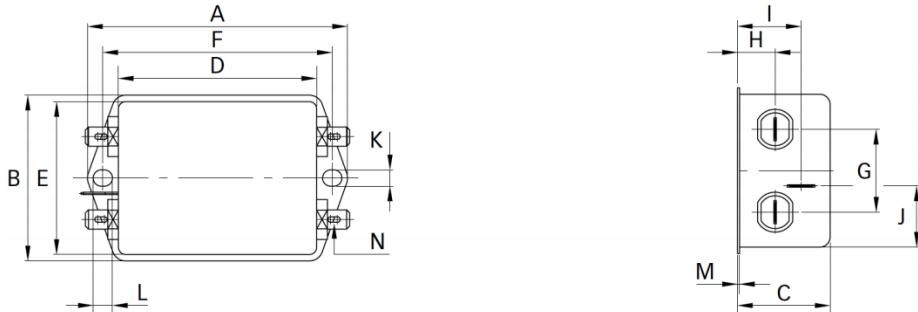

Fig 2.4.5 FN2090 series

	FN2090NN-6-06	FN2090LL-10-06	FN2090-20-06
A	85	113.5±1	113.5±1
B	54	57.5±1	57.5±1
C	30.3	45.4±1	45.4±1
D	64.8	94±1	94±1
E	49.8	56	56
F	75	103	103
G	27	25	25
H	12.3	12.4	12.4
I	20.8	32.4	32.4
J	19.9	15.5	15.5
K	5.3	4.4	4.4
L	6.3	6	6
M	0.7	0.9	0.9
N	6.3X0.8	6.3X0.8	6.3X0.8

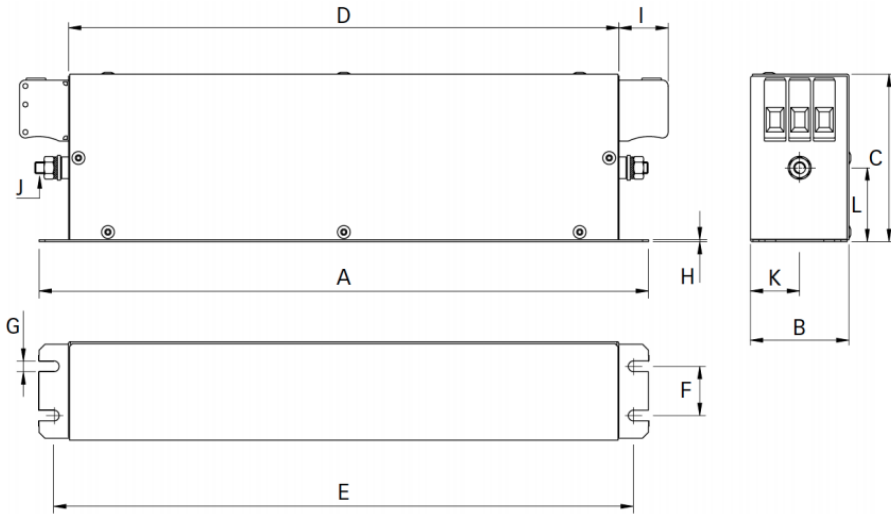

Fig 2.4.6 FN2090 series

	FN3258-7-44	FN3258-16-44	FN3258-30-33	FN3258-42-33
A	190	250	270	310
B	40	45	50	50
C	70	70	85	85
D	160	220	240	280
E	180	235	255	295
F	20	25	30	30
G	4.5	5.4	5.4	5.4
H	1	1	1	1
I	22	22	25	25
J	M5	M5	M5	M6
K	20	22.5	25	25
L2	29.5	29.5	39.5	37.5

III Installation

3.1 Servo drives installation

3.1.1 Installation conditions

Environment conditions	Equipment location	In an indoor location, Prevent exposure from direct sunlight, Free from dust, tangy caustic gases, flammable gases, steam or the salt-contented, etc.
	Altitude	1000m or below
	Atmospheric pressure	86kPa~106kPa
	Operating temperature	-10℃~40℃
	Storage temperature	-20℃~60℃
	Humidity	Below 90% (no water-bead coagulation)
	Vibration Strength	Below 0.5G (4.9m/s ²) ,10~60Hz (Discontinuous)
	IP rating	IP20
Power system	TN system (Note)	

Note: TN system: A power distribution system having one point directly earthed, the exposed conductive parts of the installation being connected to that points by protective earth conductor.

3.1.2 Installation procedure and minimum clearances

In order to ensure the drive is well ventilated, ensure that the all ventilation holes are not obstructed and sufficient free space is given to the servo drive.

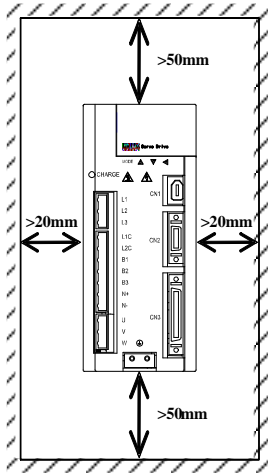

Fig 3.1.1 Minimum clearances for single drive

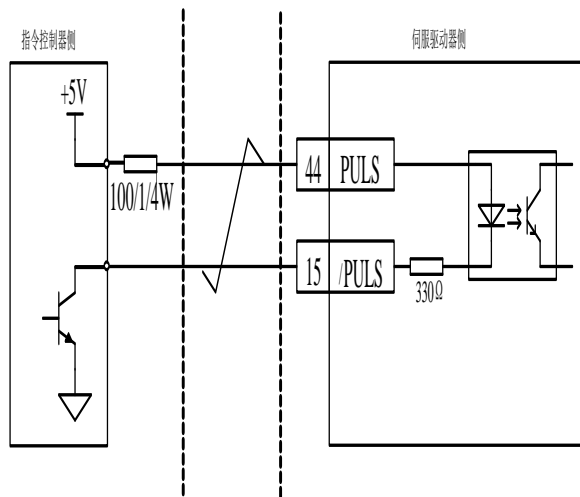

Fig 3.1.2 Minimum clearances for more drives

3.1.3 Servo drive dimension

M1 structure: (unit is mm)

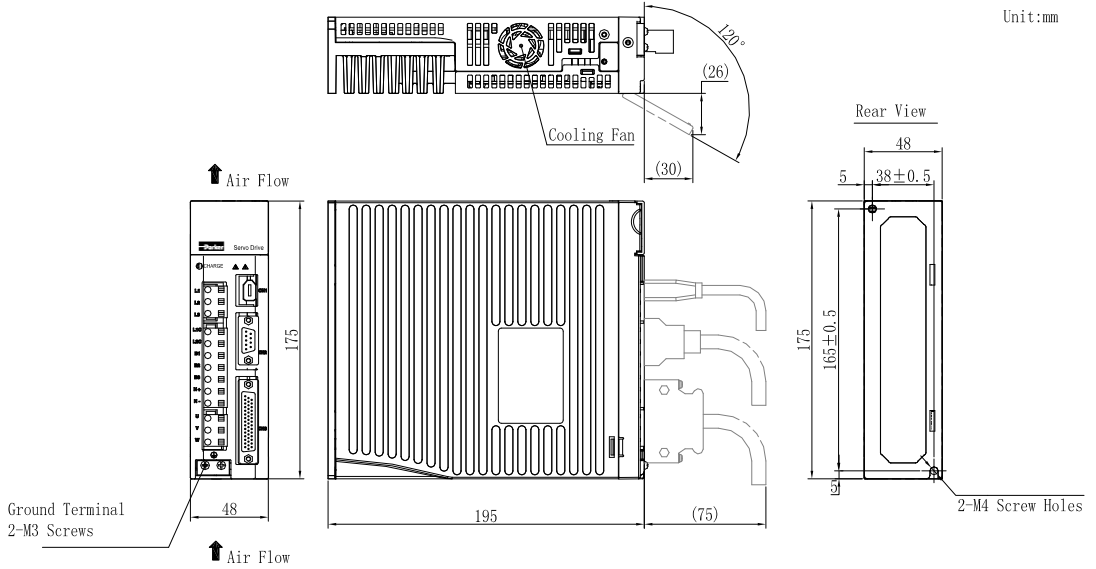

Fig 3.1.3 Servo drive structure 1

M2 structure: (unit is mm)

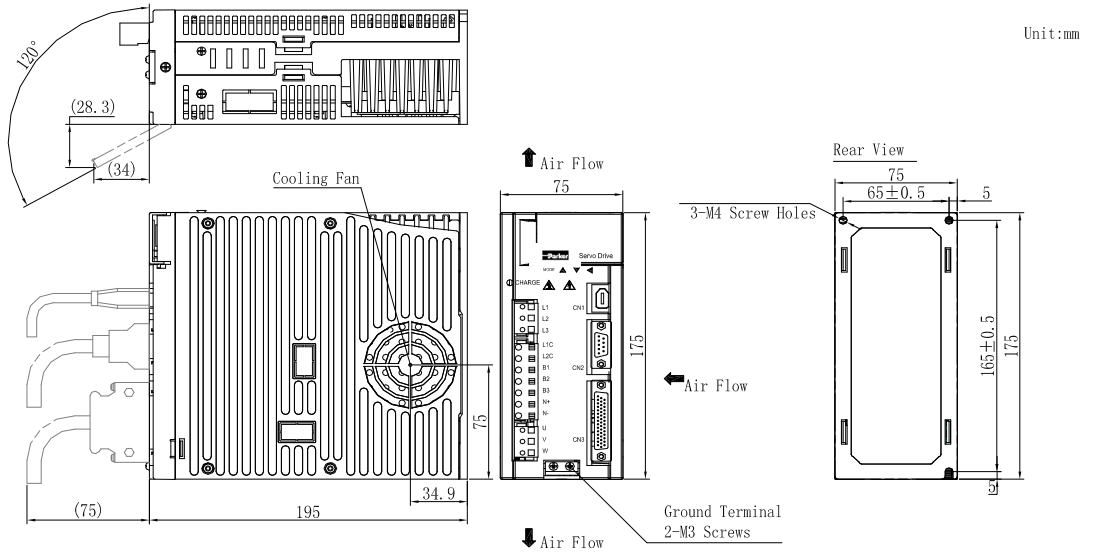

Fig 3.1.4 Servo drive structure 2

M3 structure:

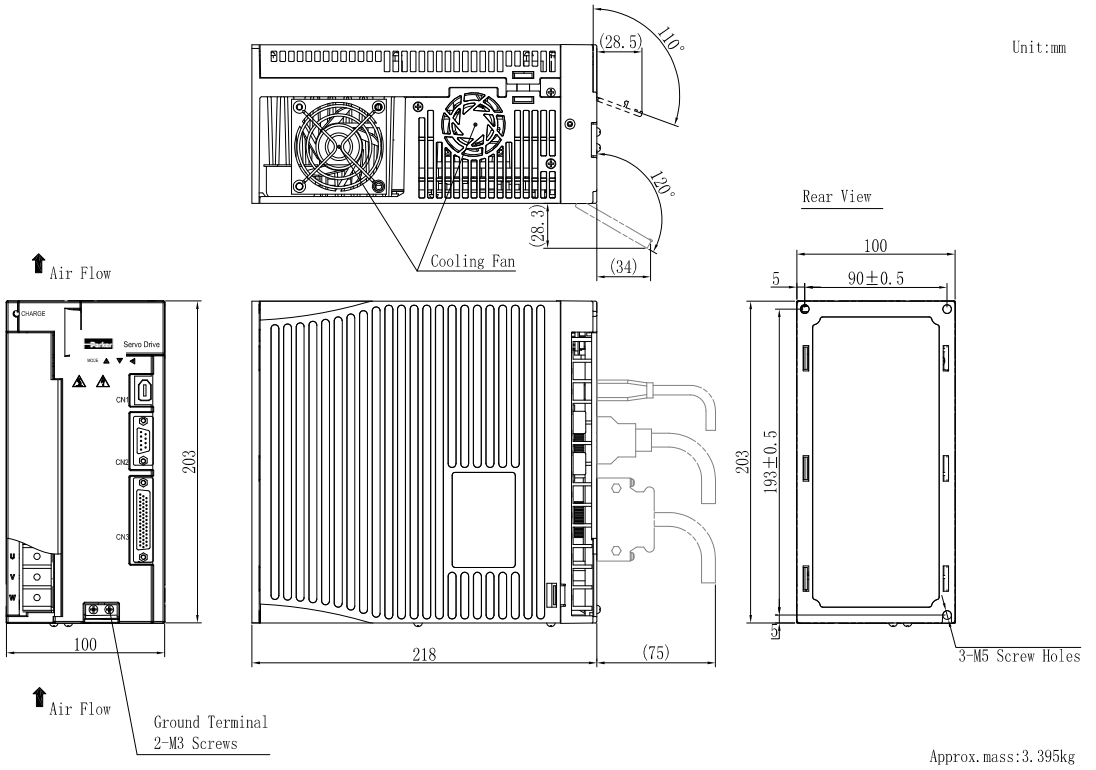

Fig 3.1.5 Servo drive structure 3

MM4 structure:

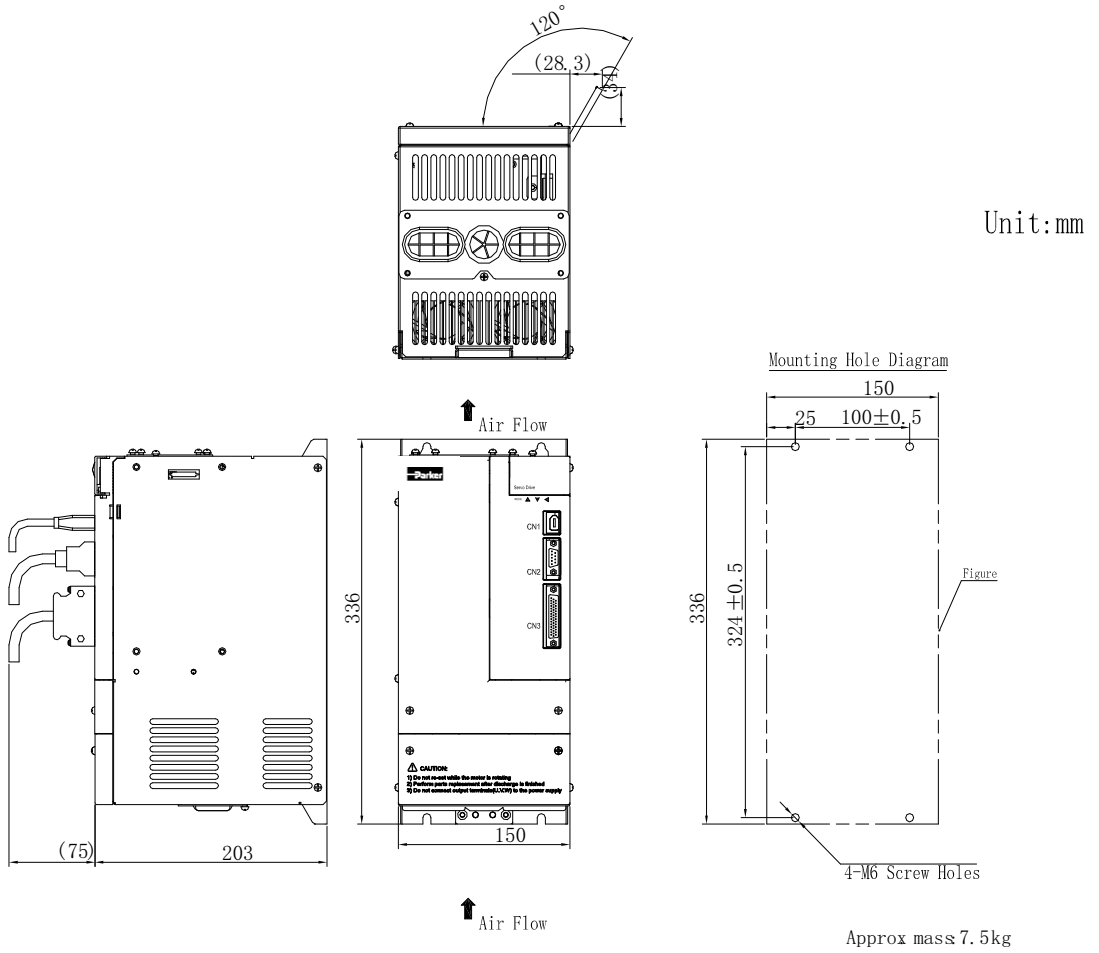

Fig 3.1.6 Servo drive structure 4

M4 structure:

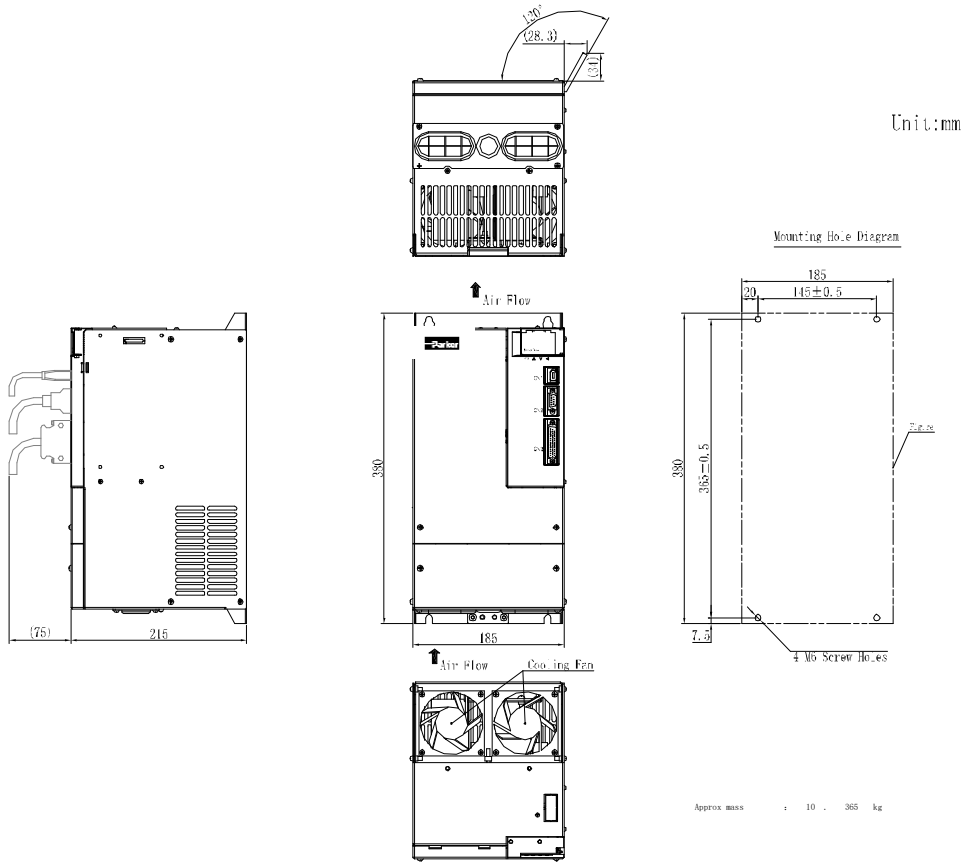

Fig 3.1.7 Servo drive structure 5

M5 structure:

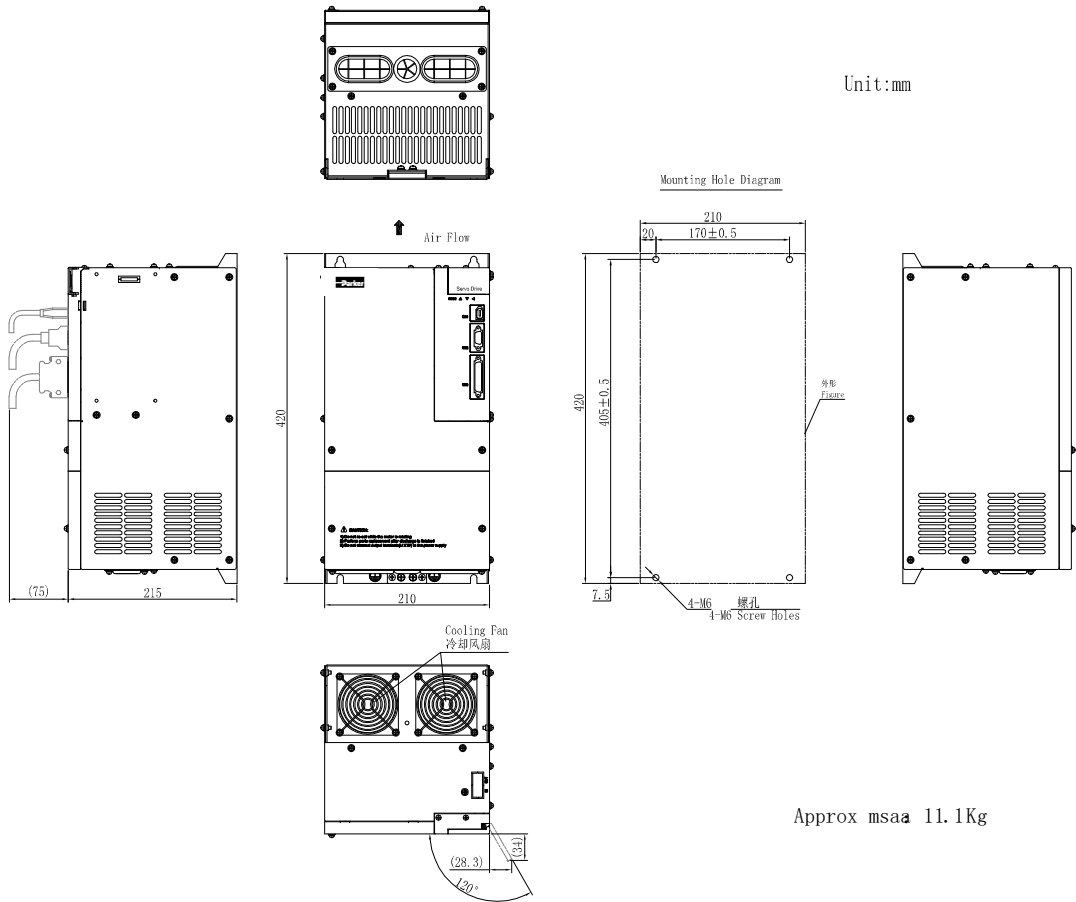

Fig 3.1.8 Servo drive structure 6

M6 structure:

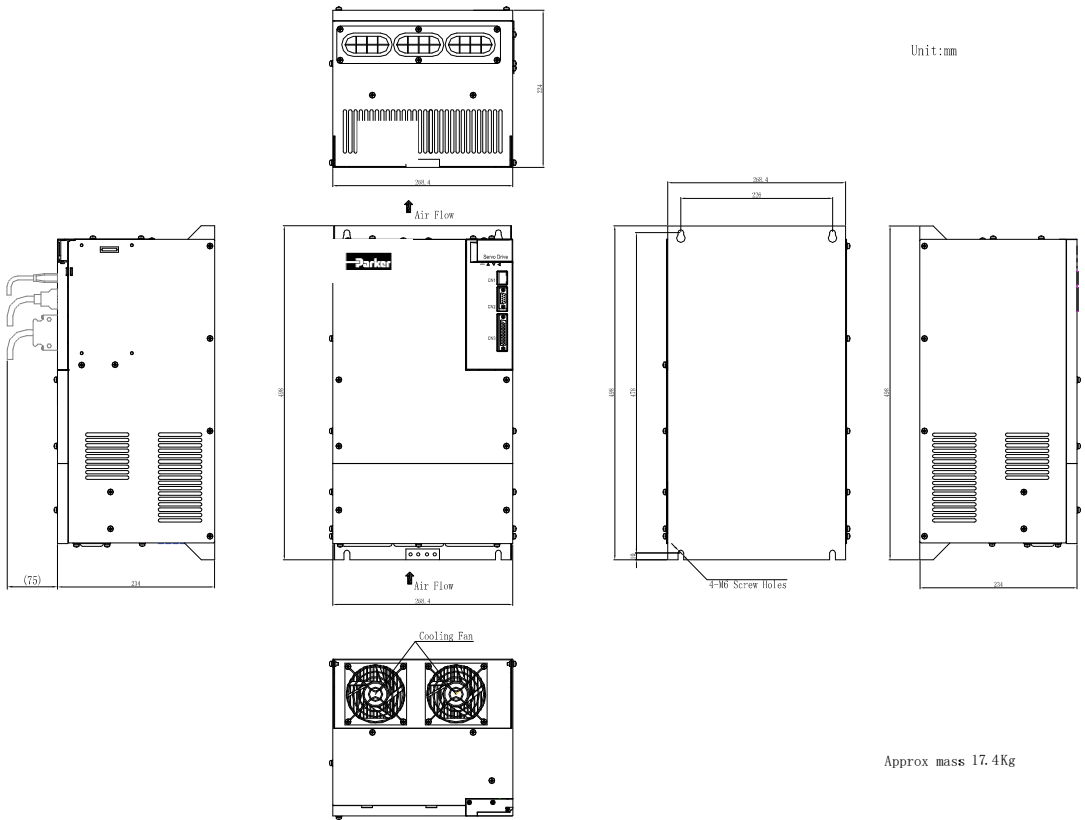

Fig 3.1.9 Servo drive structure 7

3.2 Servo motor installation

3.2.1 Installation location

1. Install the servo motor in an environment free from corrosive or inflammable gases or combustibles, such as hydrogen sulfide, chlorine, ammonia, sulphur gas, chloridize gas, acid, soda and salt.
2. Select and use the servo motor with oil seal in a place with grinding fluid, oil spray, iron powder or cuttings.
3. Install the servo motor away from heat sources such as heating stove.
4. Never use the servo motor in an enclosed environment. Working in the enclosed environment will lead to high temperature of the servo motor, which will shorten its service life.

3.2.2 Installation conditions

Environment conditions	Equipment location	Prevent tangy caustic gases and flammable gases
	Altitude	1000m or below
	Atmospheric pressure	86kPa~106kPa
	Operating temperature	-15°C~40°C (no freezing)
	Storage temperature	-20~80°C
	Humidity	Below 90% (no water-bead coagulation)
	Vibration Strength	Below 0.5G (4.9m/s ²), 10~60Hz (Discontinuous)
	IP rating	IP64

3.2.3 Precautions on servo motor installation

Item	Description
Anticorrosive	Before starting installation, thoroughly remove the anticorrosive paint that coats the end of motor shaft.
Alignment	Align the shaft of the servo motor with the shaft of the equipment, and then couple the shafts.
Orientation	Servo motor can be installed either horizontally or vertically.
Handling oil and water	<p>If the servo motor is used in a location that is subject to water drops, make sure of servo motor protective specifications.</p> <p>If the servo motor is used in a location that is subject to water or oil mist, use a servo motor with oil seal.</p> <p>Precautions on using servo motor with oil seal</p> <ul style="list-style-type: none"> ·The oil surface must be under the oil seal lip. ·Use an oil seal in favorably lubricated condition. ·When servo motor is installed vertically, be sure that oil will not stay in the oil seal lips.
Cable stress	<p>Make sure there are no bends or tension on the power cables.</p> <p>Be especially carefully to wire signal cables so that they are not subject to stress because the core wires are very thin at only 0.2 to 0.3mm.</p>
Connectors	<p>Observe the following precautions:</p> <ul style="list-style-type: none"> ·Make sure there is no foreign matters such as dust and metal chips in the connector before connecting. ·when the connectors are connected to the motor, be sure to connect the end of servo motor circuit cables before connecting the encoder cable's end. If the encoder cable's is connected, the encoder may be damaged because of the voltage differences between PE. ·Make sure of the pin arrangement. ·Do not apply shock to resin connectors. Otherwise, they may be damaged. ·When handling a servo motor with its cable connected, be sure not to apply stress on the connector. The connector may be damaged by stress.

3.2.4 Servo motor dimension

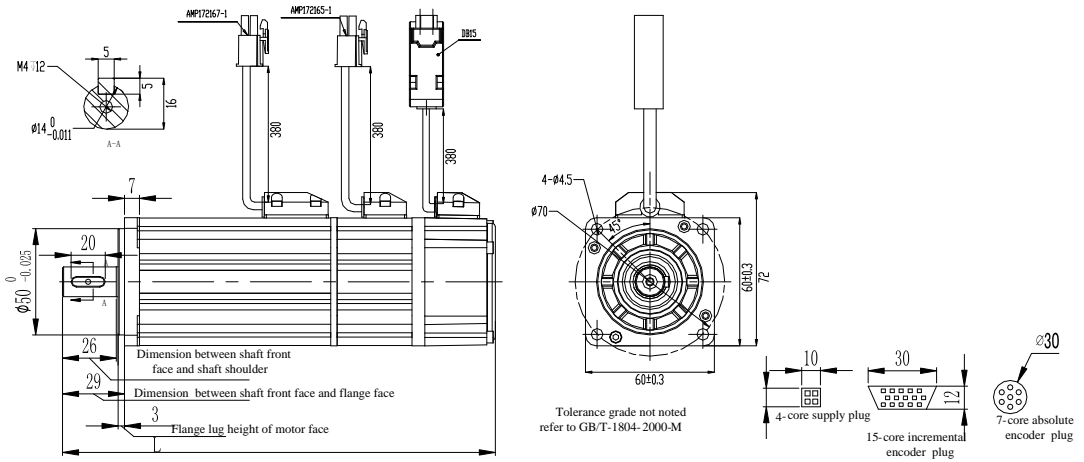

3.2.1 Dimension of servo motor

Model	L (mm)	L(mm) With brake	Weight(Kg)	Remarks
FMSA-201F/S32***	130.5	162.5	1.2	The screw hole size is: M4 X 12
FMSA-401F/S32***	163	195	1.6	

80 Flange Motor

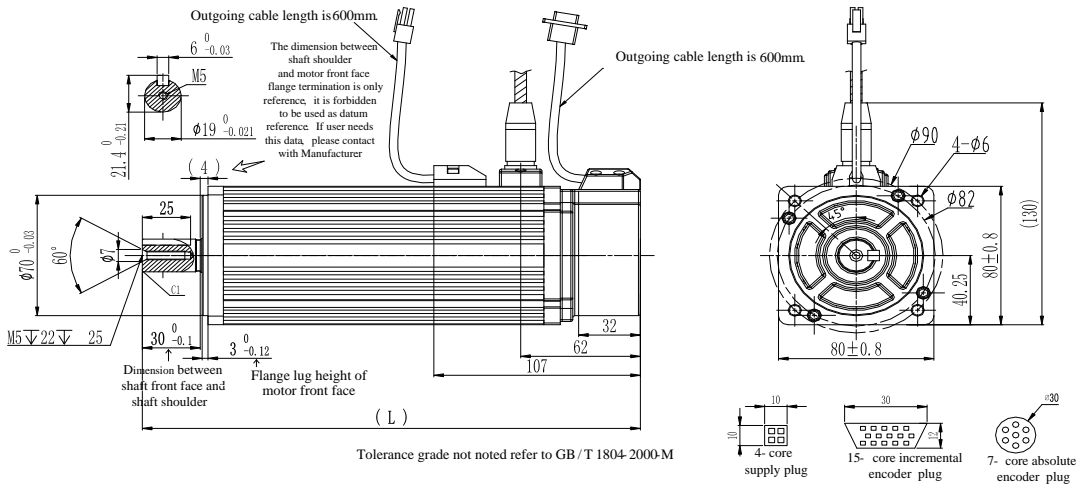

3. 2. 2 Dimension of servo motor

Model	L (mm)	L (mm) With brake	Weight (Kg)	Remarks
FMSA-751**3***	192	231	2.8	The screw hole size is M5X22
FMSA-102**3***	219	258	3.8	

110Flange Motor

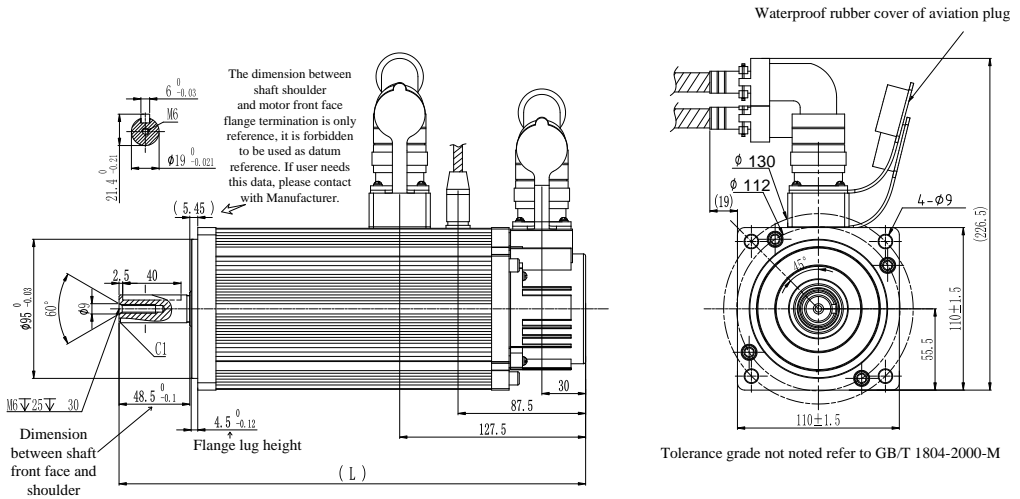

3. 2. 3 Dimension of servo motor

Model	L (mm)	L (mm) With brake	Weight (Kg)	Remarks
FMSA-122**5*** FMMA-801**5***	250	290	6.5	The screw hole size is M6 X 25
FMSA-182**5*** FMMA-122**5***	280	320	8	

130 Flange Motor

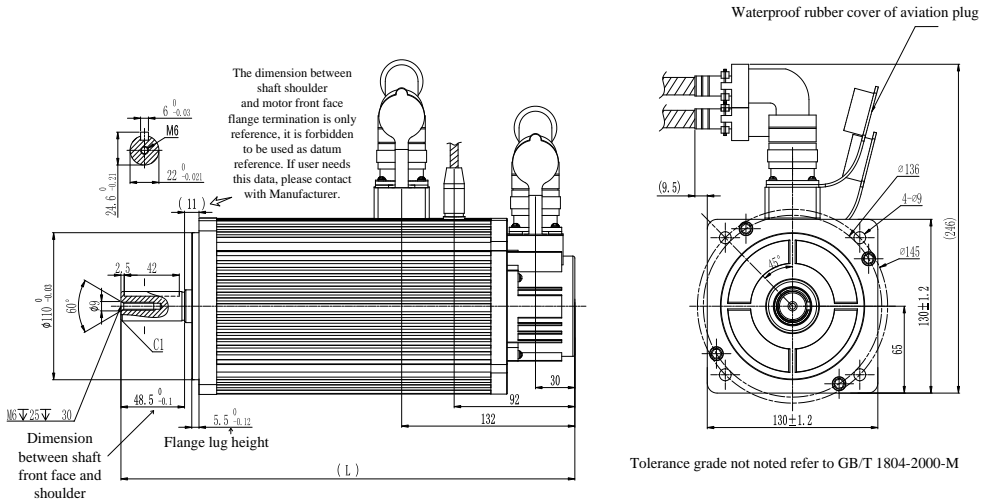

3.2.4 Dimension of servo motor

Model	L (mm)	L (mm) With brake	Weight (Kg)	Remarks
FMMA-851**7*** FMSA-152**7*** FMMA-102**7***	230	275	7	The screw hole size is M6 X 25
FMMA-132**7***	238	283	7.7	
FMSA-232**7*** FMMA-152**7*** FMMA-122**7***	251	296	8	
FMSA-302**7*** FMMA-202**7*** FMMA-152**7*** FMLA-102**7***	274	319	10	
FMMA-312**7*** FMLA-152**7*** FMMA-232**7***	301	346	12	

FM15, FM17, FM20 series, Air-cooling

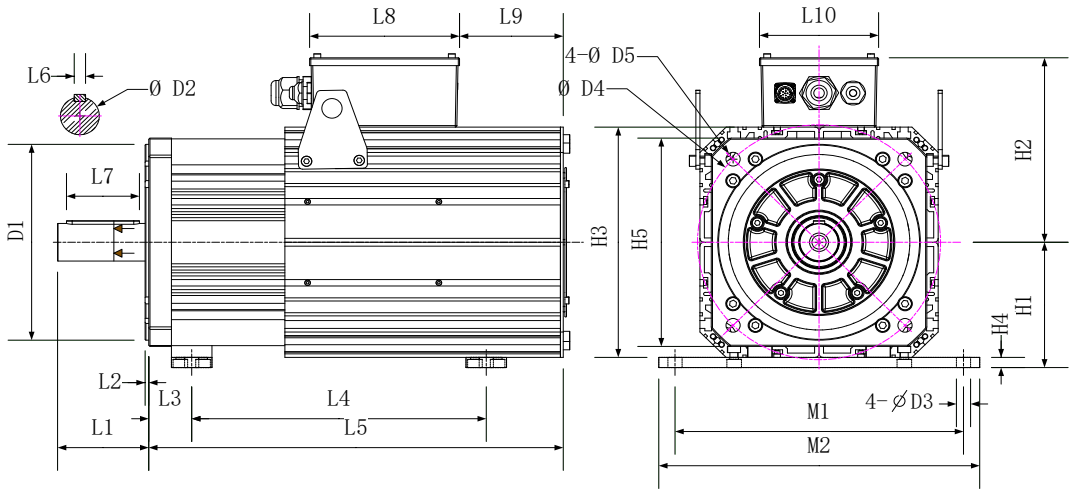

Fig 3.2.6 Dimension of servo motor

Stand spigot	D1	D2	D3	D4	D5	L1	L2	L3	L6	L7	L8	L9	L10	H1	H2	H3	H4	H5	M1	M2
E	180	42	14	215	14.5	77	5	39	12	56	185	75.5	147	124	200	224	12	200	254	278
F	250	48	18	300	17.5	112.5	4.5	53	14	90	185	128	147	160	240	294	13	266	356	396

Motor rated torque Nm ($\Delta T=100^{\circ}C$)	46	68	84	96	130	147	160	196	220	275	330	380	428	481
Motor rated torque Nm ($\Delta T=65^{\circ}C$)	42	52	64	80	102	118	135	152	185	225	270	307	324	385
Stand spigot	E	E	E	E	E	E	E	E	F	F	F	F	F	F
L4 (mm)	267	285	312	354	396	436	478	520	317	370	423	476	529	583
L5 (mm)	345	397	429	471	513	555	597	619	511.5	560.5	609.5	658.5	707.5	756.5

Note: 1-phase 220V power supply of 50 /60 Hz is usable for servomotor fan.

Green terminal definition: K-220VAC, L-220VAC, M-PE.

IV Wiring

This chapter provides servo system block diagram.

220V

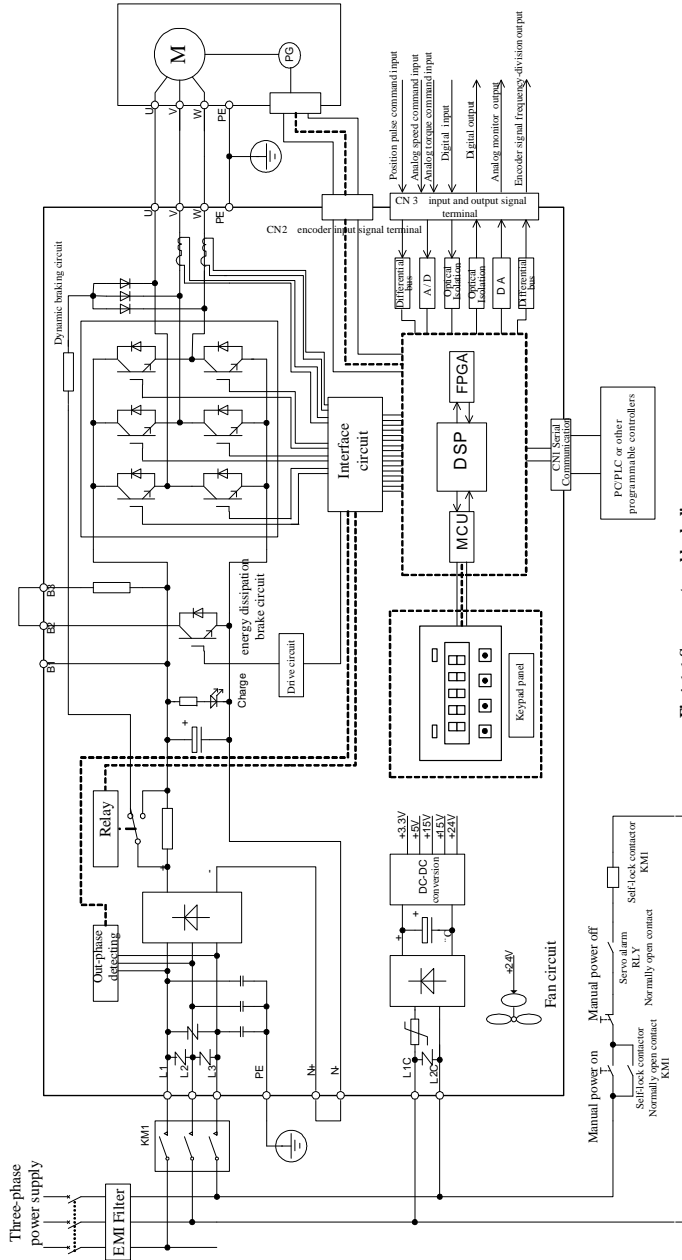

Fig4-1-1 Servo system block diagram

Fig 4.1.1 220V servo drive schematic diagram

380V

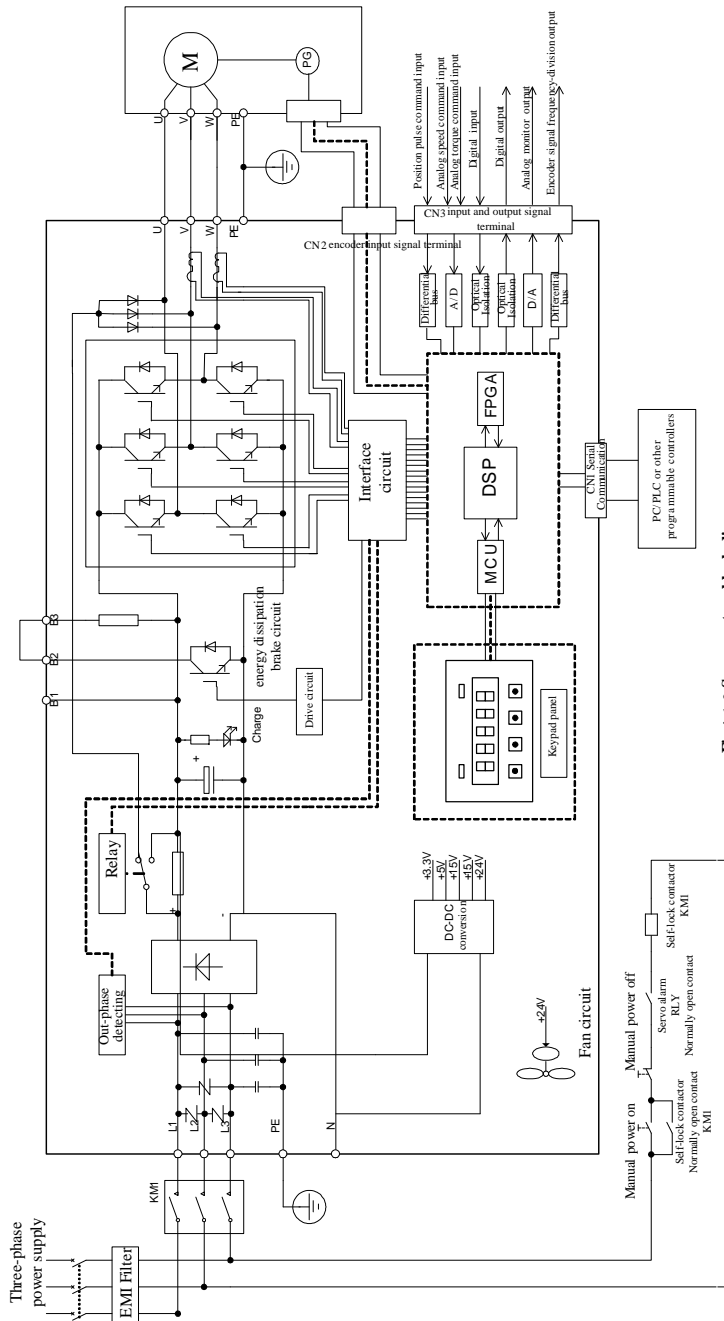



Fig4-1-2 Servo system block diagram

Fig 4.1.2 380V servo drive schematic diagram



4.1 Main circuit wiring

4.1.1 Main circuit terminals

(1) Main circuit terminals of 220V servo drive

Terminal identification	Terminal description	Functions
L1/R, L2/S, L3/T	Main circuit terminal	Used to connect three-phase AC 220V power. L1 and L3 are used to connect to single-phase 220V power.
L1C, L2C	Control circuit terminal	Used to connect to two phases of three-phase power or single-phase power.
B1/P, B2/B, B3	B2, B3: internal braking resistor terminal	Normally short-connect B2 and B3. Built-in braking resistor is installed. (M1 structure servo drive doesn't have built-in braking resistor.)
	B1/P, B2/B: external braking resistor terminal	Normally not connected. Remove the wire between B2 and B3 and connect an external braking resistor between B1 and B2 if the internal resistor is insufficient.
N+, N-	DC choke terminal	Normally short-connect N+ and N-. If a countermeasure against power supply harmonic is needed connect a DC choke between N+ and N- terminals.
U, V, W	Servo motor output	Used to connect to servo motor.
 , 	Ground terminal	Used to connect to the grounding.

(2) Main circuit terminals of 380V servo drive

Terminal identification	Terminal description	Functions
R/L1, S/L2, T/L3	Main circuit terminal	Used to connect three-phase AC 380V power.
L1C, L2C	Forbidden being connected	Invalid
B1/P, B2/B, B3	B2, B3: internal braking resistor terminal	Normally short B2 and B3. Internal braking resistor is used. (MM4 and above MM4 structure servo drive doesn't have built-in braking resistor.)
	B1/P, B2/B: external braking resistor terminal	Normally not connected. Remove the wire between B2 and B3 and connect an external braking resistor between B1 and B2 if the internal resistor is insufficient.
N+, N-, -	DC bus	Forbidden being connected to Grounding
U, V, W	Servo motor output	Used to connect to servo motor.
 , 	Ground terminal	Used to connect to the grounding.

4.1.2 Main circuit terminal wiring

(1) Wiring size

The following are applicable wire sizes:

Single wire: $\varnothing 0.5\sim\varnothing 1.6\text{mm}$; Braided wire: $0.8\text{ mm}^2\sim 3.5\text{mm}^2$ (American standard AWG28~AWG12)

(2) Connection procedure

- 1 Strip the end of the wire about 5~6mm.
- 2 Use a supplied lever or a standard flat-blade screwdriver (blade width of 3.0 to 3.5 mm). Put them into the slot, and press down firmly to open the wire terminal.
- 3 Insert the wire core into the opening and then close the opening by releasing the lever or removing the screwdriver.

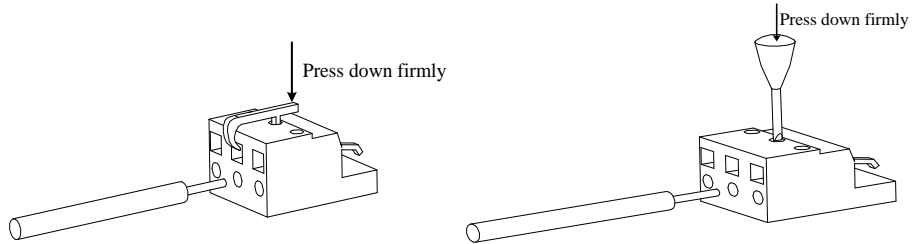

Fig 4.1.3 Connection procedure

4.1.3 Typical main circuit wiring examples

For 220V servo drive

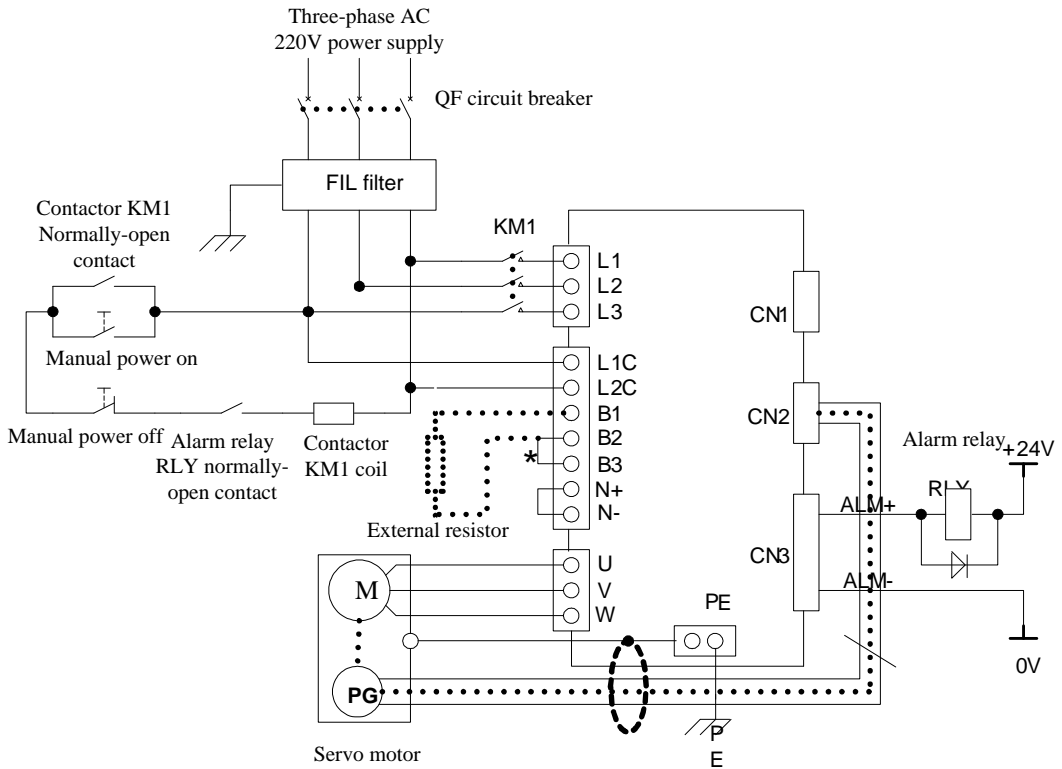

Fig 4-1-4 Typical main circuit wiring of 220V servo drive

Note:

1. Built-in resistor is default and B2 and B3 terminal is short-circuit. If external resistor is used, please remove the short cable between B2 and B3, and then connect external resistor between B1 and B2.
2. RLY: Alarm-signal output relay.
3. KM1: Contactor, connect or disconnect to main circuit power supply through manual switch.
4. If absolute encoder multi-turn function is adopted, please install battery.

⚠ Note: please connect an emergency stop circuit to main circuit so that servodrive can stop and power off immediately in case accident occurs.

For 380V servo drive

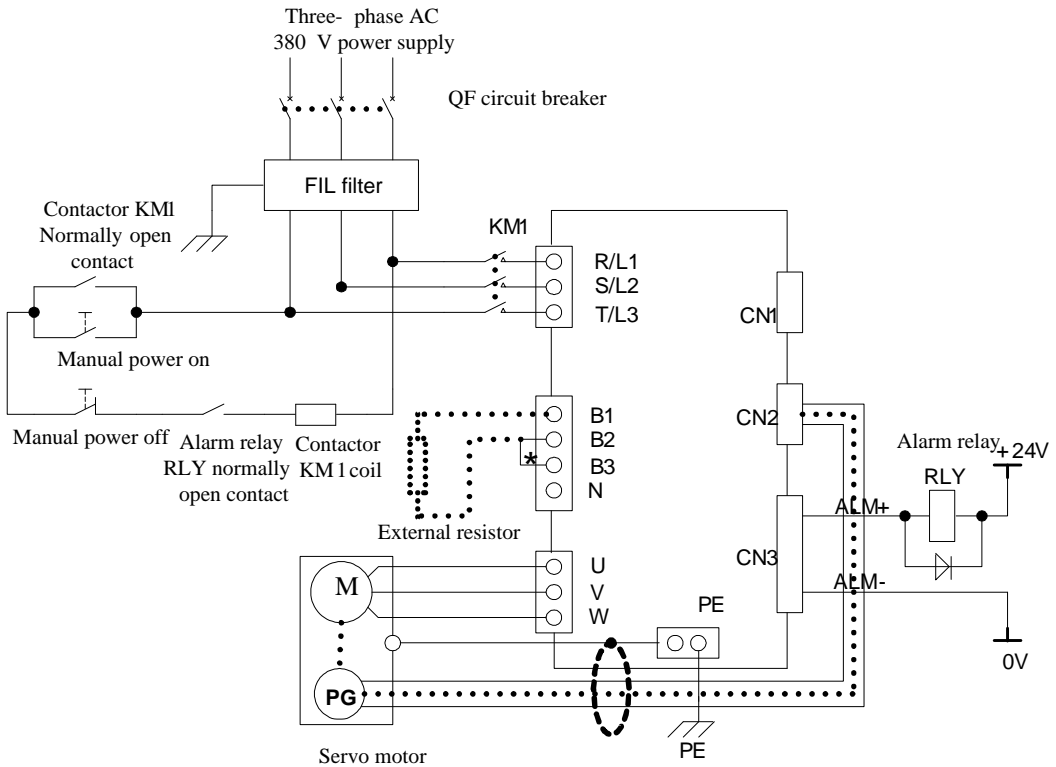

Fig 4-1-5 Typical main circuit wiring of 380V servo drive

Note:

1. Built-in resistor is default and B2 and B3 terminal is short-circuit. If external resistor is used, please remove the short cable between B2 and B3, and then connect external resistor between B1 and B2.
2. RLY: Alarm-signal output relay.
3. KMI: Contactor, connect or disconnect to main circuit power supply through manual switch.
4. N: DC bus.



Note: please connect an emergency stop circuit to main circuit so that servodrive can stop and power off immediately in case accident occurs.

4.1.4 Precaution for main circuit wiring

1. Don't connect input cable to U/V/W, or else, servo drive will be damaged.
2. When user connects external resistor, please remove the wire between B2 and B3 and connect external resistor between B1 and B2. Wrong wiring may damage servo drive.
3. Don't connect braking resistor between B1 and N+(N-), it will cause fire.
4. When cable is bundled and put in pipe, please consider reduction rate of allowable current for heat dissipation.
5. On high temperature condition, please select heat-resisting cable, common cable may be aged in a short time. In low temperature environment, please make thermal insulation for cable, common cable is easy to harden and crack.
6. Make sure that bending radius of cable is more than 10 times of outer diameter to prevent cable core break.
7. Don't put power cable and signal cable in one pipe or bundle them together. Distance of the two cables should be more than 30cm to avoid interference.
8. Servo drive remains high voltage after power off, don't touch power terminal for 5 minutes.
9. Please select earth wire with same area of main circuit.
10. Please ground servo drive reliably.
11. Don't power on when terminal screw or cable is loose, it will cause fire.
12. Only qualified personnel can connect the wiring.
13. To avoid electric shock or injury, when servo drive is powered off, please wait more than 5 minutes and indicator 'Charge' goes out, confirm there is no voltage between B1/P and N+/- by multimeter. Then user can disconnect or install servo drive.
14. Don't damage cable by hanging weight or extruding.
15. Make sure other wire and installation meet local regulations.

4.2 Encoder wiring

Precaution for encoder wire:

1. Make sure servo drive and motor are grounded reliably, otherwise servo drive may have wrong action.
2. Don't connect encoder cable to NC terminal.
3. User must consider of cable resistance and distributed capacitance to select cable length. Cable resistance may cause voltage drop, distributed capacitance will lead to signal attenuation,
4. Encoder cable and power cable must be fixed separately, with at least 30cm distance.
5. If encoder cable is not long enough and needs to connect additional cable, cable shielding layer must be also connected to ensure reliable shielding and grounding.

4.2.1 Absolute encoder connector terminal layout

CN2 Encoder Connector Terminal Layout is as shown in figure 4-2-1.

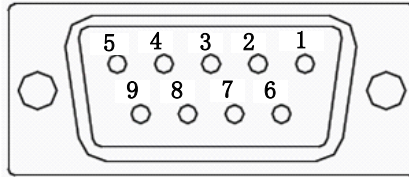

Fig 4.2.1 Absolute Encoder Connector Terminal Layout

Table 4.2.1 Encoder connector terminal

Terminal code	Terminal abbreviation	Signal name	Function
CN2- 1	NC	NO CONNECTION	NO CONNECTION
CN2- 2	VCC	+5V power	+5V power
CN2- 3	PS	PG serial signal	Serial signal
CN2- 4	/PS	PG serial signal	Serial signal
CN2- 5	GND	Grounding	Grounding
CN2- 6			
CN2- 7	NC	NO CONNECTION	NO CONNECTION
CN2- 8	NC	NO CONNECTION	NO CONNECTION
CN2- 9	NC	NO CONNECTION	NO CONNECTION
	HOUSING	—	(plug cover)

4.2.2 Resolver encoder connector terminal layout

CN2 Encoder Connector Terminal Layout is as shown in figure 4-2-2.

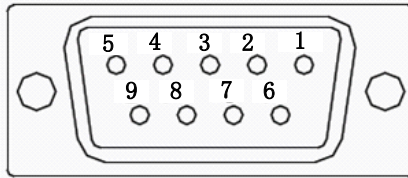

Fig 4.2.2 Resolver encoder connector terminal layout

Table 4.2.2 Encoder connector terminal

Terminal code	Terminal abbreviation	Signal name	Function
CN2- 1	RE2	Resolver signal stimulus	Connect to servo motor signal stimulus.
CN2- 2	VCC	Power of motor temperature sensor	Power of motor temperature sensor
CN2- 3	KTY	Signal of motor temperature sensor	Signal of motor temperature sensor
CN2- 4	NC	No connection	No connection
CN2- 5	RE1	Resolver signal stimulus	Connect to servo motor signal stimulus.
CN2- 6	COS-	Resolver differential signal	Connect to servo motor differential signal.
CN2- 7	COS+	Resolver differential signal	Connect to servo motor differential signal.
CN2- 8	SIN-	Resolver differential signal	Connect to servo motor differential signal.
CN2- 9	SIN+	Resolver differential signal	Connect to servo motor differential signal.
	HOUSING	—	(plug cover)

4.2.3 Incremental encoder connector terminal layout

CN2 Encoder Connector Terminal Layout is as shown in figure 4-2-3.

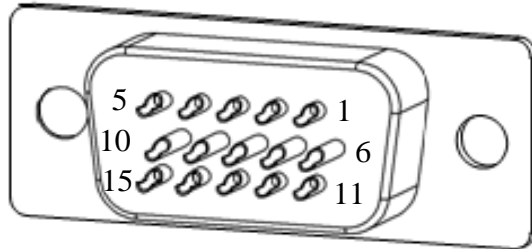

Fig 4.2.3 Incremental encoder connector terminal layout

Table 4.2.3 Encoder connector terminal

Terminal code	Terminal abbreviation	Signal name	Function
CN2- 1	V	Encoder V phase input	Connect to motor encoder V phase
CN2- 2	U	Encoder U phase input	Connect to motor encoder U phase
CN2- 3	Z	Encoder Z phase input	Connect to motor encoder Z phase
CN2- 4	B	Encoder B phase input	Connect to motor encoder B phase
CN2- 5	A	Encoder A phase input	Connect to motor encoder A phase
CN2- 6	/V	Encoder /V phase input	Connect to motor encoder /V phase
CN2- 7	/U	Encoder /U phase input	Connect to motor encoder /U phase
CN2- 8	/Z	Encoder /Z phase input	Connect to motor encoder /Z phase
CN2- 9	/B	Encoder /B phase input	Connect to motor encoder /B phase
CN2-10	/A	Encoder /A phase input	Connect to motor encoder /A phase
CN2-11	/W	Encoder /W phase input	Connect to motor encoder /W phase
CN2-12	W	Encoder W phase input	Connect to motor encoder W phase
CN2-13	VCC	+5V power	+5V power
CN2-14	GND	Grounding	Grounding
CN2-15	—	—	NO CONNECTION
	HOUSING	—	(plug cover)

4.3 I/O signal wiring

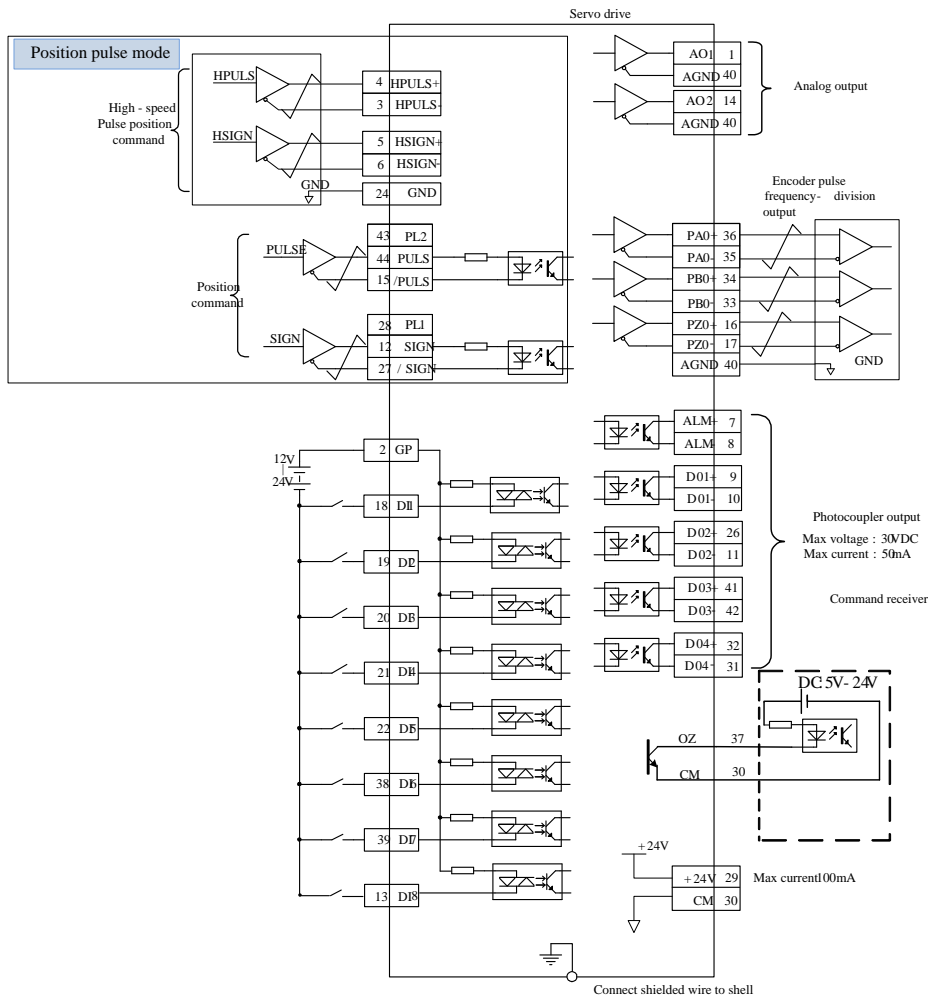
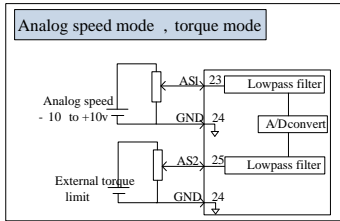

Fig 4.3.1 Wiring diagram in 3 kinds of modes

I/O signal connector terminal layout (connect to CN3) is as following fig when viewed from the solder pieces.

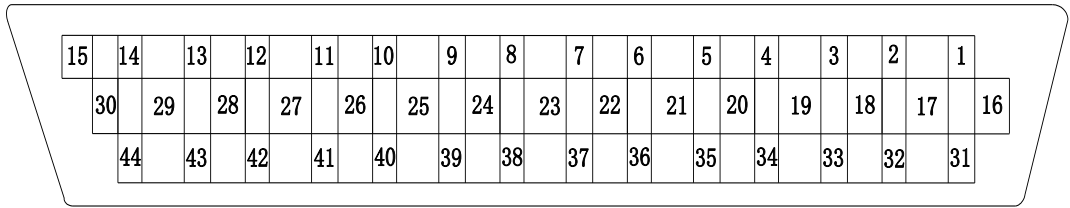

Fig 4.3.2 I/O signal connector terminal layout

1	AO1
2	GP
3	HPULS-
4	HPULS+
5	HSIGN+
6	HSIGN-
7	ALM+
8	ALM-
9	DO1+
10	DO1-
11	DO2-
12	SIGN
13	DI8
14	AO2
15	/PULS

16	PZO+
17	PZO-
18	DI1
19	DI2
20	DI3
21	DI4
22	DI5
23	AS1
24	GND
25	AS2
26	DO2+
27	/SIGN
28	PL1
29	+24V
30	CM

31	DO4-
32	DO4+
33	PBO-
34	PBO+
35	PAO-
36	PAO+
37	ZO
38	DI6
39	DI7
40	AGND
41	DO3+
42	DO3-
43	PL2
44	PULS

4.3.1 Position command input signal and function

Table 4.3.1 Position command signal

Signal name		Pin No.	Function	
Position command	PULS	CN3-44	Low-speed pulse command input modes: differential drive input and open-collector.	Input pulse types: Direction+pulse A+B phase orthogonalpulse CW/CCW pulse
	/PULS	CN3-15		
	SIGN	CN3-12		
	/SIGN	CN3-27		
	HPULS+	CN3-4	High-speed pulse position command	
	HPULS-	CN3-3		
	HSIGN+	CN3-5	High-speed direction command	
	HSIGN-	CN3-6		
	PL1	CN3-28	Pulse direction input (24V)	
	PL2	CN3-43	Pulse command input (24V)	
GND	CN3-24	Signal reference terminal		

An output circuit for the reference pulse or symbol signal at the host controller can either be differentialdrive output or OC output.

Pulse		Max frequency	Remarks
Low-speed	Differential	500K	5V or 24V command
	OC	200K	
High-speed	Differential	4M	5V command

1) Low-speed pulse command input

a) Differential drive

5V differential drive signal can be inputted by pulse input terminals of PULS, /PULS and SIGN, /SIGN.

Take the example of terminals PULS and /PULS.

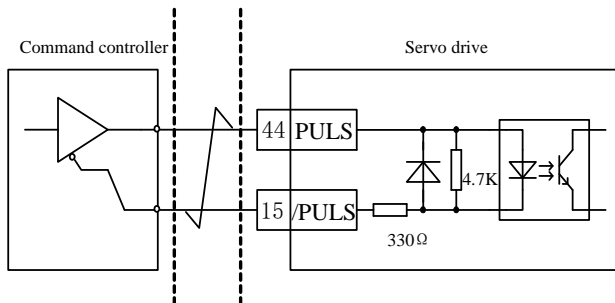

Fig 4.3.3 5V differential pulse input interface circuit

24V differential drive signal can be inputted by pulse input terminals of PL1, /SIGN and PL2, /PULS.
 Take the example of terminals PL2 and /PULS.

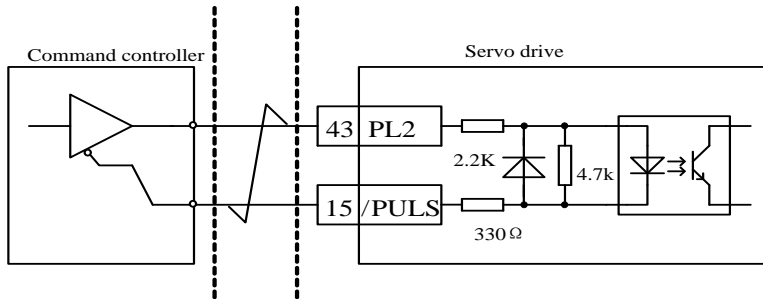

Fig 4.3.4 24V differential pulse input interface circuit

b) Single-end drive

The types of single-end drive include collector (drain) input, emitter (source) input and push pull input, and so on. The input types of differential signal have a better anti-jamming than single-end drive, and the transmission distance of single-end drive is shorter.

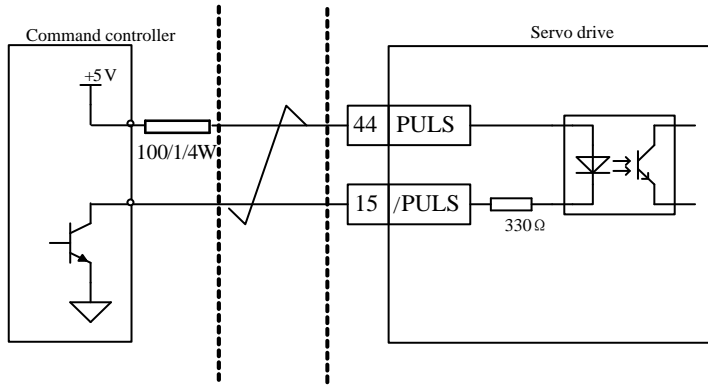

Fig 4.3.5 5V open-collector pulse input interface circuit

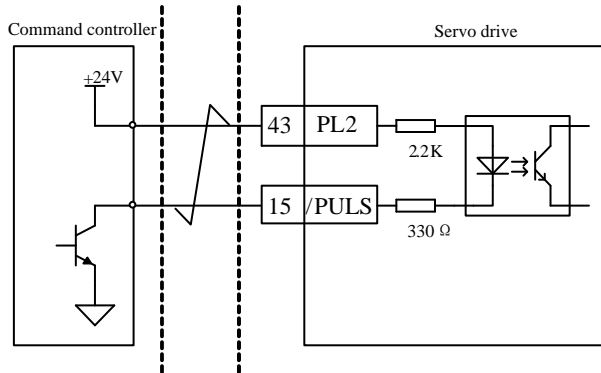
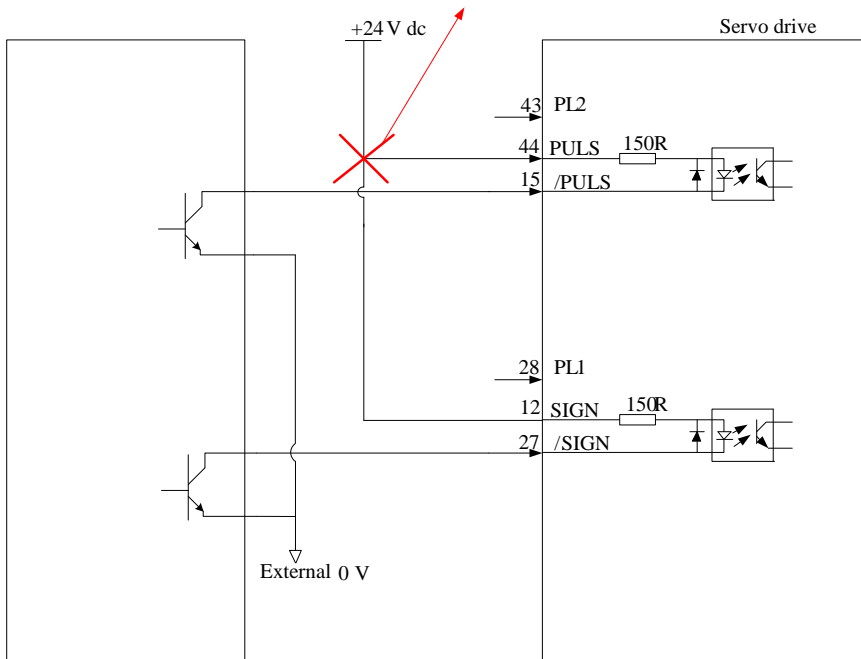

Fig 4.3.6 24V open-collector pulse input interface circuit

c) Wrong example:

Error 1: current-limiting resistor is not connected, which leads to port damaged.

- Two errors are as below:
1. If 24V internal servo drive is not used, please connect it to external resistor.
 2. if 24V internal servo drive is used, please connect to 43/28 pin.



Error 2: When SIGN signal is not connected, direction can not be converted.

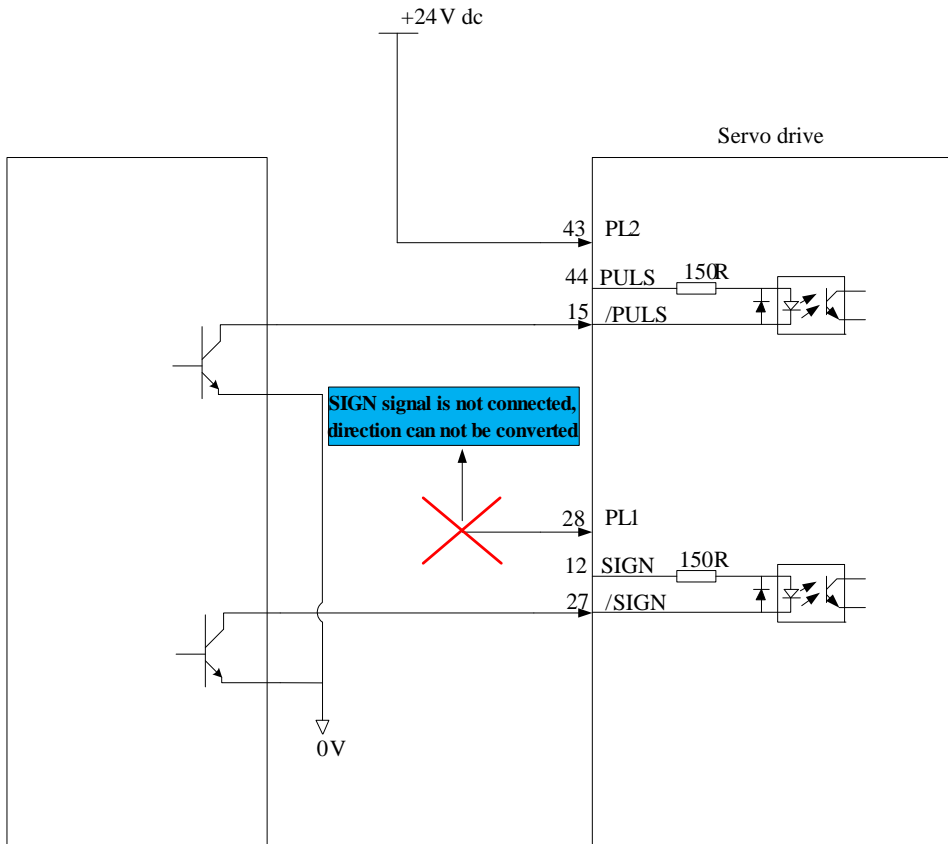

Error 3: there is no loop when 24V internal servo drive is used.

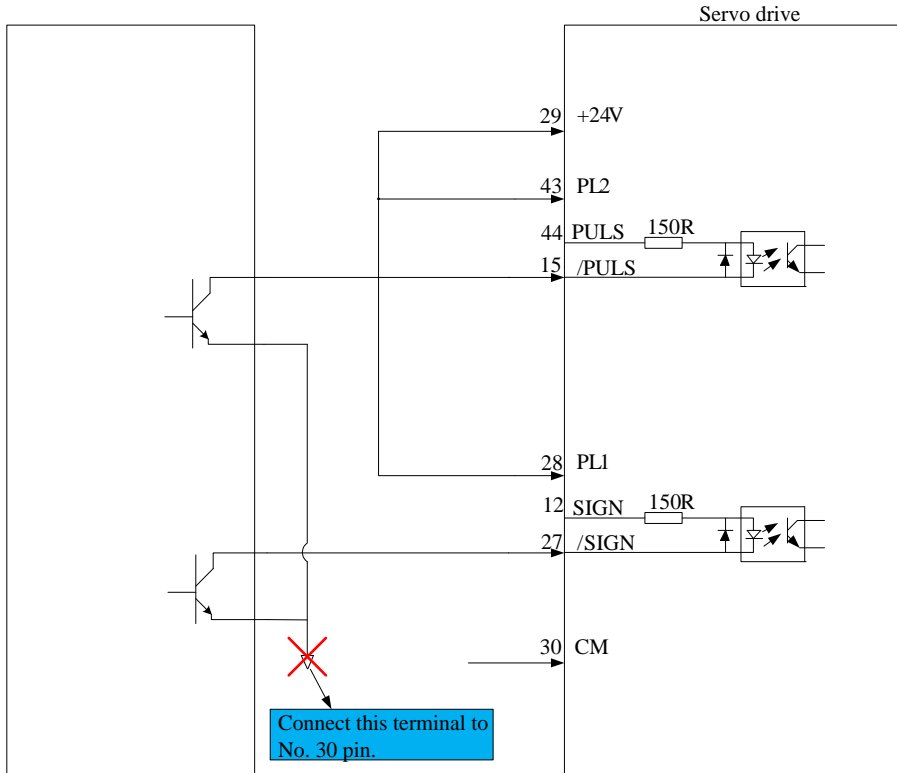

2) High-speed pulse command input

High-speed command pulse can be output to servo drive by differential drive.

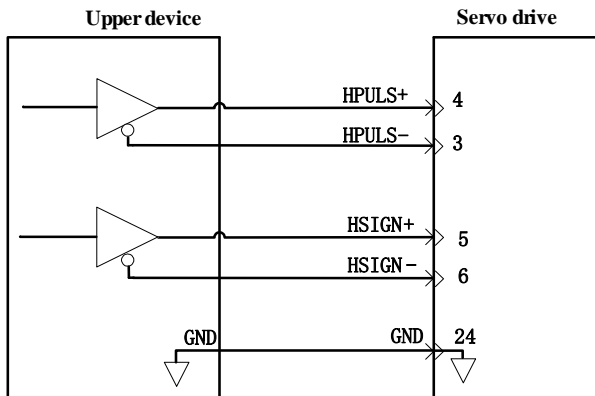

Fig 4.3.10 High-speed differential signal

- ★ Please make sure differential input voltage is 5V, otherwise servo drive receives pulse unsteadily or servo drive internal device will be damaged.
- ★ Please make sure the 5V power grounding is connected to GND, otherwise the following situation will

happen:

1. Some input pulse could be missed.;
2. There will be large interference when servo drive receives pulse.

4.3.2 Analog command input signal and functions

Signal name	Pin No.	Function
Analog	AS1+	CN3-23
	AS2+	CN3-25
	GND	CN3-24
		Resolution of analog input signal is 12 bits, input voltage range is -10V~+10V.
		Analog input signal reference terminal.

Speed and torque signal input terminals are AS1+ and AS2+, resolution is 12 bits. The voltage value is set byPo400/Po401.

- ★ Input voltage range: -10V~+10V, resolution is 12 bits.
- ★ Max voltage is $\pm 12V$.
- ★ Input resistor is about 50K Ω .

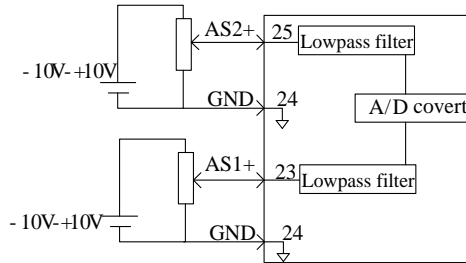

Fig 4.3.11 Analog input interface circuit

4.3.3 Analog output signal and functions

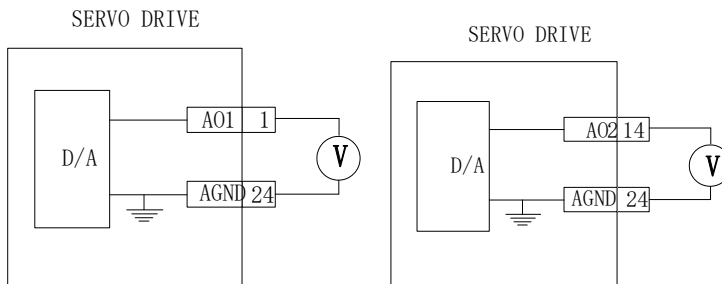

Fig 4.3.12 Analog monitor output interface

The voltage range of analog monitor is 0~10V, the range of output current is 0~10mA.

Signal	Monitor content
AO1, AO2	Motor speed, bus voltage, and servo drive output current.

4.3.4 Digital input signal and functions

Signal name		Pin No.	Function
Program mable input terminal	DI1	CN3-18	DI1-DI8 are digital input terminals, input mode is ON/OFF signal. Please refer to 8.1.7 DI/DO for the detailed function. DI input pulse frequency range is 0~3KHz
	DI2	CN3-19	
	DI3	CN3-20	
	DI4	CN3-21	
	DI5	CN3-22	
	DI6	CN3-38	
	DI7	CN3-39	
	DI8	CN3-13	
Signal name		Pin No.	Function
Program mable output terminal	DO1+	CN3-9	DO1-DO4 and ALM are DO output terminals, output mode is ON/OFF signal. Please refer to 8.1.7 DI/DO for the detailed function.
	DO1-	CN3-10	
	DO2+	CN3-26	
	DO2-	CN3-11	
	DO3+	CN3-41	
	DO3-	CN3-42	
	DO4+	CN3-32	
	DO4-	CN3-31	
	ALM+	CN3-7	
	ALM-	CN3-8	
Signal name		Pin No.	Function
Internal 24V	+24V	CN3-29	24V power supply, range is 20V-30V
	CM	CN3-30	Reference terminal

1) Digital input circuit

DI1~DI8 input terminals circuit is bidirectional photocoupler isolating circuit. The common terminal of photocoupler is GP terminal which is used to connect to power supply or grounding for power supply. Please refer to fig 4-4-1 and 4-4-2. Please select external DC power supply to supply the primary voltage of photocoupler in order to decrease the interference to internal circuit. DI8 is high-speed photoelectric channel, which is high-speed DI terminal. Input type of DI channel is as below:

(1) Passive contactor

Passive contacts include relay contactor, limit switch, general key, button and so on. The common contact circuit is as following figure:

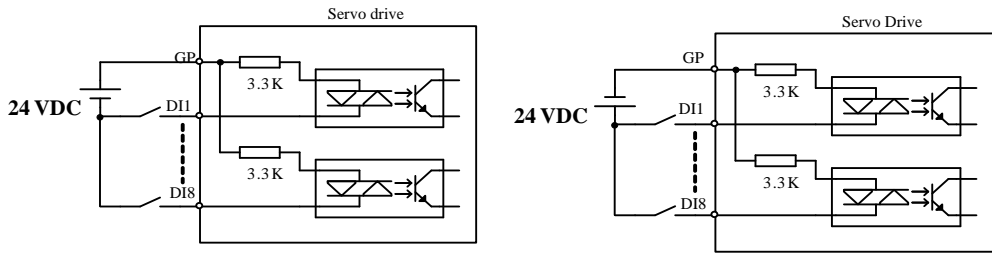
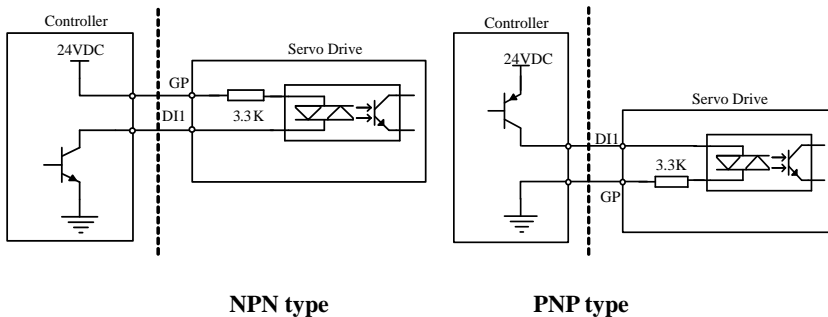

Fig 4-3-13 passive-contact interface circuit

(2) Active contactor

Active contactors include photoelectrical sensor, Hall sensor, transistor type PLC.



NPN type

PNP type

Fig 4-3-14 active contactor interface circuit

2) Digital output circuit

The output signal ALM and DO1~DO4 adopts photocoupler of Darlington output which has strong ability for drive and can drive small relay directly. It can drive heavier load by driving photocoupler. The max current should not be higher than 50mA.

(1) Relay output

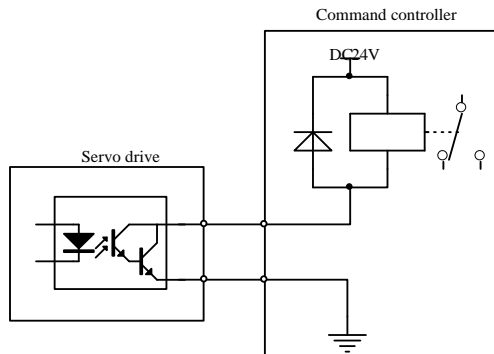

Fig 4-3-15 Relay output interface circuit

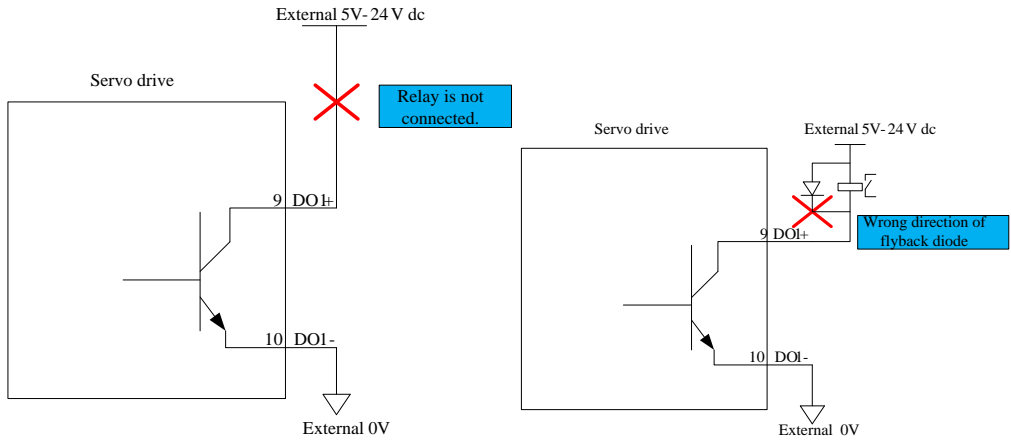

Fig 4-3-16 Wrong wiring of relay output interface circuit

⚠ Note: Relay is inductance load, please connect a freewheel diode in antiparallel between the load. If the freewheel diode is connected inversely, servo drives will be damaged.

(2) Photocoupler isolating output

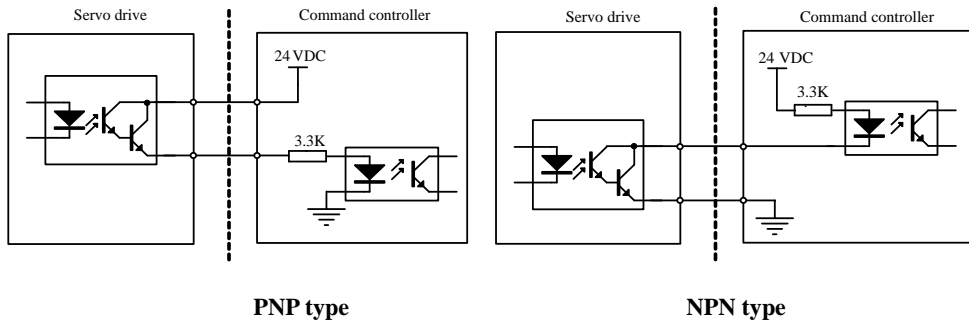

Fig 4-3-17 Photocoupler output interface circuit

⚠ Note:

1. Match usage of power supply and current-limiting resistor make external photocoupler on state.
2. Max allowable voltage and max current capacity of internal photocoupler output circuit is as below:
Voltage: DC 30V (Max)
Current: DC 50mA (Max)

4.3.5 Encoder frequency-division output signal and function

Signal name	Pin No.	Function	
Common output terminal	PAO+	CN3-36	Encoder A phase pulse frequency-division output
	PAO-	CN3-35	
	PBO+	CN3-34	Encoder B phase pulse frequency-division output
	PBO-	CN3-33	
	PZO+	CN3-16	Encoder Z phase pulse frequency-division output
	PZO-	CN3-17	
	OZ	CN3-37	Encoder Z-phase pulse outputs open collector signal
	CM	CN3-30	Reference terminal

Frequency-division circuit in the servodrive processes encoder input signal by the mode of frequency-division, which is output by differential bus mode. Interface circuit includes high-speed photocoupler interface and differential chip interface. Take the example of encoder A phase pulse frequency-division output.

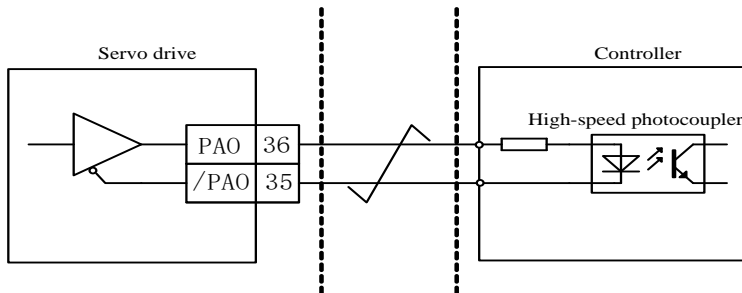

Fig 4-3-18 Photocoupler interface circuit

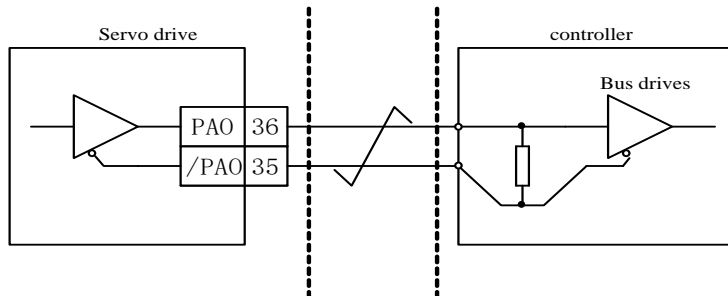

Fig 4-3-19 Differential chip interface circuit

Note: AM26LS32 is recommended as receiving chip, and 200Ω/1/4W match resistor is recommended.

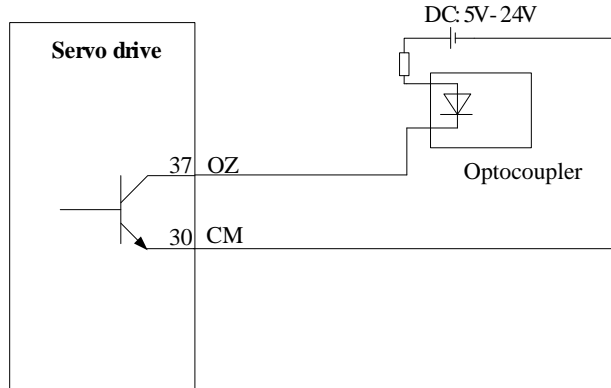

Fig 4-3-20 OZ signal interface circuit

4.3.6 Communication wiring

(1) Interface instruction

The RS485 communication interface is in the connector CN1.

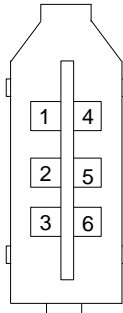

Fig 4-3-2 CN1 connector terminals

Terminal	Name	Function
CN1-1	VCC	5V power
CN1-2	RS232-RXD	Receiver terminal of RS232
CN1-3	B-	Differential output -
CN1-4	GND	Reference terminal
CN1-5	RS232-TXD	Transmission terminal of RS232
CN1-6	A+	Differential output +

4.3.7 Wiring when using more than one servos

Connect the alarm output (ALM) terminals for the three Servodrives in series to enable alarm detection relay RLY to operate. When the alarm occurs, the ALM output signal transistor is turned OFF.

1) Wiring diagram of more than one 220V servos

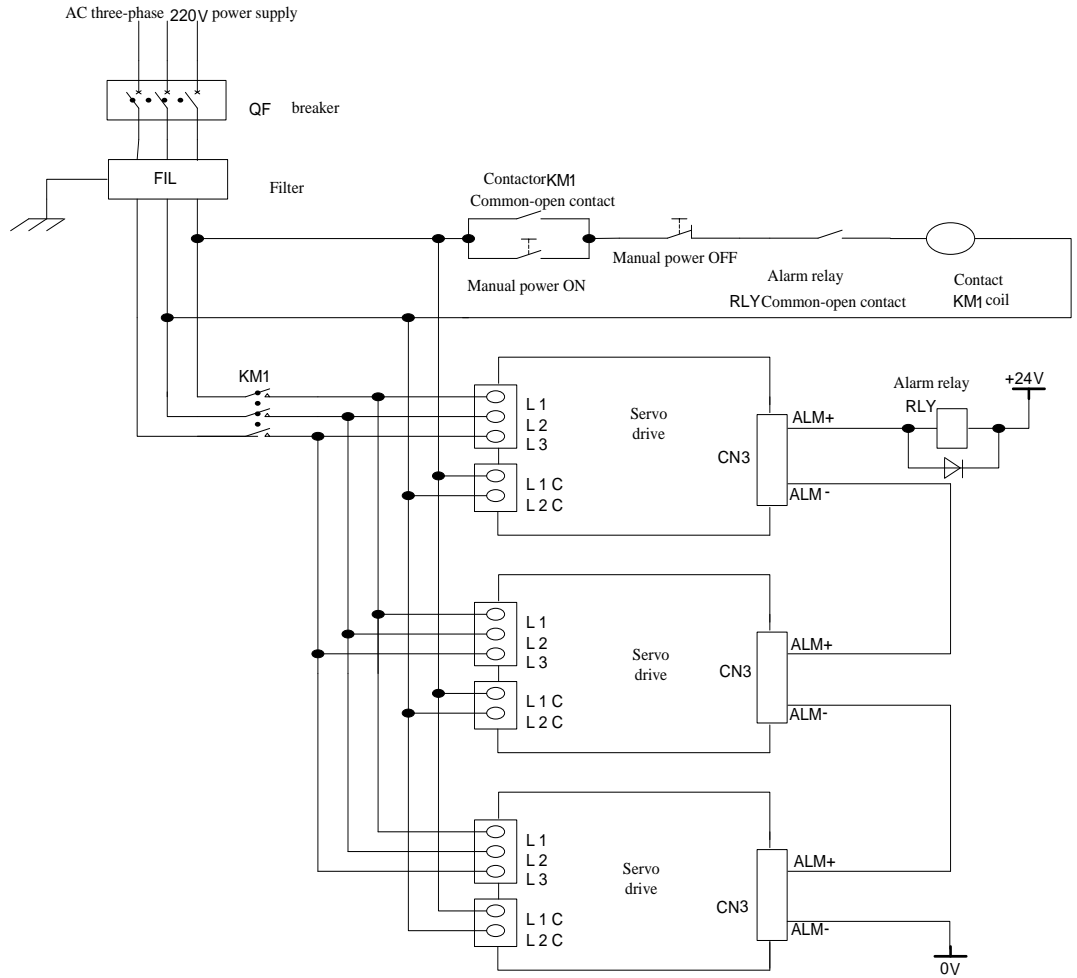

Fig 4.3.22 Wiring diagram of more than one 220V servos

2) Wiring diagram of more than one 380V servos

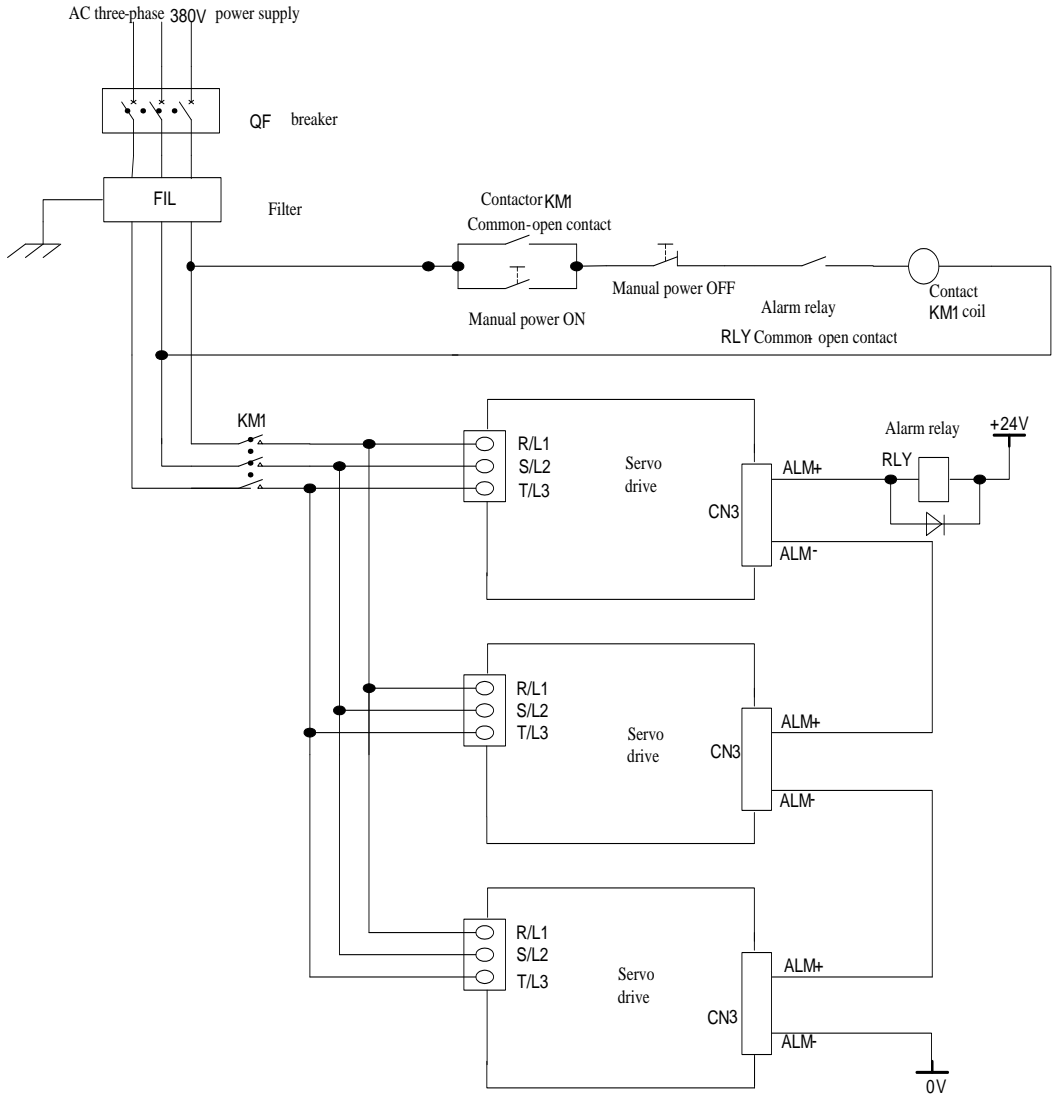

Fig 4.3.23 Wiring diagram of more than one 380V servos

4.3.8 Absolute value encoder

Encoder type	Resolution ratio	Multi-turn data output range	Action when out of allowed range
17 bit absolute encoder	16-bit multi-turn 17-bit single-turn	0~+65535	<ul style="list-style-type: none"> · Multi-turn data will turn to 0 when data exceeds upper limit (+65535) of forward direction. · Multi-turn data will turn to 0 when data exceeds lower limit (+65535) of reverse direction.

User can read absolute position when motor is standstill by MODBUS (please refer to 10.1.3), then motor real-time position can be got by PG frequency-division output pulse count.

1. Battery usage

Please install battery cell in order to save position data of absolute value encoder.

Please purchase Parker special cable and battery box of manufacture.

Battery installations steps:

A: open cover of battery cover.

B: Install battery as below figure:

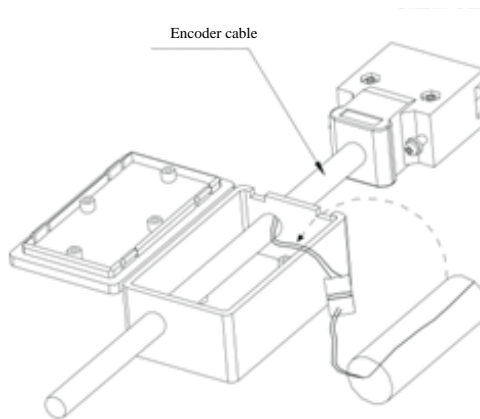

C: Close the cover of battery cell.

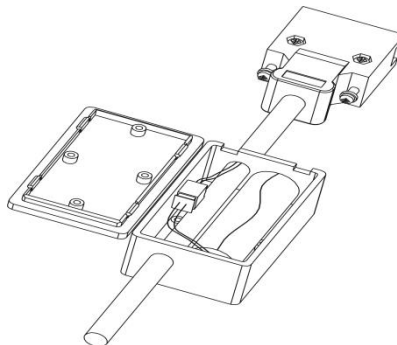

2. Battery replacement

When battery voltage drops to about 1.3V, servo drive will trip into “AL-19 (battery voltage is lower)”. Although multiturn data exists, user should change battery Immediate, otherwise multiturn data will be lost when battery voltage keeps dropping. Please change battery according to below steps:

- a. Please change battery when servo drive is POWER ON.
- b. After changing battery, reset servo drive by hold pressing “SET” key to clear “AL-19”.
- c. Repower on servo drive, if there is no abnormal situation, it means battery change succeeds.

Note: (1) When servo drive trips into AL-24(under voltage protection), servo drive can only be reset by setting HOME.

(2) If user wants to shield AL-24 alarm, please set So-38 to 0, reset encoder alarm by So-43, and reset servo drive by hold pressing “reset” key.

4.4 Servo drive and servo motor wiring

4.4.1 Encoder wiring

1) Absolute encoder layout

Table 4.4.1 Absolute encoder pulg layout

No.	Name	Function
1	PE	Grounding
2	VCC	Encoder power
3	GND	Encoder power grounding
4	BAT(+)	Battery cathode
5	BAT(-)	Battery anode
6	PS	Absolute encoder serial signal
7	/PS	Absolute encoder serial signal

2) Incremental encoder layout

Table 4.4.2 Incremental encoder DB15 plug layout

No.	Name	Function
1	A	Encoder A phase
2	B	Encoder B phase
3	Z	Encoder Z phase
4	U	Encoder U phase
5	V	Encoder V phase
6	/A	Encoder /A phase
7	/B	Encoder /B phase
8	/Z	Encoder /Z phase
9	/U	Encoder /U phase

10	/V	Encoder /V phase
11	W	Encoder W phase
12	/W	Encoder /W phase
13	VCC	Encoder power
14	GND	Encoder grounding
15	—	No connection
	HOUSING	HOUSING

Table 4.4.3 Incremental encoder aviation plug layout

No.	Name	Function	Remarks
1	PE	Grounding	
2	A	Encoder A phase	
3	/A	Encoder /A phase	
4	B	Encoder B phase	
5	/B	Encoder /B phase	
6	U	Encoder U phase	
7	/U	Encoder /U phase	
8	V	Encoder V phase	
9	/V	Encoder /V phase	
10	W	Encoder W phase	
11	/W	Encoder /W phase	
12	VCC	Encoder power	
13	GND	Encoder grounding	
14	Z	Encoder Z phase	
15	/Z	Encoder /Z phase	
16	KTY+	Motor thermistor signal	180 flange and above servo motor has 16/17 pin, other servomotor doesn't have the pin. Note: servodrive doesn't support the function.
17	KTY-	Motor thermistor signal	

3) Resolver encoder layout

Table 4.4.4 15-core encoder aviation plug

No.	Name	Function
1	PE	Grounding
2	COS+	Resolver differential signal
3	NC	No connection

4	NC	No connection
5	COS-	Resolver differential signal
6	NC	No connection
7	NC	No connection
8	NC	No connection
9	NC	No connection
10	SIN+	Resolver differential signal
11	NC	No connection
12	NC	No connection
13	SIN-	Resolver differential signal
14	RE1	Resolver excitation signal
15	RE2	Resolver excitation signal

Table 4.4.5 10-core encoder aviation plug

No.	Name	Function
1	RE1	Resolver excitation signal
2	RE2	Resolver excitation signal
3	COS+	Resolver differential signal
4	COS-	Resolver differential signal
5	SIN+	Resolver differential signal
6	SIN-	Resolver differential signal
7	KTY+	Motor thermistor signal
8	KTY-	Motor thermistor signal
9	PE	Grounding
10	NC	No connection

4.4.2 Power cable of servo drive and servo motor

a) 4-core power AMP plug

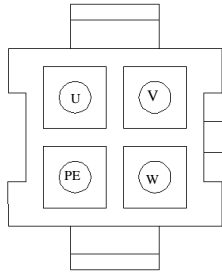

Name	Cable color	Function
U	Yellow	Drive input
V	Blue	Drive input
W	Red	Drive input
PE	Yellow-green/black	Grounding

b) 4-core power aviation plug

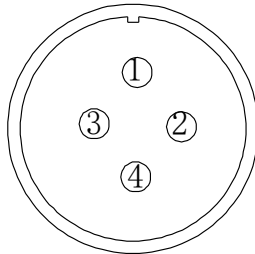

No.	Name	Function
1	PE	Grounding
2	U	Drive input
3	V	Drive input
4	W	Drive input

c)Braking cable plug

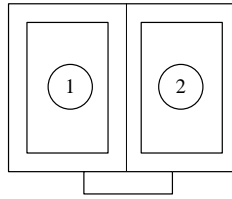

No.	Name	Function
1	+	DC 24V +
2		DC 24V -

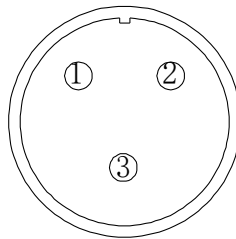

Plug No.	Name	Function
1	+	DC 24V +
2	-	DC 24V -
3	—	None

4.5 EMC

4.5.1 Definition

Electromagnetic compatibility (EMC) describes the ability of electronic and electrical devices or systems to work properly in the electromagnetic environment and not to generate electromagnetic interference that influences other local devices or systems.

In other words, EMC includes two aspects: The electromagnetic interference generated by a device or system must be restricted within a certain limit; the device or system must have sufficient immunity to the electromagnetic interference in the environment.

4.5.2 Installation Environment

The system manufacturer using the servo drive is responsible for compliance of the system with the European EMC directives. Based on the application of the system, the integrator must ensure that the system complies with standard EN 61800-3: 2004 Category C2, C3 or C4.

The system (machinery or appliance) installed with the servo drive must also have the CE mark. The system integrator is responsible for compliance of the system with the EMC directives and standard EN 61800-3: 2004 Category C2.

If applied in the first environment, the servo drive may generate radio interference. Besides the CE compliance described in this chapter, users must take measures to avoid such interference, if necessary.

4.5.3 Selection and Installation of Peripheral EMC Devices

An EMC filter installed between the servo drive and the power supply can not only restrict the interference of electromagnetic noise in the surrounding environment on the servo drive, but also prevent the interference from the servo drive on the surrounding equipment. FL20 works with external filter and input filter according to different power rating. The installation precautions are as follows.

- 1) Strictly comply with the ratings when using the EMC filter. The EMC filter is category I electric apparatus, and therefore, the metal housing ground of the filter should be in good contact with the metal ground of the installation cabinet on a large area, and requires good conductive continuity. Otherwise, it will result in electric shock or poor EMC effect.
- 2) The ground of the EMC filter and the PE conductor of the servo drive must be tied to the same common ground. Otherwise, the EMC effect will be affected seriously.
- 3) The EMC filter should be installed as closely as possible to the power input side of the servo drive.

4.5.4 Shielded Cable

The shielded cable must be used to satisfy the EMC requirements of CE marking. The Shielded cable are shown in the following figure

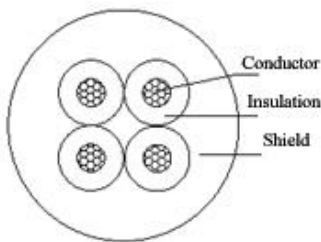

To suppress emission and conduction of the radio frequency interference effectively, the shield of the shielded cable is cooper braid. The braided density of the cooper braid should be greater than 90% to enhance the shielding efficiency and conductivity, as shown in the following figure.

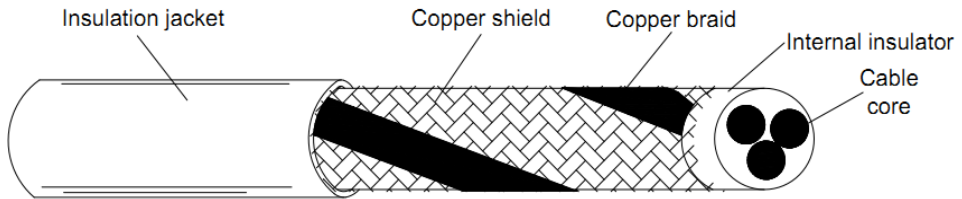

The installation precautions are as follows:

- 1) Symmetrical shielded cable is recommended. The four-conductor shielded cable can also be used as an input cable.
- 2) The motor cable and PE shielded conducting wire (twisted shielded) should be as short as possible to reduce electromagnetic radiation and external stray current and capacitive current of the cable. If the motor cable is over 100 meters long, an output filter or reactor is required.
- 3) It is recommended that all control cables be shielded.
- 4) The motor cables must be laid far away from other cables. The motor cables of several servo drives can be laid side by side.
- 5) It is recommended that the motor cables, power input cables and control cables be laid in different ducts. To avoid electromagnetic interference caused by rapid change of the output voltage of the servo drive, the motor cables and other cables must not be laid side by side for a long distance.
- 6) If the control cable must run across the power cable, make sure they are arranged at an angle of close to 90°. Other cables must not run across the servo drive.
- 7) The power input and output cables of the servo drive and weak-current signal cables (such as control cable) should be laid vertically (if possible) rather than in parallel. The filter, servo drive and motor should be connected to the system (machinery or appliance) properly, with spraying protection at the installation part and conductive metal in full contact.

V. Operation and parameters

5.1 Keypad description

5.1.1 Instruction of keypad

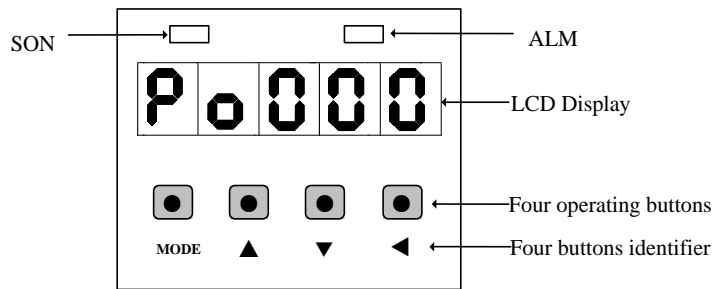

Fig 5-1-1 Digital keypad

Identifier	Name	Function
SON	Charge LED (green)	Indicating that Servo is on.
ALM	Charge LED (red)	Indicating that malfunction occurs.
PANAL	LCD Display	The LCD display (5-digit, 7-step display panel) shows the monitor codes, parameter settings and operation values of the AC servo drive.
MODE	Mode key	1 Switching between function groups. 2 Displaying malfunction codes in turn.
▲ (UP)	UP key	1 Pressing UP key to increase the display value. 2 Continuously pressing UP key for 0.5s to increase setting value slowly. 3 Continuously pressing UP key for 1s to increase setting value rapidly. 4 Used to forward start in jogging run.
▼ (DOWN)	DOWN key	1 Pressing DOWN key to decrease the display value. 2 Continuously pressing UP key for 0.5s to decrease setting value slowly. 3 3 Continuously pressing UP key for 1s to decrease setting value rapidly. 4 Used to reverse start in jogging run.
◀ (SET)	shift/set key	1 Continuously pressing this key for 0.5s to enter into parameter setting mode 2 Pressing this key can move the cursor to the left and then change parameter settings (blinking digits) by using arrow keys. 3 Continuously pressing this key for 0.5s to confirm and set current value into

		the parameter. 4 Continuously pressing this key for 2s to reset the malfunction.
--	--	---

5.2 Keypad operating procedure

5.2.1 Switchover between parameter section

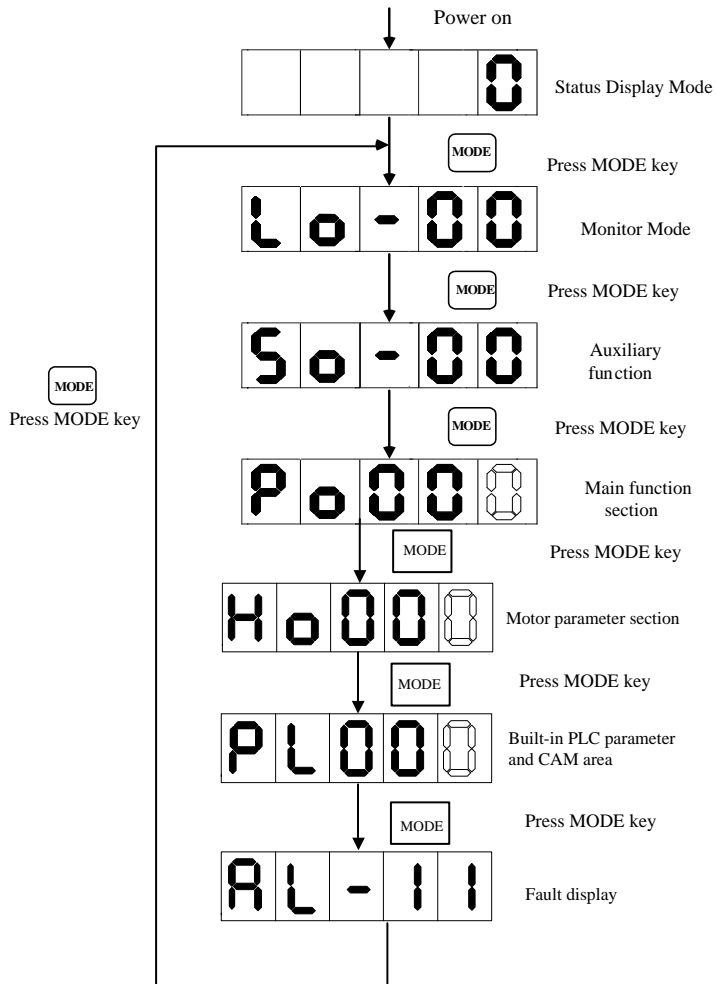

Fig 5-2-1 Switchover between parameter section

After main circuit is powered on, servo status display So-09 is displayed in the keypad, the Mfr's value of which

is servo output speed. The display content will switch among monitor function section (Lo-□□), auxiliary function section (So-□□), main function section (Po□□□), motor parameters section (Ho□□□) and high-speed counting section (PL□□□) by pressing MODE key.

If fault occurs, current fault code will be displayed circularly.

5.2.2 Parameters instructions

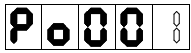

The representation method in this manual is Po001.

The hollow digitron represents blinking operating digits, which is the adjustable digits.



In this manual, three parameters modes is adopted to introduce the parameters.



□□□□□ represents five operating digits in keypad.

■ one parameter mode (if no special instruction, the parameters belong to this mode)

□□□□□one parameter mode means that five digits represent one parameter.

Q

For example:

Ex 1: Po113 internal speed given 1 is 1000r/min, the display content is:



(The unit is 0.1 r/min) The quoting mode is Po113=1000.

Ex 2: Po114 internal speed given 2 is -1000r/min, the display content is:

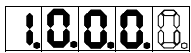

(The unit is 0.1 r/min) The quoting mode is Po114=-1000.

Note: if all decimal points are lit, the current value is negative value.

■ Two parameters mode

d □□□□Two parameters mode means every two digits except the first digit is an adjustable parameter digit.

Y X

X and Y represent an adjustable parameter digit separately.

For example:

Ex: Po407 CN3-5 terminal function is alarm-reset. The display content is:

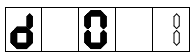

The quoting mode is Po407.X=1.

■ Four parameters mode

b □□□□Four parameters mode means each digit except the first digit is an adjustable parameter digit.

D C B A

A, B, C and D represent an adjustable parameter digit separately.

Ex: at position mode, the pulse command type of pulse+pulse is selected, then the last digit of Po300 is set to 1.

The display content is:

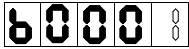

The quoting mode is Po300.A=1.

■ Five parameters display

□□□□□ The first digit means current page, the other digits mens current value.

E D C B A

For example: set value of HOME, Po136=131072, the actual display content is as below:

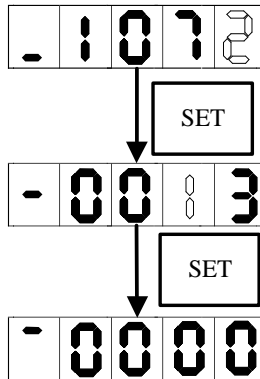

Po001	Input source of control mode and control command			
			Speed	Position
				Torque
	Setting range	Setting unit	Mfr' s value	When Enabled
	Two parameters	N/A	1 0	After restart

Parameter scope

Parameter

Name

Indicates setting range for the parameter.

The unit of parameter

Indicates parameter value before shipment (Factory setting).

Indicates if the power has to be turned OFF and ON again to validate setting changes.

Note: parameter scope means control mode for which the parameter is available

Speed means speed mode; **Position** means position mode; **Torque** means torque mode.

5.3 keypad operating procedure

5.3.1 Example of monitor function parameter

Take usage of Lo-14(DI8~DI5 status display) as the example:

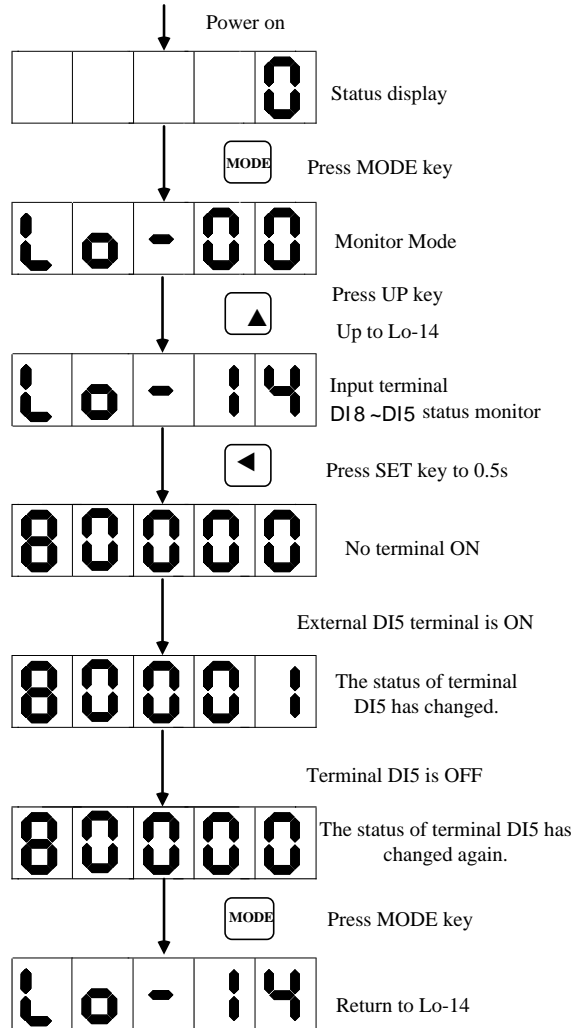

Fig 5-3-1 Monitor terminal status mode

5.3.2 Example of auxiliary parameters usage

Take usage of So-14 (JOG run) as the example:

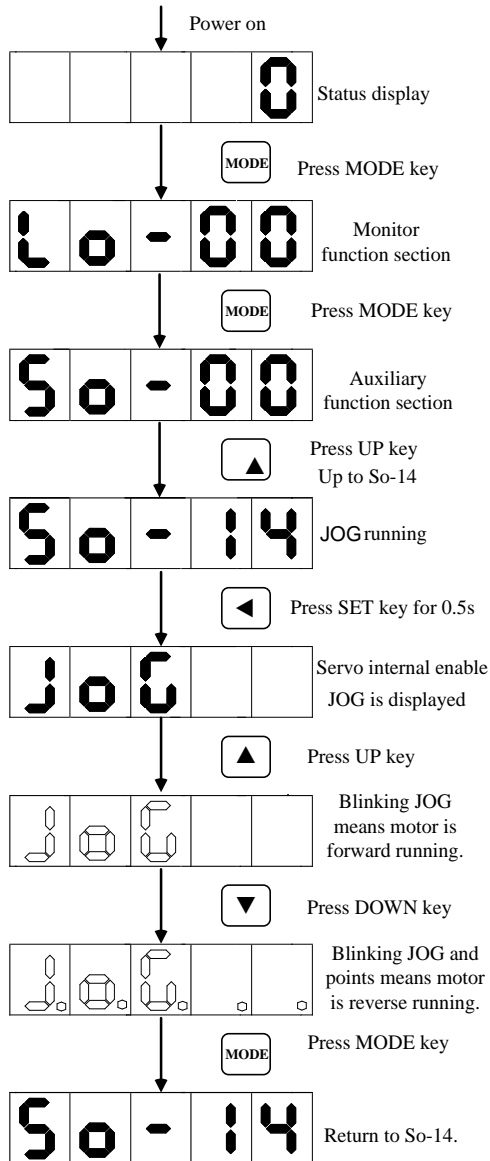

Fig 5-3-2 Jog run

5.3.3 Parameter setting

Take setting parameter Po001 as the example:

When Po001.Y=0, set motor rotating clockwise to forward direction. When Po001.X=3, analog speed mode is selected.

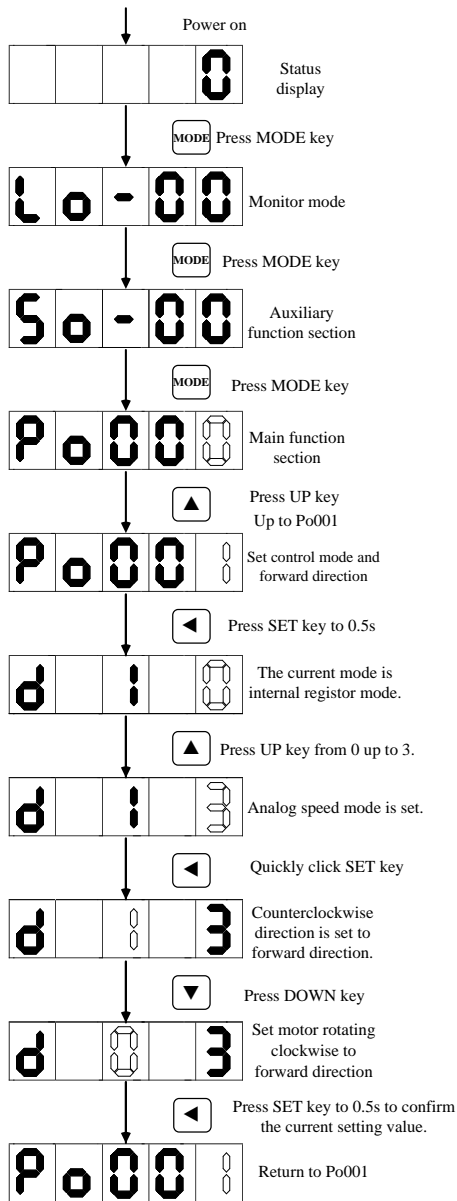

Fig 5-3-3 Parameter setting procedure

If function code digits are longer than 5 digits, the setting method is as below:

Take setting Po123 to 10000000 as example:

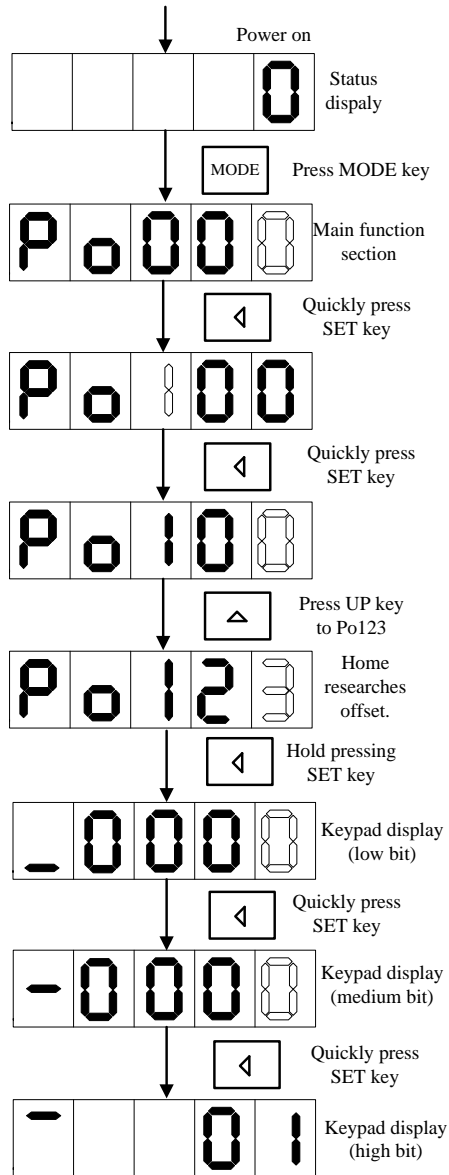
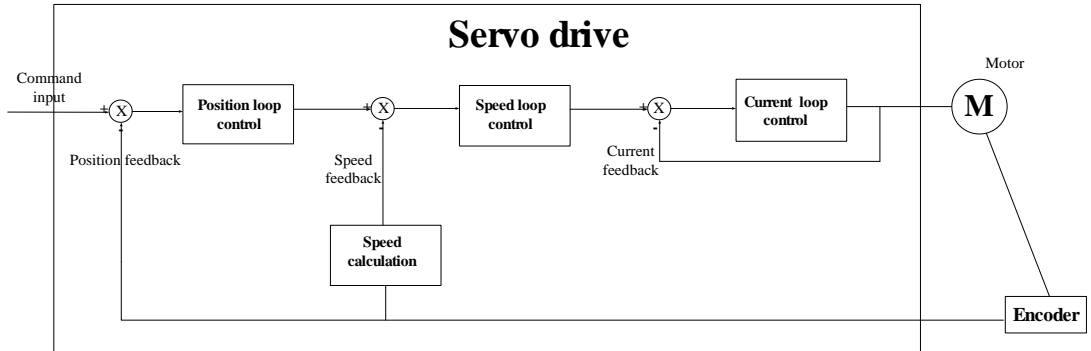

Fig 5-3-4 Parameter setting procedure

Servo system includes servo drive, servo motor and encoder.



Based on the command modes and running characteristics, servo drives supports three running mode, position control, speed control and torque control.

In the position control mode, motor target position is confirmed by position command total numbers. The position control mode strictly controls the position and speed, and is often used in the positioning device. It is the most commonly used mode of the servo drive, applicable to the mechanical arm, moulder, engraving and milling machine, and computer numerical control (CNC) machine tool.

In the speed control mode, the speed is controlled by AI setting, DI setting, or communication setting. It is often used in scenarios with constant speed. For example, for the analog engraving and milling machine, the host controller uses the position mode, and the servo drive uses the speed control mode.

In the torque control mode, the torque is changed by changing the analog setting or the address value by means of communication. This mode is mainly applied to the winding and unwinding devices with strict tension requirements.

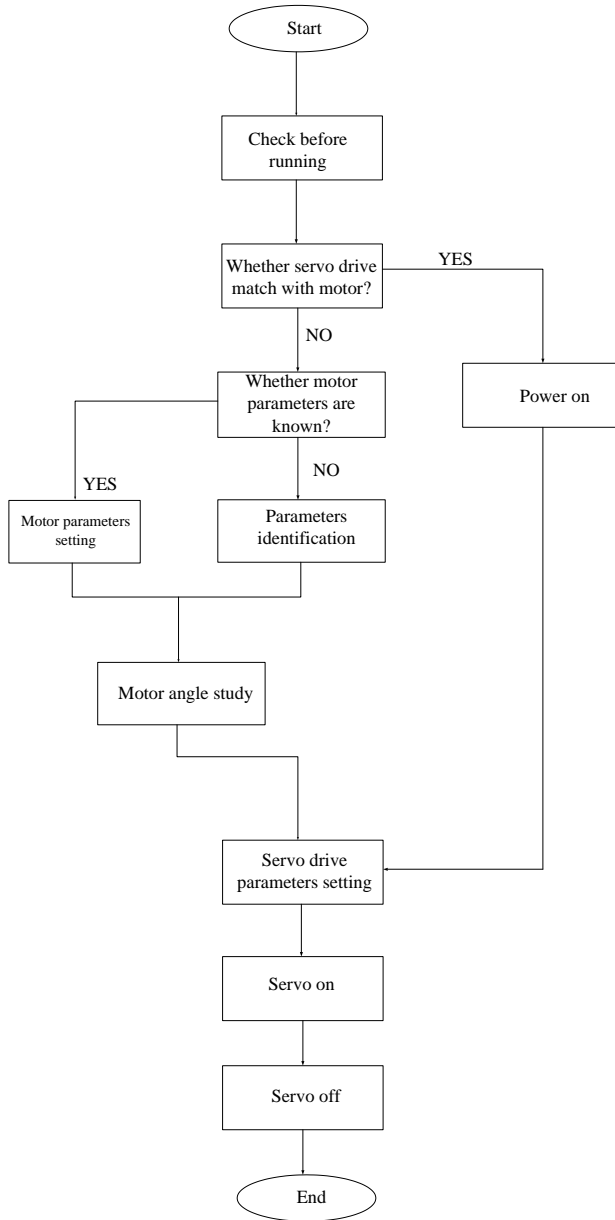

Note:

Please make sure servo motor runs normally without load, then connect load to motor.

After a servo motor is changed, if user does not know encoder electric angle and whether motor phase sequence is correct, user can make the servo motor operate normally by using electric angle indication function. Before electric angle indication, please make sure the following steps:

- (1) Motor actual power.
- (2) Make sure servomotor encoder cable is connected correctly.
- (3) Make sure servomotor is connected to zero.
- (4) Make sure servo is in the OFF status.

When So-25=3, please input motor actual power to servo drive, then identify parameters.

Ho011	Motor power			Speed	Position	Torque
	Setting range	Setting unit	Mfr's value	When enabled		
	1~30000	0.01KW	—	Effective Immediately		

So-25	Electric angle identification				Speed	Position	Torque
	Setting range	Setting unit	Mfr's value	When enabled			
	0~10	N/A	0	Effective Immediately			
	0: no motor parameter identification						
	1: identify motor resistor, inductance, pole pairs numbers and encoder installation angle						
2: lock motor shaft							
3: identify motor resistor, inductance and estimate motor EMF							
4: identify motor resistor, inductance, pole pairs numbers, motor EMF and encoder installation angle							
5-8: reserved function.							
9: Cogging torque compensation function, please refer to Chapter 6.6.10.							
10: Friction torque compensation, please refer to Chapter 6.6.11.							

When So-25 is set to 1, enter So-14 jogging control mode (refer to 6.1.5). System starts automatic testing, panel displays flashing "TEST". After identification is finished, panel will return to So-14 interface, and electrical angle is saved in Ho018. If line sequence error occurs, panel displays AL-05, please stop the motor and adjust the line sequence before next operation.

 Attention: When line sequence error occurs, reverse two phases, and then repeat the electrical angle identification.

6.1 Basic parameters setting

6.1.1 Before running

Make sure that all wiring has been completed.

Wiring		
1	Connect L1 (R)、L2 (S)、L3 (T) of servo drive to main circuit power.	
2	Connect U/V/W of servo drive to U/V/W of servo motor well.	
3	Check all control signal cables are connected correctly, and check the brake, overtravel and the other protective functions for correct operation.	
4	Servo drive and servo motor must be grounded reliably.	
5	When external resistor is used, please remove short wires between B2 and B3.	
Environment and machinery		
1	There is no iron dust or foreign matter in the servo drive.	
2	There is no inflammable substance nearby servo drive and external braking resistor.	
3	Servo motor is reliably connected to mechanical equipment.	

6.1.2 Power on

1) Power on control circuit and main circuit.

Pease connect power to L1 (R)、L2 (S)、L3 (T) .

- Power on control circuit and main circuit, if bus voltage indicator shows no abnormal, and “0” is displayed in the keypad, it indicates servo drive is enabled.
- If “AL-xx” is displayed in the keypad, please refer to Chapter 9.

2) Set S-ON to OFF status.

Please set DI terminal of servo drive to FunIN. 1: S-ON, and make sure the DI terminal is valid. Then set DI terminal to invalid status by PC/PLC or external switch.

6.1.3 Parameters setting

1) Motor parameters

The parameters of the motor include: rated voltage, rated current, encoder lines, rated rotary speed , numbers of pole pairs ,phase resistance, inductance, Movement of inertia, back EMF, line voltage ,etc. Please confirm that the

parameter's setting value is identical to the motor's parameter to ensure motor normal operation, in case of burning servo system out. When So-48 is set to 1, the motor's parameters can be changed. The parameter functions are as following:

	Motor parameter setting		speed	position	torque
	Function Code	Function Definition (unit)	Setting range	Function	When enabled
Motor parameters	Ho000	Rated voltage (V)	0~30000	rated voltage	Effect Immediate
	Ho001	Rated current (0.1A)	0~30000	rated current	Effect Immediate
	Ho002	Max rotary speed(r/min)	0~32000	Max rotary speed	Effect Immediate
	Ho003	Rated rotary speed (r/min)	0~32000	rated rotary speed	Effect Immediate
	Ho004	Pole-pairs (pair)	1~30	pole-pairs	Effect Immediate
	Ho005	Phase resistance ($10^{-3}\Omega$)	0~65535	phase resistance	Effect Immediate
	Ho006	D-axis inductance ($10^{-6}H$)	0~65535	D-axis inductance	Effect Immediate
	Ho007	Q-axis inductance ($10^{-6}H$)	0~65535	Q-axis inductance	Effect Immediate
	Ho008	Back EMF line voltage effective value ($0.1V/1000$ r/min)	0~30000	back EMF line voltage effective value	Effect Immediate
	Ho012	Motor rotary inertia ($10^{-6}Kg\cdot m^2$)	0 ~ 2147483647	motor rotary inertia	Effect Immediate
	Ho016	Encoder resolution (ppr)	0 ~ 2147483647	Encoder resolution	Effect Immediate
	Ho018	Encoder installation angle(pulse numbers)	-2147483647 ~ +2147483647	Encoder installation angle(pulse numbers)	Effect Immediate
	Ho121	Over-load sensitivity	1~30000	over-load sensitivity	Effect Immediate

Motor parameters can be set according to the table, in addition, pay attention to the following points in use:

- (1) When So-48=1, the H group parameters can be set. After electrical degree identification is finished, the installation angle of the encoder is saved in Ho011. Please refer to chapter 6 for operating method of electrical degree identification.
- (2) Different motor parameter corresponds to different servo motor, make sure the parameters are in accordance with the motor's before using.
- (3) Changing Ho121 can advance overload protection of servo motor or put it off. The larger the Ho121, the longer the overload protection time.
- (4) Motor parameters are set by manufacturer. Please do not change it by yourself. If system is damaged because user sets wrong motor parameter or changes no-standard motor, user should take the consequences.

2) Switching the Servo motor Rotation Direction

The default setting for "forward rotation" is counterclockwise as viewed from the servo motor shaft. The mfr's value of Po001.Y is 1. When Po001.Y is set to 0, the forward rotation is clockwise as viewed from the servo motor shaft.

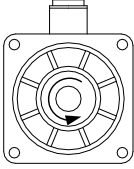
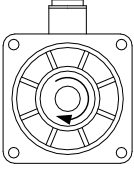
Po001.Y=1, forward rotation is counterclockwise.	Po001.Y=0, forward rotation is clockwise.
	

d. Holding brake setting

The holding brake is used when the servo motor controls a vertical shaft. The servo motor with brake prevents the movable part from shifting due to gravity when the power supply fails. The holding brake function is only suitable for servo motor with brake.

a)Wiring of holding brake

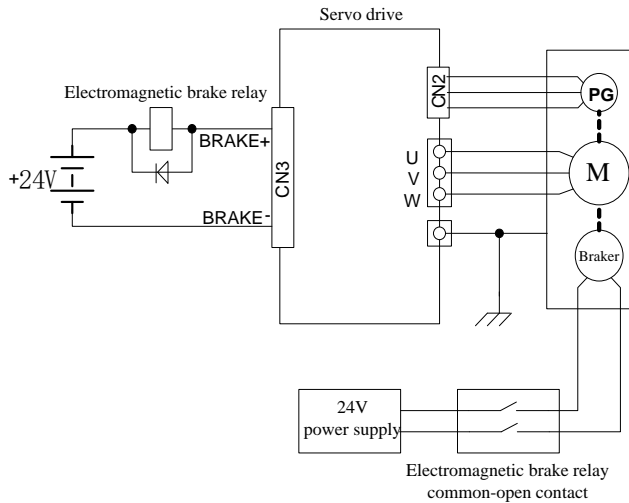

Note:

- 1. The internal electromagnetic is only valid when servo is in the stop status.**
- 2. The coil of electromagnetic has polarity, please distinguish them when wiring.**
- 3. The power supply of electromagnetic is supplied by users. The voltage is 24VDC (±10%) and the current should be selected according to nameplate of brake. And electromagnetic and control signal are forbidden using one power supply.**

b)Braking parameters setting

Signal name	Code	Terminals	Remarks
Electromagnetic braking control	BRAKE	BRAKE+ BRAKE -	Electromagnetic braking control output.

Braking work sequence is different for different drive status, which is divided into normal work status and power-off status.

1) Servo drive works in normal status.

Normal status includes servo motor static status and servo motor running status.

▪Static status: motor actual speed is lower than 20r/min.

▪Running status: motor actual speed is higher than 20r/min.

a) Braking when servo motor stops

So-02	Delay time for SERVO OFF			Speed	Position	Torque
	Setting range	Setting unit	Mfr's value	When enabled		
	0~500	10ms	0	Effective Immediately		

So-16	Speed threshold of electromagnetic braking			Speed	Position	Torque
	Setting range	Setting unit	Mfr's value	When enabled		
	0~30000	0.1r/min	1000	Effective Immediately		

Note: the value of So-16 should not be set too high, please use the Mfr's value.

When servo motor stops or the motor speed is lower than So-16, if enable signal is OFF and electromagnetic braking signal is invalid, after the time set by So-02, servo will be in the disable status.

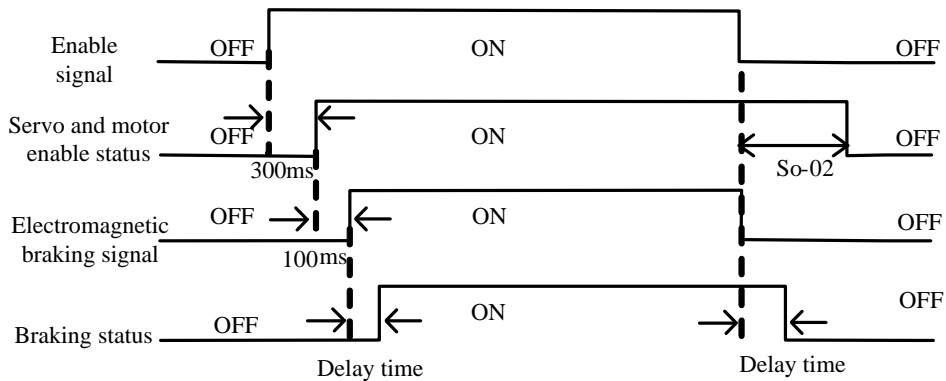

Fig 6-3-1 Electromagnetic brake sequence diagram

Note: if some alarms occur, servo will turn to disable status, So-02 will be invalid.

b) Braking when servo motor is rotating.

So-03	Delay time for electromagnetic braking stop			Speed	Position	Torque
	Setting range	Setting unit	Mfr's value	When enabled		
	10~100	10ms	50	Effective Immediately		

When servo motor is rotating and speed is higher than So-16, after alarm occurs, servo drive will become disable status Immediate, servo motor will free stop. When any of below items occurs, braking signal will be closed:

1. Speed decreases to setting value of So-16.
2. Servo drive becomes disabled status, and after delay time of So-03.

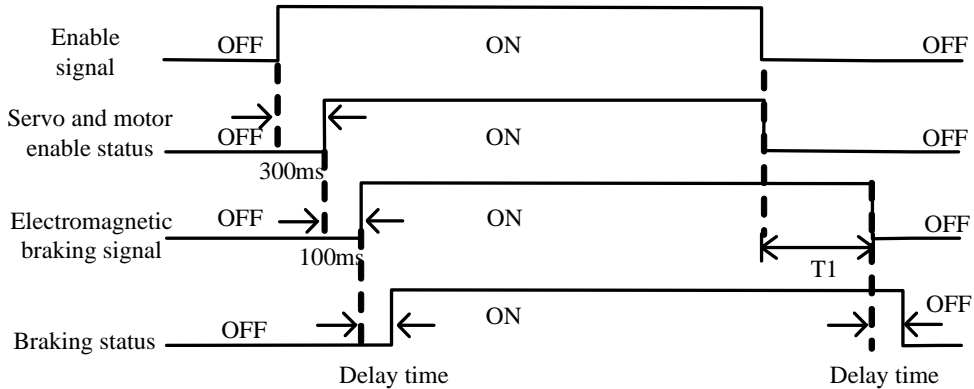

Fig 6-1-4 Electromagnetic brake sequence diagram

Note: after servo enabled is off, T1 is the lower value of So-03 and the time taken by speed arriving to setting value of So-16.

6.1.4 Setting the Overtravel Limit Function

Overtravel limit function prohibit movable machine parts from exceeding the allowable range of motion. A limit switch, a photoelectric switch or encoder multi-turn number should be adopted for detection.

1. Hardware overtravel protection function

As soon as the servo drive detects the on/off signal from the limit switch, it will force the speed in the present direction to turn to 0, but it does not work for the speed of opposite direction.

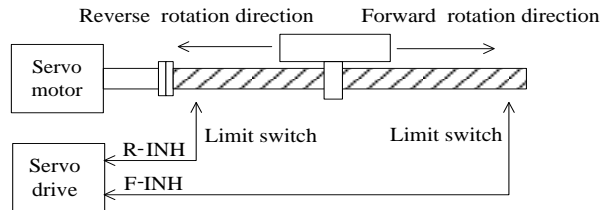

Fig 6-1-5 Overtravel Limit Function

(1) Input signal

Signal name	Code	Default terminal	Remarks
Forward run prohibited	F-INH	CN3-9	Forbidden servo drive forward run.
Reverse run prohibited	R-INH	CN3-8	Forbidden servo drive reverse run.

(2) Setting related parameter

So-17	Forward run prohibited Speed Position Torque			
	Setting range	Setting unit	Mfr's value	When enabled
	0: Prohibited invalid 1: Prohibited valid	N/A	1	Effective Immediately

So-18	Reverse run prohibited Speed Position Torque			
	Setting range	Setting unit	Mfr's value	When enabled
	0: Prohibited invalid 1: Prohibited valid	N/A	1	Effective Immediately

(1) Enabled the overtravel signal

When So-17=1, So-18=0 and external control terminals with the function of F-INH and R-INH are allocated, the overtravel function is enabled. For security, the default setting of So-17 and So-18 are prohibited valid and the signal input type is common-close contact. So even malfunction occurs, the overtravel protection is still valid.

(2) Disable the overtravel signal

When So-17=0 and So-18=0, the overtravel function is disable. If the input terminals with the function of F-INH and R-INH are not allocated, the overtravel function is disabled.

(3) Setting the stop torque for overtravel

Po207	Forward/reverse run prohibited torque And emergency stop torque			
	Setting range	Setting unit	Mfr's value	When enabled
	1~300	1% of rated torque	100	Effective Immediately

When forward/reverse run prohibited signal or emergency stop signal is valid, the max value of instantaneous reverse stop torque of servo motor is limited within the range of this value, and this value is an absolute value, it works on both forward run and reverse run.

Po216	Forward/reverse run prohibited torque setting torque			
	Setting range	Setting unit	Mfr's value	When enabled
	0~1	N/A	1	Effective Immediately

When Po216=0, the actual reverse limit torque is the setting torque in Po207;

When Po216=1,torque limit value is 0.

2. Software overtravel protection function

Once encoder multiturn position is detected to exceed setting range, alarm will occur. Take “Home” as initial position, servo motor can move between movement range set by forward/reverse. If servo motor exceeds movement range, servo drive will trip into AL-27.

The related parameters are as below:

Po140	Forward running range pulse when overtravel protection Speed Position Torque			
	Setting range	Setting unit	Mfr's value	When enabled

	0~2147483647	N/A	0	Effective Immediately
Po142	Forward running range multi-loop numbers when overtravel protection			<input type="checkbox"/> Speed <input type="checkbox"/> Position <input type="checkbox"/> Torque
	Setting range	Setting unit	Mfr's value	When enabled
	0~32000	N/A	1000	Effective Immediately
Po143	Reverse running range pulse when overtravel protection			<input type="checkbox"/> Speed <input type="checkbox"/> Position <input type="checkbox"/> Torque
	Setting range	Setting unit	Mfr's value	When enabled
	0~2147483647	N/A	0	Effective Immediately
Po145	Reverse running range multi-loop numbers when overtravel protection			<input type="checkbox"/> Speed <input type="checkbox"/> Position <input type="checkbox"/> Torque
	Setting range	Setting unit	Mfr's value	When enabled
	0~32000	N/A	1000	Effective Immediately
So-39	Overtravel limit function			<input type="checkbox"/> Speed <input type="checkbox"/> Position <input type="checkbox"/> Torque
	Setting range	Setting unit	Mfr's value	When enabled
	0: Invalid 1: Valid 2: stop but no alarm	N/A	1	Effective Immediately

- (1) First, set mechanical origin referring to 6.4.9, take mechanical origin as initial position, set forward and reverse running range.
- (2) Set So-39=0, software overtravel limit is invalid.

6.1.5 Jog operation procedure

Servo is at a special speed mode while jogging operation.

1) Panel jog function

Step	Content	Remarks
1	Check wiring of main circuit, check whether power supply of control circuit (L1C, L2C) and main circuit (R/L1, S/L2, T/L3) is powered on.	L1C and L2C should not be connected for 380 V servo drive
2	Press MODE key, to enter auxiliary function section So-□□	Please refer to 5.2.1
3	Press UP or DOWN key to find So-13 (Jog speed)	The Mfr's value is 100r/min
4	Press SET key for 0.5s to enter setting interface, to set safety value of jog speed by press UP or DOWN key.	Note: the unit of speed is 0.1r/min.
5	Press SET key for 0.5s to confirm the setting speed, and return to So-13.	
6	Press UP key to display So-14 (jog run)	
7	Press SET key for 0.5s to jog run.	JOG is displayed, servo is enabled.
8	Press UP key to jog forward run; press DOWN key to jog reverse run.	To confirm rotating direction.
9	Press MODE key, and servo is OFF, to quit JOG mode.	

So-13	Jog speed setting Speed Position Torque			
	Setting range	Setting unit	Mfr's value	When enabled
	0~30000	0.1r/min	1000	Effective Immediately

Note: 1. Internal jog mode is a special speed mode, the jog speed is related to deceleration time Po109, Po110.

2: Internal jog mode is not limited by forward/reverse prohibited, please make sure it is safe.

3: Please refer to 5.3.3 about procedure of internal jog operation.

2) Terminal jog function

Signal name	Name	Default terminal	Function
Terminal forward jog	JOGU	None	Forward jog is realized by controlling terminals.
Terminal reverse jog	JOGD	None	Reverse jog is realized by controlling terminals.

Note: The priority of jog mode is higher than the other modes.

1) When servo is OFF and terminal jog signal is valid, servo will run at jog mode.

2) If terminal jog signal is valid at any modes, servo will enter jog mode

6.1.6 Timing sequence control

(1) Timing sequence at power on

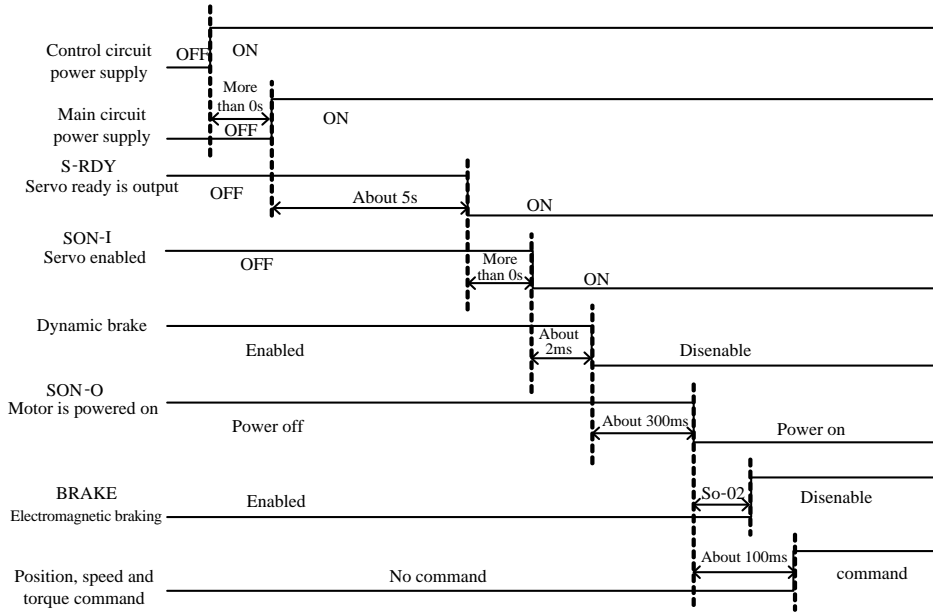

Fig 6-1-6 Sequence control after connecting the power supply

Note:

1. Above diagram is servo drive timing sequence from power-on to receiving command
2. Servo ready is trouble-free output after CPU is reset and main power is connected,.
3. Before servo drive is ready, main power should be connected and all control signal be ignored.
4. When So-07 =0 or 1, after servo on is ready, please wait for at least 100ms before sending control signal, otherwise control signal might be ignored.
5. When So-07= 2, after servo on is ready, please wait for at least 10ms before sending control signal, otherwise control signal might be ignored.

(2) Timing sequence when servo drive alarms

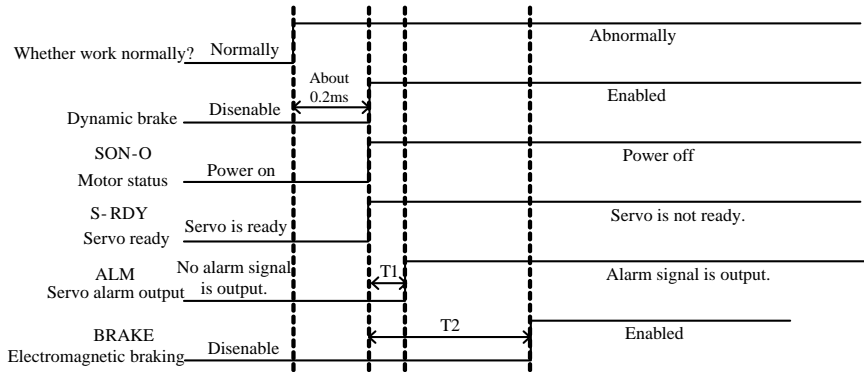

Fig 6-1-7 Timing sequence after alarm

- Note:
1. T1 value range is 0.1ms~20ms, determined by alarm type.
 2. T2 is electromagnetic braking time, taking the smaller value between So-03 and So-16.

(3) Timing sequence after alarm is reset

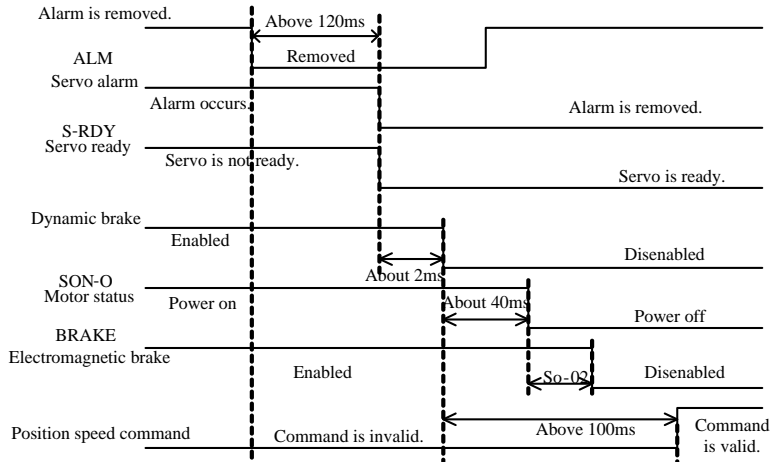

Fig 6-1-8 Timing sequence after alarm is reset

Note: when alarm occurs, servo drive is reset and then continues running, timing sequence is as Fig 6-1-8.

6.1.7 Setting the braking

The braking types of servo drive include three kinds: 1.dynamic braking 2.energy-consumption braking 3. Electromagnetic braking.

! Caution

- ★ Energy-consumption braking is valid after main circuit is powered on.
- ★ Electromagnetic braking starts after servo OFF. If it is not, overload malfunction will occur.
- ★ Dynamic braking starts after servo OFF or main circuit is powered off. But if motor rotation speed is too high, dynamic braking resistor will be overheat.

(1) Dynamic braking

Dynamic braking is a common way to stop servo motor. It is a kind of special energy-consumption braking mode. The braking circuit includes dynamic braking resistor and diode. The method of dynamic braking is to short-connect drive line coil of servo motor, to shorten motor mechanical feed distance by modes of energy consumption braking finally.

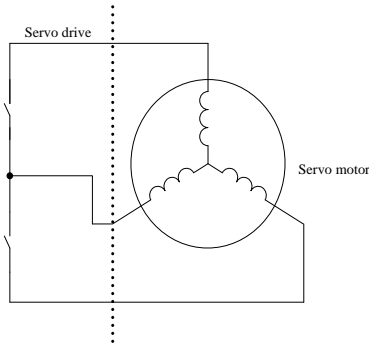

Fig 6-1-9 Dynamic braking

1) Setting function

So-07	Servo OFF stop mode			Speed Position Torque
	Setting range	Setting unit	Mfr's value	When enabled
	0: Coast stop		0	Effective Immediately
	1: Dynamic braking			
2: Fast enable				

Fast enable: after servo is power on, relay is switched on. After enable signal is valid, servo will be ON after 10ms.

2) Related parameter

So-08	Dynamic braking delay time			Speed Position Torque
	Setting range	Setting unit	Mfr's value	When enabled
	100~30000	0.1ms	5000	Effective Immediately

(2) Energy consumption braking

Motor is in the state of energy regeneration during deceleration or stop process, which converts mechanical energy into electrical energy. The energy feedback works on bus line by inverting circuit, which leads to the voltage of bus line higher. When the voltage is too high, the components in the servodrive will be damaged. The method of energy consumption braking is to consume feedback energy into heat energy by braking resistor.

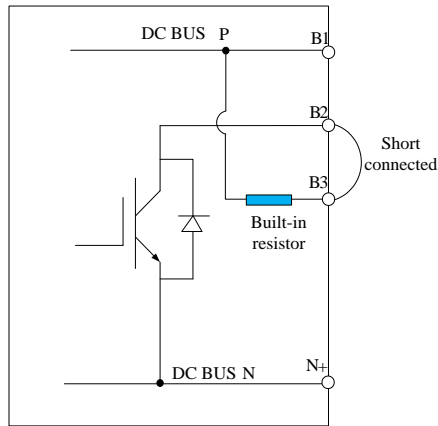

Fig 6-1-10 Wiring of energy consumption braking

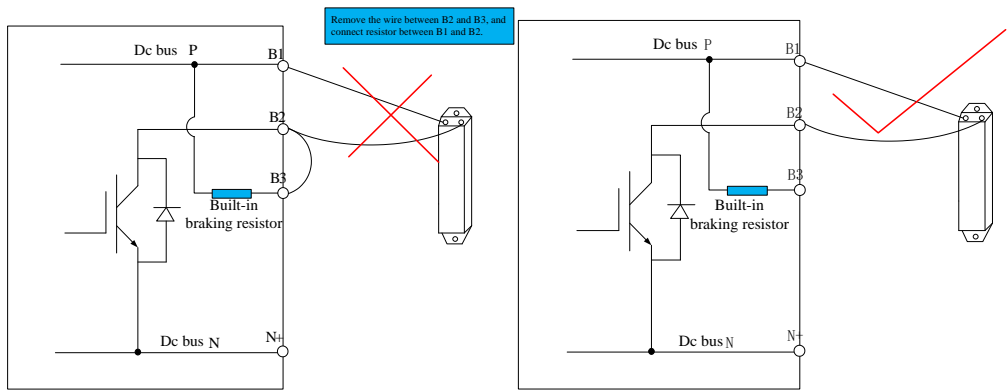

Fig 6-1-11 Wiring of braking resistor

Some servo drives have built-in braking resistor, if users need to use external braking resistor, please set the following both parameters:

So-04	Resistance value of braking resistor			Speed	Position	Torque
	Setting range	Setting unit	Mfr's value	When enabled		
	8~1000	Ω	—	Effective Immediately		

So-05	Discharge duty ratio			Speed	Position	Torque
	Setting range	Setting unit	Mfr's value	When enabled		
	0~100	%	50	Effective Immediately		

Please refer to next table for built-in braking resistor and min resistor value of external braking resistor for 220V servo.

Servo drive structure code	Built-in resistor value and power	Min resistor value of external braking resistor	Specification of external braking resistor
M1	None	40Ω	60Ω/200 W
M2	50W/50Ω	25Ω	40Ω/ 400 W
M3	100W/20Ω	15Ω	15Ω/ 1000 W

Please refer to next table for built-in braking resistor and min resistor value of external braking resistor for 380V servo.

Servo drive structure code	Built-in resistor value and power	Min resistor value of external braking resistor	Specification of external braking resistor
M2	50W/50Ω	50Ω	50Ω/1000W
M3	100W/60Ω	50Ω	50Ω/1000W
MM4/M4	—	40Ω	40Ω/1000W
M5	—	20Ω	20Ω/1000W
M6	—	20Ω	20Ω/2200W

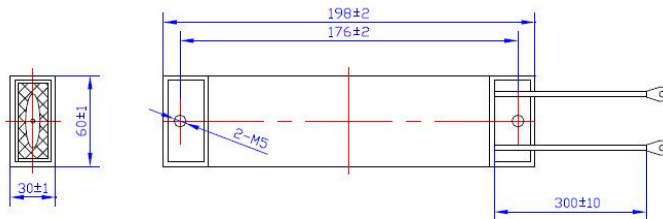

Fig 6-1-12 Wiring of braking resistor

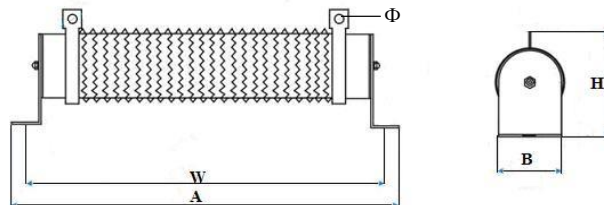

Fig 6-1-13 Wiring of braking resistor

Resistor power	External dimension (mm)			Installation dimension (mm)		Resistor type
	Length (A)	Width (B)	Height(H)	Length (W)	Aperture (Φ)	
500W	360±3.0	50±1.0	91±3.0	338±3.0	Φ6.5±0.3	Non-sense ripple porcelain tube resistor
1kW	350±3.0	60±2.0	119±3.0	325±5.0	Φ6.5±0.3	Non-sense ripple porcelain tube resistor
1.5kW	484±5.0	68±1.0	125±3.0	454±4.0	Φ6.5±0.3	Non-sense ripple porcelain tube resistor
2kW	557±5.0	60±1.0	119±3.0	532±4.0	Φ6.5±0.3	Non-sense ripple porcelain tube resistor
4kW	587±5.0	70±1.0	210±5.0	559±4.0	Φ6.5±0.3	Double tube vertical non-sense ripple porcelain tube resistor
6kW	661±5.0	70±1.0	210±5.0	633±4.0	Φ6.5±0.3	Three tube vertical non-sense ripple porcelain tube resistor
9kW	660±5.0	260±1.0	133±5.0	635±4.0	Φ6.5±0.3	Three tube lateral non-sense ripple porcelain tube resistor
4kW	562±5.0	140±1.0	119±5.0	537±4.0*80	Φ6.5±0.3	Double tube lateral non-sense ripple porcelain tube resistor
6kW	562±5.0	220±1.0	119±5.0	537±4.0*160	Φ6.5±0.3	Three tube lateral non-sense ripple porcelain tube resistor
9kW	652±5.0	300±1.0	131±5.0	627±4.0*160	Φ6.5±0.3	Four tube lateral non-sense ripple porcelain tube resistor

(3) Electromagnetic braking

Electromagnetic braking is suitable for servo motor with brake, which can make sure machine not move because of self weight when servo is OFF.

6.2 Speed mode

6.2.1 Parameters setting

Speed mode is mostly used in CNC industry. FL20 series servo drive has two speed modes, analog speed mode and internal register speed mode. User can select it by Po001.

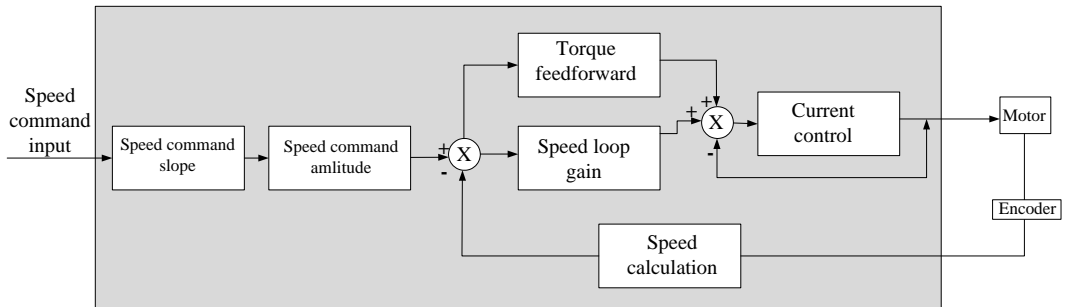

Fig 6.2.1 Speed mode control diagram

6.2.1 Parameters setting

Speed mode includes internal register speed and analog speed, user can set mode selection by Po001.

Parameter		Remarks
Po001	d □ 0	Control mode selection: internal register speed mode
	d □ 3	Control mode selection: analog speed mode



- ★ Connect power supply of servo main circuit, power supply of control circuit, motor power cable and encoder cable correctly.
- ★ Jog trial operation by keypad.
- ★ Refer to Fig 6.2.2 and Fig 6.2.3 to connect DI/DO.
- ★ Set the related parameters of speed mode.
- ★ Operating servo drive and make sure the running direction of servo motor is correct, and set related parameters of gain adjustment, please refer to Chapter 7.3.

1) Internal register speed mode

Two setting types are as below:

- 1) To set speed value to function code, then switch speed by SD-S1 and SD-S2 of DI terminal in CN3.
- 2) To change the value of function code by communication.

a) Wiring diagram

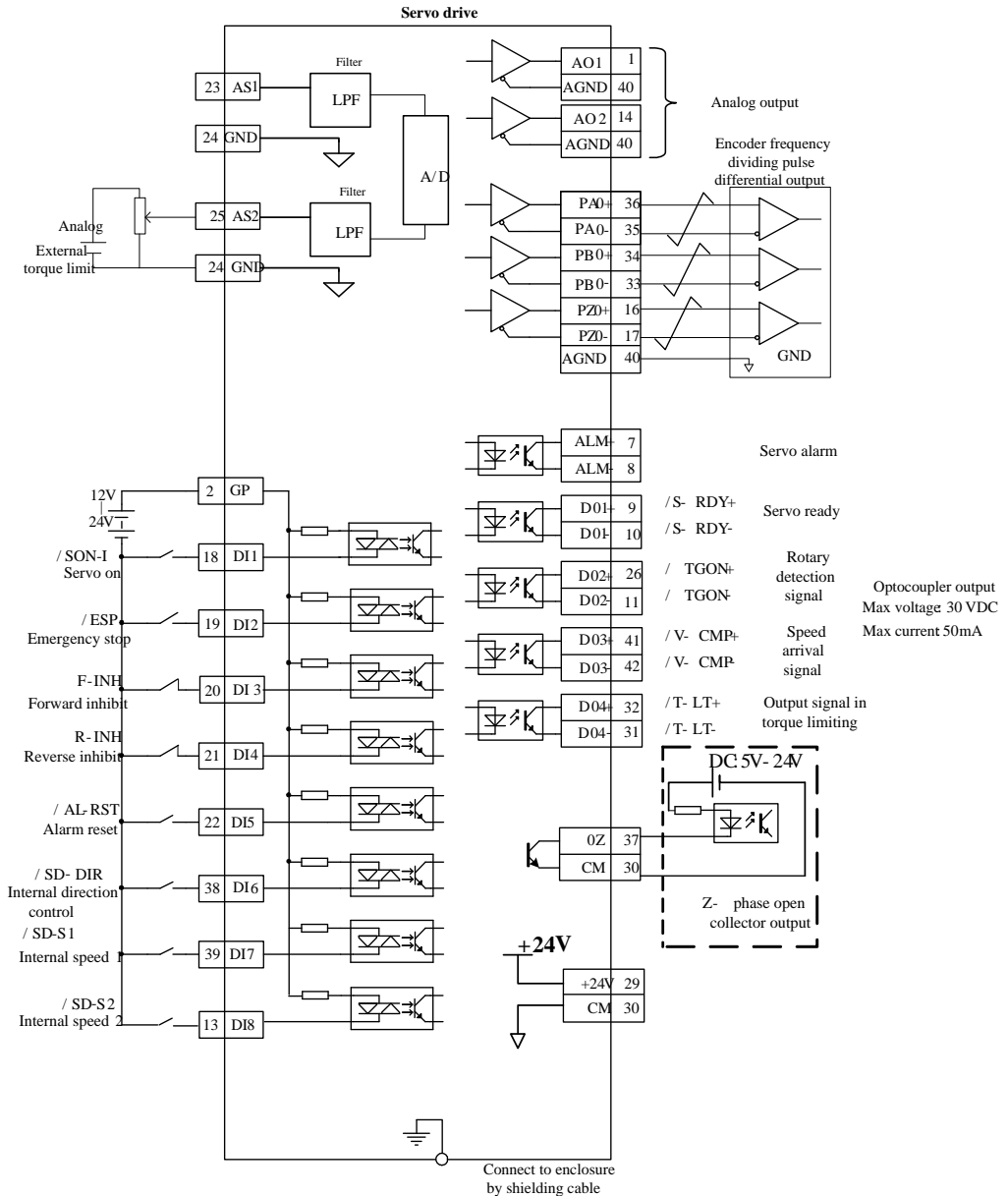

Fig6.2.2 Wiring of internal speed mode

Note:

1 represents twisted-pair wires.

2 Servodrive has internal 24 VDC power supply. But external 12~24VDC power supply is recommended.

3 DI1~DI8 are programmable input terminals, and DO1~DO4 are programmable output terminals. Users can

redefine these terminals by parameters.

b) Related parameters

Parameters		Remarks		
Po001	d □ 0	Control mode selection: internal register speed mode		
Po113	Internal speed given 1			Speed
	Setting range	Setting unit	Mfr's value	When enabled
	0~±32000	0.1r/min	1000	Effective Immediately
Po114	Internal speed given 2			Speed
	Setting range	Setting unit	Mfr's value	When enabled
	0~±32000	0.1r/min	2000	Effective Immediately
Po115	Internal speed given 3			Speed
	Setting range	Setting unit	Mfr's value	When enabled
	0~±32000	0.1r/min	3000	Effective Immediately

Note: when Po113, Po114, Po115 value exceed motor maximum speed, actual speed is motor maximum speed

c) Input signal setting

Signal name	Abbreviation	Default terminal	Remarks
Internal speed selection 1	SD-S1	CN3-39	Internal speed selection
Internal speed selection 2	SD-S2	CN3-13	
Internal speed direction control	SD-DIR	CN3-38	Internal speed direction control

d) Internal speed setting

Input signal			Motor rotation direction	Running speed
SD-DIR	SD-S1	SD-S2		
OFF	OFF	OFF	Forward	0: zero
	OFF	ON		Po113: internal speed given 1
	ON	OFF		Po114: internal speed given 2
	ON	ON		Po115: internal speed given 3
ON	OFF	OFF	Reverse	0: zero
	OFF	ON		Po113: internal speed given 1
	ON	OFF		Po114: internal speed given 2
	ON	ON		Po115: internal speed given 3

2) Analog speed mode

a) Wiring diagram

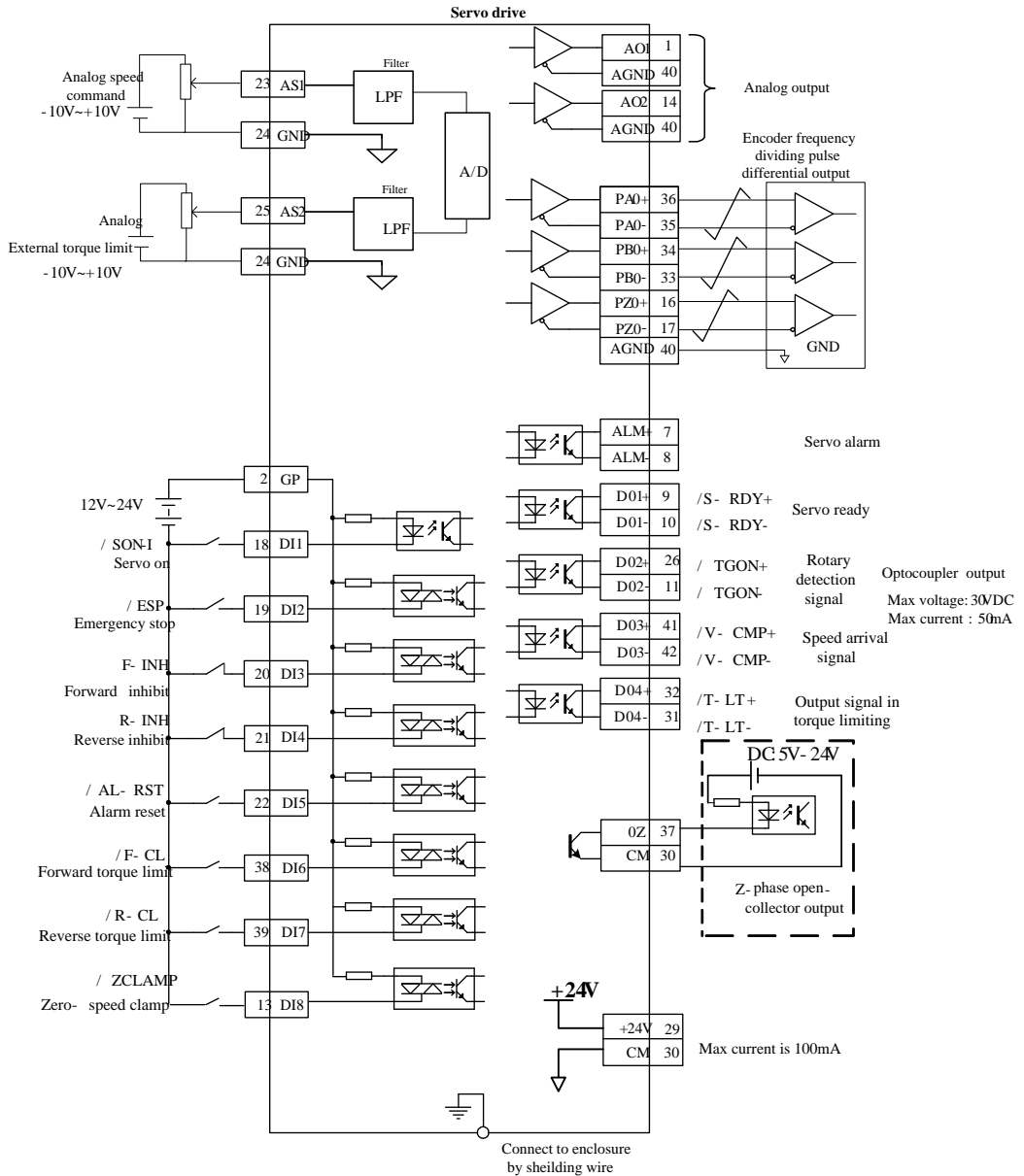



Fig 6.2.3 Connection of internal speed mode

Note:

1  represents twisted-pair wires.

2 Servodrive has internal 24 VDC power supply. But external 12~24VDC power supply is recommended.

3 DI1~DI8 are programmable input terminals, and DO1~DO4 are programmable output terminals. Users can redefine these terminals by parameter.

★Zero drift: when analog input voltage is 0, zero drift is relative value between servo drive sampling voltage and reference terminal.

Command source is acquired from servo drive terminal.

Automatic zero set: servo drive can compensate zero drift according to sample value.

★Take AI1 as example, following instruction is step to set analog voltage speed.

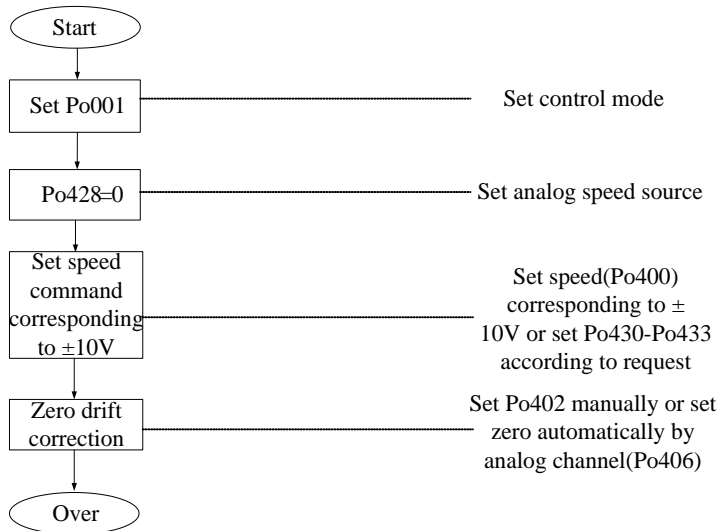

b)Related parameter

Parameter		Remarks
Po001	d □ 3	Control mode selection: analog speed mode

(1) Analog speed mode setting

Po428	Analog speed mode setting Speed Torque			
	Setting range	Setting unit	Mfr's value	When enabled
	0~1	N/A	0	Effective Immediately

Setting value	Content
0	Analog command is set by AI1.

1	Analog command is set by AI2
---	------------------------------

(2) Setting relation between analog and speed

Po400	Max speed corresponding to analog voltage Speed			
	Setting range	Setting unit	Mfr's value	When enabled
	1~10000	r/min	—	Effective Immediately
<p>Set the speed value when analog voltage is 10V. The slope equals to the ratio of 10V/setting value of Po400. Please refer to the right figure about the mfr's setting:</p>				

Attention : Mfr's value of Po400 is related with servomotor, default mfr's value is rated rotation of matching motor.

(3) Analog speed command zero drift compensation

Po402	AI1 command zero drift compensation Speed Torque Position			
	Setting range	Setting unit	Mfr's value	When enabled
	0~±5000	1mv	0	Effective Immediately
<p>AI1command zero drift compensation is to eliminate analog speed command zero drift. The setting method is as following: (1) Short-connect AI1 to AGND. (2) At the mode of analog speed, adjust Po402 to make Lo-27 to 0. Please refer to right figure:</p>				

Po406	AI automatic zero set Speed Torque			
	Setting range	Setting unit	Mfr's value	When enabled
	0~1	N/A	0	Effective Immediately

When AI automatic zero set function is used, please make sure analog input is 0V. If zero drift is too big, servo drive will trip into AL-21.

When using auto zero set function, make sure analog input is 0V, and set Po406 to 1, after about 3s, zero drift

will auto compensate.						
Po426	AI zero drift alarm			Speed	Torque	Position
	Setting range	Setting unit	Mfr's value	When enabled		
	100~5000	mv	2000	Effective Immediately		

(4) Analog speed command of rotation upper and lower limit setting

The function is to set external input analog at analog speed mode. Users can set a pair of volage in the range of -10V~+10V by parameters Po433, Po431 as upper and lower limit of the analog input voltage.After analog input is determined,analog speed can be set via parameter Po432, Po430, lower bound corresponds to the voltage on the analog control speed.

<p>Analog upper and lower limit setting value is related to the accuracy of the analog voltage control,the wider the range of upper and lower limits is,the higher the voltage accuracy is. Do not set the range of upper and lower limit values too small in order to avoid influence on effect of analog adjustment. Specific relationship is shown in the figure on the right:</p>	
---	--

Po430	Corresponding speed of lower limit voltage			Speed	Torque	Position
	Setting range	Setting unit	Mfr's value	When enabled		
	-1000~1000	0.1%	-1000	Effective Immediately		
Po431	Lower limit voltage in speed analog mode			Speed	Torque	Position
	Setting range	Setting unit	Mfr's value	When enabled		
	-1000~1000	0.01V	-1000	Effective Immediately		
Po432	Corresponding speed of upper limit voltage			Speed	Torque	Position
	Setting range	Setting unit	Mfr's value	When enabled		
	-1000~1000	0.1%	1000	Effective Immediately		
Po433	Upper limit voltage in speed analog mode			Speed	Torque	Position
	Setting range	Setting unit	Mfr's value	When enabled		
	-1000~1000	0.01V	1000	Effective Immediately		

Note: in analog speed mode, the motor speed calculation formula is as below:

Corresponding speed of lower limit voltage=value of Po400 X value of Po430

Corresponding speed of upper limit voltage=value of Po400 X value of Po432

(5)Analog command filter

Po404	Analog speed command filter time constant Speed Torque Position			
	Setting range	Setting unit	Mfr's value	When enabled
	1~30000	0.01ms	200	Effective Immediately

This smoothens the speed command by applying a 1st-order filter to the analog speed command input. A value that is too large, however, will slow down response.

(6) Analog terminal control

At the mode of analog speed, and when Po427=1, speed is set by analog, motor start/stop is controlled by terminal. Servo drive will stop at deceleration time by pressing start/stop button or not at the same time. When forward running command is received, servo motor will run to analog speed at the acceleration time, when reverse running command is received, servo motor will run to 0 first then runs reverse to analog speed at the deceleration time.

Po427	Analog terminal control Speed Torque Position			
	Setting range	Setting unit	Mfr's value	When enabled
	0~1	N/A	0	Effective Immediately

c)Input signal setting

Signal name	Terminal	Remarks
AS1	CN3-23	Analog speed command input
AGND	CN3-24	
Input voltage range is from -10Vto10V.		

6.2.2 Soft start

The soft start function converts the stepwise speed reference inside the servodrive to a consistent rate of acceleration and deceleration.

(1)Setting parameters

Po109	Acceleration time speed			
	Setting range	Setting unit	Mfr's value	When enabled
	1~30000	ms	200	Effective Immediately

Po110	Deceleration time speed			
	Setting range	Setting unit	Mfr's value	When enabled
	1~30000	ms	200	Effective Immediately

(2)Instructions of acceleration/deceleration time

The acceleration/deceleration time means the time that speed increases from 0 to rated rotation speed or decreases

from rated speed to 0. Please refer to Fig 6-2-5.

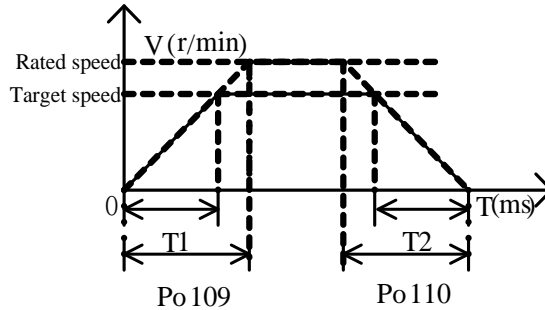

Fig 6-2-5 Soft start function

T1 and T2 are actual acceleration/deceleration time, the unit is ms.

Actual acceleration time $T1 = Po109 \times \text{target speed} / \text{rated speed}$

Actual deceleration time $T2 = Po110 \times \text{target speed} / \text{rated speed}$

6.2.3 S curve smoothness function

During the process of acceleration/deceleration, the rotation speed is unsteady. So add S curve acceleration/deceleration command into speed command to make rotation speed of motor more smooth.

(1) Setting parameters

Po111	S curve acceleration/deceleration time speed			
	Setting range	Setting unit	Mfr's value	When enabled
	0~15000	ms	100	Effective Immediately

Po112	S curve starting indication speed			
	Setting range	Setting unit	Mfr's value	When enabled
	0: Invalid 1: Valid	N/A	0	Effective Immediately

(2) Instruction of S curve smoothness function

Please refer to following figure about S curve function, and T1 and T2 are actual acceleration/deceleration time.

(Please refer to soft start function)

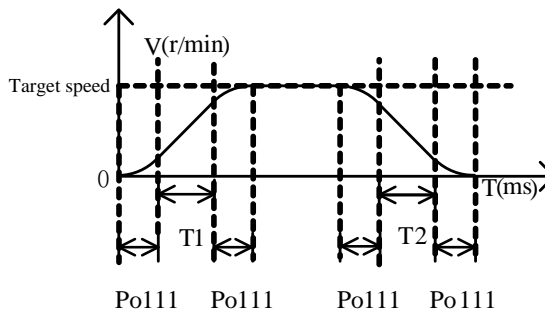

Fig 6-2-6 S curve smoothness function

6.2.4 Zero clamp function

When the zero clamp signal (ZCLAMP) is ON, servo enters into the locking status as soon as the absolute value of command speed drops below the motor speed level in the zero clamp level. The servo motor ignores the speed command and quickly stops and locks the servo motor.

(1) Input signal

Signal name	Default terminal	Remarks
ZCLAMP	CN3-13	Servo motor enters into the locking status when the absolute value of command speed drops below the setting value in the zero clamp level.

(2) Setting parameters

Po127	Zero clamp enabled Speed			
	Setting range	Setting unit	Mfr's value	When enabled
	0: Zero clamp function OFF 1: Zero clamp function ON	N/A	0	Effective Immediately
Po126	Speed value in the zero clamp Speed			
	Setting range	Setting unit	Mfr's value	When enabled
	0 ~30000	0.1r/min	50	Effective Immediately

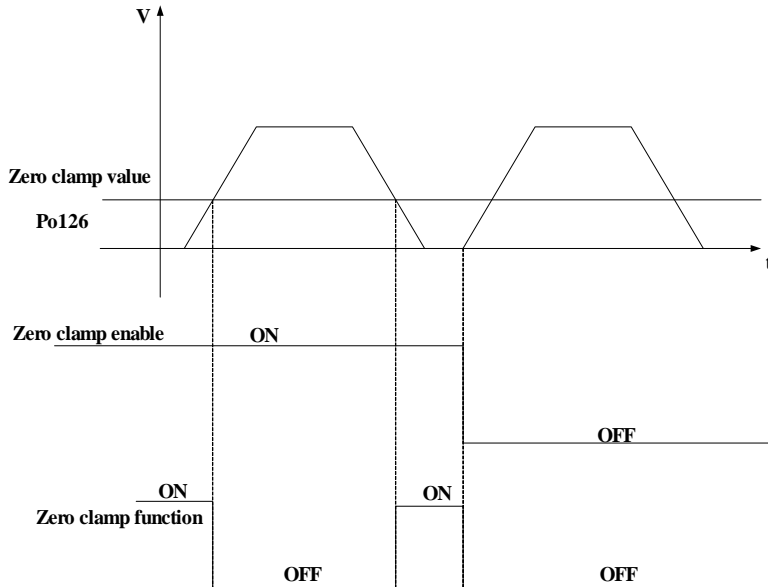

6.2.5 Speed output signal

1) Speed arrival signal output

When the absolute difference between actual rotation speed and command speed is lower than range of target speed (Po117), speed arrival signal is output. This function is not limited by motor rotation direction.

(1) Output signal

Signal name	Default terminals	Remarks
V-CMP	V-CMP+ V-CMP-	Motor rotation speed is close to command speed.

(2) Parameters setting

Po117	Range of target speed			Speed
	Setting range	Setting unit	Mfr's value	When enabled
	0 ~ 30000	0.1r/min	300	Effective Immediately

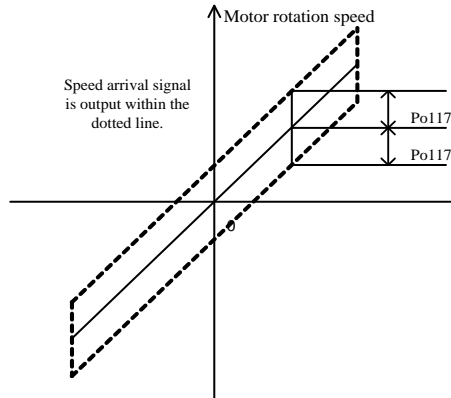

Fig 6-2-8 Speed arrival signal output

Note: solid line represents given speed, speed arrival signal is output within the dotted line.

2) Rotation detection signal output

This signal is output to indicate that the servo motor is currently operating above the setting in parameter Po118.

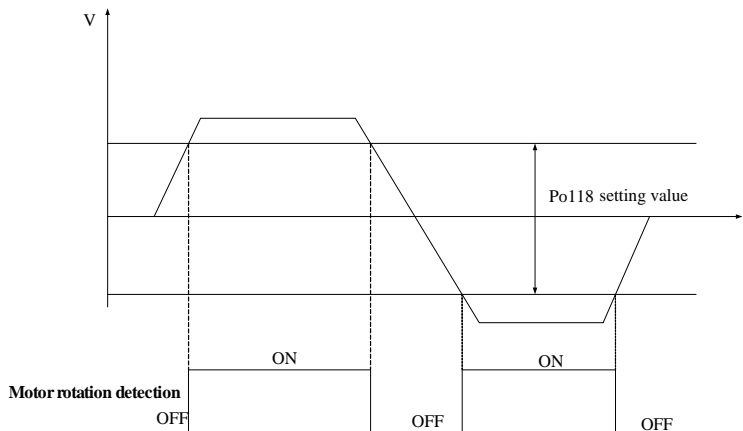

Fig 6-2-9 Rotation detection signal output

(1) Setting output signal

Signal name	Default terminal	Remarks
TGON	TGON+ TGON-	When the absolute value of speed is higher than the value of Po118, TGON signal is output.

(2) Parameters setting

Po118	Rotation detection value Speed			
	Setting range	Setting unit	Mfr's value	When enabled
	0 ~30000	0.1r/min	300	Effective Immediately

3) Analog monitor output

(1) Output signal

Signal name	Code	Terminal	Remarks
Analog monitor output	AO1	CN3-1	Analog monitor output
Analog monitor output	AO2	CN3-14	
Grounding of analog power supply	AGND	CN3-24	

(2) Setting analog monitor signal

So-19	Analog monitor channel 1 speed position torque			
	Setting range	Setting unit	Mfr's value	When enabled
	0~3	N/A	0	Effective Immediately
So-61	Analog monitor channel 2 speed position torque			
	Setting range	Setting unit	Mfr's value	When enabled
	0~3	N/A	0	Effective Immediately

Parameter setting	Output analog contents	Remarks
So-19=0	Servo drive output current	Servodrive output current corresponding to 10V is controlled by So-20.
So-19=1	Servo drive bus voltage	Servodrive max bus line voltage corresponding to 10V is controlled by So-21.
So-19=2	Servo motor rotation speed	Servo motor rotation speed corresponding to 10V is controlled by So-22.
So-19=3	Output voltage 0V + offset	Offset voltage is determined by So-24.
So-61=0	Servo drive output current	Servodrive output current corresponding to 10V is controlled by So-20.
So-61=1	Servo drive bus voltage	Servodrive max bus line voltage corresponding to 10V is controlled by So-21.
So-61=2	Servo motor speed	Servo motor rotation speed corresponding to 10V is controlled by So-22.
So-61=3	Output voltage 0V + offset	Offset voltage is determined by So-62.

(3) Related parameter

So-20	Servodrive output current corresponding to 10V speed position torque			
	Setting range	Setting unit	Mfr's value	When enabled
	1~1000	0.1A	200	Effective Immediately

So-21	Servodrive max bus line voltage corresponding to 10V speed position torque			
	Setting range	Setting unit	Mfr's value	When enabled
	1~500	1V	500	Effective Immediately

So-22	Max rotation speed corresponding to 10V speed position torque			
	Setting range	Setting unit	Mfr's value	When enabled
	1~32000	0.1r/min	30000	Effective Immediately

(4) Analog monitor voltage compensation

Actual analog voltage is compensated by So-24 and So-62.

So-24	Analog monitor voltage compensation 1 speed position torque			
	Setting range	Setting unit	Mfr's value	When enabled
	-10000~+1000	mv	0	Effective Immediately
So-62	Analog monitor voltage compensation 2 speed position torque			
	Setting range	Setting unit	Mfr's value	When enabled
	-10000~+10000	mv	0	Effective Immediately

Analog monitor voltage compensation updates in real time, users can confirm and adjust the signal at the same time. After adjustment is finished, please press SET key for 0.5s, save it and quit.

Note: So-24 or So-62 plus analog input voltage equals analog output AO.

6.3 Torque mode

Torque mode includes analog torque mode and internal register torque mode, user can select it by Po001. The diagram is as below:

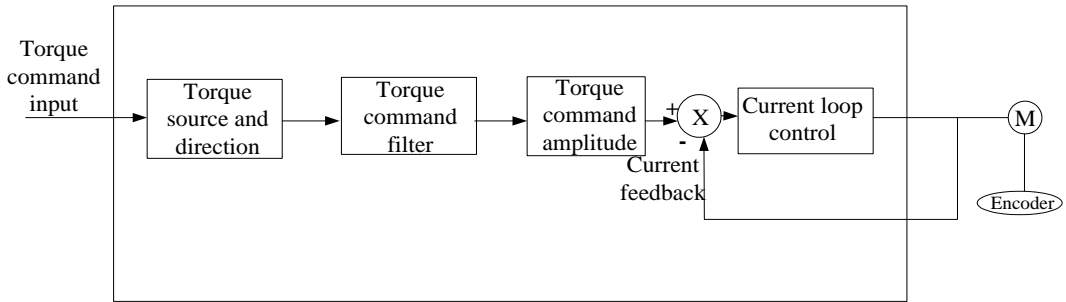

Fig 6.3.1 Torque control diagram

6.3.1 Parameters setting

Parameters		Remarks
Po001	d □ 2	Control mode selection: internal register torque mode.
	d □ 4	Control mode selection: analog torque mode.



- ★ Connect power supply of servo main circuit, power supply of control circuit, motor power cable and encoder cable correctly.
- ★ Jog trial operation by keypad.
- ★ Refer to Fig 6.3.2 and Fig 6.3.3 to connect DI/DO.
- ★ Set the related parameters of torque mode.
- ★ Operating servo drive and make sure the running direction of servo motor is correct, and set related parameters of gain adjustment, please refer to Chapter 7.3.

1) Internal register torque mode

a) Wiring diagram

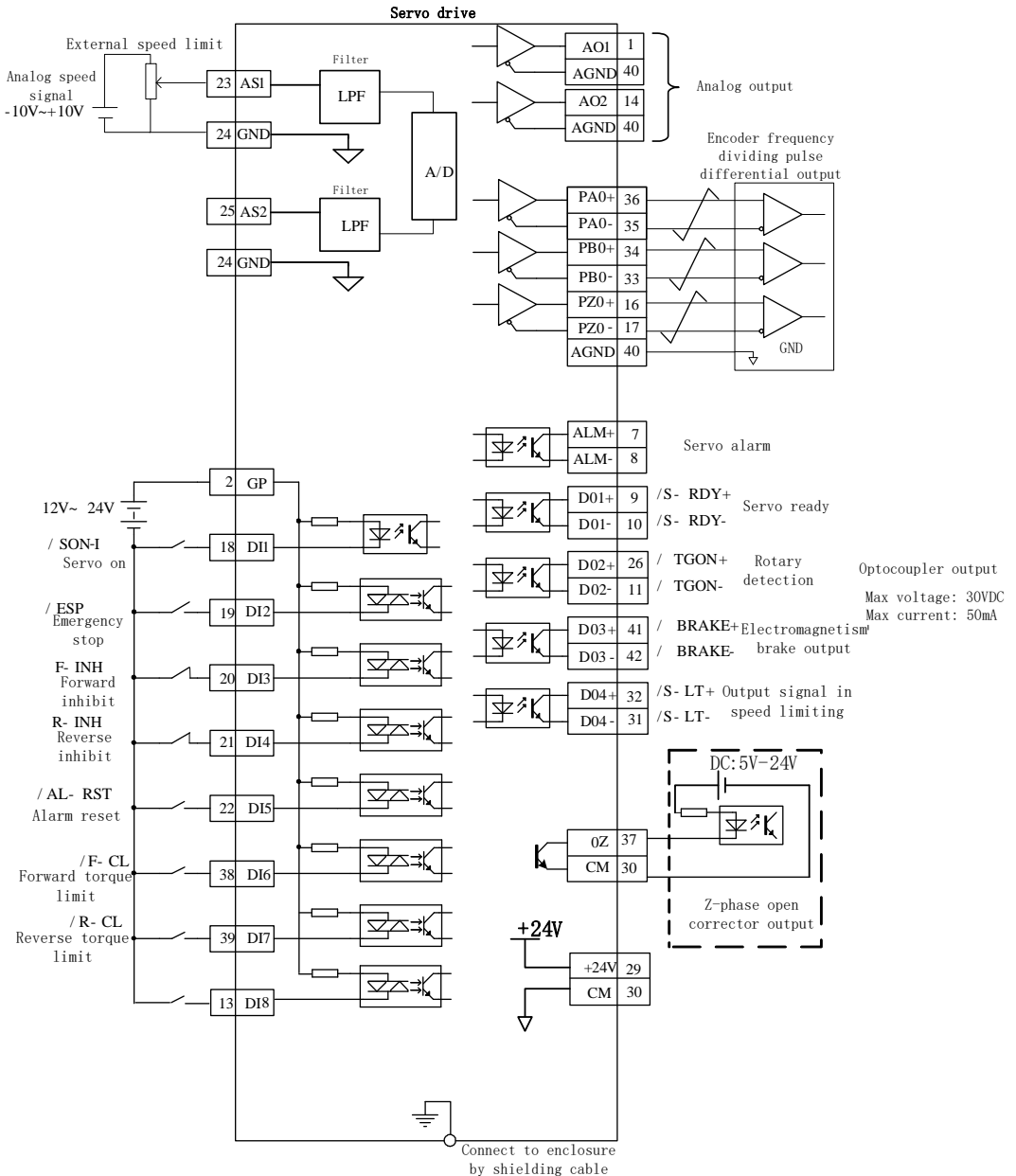



Fig 6.3.2 Diagram of internal register torque mode

Note:

1  represents twisted-pair wires.

2 Servodrive has internal 24 VDC power supply. But external 12~24VDC power supply is recommended.

3 DI1~DI8 are programmable input terminals, and DO1~DO4 are programmable output terminals. Users can redefine these terminals by parameter.

b) Related parameters

Parameter		Remarks		
Po001	d □ 2	Control mode selection: internal register torque mode		
Po204	Internal given torque		<u>Internal register torque</u>	
	Setting range	Setting unit	Mfr's value	When enabled
	-800~800	1% of rated torque	10	Effective Immediately

 Note: once internal register torque mode is enabled, servo drive will start running Immediate. Please be careful!

2) Analog torque mode

a) Wiring diagram

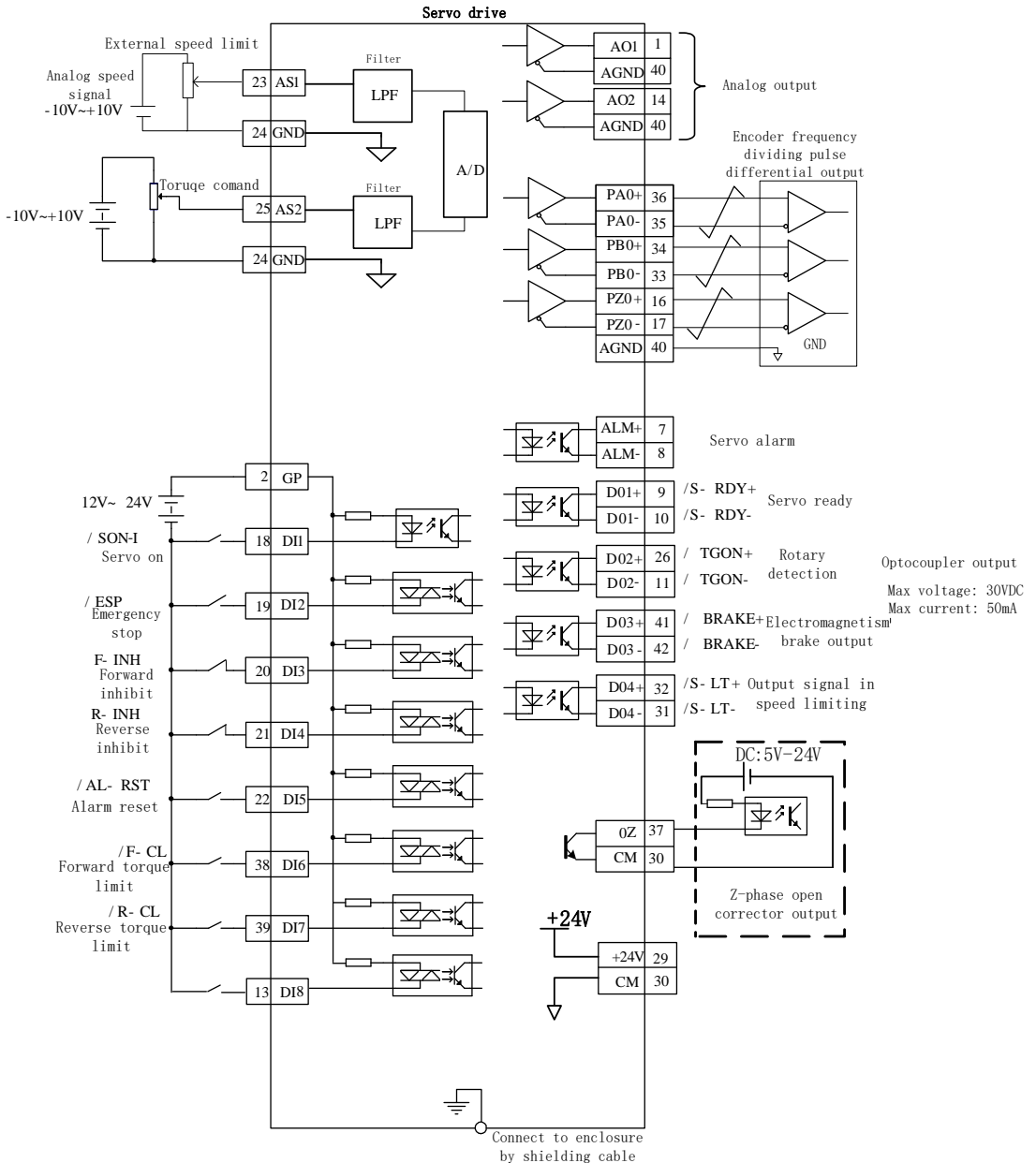



Fig 6.3.3 Diagram of analog torque mode

Note:

1  represents twisted-pair wires.

2 Servo drive has internal 24 VDC power supply. But external 12~24VDC power supply is recommended.

3 DI1~DI8 are programmable input terminals, and DO1~DO4 are programmable output terminals. Users can redefine these terminals by parameter.

b) Related parameters

Parameter		Remarks
Po001	d □ 4	Control mode selection: analog torque mode.

(1) Analog torque command source

Po429	Analog torque command source			Speed Torque Position
	Setting range	Setting unit	Mfr's value	When enabled
	0~1	N/A	1	Effective Immediately

Setting value	Constent
0	Analog command is set by AI1.
1	Analog command is set by AI2.

(2) Relationship between analog and torque

Po401	Max torque corresponding to Analog torque			Torque
	Setting range	Setting unit	Mfr's value	When enabled
	1~800	1% of rated torque	100	Effective Immediately

Set the torque value when analog voltage is 10V.
 The slope equals to the ratio of 10V/setting value of Po401.
 Please refer to the right figure about the mfr's setting:

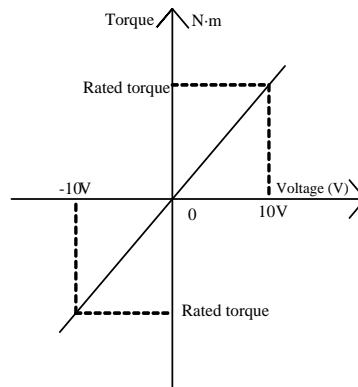

(3) AI2 channel zero drift compensation

Po403	AI2 torque command zero drift compensation			Speed Torque Position
	Setting range	Setting unit	Mfr's value	When enabled

	0~±5000	1mv	0	Effective Immediately
<p>Analog torque command zero drift compensation is to eliminate analog torque command zero drift.</p> <p>The setting method is as following:</p> <p>(1) Short-connect AI2 to AGND.</p> <p>(2) At the mode of analog torque, adjust Po403 to make Lo-28 to 0.</p> <p>Please refer to right figure:</p>				

Po406	AI automatic zero set Speed Torque			
	Setting range	Setting unit	Mfr's value	When enabled
	0~1	N/A	0	Effective Immediately

When AI automatic zero set function is used, please make sure analog input is 0V. If zero drift is too big, servo drive will trip into AL-21.

When using auto zero set function, make sure analog input is 0V, and set Po406 to 1, after about 3s, zero drift will auto compensate.

(4) Analog torque command filter

Po405	Analog torque command filter time constant Torque			
	Setting range	Setting unit	Mfr's value	When enabled
	1~30000	0.01ms	200	Effective Immediately

This smoothens the speed command by applying a 1st-order filter to the analog speed command input. A value that is too large, however, will slow down response.

(5) Upper and lower limit setting of analog torque

The upper and lower limit setting of analog torque is the same with the setting method of analog speed mode, the setting parameters are different.

Po434	Torque corresponding to lower limit voltage in torque analog mode Speed Torque Position			
	Setting range	Setting unit	Mfr's value	When enabled
	-1000~1000	0.1%	-1000	Effective Immediately
Po435	Lower limit voltage in torque analog mode Speed Torque Position			
	Setting range	Setting unit	Mfr's value	When enabled
	-1000~1000	0.01V	-1000	Effective Immediately
Po436	Torque corresponding to upper limit voltage in torque analog mode Speed Torque Position			
	Setting range	Setting unit	Mfr's value	When enabled

	-1000~1000	0.1%	1000	Effective Immediately
Po437	Upper limit voltage in torque analog mode			Speed Torque Position
	Setting range	Setting unit	Mfr's value	When enabled
	-1000~1000	0.01V	1000	Effective Immediately

Note: in analog torque mode, the formula of motor torque is:

Torque corresponding to lower limit voltage=Po401 value× Po434 value

Torque corresponding to upper limit voltage=Po401 value× Po436 value\

c) Input signal

Signal name	Name	Terminals	Remarks
Analog torque command input	AS2	CN3-25	Analog torque command input
Grounding for analog	AGND	CN3-24	
Range of input voltage: -10V~ +10V			

6.3.2 Soft start

This function is used to converter step torque command to constant acceleration slope mode at torque mode.

1) Parameters setting

Po212	Torque increasing time			Torque
	Setting range	Setting unit	Mfr's value	When enabled
	0~30000	0.1ms	0	Effective Immediately

Po213	Torque decreasing time			Torque
	Setting range	Setting unit	Mfr's value	When enabled
	0~30000	0.1ms	0	Effective Immediately

2) Instructions of increasing/decreasing time

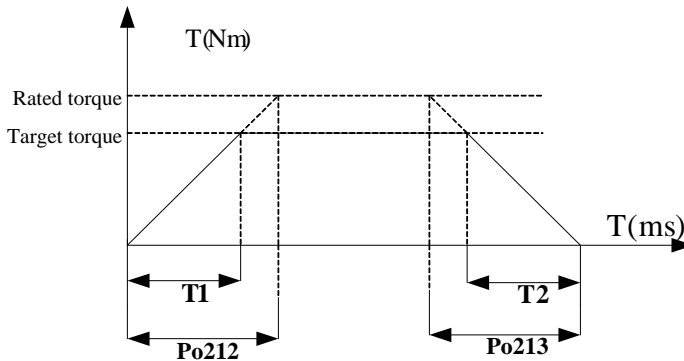

T1 and T2 are actual torque increasing and decreasing time, the unit is ms.

Actual increasing time $T1 = Po212 \times \text{target torque} / \text{rated torque}$

Actual decreasing time $T_2 = Po213 \times \text{target torque} / \text{rated torque}$

6.3.3 Speed limiting at torque mode

This function serves to limit the servo motor speed during torque control to protect the machine.

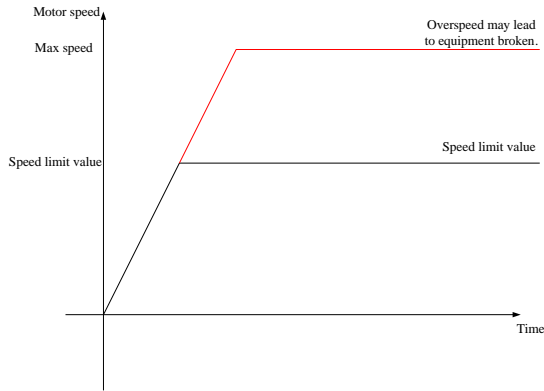

In torque mode, speed limit includes:

1. Internal speed limit
 2. Analog speed limit
 3. Speed limited by max rotation speed and actual motor max speed.
- The third limit method is constantly enabled, and the rest of methods are limited by some conditions.

(1) Speed limit during torque control

Po210	Speed Limit During Torque Control Torque			
	Setting range	Setting unit	Mfr's value	When enabled
	0~2	N/A	2	Effective Immediately

Parameter	Remarks
Po210=0	Use the value set in Po211 as the speed limit.
Po210=1	Inputs an analog voltage command as the servo motor speed limit value, this is valid for forward/reverse rotation.
Po210=2	Use the lower value between max rotation speed Po002 and actual motor max rotation speed as the speed limit.

(2) Related parameter

Po211	Internal speed limit Torque			
	Setting range	Setting unit	Mfr's value	When enabled
	0~32000	0.1r/min	20000	Effective Immediately

6.3.4 Limiting Torque

The servodrive provides the following three methods for limiting output torque to protect the machine.

1. Internal max torque limit
2. Torque limiting by internal register controlled by terminals
3. Torque limiting by analog.

Internal max torque limit is constantly enabled, and the rest of methods are limited by some conditions. When three methods are all valid, the actual torque limit value is the smallest value of them.

(1) Internal max torque limit

Po202	Inernal max torque limit value speed position torque			
	Setting range	Setting unit	Mfr's value	When enabled
	0~800	1% of rated torque	200	Effective Immediately

Note: Too small a torque limit setting will result in insufficient torque.

(2) Torque limiting controlled by terminals

Signal	Abbreviation	Remarks
Forward torque limit	F-CL	To limit servo motor forward torque.
Reverse torque limit	R-CL	To limit servo motor reverse torque.

When using forward torque limit function, a programmable terminal must be set to forward torque limit (F-CL).

When using reverse torque limit function, a programmable terminal must be set to reverse torque limit(R-CL).

Po208	Forward max torque limit speed position torque			
	Setting range	Setting unit	Mfr's value	When enabled
	0~800	1% of rated torque	100	Effective Immediately

Po209	Reverse max torque limit speed position torque			
	Setting range	Setting unit	Mfr's value	When enabled
	0~800	1% of torque	100	Effective Immediately

When the signal F-CL is valid, forward max torque limit value should be lower than Po208.

When the signal F-CL is valid, reverse max torque limit value should be lower than Po209.

Note: Too small a torque limit setting of Po208 and Po209 will result in insufficient torque.

(3) Torque limiting by analog

Torque limiting by analog is that torque is limited by the input voltage of analog torque terminal. Please refer to Po401 about the relationship between analog voltage and torque limiting value.

Po203	Torque limiting by analog speed position torque			
	Setting range	Setting unit	Mfr's value	When enabled
	0~1	N/A	0	Effective Immediately

When Po203=0, torque limiting by analog is invalid, when Po203=1, torque limiting by analog is valid.

There is no polarity in the input voltage of the analog voltage for torque limiting. The absolute values of both + and - voltages are input, and a torque limit value corresponding to that absolute value is applied in the forward or reverse direction.

6.3.5 Related output

1) Output signal in torque limiting

When torque is limited, DO terminal will output signal, and it is valid for forward/reverse running.

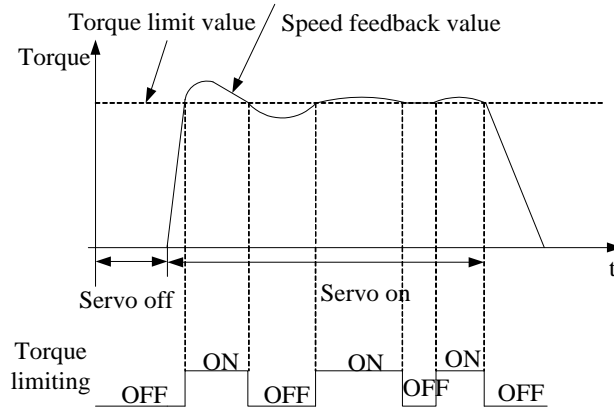

(1) Output signal

Signal	Default terminal	Remarks
T-LT	T-LT+ T-LT-	The signal is output when torque is limited.

(2) Parameters setting

Po237	Target torque range			Torque
	Setting range	Setting unit	Mfr's value	When enabled
	1 ~ 50	1%	2	Effective Immediately
Po238	Torque filter frequency			Torque
	Setting range	Setting unit	Mfr's value	When enabled
	1~ 1000	0.1Hz	10	Effective Immediately

6.4 Position pulse mode

Command unit: distinguishable minimum command, from the command PC/PLC gives to servo drive

Encoder unit: input command, treated by electric gear ratio

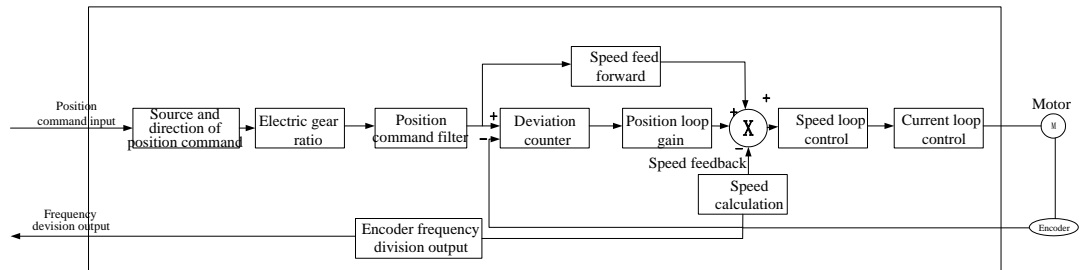

Fig 6.4.1 Position pulse mode block diagram

6.4.1 Parameters setting

Position pulse mode includes internal register position mode and external position mode, user can select it by Po001.

Parameters		Remarks
Po001	d □ 1	Control mode selection: position pulse mode.
	d □ 5	Control mode selection: internal register position mode.



- ★ Connect power supply of servo main circuit, power supply of control circuit, motor power cable and encoder cable correctly.
- ★ Jog trial operation by keypad.
- ★ Refer to Fig 6.4.2 and Fig 6.4.6 to connect DI/DO.
- ★ Set the related parameters of position mode.
- ★ Operating servo drive and make sure the running direction of servo motor is correct, and set related parameters of gain adjustment, please refer to Chapter 7.3.

1) External position pulse mode

a) Wiring diagram

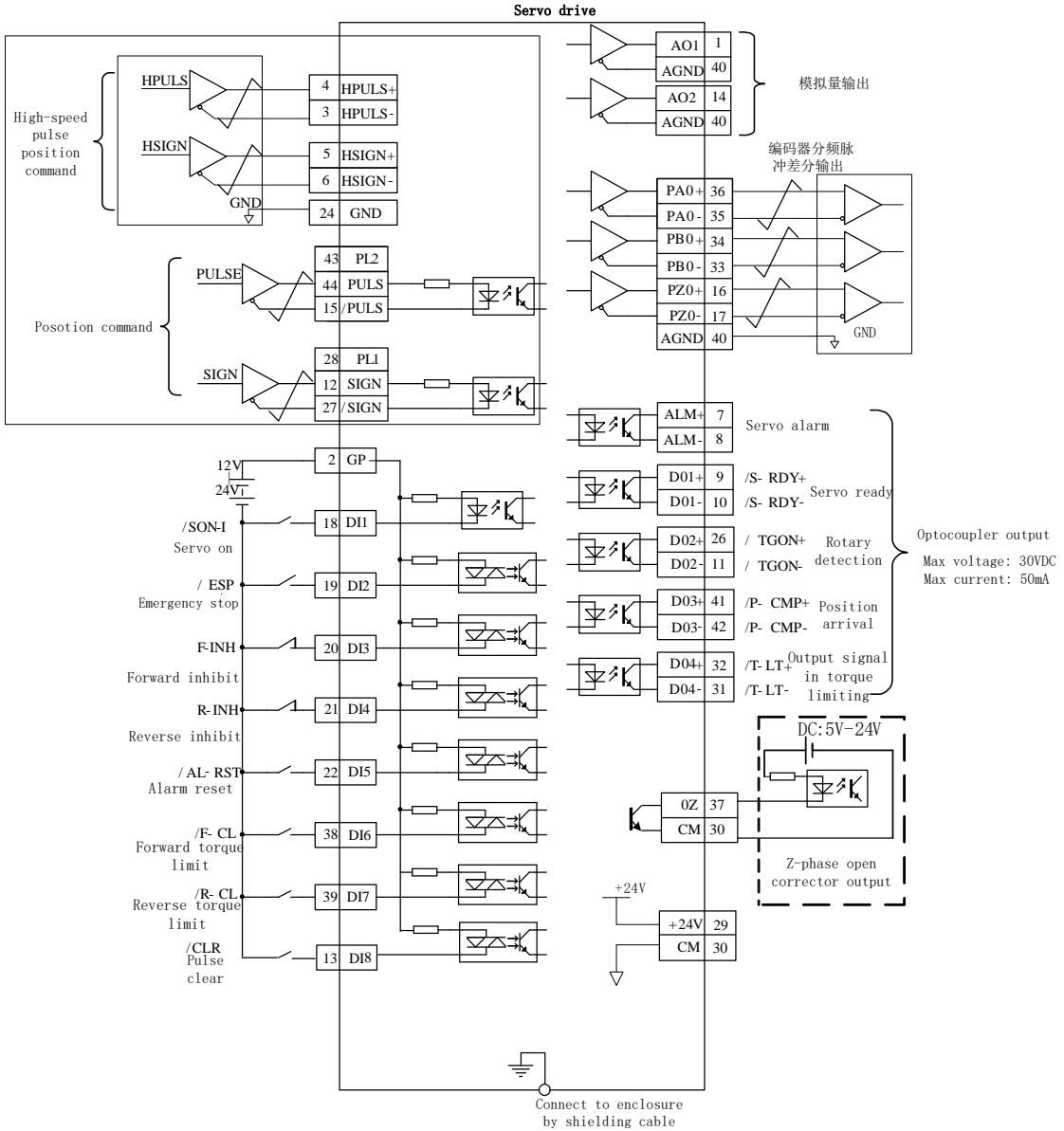



Fig 6.4.2 Wiring diagram of position pulse mode

Note:

- 1  represents twisted-pair wires.
- 2 Servo drive has internal 24 VDC power supply. But external 12~24VDC power supply is recommended.
- 3 DI1~DI8 are programmable input terminals, and DO1~DO4 are programmable output terminals. Users can redefine these terminals by parameter.
- 4 The status of position command is set by the parameter Po300, differential signal is shown in this example. .
- 5 The position command is 5V differential signal, if user adopts other interface, please refer to 4.3.1

b) Related parameters

(1) control mode selection

Parameters		Remarks
Po001	d □ 1	Control mode selection: position pulse command mode.

(2) Input pulse command source

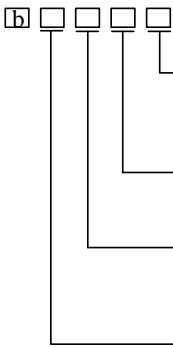
Parameters		Remarks																								
Po374	Four-parameter	 <table border="1" style="margin-left: 20px;"> <tr> <td>A</td> <td>Low-speed pulse source</td> </tr> <tr> <td>0</td> <td>off</td> </tr> <tr> <td>1</td> <td>on</td> </tr> </table> <table border="1" style="margin-left: 20px;"> <tr> <td>B</td> <td>High-speed pulse source</td> </tr> <tr> <td>0</td> <td>off</td> </tr> <tr> <td>1</td> <td>on</td> </tr> </table> <table border="1" style="margin-left: 20px;"> <tr> <td>C</td> <td>Internal position pulse source</td> </tr> <tr> <td>0</td> <td>off</td> </tr> <tr> <td>1</td> <td>on</td> </tr> </table> <table border="1" style="margin-left: 20px;"> <tr> <td>D</td> <td>Pulse source of electronic cam</td> </tr> <tr> <td>0</td> <td>off</td> </tr> <tr> <td>1</td> <td>on</td> </tr> </table>	A	Low-speed pulse source	0	off	1	on	B	High-speed pulse source	0	off	1	on	C	Internal position pulse source	0	off	1	on	D	Pulse source of electronic cam	0	off	1	on
A	Low-speed pulse source																									
0	off																									
1	on																									
B	High-speed pulse source																									
0	off																									
1	on																									
C	Internal position pulse source																									
0	off																									
1	on																									
D	Pulse source of electronic cam																									
0	off																									
1	on																									

Note: when setting Po374, user can set 1 to needed pulse source. If Po374.A=1, Po374.C=1, actual pulse command=low speed pulse command + internal position pulse command.

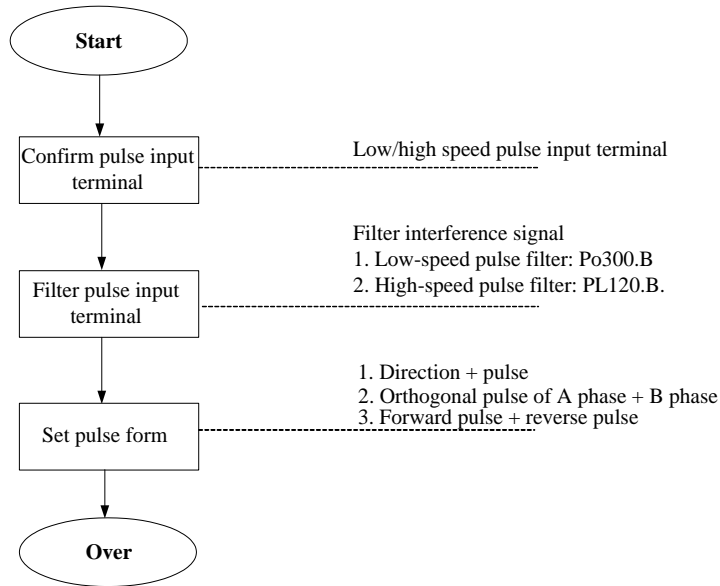

① Pulse command input terminal

Servo drive has 2 groups of pulse command input terminals.

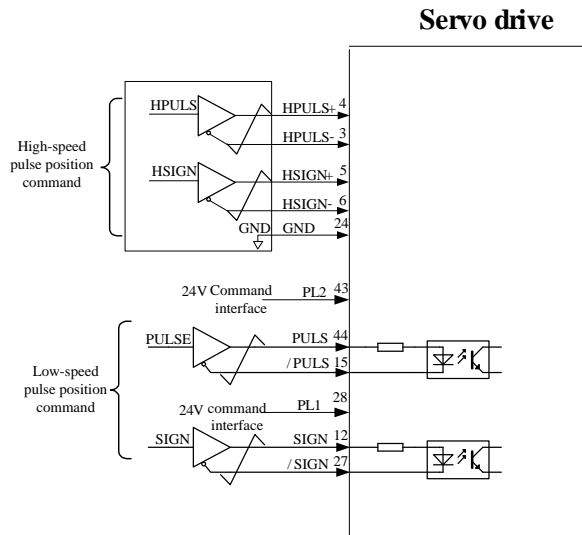

- Low-speed pulse input terminals (PL2, PULS+, PL1, SIGN+, SIGN-) can accept differential input signal (input pulse max frequency is 500Khz) and open collector input signal(input pulse max frequency is 200Khz).
- High-speed pulse input terminals (HPULS+, HPULS-,HSIGN+,HSIGN-) can accept 5V differential input signal(input pulse max frequency is 4Mhz).

② Pulse input pin filter

For low-speed pulse or high-speed pulse input terminal, filter time need to be set to filter input pulse command, in order to prevent interference signal.

Parameter	Remarks	
Po300	b □□0□	Pulse input filter frequency is 4MHz
	b □□1□	Pulse input filter frequency is 2MHz
	b □□2□	Pulse input filter frequency is 1MHz
	b □□3□	Pulse input filter frequency is 500KHz
	b □□4□	Pulse input filter frequency is 200KHz
	b □□5□	Pulse input filter frequency is 150KHz
	b □□6□	Pulse input filter frequency is 80kHz

PL120	High-speed pulse control			speed	position	torque																																																							
	Setting range	Setting unit	Mfr's value	When enabled																																																									
	Four-parameter	N/A	0000	Effective Immediately																																																									
	<table border="1"> <tr> <td>A</td> <td>High - speed pulse type</td> </tr> <tr> <td>0</td> <td>Direction+ Pulse</td> </tr> <tr> <td>1</td> <td>Dipulse</td> </tr> <tr> <td>2</td> <td>Orthogonal pulse</td> </tr> <tr> <td>B</td> <td>High-speed pulse filtering</td> </tr> <tr> <td>0</td> <td>8MHz</td> </tr> <tr> <td>1</td> <td>4MHz</td> </tr> <tr> <td>2</td> <td>2MHz</td> </tr> <tr> <td>3</td> <td>1MHz</td> </tr> <tr> <td>4</td> <td>500KHz</td> </tr> <tr> <td>5</td> <td>200KHz</td> </tr> <tr> <td>6</td> <td>150KHz</td> </tr> <tr> <td>C</td> <td>High-speed pulse direction</td> </tr> <tr> <td>0</td> <td>HPULS anti-logic, HSIGN anti-logic</td> </tr> <tr> <td>1</td> <td>HPULS positive logic, HSIGN positive logic</td> </tr> <tr> <td>2</td> <td>HPULS anti-logic, HSIGN positive logic</td> </tr> <tr> <td>3</td> <td>HPULS positive logic, HSIGN anti- logic</td> </tr> <tr> <td>4</td> <td>Exchange HPULS and HSIGN</td> </tr> <tr> <td>D</td> <td>DI7/DI8 filter time</td> </tr> <tr> <td>0</td> <td>800KHz</td> </tr> <tr> <td>1</td> <td>400KHz</td> </tr> <tr> <td>2</td> <td>200KHz</td> </tr> <tr> <td>3</td> <td>100KHz</td> </tr> <tr> <td>4</td> <td>40KHz</td> </tr> <tr> <td>5</td> <td>30KHz</td> </tr> <tr> <td>6</td> <td>16KHz</td> </tr> <tr> <td>7</td> <td>8 KHz</td> </tr> <tr> <td>8</td> <td>4 KHz</td> </tr> </table>						A	High - speed pulse type	0	Direction+ Pulse	1	Dipulse	2	Orthogonal pulse	B	High-speed pulse filtering	0	8MHz	1	4MHz	2	2MHz	3	1MHz	4	500KHz	5	200KHz	6	150KHz	C	High-speed pulse direction	0	HPULS anti-logic, HSIGN anti-logic	1	HPULS positive logic, HSIGN positive logic	2	HPULS anti-logic, HSIGN positive logic	3	HPULS positive logic, HSIGN anti- logic	4	Exchange HPULS and HSIGN	D	DI7/DI8 filter time	0	800KHz	1	400KHz	2	200KHz	3	100KHz	4	40KHz	5	30KHz	6	16KHz	7	8 KHz	8
A	High - speed pulse type																																																												
0	Direction+ Pulse																																																												
1	Dipulse																																																												
2	Orthogonal pulse																																																												
B	High-speed pulse filtering																																																												
0	8MHz																																																												
1	4MHz																																																												
2	2MHz																																																												
3	1MHz																																																												
4	500KHz																																																												
5	200KHz																																																												
6	150KHz																																																												
C	High-speed pulse direction																																																												
0	HPULS anti-logic, HSIGN anti-logic																																																												
1	HPULS positive logic, HSIGN positive logic																																																												
2	HPULS anti-logic, HSIGN positive logic																																																												
3	HPULS positive logic, HSIGN anti- logic																																																												
4	Exchange HPULS and HSIGN																																																												
D	DI7/DI8 filter time																																																												
0	800KHz																																																												
1	400KHz																																																												
2	200KHz																																																												
3	100KHz																																																												
4	40KHz																																																												
5	30KHz																																																												
6	16KHz																																																												
7	8 KHz																																																												
8	4 KHz																																																												

Pulse command filter frequency is 100K, and the time is 0.01ms. If there is clutter which time is shorter than

0.005ms, then clutter will be eliminated.

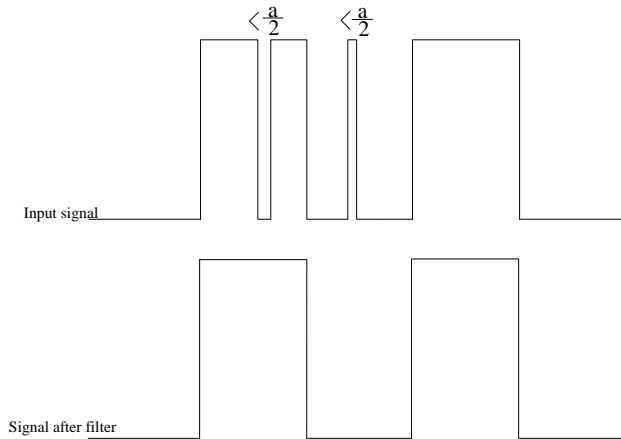

When pulse filter time is set to a , and there are clutter which time is shorter than $a/2$, then clutter will be eliminate.

③ Pulse command form

Pulse command has 3 kinds of forms: direction+pulse, A phase+B phase orthogonal pulse, and forward pulse/reverse pulse.

Take the example of positive logic of pulse command.

Parameter		Command pulse form	Forward rotation command	Reverse rotation command	
Po300	b □□□0	Signal +pulse			
	b □□□1	CW pulse+CCW pulse			
	b □□□2	Two-phase pulse train with 90° phase differential (A phase, B phase)			
	Remarks				
	b □0□□	PULS negative logic, SIGN negative logic			
	b □1□□	PULS positive logic, SIGN positive logic			
	b □2□□	PULS negative logic, SIGN positive logic			
	b □3□□	PULS positive logic, SIGN negative logic			
b □4□□	PULS exchanges with SIGN.				

Modifying positive/negative logic will change motor rotation direction, please be carefully before modifying the

value

c) Input terminal

Signal name		Terminal	Remarks
PULS	PULS	CN3-44	Low speed 5V pulse command input.
	/ PULS	CN3-15	
	HPULS+	CN3-4	High speed differential 5V pulse command input.
	HPULS-	CN3-3	
SIGN	SIGN	CN3-12	Low speed 5V pulse direction input.
	/ SIGN	CN3-27	
	HSIGN+	CN3-5	High speed differential 5V direction command input.
	HSIGN-	CN3-6	
PL1	PL1	CN3-28	24V power pulse direction input.
	/ SIGN	CN3-27	
PL2	PL2	CN3-43	24V power pulse command input.
	/ PULS	CN3-15	

2) Internal register position pulse mode

a) Wiring diagram

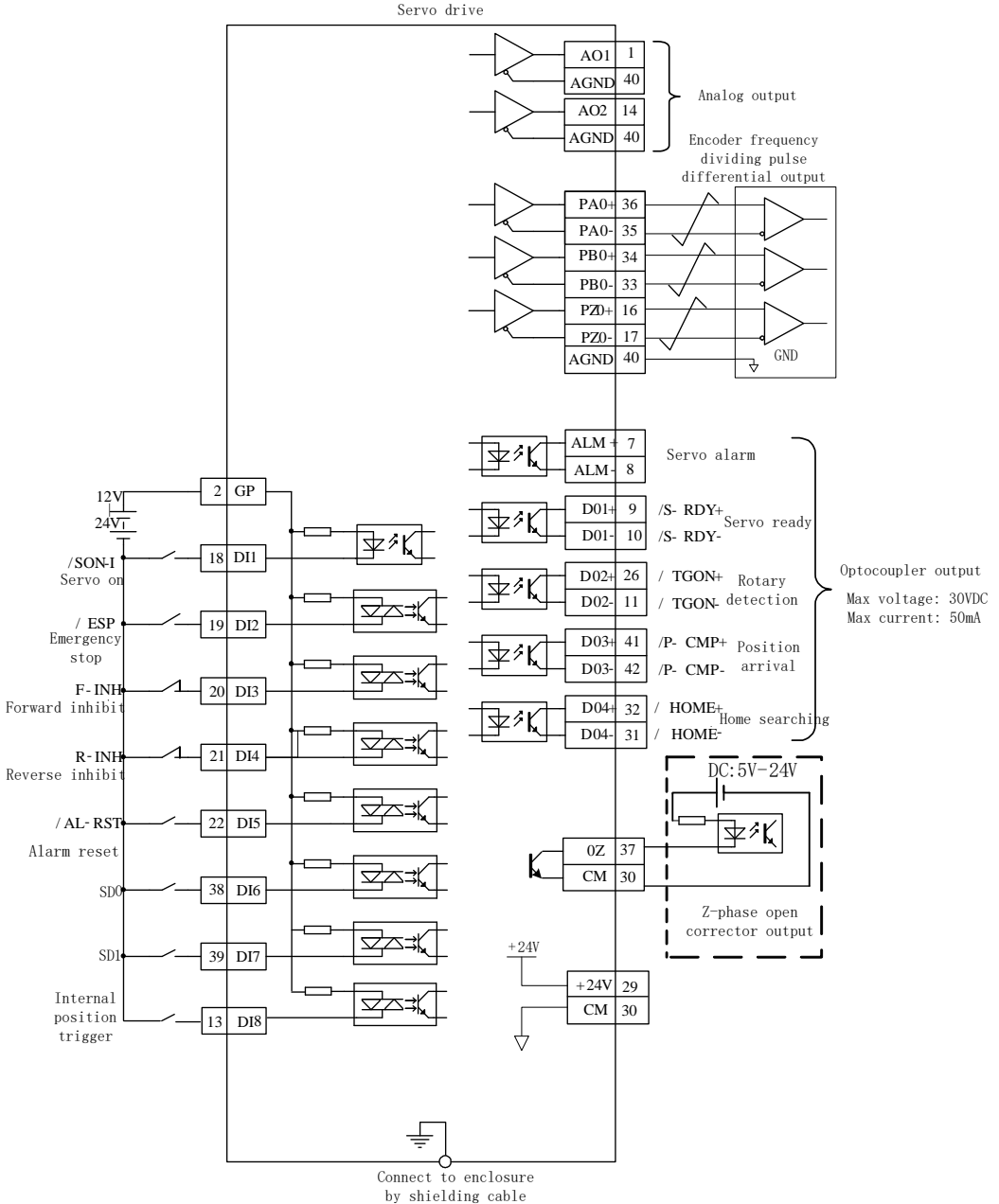

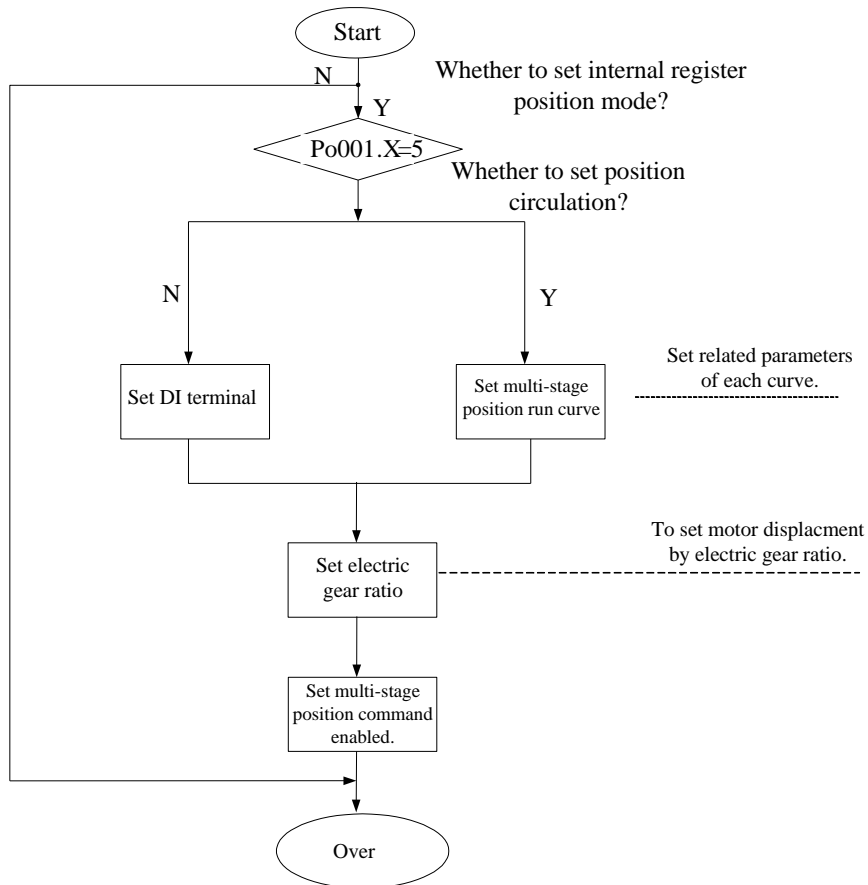

Fig 6.4.6 Wiring of internal position pulse mode

Note:

1.  represents twisted-pair wires.
2. Servo drive has internal 24 VDC power supply. But external 12~24VDC power supply is recommended.
3. DI1~DI8 are programmable input terminals, and DO1~DO4 are programmable output terminals. Users can redefine these terminals by parameter.

At internal position command mode, 8 preset position commands can be set by parameters (Po350-Po364), and can be activated by use of input contacts SD0~SD2. Multistage position means 8-stage position commands are saved in the servo drive, displacement, max running speed and acceleration/deceleration time can be set.



Preset positions are programmable and can be selected according to the table below:

Position command	SD2	SD1	SD0	Position command parameter		Speed parameter
1	0	0	0	Given position of position 1	Po350	Po330
2	0	0	1	Given position of position 2	Po352	Po331

3	0	1	0	Given postion of postion 3	Po354	Po332
4	0	1	1	Given postion of postion 4	Po356	Po333
5	1	0	0	Given postion of postion 5	Po358	Po334
6	1	0	1	Given postion of postion 6	Po360	Po335
7	1	1	0	Given postion of postion 7	Po362	Po336
8	1	1	1	Given postion of postion 8	Po364	Po337

Note: the default status of SD2, SD1 and SD0 is 000, 0 represents terminal open, 1represents terminal closed.

When Po348.X=0, multi-stage position function is invalid. When Po348.X=1, multi-stage position function is valid according to setting position. The interval time between each position is set by Po366-Po373, cycle times is control by Po349. If interval time is 0, then it will switch to next group at max speed, when Po349=0, cycle continues.

b) Related parameters

Parameters		Remarks
Po001	d □ 5	Control mode selection: internal register position mode.

Internal register position mode includes incremental mode and absolute mode.

Parameter	Remarks	
Po341	0	Incremental mode
	1	Absolute mode

Example below shows the difference between absolute and incremental moves.

For two pulse commands of 10 pulses position pulse command and followed with another 20 pulses, the travelled positions will be different.

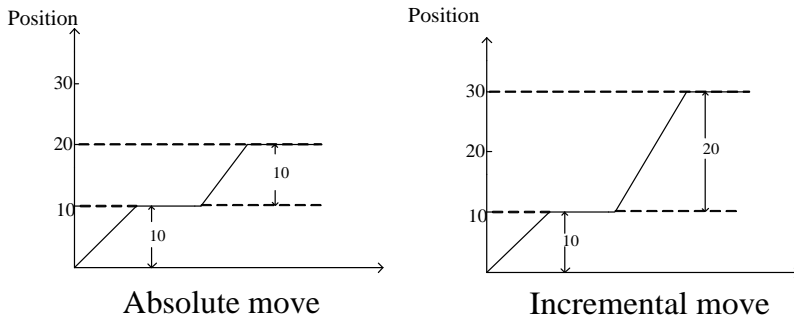

When So-30=1(incremental move), battery protection will be automatically blocked, internal register position absolute move does not adopt encoder feedback absolute value position. When So-30=0 (absolute move), internal register position absolute move will adopt encoder feedback absolute position.

Note: The above function of So-30 is only valid for absolute value type servo drive.

Po348	Setting of multistage internal position			<u>Internal register position</u>													
	Setting range	Setting unit	Mfr's value	When enabled													
	Two-parameter	N/A	2 0	Effective Immediately													
	<table border="1" style="margin-left: 20px;"> <tr> <td>X</td> <td>Multistage position function setting</td> </tr> <tr> <td>0</td> <td>Invalid</td> </tr> <tr> <td>1</td> <td>Valid</td> </tr> </table> <table border="1" style="margin-left: 20px;"> <tr> <td>Y</td> <td>Stage numbers setting</td> </tr> <tr> <td>2</td> <td>2ed position</td> </tr> <tr> <td>3</td> <td>3th position</td> </tr> <tr> <td>...</td> <td>.....</td> </tr> </table>				X	Multistage position function setting	0	Invalid	1	Valid	Y	Stage numbers setting	2	2ed position	3	3th position	...
X	Multistage position function setting																
0	Invalid																
1	Valid																
Y	Stage numbers setting																
2	2ed position																
3	3th position																
...																

Po342	Internal position trigger			<u>Internal register position</u>
	Setting range	Setting unit	Mfr's value	When enabled
	0: no trigger 1: trigger	N/A	0	Effective Immediately
When Po342=1, internal position mode is triggered, after triggering, value of Po342 returns to 0 automatically. It is usually used for communication mode.				

Po310	Acceleration time of internal position 1			<u>Internal register position</u>
	Setting range	Setting unit	Mfr's value	When enabled
	0~32000	ms	100	Effective Immediately
Po311	Deceleration time of internal position 1			<u>Internal register position</u>
	Setting range	Setting unit	Mfr's value	When enabled
	0~32000	ms	100	Effective Immediately
Po312	Acceleration time of internal position 2			<u>Internal register position</u>
	Setting range	Setting unit	Mfr's value	When enabled
	0~32000	ms	100	Effective Immediately
Po313	Deceleration time of internal position 2			<u>Internal register position</u>
	Setting range	Setting unit	Mfr's value	When enabled
	0~32000	ms	100	Effective Immediately
Po314	Acceleration time of internal position 3			<u>Internal register position</u>
	Setting range	Setting unit	Mfr's value	When enabled
	0~32000	ms	100	Effective Immediately

Po315	Deceleration time of internal position 3			<u>Internal register position</u>
	Setting range	Setting unit	Mfr's value	When enabled
	0~32000	ms	100	Effective Immediately
Po316	Acceleration time of internal position 4			<u>Internal register position</u>
	Setting range	Setting unit	Mfr's value	When enabled
	0~32000	ms	100	Effective Immediately
Po317	Deceleration time of internal position 4			<u>Internal register position</u>
	Setting range	Setting unit	Mfr's value	When enabled
	0~32000	ms	100	Effective Immediately
Po318	Acceleration time of internal position 5			<u>Internal register position</u>
	Setting range	Setting unit	Mfr's value	When enabled
	0~32000	ms	100	Effective Immediately
Po319	Deceleration time of internal position 5			<u>Internal register position</u>
	Setting range	Setting unit	Mfr's value	When enabled
	0~32000	ms	100	Effective Immediately
Po320	Acceleration time of internal position 6			<u>Internal register position</u>
	Setting range	Setting unit	Mfr's value	When enabled
	0~32000	ms	100	Effective Immediately
Po321	Deceleration time of internal position 6			<u>Internal register position</u>
	Setting range	Setting unit	Mfr's value	When enabled
	0~32000	ms	100	Effective Immediately
Po322	Acceleration time of internal position 7			<u>Internal register position</u>
	Setting range	Setting unit	Mfr's value	When enabled
	0~32000	ms	100	Effective Immediately
Po323	Deceleration time of internal position 7			<u>Internal register position</u>
	Setting range	Setting unit	Mfr's value	When enabled
	0~32000	ms	100	Effective Immediately
Po324	Acceleration time of internal position 8			<u>Internal register position</u>
	Setting range	Setting unit	Mfr's value	When enabled
	0~32000	ms	100	Effective Immediately
Po325	Deceleration time of internal position 8			<u>Internal register position</u>
	Setting range	Setting unit	Mfr's value	When enabled
	0~32000	ms	100	Effective Immediately

The setting of position, accel/decel time and interval time for 8-stage position is as below:

Po349	Circulation times of multistage internal position Internal register position			
	Setting range	Setting unit	Mfr's value	When enabled
	0~30000	N/A	0	Effective Immediately
Po366	Interval time 1 Internal register position			
	Setting range	Setting unit	Mfr's value	When enabled
	0~32000	ms	0	Effective Immediately
Po367	Interval time 2 Internal register position			
	Setting range	Setting unit	Mfr's value	When enabled
	0~32000	ms	0	Effective Immediately
Po368	Interval time 3 Internal register position			
	Setting range	Setting unit	Mfr's value	When enabled
	0~32000	ms	0	Effective Immediately
Po369	Interval time 4 Internal register position			
	Setting range	Setting unit	Mfr's value	When enabled
	0~32000	ms	0	Effective Immediately
Po370	Interval time 5 Internal register position			
	Setting range	Setting unit	Mfr's value	When enabled
	0~32000	ms	0	Effective Immediately
Po371	Interval time 6 Internal register position			
	Setting range	Setting unit	Mfr's value	When enabled
	0~32000	ms	0	Effective Immediately
Po372	Interval time 7 Internal register position			
	Setting range	Setting unit	Mfr's value	When enabled
	0~32000	ms	0	Effective Immediately
Po373	Interval time 8 Internal register position			
	Setting range	Setting unit	Mfr's value	When enabled
	0~32000	ms	0	Effective Immediately

c) Internal position sequence diagram

Once any preset position is selected by input contacts SD0~SD2 then require a trigger signal from the input contact CTRG, enabled trigger signal to start operation.

Diagram below shows an example for absolute move.

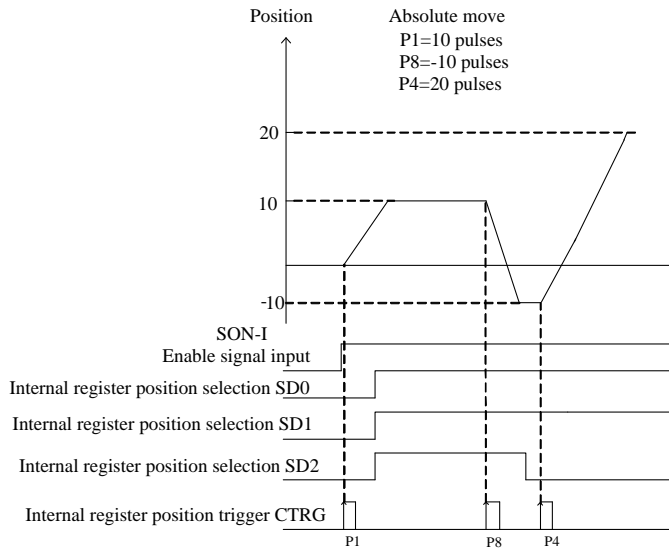

The Position command can be inhibited at any time by input contact signal HOLD.

Once HOLD is initiated the motor will decelerate and stop. As soon as the input contact CTRG is triggered again the original position command will be completed. Diagram below shows HOLD function with incremental move.

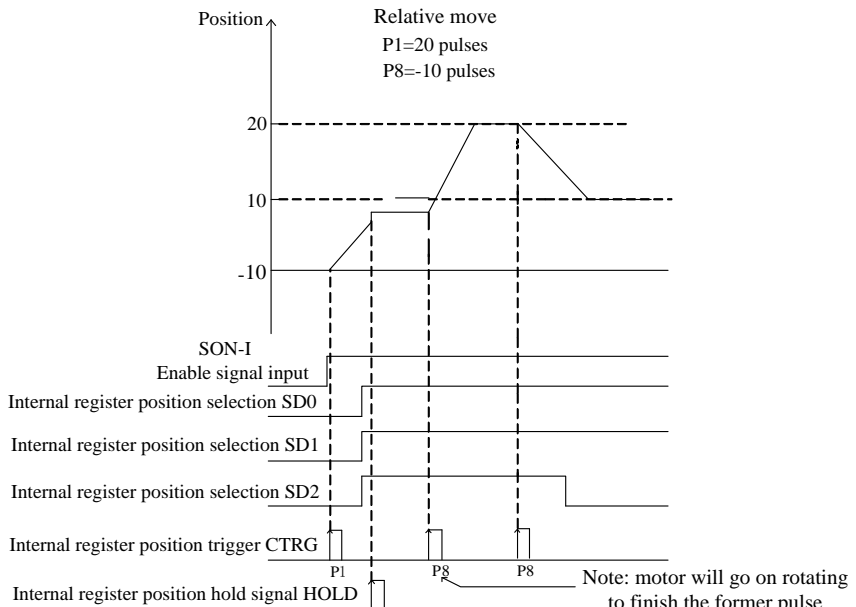

If the clear signal input is activated when a position command is in process then the motor will stop

Immediate and the remaining positioning pulses will be cleared. Once the CTRG input contact is activated again then a new position command will be started according to the selection of input contacts SD0~SD2 Diagram below shows clear function with incremental encoder.

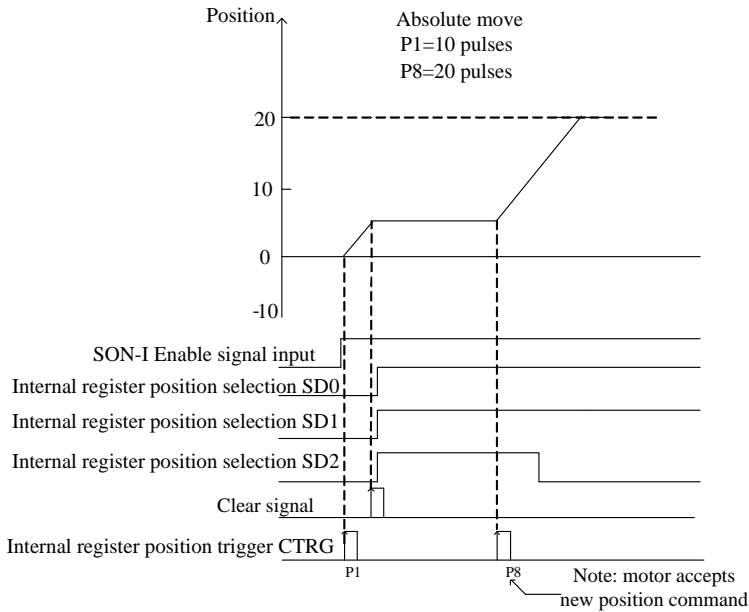

d) Multi-stage position circulation diagram

The diagram after setting interval time:

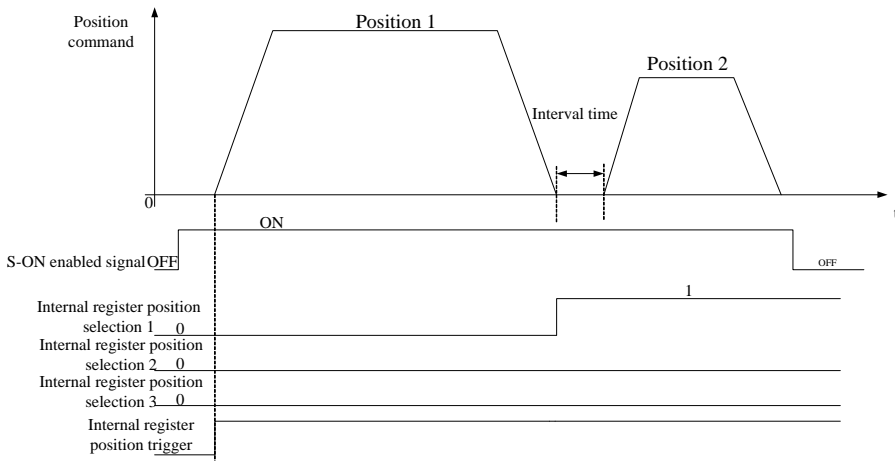

When interval time is 0, multi-stage position circulate diagram is as below:

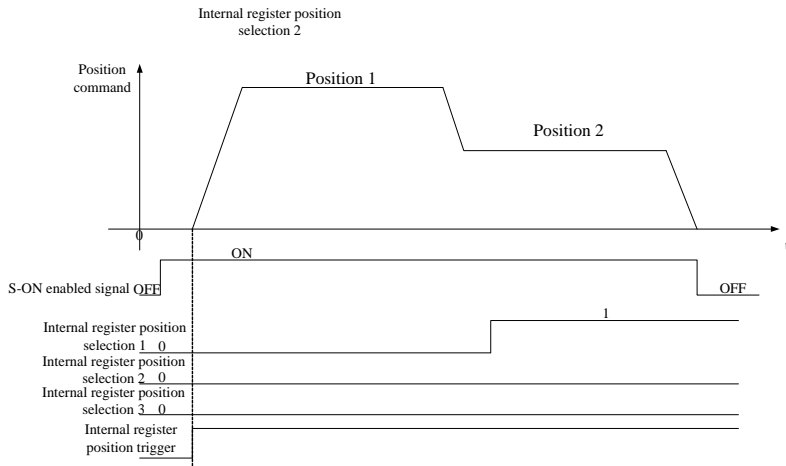

When termination signal is shown, the diagram is as below:

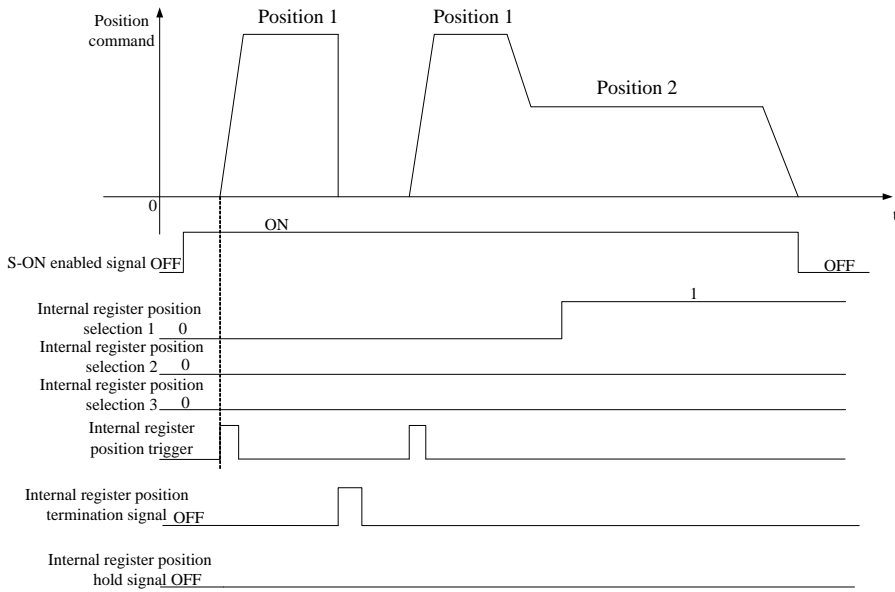

When Hold signal is shown, the diagram is as below:

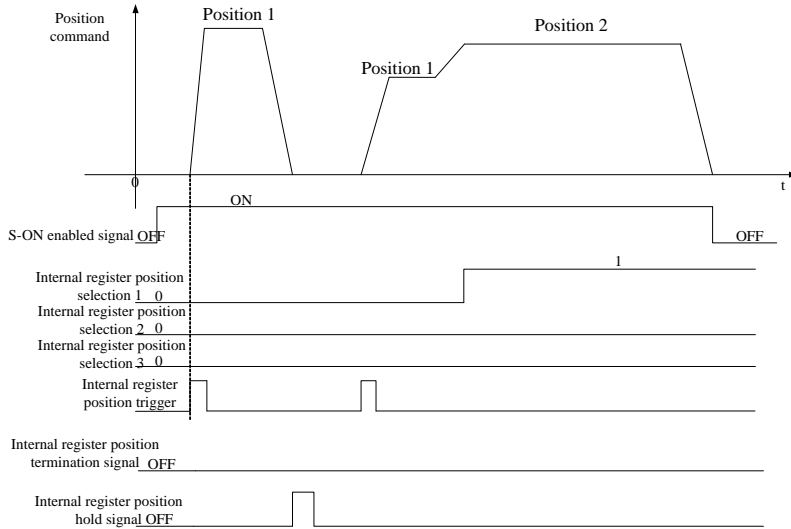

When enabled signal is OFF, the diagram is as below:

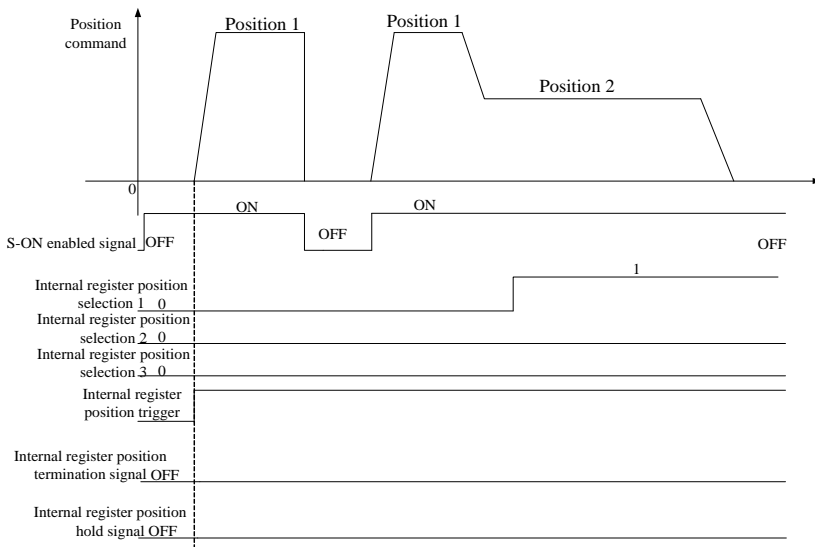

6.4.2 Setting electronic gear

1) Electronic gear

At the position control mode, input position command (command unit) is used to set load travel, motor position command (Encoder unit) is used to set motor travel. Electronic gear ratio is used to set proportional relation between motor position command and input position command.

2) Procedure for setting the electronic gear ratio

Step	Operation	Description
1	Check machine specifications.	Check the reduction ratio, ball screw lead, and pulley diameter.
2	Check the encoder resolution of servo motor.	Check the number of encoder pulse for one revolution.
3	Travel per command pulse	Determine the travel per command pulse from the command controller
4	Calculate the number of command pulse per load shaft revolution	Calculate the number of command pulse for turning load shaft one revolution based on the previously determined command unit.
5	Calculate the electronic gear ratio.	Use the electronic gear ratio equation to calculate the ratio
6	Set parameters.	Set parameters using the calculated values.

Setting parameters procedure is as below:

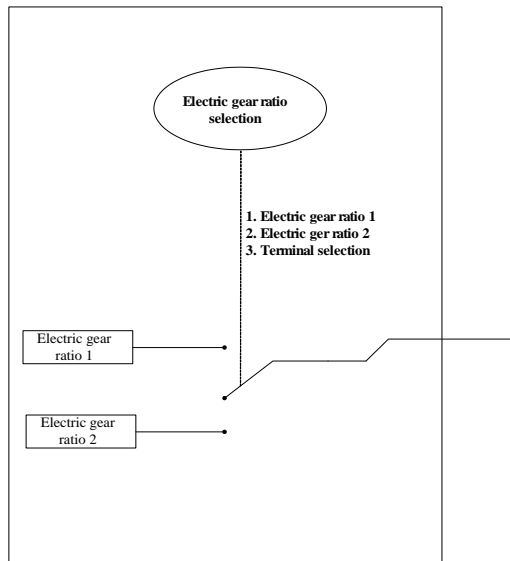

When Po304 and Po346 are not 0, electronic gear ratio equals to Po304/Po305 (Po344/Po346). If Po304 (Po344)=0, pulse numbers of motor rotating a rotation is controlled by Po305 (Po304).

3) Related parameters

It needs 131072 pulses from servo drive to make a 17bit encoder rotate a rotation (when electronic gear is 1).

① Function code

Po304	1 st group electronic gear numerator			Position
	Setting range	Setting unit	Mfr's value	When enabled
	0~65535	N/A	0	Effective Immediately

Po305	1 st electronic gear denominator			Position
	Setting range	Setting unit	Mfr's value	When enabled
	1~65535	N/A	10000	Effective Immediately
Po344	2 ^{ed} group electronic gear numerator			Position
	Setting range	Setting unit	Mfr's value	When enabled
	0~2147483647	N/A	0	Effective Immediately
Po346	2 ^{ed} electronic gear denominator			Position
	Setting range	Setting unit	Mfr's value	When enabled
	1~2147483647	N/A	10000	Effective Immediately

② Electronic gear ratio switchover

If two groups of electronic gear ratio have large difference, motor speed fluctuates wildly when electronic gear ratio switchover. Po306 position command filter can smooth position switchover.

Po339	Electronic gear ratio selection			Position
	Setting range	Setting unit	Mfr's value	When enabled
	0~2	N/A	0	Effective Immediately
	0: First electronic gear ratio 1: Second electronic gear ratio 2: Two groups of electronic gear ratio switchover			

4) Instruction

The deceleration ratio is n/m, electronic gear numerator is B, and electronic gear denominator is A, so the setting value of electronic gear ratio is:

Note: The deceleration ratio is n/m where m is the rotation of the servo motor and n is the rotation of the load shaft.

$$B/A = \text{Po304/ Po305} = (\text{No. of encoder pulses} \times 4 / \text{travel distance per load shaft rotation}) \times (m/n)$$

The actual meaning of electronic gear is:

$$\frac{\text{Command pulse input}}{\text{Pulses numbers are X}} \times \frac{B}{A} \text{ Position command} \rightarrow Y = X \times \frac{B}{A}$$

* If the ratio is outside the setting range, reduce the fraction (both numerator and denominator) until you obtain integers within the range. Be careful not to change the electronic gear ratio (B/A).

Electronic gear ratio setting range: $0.01 \leq \text{Electronic gear ratio (B/A)} \leq 100$

If the electronic gear ratio is outside this range, the control precision will decrease.

Ex: The following example shows electronic gear ratio settings for ball screw which pitch is 6mm.

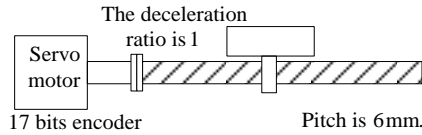

Fig 6-4-18 Setting electronic gear

Step	Operation	Calculation
1	Check machine specifications.	The deceleration ratio is 1:1 and the ball screw lead is 6mm.
2	Check the number of encoder pulses.	17 bits encoder
3	Determine travel per command pulse	The command unit is 1μm.
4	Calculate the number of command pulse per load revolution	$6000\mu\text{m}/1\mu\text{m}=6000$
5	Calculate the electronic gear ratio.	$B/A=(131072/6000) \times 1/1$
6	Set parameters.	Po304=8192 Po305=375

6.4.3 Position command filter

For the below situation, position command filter should be selected:

1. Position command of PC/PLC output is not dealt with by acceleration/deceleration.
2. The frequency of pulse command is high.
3. The electronic gear ratio is higher than 10 times.

Po306	Position loop filter time constant Position			
	Setting range	Setting unit	Mfr's value	When enabled
	1~10000	ms	1	Effective Immediately

Setting position loop filter time constant correctly can make motor rotate smoothly. The parameter does not affect pulse numbers.

Filter frequency is used to inhibit high-frequency of disturbance pulses. Please do not set this value too low, avoid inhibiting effective high-frequency pulse command.

6.4.4 Soft start of position command

Po343	Acceleration/deceleration time in position mode Position			
	Setting range	Setting unit	Mfr's value	When enabled
	0~10000	ms	0	Effective Immediately

Increasing the value of Po343 can make motor accelerate or decelerate stability, but response time will be increased. Otherwise, decreasing the value of Po343 will reduce motor stability.

Actual acceleration time=Po343 X target speed/rated speed

Actual deceleration time=Po345 X target speed/rated speed

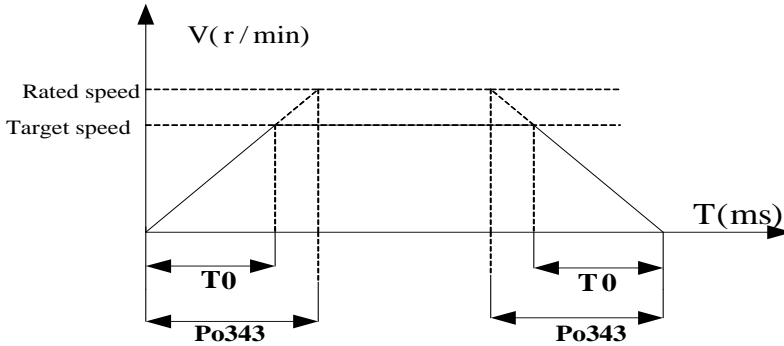

6.4.5 Position command inhibit function

This function inhibits the servodrive from counting input pulses during position control.

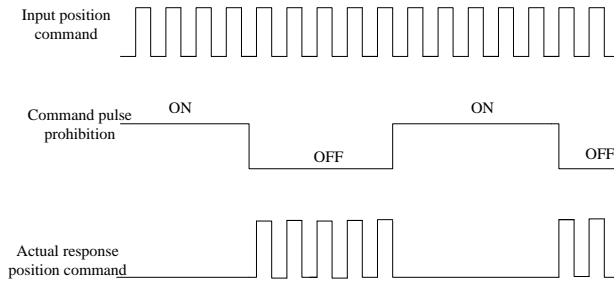

(1) Input signal

Signal name	Code	Default terminal	Remarks
Command pulse inhibit	INH-P	Must be allocated	Inhibiting the servodrive from counting input pulses, position pulse command is invalid.

(2) Setting parameters

Parameters	Remarks
Po308	b □□□0 Terminal of inhibiting command pulse is invalid.
	b □□□1 Terminal of inhibiting command pulse is valid.

6.4.6 Command pulse clear function

This function clears position deviation register during position control.

(1) Input signal

Signal name	Code	Default terminal	Remarks
Pulse clear	CLR	CN3-37 (at the mode of position pulse)	Clearing position deviation register during position control

(2) Setting parameters

Parameters		Remarks
Po308	b □□0□	Command pulse clear function is OFF.
	b □□1□	Command pulse clear function is ON.

6.4.7 Frequency-division output function

Encoder pulse is frequency-division processed by servo drive internal circuit, and orthogonal differential signal will output. The frequency-division signal setting is as below:

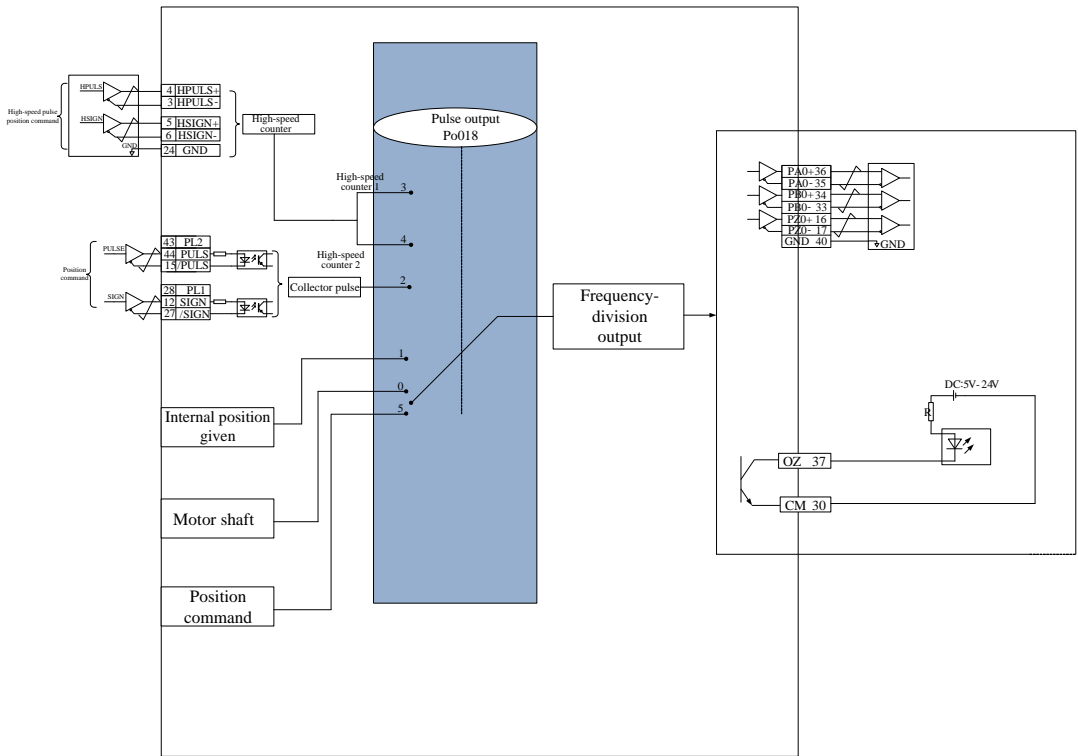

Fig 6.4.21 Frequency-division output diagram

(1) Output signal

Encoder pulse frequency-division signal has two output modes, one kind outputs PAO, PBO, PZO differential signal.

Signal name		Terminal code	Remarks
PA phase	PAO-	CN3 – 36	Encoder A phase pulse frequency-division output
	PAO+	CN3 – 35	
PB phase	PBO-	CN3 – 34	Encoder B phase pulse frequency-division output

	PBO+	CN3 – 33	
PZ phase	PZO-	CN3 – 16	Encoder Z phase home pulse output (no frequency-division)
	PZO+	CN3 – 17	
	OZ	CN3-37	Z phase open collector output

When output signal is frequency-division, output pulse source (Po018) and phase (Po300) should be set by actual requirement. When output source is motor shaft, and motor rotates one revolution, A/B phase output pulse numbers is controlled by Po003 (Molecule of encoder frequency-division numbers), width is controlled by motor speed.

When output signal is Z phase open collector output, pulse output setting (Po018) should be set by actual requirement. At high-speed, Z pulse is narrow, and it can be adjusted by Po017.

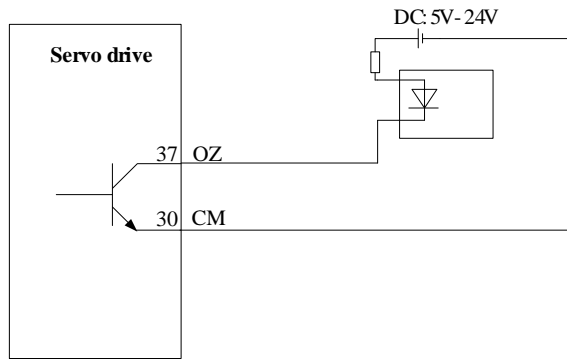

(2) Related parameters

Po003	Molecule of encoder frequency-division numbers			<input type="checkbox"/> speed <input type="checkbox"/> position <input type="checkbox"/> torque
	Setting range	Setting unit	Mfr's value	When enabled
	1~65535	N/A	—	Effective Immediately
Po005	Denominator of encoder frequency-division numbers			<input type="checkbox"/> speed <input type="checkbox"/> position <input type="checkbox"/> torque
	Setting range	Setting unit	Mfr's value	When enabled
	1~2147483647	N/A	—	Effective Immediately
Po017	Z pulse output width			<input type="checkbox"/> speed <input type="checkbox"/> position <input type="checkbox"/> torque
	Setting range	Setting unit	Mfr's value	When enabled
	50~30000	N/A	—	Effective Immediately
Po018	Pulse output setting			<input type="checkbox"/> speed <input type="checkbox"/> position <input type="checkbox"/> torque
	Setting range	Setting unit	Mfr's value	When enabled
	Four-parameter	N/A	0001	Effective Immediately

	<table border="1"> <tr><td>A</td><td>Z pulse output polarity</td></tr> <tr><td>0</td><td>Negative polarity output</td></tr> <tr><td>1</td><td>Positive polarity output</td></tr> </table>	A	Z pulse output polarity	0	Negative polarity output	1	Positive polarity output	<table border="1"> <tr><td>B</td><td>Z pulse command source</td></tr> <tr><td>0</td><td>Motor shaft</td></tr> <tr><td>1</td><td>Virtual shaft</td></tr> </table>	B	Z pulse command source	0	Motor shaft	1	Virtual shaft		
A	Z pulse output polarity															
0	Negative polarity output															
1	Positive polarity output															
B	Z pulse command source															
0	Motor shaft															
1	Virtual shaft															
		<table border="1"> <tr><td>C</td><td>Pulse frequency-division command source</td></tr> <tr><td>0</td><td>Motor shaft</td></tr> <tr><td>1</td><td>Internal position given</td></tr> <tr><td>2</td><td>Collector pulse input</td></tr> <tr><td>3</td><td>High-speed counter 1</td></tr> <tr><td>4</td><td>High-speed counter 2</td></tr> <tr><td>5</td><td>Position command</td></tr> </table>	C	Pulse frequency-division command source	0	Motor shaft	1	Internal position given	2	Collector pulse input	3	High-speed counter 1	4	High-speed counter 2	5	Position command
C	Pulse frequency-division command source															
0	Motor shaft															
1	Internal position given															
2	Collector pulse input															
3	High-speed counter 1															
4	High-speed counter 2															
5	Position command															
Po300	b 0□□□	CCW phase output														
	b 1□□□	CW phase output														

Table 6.4.1 Encoder frequency-division output pulse

Po300.D (output pulse phase)	Forward rotation Pulse output	Reverse rotation Pulse output
0	<p>A phase is 90 degrees ahead of B phase.</p>	<p>B phase is 90 degrees ahead of A phase.</p>
1	<p>B phase is 90 degrees ahead of A phase.</p>	<p>A phase is 90 degrees ahead of B phase.</p>

Table 6.4.2 Z phase open collector output

Po018.A (output pulse phase)	Po017 (Z phase expansion)	Forward rotation Pulse output	Reverse rotation Pulse output
0	500		
1	500		

(3) Wiring terminals

Signal name		Terminal code	Remarks
PA phase	PAO-	CN3-35	Encoder A phase pulse frequency-division output
	PAO+	CN3-36	
PB phase	PBO-	CN3-33	Encoder B phase pulse frequency-division output
	PBO+	CN3-34	
PZ phase	PZO-	CN3-17	Encoder Z phase home pulse output (no frequency-division)
	PZO+	CN3-16	
	OZ	CN3-37	Z phase open collector output
	CM	CN3-30	

(4) Example of pulse frequency-division signal

Example: when Po003=16, Po005=32768, the each circle and each phase output pulse numbers of encoder is 16.

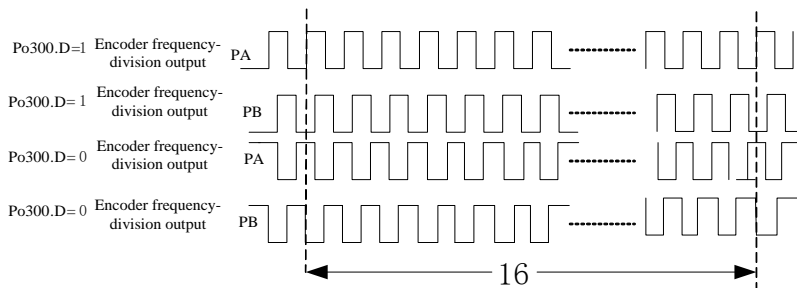

Fig 6-4-22 Encoder frequency-division output

When output signal is open collector output, frequency must not be higher than 100KHZ, Po003 should not be set too high.

6.4.8 HomeSearchMode

1) Introduction

Homesearch is the function of location and stop action (clamping) in the home pulse (Z-phase) position of encoder. In homesearch function, input contact ORGP(external detector input terminal) or Z-pulse can be used as home reference point, forward search or reversal search is adopted.

Instructions: 1. Using this function when setting position of motor shaft and machinery;

2. In the state that motor shaft is connected with machinery;

3. Ensure that the drive is enabled when using this function.

2) Parameters instructions

Po125	Selection of home search function			Position
	Setting Range	Unit	Mfr's value	Effect
0: No home searching 1:Auto when power-on 2:I/O port trigger 3:Start Immediate	N/A	0	Effective Immediately	

Name	Explanation	Remark
Po119= b0000	Reversal home searching	
Po119= b0001	Forward home searching	
Po119= b0000	Left-right position limitation as home reference	
Po119= b0010	Input terminal ORGP as home reference	
Po119= b0020	Nearest Z-phase pulse as home reference	
Po119= b0030	Searching mechanical origin	
Po119= b0000	Deceleration to stop after arriving at home reference	
Po119= b0100	Searching Z signal at second speed with opposite direction after arriving at home reference	
Po119= b0200	Searching Z signal at second speed with same direction after arriving at home reference	
Po119= b0300	Searching the rising edge of input terminal ORGP as the Mechanical origin at the second speed with opposite direction after arriving at the input terminal ORGP.	
Po119= b0000	Deceleration to stop after searching Z signal	
Po119= b1000	Turn back to Z signal after searching Z signal	

Note: Po119.C and Po119.D can only be set as 0 when using Left-right position limitation as origin reference.

Po120	Home/Mechanical origin searching at first speed Position			
	Setting range	Setting unit	Mfr's value	Effect
	0~20000	0.1r /min	500	Effective Immediately
Po121	Home/Mechanical origin searching at second speed Position			
	Setting range	Setting unit	Mfr's value	Effect
	0~10000	0.1r /min	200	Effective Immediately
Po122	Home/Mechanical origin searching acceleration/deceleration time Position			
	Setting range	Setting unit	Mfr's value	Effect
	0~1000	ms	0	Effective Immediately
Po123	Home searching offset pulse Position			
	Setting range	Setting unit	Mfr's value	Effect
	-2147483647~+2147483647	N/A	0	Effective Immediately
Po128	Home searching signal duration time Speed Position Torque			
	Setting range	Setting unit	Mfr's value	Effect
	1~30000	ms	100	Effective Immediately
Po129	Home searching timeout Speed Position Torque			
	Setting range	Setting unit	Mfr's value	Effect
	10~65535	ms	10000	Effective Immediately

3) Home Search Mode Start Sequence Chart

1. When servo drive is power-on, home search mode executes automatically (Po125=1)

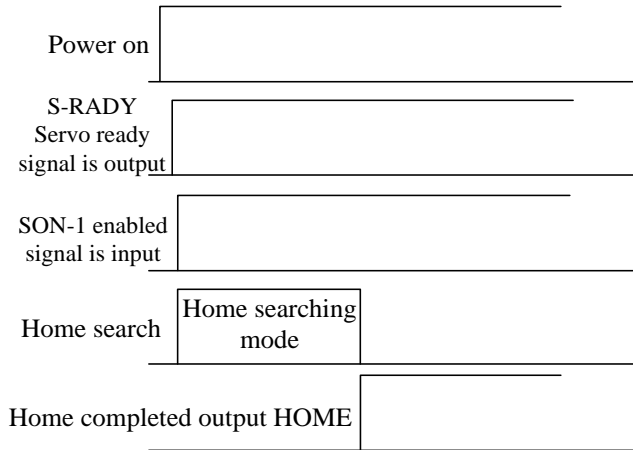

Fig 6.4.23 Home Search Mode Start Sequence Chart

2. Sequence Chart when inputting entry point (Po125=2)

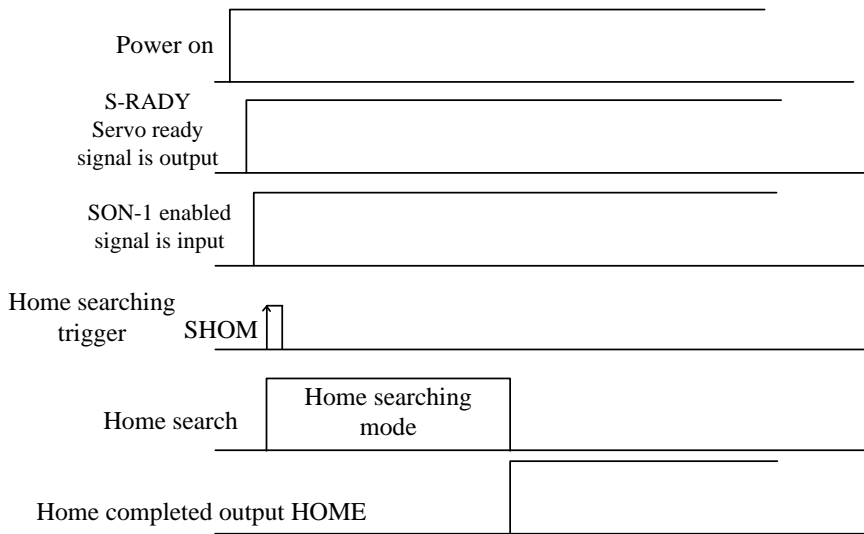

Fig 6.4.24 Sequence Chart when inputting entry point

4) Home Search Mode speed/position Sequence Chart

- 1. Po119.A= b□□□1 (Forward searching home reference at first speed after starting home search)
- Po119.C= b□1□□1 (Return back to search the nearest Z-phase pulse as Mechanical origin at the second speed with opposite direction after searching home reference)
- Po125.A= b□□□2 (Input I/O port to trigger home search)
- Po119.D= b1□□□ (Return back to Mechanical origin)

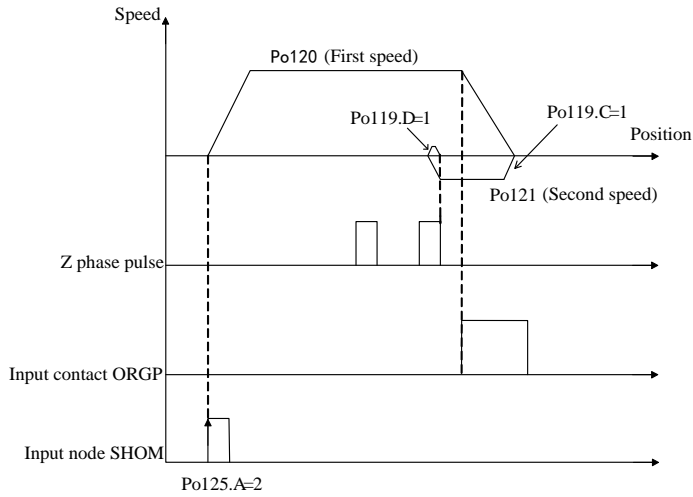

Fig 6.4.25 Forward home search at first speed

2. Po119.A= b□□□0 (Reversal searching home reference at first speed after starting home search)

Po119.C= b□1□□(Return back to search the nearest Z-phase pulse as Mechanical origin the second speed with opposite direction after searching home reference)

Po125.A= b□□□2(Input I/O port to trigger home search)

Po119.D= b1□□□(Return back to Mechanical origin)

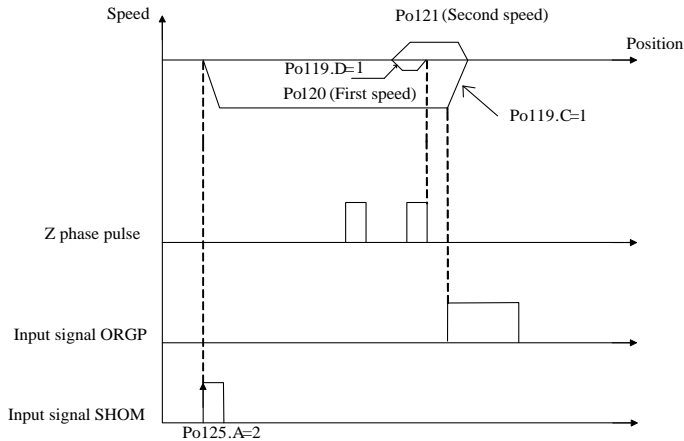

Fig 6.4.26 Reversal searching home at first speed

3. Po119.A= b□□□1(Forward searching home reference at first speed after starting home search)

Po119.C= b□2□□(Return back to search the nearest Z-phase pulse as Mechanical origin at the second speed with same direction after searching home reference)

Po125.A= b□□□2(Input I/O port to trigger home search)

Po119.D= b1□□□(Return back to Mechanical origin)

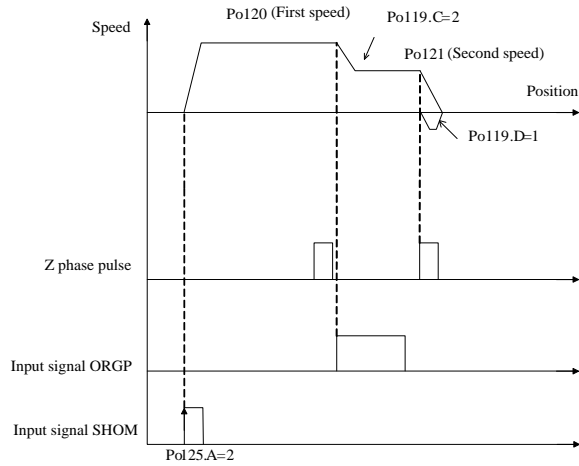

Fig 6.4.27 Forward home search at first speed

4. Po119.A= b□□□0 (Reversal searching home reference at first speed after starting home search)

Po119.C= b□2□□(Return back to search the nearest Z-phase pulse as Mechanical origin at second speed with same direction after searching home reference)

Po125.A= b□□□2(Input I/O port to trigger home search)

Po119.D= b1□□□(Return back to Mechanical origin)

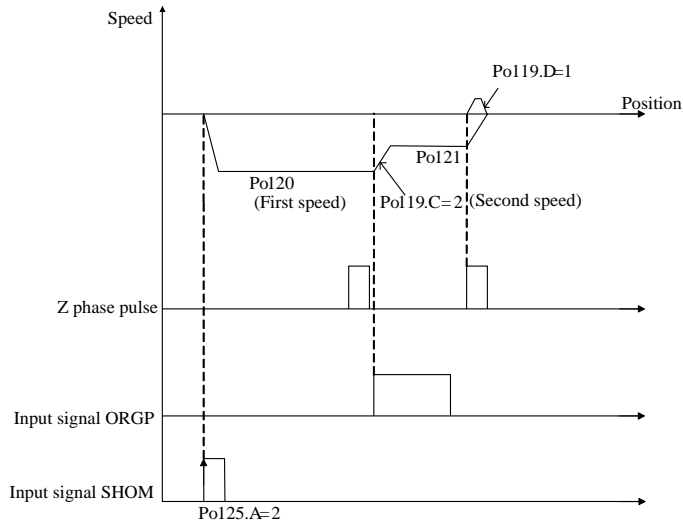

Fig 6.4.28 Reversal home searching at first speed

5. Po119.A= b□□□1 (Forward searching home reference at first speed after starting home search)

Po119.B= b□2□□(Searching Z-phase pulse as Mechanical origin)

Po125.A= b□□□2(Input I/O port to trigger home search mode)

Po119.D= b1□□□(Return back to Mechanical origin)

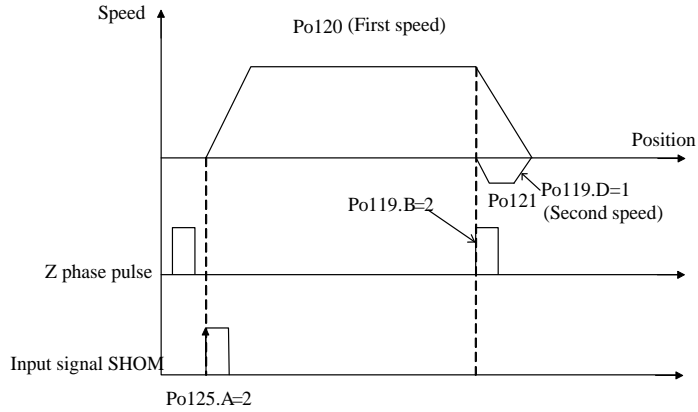

Fig 6.4.29 Forward home search at first speed

6. Po119.A= b□□□0(Reversal searching home reference at first speed after starting home search)

Po119.B= b□□2□(Search Z-phase pulse as Mechanical origin)

Po125.A= b□□□2(Input I/O port to trigger home search mode)

Po119.D= b1□□□(Return back to Mechanical origin)

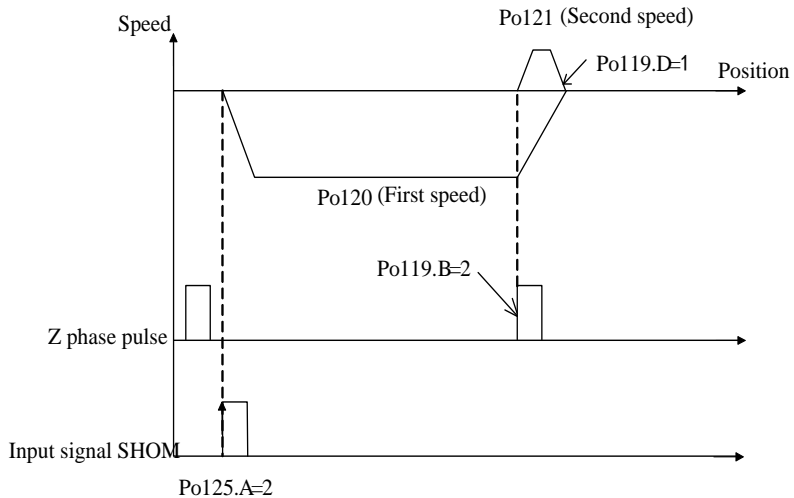

Fig 6.4.30 Reversal home searching at first speed

7. Po119.A= b□□□1(Forward home searching at first speed after starting home search)

Po119.C= b□3□□(Search the rising edge of home reference ORGP as Mechanical origin)

Po125.A= b□□□2(Input I/O port to trigger home search mode)

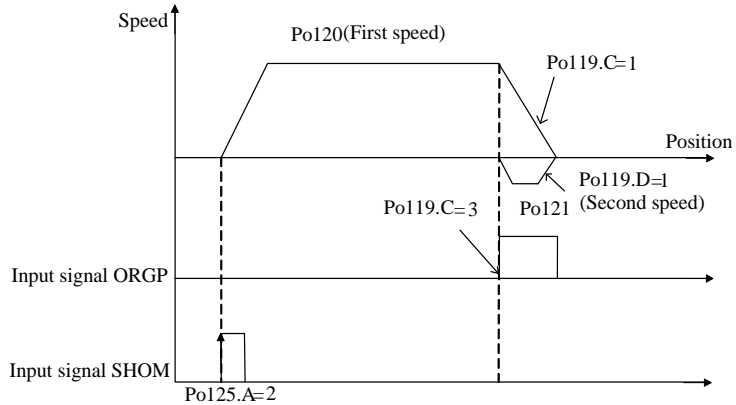

Fig 6.4.31 Forward home searching at first speed

- 8. Po119.A= b□□□0 (Reversal home searching at first speed after starting home search)
- Po119.C= b□3□□ (Search the rising edge of home reference ORGP as mechanical origin)
- Po125.A= b□□□2 (Input I/O port to trigger home search mode)

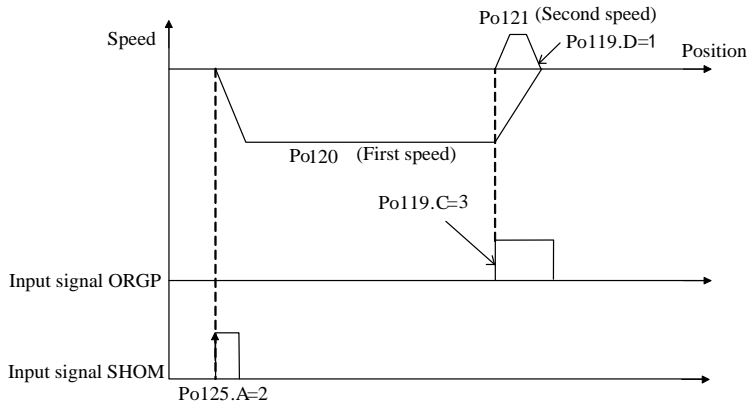

Fig 6.4.32 Forward home searching at first speed

6.4.9 Mechanical Origin Search Function

1) Introduction

Mechanical origin search is the function of location and stop action (clamping) through the absolute position memorized by absolute encoder.

Instructions:

1. After installing machine, set the mechanical origin firstly before servo drive is enabled;
2. Using this function when workpieces need to return to initial position (mechanical origin);
3. In the state that motor shaft is connected with machinery;

4. Make sure servo drive is enabled and the battery is installed in the drive;

Set “mechanical origin” as initial position, the “mechanical origin” can be found in any position of forward/reverse motion range set by servo motor. AL-27 alarm will alerts if exceeding the setting motion range. See details in chapter 6.1.4.

2) Setting

Mechanical origin means that the physical origin position of machinery, which is also called initial position.

(1) Setting mode

a. Set current position as mechanical origin: After setting to the initial position of machinery, set So-48=1, So-41=1, then

Current position is mechanical origin, the data of current position inputs Po136, Po138 automatically.

b. Set arbitrary point as mechanical origin: Set single-turn, multi-turn positions of encoder by Po136, Po138, confirm mechanical origin.

【Note】 If using the mode of setting arbitrary point as mechanical origin to reset alarm when AL-24 alarm alerts, set Po136, Po138 firstly, then set So-48=1, So-41=1, the alarm can be reset.

(2) Parameters

So-41	Setting mechanical origin			Speed	Position	Torque
	Setting Range	Setting Unit	Mfr's Value	Effect		
	0~1	N/A	0	Effective Immediately		
	0: Not set mechanical origin; 1: Set current position as mechanical origin;					

Po136	Mechanical origin single-turn value			Speed	Position	Torque
	Setting Range	Setting Unit	Mfr's Value	Effect		
	0~214748364	N/A	0	Effective Immediately		
Po138	Mechanical origin multi-turn value			Speed	Position	Torque
	Setting Range	Setting Unit	Mfr's Value	Effect		
	0~214748364	N/A	0	Effective Immediately		

3) Mechanical Origin Search

(1) User Parameters

See chapter 6.4.8 for details;

(2) Sequence Chart

1. When servo drive is power-on, mechanical origin search mode executes automatically (Po125=1)

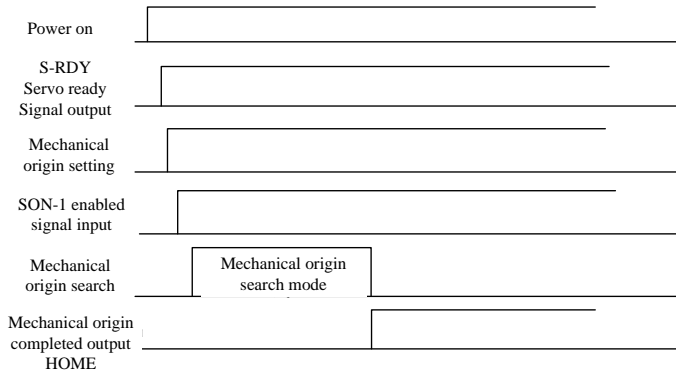

Fig 6.4.33 Mechanical origin search mode start sequence chart

2. Sequence chart when inputting entry point (Po125=2)

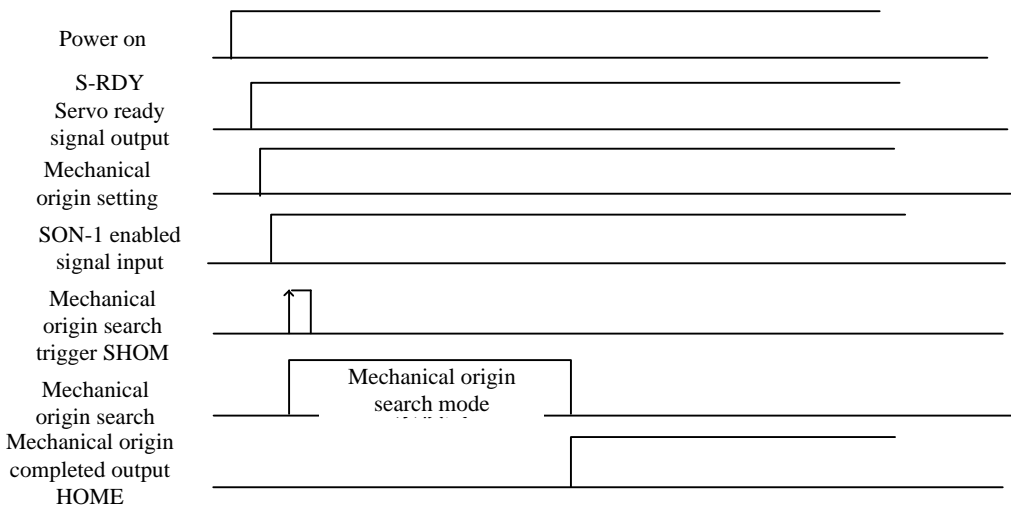

Fig 6.4.34 Sequence chart when inputting entry point

Note: Do not trigger mechanical origin search function in the running process of servo drive.

6.4.10 Fixed Length Interrupt Function

Fixed length interrupt: In external position pulse mode, interrupt current running status of servo, and execute preset fixed length instruction. In external position pulse mode, when interrupt terminal enabled, system receives interrupt trigger signal and motor cannot stop rotating instantly, but run for a while setting in internal position

mode.

During the operation period of fixed length interrupt, drive shields any other internal/external position instructions(including the instruction of re-trigger interrupt of fixed length position), when interrupt enabled terminal is valid, motor will run the setting length according to internal position mode after system receives interrupt trigger signal. When the interrupt terminal is valid, each interrupt rising edge triggers an internal position mode. After entering interrupt, interrupt indication is valid; position pulse and new interrupt will not be answered. After completing internal position mode, interrupt indication terminal is invalid and then interrupt terminal resets, when there is a rising edge, position pulse and new interrupt will be answered.

Fixed length interrupt operates as follow:

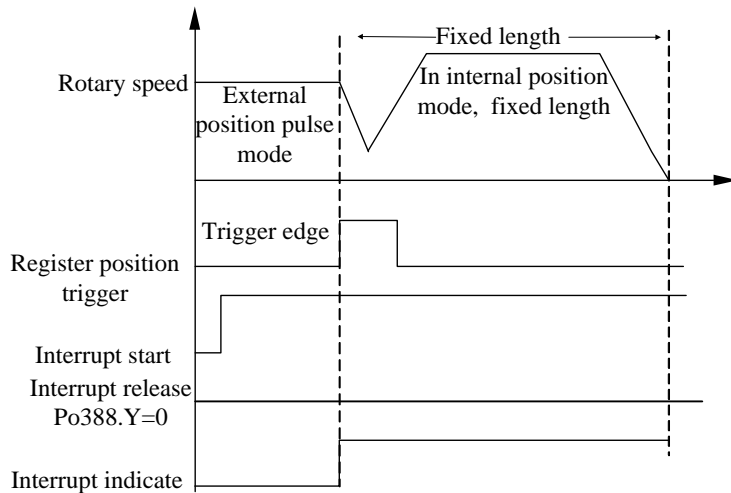

Fig 6.4.35 Running mode of fixed length interrupts

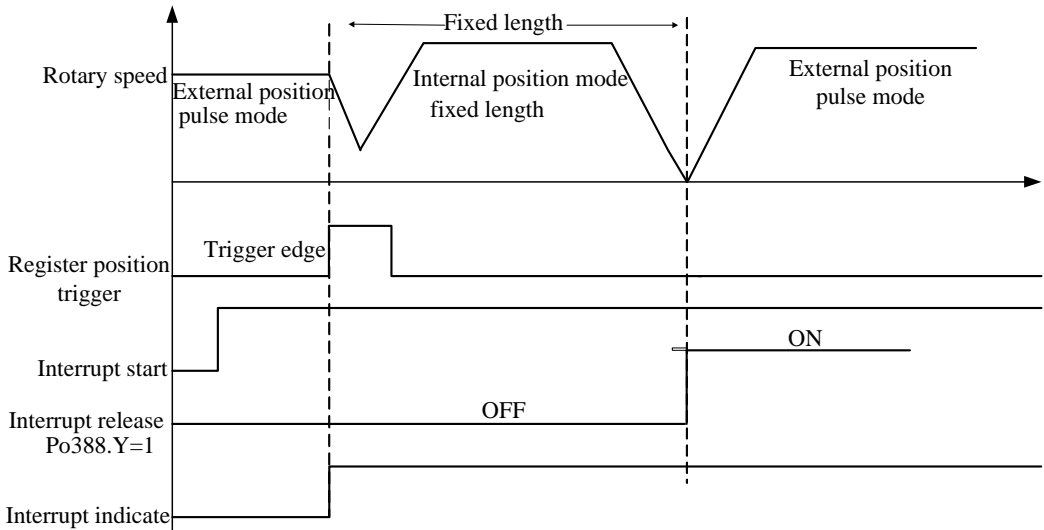

Fig 6.4.36 Sequence chart when controlling by fixed length interrupt

In the control of fixed length interrupt, if start fixed length interrupt release function and the interrupt release terminal keeps disabled, system will stay in the function of fixed length interrupt until the release terminal enabled, then servo can switch to external position pulse mode.

(1) Related parameter

Po388	Fixed length interrupt			Position											
	Setting Range	Setting Unit	Mfr's Value	Effect											
	Two parameters	N/A	00	Effective Immediately											
	<div style="display: flex; align-items: center;"> <div style="margin-right: 10px;"> <input type="checkbox"/> A <input type="checkbox"/> B </div> <table border="1" style="border-collapse: collapse;"> <tr> <td style="text-align: center;">A</td> <td>Interrupt fixed length function</td> </tr> <tr> <td style="text-align: center;">0</td> <td>Invalid</td> </tr> <tr> <td style="text-align: center;">1</td> <td>Valid</td> </tr> <tr> <td style="text-align: center;">B</td> <td>Interrupt fixed length release terminal</td> </tr> <tr> <td style="text-align: center;">0</td> <td>Invalid</td> </tr> <tr> <td style="text-align: center;">1</td> <td>Valid</td> </tr> </table> </div>				A	Interrupt fixed length function	0	Invalid	1	Valid	B	Interrupt fixed length release terminal	0	Invalid	1
A	Interrupt fixed length function														
0	Invalid														
1	Valid														
B	Interrupt fixed length release terminal														
0	Invalid														
1	Valid														

6.4.11 DO output related to position pulse

Setting position reach pulse range: In the mode of position pulse, this parameter provides the basis that drive can complete positioning or not. The drive identifies the positioning completed when afterpulses in positional

deviation register is not larger than the range of position reach pulse. This parameter does not affect the final positional accuracy.

(1) Output signal

Signal	Abbr.	Default terminal	Purport
Position reach	P-CMP	P-CMP- (In position pulse mode) P-CMP+ (In position pulse mode)	Positioning completed

(2) Parameter Setting

Po307	Position reach pulses range Position			
	Setting Range	Setting Unit	Mfr's Value	Effect
	1~32000	N/A	—	Effective Immediately

Alarm of position loop tracking excessive error is a kind of malfunction for servo drive. In position pulse mode, when the value of positional deviation register is higher than (Po309*Rate Unit of position loop tracking error alarm), the alarm signal of excessive error will output.

Po309	Position error alarm pulses Position			
	Setting Range	Setting Unit	Mfr's Value	Effect
	1~32000	See Po308 setting	—	Effective Immediately

Parameter	Purport	
Po308	b 0□□	Position loop tracking error alarm rate unit is 1 pulse
	b 1□□	Position loop tracking error alarm rate unit is 100 pulses

6.4.12 Full closed loop function

Full closed loop control: Install position detection device (grating scale, encoder etc.) on moving part, and real-time feedback to the position of moving part, without the influence of environmental factors such as mechanical error, shape change caused by temperature, make final working parts reach integral excellent high-accuracy positioning system.

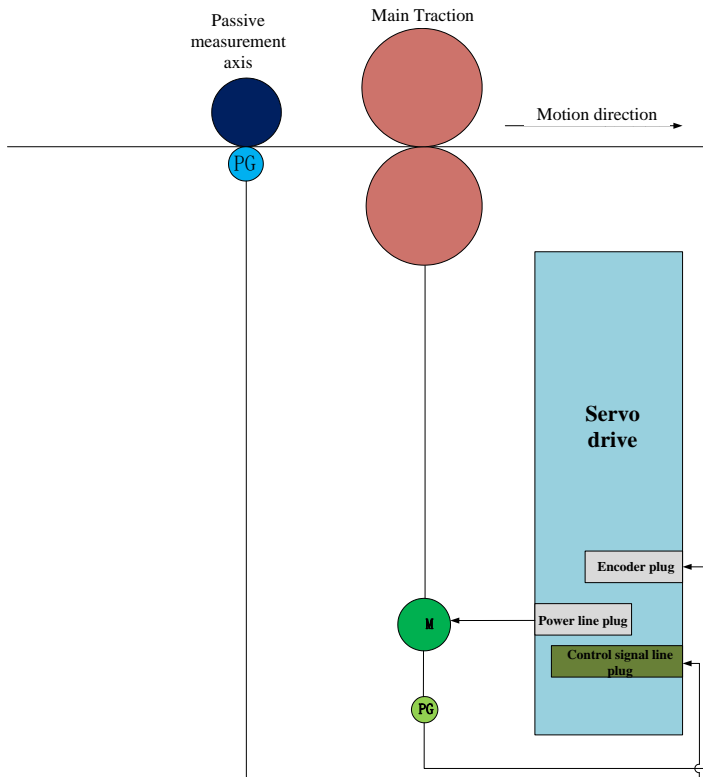

Fig 6.4.37 Full closed loop typical application sketch map

⚠ CAUTION

- ★ Connect power supply of servo and control circuit correctly, and also motor power line and encoder line;
- ★ JOG test run the servo drive by keypad to confirm the normal operation of motor;
- ★ Refer to the wiring instruction of Fig 6.4.37 or Fig 6.4.39, connectDI/DO;
- ★ Make the related settings for position mode;
- ★ Run servo drive, make sure the rotation direction of motor is normal firstly, then make gain adjustment, and please refer to 7.4 for gain adjustment.



CAUTION

Note: The servo only supports the encoder of differential type or open collector type for feedback of moving parts. One of the feedback encoder or pulse input signal must be differential signal.

Setting procedure of full closed loop shows as below:

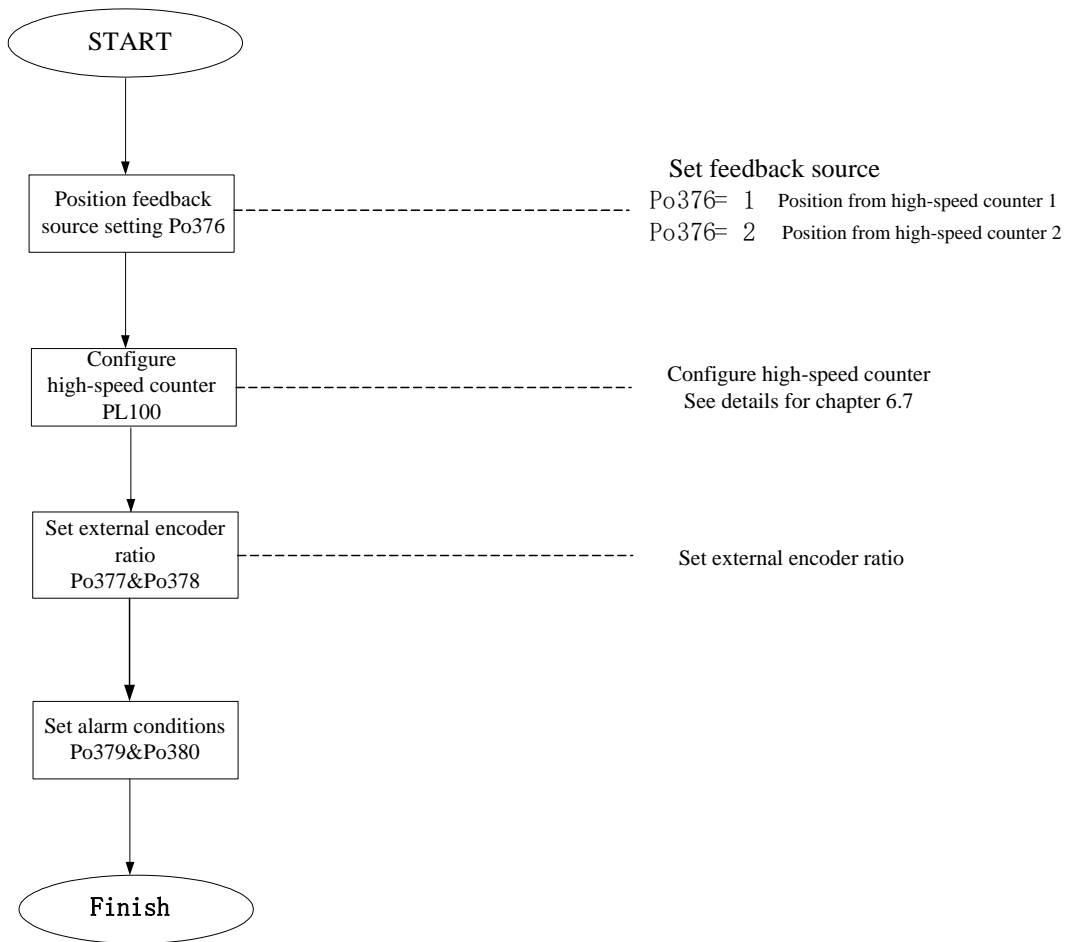

Fig 6.4.38 Full closed loop setting flow chart

(1) Parameter setting

1) Set position feedback source

Po376	Position feedback source Position			
	Setting Range	Setting Unit	Mfr's Value	Effect
	0~2	N/A	0	Effective Immediately

Name	Purport	Remark
Po376=0	Position feedback root in motor motor shaft	
Po376=1	Position feedback root in high-speed counter 1	
Po376=2	Position feedback root in high-speed counter 2	

2) External encoder electronic gear ratio setting

Po377	Position feedback pulse proportion numerator Position			
	Setting Range	Setting Unit	Mfr's Value	Effect
	1~65535	N/A	1	Effective Immediately
Po378	Position feedback pulse proportiondenominator Position			
	Setting Range	Setting Unit	Mfr's Value	Effect
	1~65535	N/A	1	Effective Immediately

The specific value of Po377 and Po378 is equal to the value that the encoder line number of servo motor divide by pulses of external encoder running if motor takes a turn.

3) Set alarm output

Po379	Mixed error remove turns Position			
	Setting Range	Setting Unit	Mfr's Value	Effect
	0~32000	N/A	0	Effective Immediately
Po380	Mixed error alarm pulses Position			
	Setting Range	Setting Unit	Mfr's Value	Effect
	1~65535	N/A	1000	Effective Immediately

If the error turns within Po379 exceed pulses set by Po380, the drive will jump to AL-31 alarm, error will be removed every turn of Po379.

(2) Wiring Instruction

FL20-SA Series

FL20 series servo drive has 2 group of pulse receiving circuits, one is for receiving the pulses of open collector type, and the other one is for receiving the pulses of differential type. When using the function of full closed loop, user should confirm the connections of servo based on PC/PLC and the output form of related encoder, do not wiring randomly. See below for details:

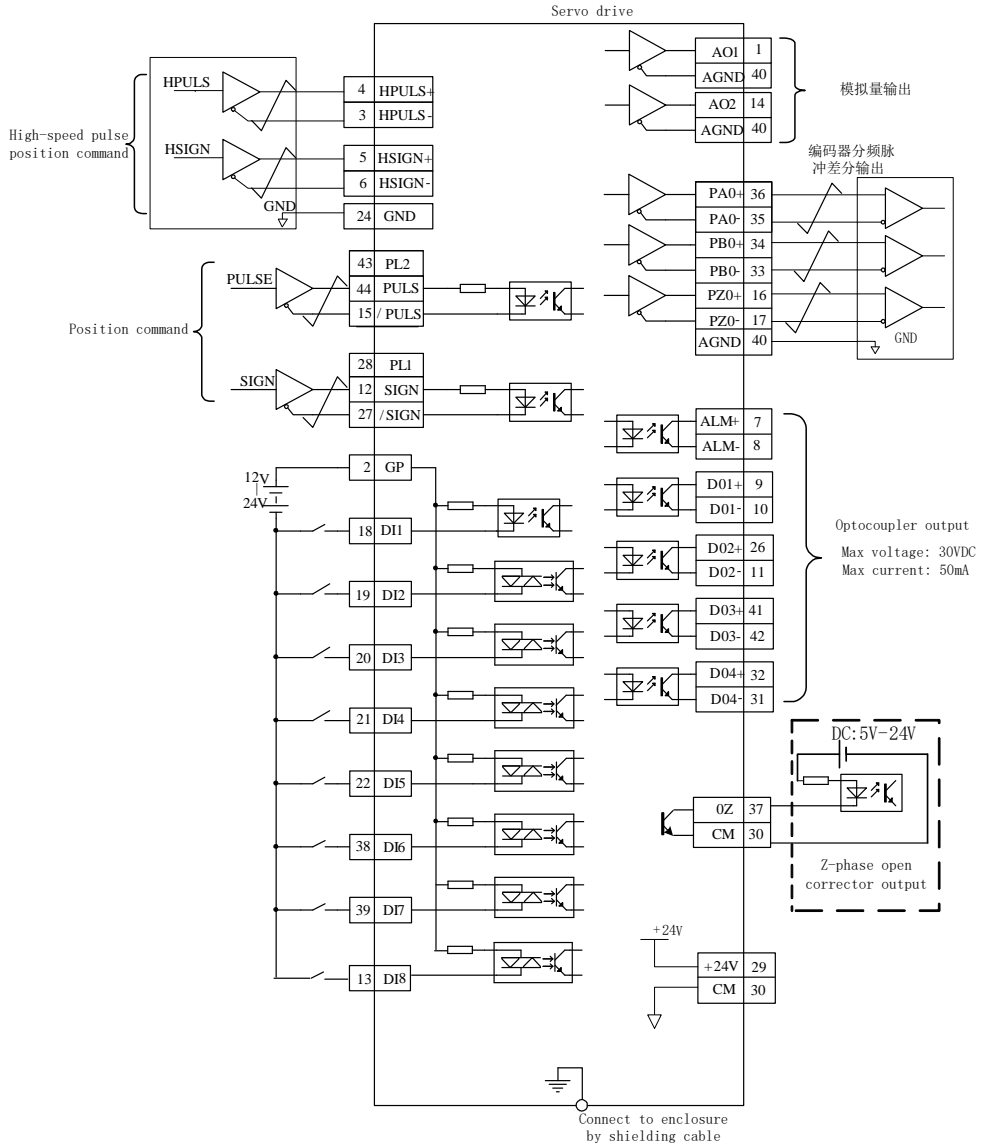

Fig 6.4.39 Full closed loop mode typical wiring diagram



- (1) One of the feedback encoder or pulse input signal must be differential signal;
- (2) DI1~DI8 terminals are programmable input terminals, and DO1~DO4 terminals are programmable output terminals. Users can redefine them by the situations.

6.4.13 Gantry Synchron Function

Gantry Synchron: PC/PLC sends pulse commands to two drives at the same time, make the feedback position pulse signals interact and sampling cross coupling through the encoders of two motors, to realize the adjustment for speed of the motor.

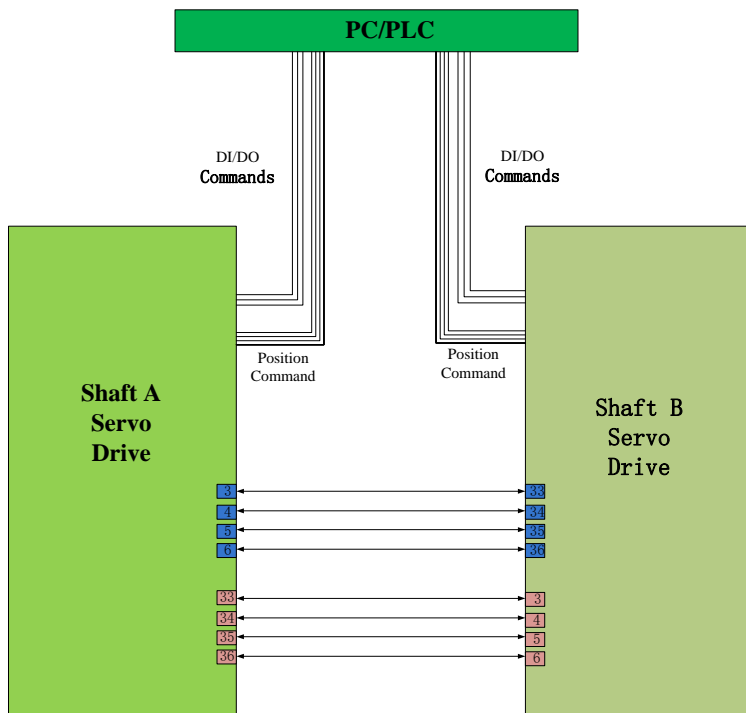

Fig 6.4.40 Gantry Synchron typical application wiring diagram



Caution

- ★ Connect power supply of servo main circuit and control circuit correctly, and also motor power line and encoder line;
- ★ JOG test run the servo drive by keypad to confirm the normal operation of motor;
- ★ Refer to the wiring instruction of Fig 6.4.40, connect DI/DO;
- ★ Make the related settings for position mode;

- ★ Run servo drive, make sure the rotation direction of motor is normal firstly, then make gain adjustment, and please refer to 7.4 for gain adjustment.

Gantry Synchron internal frame diagram shows as below:

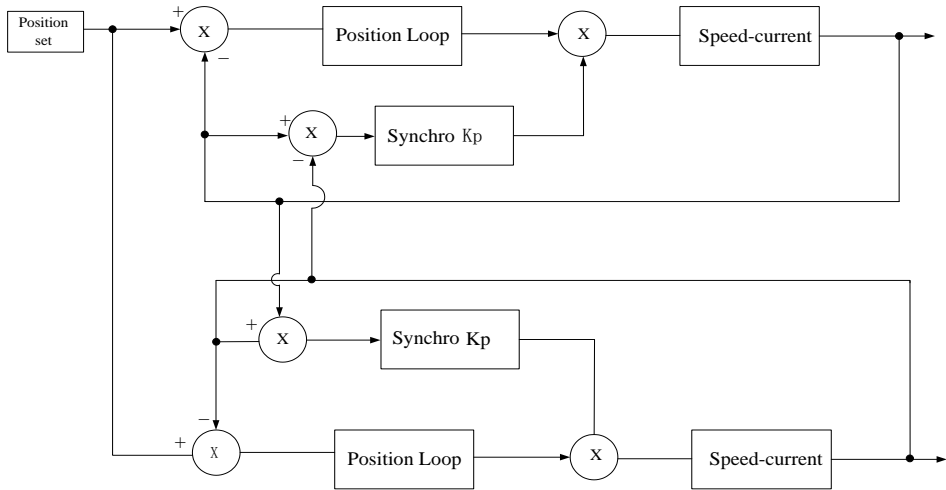

Fig 6.441Gantry Synchro typical application wiring diagram

⚠ The setting value of gantry synchro gain(Po381) must not exceed position-loop gain(Po301);

The setting procedure of gantry synchro is:

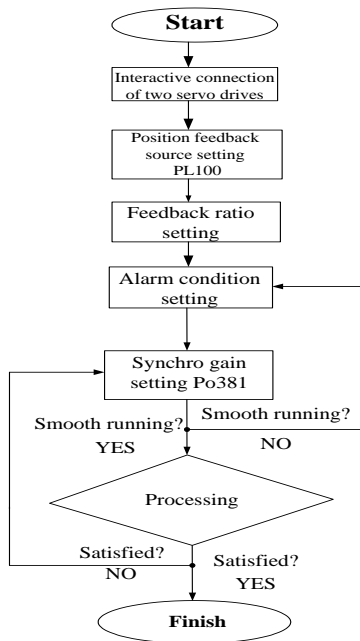

Fig 6.4.42 Gantry synchron setting flow chart

(1) User parameter setting

1) Position feedback source setting

Po382	Gantry position feedback source			Position
	Setting Range	Setting Unit	Mfr's value	Effect
	0~1	N/A	0	Effective Immediately
	0: high-speed counter 1; 1: high-speed counter 2;			

2) Feedback ratio setting

Po384	Gantry synchron feedback proportion numerator			Position
	Setting Range	Setting Unit	Mfr's value	Effect
	1~2147483647	N/A	10	Effective Immediately
Po386	Gantry synchron feedback proportion denominator			Position
	Setting Range	Setting Unit	Mfr's value	Effect
	1~2147483647	N/A	10	Effective

FL20-SA Series

				Immediately
--	--	--	--	-------------

3) Gain setting

Po381	Gantry synchron gain Position			
	Setting Range	Setting Unit	Mfr's value	Effect
	1~30000	N/A	1	Effective Immediately

The value of Po381 cannot be higher than the value of position-loop gain Po301.

4) Alarm output setting

Po383	Gantry synchron alarm pulse Position			
	Setting Range	Setting Unit	Mfr's value	Effect
	10~65535	N/A	1000	Effective Immediately

Alarm AL-32 given when synchro error is higher than Po383.

(3) Wiring Instruction

Gantry synchron needs interactive connection of two servo drives, which means that frequency dividing output of shaft A is connected to pulse input of shaft B, and frequency dividing output of shaft B is connected to the pulse input of shaft A. Typical wiring diagram shows as below:

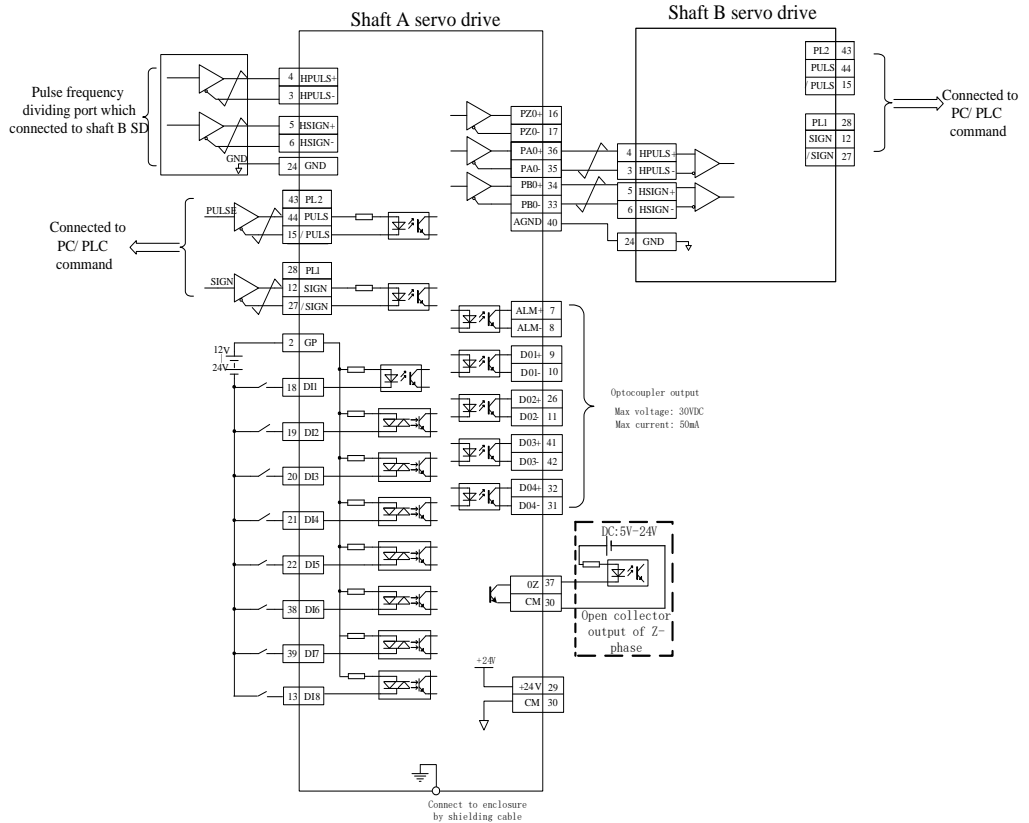

Fig 6.4.43 Gantry synchron typical wiring diagram



DI1~DI8 terminals are programmable input terminals, and DO1~DO4 terminals are programmable output terminals. Users can redefine them by the situations. The figure above only describes DI/DO of shaft A, which is similar with Shaft B

6.4.14 Electronic Cam (E-Cam) Function

Electronic cam (E-CAM): Servo drive programmes the positional relations of Master axis and Slave axis by its software, just as virtual cam exists between both axis. It uses electrical way to simulate the work of mechanical cam, so that it can realize the change of cam curve, and reduce mechanical cost, mechanical loss and maintenance.

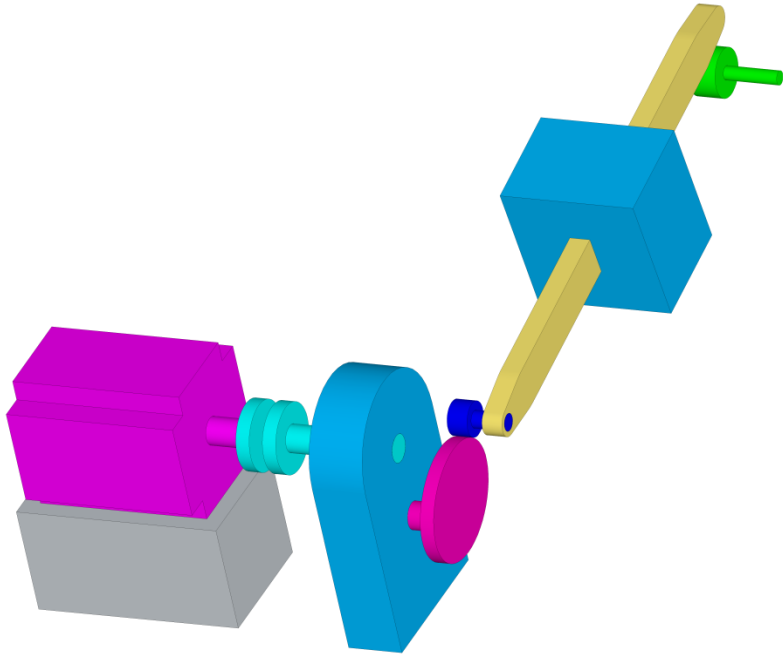

Fig 6.4.44FL20E-Cam internal frameworkdiagram

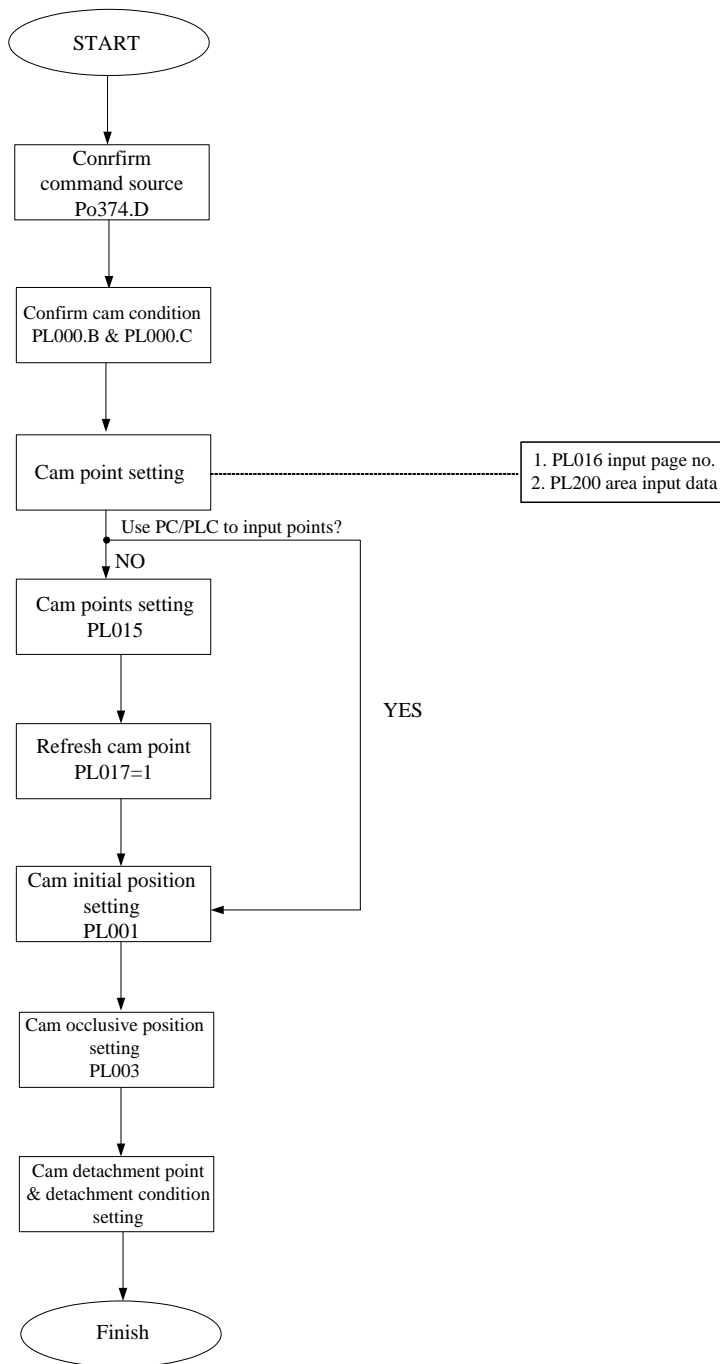

Fig 6.4.45 FL20 servo E-Cam setting flow chart

FL20-SA Series

Electronic cam which is provided by FL20 series servo drive, main feature of E-Cam is as the followings:

Features of E-CAM																			
Operation	Operate the E-cam in P mode only.																		
Active E-CamFunction PL000.A	PL000.A=0: disable E-cam function; PL000.A=1: enable E-cam function and starts to judge the engaged condition;																		
E-Cam Status	Engage/Stop/Pre-engage;																		
Driving shaft source	<ul style="list-style-type: none"> ● High-speed counter 1 ● High-speed counter 2 ● Internal position ● Timer axis (add 1 every 0.1ms) 																		
MotionCommand	Actual drive command=E-Cam command+position command																		
Data Storage Address	<p>Data array, start from PL200 area;The data of driving shaft ahead, driven shaft behind.</p> <p>In communication mode, for instance cam data is X, Y (both X and Y are 32 bits, value within the range of 32-bit directed number, X input is constant positive)</p> <p>The address starts from 1200:</p> <table style="width: 100%; border-collapse: collapse;"> <tr> <td style="text-align: left;">Storage address</td> <td style="text-align: center;">1200</td> <td style="text-align: center;">1201</td> <td style="text-align: center;">1202</td> <td style="text-align: center;">1203</td> <td style="text-align: center;">...</td> </tr> <tr> <td style="text-align: left;">Storage data</td> <td style="text-align: center;">X1-low</td> <td style="text-align: center;">X-high</td> <td style="text-align: center;">Y1-low</td> <td style="text-align: center;">Y1-high</td> <td style="text-align: center;">...</td> </tr> <tr> <td></td> <td style="text-align: center;">16-bit</td> <td style="text-align: center;">16-bit</td> <td style="text-align: center;">16-bit</td> <td style="text-align: center;">16-bit</td> <td></td> </tr> </table>	Storage address	1200	1201	1202	1203	...	Storage data	X1-low	X-high	Y1-low	Y1-high	...		16-bit	16-bit	16-bit	16-bit	
Storage address	1200	1201	1202	1203	...														
Storage data	X1-low	X-high	Y1-low	Y1-high	...														
	16-bit	16-bit	16-bit	16-bit															
Data Size	Decide by PL015, max 300 points, min 5 points; 6 pages in total, 50 for each page;																		
Data Format	32-bit signed value(+/-)																		
E-Cam Output	Digital Output(DO): E-CAM action output; If this DO is ON, it means that the E-Cam axis is in the setting range;																		

Flow Chart:

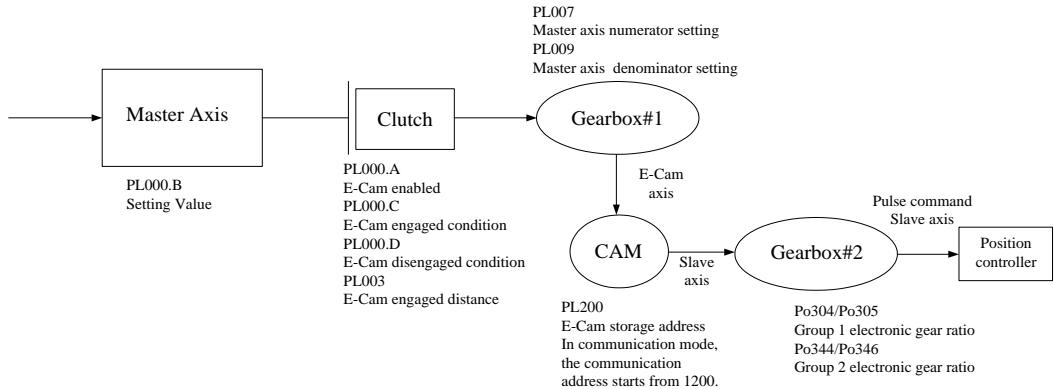

Master Axis:

Description:

★ Master Axis: main axis running by E-Cam of servo drive;

Function	The moving distance of the master axis is the signal source, which can drive E-cam running.
Source of Master Axis	Source of Master Axis is selected by PL000.B:
PL000.B	If PL000.B=0; command comes from high-speed counter 1; If PL000.B=1; command comes from high-speed counter 2; If PL000.B=2; command comes from internal position; If PL000.B=3; command comes from time;

● Clutch

Description:

★ Clutch: It is used to determine the status of engaged/ disengaged between the master axis and gearbox;

Function	To determine the status of engaged/ disengaged between master axis and gearbox #1.
Activate E-cam function	The start of driving shaft is decided by PL000.A: If PL000.A=0: disable E-cam. If the cam is engaged, it will be forced to disengage;
PL000.A	If PL000.A=1: enable E-cam and starts to judge the engaged condition;
E-Cam Status	When PL000.A=1, activate E-Cam function, E-cam is engaged after executing the instructions of PL003, only when cam is engaged, the moving distance of master axis can drive the cam running. The relationship of Engaged, Stop and Pre-engaged of E-cam as below:

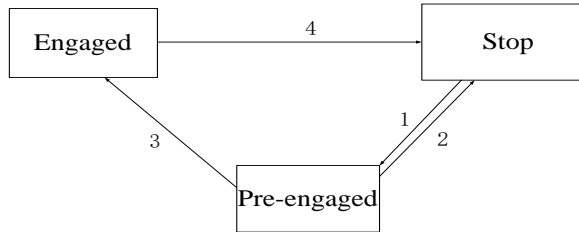

Statements:

●**Stop:** Initial status of the cam.The cam will not run with master axis pulse.
When PL000.A=0, cam will return to this state;

●**Pre-engaged:** when engagedcondition (path 1) is satisfied, it enters this status.The cam still will not run with master axis pulse, but it will execute the pulse value of PL003, then out of the state when executed.

Pay attention to the pulse actual given direction !

●**Engaged:** After pre-engaged (path 3)executed, it enters this status, the cam starts to run with master axis pules.

Pay attention to the pulse actual given direction !

Path Description:

Path 1: When the engaged condition is established, the status is from STOP to Pre-engaged. The lead pulse is determined by PL003;

Path 2: When the E-cam function is disabled (PL000A=0), it returns to STOP status.

Path 3: When lead pulse is executed, the status is from Pre-engaged to Engaged;

Path 4: When disengaged condition is established(PL000.D), it returns to STOP status;

●When the E-cam is in STOP status, the method of determeng engaged(path1) is as the followings:

EngagedCondition	1.PL000.C=0, Engaged Immediate;
PL000.C	2.DI: FunIN.32when CAM-AC is ON, E-cam is engaged; 3.CAP to engaged: E-cam is engaged when the CAP position is captured by hardware;
Disengaged Condition	When the E-cam is in Engaged status, the method of determine disengaged is as the followings:
PL000.D	1. Never disengaged; It will be forced to disengage until PL000.A=0;

- 2. DI setting: FunIN.32 When CAM-AC is off, the engaged status disabled;
- 3. Out of range: If master axis exceeds the setting moving distance PL005, the engaged status disabled;

● Gear #1

Description:

- ★ Gear #1: the module which is used to set the relation of master axis and E-cam axis;

Function	Set the relativity of master axis and E-cam axis E.g.: Master axis operates one cycle; the E-cam axis is no need to operate one cycle, which can be set by users.
Description	<ul style="list-style-type: none"> ● E-cam axis is a virtual axis ● The E-cam axis operates one cycle(360 degrees) means the cam operates one cycle and the slave axis operates one cycle ● The pulse number is the unit of moving distance of the master axis. Its resolution is determined by the source.
Setting Mode	If the pulse number of master axis is P, the E-cam axis operates M cycle. Then the setting of gear ratio: PL007=M, PL008=P

● CAM

Function	Set the relation between E-cam axis & slave axis and defined in the E-cam table E-cam axis operates one cycle and slave axis operates one cycle
Data Storage Address of E-Cam Table	Data array, the start address is set by PL200
Data Format of E-Cam Table	<ul style="list-style-type: none"> ● 32-bit (positive and negative). ● If input manually, start to input from PL200 area, which is master axis (PL202) and slave axis (PL203) respectively, and so on; ● If using communication, the address starts from 1200, the position of master axis ahead, the position of slave axis behind. When data storage, low byte is ahead, high byte is behind; ● The position data of slave axis is saved in E-cam table.
Data Content of E-Cam Table	<ul style="list-style-type: none"> ● If E-cam is divided into N areas, the position of each area must be included in the table. The position of the first point (0 degree) and the final point(360 degree) might not be the same. <ol style="list-style-type: none"> 1. The data of 0° and 360° is the same;

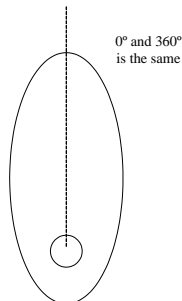

2. The data of 0° and 360° is different;

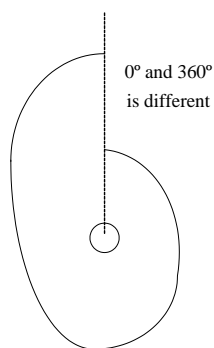

• Gear #2

Description:

★ Gear #2: the module which is used to set the relation of slave axis and pulse command;

Set the relation between slave axis and pulse command

Function

The slave axis operates a cycle, but the pulse command might not operate a cycle, which can be set by users

- The slave axis is a virtual axis and the unit of slave position is the unit of user

Description

- The pulse command is the encoder unit; the resolution is 131072pulse/rev.
- Rotating for one cycle of chart, the slave axis operates a cycle
- If the pulse number of slave axis is L, the motor axis operates R cycle,

Setting Mode

then the setting of gear ratio is:

$$Po304/Po305=131072*R/L;$$

$$Po344/Po346=131072*R/L;$$

【Note】

For the drives with different encoder, the value of electronic gear ratio is different, please pay attentions when using;

- 1、 The value of incremental encoder is 10000; The value of rotation transformer type encoder is 4096;

● Digital Output of E-cam

DO Name FunOUT.14CAM_AREA

Function DO: If it is ON, it means the position of E-cam axis is in the setting range

(1) User Parameter

1) Pulse Source Setting

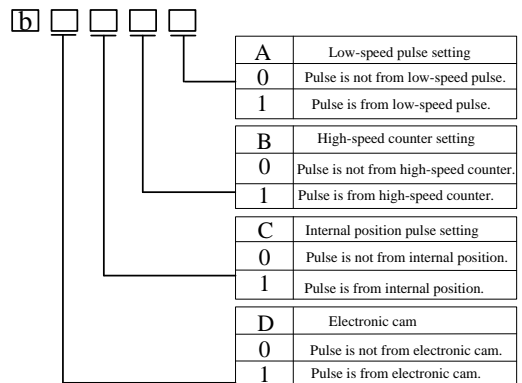
Po374	Position Pulse Command Source			Position
	Setting Range	Setting Unit	Mfr's Value	Effect
	Four parameters	N/A	0001	Effective Immediately
				

2) Cam Control Setting

PL000	E-Cam Control			Position
	Setting Range	Setting Unit	Mfr's Value	Effect
	Four parameters	N/A	0000	Effective Immediately

FL20-SA Series

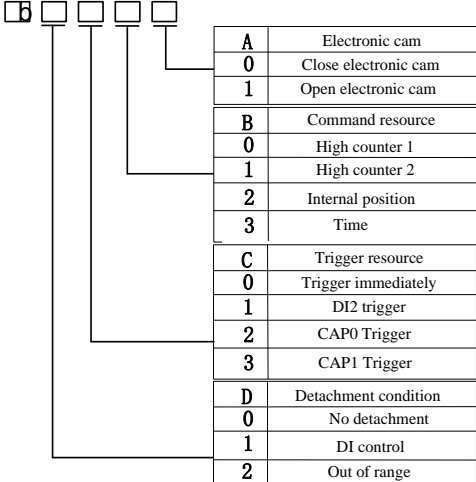
	 <table border="1" data-bbox="686 201 947 656"> <tr><td>A</td><td>Electronic cam</td></tr> <tr><td>0</td><td>Close electronic cam</td></tr> <tr><td>1</td><td>Open electronic cam</td></tr> <tr><td>B</td><td>Command resource</td></tr> <tr><td>0</td><td>High counter 1</td></tr> <tr><td>1</td><td>High counter 2</td></tr> <tr><td>2</td><td>Internal position</td></tr> <tr><td>3</td><td>Time</td></tr> <tr><td>C</td><td>Trigger resource</td></tr> <tr><td>0</td><td>Trigger immediately</td></tr> <tr><td>1</td><td>DI2 trigger</td></tr> <tr><td>2</td><td>CAP0 Trigger</td></tr> <tr><td>3</td><td>CAP1 Trigger</td></tr> <tr><td>D</td><td>Detachment condition</td></tr> <tr><td>0</td><td>No detachment</td></tr> <tr><td>1</td><td>DI control</td></tr> <tr><td>2</td><td>Out of range</td></tr> </table>				A	Electronic cam	0	Close electronic cam	1	Open electronic cam	B	Command resource	0	High counter 1	1	High counter 2	2	Internal position	3	Time	C	Trigger resource	0	Trigger immediately	1	DI2 trigger	2	CAP0 Trigger	3	CAP1 Trigger	D	Detachment condition	0	No detachment	1	DI control	2	Out of range
A	Electronic cam																																					
0	Close electronic cam																																					
1	Open electronic cam																																					
B	Command resource																																					
0	High counter 1																																					
1	High counter 2																																					
2	Internal position																																					
3	Time																																					
C	Trigger resource																																					
0	Trigger immediately																																					
1	DI2 trigger																																					
2	CAP0 Trigger																																					
3	CAP1 Trigger																																					
D	Detachment condition																																					
0	No detachment																																					
1	DI control																																					
2	Out of range																																					
PL001	E-cam Initial Position Position																																					
	Setting Range	Setting Unit	Mfr's Value	Effect																																		
	-2147483647~+2147483647	N/A	0	Effective Immediately																																		
PL003	E-cam Occlusion Contact Position																																					
	Setting Range	Setting Unit	Mfr's Value	Effect																																		
	-2147483647~+2147483647	N/A	0	Effective Immediately																																		
PL005	E-cam Occlusion Release Point Position																																					
	Setting Range	Setting Unit	Mfr's Value	Effect																																		
	-2147483647~+2147483647	N/A	0	Effective Immediately																																		
PL015	E-cam Points Position																																					
	Setting Range	Setting Unit	Mfr's Value	Effect																																		
	5~720	N/A	5	Effective Immediately																																		
PL016	E-cam Pages Position																																					
	Setting Range	Setting Unit	Mfr's Value	Effect																																		
	0~14	N/A	0	Effective Immediately																																		
PL017	E-cam Table Refresh Position																																					

FL20-SA Series

	Setting Range	Setting Unit	Mfr's Value	Effect
	0~1	N/A	0	Effective Immediately
	0: Cam Table no refresh; 1: Cam Table refresh;			
PL018	E-cam Table Status			Position
	Setting Range	Setting Unit	Mfr's Value	Effect
	0~3	N/A	0	Check
	0: Ready to start; 1: Waiting for engaged trigger; 2: Pre-engaged Status; 3: Running Status;			

PL021	E-cam disengaged is captured again or not			Position
	Setting Range	Setting Unit	Mfr's Value	Effect
	0~1	N/A	0	Effective Immediately

PL021=1, capture again. When selecting CAP trigger, the CAP and reset of high-speed counter are need to set as same source.

E.g.: Set PL012=1 for waiting for new CAP to engage after disengaged, if not, disengaged status happens even if getting new CAP signal before disengaged

PL022	Initial address of E-cam adjustment			Position
	Setting Range	Setting Unit	Mfr's Value	Effect
	0~300	N/A	0	Effective Immediately
PL023	Master axis variation			Position
	Setting Range	Setting Unit	Mfr's Value	Effect
	-2147483647~+2147483647	N/A	0	Effective Immediately
PL025	Slave axis variation			Position
	Setting Range	Setting Unit	Mfr's Value	Effect
	-2147483647~+2147483647	N/A	0	Effective

FL20-SA Series

				Immediately
--	--	--	--	-------------

After re-adjusting the initial address of cam, when refreshing cam table, the cam will start from PL022 address to add the setting value of PL023, PL025 for each point.

3) Master Axis Setting

PL007	E-cam master axis numerator Position			
	Setting Range	Setting Unit	Mfr's Value	Effect
	1~+2147483647	N/A	1	Effective Immediately
PL009	E-cam master axis denominator Position			
	Setting Range	Setting Unit	Mfr's Value	Effect
	1~+2147483647	N/A	1	Effective Immediately
PL019	Master Axis Position Position			
	Setting Range	Setting Unit	Mfr's Value	Effect
	0~2147483647	N/A	0	Check

4) Digital output setting

PL011	DO valid initial position Position			
	Setting Range	Setting Unit	Mfr's Value	Effect
	0~2147483647	N/A	0	Effective Immediately
PL013	DO valid ending position Position			
	Setting Range	Setting Unit	Mfr's Value	Effect
	0~2147483647	N/A	0	Effective Immediately

6.5 Dual Mode

6.5.1 User Parameter Setting

Po001 is two-parameter mode, which is selected by Po001.X.

Parameter	Significance	Remark
Po001= d □ 6	Speed and position pulse command of internal register	
Po001= d □ 7	Speed and torque of internal register	
Po001= d □ 8	Speed of internal register and speed of external analog	
Po001= d □ 9	Speed of internal register and torque of external analog	

FL20-SA Series

Po001= d □ 10	Speed and position of internal register	
Po001= d □ 11	Torque and position pulse command of internal register	
Po001= d □ 12	External analog speed and position pulse command	
Po001= d □ 13	External analog torque and position pulse command	
Po001= d □ 14	Position pulse command and position of internal register	
Po001= d □ 15	External analog speed and torque of internal register	
Po001= d □ 16	External analog torque and torque of internal register	
Po001= d □ 17	Torque and position of internal register	
Po001= d □ 18	External analog speed and torque	
Po001= d □ 19	External analog speed and internal register position	
Po001= d □ 20	External analog torque and internal register position	
Po001= d □ 21	Bus control mode	
Po001= d □ 22	Built-in PLC control mode	

6.5.2 Internal Speed And Position Pulse Dual Mode

Internal register speed and position pulse command switching mode shows as fig 6.5.1, after servo is enabled, servo runs as speed mode when internal speed selection signal is enabled; Servo runs as position mode when internal speed selection signal is disabled.

In the running process of speed mode, servo slows down to zero according to deceleration time when speed selection signal is disabled; Servo cannot receive position pulse until switching to position mode after position arrive signal output is enabled.

In the running process of position mode, when speed selection signal is enabled, servo switches to speed mode Immediate and run to target speed according to acceleration/deceleration time.

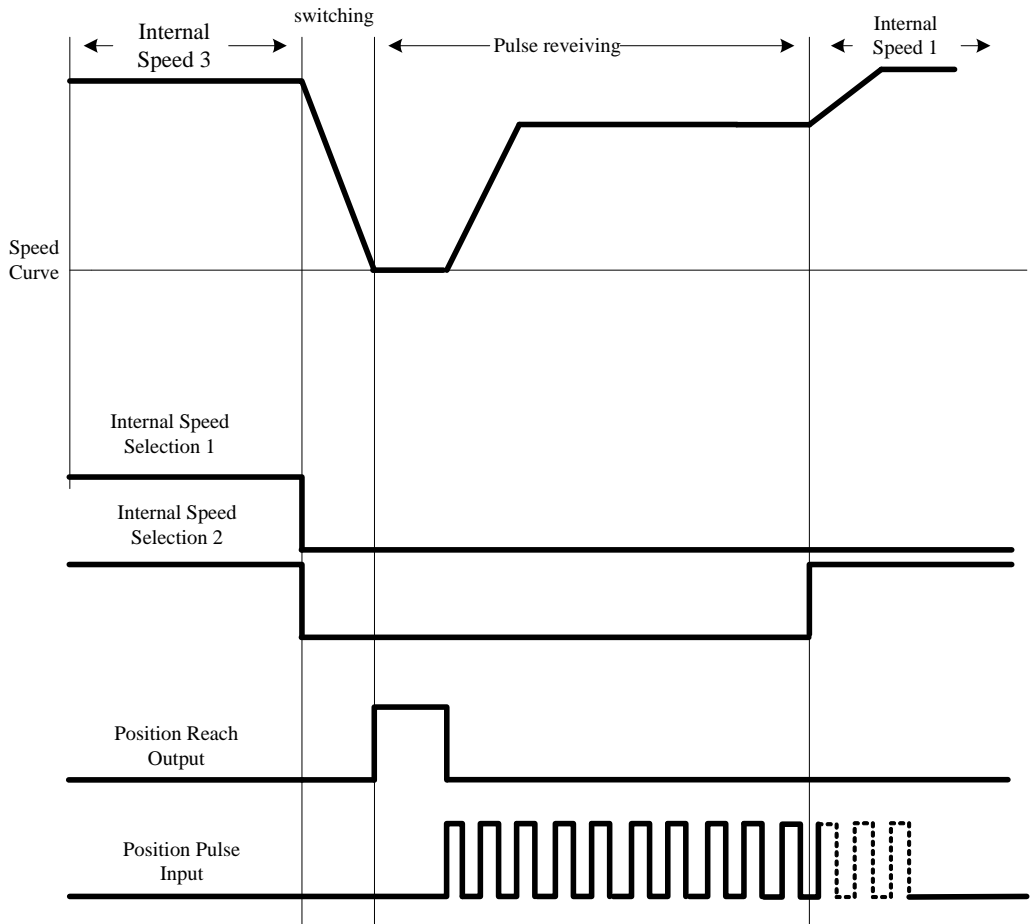

Fig 6.5.1 Speed and Position Pulse Switching Mode Sequence

6.5.3 Analog Speed and Position Pulse Dual Mode

External analog speed and position pulse command switching mode shows the figure 6.5.2, after servo is enabled, servo runs as position pulse mode when mode switching signal is enabled; Servo runs as analog speed when mode switching signal is disabled.

In the running process of analog speed mode, servo slows down to zero according to deceleration time when mode switching signal is enabled, servo cannot receive position pulse until switching to position mode after position reach signal output is enabled.

In the running process of position pulse mode, when mode switching signal is disabled, servo switches to analog speed mode Immediate, and run to target speed according to acceleration/deceleration time.

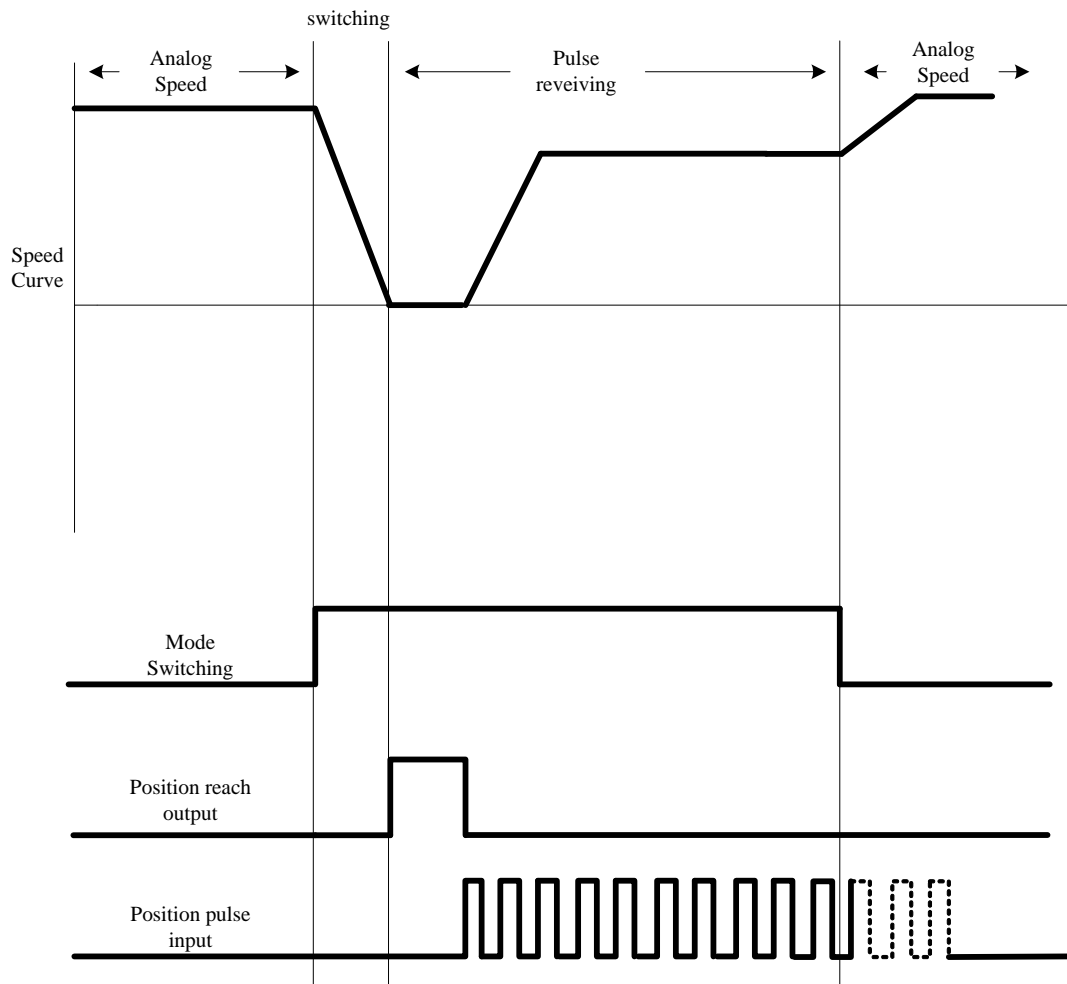

Fig 6.5.2 Analog speed and position pulse sequence diagram

6.5.4 Analog speed and internal register position dual mode

External analog speed and internal register position switching mode shows as figure 6.5.3, after servo is enabled, servo runs as internal register position mode when mode switching signal is enabled; servo runs as analog speed when mode switching signal is disabled.

In the running process of analog speed mode, servo slows down to zero according to deceleration time when mode switching signal is enabled; servo cannot receive internal register position trigger signal until switching to internal register position mode after position reach signal output is enabled.

In the running process of internal register position mode, when mode switching signal is disabled, servo switches to analog speed mode Immediate and run to target speed according to acceleration/deceleration

time.

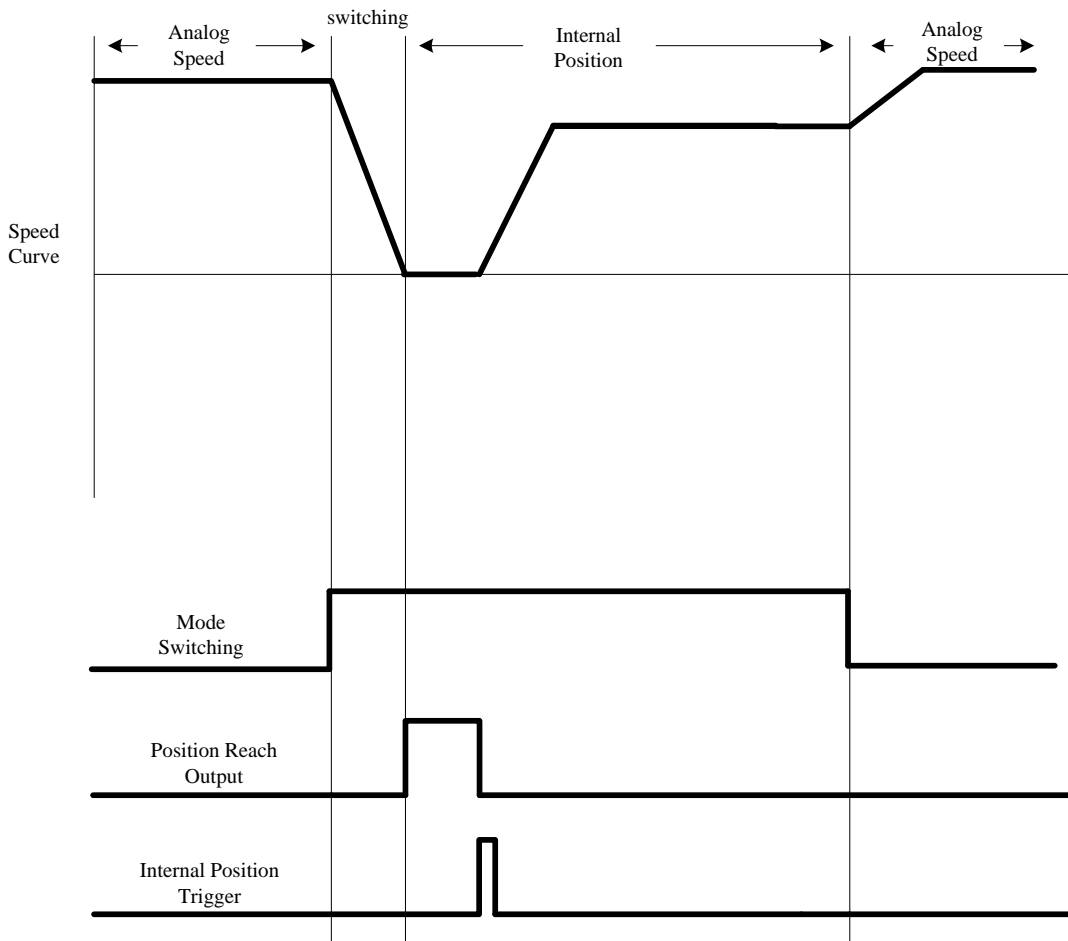

Fig 6.5.3 Analog speed and internal position pulse mode sequence diagram

6.5.5 Internal speed and internal register position dual mode

Internal register speed and position switching mode shows as figure 6.5.4, after servo is enabled, servo runs as speed mode when internal speed selection signal is enabled; Servo runs as internal register position mode when internal speed selection signal is disabled.

In the running process of speed mode, servo slows down to zero according to deceleration time when speed selection signal is disabled; servo cannot receive internal register position trigger signal until switching to position mode after position reach signal output is enabled.

In the running process of internal register position mode, when speed selection signal is enabled, servo switches to speed mode Immediate and run to target speed according to acceleration/deceleration time.

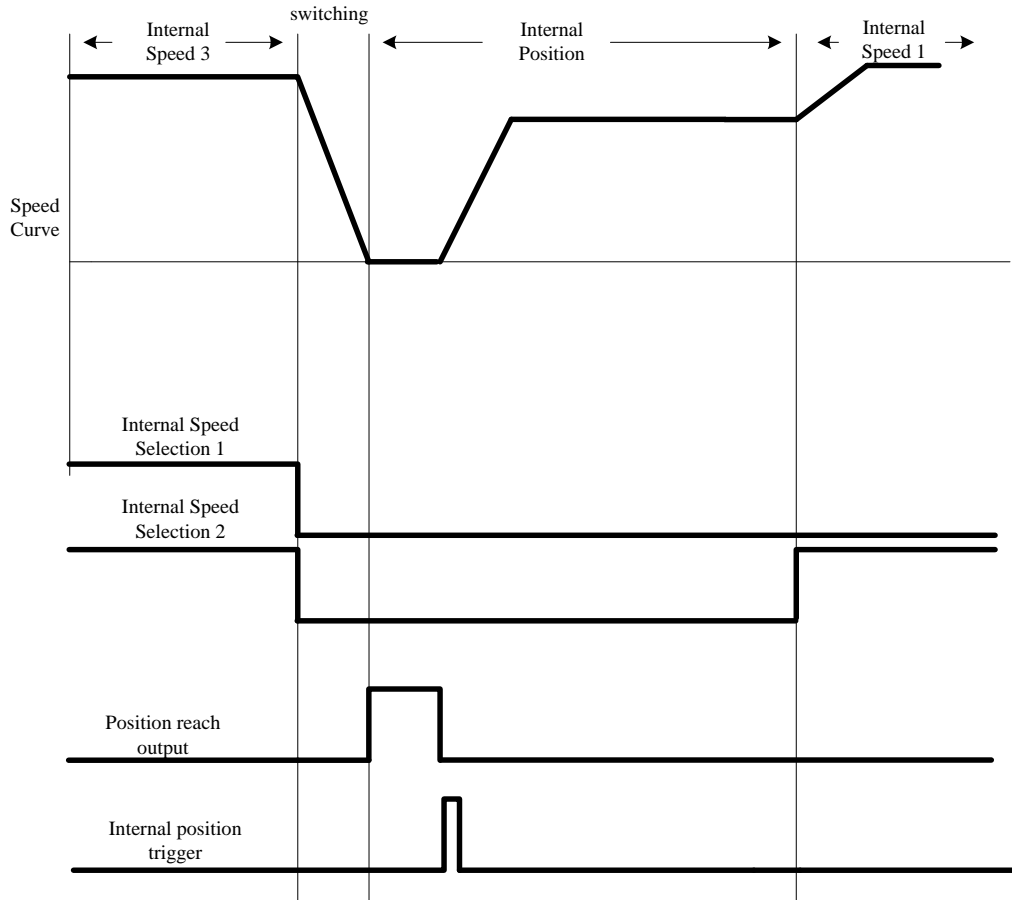

Fig 6.5.4 Internal speed and internal register position mode sequence diagram

6.5.6 Torque Mode and Position Pulse Dual Mode

Internal register torque and position pulse command switching mode , external analog torque and position pulsecommand switching mode shows as figure 6.5.5, after servo is enabled, servo runs as position mode when mode switching signal is enabled; Servo runs as torque mode when mode switching signal is disabled.

In the running process of torque mode, servo slows down to zero according to deceleration time when mode switching signal is enabled; servo cannot receive position pulse signal until switching to position pulse mode after position reach signal output is enabled.

In the running process of position pulse mode, when mode switching signal is disabled, servo switches to torque mode Immediate and run to target torque according to acceleration/deceleration time.

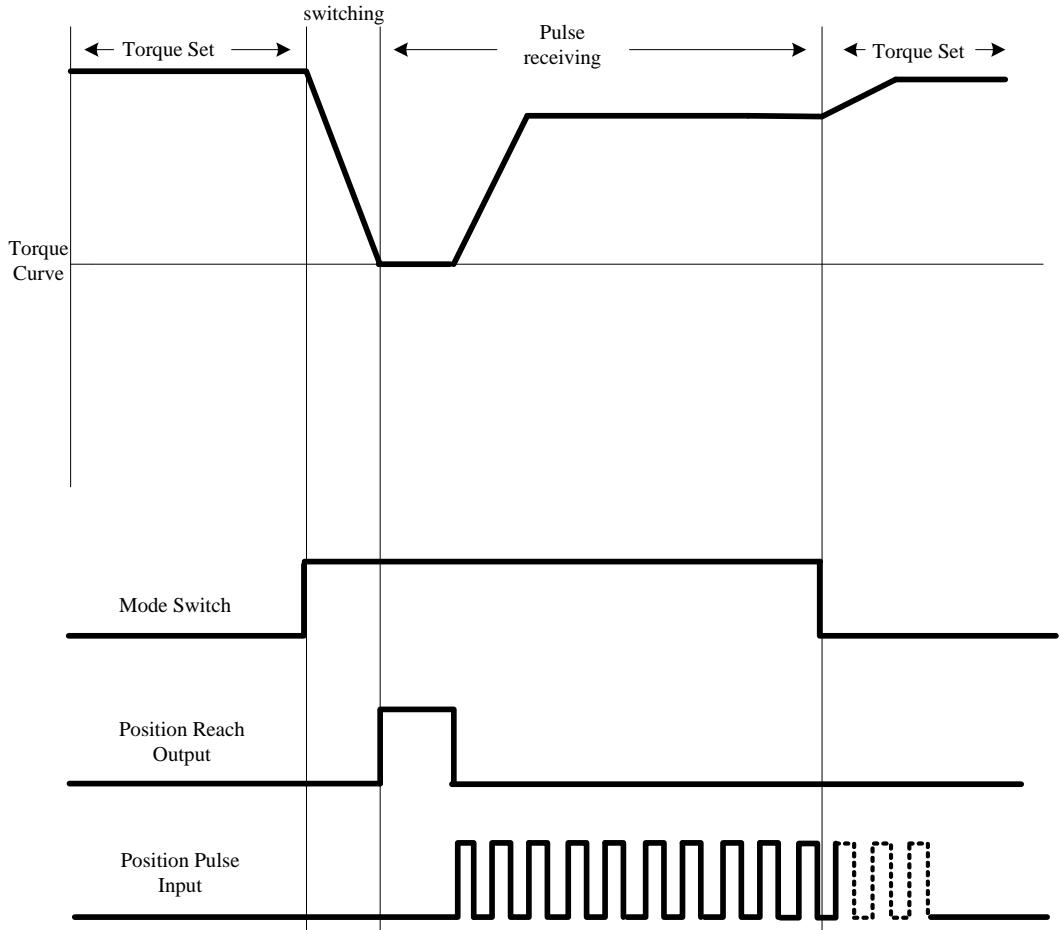

Fig 6.5.5 Torque mode and position pulse mode sequence diagram

6.5.7 Torque Mode and Internal Register Position Dual Mode

Internal register torque and position switching mode, external analog torque and internal register position switching mode show as figure 6.5.6, after servo is enabled, servo runs as internal register position mode when mode switching signal is enabled; servo runs as torque mode when mode switching signal is disabled.

In the running process of torque mode, servo slows down to zero according to deceleration time when mode switching signal is enabled; Servo cannot receive internal register position trigger signal until switching to internal register position mode after position reach signal output is enabled.

In the running process of internal register position mode, when mode switching signal is disabled, servo switches to torque mode Immediate and run to target torque according to acceleration and deceleration

time.

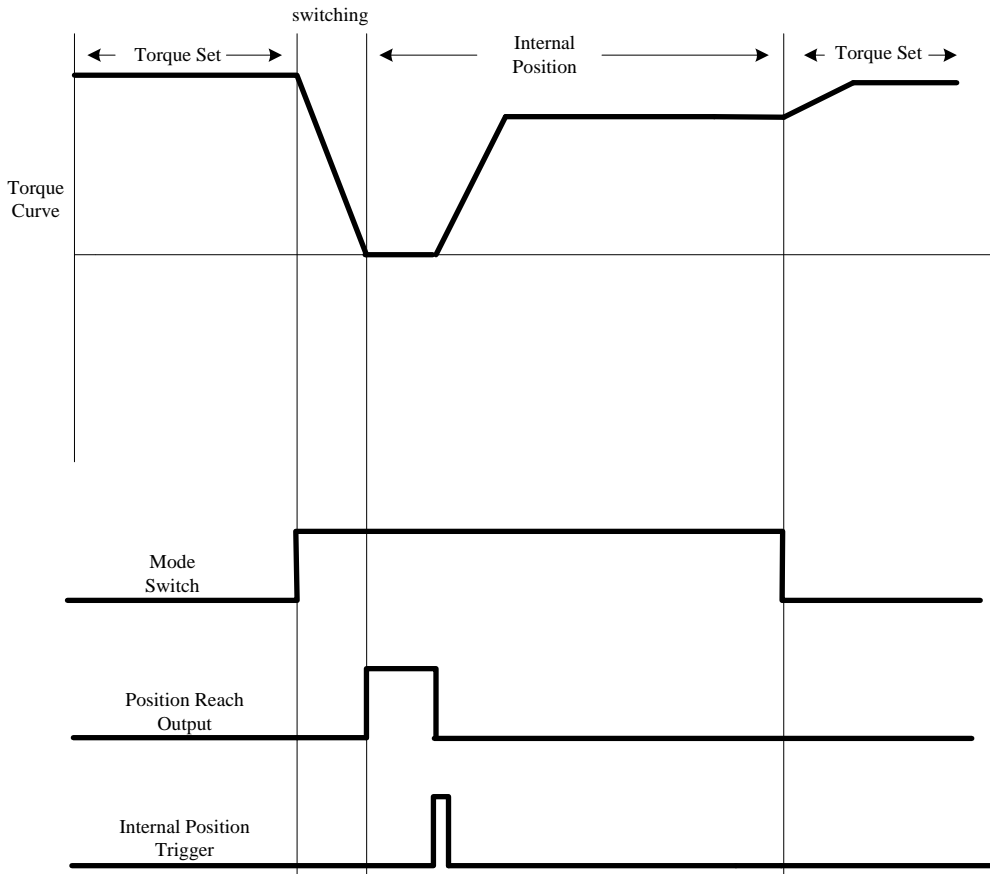

Fig 6.5.6 Torque mode and internal register position mode sequence diagram

6.5.8 Position Pulse and Internal Register Position Dual Mode

Position pulse command and internal register position switching mode shows as figure 6.5.7, after servo is enabled, servo runs as internal register mode when mode switching signal is enabled; Servo runs as position pulse mode when mode switching signal is disabled.

In the running process of position pulse mode, when mode switching signal is enabled, servo can receive internal position trigger only when position reach output signal is enabled.

In the running process of internal register position mode, when mode switching signal is disabled, servo can receive position pulse signal only when position reach output is enabled.

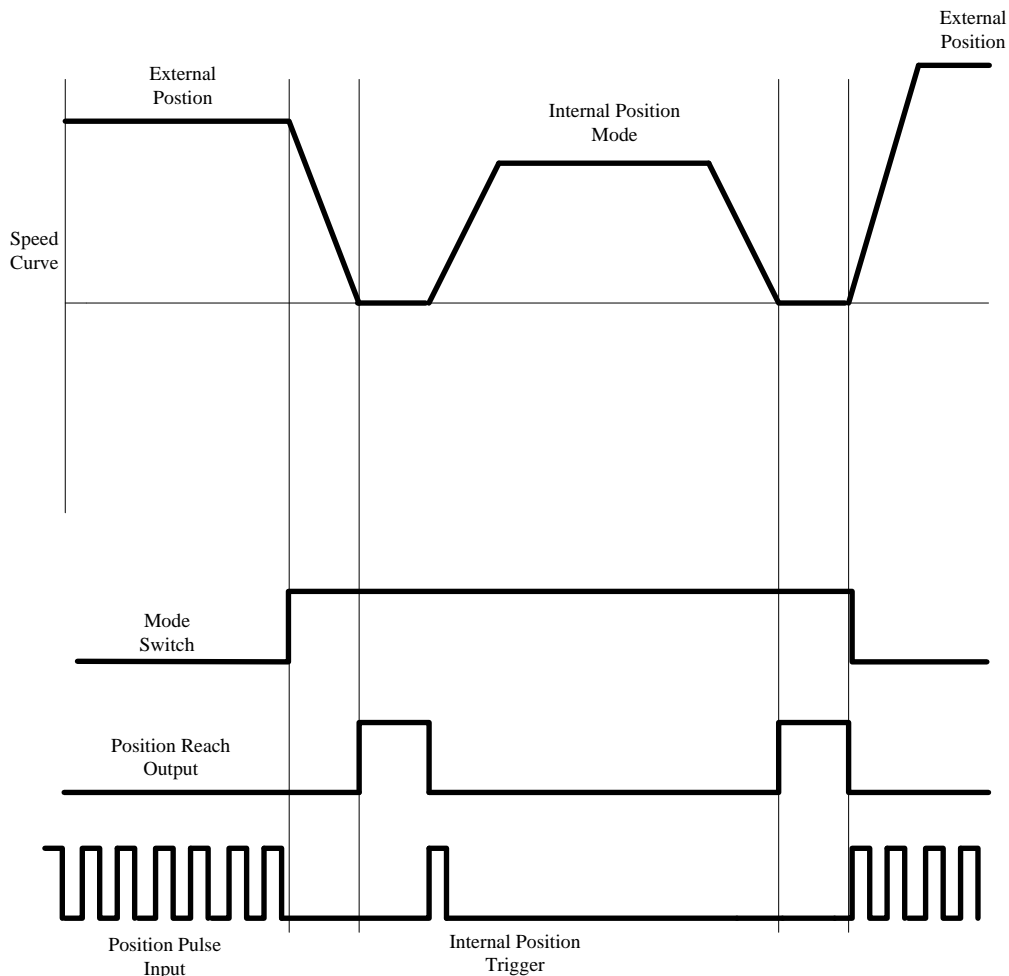

Fig 6.5.7 External position and internal position mode sequence diagram

6.5.9 Internal Speed and Analog Speed Dual Mode

Internal register speed and external analog speed switching mode shows as figure 6.5.8, after servo is enabled, servo runs as internal speed mode when internal speed selection signal is enabled; Servo runs as analog speed mode when internal speed selection signal is disabled.

In the running process of analog speed mode, when internal speed selection signal is enabled, servo switches to internal speed mode and run to internal setting speed according to acceleration/deceleration time.

In the running process of internal speed mode, when speed selection signal is disabled, servo switches to analog speed mode and run to analog setting speed according to acceleration/deceleration time.

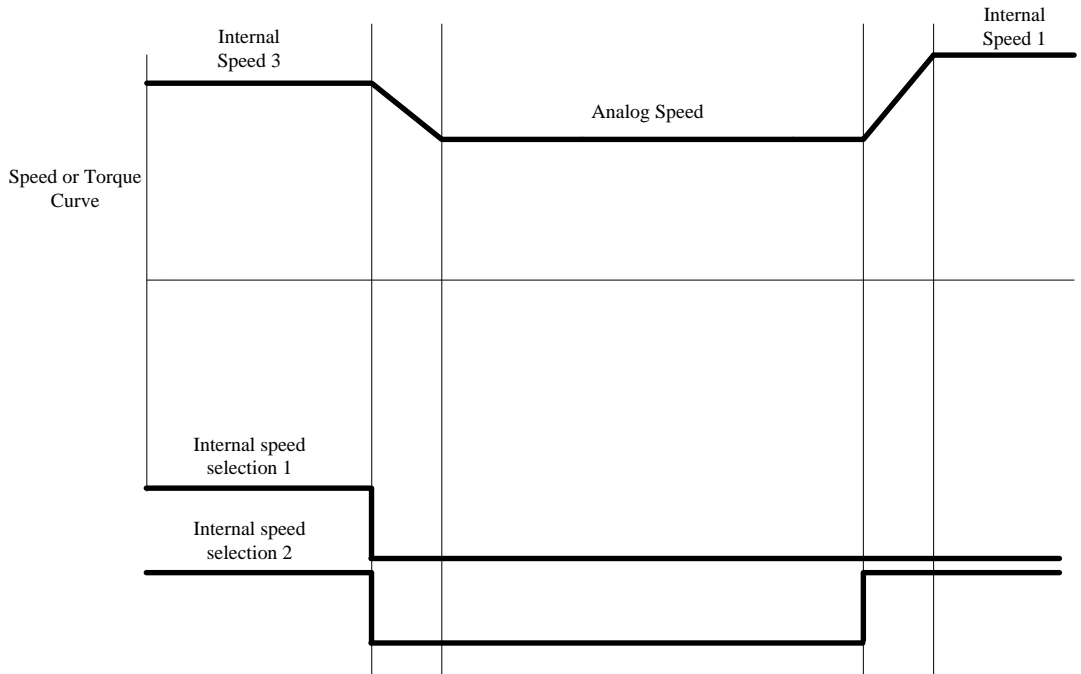

Fig 6.5.8 Analog speed and internal speed mode sequence diagram

6.5.10 Speed and Torque Dual Mode

(1) Internal register speed and torque switching mode, internal register speed and external analog torque switching mode show as figure 6.5.9, after servo is enabled, servo runs as speed mode when internal speed selection signal is enabled; servo runs as torque mode when internal speed selection signal is disabled.

In the running process of speed mode, servo switches to torque mode when speed selection signal is disabled, and run to setting torque according to deceleration time.

In the running process of torque mode, servo switches to speed mode when speed selection signal is enabled, and run to target speed according to acceleration/deceleration time.

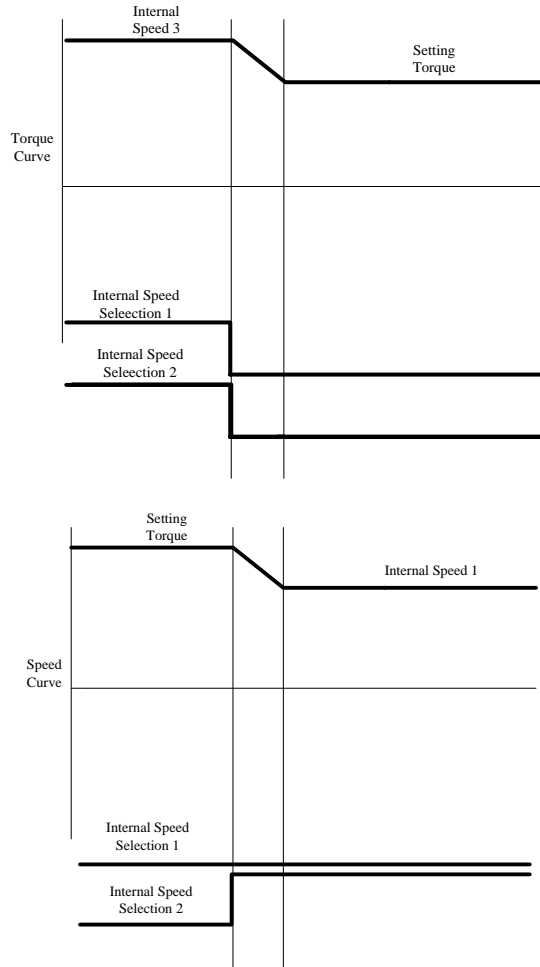

Fig 6.5.9 Speed mode and torque mode switching sequence diagram

(2) External analog speed and internal register torque switching mode, external analog speed and torque switching mode show as figure 6.5.10, after servo is enabled, servo runs as torque mode when mode switching signal is enabled; Servo runs as speed mode when mode switching signal is disabled.

In the running process of speed mode, servo switches to torque mode when mode selection signal is enabled, and run to setting torque according to deceleration time.

In the running process of torque mode, servo switches to speed mode when mode selection signal is disabled, and run to target speed according to acceleration/deceleration time.

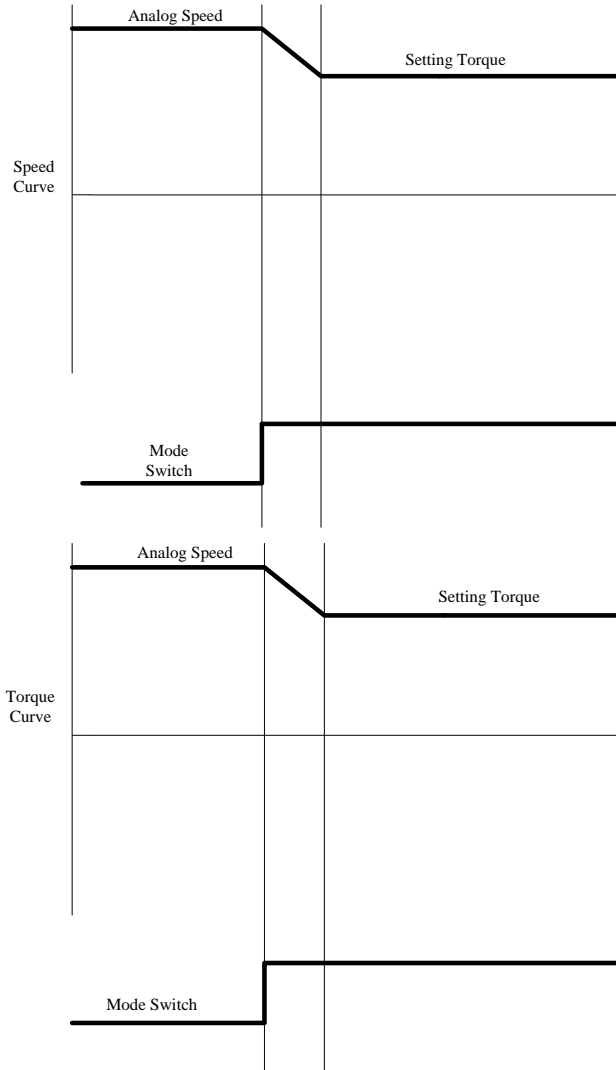

Fig 6.5.10 Speed mode and torque mode switching sequenc diagram

6.5.11 Analog Torque and Internal Register Torque Dual Mode

Internal register torque and external analog torque switching mode shows as figure 6.5.11, after servo is enabled, servo runs as internal register torque mode when mode switching signal is enabled; Servo runs as analog torque mode when mode switching signal is disabled.

In the running process of analog torque mode, servo switches to internal register torque mode when mode switching signal is enabled and run to internal setting torque according to acceleration/deceleration time.

In the running process of internal register torque mode, when mode switching signal is disabled, servo switches to analog torque mode and run to analog setting torque according to acceleration/deceleration time.

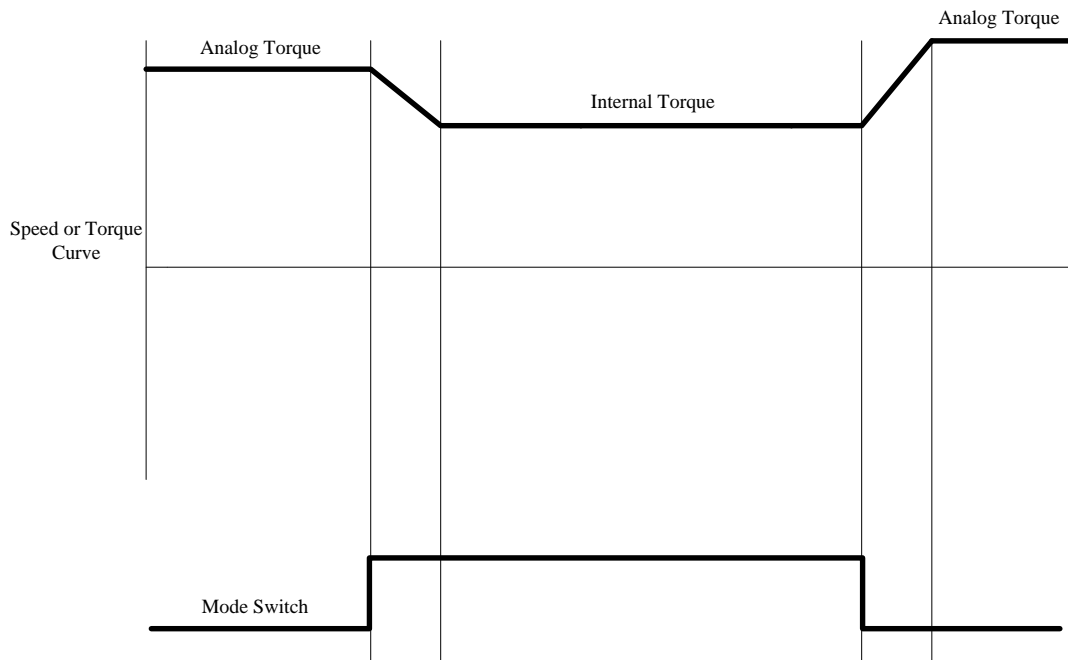

Fig 6.5.11 Analog torque and internal torque mode switching sequence diagram

6.6 Auxiliary Function

Servo drives supply auxiliary function in order to make sure system work correctly.

6.6.1 Setting password

So-01	Setting password speed position torque			
	(Avoid modifying parameters by mistake)			
	Setting range	Setting unit	Mfr's value	When enabled
	0~9999	N/A	0	restart

Setting password is used to avoid modifying parameters by mistake. The mfr's value is 0, which means password is invalid and users can modify parameters anytime. If users want to use this function, please set a password for this parameter and restart servo, then this function is valid.

Most auxiliary function and main function parameters except monitor function parameters can be

modified when the password is input into this parameter. Or else Err will display.

6.6.2 Servo drive status display

So-09	Servo drive status display			
			<input type="checkbox"/> speed	<input type="checkbox"/> position <input type="checkbox"/> torque
	Setting range	Setting unit	Mfr's value	When enabled
	0~37	N/A	2	Effective Immediately

This parameter is used to set default display content in keypad. Please refer to next table about the display item:

Setting value	Definition	Setting value	Definition
0	Servo drive output current	19	Rotating inertia display
1	Servo drive bus voltage	20	Output torque display
2	Servo motor rotating speed	21	Current gain group
3	Servo motor feedback pulse displays high 5 digits.	22	Discharge time
4	Servo motor feedback pulse displays low 5 digits.	23	Encoder absolute position high digit pulse
5	Servo motor feedback rotation displays high 5 digits.	24	Encoder absolute position low digit pulse
6	Servo motor feedback rotation displays low 5 digits.	25	High 5 digits of number of turns of encoder absolute position
7	Given command pulse numbers display high 5 digits.	26	Low 5 digits of number of turns of encoder absolute position
8	Given command pulse numbers display low 5 digits.	27	AI1 voltage
9	Given command pulse error numbers	28	AI2 voltage
10	Given speed	29	Combined deviation
11	Given torque	30	Close-loop feedback
12	Analog speed command display	31	Gantry synchronous deviation
13	Analog torque command display	32	Reserved
14	D18~D15 status display	33	Hight- speed counter 1
15	D14~D11 status display	34	Hight- speed counter 2
16	Other output interface status display	35	PLC monitor
17	D4~D1 status display	36	Motor temperature
18	Drive current temperature display	37	Motor shaft position

6.6.3 Fan setting

So-26	Fan control <input type="checkbox"/> speed <input type="checkbox"/> position <input type="checkbox"/> torque			
	Setting range	Setting unit	Mfr's value	When enabled
	0~2	N/A	2	Effective Immediately
	0: Fan is controlled by temperature. 1: Fan will run after power on. 2: Fan will run when servo drive starts running.			

When So-26=0, and when radiator temperature reaches to setting temperature, fan starts running. When radiator temperature is lower than So-27-5°, fan will stop running.

When So-26=2, fan will run when servo ON or temperature is higher than 45°. When servo off and radiator temperature is lower than 40°, fan will stop running after 500ms.

So-27	Fan temperature setting <input type="checkbox"/> speed <input type="checkbox"/> position <input type="checkbox"/> torque			
	Setting range	Setting unit	Mfr's value	When enabled
	10~100	°C	45	Effective Immediately

6.6.4 Parameter copy

So-44	Parameter copy <input type="checkbox"/> speed <input type="checkbox"/> position <input type="checkbox"/> torque																																
	Setting range	Setting unit	Mfr's value	When enabled																													
	Four-parameter	N/A	0000	Effective Immediately																													
	<p style="margin-left: 40px;"> b <input type="checkbox"/> <input type="checkbox"/> <input type="checkbox"/> <input type="checkbox"/> </p> <table style="margin-left: 100px; border-collapse: collapse;"> <tr> <td style="border: 1px solid black; padding: 2px;">A</td> <td style="border: 1px solid black; padding: 2px;">Copy function</td> </tr> <tr> <td style="border: 1px solid black; padding: 2px;">0</td> <td style="border: 1px solid black; padding: 2px;">Invalid</td> </tr> <tr> <td style="border: 1px solid black; padding: 2px;">1</td> <td style="border: 1px solid black; padding: 2px;">Valid</td> </tr> <tr> <td colspan="2" style="padding: 5px 0 5px 20px;"> </td> </tr> <tr> <td style="border: 1px solid black; padding: 2px;">B</td> <td style="border: 1px solid black; padding: 2px;">Copy motor parameters</td> </tr> <tr> <td style="border: 1px solid black; padding: 2px;">0</td> <td style="border: 1px solid black; padding: 2px;">Invalid</td> </tr> <tr> <td style="border: 1px solid black; padding: 2px;">1</td> <td style="border: 1px solid black; padding: 2px;">Valid</td> </tr> <tr> <td colspan="2" style="padding: 5px 0 5px 20px;"> </td> </tr> <tr> <td style="border: 1px solid black; padding: 2px;">C</td> <td style="border: 1px solid black; padding: 2px;">Copy gain parameters</td> </tr> <tr> <td style="border: 1px solid black; padding: 2px;">0</td> <td style="border: 1px solid black; padding: 2px;">Invalid</td> </tr> <tr> <td style="border: 1px solid black; padding: 2px;">1</td> <td style="border: 1px solid black; padding: 2px;">Valid</td> </tr> <tr> <td colspan="2" style="padding: 5px 0 5px 20px;"> </td> </tr> <tr> <td style="border: 1px solid black; padding: 2px;">D</td> <td style="border: 1px solid black; padding: 2px;">Copy notch filter parameters</td> </tr> <tr> <td style="border: 1px solid black; padding: 2px;">0</td> <td style="border: 1px solid black; padding: 2px;">Invalid</td> </tr> <tr> <td style="border: 1px solid black; padding: 2px;">1</td> <td style="border: 1px solid black; padding: 2px;">Valid</td> </tr> </table>				A	Copy function	0	Invalid	1	Valid			B	Copy motor parameters	0	Invalid	1	Valid			C	Copy gain parameters	0	Invalid	1	Valid			D	Copy notch filter parameters	0	Invalid	1
A	Copy function																																
0	Invalid																																
1	Valid																																
B	Copy motor parameters																																
0	Invalid																																
1	Valid																																
C	Copy gain parameters																																
0	Invalid																																
1	Valid																																
D	Copy notch filter parameters																																
0	Invalid																																
1	Valid																																

6.6.5 Reverting to Mfr's Value

When there is disorder with parameters and mfr's value need to restored, set So-49=1.

Related Parameters

So-49	Reverting to Mfr's value speed position torque			
	Setting Range	Setting Unit	Mfr's Value	Effect
	0~1	N/A	0	Restart

The procedure is that set So-49=1 and holding prees SET key for 0.5s, "00000" is displayed. After 5 seconds, all parameters revert to mfr's value automatically.

6.6.6 Motor Protection Function

(1) Motor Overload Protection

When there is output for servo motor, output current continuously generates heat, and releases heat into surrounding environment, when the generated heat goes over than released heat, the rising temperature of motor is so high that make the motor excitation-loss and damage, and therefore, servo drive provides motor overload protection function to prevent the damage from excessive temperature.

Set motor overload protection (So-37) to adjust the time of motor overload fault (AL-06). Generally, So-37 remains default value, but if the following situation happens, So-37 can be modified according to motor actual heat situation:

- The occasion of higher operating ambient temperature for servo motor;
- The occasion that servo motor runs circularly, one-time motion period is short and frequent switching;

(1) Related Parameter

So-37	Motor overload coefficient setting speed position torque			
	Setting Range	Setting Unit	Mfr's Value	Effect
	0~500	%	100	Effective Immediately

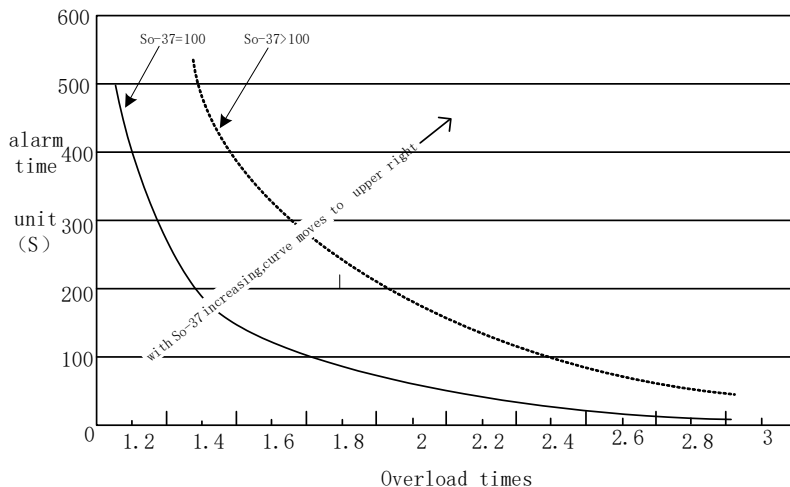

Fig 6.6.1 Motor overload curve and alarm time curve graph

(2) Motor lock-rotor protection

Motor speed is almost 0 when servo-motor lock-rotor occurs, but the actual current is very high, servo drive and servo motor may be damaged because of long time lock-rotor, therefore, servo drive provides the motor lock-rotor protection to prevent the damage from excessive temperature in the situation of motor lock-rotor.

Related Parameter

So-34	Motor lock-rotor protection [speed] [position] [torque]			
	Setting Range	Setting Unit	Mfr's Value	Effect
	0~1	N/A	1	Effective Immediately
So-40	Delay time of lock-rotor protection [speed] [position] [torque]			
	Setting Range	Setting Unit	Mfr's Value	Effect
	10~1000	10ms	50	Effective Immediately

(3) Motor overheat protection

So-50	Motor overheat protection [speed] [position] [torque]			
	Setting range	Setting unit	Mfr's value	When enabled
	0~1	N/A	0	Effective Immediately
	0: Invalid 1: Valid			

So-51	Temperature detection disconnection protection			speed	position	torque
	Setting range	Setting unit	Mfr's value	When enabled		
	0~1	N/A	1	Effective Immediately		
	0: Invalid 1: Valid					

6.6.7 Encoder pulse filtering

So-52	Encoder pulse filtering coefficient			speed	position	torque
	Setting range	Setting unit	Mfr's value	When enabled		
	0~1000	N/A	0	Effective Immediately		
	When So-52≠0, the signal level which duration time is lower than (So-52/30MHz)s will be filtered.					

6.6.8 Torque unreached protection control

When output torque can not reach given torque, keypad may display protection code 'AL-23' by setting following parameters.

So-54	Torque unreached protection setting			speed	position	torque
	Setting range	Setting unit	Mfr's value	When enabled		
	0~1	N/A	1	Effective Immediately		

0: invalid 1: valid

So-55	Torque unreached time			speed	position	torque
	Setting range	Setting unit	Mfr's value	When enabled		
	1~100	10ms	10	Effective Immediately		

After unreached torque keeps time of So-55, servo drive trips into AL-23.

6.6.9 DI Terminals Filter Function

Servo drive have 8 DI terminals, DI1~DI8 is normal DI terminal.

Normal DI terminal filter setting

If there is interference in terminal signal, users can carry on filter processing by setting Po438~Po444.

Po438	DI1 filter time			speed	position	torque
	Setting Range	Setting Unit	Mfr's Value	Effect		
	0~30000	N/A	2	Effective Immediately		

FL20-SA Series

Po439	DI2 filter time speed position torque			
	Setting Range	Setting Unit	Mfr's Value	Effect
	0~30000	N/A	2	Effective Immediately
Po440	DI3 filter time speed position torque			
	Setting Range	Setting Unit	Mfr's Value	Effect
	0~30000	N/A	2	Effective Immediately
Po441	DI4 filter time speed position torque			
	Setting Range	Setting Unit	Mfr's Value	Effect
	0~30000	N/A	2	Effective Immediately
Po442	DI5 filter time speed position torque			
	Setting Range	Setting Unit	Mfr's Value	Effect
	0~30000	N/A	2	Effective Immediately
Po443	DI6 filter time speed position torque			
	Setting Range	Setting Unit	Mfr's Value	Effect
	0~30000	N/A	2	Effective Immediately
Po444	DI7 filter time speed position torque			
	Setting Range	Setting Unit	Mfr's Value	Effect
	0~30000	N/A	2	Effective Immediately
Po445	DI8 filter time speed position torque			
	Setting Range	Setting Unit	Mfr's Value	Effect
	0~30000	N/A	2	Effective Immediately

6.6.10 Cogging torque compensation

Cogging torque is the torque due to the interaction between permanent magnets of rotor and the stator slots when the motor is not connected with power supply.

The cogging torque will cause vibration and noise of motor, speed fluctuation, unstable running.

When torque's ripple frequency matches with the rator or stator's resonate frequency, the vibieration and noise caused by cogging torque will be enlarged more. This function could decrease the influence of cogging torque and improve the torque performance.

So-25	Motor parameter identification speed position torque			
	Setting Range	Setting Unit	Mfr's Value	Effect
	0~10	N/A	0	Effective Immediately
When So-25=9, the drive enables autotuning of cogging torque. Please make sure that the				

	motor is without load. Note: When autotuning is enable, the screen will display “TEST”, which will last for 1-2 seconds. Please do not touch the motor shaft and keep the shaft without any load.			
Po289	Enable cogging torque compensation			<input type="checkbox"/> speed <input type="checkbox"/> position <input type="checkbox"/> torque
	Setting Range	Setting Unit	Mfr's Value	Effect
	0~1	N/A	0	Re-power on
	0: disable 1: enable			

6.6.11 Friction torque compensation

The motor shaft will have friction during running, which will influence the control accuracy, even will cause shock. The function will compensate the friction torque, reduce the impact of friction torque, improve the performance. There will be three internal compensating point. The compensation is linear among the three point. The set step is as below.

- (1) Check the motor's rated speed
- (2) According to the actual working speed, set Po290, Po292, Po294
 - <1> Po290, Po292, Po294 is the percentage between the actual working speed and motor's rated speed,
 - <2> Po290, Po292, Po294 is aimed to the low, middle, high speed range. Customer could set it according to their actual requirement. For a easy way, customer could use the default value to make autotuning.
- (3) Set So-25=10, make autotuning of friction torque compensation
- (4) Autotuning finish.

Note:

1. The three reference(Po290, Po292, Po294) is very important. All three parameter should be set according to customer's requirement by autotuning.
2. Po291, Po293, Po295 is the percentage between the present output torque and motor's rated torque. If customer want to manually input Po291, Po293, Po295, they can refer to the below two method.
 - (1) Refer to the monitoring torque value by PC software,
 - (2) Refer to Lo-20, which is the percentage between the present output torque and motor's rated torque.
3. After autotuning of friction torque, the percentage between the present output torque and rated torque has been automatically stored in Po291, Po293, Po295. If customer has not special requirement, the autotuning result is good enough for friction torque compensation.

FL20-SA Series

So-25	Motor parameter identification			speed position torque
	Setting Range	Setting Unit	Mfr's Value	Effect
	0~10	N/A	0	Effective Immediately
	When So-25=10, make autotuning of friction torque compensation, please make sure the motor is without load. Note: When autotuning is enable, the screen will display "TEST". The motor will run forward and backward for three times. The speed of three times will be according to Po290, Po292, Po294.			

Po290	Friction compensation speed 1			speed position torque
	Setting Range	Setting Unit	Mfr's Value	Effect
	0~100	0.1%	10	Effective Immediately
Po291	Friction compensation coefficient 1			speed position torque
	Setting Range	Setting Unit	Mfr's Value	Effect
	0~100	0.1%	0	Effective Immediately
Po292	Friction compensation speed 2			speed position torque
	Setting Range	Setting Unit	Mfr's Value	Effect
	100~300	0.1%	100	Effective Immediately
Po293	Friction compensation coefficient 2			speed position torque
	Setting Range	Setting Unit	Mfr's Value	Effect
	0~100	0.1%	0	Effective Immediately
Po294	Friction compensation speed 3			speed position torque
	Setting Range	Setting Unit	Mfr's Value	Effect
	300~1000	0.1%	300	Effective Immediately
Po295	Friction compensation coefficient 3			speed position torque
	Setting Range	Setting Unit	Mfr's Value	Effect
	0~100	0.1%	0	Effective Immediately

6.6.12 Other Output Signals

(1) Servo Alarm Terminal Output

ALM is activated when the servo drive has detected a fault condition. ON signal is output when servo works well, OFF signal is output when there is a malfunction.

FL20-SA Series

Signal Name	Name	Terminals	Remarks
Servo Alarm Output	ALM	ALM- ALM+	Servo alarm output signal, can provide failure indication

(2) Servo Ready Output

Signal Name	Name	Terminals	Remarks
SRDY	SRDY	SRDY+	Servo ready output
		SRDY-	

Output ON means that the servo drive is ready to receive signal, control circuit and main circuit power supply are normal, there is no servo alarms. Output OFF means that servo drive is not ready.

(3) Overload pre-alarm signal output

When servo output current reaches or exceeds overload pre-alarm current, and after overload pre-alarm filter time, the output current still reaches or higher than pre-alarm current, then this signal is output.

Signal Name	Default terminal	Remarks
OL-W	Allocated by users	Pre-alarm signal of overload

Related parameters:

So-35	Overload pre-alarm current <input type="checkbox"/> speed <input type="checkbox"/> position <input type="checkbox"/> torque			
	Setting Range	Setting Unit	Mfr's Value	Effect
	0~800	%	120	Effective Immediately
So-36	Overload pre-alarm filter time <input type="checkbox"/> speed <input type="checkbox"/> position <input type="checkbox"/> torque			
	Setting Range	Setting Unit	Mfr's Value	Effect
	0~1000	10ms	10	Effective Immediately

(4) Signal output in speed limit

When rotate speed is limited, DO outputs this signal, and not related to motor rotation but valid for forward/reverse. It should allocate 1 DO terminal (speed limiting) to servo drive and set DO terminal logic.

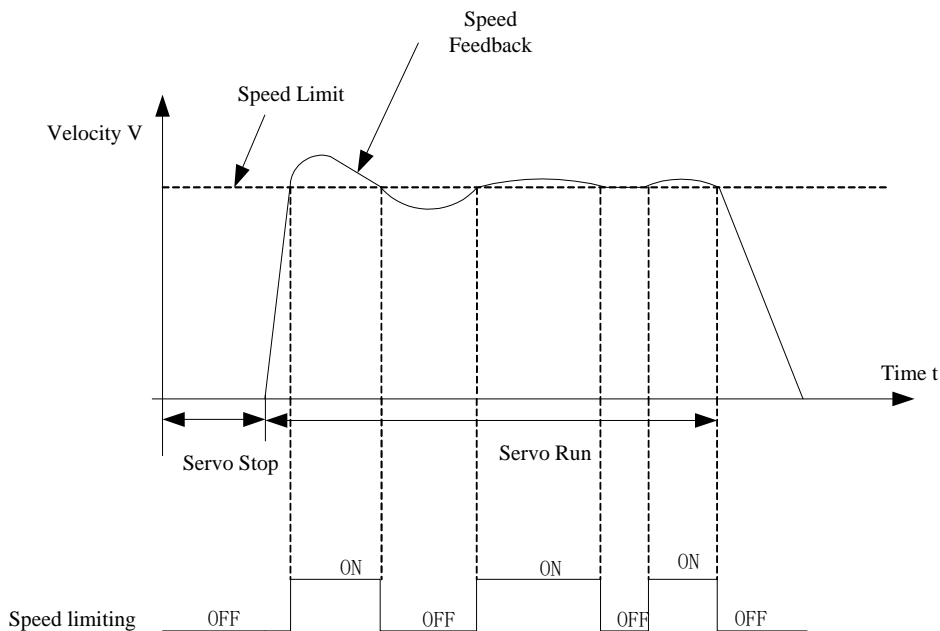

Fig 6.6.3 Output in speed limit under torque mode sketch map

6.7 High-Speed Counter Function

6.7.1 Overview

High-speed counter is the specific function of FL20 series. It is convenient for user to set external command processing mode and control servo system.

High-speed counter integrates the function of data capture, which is using external or internal trigger signal to capture the position data of motion axis instantaneously, and store to data array for the use of the follow-up motion control.

High-speed counter is applied mostly in full closed-loop, electronic cam, built-in PLC and pulse command function. It is more convenient to process external data and more efficient to execute instructions.

High-speed counter integrates 2 groups of counters, which can be set by user according to different demands.

6.7.2 High-Speed Counting

High-speed counter internal frame diagram shows as below:

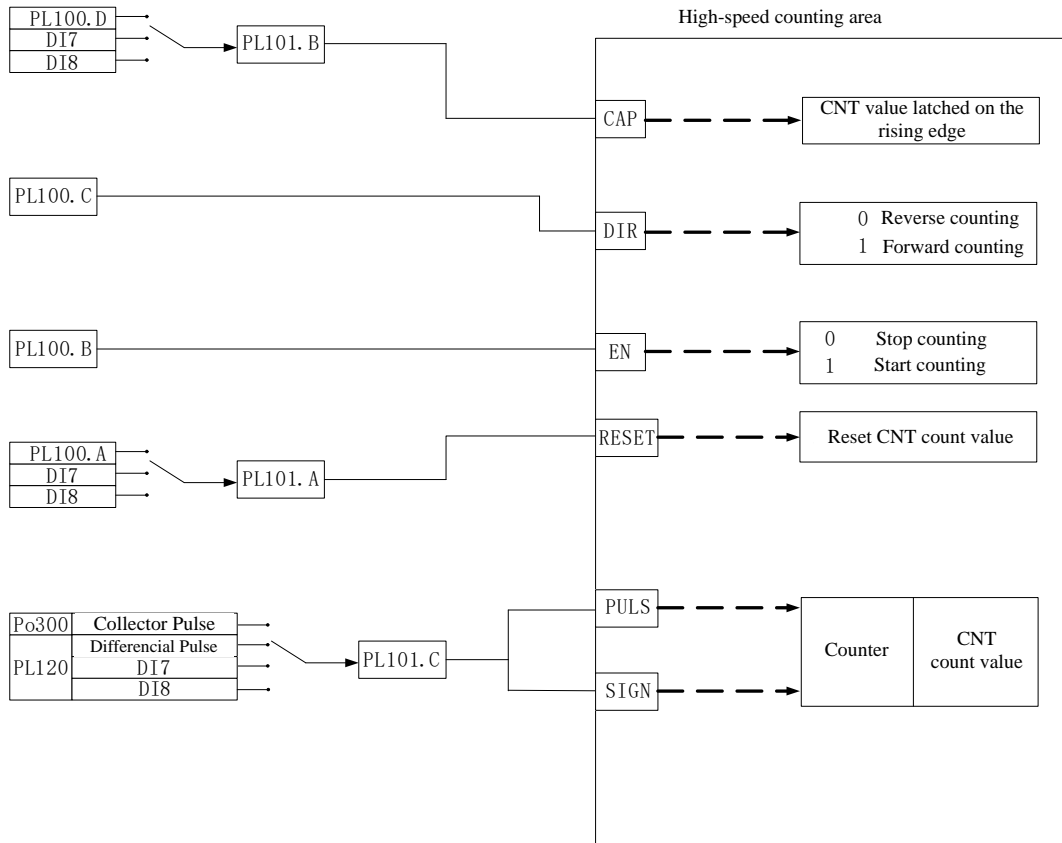

Fig 6.7.1 High-speed counter internal frame diagram

Note: DI7, DI8 support Max frequency 3KHz.

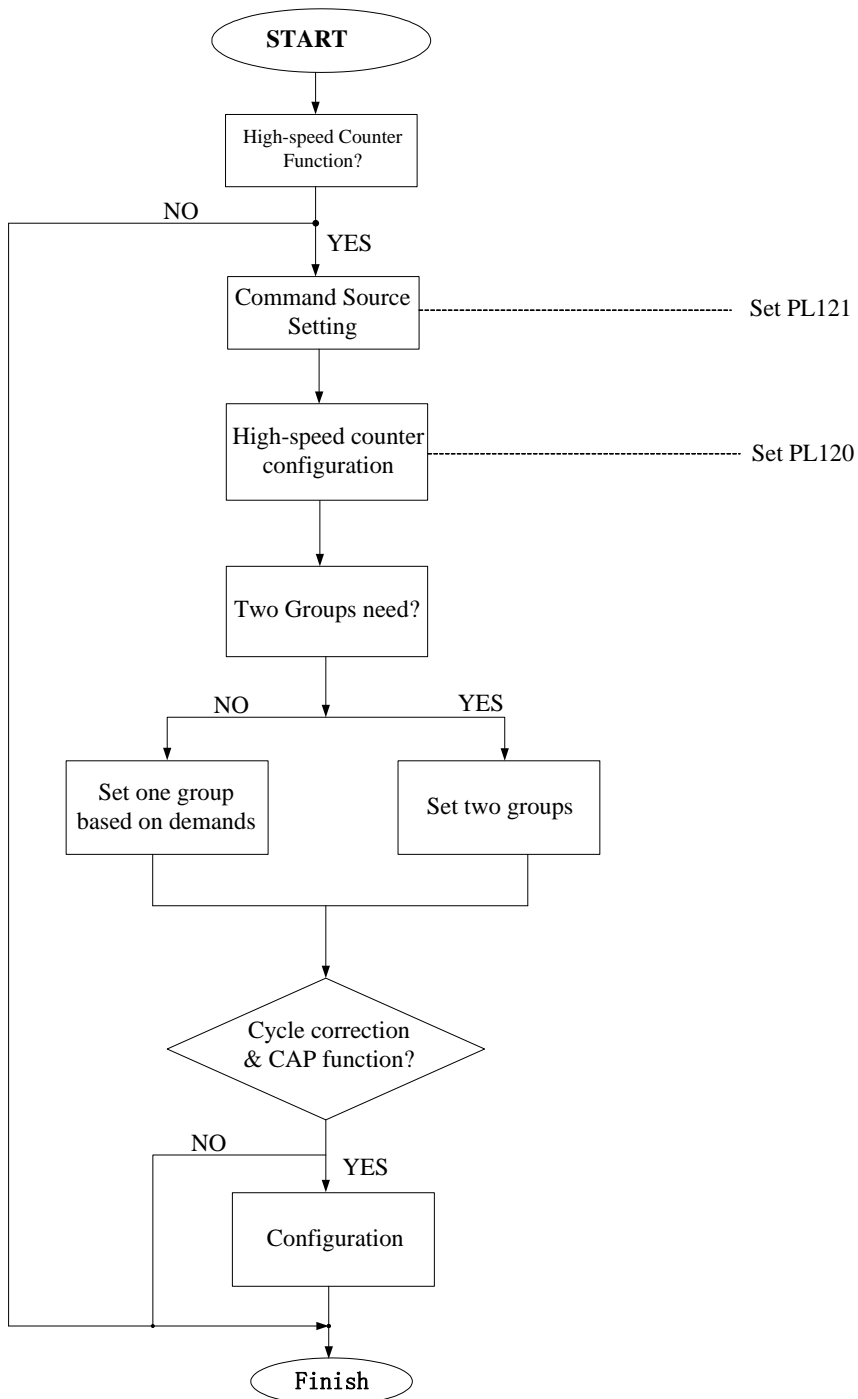

Fig 6.7.2 High-speed counter setting flow chart

(1) User Parameter

1) Set command source of high-speed counting command source

PL121	Internal command source			speed	position	torque
	Setting Range	Setting Unit	Mfr's Value	Effect		
	0~1	N/A	0	Effective Immediately		
	0: Internal parameter PL100 1: Internal PLC					

2) Configuration of high-speed counter

PL120	High-speed counter setting			speed	position	torque																																																							
	Setting Range	Setting Unit	Mfr's Value	Effect																																																									
	Four-parameter	N/A	0000	Effective Immediately																																																									
	<table border="1" style="margin-left: 20px;"> <tr> <td>A</td> <td>High - speed pulse type</td> </tr> <tr> <td>0</td> <td>Direction + Pulse</td> </tr> <tr> <td>1</td> <td>Dipulse</td> </tr> <tr> <td>2</td> <td>Orthogonal pulse</td> </tr> <tr> <td>B</td> <td>High-speed pulse filtering</td> </tr> <tr> <td>0</td> <td>8MHz</td> </tr> <tr> <td>1</td> <td>4MHz</td> </tr> <tr> <td>2</td> <td>2MHz</td> </tr> <tr> <td>3</td> <td>1MHz</td> </tr> <tr> <td>4</td> <td>500KHz</td> </tr> <tr> <td>5</td> <td>200KHz</td> </tr> <tr> <td>6</td> <td>150KHz</td> </tr> <tr> <td>C</td> <td>High-speed pulse direction</td> </tr> <tr> <td>0</td> <td>HPULS anti-logic, HSIGN anti-logic</td> </tr> <tr> <td>1</td> <td>HPULS positive logic, HSIGN positive logic</td> </tr> <tr> <td>2</td> <td>HPULS anti-logic, HSIGN positive logic</td> </tr> <tr> <td>3</td> <td>HPULS positive logic, HSIGN anti-logic</td> </tr> <tr> <td>4</td> <td>Exchange HPULS and HSIGN</td> </tr> <tr> <td>D</td> <td>DI7/DI8 filter time</td> </tr> <tr> <td>0</td> <td>800KHz</td> </tr> <tr> <td>1</td> <td>400KHz</td> </tr> <tr> <td>2</td> <td>200KHz</td> </tr> <tr> <td>3</td> <td>100KHz</td> </tr> <tr> <td>4</td> <td>40KHz</td> </tr> <tr> <td>5</td> <td>30KHz</td> </tr> <tr> <td>6</td> <td>16KHz</td> </tr> <tr> <td>7</td> <td>8 KHz</td> </tr> <tr> <td>8</td> <td>4 KHz</td> </tr> </table>						A	High - speed pulse type	0	Direction + Pulse	1	Dipulse	2	Orthogonal pulse	B	High-speed pulse filtering	0	8MHz	1	4MHz	2	2MHz	3	1MHz	4	500KHz	5	200KHz	6	150KHz	C	High-speed pulse direction	0	HPULS anti-logic, HSIGN anti-logic	1	HPULS positive logic, HSIGN positive logic	2	HPULS anti-logic, HSIGN positive logic	3	HPULS positive logic, HSIGN anti-logic	4	Exchange HPULS and HSIGN	D	DI7/DI8 filter time	0	800KHz	1	400KHz	2	200KHz	3	100KHz	4	40KHz	5	30KHz	6	16KHz	7	8 KHz	8
A	High - speed pulse type																																																												
0	Direction + Pulse																																																												
1	Dipulse																																																												
2	Orthogonal pulse																																																												
B	High-speed pulse filtering																																																												
0	8MHz																																																												
1	4MHz																																																												
2	2MHz																																																												
3	1MHz																																																												
4	500KHz																																																												
5	200KHz																																																												
6	150KHz																																																												
C	High-speed pulse direction																																																												
0	HPULS anti-logic, HSIGN anti-logic																																																												
1	HPULS positive logic, HSIGN positive logic																																																												
2	HPULS anti-logic, HSIGN positive logic																																																												
3	HPULS positive logic, HSIGN anti-logic																																																												
4	Exchange HPULS and HSIGN																																																												
D	DI7/DI8 filter time																																																												
0	800KHz																																																												
1	400KHz																																																												
2	200KHz																																																												
3	100KHz																																																												
4	40KHz																																																												
5	30KHz																																																												
6	16KHz																																																												
7	8 KHz																																																												
8	4 KHz																																																												

3) Set two gourps of high-speed counter function

PL100	High-speed counter 1 control command			speed	position	torque
	Setting Range	Setting Unit	Mfr's Value	Effect		
	Four-parameter	N/A	0010	Effective Immediately		

FL20-SA Series

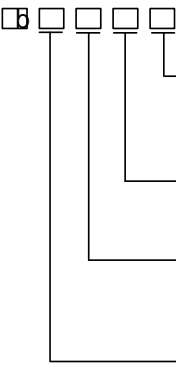
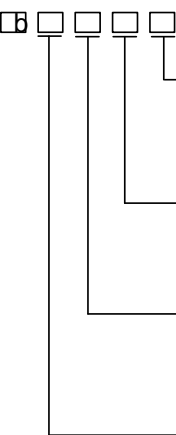
	 <table border="1" style="margin-left: auto; margin-right: auto;"> <tr><td>A</td><td>High-speed counter Reset</td></tr> <tr><td>0</td><td>No Reset</td></tr> <tr><td>1</td><td>Reset</td></tr> <tr><td colspan="2">B High-speed counter enabled</td></tr> <tr><td>0</td><td>Disabled</td></tr> <tr><td>1</td><td>Enabled</td></tr> <tr><td colspan="2">C High-speed counter direction</td></tr> <tr><td>0</td><td>Reverse</td></tr> <tr><td>1</td><td>Forward</td></tr> <tr><td colspan="2">D CAP enabled</td></tr> <tr><td>0</td><td>Close CAP function</td></tr> <tr><td>1</td><td>Open CAP function</td></tr> </table>	A	High-speed counter Reset	0	No Reset	1	Reset	B High-speed counter enabled		0	Disabled	1	Enabled	C High-speed counter direction		0	Reverse	1	Forward	D CAP enabled		0	Close CAP function	1	Open CAP function							
A	High-speed counter Reset																															
0	No Reset																															
1	Reset																															
B High-speed counter enabled																																
0	Disabled																															
1	Enabled																															
C High-speed counter direction																																
0	Reverse																															
1	Forward																															
D CAP enabled																																
0	Close CAP function																															
1	Open CAP function																															
PL101	High-speed counter 1 command source [speed] [position] [torque]																															
	<table border="1" style="width: 100%; border-collapse: collapse;"> <thead> <tr> <th>Setting Range</th> <th>Setting Unit</th> <th>Mfr's Value</th> <th>Effect</th> </tr> </thead> <tbody> <tr> <td>Four-parameter</td> <td>N/A</td> <td>0100</td> <td>Effective Immediately</td> </tr> </tbody> </table>	Setting Range	Setting Unit	Mfr's Value	Effect	Four-parameter	N/A	0100	Effective Immediately																							
	Setting Range	Setting Unit	Mfr's Value	Effect																												
	Four-parameter	N/A	0100	Effective Immediately																												
 <table border="1" style="margin-left: auto; margin-right: auto;"> <tr><td>A</td><td>Reset source setting</td></tr> <tr><td>0</td><td>Software</td></tr> <tr><td>1</td><td>DI8</td></tr> <tr><td>2</td><td>DI7</td></tr> <tr><td colspan="2">B CAP command source setting</td></tr> <tr><td>0</td><td>Software</td></tr> <tr><td>1</td><td>DI8</td></tr> <tr><td>2</td><td>DI7</td></tr> <tr><td colspan="2">C Command source setting</td></tr> <tr><td>0</td><td>Low-speed pulse</td></tr> <tr><td>1</td><td>High-speed pulse</td></tr> <tr><td>2</td><td>DI8</td></tr> <tr><td>3</td><td>DI7</td></tr> <tr><td colspan="2">D Duty-cycle correction mode</td></tr> <tr><td>0</td><td>Close</td></tr> <tr><td>1</td><td>Start</td></tr> </table>	A	Reset source setting	0	Software	1	DI8	2	DI7	B CAP command source setting		0	Software	1	DI8	2	DI7	C Command source setting		0	Low-speed pulse	1	High-speed pulse	2	DI8	3	DI7	D Duty-cycle correction mode		0	Close	1	Start
A	Reset source setting																															
0	Software																															
1	DI8																															
2	DI7																															
B CAP command source setting																																
0	Software																															
1	DI8																															
2	DI7																															
C Command source setting																																
0	Low-speed pulse																															
1	High-speed pulse																															
2	DI8																															
3	DI7																															
D Duty-cycle correction mode																																
0	Close																															
1	Start																															
PL102	High-speed counter 1 compare register [speed] [position] [torque]																															
	<table border="1" style="width: 100%; border-collapse: collapse;"> <thead> <tr> <th>Setting Range</th> <th>Setting Unit</th> <th>Mfr's Value</th> <th>Effect</th> </tr> </thead> <tbody> <tr> <td>-2147483647~+2147483647</td> <td>N/A</td> <td>0</td> <td>Effective Immediately</td> </tr> </tbody> </table>	Setting Range	Setting Unit	Mfr's Value	Effect	-2147483647~+2147483647	N/A	0	Effective Immediately																							
	Setting Range	Setting Unit	Mfr's Value	Effect																												
-2147483647~+2147483647	N/A	0	Effective Immediately																													
PL104	High-speed counter 1 periodic value [speed] [position] [torque]																															
	<table border="1" style="width: 100%; border-collapse: collapse;"> <thead> <tr> <th>Setting Range</th> <th>Setting Unit</th> <th>Mfr's Value</th> <th>Effect</th> </tr> </thead> <tbody> <tr> <td>-2147483647~+2147483647</td> <td>N/A</td> <td>0</td> <td>Effective Immediately</td> </tr> </tbody> </table>	Setting Range	Setting Unit	Mfr's Value	Effect	-2147483647~+2147483647	N/A	0	Effective Immediately																							
	Setting Range	Setting Unit	Mfr's Value	Effect																												
-2147483647~+2147483647	N/A	0	Effective Immediately																													
PL106	High-speed counter 1 count value [speed] [position] [torque]																															
	<table border="1" style="width: 100%; border-collapse: collapse;"> <thead> <tr> <th>Setting Range</th> <th>Setting Unit</th> <th>Mfr's Value</th> <th>Effect</th> </tr> </thead> <tbody> <tr> <td>-2147483647~+2147483647</td> <td>N/A</td> <td>0</td> <td>Check</td> </tr> </tbody> </table>	Setting Range	Setting Unit	Mfr's Value	Effect	-2147483647~+2147483647	N/A	0	Check																							
	Setting Range	Setting Unit	Mfr's Value	Effect																												
-2147483647~+2147483647	N/A	0	Check																													

FL20-SA Series

PL108	High-speed counter1 CAP value			<u>speed</u>	<u>position</u>	<u>torque</u>																															
	Setting Range	Setting Unit	Mfr's Value	Effect																																	
	-2147483647~+2147483647	N/A	0	Check																																	
PL110	High-speed counter 2 control command			<u>speed</u>	<u>position</u>	<u>torque</u>																															
	Setting Range	Setting Unit	Mfr's Value	Effect																																	
	Four- parameter	N/A	0000	Effective Immediately																																	
	<table border="1"> <tbody> <tr> <td>A</td> <td>High-speed counter Reset</td> </tr> <tr> <td>0</td> <td>No Reset</td> </tr> <tr> <td>1</td> <td>Reset</td> </tr> <tr> <td>B</td> <td>High-speed counter enabled</td> </tr> <tr> <td>0</td> <td>Disabled</td> </tr> <tr> <td>1</td> <td>Enabled</td> </tr> <tr> <td>C</td> <td>High-speed counter direction</td> </tr> <tr> <td>0</td> <td>Reverse</td> </tr> <tr> <td>1</td> <td>Forward</td> </tr> <tr> <td>D</td> <td>CAP enabled</td> </tr> <tr> <td>0</td> <td>Close CAP function</td> </tr> <tr> <td>1</td> <td>Open CAP function</td> </tr> </tbody> </table>						A	High-speed counter Reset	0	No Reset	1	Reset	B	High-speed counter enabled	0	Disabled	1	Enabled	C	High-speed counter direction	0	Reverse	1	Forward	D	CAP enabled	0	Close CAP function	1	Open CAP function							
A	High-speed counter Reset																																				
0	No Reset																																				
1	Reset																																				
B	High-speed counter enabled																																				
0	Disabled																																				
1	Enabled																																				
C	High-speed counter direction																																				
0	Reverse																																				
1	Forward																																				
D	CAP enabled																																				
0	Close CAP function																																				
1	Open CAP function																																				
PL111	High-speed counter 2 command source			<u>speed</u>	<u>position</u>	<u>torque</u>																															
	Setting Range	Setting Unit	Mfr's Value	Effect																																	
	Four-parameter	N/A	0100	Effective Immediately																																	
	<table border="1"> <tbody> <tr> <td>A</td> <td>Reset source setting</td> </tr> <tr> <td>0</td> <td>Software</td> </tr> <tr> <td>1</td> <td>DI8</td> </tr> <tr> <td>2</td> <td>DI7</td> </tr> <tr> <td>B</td> <td>CAP command source setting</td> </tr> <tr> <td>0</td> <td>Software</td> </tr> <tr> <td>1</td> <td>DI8</td> </tr> <tr> <td>2</td> <td>DI7</td> </tr> <tr> <td>C</td> <td>Command source setting</td> </tr> <tr> <td>0</td> <td>Low-speed pulse</td> </tr> <tr> <td>1</td> <td>High-speed pulse</td> </tr> <tr> <td>2</td> <td>DI8</td> </tr> <tr> <td>3</td> <td>DI7</td> </tr> <tr> <td>D</td> <td>Duty-cycle correction mode</td> </tr> <tr> <td>0</td> <td>Close</td> </tr> <tr> <td>1</td> <td>Start</td> </tr> </tbody> </table>						A	Reset source setting	0	Software	1	DI8	2	DI7	B	CAP command source setting	0	Software	1	DI8	2	DI7	C	Command source setting	0	Low-speed pulse	1	High-speed pulse	2	DI8	3	DI7	D	Duty-cycle correction mode	0	Close	1
A	Reset source setting																																				
0	Software																																				
1	DI8																																				
2	DI7																																				
B	CAP command source setting																																				
0	Software																																				
1	DI8																																				
2	DI7																																				
C	Command source setting																																				
0	Low-speed pulse																																				
1	High-speed pulse																																				
2	DI8																																				
3	DI7																																				
D	Duty-cycle correction mode																																				
0	Close																																				
1	Start																																				
PL112	High-speed counter 2 compare register			<u>speed</u>	<u>position</u>	<u>torque</u>																															
	Setting Range	Setting Unit	Mfr's Value	Effect																																	
	-2147483647~+2147483647	N/A	0	Effective Immediately																																	

FL20-SA Series

PL114	High-speed counter 2 periodic value [speed] [position] [torque]			
	Setting Range	Setting Unit	Mfr's Value	Effect
	-2147483647~+2147483647	N/A	0	Effective Immediately
PL116	High-speed counter 2 count value [speed] [position] [torque]			
	Setting Range	Setting Unit	Mfr's Value	Effect
	-2147483647~+2147483647	N/A	0	Check
PL118	High-speed counter2 CAP value [speed] [position] [torque]			
	Setting Range	Setting Unit	Mfr's Value	Effect
	-2147483647~+2147483647	N/A	0	Check

When using the function of high-speed counter, set the pulse source according to PL101.C and PL111.C, servo drive starts to use different high-speed counter based on the setting of PL101.C and PL111.C. In the condition of correct external connection, the pulse received by servo drive will be displayed on the count value of the corresponding high-speed counter.

If using CAP function, servo drive stores the counter value into CAP value in the rising edge of CAP command, the source of CAP are software, DI7 and DI8, meanwhile user can set the periodic value (PL104&PL114) as required, servo drive latches pulses in the rising edge of CAP or setting period. When using the function of CAP period, since CAP happens in random time of pulse, servo drive will compare actual received pulse with the pulse captured from edge, then makes compensation to make the pulse count value equal to CAP value finally.

When using RESET function, servo drive will clear out the count value.

6.8 Built-in PLC Function

6.8.1 Summary

Servo built-in PLC function is a specific function of FL20 servo system, user can control servo drive by simple command, it is convenient for the use of special occasion.

FL20 built-in PLC can operate internal 8 DIs, 5 DOs, 2 groups of pulse receive, 1 group of pulse output, 2 analog inputs and 1 analog output. The program written by user is running in the servo software back-ground, every main cycle period runs 5 instructions continuously, in general, it runs 4000 commands for average 100ms, software can provide 4 low-speed timers, 2 high-speed counters and 2 high-speed timers.

When setting Po001 as d x 22, servo drive enters built-in PLC special control mode, the commands of position, speed and torque need to be set by built-in PLC, the other signals such as enabled signal still set by terminal or parameter. When setting Po001 to other control mode, PLC is still running, meanwhile

operating mode still runs according to the setting value of Po001.

6.8.2 Servo built-in PLC Software Access Area

FL20 built-in PLC can access So area, Po area, PL area and internal special area. Internal special area starts from P0, end to R255, 256 words in total, bit addressing space is B0-B4095, the address of So area, Po area and PL area can be checked in servo user manual. The description of internal special area shows as followings:

Table8.1 Internal Special Area

Area	Bit addressing space	Content	Remark
R0	B0-B15	Operating Mode(Enabled when Po001=d □ 22)	WR
		0: Command Position; 1: Command Speed; 2: Command Torque; 3: Searching Origin; 4: Analog Speed; 5: Position Pulse; 6: Internal Position; 7: Analog Torque	
R1	B16-B31	Current Mode(Enabled when Po001=d □ 22)	RO
		0: Command Position; 1: Command Speed; 2: Command Torque; 3: Searching Origin; 4: Analog Speed; 5: Position Pulse; 6: Internal Position; 7: Analog Torque	
R2	B32-B47	B32-B47 control word	WR

FL20-SA Series

		<table border="1"> <thead> <tr> <th>Addr</th> <th colspan="2">Content</th> </tr> </thead> <tbody> <tr> <td>B32</td> <td>New command can be received or not, before accomplishing command position mode on the previous position.</td> <td>1: YES; 0: NO;</td> </tr> <tr> <td>B33</td> <td>Command position mode operating mode</td> <td>1: relative position; 0: absolute position;</td> </tr> <tr> <td>B34</td> <td>Previous unfinished command remainder process</td> <td>1: Remainder and new command together; 0: New command</td> </tr> <tr> <td>B35</td> <td>Command position mode activated</td> <td>Rising edge means new command coming</td> </tr> <tr> <td>B36</td> <td>Command position mode activated receive RO</td> <td>Set 1 automatically when new command coming; Reset after B35 resets</td> </tr> <tr> <td>B37</td> <td>Command mode stop</td> <td>1: Stop; 0: Runnable</td> </tr> <tr> <td>B38</td> <td>Speed mode stop acceleration/deceleration</td> <td>1: Stop accel/decel, maintain current speed; 0: Runnable</td> </tr> <tr> <td>B39</td> <td>Origin searching command activated</td> <td>Rising edge activates Falling edge stop</td> </tr> </tbody> </table>	Addr	Content		B32	New command can be received or not, before accomplishing command position mode on the previous position.	1: YES; 0: NO;	B33	Command position mode operating mode	1: relative position; 0: absolute position;	B34	Previous unfinished command remainder process	1: Remainder and new command together; 0: New command	B35	Command position mode activated	Rising edge means new command coming	B36	Command position mode activated receive RO	Set 1 automatically when new command coming; Reset after B35 resets	B37	Command mode stop	1: Stop; 0: Runnable	B38	Speed mode stop acceleration/deceleration	1: Stop accel/decel, maintain current speed; 0: Runnable	B39	Origin searching command activated	Rising edge activates Falling edge stop	
Addr	Content																													
B32	New command can be received or not, before accomplishing command position mode on the previous position.	1: YES; 0: NO;																												
B33	Command position mode operating mode	1: relative position; 0: absolute position;																												
B34	Previous unfinished command remainder process	1: Remainder and new command together; 0: New command																												
B35	Command position mode activated	Rising edge means new command coming																												
B36	Command position mode activated receive RO	Set 1 automatically when new command coming; Reset after B35 resets																												
B37	Command mode stop	1: Stop; 0: Runnable																												
B38	Speed mode stop acceleration/deceleration	1: Stop accel/decel, maintain current speed; 0: Runnable																												
B39	Origin searching command activated	Rising edge activates Falling edge stop																												
R3	B48-B63	<p style="text-align: center;">DI State</p> <table border="1"> <thead> <tr> <th>Addr</th> <th>Content</th> <th>Addr</th> <th>Content</th> </tr> </thead> <tbody> <tr> <td>B48</td> <td>DI1</td> <td>B52</td> <td>DI5</td> </tr> <tr> <td>B49</td> <td>DI2</td> <td>B53</td> <td>DI6</td> </tr> <tr> <td>B50</td> <td>DI3</td> <td>B54</td> <td>DI7</td> </tr> <tr> <td>B51</td> <td>DI4</td> <td>B55</td> <td>DI8</td> </tr> </tbody> </table>	Addr	Content	Addr	Content	B48	DI1	B52	DI5	B49	DI2	B53	DI6	B50	DI3	B54	DI7	B51	DI4	B55	DI8	RO							
Addr	Content	Addr	Content																											
B48	DI1	B52	DI5																											
B49	DI2	B53	DI6																											
B50	DI3	B54	DI7																											
B51	DI4	B55	DI8																											
R4	B64-B79	<p style="text-align: center;">Mandatory Valid of DO function</p> <table border="1"> <thead> <tr> <th>Addr</th> <th>Content</th> <th>Addr</th> <th>Content</th> </tr> </thead> <tbody> <tr> <td>B64</td> <td>DO1</td> <td>B67</td> <td>DO4</td> </tr> <tr> <td>B65</td> <td>DO2</td> <td>B68</td> <td>DO5</td> </tr> <tr> <td>B66</td> <td>DO3</td> <td></td> <td></td> </tr> </tbody> </table>	Addr	Content	Addr	Content	B64	DO1	B67	DO4	B65	DO2	B68	DO5	B66	DO3			WR											
Addr	Content	Addr	Content																											
B64	DO1	B67	DO4																											
B65	DO2	B68	DO5																											
B66	DO3																													
R5R6	B80-B111	Mandatory Valid of DI function	WR																											

FL20-SA Series

Addr	Content	Addr	Content	
B80	Enabled	B96	Internal position 1	
B81	Alarm Reset	B97	Internal position 2	
B82	Fwd Torque Limit	B98	Internal position 3	
B83	Rev Torque Limit	B99	Internal position pause	
B84	Speed selection terminal 1	B100	Internal position trigger	
B85	Speed selection terminal 2	B101	Home search trigger	
B86	Speed direction terminal	B102	Origin reference	
B87	Zero-speed clamp	B103	Analog forward	
B88	Gain selection	B104	Analog reverse	
B89	Internal position terminate	B105	Mode switch	
B90	Pulse eliminate	B106	Forward Jog	
B91	Pulse prohibition	B107	Reverse Jog	
B92	Emergency stop	B108	Free	
B93	Reverse prohibition	B109	Interruption fixed length release	
B94	Forward prohibition	B110	Interruption fixed length start	
B95	Free	B111	Gantry synchro start	
DO State				
Addr	Content	Addr	Content	
B112	Servo ready	B113	Enabled	
B114	Rotation detection	B115	Speed Reach	
B116	Position Reach	B117	Torque limiting	
B118	Alarm output	B119	Brake output	
B120	Overload pre-alarm	B121	Speed limiting	
B122	Internal position mode activating	B123	Alarm of excessive position error	
B124	Origin found	B125	Not used	
B126	E-cam action			
R9	B144-B159	Command position speed setting (enable when Po001=d □ 22)		WR
R10R1 1	B160-B191	Command position setting(enable when Po001=d □ 22)		WR

FL20-SA Series

R12	B192-B207	Command position acceleration time(enable when Po001=d □ 22)		WR		
R13	B208-B223	Command position deceleration time(enable when Po001=d □ 22)		WR		
R14	B224-B239	Command position accel/decel source(enable when Po001=d □ 22)		WR		
R15 R16	B240-B271	Command speed setting(enable when Po001=d □ 22)		WR		
R17 R18	B272-B303	Command torque setting(enable when Po001=d □ 22)		WR		
R19 R20	B304-B335	Analog speed		RO		
R21 R22	B336-B367	Analog torque		RO		
R23	B368-B383	Low-speed timer enabled				WR
		Addr.	Content	Addr	Content	
		B368	Low-speed timer 1 enabled	B369	Low-speed timer 2 enabled	
		B370	Low-speed timer 3 enabled	B371	Low-speed timer 4 enabled	
R24	B384-B399	Low-speed timing counter direction				WR
		Addr.	Content	Addr	Content	
		B384	Low-speed timer 1 direction	B385	Low-speed timer 2 direction	
		B386	Low-speed timer 3 direction	B387	Low-speed timer 4 direction	
		Low-speed timing counter reset				
R25	B400-B415	Addr.	Content	Addr.	Content	
		B400	Low-speed timing counter 1 reset	B401	Low-speed timing counter 2 reset	
		B402	Low-speed timing counter 3 reset	B403	Low-speed timing counter 4 reset	
		Low-speed timing counter output				
R26	B416-B431	Low-speed timing counter output		WR		

FL20-SA Series

		Addr.	Content	Addr.	Content			
		B416	Low-speed timing counter 1 output	B417	Low-speed timing counter 2 output			
		B418	Low-speed timing counter 3 output	B419	Low-speed timing counter 4 output			
R27	B432-B447	High-speed timing counter configuration The configuration signal refreshes one time every 0.1ms, the count increments corresponding to high-speed counter in this timing cycle will be latched every time when timer OUT signal rising edge.						WR
		Addr.	Content	Addr.	Content			
		B432	High-speed timer 1 counting signal	B433	High-speed timer 1 enabled			
		B434	High-speed timer 1 reset	B435	High-speed timer 1 direction			
		B436	High-speed timer 2 counting signal	B437	High-speed timer 2 enabled			
		B438	High-speed timer 2 reset	B439	High-speed timer 2 direction			
		B440	High-speed counter 1 reset	B441	High-speed counter 1 enabled			
		B442	High-speed counter 1 direction	B443	High-speed counter 1 CAP			
		B444	High-speed counter 2 reset	B445	High-speed counter 2 enabled			
		B446	High-speed counter 2 direction	B447	High-speed counter 2 CAP			
R28	B448-B463	Low-speed timer counter						WR
		Addr.	Content	Addr.	Content			
		B448	Low-speed timer counter 1 counting signal	B449	Low-speed timer counter 2 counting signal			
		B450	Low-speed timer counter 3 counting signal	B451	Low-speed timer counter 4 counting signal			
R29	B464	High-speed timer						

		Addr.	Content	Addr.	Content
		B464	High-speed timer 1out	B465	High-speed timer 2out
		B466	High-speed counter 1out	B467	High-speed counter 2out
		B468	High-speed timer 1 reset confirmation	B469	High-speed timer 2 reset confirmation
		B470	High-speed counter 1 reset confirmation	B471	High-speed counter 2 reset confirmation
R30 ~ R255	B464 B4095	User space			

6.8.3 Built-in PLC Program Design

Built-in PLC program design is the special instruction of servo drive, customer should program the instructions in strict accordance with the following descriptions, otherwise, instruction compilation error could happen.

Table 6.8.1 Part of Instructions Abbreviation

Name	Content
B□□	PLC internal storage bit addressing address
P□□	Servo parameter address
R□□	PLC internal storage 16-bit addressing address
D□□	16-bit signed number
L□□	32-bit signed number

6.8.3.1 Data Move Instruction

The data moveinstruction is to transfer the source operands of register into the register assigned by destination operands. The data transfer instruction of FL20 built-in PLC includes 16-bit and 32-bit, will be introduced respectively as follows:

(1) 16-bit Move Instruction

Instruction Format: [MOVW□□ X Y]

Instruction Description:

MOVW is move instruction code, □□ is instruction execution register area, X is execution operating register address, Y is destination register address; After executing instructions, the result is Y=X; □□ can be changed for register area according to practical operation, movable area includes R area, P area and immediate operand; See details in table 8.1.1

Table 8.1.1 16-bit Move Instruction Syntax, Results and relatedAnnotations

Syntax Expression	Running Results	Annotations
MOVWRR R10 R2	R2=R10	Data transfer in R area;
MOVWDR D10 R1	R1=10	Immediate operand transfers to R area no.1 register;
MOVWPR P1 R10	R10=Po001	Content of no.1 register in P area transfers to no.10

		register in R area;
MOVWDP D-3 P101	Po101=-3	Immediate operand transfers to no.101 register in P area;
MOVWRP R10 P101	Po101=R10	No.10 register of R area transfers to no.101 register of P area;
MOVWPP P1 P2	Po002=Po001	Data transfer in P area;

(2)32-bit Move Instruction

Instruction Format: [MOVD□□ X Y]

Instruction Description: MOVD is move instruction code, □□ is instruction execution register area, X is execution operating register address, Y is destination register address; After executing instructions, the result is Y=X, of which register address of X, Y need dividing into high-low bits to store the data.

□□ can be changed for register area according to practical operation, movable area includes R area, P area and immediate operand; See details in table 8.1.2;

Table 8.1.2 32-bit Move Instruction Syntax, Results and related Annotations

Syntax Expression	Running Results	Annotations
MOVDRR R10 R2	R3 R2=R11 R10	Data transfer in R area;
MOVDDR L10 R1	R2 R1=10	Immediate operand transfers to R area no.1 register;
MOV DPR P1 R10	R11 R10=Po002 Po001	Content of no.1 register in P area transfers to no.101 register in R area;
MOVDDP L-3 P101	Po102 Po101=-3	Immediate operand sends to no.101 register in P area;
MOVDRP R10 P101	Po102 Po101=R11 R10	No.10 register of R area transfers to no.101 register of P area;
MOVDP P1 P3	Po004 Po003=Po002 Po001	Data transfer in P area;

6.8.3.2 Arithmetic Instruction

The arithmetic instruction has characteristics of strong operation function and rich instructions, it includes add instruction (ADD), sub instruction (SUB), multiplying instruction (MUL), division instruction (DIV) and special application instruction.

(1) Add Instruction

There are 12 add instructions, which are 16-bit addition and 32-bit addition, see details as below:

a) 16-bit addition:

Instruction Format: [ADDW□□ X Y Z]

Instruction Description:

ADDW is addition instruction, □□ is instruction execution register area; X is addend; Y is augend; Z stores results; The result of instruction execution is Z=X+Y, which means the value of register in X area added to the value of register of Y area, the result sends to Z register address. User can operate for R area, P area and immediate operand; See details as table 8.1.3

Table 8.1.3 16-bit Add Instruction Syntax, Results and related Annotations

Syntax Expression	Running Results	Annotations
ADDWRR R1 R2 R3	R3=R1+R2	Two register contents in R area are added, the result sends to no.3 register in R area;

ADDWDR D1 R2 R3	$R3=R2+D1$	Immediate operand added to the value of R register, the result sends to no.3 register in R area;
ADDWPR P1 R2 R3	$R3=R2+P1$	The value of register in P area added to the value of register in R area, the result sends to no.3 register in R area;
ADDWDP D1 P2 R3	$R3=D1+P2$	Immediate operand added to the value of P register, the result sends to no.3 register in R area;
ADDWRP R1 P2 R3	$R3=R1+P2$	The value of register in R area added to the value of register in P area, the result sends to no.3 register in R area;
ADDWPP P1 P2 P3	$R3=P1+P2$	Two register contents in P area are added, the result sends to no.3 register in R area;

b) 32-bit addition:

Instruction Format: [ADDD□□ X Y Z]

Instruction Description:

ADDD is addition instruction, □□ is instruction execution register area; X is addend; Y is augend; Z stores results; The result of instruction execution is $Z=X+Y$, which means the value of register in X area added to the value of register of Y area, the result sends to Z register address. User can operate for R area, P area and immediate operand; See details as table 8.1.4

Table 8.1.4 32-bit Add Instruction Syntax, Results and related Annotations

Syntax Expression	Running Results	Annotations
ADDDRR R1 R2 R3	$R3=R1+R2$	Two register contents in R area are added, the result sends to no.3 register in R area;
ADDDDR D1 R2 R3	$R3=R2+D1$	Immediate operand added to the value of R register, the result sends to no.3 register in R area;
ADDDPR P1 R2 R3	$R3=R2+P1$	The value of register in P area added to the value of register in R area, the result sends to no.3 register in R area;
ADDDDP D1 P2 R3	$R3=D1+P2$	Immediate operand added to the value of P register, the result sends to no.3 register in R area;
ADDDRP R1 P2 R3	$R3=R1+P2$	The value of register in R area added to the value of register in P area, the result sends to no.3 register in R area;
ADDDPP P1 P2 P3	$R3=P1+P2$	Two values of register in P area are added, the result sends to no.3 register in R area;

(2) Subtraction Instruction

There are 12 sub instructions, which are 16-bit subtraction and 32-bit subtraction, see details as below:

a) 16-bit subtraction:

Instruction Format:[SUBW□□ X Y Z]

Instruction Description:

SUBW is subtraction instruction, □□ is instruction execution register area; X is subtrahend; Y is minuend, Z is store result area; The result of instruction execution is $Z=X-Y$, which means that the value of register address in X area is subtracted to the value of register address in Y area, the result sends to Z register address; User can operate for R area, P area and immediate operand; See details as table 8.1.5.

Table 8.1.5 16-bit Sub Instruction Syntax, Results and related Annotations

Syntax Expression	Running Results	Annotations
SUBWRR R1 R2 R3	$R3=R1-R2$	The value of two registers in R area are subtracted, the result sends to no.3 register in R area;
SUBWDR D1 R2 R3	$R3= D1-R2$	Immediate operand subtracted to the value of R register, the result sends to no.3 register in R area;
SUBWPR P1 R2 R3	$R3=R2-P1$	The value of register in P area subtracted to the value of register in R area, the result sends to no.3 register in R area;
SUBWDP D1 P2 R3	$R3=D1-P2$	Immediate operand subtracted to the value of P register, the result sends to no.3 register in R area;
SUBWRP R1 P2 R3	$R3=R1-P2$	The value of R register subtracted to the value of P register, the result sends to no.3 register in R area;
SUBWPP P1 P2 P3	$R3=P1-P2$	The values of two registers in P area are subtracted, the result sends to no.3 register in R area;

b) 32-bit subtraction:

Instruction Format:[SUBD□□ X Y Z]

Instruction Description:SUBD is subtraction instruction, □□ is instruction execution register area; X is subtrahend; Y is minuend, Z is store result area; The result of instruction execution is $Z=X-Y$, which means that the value of register address in X area is subtracted to the value of register address in Y area, the result sends to Z register address; User can operate for R area, P area and immediate operand; See details as table 8.1.6.

Table 8.1.6 32-bit Sub Instruction Syntax, Results and related Annotations

Syntax Expression	Running Results	Annotations
SUBDRR R1 R2 R3	$R3=R1-R2$	The values of two registers in R area are subtracted, the result sends to no.3 register in R area;
SUBDDR D1 R2 R3	$R3= D1-R2$	Immediate operand subtracted to the value of R register, the result sends to no.3 register in R area;
SUBDPR P1 R2 R3	$R3=R2-P1$	The value of register in P area subtracted to the value of

		register in R area, the result sends to no.3 register in R area;
SUBDDP D1 P2 R3	R3=D1-P2	Immediate operand subtracted to the value of P register, the result sends to no.3 register in R area;
SUBDRP R1 P2 R3	R3=R1-P2	The value of R register subtracted to the value of P register, the result sends to no.3 register in R area;
SUBDPP P1 P2 P3	R3=P1-P2	The values of two registers in P area are subtracted, the result sends to no.3 register in R area;

(3) Multiplying Instruction

There are 12 multiplying instructions, which are 16-bit and 32-bit multiplication, see details as below:

a) 16-bit Multiplication:

Instruction Format: [MULW□□ X Y Z]

Instruction Description: MULW is multiplying instruction, □□ is instruction execution register area; X is multiplier, Y is multiplicand, Z is store result area; The result of instruction execution is $Z=X*Y$, which means that the value of register address in X area multiplied to the value of register address in Y area, the result sends to Z register address; User can operate for R area, P area and immediate operand; See details as table 8.1.7.

Table 8.1.7 16-bit Multiplying Instruction Syntax, Results and related Annotations

Syntax Expression	Running Results	Annotations
MULWRR R1 R2 R3	R4 R3=R1*R2	Multiplying the value of 2 registers in R area, get the 32-bit result, storing to no.3 and no.4 register in R area respectively, of which no.4 stores high 16-bit, no.3 stores low 16-bit.
MULWDR D1 R2 R3	R4 R3=1*R2	Multiplying immediate operand and the value of R register, get 32-bit result, storing to no.3 and no.4 registers in R area respectively, of which no.4 stores high 16-bit, no.3 stores low 16-bit.
MULWPR P1 R2 R3	R4 R3=Po001*R2	Multiplying the values of P register and R register, get the 32-bit result, storing to no.3 and no.4 registers in R area respectively, of which no.4 stores high 16-bit, no.3 stores low 16-bit.
MULWDP D1 P2 R3	R4 R3=1*Po002	Multiplying immediate operand and the value of P register, get the 32-bit result, storing to no.3 and no.4 registers in R area, of which no.4 stores high 16-bit, no.3 stores low 16-bit.

MULWRP R1 P2 R3	R4 R3=R1*Po002	Multiplying the values of R register and P register, get the 32-bit result, storing to no.3 and no.4 registers in R area respectively, of which no.4 stores high 16-bit, no.3 stores low 16-bit.
MULWPP P1 P2 R3	R4 R3=Po001*Po002	Multiplying the value of 2 registers in P area, get the 32-bit result, storing to no.3 and no.4 registers in R area respectively, of which no.4 stores high 16-bit, no.3 stores low 16-bit.

b) 32-bit Multiplication

Instruction Format: [MULD□□ X Y Z]

Instruction Description:MULD is multiplying instruction, □□is instruction execution register area; X is multiplier, Y is multiplicand, Z is store result area; The result of instruction execution is $Z=X*Y$, which means that the value of register address in X area multiplied to the value of register address in Y area, the result sends to Z register address; User can operate for R area, P area and immediate operand; See details as table 8.1.8.

Table 8.1.8 32-bit Multiplying Instruction Syntax, Results and related Annotations

Syntax Expression	Running Results	Annotations
MULDRR R1 R2 R3	R6 R5 R4 R3=R2 R1*R3 R2	Multiplying the value of 2 registers in R area, get the 32-bit result, storing to no.3~no.6 registers in R area, of which no.6 and no.5 store to high 32-bit, no.4 and no.3 store to low 32-bit;
MULDDR L1 R2 R3	R6 R5 R4 R3=1*R3*R2	Multiplying immediate operand and R register, get the 32-bit result, storing to no.3 and no.6 register in R area respectively, of which no.6 and no.5 store to high 32-bit, no.4 and no.3 store to low 32-bit;
MULDPR P1 R2 R3	R6 R5 R4 R3=Po002 Po001*R3 R2	Multiplying P register and R register, get the 32-bit result, storing to no.3~no.6 registers in R area respectively, of which no.6 and no.5 store to high 32-bit, no.4 and no.3 store to low 32-bit;
MULDDP L1 P2 R3	R6 R5 R4 R3=1*Po002 Po001	Multiplying immediate operand and P register, get the 32-bit result, storing to no.3 and no.4 registers in R area respectively, of which no.6 and no.5 store to high 32-bit, no.4 and no.3 store to low 32-bit;
MULDRP R1 P2 R3	R6 R5 R4 R3=R1*Po002	Multiplying the values of R register and P register,

	Po001	get the 32-bit result, storing to no.3 and no.4 registers in R area respectively, of which no.6 and no.5 store to high 32-bit, no.4 and no.3 store to low 32-bit;
MULDPP P1 P2 R3	R6 R5 R4 R3=Po002 Po001*Po003 Po002	Multiplying the value of 2 registers in P area, get 32-bit result, storing to no.3 and no.4 registers in R area respectively, of which no.6 and no.5 store to high 32-bit, no.4 and no.3 store to low 32-bit;

(4) Division Instruction

There are 12 division instructions, which have 16-bit division and 32-bit division, see details as below:

a) 16-bit Division

Instruction format: [DIVW□□ X Y Z]

Instruction Description: DIVW is division instruction, □□ is instruction execution register area, X is divisor, Y is dividend, Z is store result area; The result of instruction execution is $Z=X/Y$, which means that the value of register address in X area divided by the value of register address in Y area, the result sends to Z register address, of which integer of divisor stores to low-bit register address, remainder stores to high-bit register address; User can operate for R area, P area and immediate operand; See details as table 8.1.9.

Table 8.1.9 16-bit Division Instruction Syntax, Results and related Annotations

Syntax Expression	Running Results	Annotations
DIVWRR R1 R2 R3	$R3=R1/R2$ $R4=R1\%R2$	Dividing the value of 2 registers in R area, integer stores to no.3 register, remainder stores to no.4 register.
DIVWDR D1 R2 R3	$R3=I/R2$ $R4=I\%R2$	Dividing immediate operand and the value of R register, integer stores to no.3 register, remainder stores to no.4 register.
DIVWPR P1 R2 R3	$R3=Po001/R2$ $R4=Po001\%R2$	Dividing the value of P register and R register, integer stores to no.3 register, remainder stores to no.4 register.
DIVWDP D1 P2 R3	$R3=I/Po002$ $R4=I\%Po002$	Dividing immediate operand and the value of P register, integer stores to no.3 register, remainder stores to no.4 register.
DIVWRP R1 P2 R3	$R3=R1/Po002$ $R4=R1\%Po002$	Dividing the value of R register and P register, integer stores to no.3 register, remainder stores to no.4 register.
DIVWPP P1 P2 R3	$R3=Po001/Po002$ $R4=Po001\%Po002$	Dividing the value of 2 registers in P area, integer stores to no.3 register, and remainder stores to no.4 register.

	2	
--	---	--

b) 32-bit Division

Instruction format:[DIVD□□ X Y Z]

Instruction Description:DIVD is division instruction, □□is instruction execution register area, X is divisor, Y is dividend, Z is store result area; The result of instruction execution is $Z=X/Y$, which means that the value of register address in X area divided by the value of register address in Y area, the result sends to Z register address, of which integer of divisor stores to low-bit register address, remainder stores to high-bit register address; User can operate for R area, P area and immediate operand; See details as table 8.1.10.

Table 8.1.10 32-bit Division Instruction Syntax, Results and related Annotations

Syntax Expression	Running Results	Annotations
DIVDRR R1 R2 R3	R4 R3=R2 R1/R3 R2 R6 R5=R2 R1%R3 R2	Dividing the values of R area, the result stores to no.3~no.6 registers, integer stores to no.3 and no.4 registers, remainder stores to no.6 and no.5 registers.
DIVDDR L1 R2 R3	R4 R3=R2 R1/R3 R2 R6 R5=R2 R1%R3 R2	Dividing immediate operand and the value of R register, the result saves to no.3~no.6 registers, integer stores to no.3 and no.4 registers, remainder stores to no.6 and no.5 registers.
DIVDPR P1 R2 R3	R4 R3=R2 R1/R3 R2 R6 R5=R2 R1%R3 R2	Dividing the value of P register and R register, the result saves to no.3~no.6 registers, integer stores to no.3 and no.4 registers, remainder stores to no.6 and no.5 registers.
DIVDDP L1 P2 R3	R4 R3=R2 R1/R3 R2 R6 R5=R2 R1%R3 R2	Dividing immediate operand and the value of P register, the result saves to no.3~no.6 registers, integer stores to no.3 and no.4 registers, remainder stores to no.6 and no.5 registers.
DIVDRP R1 P2 R3	R4 R3=R2 R1/R3 R2 R6 R5=R2 R1%R3 R2	Dividing the value of R register and P register, the result saves to no.3~no.6 registers, integer stores to no.3 and no.4 registers, remainder stores to no.6 and no.5 registers.
DIVDPP P1 P2 R3	R4 R3=R2 R1/R3 R2 R6 R5=R2 R1%R3 R2	Dividing the value of 2 registers in P area, the result saves to no.3~no.6 registers, integer stores to no.3 and no.4 registers, remainder store to no.6 and no.5 registers;

(5) Scaling Instruction

a) Scaling Division

Instruction Format: [QDIV□□ D X Y Z]

Instruction Description:

QDIV is instruction code, □□ is instruction execution register area, D is result scaling value, X is divisor, Y is dividend, Z is result storing address; User can operate for R area, P area and immediate operand;

See details as table below:

Syntax Expression	Annotations
QDIVRR D7 R1 R3 R5	The value saved in R2/R1 divided by the value of R4/R3, get Q7 scaling result, and save the result into R6/R5;
QDIVDR D7 L1 R3 R5	Immediate operand divided by the value of R4/R3, get Q7 scaling result, and save the result into R6/R5;
QDIVPR D7 P1 R3 R5	The value saved in P2/P1 divided by the value of R4/R3, get Q7 scaling result, and save the result into R6/R5;
QDIVRP D7 R1 P3 R5	The value saved in R2/R1 divided by the value of P4/P3, get Q7 scaling result, and save the result into R6/R5;
QDIVDP D7 L1 P3 R5	Immediate operand divided by the value of R4/R3, get Q7 scaling result, and save the result into R6/R5;
QDIVPP D7 P1 P3 R5	The value saved in P2/P1 divided by the value of R4/R3, get Q7 scaling result, and save the result into R6/R5;

b) Scaling Multiplication

Instruction Format: [QMUL□□ D X D Y D Z]

Instruction Description: QMUL is instruction code, □□ is instruction execution register address, D is result-scaling value, X is multiplier, Y is multiplicand, Z is store result area;

User can operate for R area, P area and immediate operand; See details as table below:

Syntax Expression	Annotations
QMULRR D14 R1 D10 R3 D2 R5	Multiplying Q10 scaling value saved in R2/R1 and Q2 scaling value saved in R4/R3, get Q14 scaling value, and save the result into the address of R6/R5.
QMULDR D14 L1 D10 R3 D2 R5	Multiplying Q10 scaling value of immediate operand and Q2 scaling value saved in R4/R3, get Q14 scaling value, and save the result into the address of R6/R5.
QMULPR D14 P1 D10 R3 D2 R5	Multiplying Q10 scaling value saved in P2/P1 and Q2 scaling value saved in R4/R3, get Q14 scaling value, and save the result into the address of R6/R5.
QMULRP D14 R1 D10 P3 D2 R5	Multiplying Q10 scaling value saved in R2/R1 and Q2 scaling value saved in R4/R3, get Q14 scaling value, and save the result into the address of R6/R5.
QMULDP D14 L1 D10 P3 D2 R5	Multiplying Q10 scaling value of immediate operand and Q2 scaling value saved in P4/P3, get Q14 scaling value, and save the result into the

	address of R6/R5.
QMULPP D14 P1 D10 P3 D2 R5	Multiplying Q10 scaling value saved in P2/P1 and Q2 scaling value saved in P4/P3, get Q14 scaling value, and save the result into the address of R6/R5.

c) Integer Convert Scaling Value

Instruction Format: [ITOQ □ D X Y]

Instruction Description:

ITOQ is instruction code, □ is instruction execution register area, D is result scaling value, X is the register address which needs to convert; Y is result storing register address;

User can operate for R area, P area and immediate operand; See details as table below:

Syntax Expression	Annotations
ITOQR D14 R1 R3	Q14 scaling for the value of R1/R2 register, and save result into R4/R3 register;
ITOQP D14 P1 R1	Q14 scaling for the value of P1/P2 register, and save result into R2/R1 register;

d) Scaling Value Convert Integer

Instruction Format: [QTOI □ D X Y]

Instruction Description: QTOI is instruction code, □ is instruction execution register area, D is result scaling value, X is the register address which needs to convert; Y is result storing register address;

User can operate for R area, P area and immediate operand; See details as table below:

Syntax Expression	Annotations
QTOIR D14 R1 R3	Q14 scaling for the value of R1/R2 register, and save the result into R4/R3 register;
QTOIP D14 P1 R1	Q14 scaling for the value of P1/P2 register, and save the result into R2/R1 register;

6.8.3.3 Logic Instruction

FL20 built-in PLC logic instruction includes “and” instruction (AND), “or” instruction (OR), “exclusive OR” instruction (XOR), unsigned shift instruction (SH), signed shift instruction (SA), rotating shift instruction (RO) etc. See details as below:

(1) Logical Decision Instruction

Logical decision instruction can be divided into normally open and normally closed.

Instruction Format: [LD □ X]

Instruction Description: LD means logic instruction, □ means reversing program or not, X means register address; Determine the state of X, execute next instruction if TRUE, see details as table 8.1.11;

Table 8.1.11 Logical Decision Instruction Syntax, Results and related Annotations

Syntax Expression	Running Result	Annotations
-------------------	----------------	-------------

LD B1	IF (B1)	Similar as normally-open contact in PLC, if variable is TRUE, then contact is closed, and start to execute next instruction;
LDI B2	IF (! B2)	Similar as normally-closed contact in PLC, if variable is TRUE, then contact is open;

(2) “And” Instruction

There are 2 “And” Instructions, see details as below:

Instruction Format: [AN□ X]

Instruction Description: ANis logic instruction, □ means reversing program or not, X means register address; execute “and” instruction with last instruction for X register address; See details as table 8.1.12

Table 8.1.12 “AND”Instruction Syntax, Results and related Annotations

Syntax Expression	Running Result	Annotations
AND B16	&B16	B16 register address executes “and” instruction with last instruction;
ANI B17	& (! B17)	Reversing the content of B17 register address, then executes“and” instruction with last instruction;
ANB		“AND” instruction of series circuits with two or more contacts

(3) “OR” Instruction

There are 2 “or” instructions, see details as below:

Instruction Format: [OR□ X]

Instruction Description: OR is logic instruction, □ means reversing program or not, X means register address; Execute “or” instruction with last instruction for X register address;

Table 8.1.13 “OR” Instruction Syntax, Results and related Annotations

Syntax Expression	Running Result	Annotations
OR B5	(B5)	B5 register address executes “or” instruction with last instruction;
ORI B7	(! B7)	Reversing the content of B7 register address, then executes“or” instruction with last instruction;
ORB		“OR” instruction of series circuits with two or more contacts

(4) Exclusive OR Instruction

There are 2 xor instructions, see details as below:

Instruction Format: [XOR□ X]

Instruction Description: XOR is logic instruction, □ means reversing program or not,X means register address; Execute “XOR” instruction with last instruction for X register address;

Table 8.1.14 “XOR” Instruction Syntax, Results and related Annotations

Syntax Expression	Running Result	Annotations
-------------------	----------------	-------------

XOR B0	$\wedge (B0)$	B0 register address executes “xor” instruction with last instruction;
XORI B1	$\wedge (! B1)$	Reversing the content of B1 register address, then executes“xor” instruction with last instruction;

(5) Logical Inversion Instruction

Instruction Format: [INV X]

Instruction Description:

INV is logic instruction;X means register address; Reversing the content of X register address;

Syntax Expression	Running Result	Annotations
INV B0	!B0	Reversing the content of B0 register address;

(6) Shift Instruction

Shift instruction can be divided into left shift and right shift, can also be divided into signed number and unsigned number based on data type, see details as tables below:

Table 8.1.15 16-bit Unsigned Left Shift

Syntax Expression	Running Result	Annotations
SHLWR R1 D1	$R1=R1\ll 1$	The content of R1 register shift left one bit
SHLWR P1 D1	$Po001=Po001\ll 1$	The content of P1 register shift left one bit

Table 8.1.16 16-bit Unsigned Right Shift

Syntax Expression	Running Result	Annotations
SHRWR R1 D1	$R1=R1\gg 1$	The content of R1 register shift right one bit
SHRWP P1 D1	$Po001=Po001\gg 1$	The content of P1 register shift right one bit

Table 8.1.17 32-bit Unsigned Left Shift

Syntax Expression	Running Result	Annotations
SHLDR R1 D1	$R2 R1=R2 R1\ll 1$	The content of R1 register shift left one bit, of which high-bit stores to R2 register, low-bit stores to R1 register;
SHLDP P1 D1	$Po002 Po001= Po002 Po001\ll 1$	The content of P1 register shift left one bit , of which high-bit stores to P2 register, low-bit stores to P1 register;

Table 8.1.18 32-bit Unsigned Right Shift

Syntax Expression	Running Result	Annotations
SHRDR R1 D1	$R2 R1=R2 R1\gg 1$	The content of R1 register shift right one bit, of which high-bit stores to R2 register, low-bit stores to R1 register;

SHRDP P1 D1	Po002 Po001= Po002 Po001>>1	The content of P1 register shift right one bit, of which high-bit stores to P2 register, low-bit stores to P1 register;
-------------	-----------------------------	---

Table 8.1.19 16-bit Signed Left Shift

Syntax Expression	Running Result	Annotations
SALWR R1 D1	R1=R1<<1	The content of R1 register shift left 1 bit;
SALWP P1 D1	Po001=Po001<<1	The content of P1 register shift left 1 bit;

Table 8.1.20 16-bit Signed Right Shift

Syntax Expression	Running Result	Annotations
SARWR R1 D1	R1=R1>>1	The content of R1 register shift right 1 bit;
SARWP P1 D1	Po001=Po001>>1	The content of P1 register shift right 1 bit;

Table 8.1.21 32-bit Signed Left Shift

Syntax Expression	Running Result	Annotations
SALDR R1 D1	R2 R1=R2 R1<<1	The content of R1 register shift left one bit, of which high-bit stores to R2 register, low-bit stores to R1 register;
SALDP P1 D1	Po002 Po001= Po002 Po001<<1	The content of P1 register shift left one bit , of which high-bit stores to P2 register, low-bit stores to P1 register;

Table 8.1.22 32-bit Unsigned Right Shift

Syntax Expression	Running Result	Annotations
SARDR R1 D1	R2 R1=R2 R1>>1	The content of R1 register shift right one bit, of which high-bit stores to R2 register, low-bit stores to R1 register;
SARDP P1 D1	Po002 Po001= Po002 Po001>>1	The content of P1 register shift right one bit, of which high-bit stores to P2 register, low-bit stores to P1 register;

Table 8.1.23 16-bit Rotate Left Shift

Syntax Expression	Running Result	Annotations
ROLWR R1 D1	R1=R1<<1	The content of R1 register shift left 1 bit;
ROLWP P1 D1	Po001=Po001<<1	The content of P1 register shift left 1 bit;

Table 8.1.24 32-bit Rotate Left Shift

Syntax Expression	Running Result	Annotations
ROLDR R1 D1	R1=R1<<1	The content of R1 register shift left 1 bit;
ROLDP P1 D1	Po001=Po001<<1	The content of P1 register shift left 1 bit;

Table 8.1.25 16-bit Rotate Rghit Shift

Syntax Expression	Running Result	Annotations
RORWR R1 D1	$R1=R1>>1$	The content of R1 register shift right 1 bit;
RORWP P1 D1	$Po001=Po001>>1$	The content of P1 register shift right 1 bit;

Table 8.1.26 32-bit Rotate Rghit Shift

Syntax Expression	Running Result	Annotations
RORDR R1 D1	$R1=R1>>1$	The content of R1 register shift right 1 bit;
RORDP P1 D1	$Po001=Po001>>1$	The content of P1 register shift right 1 bit;

6.8.3.4 Program Control Instruction

Program Control Instruction includes output instruction, jump instruction, stack instruction and other program control instruction, see details as below:

(1) Stack Instruction

Table 8.1.27 Stack Instruction

Syntax Expression	Annotations
MPS	Push current instruction into stack
MRD	Read logic status
MPP	Popup stack logic status

【Note】 The max depth of stack is level 8;

(2) Jump Instruction

Table 8.1.28 Jump Instruction

Syntax Expression	Running Result	Annotations
JUMP R11	Jump to R11 memory address	Jump to specified address

Execute the instruction and refresh control signal of low-speed timer, if current main loop has not finished executing instructions yet, it will skip the rest instructions and wait for the next main loop execution. Jump instruction must be executed in the ending of program, or the program will stop running.

(3) End instruction

Syntax Expression	Running Result	Annotations
END	Jump to 0 address	Jump to 0 address

Execute the instruction and refresh control signal of low-speed timer, if current main loop has not finished executing instructions yet, it will skip the rest instructions and wait for the next main loop execution. End instruction must be executed in the ending of program, or the program will stop running.

There are 13 other program control instructions, see details as below:

(1) Rising Edge Instruction

Instruction Format: [PLS X Y]

Instruction Description:

PLS is instruction code, X stores the register address of last cyclic state, detect the rising edge of Y register address; When detecting the rising edge of Y register address, Y register=1 in this cycle, and X register saves last cyclic state.

(2) Falling Edge Instruction

Instruction Format: [PLF X Y]

Instruction Description: PLF is instruction code, X stores the register address of last cyclic state, detect the falling edge of Y register address; When detecting the falling edge of Y register address, Y register=1 in this cycle, and X register saves last cyclic state.

Table 8.1.29 Rising Edge and Falling Edge Syntax, Results and related Annotations

Syntax Expression	Annotations
PLS B12 B13	When detecting the rising edge of B13 register, B13 register=1 in this cycle and B12 stores last cyclic state.
PLF B12 B13	When detecting the falling edge of B13 register, B13 register=1 in this cycle and B12 stores last cyclic state.

(3) Output Instruction

Instruction Format: [OUT X]

Instruction Description:

OUT is instruction code, X is target register; Output the result of program to X register address;

Syntax Expression	Annotations
OUT B100	Output the result of program to B100 register address

(4) Main Control Instruction

Instruction Format: [MC]

Instruction Description: MC is instruction code; If current logic state is valid, the setting address is valid, so the code between MC and MCR will be in valid status; Otherwise, if current logic state is invalid, the setting address is invalid, so the code between MC and MCR will be in invalid status;

(5) Main Control Reset Instruction

Instruction Format: [MCR]

Instruction Description: MCR is instruction code; same as MC;

(6) Set Instruction

Instruction Format: [SET X]

Instruction Description:

SET is instruction code, X is target register address; Set the content of X register address as 1;

(7) Reset Instruction

Instruction Format: [RST X]

Instruction Description:

RST is instruction code, X is target register address; Set the content of B2 register as 0;

(8) 16-bit Absolute Value

Instruction Format: [ABSW□ X Y]

Instruction Description: ABSW is instruction code, □ is instruction execution register area, X is target register address, Y is the register address that stores results, take the content of X register address as absolute value, and store the results into Y register;

User can operate for R area, P area and immediate operand; See details as table below:

Syntax Expression	Running Result	Annotations
ABSWR R1 R2	R2=ABS(R1)	Take the content of R1 register address as absolute register, and store the results into R2 register.
ABSWP P1 R2	R2=ABS(Po001)	Take the content of P1 register address as absolute register, and store the results into R2 register.

(9) 32-bit Absolute Value

Instruction Format: [ABSD□ X Y]

Instruction Description: ABSD is instruction code, □ is instruction execution register area, X is target register address; Y is the register address that stores results, take the content of X register address as absolute value, and store the results into Y register;

Syntax Expression	Running Result	Annotations
ABSDR R1 R3	R4 R3=ABS(R2 R1)	Take the content of R3 register address as absolute value, and store the result into R1 register, of which high-bit stores into R4, low-bit stores into R3;
ABSDP P1 R2	R3 R2=ABS(Po002 Po001)	Take the content of P1 register address as absolute value, and store the result into R2 register, of which high-bit stores into R3, low-bit stores into R2;

(10) Extension Instruction

Instruction Format: [EXT□ X Y]

Instruction Description:

EXT is instruction code, □ is instruction execution register area, X is target register address; Y is the register address that stores result, extend the value of X register address, and store the result into Y register;

Syntax Expression	Running Result	Annotations
EXTR R1 R2	R3 R2=R1	Extend the content of R2 register address, and store the result into R1 register address;
EXTP P1 R2	R3 R3=Po001	Extend the content of R2 register address, and store the result into P1 register address;

(11) Idle Instruction

Instruction Format: [IDLE]

Instruction Description: IDLE is instruction code, the program executes a dummy instruction;

(12) Comparison Instruction

The instruction is divided into 16-bit and 32-bit, can also be divided into signed number and unsigned number based on data type, see details as tables below:

a) 16-bit Unsigned Comparison Instruction

Instruction Format: [CMPW□□ X Y Z(n)]

Instruction Description: CMPW is instruction code, □□ is instruction execution register area, X, Y is comparison register address; Z is the register address that stores results, compare the value of X register address with the value of Y register address, and store the result into Z register;

Result output:

If X register value is lower than Y register value, then Z(n)=1; Z(n+1)=0; Z(n+2)=0;

If X register value is higher than Y register value, then Z(n)=0; Z(n+1)=0; Z(n+2)=1;

If X register value equals to Y register value, then Z(n)=0; Z(n+1)=0; Z(n+2)=1;

User can operate for R area, P area and immediate operand; See details as table below:

Syntax Expression	Annotations
CMPWRR R1 R2 B0	Compare R1 register value with R2 register value, send result into B0-B3 register.
CMPWDR D1 R2 B0	Compare immediate operand 1 with R2 register value, send result into B0-B3 register.
CMPWPR P1 R2 B0	Compare P1 register value with R2 register value, send result into B0-B3 register.
CMPWDP D1 P2 B0	Compare immediate operand 1 with P2 register value, send result into B0-B3 register.
CMPWRP R1 P2 B0	Compare R1 register value with P2 register value, send result into B0-B3 register.
CMPWPP P1 P2 B0	Compare P1 register value with P2 register value, send result into B0-B3 register.

b) 16-bit Signed Comparison Instruction

Instruction Format: [CMPWS□□ X Y Z(n)]

Instruction Description: CMPWS is instruction code, □□ is instruction execution register area, X, Y is comparison register address; Z is the register address that stores results, compare the value of X register address with the value of Y register address, and store the result into Z register;

Result outputs:

If X register value is lower than Y register value, then Z(n)=1; Z(n+1)=0; Z(n+2)=0;

If X register value is larger than Y register value, then Z(n)=0; Z(n+1)=0; Z(n+2)=1;

If X register value equals to Y register value, then Z(n)=0; Z(n+1)=0; Z(n+2)=1;

User can operate for R area, P area and immediate operand; See details as table below:

Syntax Expression	Annotations
CMPWSSR R1 R2 B0	Compare R1 register value with R2 register value, send result into B0-B3 register.
CMPWSDR D1 R2 B0	Compare immediate operand 1 with R2 register value, send result into B0-B3 register.
CMPWSPR P1 R2 B0	Compare P1 register value with R2 register value, send result into B0-B3 register.
CMPWSDP D1 P2 B0	Compare immediate operand 1 with P2 register value, send result into B0-B3 register.
CMPWSRP R1 P2 B0	Compare R1 register value with P2 register value, send result into B0-B3 register.
CMPWSPP P1 P2 B0	Compare P1 register value with P2 register value, send result into B0-B3 register.

c) 32-bit Unsigned Comparison Instruction

Instruction Format: [CMPD□□ X Y Z(n)]

Instruction Description: CMPD is instruction code, □□ is instruction execution register area, X,Yis comparison register address; Z is the register address that stores results, compare the value of X register address with the value of Y register address, and store the result into Z register;

Result outputs:

If X register value is lower than Y register value, then Z(n)=1; Z(n+1)=0; Z(n+2)=0;

If X register value is larger than Y register value, then Z(n)=0; Z(n+1)=0; Z(n+2)=1;

If X register value equals to Y register value, then Z(n)=0; Z(n+1)=0; Z(n+2)=1;

User can operate for R area, P area and immediate operand; See details as table below:

Syntax Expression	Annotations
CMPDRR R1 R2 B0	Compare R1 register value with R2 register value, send result into B0-B3 register.
CMPDDR D1 R2 B0	Compare immediate operand 1 with R2 register value, send result into B0-B3 register.
CMPDPR P1 R2 B0	Compare P1 register value with R2 register value, send result into B0-B3 register.
CMPDDP D1 P2 B0	Compare immediate operand 1 with P2 register value, send result into B0-B3 register.
CMPDRP R1 P2 B0	Compare R1 register value with P2 register value, send result into B0-B3 register.
CMPDPP P1 P2 B0	Compare P1 register value with P2 register value, send result into B0-B3 register.

d) 32-bit Signed Comparison Instruction

Instruction Format: [CMPDS□□ X Y Z(n)]

Instruction Description: CMPDS is instruction code, □□ is instruction execution register area, X,Yis comparison register address; Z is the register address that stores results, compare the value of X register address with the value of Y register address, and store the result into Z register;

Result outputs:

If X register value is lower than Y register value, then Z(n)=1; Z(n+1)=0; Z(n+2)=0;

If X register value is larger than Y register value, then Z(n)=0; Z(n+1)=0; Z(n+2)=1;

If X register value equals to Y register value, then Z(n)=0; Z(n+1)=0; Z(n+2)=1;

User can operate for R area, P area and immediate operand; See details as table below:

Syntax Expression	Annotations
CMPDSRR R1 R2 B0	Compare R1 register value with R2 register value, send result into B0-B3 register.
CMPDSDR D1 R2 B0	Compare immediate operand 1 with R2 register value, send result into B0-B3 register.
CMPDSPR P1 R2 B0	Compare P1 register value with R2 register value, send result into B0-B3 register.
CMPSDP D1 P2 B0	Compare immediate operand 1 with P2 register value, send result into B0-B3 register.
CMPDSRP R1 P2 B0	Compare R1 register value with P2 register value, send result into B0-B3 register.
CMPDSPP P1 P2 B0	Compare P1 register value with P2 register value, send result into B0-B3 register.

6.8.4 Built-in PLC Parameters

PL170	PLC Start Function PLC			
	Setting Range	Setting Unit	Mfr's Value	Effect
	0~1	N/A	0	Effective Immediately
	0: Not start PLC function; 1: Start PLC function;			
PL172	PLC Start Address PLC			
	Setting Range	Setting Unit	Mfr's Value	Effect
	0~2000	N/A	0	Effective Immediately
PL174	PLC Reset PLC			
	Setting Range	Setting Unit	Mfr's Value	Effect
	0~1	N/A	0	Effective Immediately
	0: Not reset PLC function; 1: Reset PLC function;			
PL130	Low-speed Timer 1 Configuration PLC			
	Setting Range	Setting Unit	Mfr's Value	Effect
	Two-parameter	N/A	00	Effective Immediately

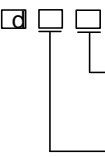
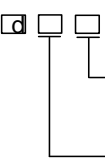
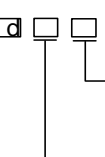
	 <table border="1" data-bbox="689 208 972 390"> <tr><th>X</th><th>Timer Mode</th></tr> <tr><td>0</td><td>Reach set value and maintain</td></tr> <tr><td>1</td><td>Reach set value and continue to count</td></tr> <tr><th>Y</th><th>Count Source</th></tr> <tr><td>0</td><td>10ms</td></tr> <tr><td>1</td><td>100ms</td></tr> <tr><td>2</td><td>PLC stores B448</td></tr> </table>				X	Timer Mode	0	Reach set value and maintain	1	Reach set value and continue to count	Y	Count Source	0	10ms	1	100ms	2	PLC stores B448
X	Timer Mode																	
0	Reach set value and maintain																	
1	Reach set value and continue to count																	
Y	Count Source																	
0	10ms																	
1	100ms																	
2	PLC stores B448																	
PL131	Low-speed timer 2 Configuration PLC																	
	Setting Range	Setting Unit	Mfr's Value	Effect														
	Two-parameter	N/A	00	Effective Immediately														
	 <table border="1" data-bbox="689 624 972 807"> <tr><th>X</th><th>Timer Mode</th></tr> <tr><td>0</td><td>Reach set value and maintain</td></tr> <tr><td>1</td><td>Reach set value and continue to count</td></tr> <tr><th>Y</th><th>Count Source</th></tr> <tr><td>0</td><td>10ms</td></tr> <tr><td>1</td><td>100ms</td></tr> <tr><td>2</td><td>PLC stores B449</td></tr> </table>				X	Timer Mode	0	Reach set value and maintain	1	Reach set value and continue to count	Y	Count Source	0	10ms	1	100ms	2	PLC stores B449
X	Timer Mode																	
0	Reach set value and maintain																	
1	Reach set value and continue to count																	
Y	Count Source																	
0	10ms																	
1	100ms																	
2	PLC stores B449																	
PL132	Low-speed timer 3 Configuration PLC																	
	Setting Range	Setting Unit	Mfr's Value	Effect														
	Two-parameter	N/A	00	Effective Immediately														
	 <table border="1" data-bbox="689 1041 972 1223"> <tr><th>X</th><th>Timer Mode</th></tr> <tr><td>0</td><td>Reach set value and maintain</td></tr> <tr><td>1</td><td>Reach set value and continue to count</td></tr> <tr><th>Y</th><th>Count Source</th></tr> <tr><td>0</td><td>10ms</td></tr> <tr><td>1</td><td>100ms</td></tr> <tr><td>2</td><td>PLC stores B450</td></tr> </table>				X	Timer Mode	0	Reach set value and maintain	1	Reach set value and continue to count	Y	Count Source	0	10ms	1	100ms	2	PLC stores B450
X	Timer Mode																	
0	Reach set value and maintain																	
1	Reach set value and continue to count																	
Y	Count Source																	
0	10ms																	
1	100ms																	
2	PLC stores B450																	
PL133	Low-speed timer 4 Configuration PLC																	
	Setting Range	Setting Unit	Mfr's Value	Effect														
	Two-parameter	N/A	00	Effective Immediately														

	<table border="1" style="display: inline-table; margin-right: 10px;"> <tr><th>X</th><th>Timer Mode</th></tr> <tr><td>0</td><td>Reach set value and maintain</td></tr> <tr><td>1</td><td>Reach set value and continue to count</td></tr> </table> <table border="1" style="display: inline-table;"> <tr><th>Y</th><th>Count Source</th></tr> <tr><td>0</td><td>10ms</td></tr> <tr><td>1</td><td>100ms</td></tr> <tr><td>2</td><td>PLC stores B451</td></tr> </table>				X	Timer Mode	0	Reach set value and maintain	1	Reach set value and continue to count	Y	Count Source	0	10ms	1	100ms	2	PLC stores B451
X	Timer Mode																	
0	Reach set value and maintain																	
1	Reach set value and continue to count																	
Y	Count Source																	
0	10ms																	
1	100ms																	
2	PLC stores B451																	
PL140	Low-speed timer 1 set value [PLC]																	
	Setting Range	Setting Unit	Mfr's Value	Effect														
	-2147483647~+2147483647	N/A	0	Effective Immediately														
PL142	Low-speed timer 2 set value [PLC]																	
	Setting Range	Setting Unit	Mfr's Value	Effect														
	-2147483647~+2147483647	N/A	0	Effective Immediately														
PL144	Low-speed timer 3 set value [PLC]																	
	Setting Range	Setting Unit	Mfr's Value	Effect														
	-2147483647~+2147483647	N/A	0	Effective Immediately														
PL146	Low-speed timer 4 set value [PLC]																	
	Setting Range	Setting Unit	Mfr's Value	Effect														
	-2147483647~+2147483647	N/A	0	Effective Immediately														
PL150	Low-speed timer 1 current value [PLC]																	
	Setting Range	Setting Unit	Mfr's Value	Effect														
	-2147483647~+2147483647	N/A	—	Effective Immediately														
PL152	Low-speed timer 2 current value [PLC]																	
	Setting Range	Setting Unit	Mfr's Value	Effect														
	-2147483647~+2147483647	N/A	—	—														
PL154	Low-speed timer 3 current value [PLC]																	
	Setting Range	Setting Unit	Mfr's Value	Effect														
	-2147483647~+2147483647	N/A	—	—														
PL156	Low-speed timer 4 current value [PLC]																	
	Setting Range	Setting Unit	Mfr's Value	Effect														

FL20-SA Series

	-2147483647~+2147483647	N/A	—	—											
PL160	High-speed counter 1 set PLC														
	Setting Range	Setting Unit	Mfr's Value	Effect											
	Two-parameter	N/A	00	Effective Immediately											
	<table border="1" style="margin-left: 20px;"> <tr><td>X</td><td>Timer Mode</td></tr> <tr><td>0</td><td>Reach set value and maintain</td></tr> <tr><td>1</td><td>Reach set value and continue to count</td></tr> <tr><td>Y</td><td>Count Source</td></tr> <tr><td>0</td><td>0.1ms</td></tr> <tr><td>1</td><td>PLC stores B432</td></tr> </table>				X	Timer Mode	0	Reach set value and maintain	1	Reach set value and continue to count	Y	Count Source	0	0.1ms	1
X	Timer Mode														
0	Reach set value and maintain														
1	Reach set value and continue to count														
Y	Count Source														
0	0.1ms														
1	PLC stores B432														
PL161	High-speed counter 1 set value PLC														
	Setting Range	Setting Unit	Mfr's Value	Effect											
	-2147483647~+2147483647	N/A	0	Effective Immediately											
PL163	High-speed counter 1 current value PLC														
	Setting Range	Setting Unit	Mfr's Value	Effect											
	-2147483647~+2147483647	N/A	—	Effective Immediately											
PL165	High-speed counter 2 set PLC														
	Setting Range	Setting Unit	Mfr's Value	Effect											
	Two-parameter	N/A	00	Effective Immediately											
	<table border="1" style="margin-left: 20px;"> <tr><td>X</td><td>Timer Mode</td></tr> <tr><td>0</td><td>Reach set value and maintain</td></tr> <tr><td>1</td><td>Reach set value and continue to count</td></tr> <tr><td>Y</td><td>Count Source</td></tr> <tr><td>0</td><td>0.1ms</td></tr> <tr><td>1</td><td>PLC stores B436</td></tr> </table>				X	Timer Mode	0	Reach set value and maintain	1	Reach set value and continue to count	Y	Count Source	0	0.1ms	1
X	Timer Mode														
0	Reach set value and maintain														
1	Reach set value and continue to count														
Y	Count Source														
0	0.1ms														
1	PLC stores B436														
PL166	High-speed counter 2 set value PLC														
	Setting Range	Setting Unit	Mfr's Value	Effect											
	-2147483647~+2147483647	N/A	0	Effective Immediately											
PL168	High-speed counter 2 current value PLC														
	Setting Range	Setting Unit	Mfr's Value	Effect											
	-2147483647~+2147483647	N/A	—	—											

6.8.5 Built-in PC/PLC Use and Application Example

To satisfy user requirement, FL20 built-in PLC adopts free installation version. Download the software, double-click ParkerDV shortcut icon, then below interface is displayed:

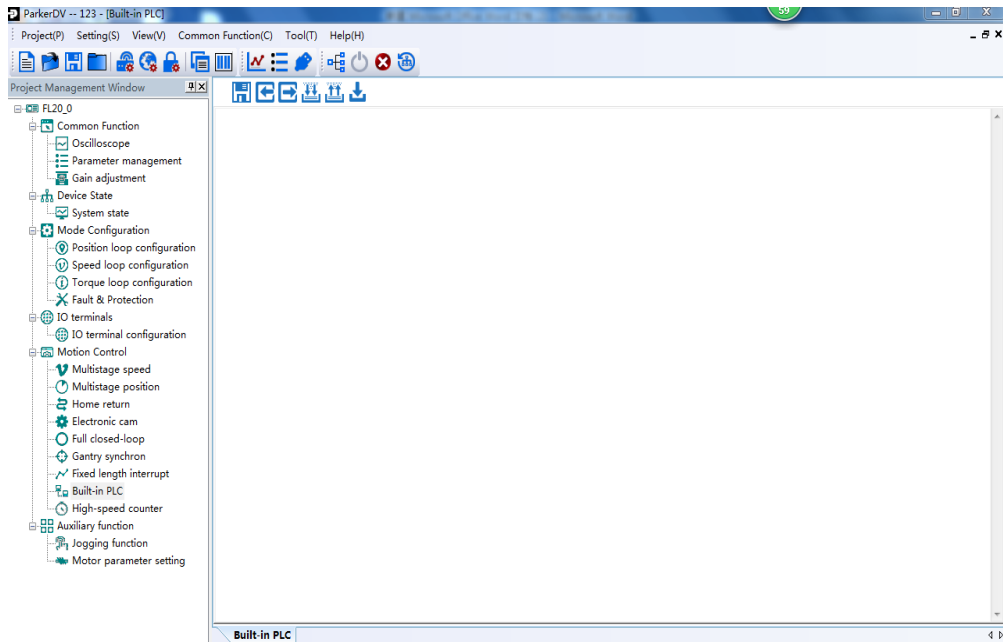

Fig 6.8.1 Interface after double-click

Click built-in PLC, PLC programming interface is displayed.

In menu bar, find **【setting】** → **【communication setting】** command or press shortcut key F4, open Communication Setting window, as following:

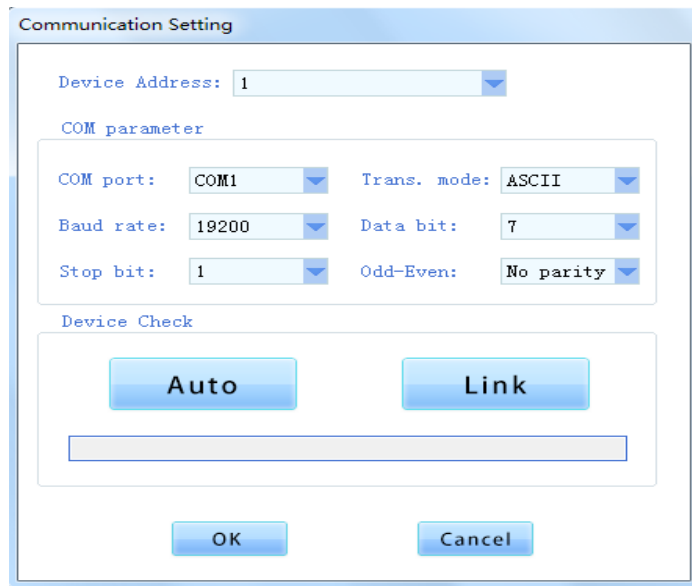

Fig 6.8.2 Communication setting window

After finishing programming, user can compile program. If program is correct, below window will pop up:

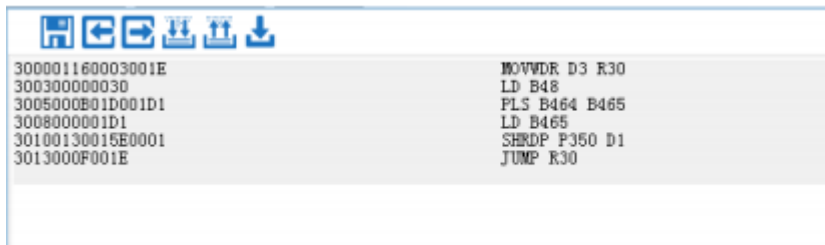

Fig 6.8.3 Program is correct

If program is not correct, following window will pop up.

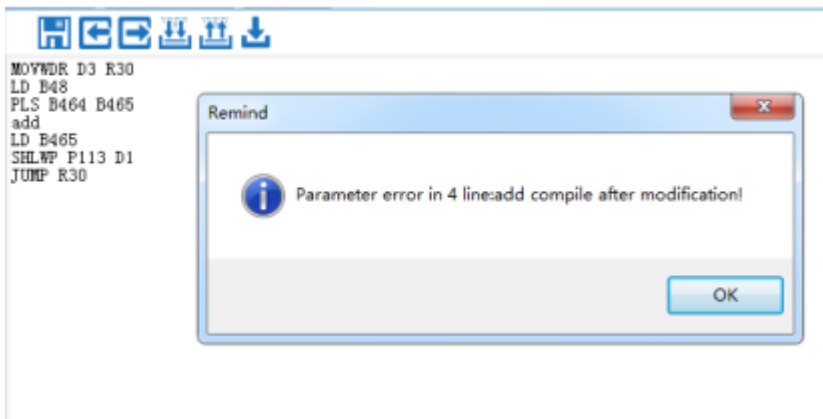

Fig 6.8.4 Program is not correct

Press **【OK】** , user can revise the error line.



Fig 6.8.5 Compiling interface

After finishing programing, user can download program to servo drive by **【File】** → **【download】** or shortcut key F5. Download window will pop up, user can press **【download】** key.

Note: current software doesn't support ladder logic programing, only suport language programming.

6.8.5.1Application Example

The application example illustrates the programming of common instructions:

Case 1: 16-bit Addition Instruction

```
MOVWDR D3 R100          ##Set the starting point of a program;
ADDWDP D1000 P113 R29  ##The value of Po113 added to immediate operand 1000, send the
                        result to R29 area
```

MOVWRP R29 P114 ##Send the result of R29 into Po114, it is convenient to check;
 JUMP R100 ##Echoing first sentence, maintain the program in running status;

Case 2: 16-bit Subtraction Instruction

MOVWDR D3 R100 ##Set the starting point of a program;
 SUBWDP D1000 P113 R29 ##Immediate operand 1000 subtracts the value of Po113, send the
 result into R29 area

MOVWRP R29 P114 ##Send the result of R29 into Po114, it is convenient to check;
 JUMP R100 ##Echoing with first sentence, maintain the program in running
 status;

Case 3: 16-bit Multiplying Instruction

MOVWDR D3 R100 ##Set the starting point of a program;
 MULWDP D100 P113 R29 ##Multiplying immediate operand 100 and the value of Po113, send
 theresult into R29 and R30 area;
 ##R30 stores high-bit, R29 stores low-bit;

MOVWRP R29 P114 ##Send the result of R29 into Po114, it is convenient to check;
 JUMP R100 ##Echoing with first sentence, maintain the program in running
 status;

Case 4: 16-bit Division Instruction

MOVWDR D3 R100 ##Set the starting point of a program;
 DIVWDP D100 P113 R29 ##Dividing immediate operand 100 by the value of Po113, send the
 result into R29 and R39 area. R30 stores remainder;

MOVWRP R29 P114 ##Send the result of R29 into Po114, it is convenient to check;
 MOVWRP R30 P115 ##Send the remainder into Po115, it is convenient to check;
 JUMP R100 ##Echoing with first sentence, maintain the program in running
 status;

Case 5: Logic and Instruction

MOVWDR D3 R100 ##Set the starting point of a program;
 LD B48 ##Judge DI1 status;
 OR B49 ## “OR” instruction for DI1 and DI2;
 OUT B64 ##Send the result into DO1;
 JUMP R100 ##Echoing with first sentence, maintain the program in running
 status;

Case 6: Logic and Instruction

MOVWDR D3 R100 ##Set the starting point of a program;
 LD B48 ##Judge DI1 status;

```
AND B49          ## "AND" instruction for DI1 and DI2;
OUT B64          ##Send the result into DO1;
JUMP R100        ##Echoing with first sentence, maintain the program in running
status;
```

Case 7: Logical block and Instruction

```
MOVWDR D3 R100   ##Set the starting point of a program;
LD B48           ##Judge DI1 status;
MC B464          ##Set B464 valid if DI1=1, meanwhile, execute the program between
MC and MCR.
LD B49           ##Judge DI2 status;
LD B50           ##Judge DI3 status;
LD B51           ##Judge DI4 status;
ANB             ##"AND" instruction for above;
OUT B64          ##Send the result into DO1
MCR             ##
JUMP R100        ##Echoing with first sentence, maintain the program in running
status;
```

Case 8: Program Control Instruction Example

```
MOVWDR D3 R30    ##Set program jump address
LD B48           ##Judge DI1 status
MC B464          ##Set B464 valid if DI1 is enabled, meanwhile, the code between MC and
MCR in executing status;
LD B49           ##Judge DI2 status;
MPS             ##Current logic status pushes into stack
LD B51           ##Judge DI4 status
ANB             ##"AND" instruction for above LD logic status
OUT B64          ##Output result into DO1
MCR             ##Main control program reset
MRD             ##Read stack logic
OUT B65          ##Stack logic outputs to DO2
MPP             ##Popup stack logic
INV             ##Reversing current logic
OUT B66          ##Output current logic to DO3
JUMP R30        ##Jump to R30 address, program continues to execute
```

6.8.6 Built-in PLC Communication Operation

6.8.6.1 MODBUS Address

MODBUS address of PL area start from 1000, see details for built-in PLC address as table below:

Table 1: MODBUS address of built-in PLC area

Address	Content	Range	Remarks
1170	PLC start	0~1	
1172	PLC start address	0~2000	
1174	PLC reset	0~1	

6.8.6.2 DEBUG function of built-in PLC

Table 2: MODBUSAddress and Contents

Address	Content	Range	Remarks
10000	Debug Mode		WR
10001	Single step execution		WR
10002	Running to breakpoint		WR
10003	Breakpoint address		WR
1175	Current address		RO
10100 ~10355	Data of R0~R255		WR

Table 3: DEBUG Mode Function

Action	Debug mode	Single step	Running to breakpoint	Breakpoint address
Running to breakpoint address N, then enter single step mode.	1	0	1	N
In single step mode, single-step executes one instruction, and single-step execute automatic reset	1	1	0	N
Pause in current instruction	1	0	0	N
Run the program normally	0	0	0	N

VII. Adjustments

7.1 Summary

Servo drive needs rapid, accurate drive motor to track PC/PLC or its internal setting instructions. To achieve the requirements, reasonable adjustments for servo gain must be made.

The general process of gain adjustment shows as below:

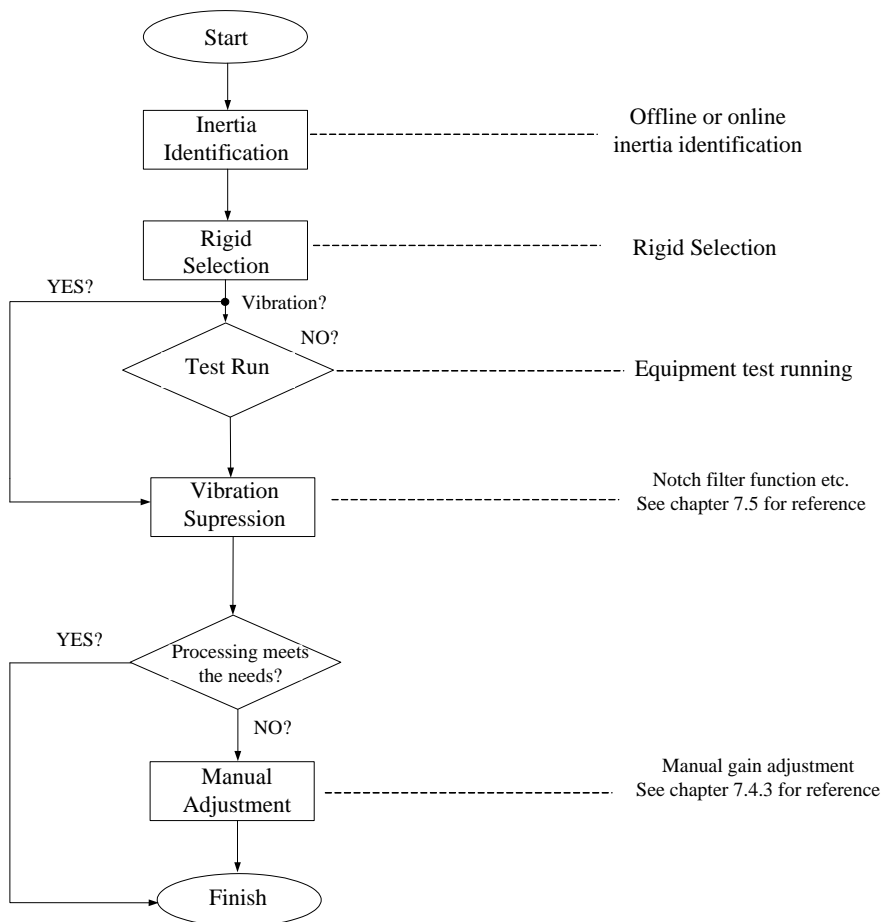

Fig 7.1.1 Gain adjustment flow chart

Note:

- It is recommended that jog test running firstly before gain adjustment to ensure the normal running of motor;
- Servo gain can be set by the combination of multi-parameters (position-loop, speed-loop, filter, load rotational inertia ratio etc.), they influence each other, therefore, the setting of servo gain must consider the balance of each parameter;

7.2 Inertia Identification

After motor is connected to mechanical equipment or motor is installed in load simulator, servo drive needs to “study” the rotational inertia of current equipment before test running for normal production. It is convenient for user to adjust related parameters, and make the servo system run in proper rotational inertia.

Load inertia ratio=(the total rotational inertia of mechanical load)/(the rotational inertia of motor itself)

Load inertia ratio is important parameter of servo system. Set the load inertia ratio correctly is helpful for finishing the debug rapidly. Load inertia ratio can be set either manually or by inertia automatic identification.

Servo drive provides two kinds of inertia identification methods:

1) Offline Inertia Identification

Use “rotational inertia identification function (Po008)”, operate the keys of servo drive to realize inertia identification;

2) Online Inertia Identification

Servo drive identifies current load inertia automatically according to the load condition, the identified value writes to “rotational inertia ratio (Po013)”.



1. If actual load inertia ratio is big and the drive gain is low, motor will be slow and cannot meet the requirements; user can increase the rigidity by Po010 to learn the inertia again;

2. If vibration occurs in the process of inertia learning, user should stop inertia learning Immediate and lower the gain;

7.2.1 Offline Inertia Identification

Servo drive can drive the load running by servo motor according to forward/reverse curve to calculate the rotational inertia ratio of load and confirm the rotational inertia.

Before running offline inertia identification, confirm the content below firstly:

1) The movable distance of motor should satisfy one requirement

Before offline inertia identification, make sure the limit switch is installed in machinery, and ensure that motor has the movable distance of over 1 cycle for each forward and reverse to prevent accident from over-distance in the process of inertia identification; Check the movable distance in the stop position of

current motor is larger than the setting value of Po015, if not, the distance can be increased properly.

2) Estimate load inertia ratio(Po013)

a) Preset Po013 as a bigger initial value;

400 of initial value is recommended as preset value, gradually increase till the displayed value in keypad can be updated with the actual value in the process of identification.

b) Increase the rigidity level of the servo drive properly:

Increase the rigidity level (Po010) properly to meet the requirements of inertia identification.

General operation process of offline inertia identification shows as below:

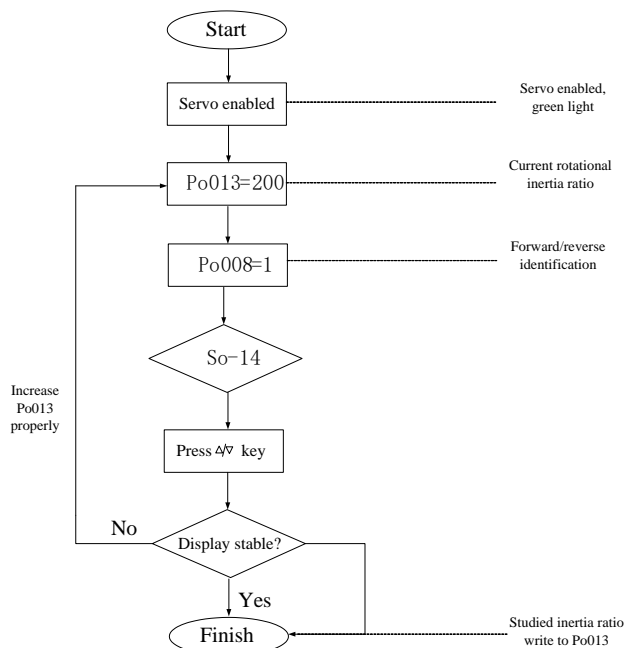

Fig 7.2.1Offline rotational inertia setting flow chart

Related Parameters:

1) Motion range of offline rotational inertia identification(pulse)

Signal Name	Parameter	Setting Range	Mfr's value	Content
Motion range	Po015	200~2147483647	—	Approximate value, One-time identification action finished in setting pulse range.

2) Inertia identification mode selection

Po008	Inertia identification mode selection			speed	position	torque
	Setting Range	Unit	Mfr's Value	Effect		

FL20-SA Series

	0: No start function 1: Offline fwd/rev direction identification. 2: Offline single direction identification. 3: Online auto inertia identification	N/A	0	Effective Immediately Lost if power's off
--	--	-----	---	---

Illustration:

- (1) Po008=0: Not start rotational inertia identification function.
- (2) Po008=1: Offline fwd/rev direction identification, suit for the equipment with limit motion range.
- (3) Po008=2: Offline single direction identification, suit for the equipment, which cannot reverse.
- (4) Po008=3: Online automatic inertia identification; in this mode, servo drive maintains online automatic identification status, when jog running, it displays not “JOG”, but the value of current rotational inertia.

3) Offline rotational inertia identification action gap time

Po009	Offline rotational inertia identification action gap time speed position torque			
	Setting Range	Setting Unit	Mfr's Value	Effect
	10~2000	ms	100	Effective Immediately

4) Motor accel/decel time when offline rotational inertia identification

Po014	Motor accel/decel time speed position torque			
	Setting Range	Setting Unit	Mfr's Value	Effect
	200~5000	ms	1000	Effective Immediately

5) Rotational inertia ratio

Po013	Rotational inertia ratio speed position torque			
	Setting Range	Setting Unit	Mfr's Value	Effect
	1~30000	0.01	200	Effective Immediately

Note: Rotational inertia identification just measures the inertia ratio, does not match speed-location parameter, therefore, please make sure that make the selection of rigidity after finishing rotational inertia identification.

7.2.2 Online Inertia Identification

Online automatic inertia identification:

When Po008=3, enter rotational inertia online automatic identification status, servo drive identifies current load inertia automatically according to load condition.

Note: The condition of online automatic inertia identification shows as below:

- Max rotary speed is higher than 200rpm in the motion process of servomotor.
- The acceleration/deceleration of servomotor is higher than 3000rpm/s.
- The machinery that rigid load is not easy to generate small vibration.
- Slow changing of load inertia
- Mechanical clearance is not big in the motor process

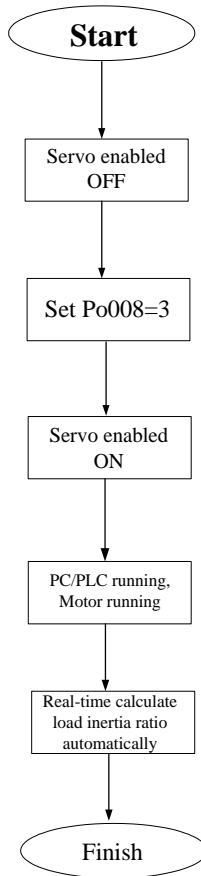

Fig 7.2.2 Online rotational inertia setting flow chart

7.3 Gain Adjustment

7.3.1 Summary

To optimize the responsiveness of servo drive, the setting servo gain needs to adjust. Servo gain needs to set for the combination of multi-parameter, they influence with each other, and therefore, the adjustment of servo gain must consider the relationship of each parameter.

In general, the machinery of high rigidity can improve response performance by increasing servo gain. For the machinery of low rigidity, vibration may occur when increasing servo gain. Therefore, in the occasion of high response requirements, the machinery of high rigidity is needed to avoid mechanical resonance.

The selection of position or speed response frequency must be decided by mechanical rigidity and application occasion. In general, the machinery of high rigidity requires high response frequency, but high response frequency can easily trigger mechanical resonance. If response frequency is unknown, user can increase gain setting gradually to improve response frequency until the resonance happens, then turn down the setting value of gain. Related gain adjustment principle illustrates as below:

The rigidity of servo drive is the ability that motor rotor overcomes load inertia, which is self-locking ability of motor rotor. The stronger servo rigidity is, the bigger corresponding speed-loop gain is, the faster system response speed is.

Servo rigidity must use in conjunction with the rotational inertia of load, the bigger mechanical load rotational inertia is, the lower the rigidity level is. If servo rigidity is higher than rotational inertia ratio, high-frequency self-excited oscillation would happen; whereas, motor would response slowly and take longer to reach the specified location.

Servosystem consists of three control loops, from outside-in: position-loop, speed-loop, current loop, basic control diagram shows as below:

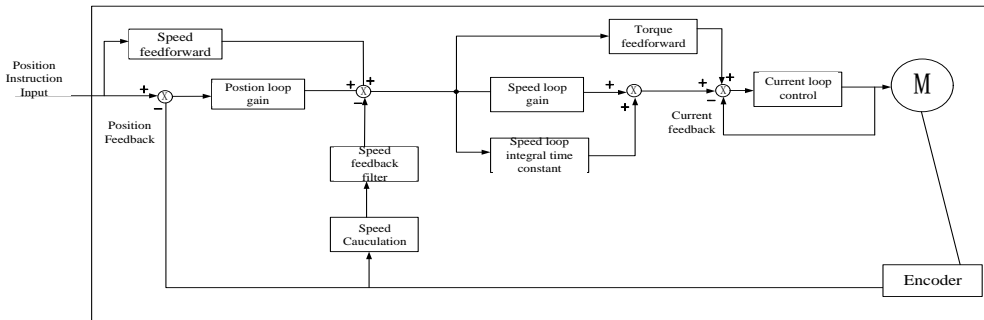



Fig 7.3.1 Servo drive internal frame diagram

Inside loop requires high responsiveness, system may not stable if not following the principle:

The default current loop can ensure the responsiveness that is not need to adjust. The position loop gain, speed loop gain and other auxiliary gain needs adjustment.

7.3.2 Automatic Gain Adjustment

When automatic gain adjustment, use rigidity selection function (Po010), servo drive will generate one group of matching gain parameter to satisfy the requirements of rapidity and stability.

 Make sure obtain load inertia ratio correctly before using the parameter of auto gain adjustment.

Related Parameter:

Po010	Rigidity Selection speed position torque			
	Setting Range	Setting Unit	Mfr's Value	Effect
	1~30	N/A	6	Effective Immediately

Set Po010 for rigidity selection, setting range: 1~19, the bigger value is, the stronger rigidity is. System will generate first group parameters of gain. The first gain group includes: first position loop gain Po301, first speed loop proportional gain Po101, first speed loop integral time Po102, first speed filter time constant Po105, first torque filter time constant Po214, first current loop bandwidth Po200.

Table 7.3.1 Rigidity Level and Related Parameters

Rigidity Level Po010	1 st position loop gain Po301	1 st Speed-loop proportional gain Po101	1 st speed loop integral time Po102	1 st speed filter time constant Po105	1 st current loop bandwidth Po200	1 st torque filter time constant Po214	Servo response speed
1	384	100	5000	3200	1000	0	Slow ↓ Medium ↓ Fast
2	769	200	2500	1668	1000	0	
3	1154	300	1666	1100	1000	0	
4	1538	400	1250	830	1000	0	
5	1923	500	1000	650	1000	0	
6	2423	630	793	529	1000	0	
7	2885	750	666	440	1000	0	
8	3346	870	574	383	1000	0	
9	3846	1000	500	330	1000	0	
10	4308	1120	446	297	1000	0	
11	4808	1250	400	260	1000	0	
12	5270	1370	364	243	1000	0	
13	5770	1500	333	220	1000	0	
14	6231	1620	308	205	1000	0	
15	6731	1750	285	190	1000	0	

FL20-SA Series

16	7193	1870	267	178	1000	0
17	7693	2000	250	160	1000	0
18	8193	2130	234	156	1000	0
19	8655	2250	222	148	1000	0
20	9617	2500	200	130	1000	0
21	10578	2750	181	121	1000	0
22	11540	3000	166	110	1000	0
23	12502	3250	153	102	1000	0
24	13463	3500	142	95	1000	0
25	14425	3750	133	88	1000	0
26	15387	4000	125	83	1000	0
27	16349	4250	117	78	1000	0
28	17310	4500	111	74	1000	0
29	18272	4750	105	70	1000	0
30	19234	5000	100	66	1000	0

Mechanical connection mode:

The machinery with synchro belt driving, chain driving, speed reducer with fluctuation gear→Ball screw controlled by speed reducer or long-size machinery connected with ball bearings directly (Normal working machine, handling machine) →Machinery directly connected with ball screw (machine tool etc.)

Setting method of rigidity level:

1) Confirm that inertia identification has been executed and the inertia ratio is reasonable, estimate proper rigidity level Po010 according to inertia ratio and drive connection mode (the bigger mechanical load is, the lower rigidity level is).

2) So-14 enters jog test running, check the normal operation and noise. Reduce rigidity level Po010 properly if there is any noise. Otherwise, user can try to improve the rigidity level and test running again until satisfying the system requirement.

When changing rigidity level, speed loop gain and position loop gain will change too. After setting rigidity level, user can still make a fine-tuning for the first gain group (not influence rigidity Po010).

The data of table above is related to the parameter of Po010 rigidity level, check the table above for reference when rigidity selection.

7.3.3 Manual Gain Adjustment

User can make fine adjustment manually when the automatic gain adjustment cannot reach the expected effect.

Table 7.3.2 Manual Gain Adjustment Parameter Table

Parameter	Name	Parameter	Name
Po101	1 st Speed loop proportional gain	Po135	Gain 2 switch to gain 1 delay time
Po102	1 st Speed loop integral time	Po200	1 st current loop bandwidth
Po103	2 nd Speed loop proportional gain	Po201	2 nd current loop bandwidth
Po104	2 nd Speed loop integral time	Po214	1 st torque filter time constant
Po105	1 st Speed loop time constant	Po215	2 nd torque filter time constant
Po106	2 nd Speed loop filter time constant	Po301	1 st position loop gain
Po107	Torque feedforward gain	Po302	2 nd position loop gain
Po108	Torque feedforward gain filter	Po303	Position loop feedforward gain
Po130	Gain switching mode	Po306	Position loop filter time constant
Po131	Gain switching speed	Po343	Position mode accel/decel time
Po132	Gain switching pulse	Po229	Notch filter start
Po133	Position loop gain switching time	Po217	1 st Notch filter center frequency
Po134	Speed loop gain switching time	Po218	1 st Notch filter width
Po219	1 st Notch filter depth	Po220	2 nd Notch filter center frequency
Po221	2 nd Notch filter width	Po222	2 nd Notch filter depth
Po223	3 rd Notch filter center frequency	Po224	3 rd Notch filter width
Po225	3 rd Notch filter depth	Po226	4 th Notch filter center frequency
Po227	4 th Notch filter width	Po228	4 th Notch filter depth
Po240	Vibration suppression central frequency	Po241	Reserved
Po242	Vibration suppression intensity		

(1) User Parameter Illustration

A) Position Loop Gain

Po301	1 st position loop gain Position			
	Setting Range	Setting Unit	Mfr's Value	Effect
	1~30000	N/A	—	Effective Immediately
Po302	2 nd position loop gain Position			
	Setting Range	Setting Unit	Mfr's Value	Effect
	1~30000	N/A	—	Effective Immediately

FL20-SA Series

Po303	Position loop feedforward gain Position			
	Setting Range	Setting Unit	Mfr's Value	Effect
	0~1000	N/A	0	Effective Immediately
Po306	Position filter time constant Position			
	Setting Range	Setting Unit	Mfr's Value	Effect
	1~10000	1ms	1	Effective Immediately

Position loop gain decides the responsiveness of position control. The bigger setting value is, the higher gain is, and rigidity is larger. In same frequency instruction pulse, the better following feature of position instruction is, the lower position error is, and the shorter positioning setting time is, but overlarge setting value could cause mechanical shock or position overshoot. Internal servo drive uses feedforward compensation for position control to narrow the positioning time, but the setting value is overlarge, it may cause mechanical vibration.

If position control instruction changes smoothly, increasing gain can reduce the position following error; if it does not change smoothly, lower gain can reduce the vibration of system.

B) Speed Loop Gain

Po101	1 st Speed loop proportional gain speed position torque			
	Setting Range	Setting Unit	Mfr's Value	Effect
	0~30000	0.1Hz	600	Effective Immediately
Po102	1 st Speed loop integral time speed position torque			
	Setting Range	Setting Unit	Mfr's Value	Effect
	0~10000	0.1ms	500	Effective Immediately
Po103	2 nd Speed loop proportional gain speed position torque			
	Setting Range	Setting Unit	Mfr's Value	Effect
	0~30000	0.1Hz	240	Effective Immediately
Po104	2 nd Speed loop integral time speed position torque			
	Setting Range	Setting Unit	Mfr's Value	Effect
	0~30000	0.1ms	1250	Effective Immediately
Po105	1 st Speed loop time constant speedposition			
	Setting Range	Setting Unit	Mfr's Value	Effect
	1~20000	0.1ms	1250	Effective Immediately
Po106	2 nd Speed loop filter time constant speedposition			
	Setting Range	Setting Unit	Mfr's Value	Effect
	1~20000	0.1ms	—	Effective Immediately

Speed loop proportional gain decides the responsiveness of position control. The bigger setting value is, the higher gain is, but oversize setting could cause mechanical resonance. The frequency in speed mode

control is 4~6 times higher than that in position mode control, when position response frequency is higher than speed response frequency, the machinery could shake or position overshoot. When inertia ratio becomes larger, the speed response of control system goes down and becomes unstable. Generally increase the speed loop gain, but when the speed loop gain is overlarge, vibration occurs in running or stop status (abnormal sound), therefore, set the speed loop gain to 50%~80% of gain when vibration. Increase speed response and integral time to reduce the overshoot of accel/dec; reduce integral time can improve the rotation. Reducing speed control integral time can increase speed response and narrow speed control error, but vibration and noise may happen.

Reduce the noises in speed mode and position mode; Increase filter time constant can reduce noise but could slow down the response.

C) Torque Loop Gain

Po200	1 st current loop bandwidth [speed] [position] [torque]			
	Setting Range	Setting Unit	Mfr's Value	Effect
	10~3000	HZ	—	Effective Immediately
Po201	2 nd current loop bandwidth [speed] [position] [torque]			
	Setting Range	Setting Unit	Mfr's Value	Effect
	10~3000	HZ	—	Effective Immediately
Po214	1 st torque filter time constant [speed] [position] [torque]			
	Setting Range	Setting Unit	Mfr's Value	Effect
	0~30000	0.01ms	—	Effective Immediately
Po215	2 nd torque filter time constant [speed] [position] [torque]			
	Setting Range	Setting Unit	Mfr's Value	Effect
	0~30000	0.01ms	—	Effective Immediately

The larger current loop bandwidth is, the faster system response speed is, but the noise may be louder; vice versa.

7.3.4 Gain Switch

Internal status or external DI can trigger gain-switching function, which has effects below:

- Switch to lower gain for vibration inhibition in the idle state of motor (servo enabled);
- Switch to higher gain for narrowing positioning time in the idle state of motor;
- Switch to higher gain for obtaining better instruction tracking performance in the running status of motor;
- Switch different gain setting by external signal according to the condition of loading equipment;

(1) User Parameter

FL20-SA Series

Po130	Gain switching setting			Position	Speed
	Setting Range	Setting Unit	Mfr's Value	Effect	
	0~6	N/A	0	Effective Immediately	

The setting of Po130 can realize the switchover between gain 1 and gain 2 according to different conditions.

Gain 1 includes speed loop proportional gain 1(Po101), speed loop integral time 1(Po102) and position loop proportional gain 1(Po301), first speed loop filter time constant (Po105), torque filter time constant (Po214).

Gain 2 includes speed loop proportional gain 2(Po103), speed loop integral time 2 (Po104) and position loop proportional gain 2(Po302), speed loop filter time constant (Po106), torque filter time constant (Po215).

Parameter	Content
Po130=0	No switch, default to use gain 1
Po130=1	No switch, default to use gain 2
Po130=2	Switch to gain 2 Immediate when speed is higher than the setting value of Po131, if speed is lower than Po131, after delay the setting time of Po135(0.1ms), switch to gain 1.
Po130=3	Switch terminal control, use gain 1 if the switching terminal defined in CN3 is invalid; use gain 2 if valid.
Po130=4	Switch to gain 2 Immediate when position error is higher than the setting value of Po132; If lower than Po131, delay the setting time of Po135 (0.1ms), switch to gain 1.
Po130=5	Switch to gain 2 Immediate if there is pulse input; if there is no pulse input, delay the setting time of Po135(0.1ms), then switch to gain 1.
Po130=6	Switch to gain 2 Immediate if there is pulse input; If there is no pulse input and the speed is lower than Po131, delay the setting time of Po135(0.1ms), then switch to gain 1.

FL20-SA Series

Po131	Position Speed			
	Setting Range	Setting Unit	Mfr's Value	Effect
	1~32000	0.1r/min	100	Effective Immediately
Po132	Gain switching pulse			
	Position Speed			
	Setting Range	Setting Unit	Mfr's Value	Effect
	1~32000	N/A	100	Effective Immediately
Po133	Positon loop gain switching time			
	Position Speed			
	Setting Range	Setting Unit	Mfr's Value	Effect
	1~32000	0.1ms	20	Effective Immediately
	The time from one gain switching to another gain smoothly.			
Po134	Speed loop gain switching time			
	Position Speed			
	Setting Range	Setting Unit	Mfr's Value	Effect
	0~20000	0.1ms	100	Effective Immediately
	The time from one gain switching to another gain smoothly.			
Po135	Gain 2 switch to gain 1 delay time			
	Position Speed			
	Setting Range	Setting Unit	Mfr's Value	Effect
	0~32000	0.1ms	1000	Effective Immediately
	When gain 2 switches to gain 1, delay the time set by Po135, then switch the time according to the setting of Po133.			

7.4 Vibration Inhibition

7.4.1 Vibration Inhibition Function

Mechanical system has certain resonant frequency, when improving servo gain, resonance may generate, which could not make the gain improving continuously. There are 2 main schemes for vibration inhibition:

1) Torque Instruction Filter(Po214 and Po215)

Torque instruction decays in high frequency by setting filter time constant to realize vibration inhibition.

2) Notch Filter

Notch filter can lower the gain of certain frequency to reach vibration inhibition.

The principle of notch filter shows as below:

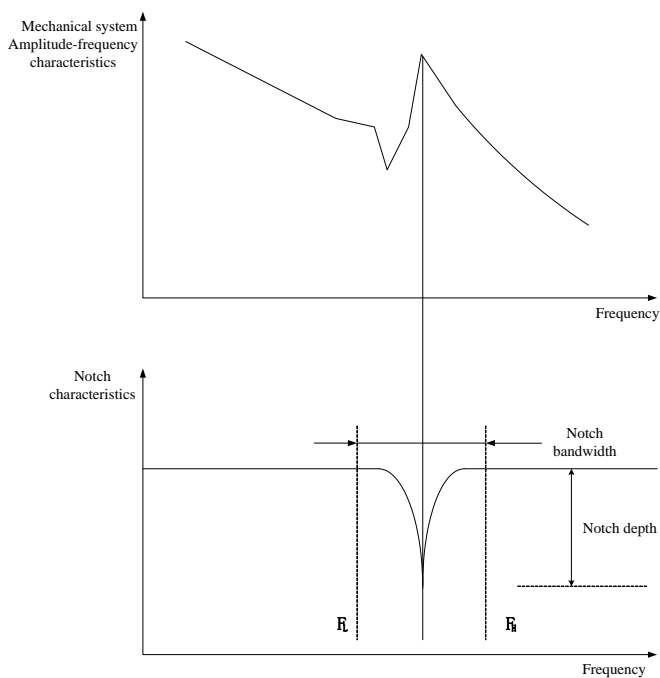

Fig 7.4.1 Inhibition principle of notch filter

Servo drive has 4 groups of notch filters; each notch filter has 3 parameters, which are notch filter frequency, width level and depth level. Four notch filters either can be set manually or can be configured as adaptive notch filter, at this time each parameter is set by servo drive.

Object	1 st Notch Filter	2 nd Notch Filter	3 rd Notch Filter	4 th Notch Filter
Frequency	Po217	Po220	Po223	Po226
Width level	Po218	Po221	Po224	Po227

Depth level	Po219	Po222	Po225	Po228
--------------------	--------------	--------------	--------------	--------------

7.4.2 Low-frequency Vibration Inhibition Function

If the mechanical load end is long and heavy, end is likely to vibrate when emergency stop to influence positioning. The frequency of this kind of vibration is within 100Hz generally, which is lower than the mechanical resonance frequency introduced in chapter 7.4.1, so is called low-frequency resonance. It can reduce the frequency effectively by the function of low-frequency vibration inhibition.

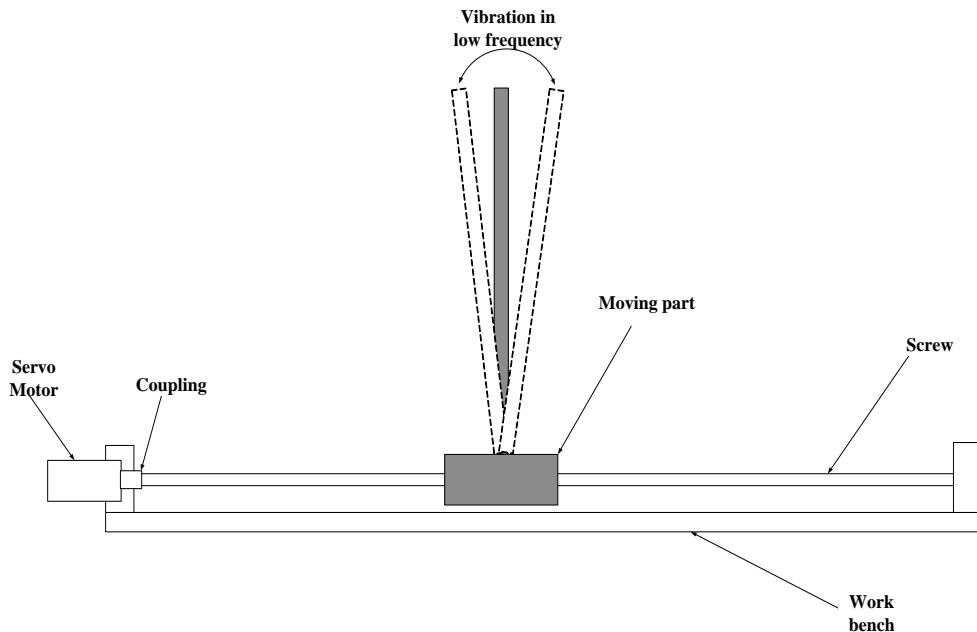

Fig 7.4.2 Low frequency resonance sketch map

(1) User Parameter

Po240	Vibration suppression central frequency Position			
	Setting Range	Setting Unit	Mfr's Value	Effect
	50~2000	0.1Hz	2000	Effective Immediately
Po242	Vibration suppression intensity Position			
	Setting Range	Setting Unit	Mfr's Value	Effect
	0~100	N/A	0	Effective Immediately

VIII List of parameters

No.	Group name	Group shorten name	Function code range	Descriptions
1	Monitor function group	L group	Lo-00~Lo-35	Monitor servo present status.
2	Utility function group	S group	So-00~So-62	Set the utility function.
3	Main function group	P group	Po000~Po049	Parameters related to system.
			Po100~Po149	Parameters related to speed loop.
			Po200~Po249	Parameters related to torque loop.
			Po300~Po399	Parameters related to position loop.
			Po400~Po449	Parameters related to terminals.
Po500~Po549	Parameters related to communication.			
4	Motor parameter	H group	Ho000~ Ho049	Parameters related to motor
5	Alarm record parameters	H group	Ho300~ Ho330	Parameters related to alarm
6	High-speed counter parameters	PL group	PL000~PL199	Parameters related to high-speed counter

Instruction for parameters list:

- (1) Instruction of parameter name

When the parameter is “reserved”, please do not set this kind of parameters.

- (2) Instruction of parameter units

The units of function selection parameters are N/A, they are no units.

- (3) Instruction of control mode

The scopes of parameters are all servo running modes.

- (4) Instruction of Mfr’s value

The Mfr’s value of parameter is “—”, it indicates that this parameter is related to the characteristic of matching servo motor. If servo motors are different, the parameters are different.

The user must enter correct user’s password if you intend to change parameters. Otherwise, parameters can not be modified, and Err will be displayed.

8.1.1 Monitor function group (Lo-□□)

The monitor mode can be used for monitoring the command value and servodrive internal status.

Parameter	Display content	Unit	Remark
Lo-00	Servodrive output current	0.1A	
Lo-01	Servodrive bus voltage	V	
Lo-02	Servo motor rotation speed	0.1r/min	
Lo-03	Servo motor feedback pulse displays high 5 digits.	10000	
Lo-04	Servo motor feedback pulse displays low 5 digits	Command unit	

FL20-SA Series

Lo-05	Servo motor feedback rotation displays high 5 digits	10000	
Lo-06	Servo motor feedback rotation displays low 5 digits	Command unit	
Lo-07	Given command pulse numbers display high 5 digits	Command unit	Valid in position pulse mode.
Lo-08	Given command pulse numbers display low 5 digits	Command unit	Valid in position pulse mode.
Lo-09	Command pulse error numbers	Command unit	Valid in position pulse mode.
Lo-10	Given speed	0.1r/min	Valid in speed mode.
Lo-11	Given torque	1% of rated torque	Valid in torque mode.
Lo-12	Analog speed command display	0.1r/min	Valid in analog speed mode.
Lo-13	Analog torque command display	1% of rated torque	Valid in analog torque mode.
Lo-14	DI8~DI5 status display	None	

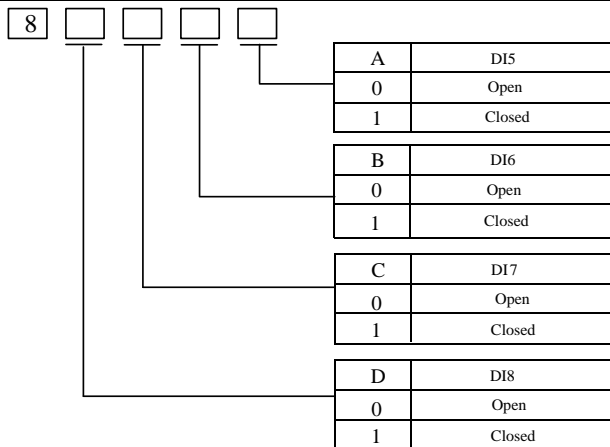

Lo-15	DI4~DI1 status display	None	
-------	------------------------	------	--

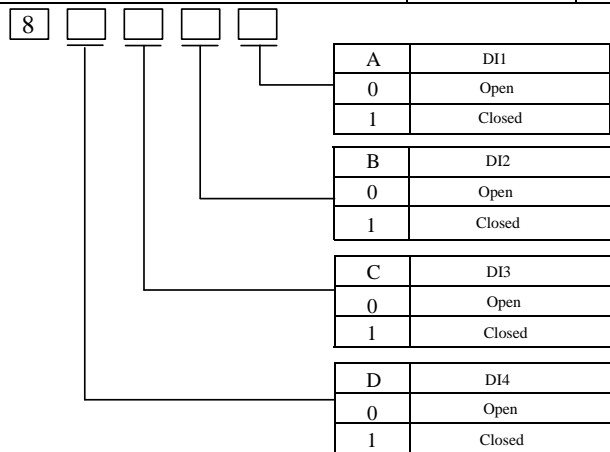

FL20-SA Series

Lo-16	The other output interface status display.	None																															
<table border="1" style="margin-left: auto; margin-right: auto;"> <tr><td style="width: 20px;">A</td><td>ALM</td></tr> <tr><td>0</td><td>Open</td></tr> <tr><td>1</td><td>Closed</td></tr> <tr><td colspan="2"> </td></tr> <tr><td>B</td><td>ALO1</td></tr> <tr><td>0</td><td>Open</td></tr> <tr><td>1</td><td>Closed</td></tr> <tr><td colspan="2"> </td></tr> <tr><td>C</td><td>ALO2</td></tr> <tr><td>0</td><td>Open</td></tr> <tr><td>1</td><td>Closed</td></tr> <tr><td colspan="2"> </td></tr> <tr><td>D</td><td>ALO3</td></tr> <tr><td>0</td><td>Open</td></tr> <tr><td>1</td><td>Closed</td></tr> </table>				A	ALM	0	Open	1	Closed			B	ALO1	0	Open	1	Closed			C	ALO2	0	Open	1	Closed			D	ALO3	0	Open	1	Closed
A	ALM																																
0	Open																																
1	Closed																																
B	ALO1																																
0	Open																																
1	Closed																																
C	ALO2																																
0	Open																																
1	Closed																																
D	ALO3																																
0	Open																																
1	Closed																																
Lo-17	DO4~DO1 status display	None																															
<table border="1" style="margin-left: auto; margin-right: auto;"> <tr><td style="width: 20px;">A</td><td>DO1</td></tr> <tr><td>0</td><td>Open</td></tr> <tr><td>1</td><td>Closed</td></tr> <tr><td colspan="2"> </td></tr> <tr><td>B</td><td>DO2</td></tr> <tr><td>0</td><td>Open</td></tr> <tr><td>1</td><td>Closed</td></tr> <tr><td colspan="2"> </td></tr> <tr><td>C</td><td>DO3</td></tr> <tr><td>0</td><td>Open</td></tr> <tr><td>1</td><td>Closed</td></tr> <tr><td colspan="2"> </td></tr> <tr><td>D</td><td>DO4</td></tr> <tr><td>0</td><td>Open</td></tr> <tr><td>1</td><td>Closed</td></tr> </table>				A	DO1	0	Open	1	Closed			B	DO2	0	Open	1	Closed			C	DO3	0	Open	1	Closed			D	DO4	0	Open	1	Closed
A	DO1																																
0	Open																																
1	Closed																																
B	DO2																																
0	Open																																
1	Closed																																
C	DO3																																
0	Open																																
1	Closed																																
D	DO4																																
0	Open																																
1	Closed																																
Lo-18	Current temperature display of servo drive	°C																															
Lo-19	Rotation inertia display	0.01																															
Lo-20	Current output torque display	%																															
Lo-21	Current gain group display	N/A																															
Lo-22	Braking power display	10ms																															
Lo-23	One-loop pulse high 5 digits of motor absolute position	100000																															
Lo-24	One-loop pulse low 5 digits of motor absolute position	Command unit																															
Lo-25	Multi-loop pulse high 5 digits of motor absolute position	100000																															
Lo-26	Multi-loop pulse low 5 digits of motor absolute position	Command unit																															

FL20-SA Series

Lo-27	AI1 voltage	10mv	
Lo-28	AI2 voltage	10mv	
Lo-29	Mix error	Command unit	
Lo-30	Full closed-loop feedback pulse numbers		
Lo-31	Gantry sync error pulse numbers		
Lo-32	Reserved		
Lo-33	Pulse numbers of high-speed counter 1	Command unit	
Lo-34	Pulse numbers of high-speed counter 2	Command unit	
Lo-36	Temperature of motor	°C	

Note: This group of parameters can only be checked, not be set.

8.1.2 Utility function group (So-□□)

So-00	Software version Speed Position Torque			
	Setting range	Setting unit	Mfr's value	Effect
	N/A	N/A	—	—
So-00 is software version of FL20 series servo drive. For example, if 100 is displayed, software version is 1.00.				
So-01	User's password (Avoid modifying parameters by mistake) Speed Position Torque			
	Setting range	Setting unit	Mfr's value	Effect
	0~9999	N/A	0	Re-power on
Setting password is used to avoid modifying parameters by mistake. The Mfr's value is 0, which means password is invalid and users can modify parameters anytime. If users want to use this function, please set a password for this parameter and restart servo, then this function is valid. Most auxiliary function and main function parameters except monitor function parameters can be modified when the password is input into this parameter. Or else Err will display.				
So-02	Delay time for servo OFF Speed Position Torque			
	Setting range	Setting unit	Mfr's value	Effect
	0~500	10ms	0	Effective Immediately
When braking motor is used, So-02 is delay time before servo drive is enabled. Please refer to 6.1.3 for details				
So-03	Delay time for electro-magnetic braking OFF Speed Position Torque			
	Setting range	Setting unit	Mfr's value	Effect
	10~100	10ms	50	Effective Immediately
When braking motor is used, So-03 is delay time for electro- magnetic braking OFF. Please refer to 6.1.3 for details.				

FL20-SA Series

So-04	Braking resistor value Speed Position Torque			
	Setting range	Setting unit	Mfr's value	Effect
	8~1000	Ω	—	Effective Immediately
So-04 is used to set external braking resistor value. External braking resistor can not be used with internal braking resistor at the same time. Before connecting to external resistor, please remove jumper between B2 and B3, then connect resistor to B1 and B2 terminal. Please refer to 6.1.7 for details.				
So-05	Discharge duty ratio Speed Position Torque			
	Setting range	Setting unit	Mfr's value	Effect
	0~100	%	50	Effective Immediately
So-05 is used to set discharge duty ratio. The higher the duty ratio, the faster discharge speed.				
So-06	Input power phase-loss protection Speed Position Torque			
	Setting range	Setting unit	Mfr's value	Effect
	0~1	N/A	—	Effective Immediately
0: phase-loss protection is invalid; 1: phase-loss protection is valid				
So-07	Servo OFF stop mode Speed Position Torque			
	Setting range	Setting unit	Mfr's value	Effect
	0~2	N/A	0	Effective Immediately
0: Free stop 1: Dynamic brake. This function is valid only when servo drive has dynamic brake. 2: Fast enabled. For fast enable requirement, after power on servo drive 10 ms, servo drive is enabled.				
So-08	Delay time of dynamic braking Speed Position Torque			
	Setting range	Setting unit	Mfr's value	Effect
	100~30000	0.1ms	5000	Effective Immediately
So-09	Servo drive display items Speed Position Torque			
	Setting range	Setting unit	Mfr's value	Effect
	0~37	N/A	2	Effective Immediately

FL20-SA Series

Setting value	Definition	Setting value	Definition
0	Servo drive output current	19	Rotating inertia display
1	Servo drive bus voltage	20	Output torque display
2	Servo motor rotating speed	21	Current gain group
3	Servo motor feedback pulse displays high 5 digits.	22	Discharge time
4	Servo motor feedback pulse displays low 5 digits.	23	Encoder absolute position high digit pulse
5	Servo motor feedback rotation displays high 5 digits.	24	Encoder absolute position low digit pulse
6	Servo motor feedback rotation displays low 5 digits.	25	High 5 digits of number of turns of encoder absolute position
7	Given command pulse numbers display high 5 digits.	26	Low 5 digits of number of turns of encoder absolute position
8	Given command pulse numbers display low 5 digits.	27	AI1 voltage
9	Given command pulse error numbers	28	AI2 voltage
10	Given speed	29	Combined deviation
11	Given torque	30	Close-loop feedback
12	Analog speed command display	31	Gantry synchronous deviation
13	Analog torque command display	32	Reserved
14	D18~D15 status display	33	High-speed counter 1
15	D14~D11 status display	34	High-speed counter 2
16	Other output interface status display	35	PLC monitor
17	D4~D1 status display	36	Motor temperature
18	Drive current temperature display	37	Motor shaft position
So-10	Record of the latest malfunction type Speed Position Torque		
	Setting range	Setting unit	Mfr's value
	N/A	N/A	—
So-10 can only be checked, not be modified.			
So-11	Record of malfunction type for last but one Speed Position Torque		
	Setting range	Setting unit	Mfr's value
	N/A	N/A	—

FL20-SA Series

So-12	Record of malfunction type for two but one Speed Position Torque			
	Setting range	Setting unit	Mfr's value	Effect
	N/A	N/A	—	—
So-13	JOG speed Speed Position Torque			
	Setting range	Setting unit	Mfr's value	Effect
	0~30000	0.1r/min	1000	Effective Immediately
So-14	JOG run Speed Position Torque			
	Setting range	Setting unit	Mfr's value	Effect
	—	—	—	Effective Immediately
So-15	Encoder disconnection protection Speed Position Torque			
	Setting range	Setting unit	Mfr's value	Effect
	0~1	N/A	1	Effective Immediately
0: close protection; 1:open protection				
So-16	Speed threshold of electromagnetic brake Speed Position Torque			
	Setting range	Setting unit	Mfr's value	Effect
	0~30000	0.1r/min	1000	Effective Immediately
When brake motor is used, So-16 is used to set speed threshold of electromagnetic brake. Refer to 6.1.3 for details.				
So-17	Forward run prohibited Speed Position Torque			
	Setting range	Setting unit	Mfr's value	Effect
	0~1	N/A	1	Effective Immediately
0: Invalid; 1:Valid When So-17=1, So-18=1 and external control terminals with the function of F-INH and R-INH are allocated, the overtravel function is enabled. For security, the default setting of So-17 and So-18 are prohibited valid and the signal input type is common-close contact. So even malfunction occurs, the overtravel protection is still valid.				
So-18	Reverse run prohibited Speed Position Torque			
	Setting range	Setting unit	Mfr's value	Effect
	0~1	N/A	1	Effective Immediately
0: Invalid; 1:Valid Refer to So-17.				
So-19	Analog monitor channel 1 Speed Position Torque			
	Setting range	Setting unit	Mfr's value	Effect
	0~3	N/A	0	Effective Immediately

FL20-SA Series

Please refer to 6.2.5 for details.

Parameter setting	Output analog contents	Remarks
So-19=0	Servo drive output current	Servodrive output current corresponding to 10V is controlled by So-20.
So-19=1	Servo drive bus voltage	Servodrive max bus line voltage corresponding to 10V is controlled by So-21.
So-19=2	Servo motor rotation speed	Servo motor rotation speed corresponding to 10V is controlled by So-22.
So-19=3	Output voltage 0V + offset	

So-20	Servodrive output current corresponding to 10V Speed Position Torque			
	Setting range	Setting unit	Mfr's value	Effect
	1~1000	0.1A	200	Effective Immediately
So-21	Servodrive max bus line voltage corresponding to 10V Speed Position Torque			
	Setting range	Setting unit	Mfr's value	Effect
	1~500	1V	500	Effective Immediately
So-22	Max rotation speed corresponding to 10V Speed Position Torque			
	Setting range	Setting unit	Mfr's value	Effect
	1~32000	0.1r/min	30000	Effective Immediately
So-24	Analog monitor voltage compensation 1 Speed Position Torque			
	Setting range	Setting unit	Mfr's value	Effect
	-10000~+1000	mv	0	Effective Immediately
So-25	Electric angle identification Speed Position Torque			
	Setting range	Setting unit	Mfr's value	Effect
	0~10	N/A	0	Effective Immediately

Please refer to the chapter 6.

So-26	Control mode of fan Speed Position Torque			
	Setting range	Setting unit	Mfr's value	Effect
	0~2	N/A	2	Effective Immediately

So-26 is available for 15kw and above 15kw servo drive.

0: Fan is controlled by temperature.

L: As long as power on, fan starts to run.

2: As long as servo drive runs, fan starts to run..

FL20-SA Series

So-27	Fan temperature setting Speed Position Torque												
	Setting range	Setting unit	Mfr's value	Effect									
	10~100	°C	45	Effective Immediately									
So-28	Power-off brake Speed Position Torque												
	Setting range	Setting unit	Mfr's value	Effect									
	0~1	N/A	1	Effective Immediately									
0:invalid 1:valid													
So-29	Power-off brake time Speed Position Torque												
	Setting range	Setting unit	Mfr's value	Effect									
	500~30000	0.1ms	1000	Effective Immediately									
So-30	Setting of absolute position and relative position Speed Position Torque												
	Setting range	Setting unit	Mfr's value	Effect									
	0~1	N/A	1	Effective Immediately									
<table border="1" style="width:100%; border-collapse: collapse;"> <thead> <tr> <th style="width:15%;">Setting value</th> <th style="width:20%;">Definition</th> <th style="width:65%;">Remarks</th> </tr> </thead> <tbody> <tr> <td style="text-align:center;">0</td> <td>Absolute position</td> <td>In internal position absolute mode, encoder feedback absolute position is adopted.</td> </tr> <tr> <td style="text-align:center;">1</td> <td>Relative position</td> <td>Battery protection is shielded, in internal position absolute mode, encoder feedback absolute position isn't adopted..</td> </tr> </tbody> </table>					Setting value	Definition	Remarks	0	Absolute position	In internal position absolute mode, encoder feedback absolute position is adopted.	1	Relative position	Battery protection is shielded, in internal position absolute mode, encoder feedback absolute position isn't adopted..
Setting value	Definition	Remarks											
0	Absolute position	In internal position absolute mode, encoder feedback absolute position is adopted.											
1	Relative position	Battery protection is shielded, in internal position absolute mode, encoder feedback absolute position isn't adopted..											
So-32	Grounding protection Speed Position Torque												
	Setting range	Setting unit	Mfr's value	Effect									
	0~1	N/A	0	Effective Immediately									
0: invalid 1:valid													
So-34	Motor lock-rotor protection Speed Position Torque												
	Setting range	Setting unit	Mfr's value	Effect									
	0~1	N/A	1	Effective Immediately									
0: invalid 1:valid													
So-35	Overload pre-alarm current Speed Position Torque												
	Setting range	Setting unit	Mfr's value	Effect									
	0~800	%	120	Effective Immediately									
So-36	Overload pre-alarm filter time Speed Position Torque												
	Setting range	Setting unit	Mfr's value	Effect									
	0~1000	10ms	10	Effective Immediately									

FL20-SA Series

So-37	Motor overload coefficient setting			Speed	Position	Torque
	Setting range	Setting unit	Mfr's value	Effect		
	1~500	%	100	Effective Immediately		
Please refer to 6.6.2 for details.						
So-38	Under voltage protection of LI battery			Speed	Position	Torque
	Setting range	Setting unit	Mfr's value	Effect		
	0~1	N/A	1	Effective Immediately		
0: invalid 1:valid						
So-39	Overtravel limit function			Speed	Position	Torque
	Setting range	Setting unit	Mfr's value	Effect		
	0~2	N/A	1	Effective Immediately		
0: invalid 1:valid						
So-40	Delay time of lock-rotor protection			Speed	Position	Torque
	Setting range	Setting unit	Mfr's value	Effect		
	10~1000	10ms	100	Effective Immediately		
So-41	Setting mechanical origin			Speed	Position	Torque
	Setting range	Setting unit	Mfr's value	Effect		
	0~1	N/A	0	Effective Immediately		
0: invalid 1:valid						
So-42	Alarm output duty ratio			Speed	Position	Torque
	Setting range	Setting unit	Mfr's value	Effect		
	1~100	%	100	Effective Immediately		
So-43	Encoder reset			Speed	Position	Torque
	Setting range	Setting unit	Mfr's value	Effect		
	0~1	N/A	0	Effective Immediately		
0: invalid 1:valid						
So-43 is used to reset motor encoder when encoder alarm occurs. User must hold down SET key to reset keypad panel.						
So-44	Paramter copy			Speed	Position	Torque
	Setting range	Setting unit	Mfr's value	Effect		
	Four- parameter	N/A	0000	Effective Immediately		

<div style="display: flex; align-items: center;"> <div style="margin-right: 10px;">b) <input type="checkbox"/> <input type="checkbox"/> <input type="checkbox"/> <input type="checkbox"/></div> <table border="1" style="border-collapse: collapse;"> <tr><td>A</td><td>Copy function</td></tr> <tr><td>0</td><td>Invalid</td></tr> <tr><td>1</td><td>Valid</td></tr> </table> <table border="1" style="border-collapse: collapse;"> <tr><td>B</td><td>Copy motor parameter</td></tr> <tr><td>0</td><td>Invalid</td></tr> <tr><td>1</td><td>Valid</td></tr> </table> <table border="1" style="border-collapse: collapse;"> <tr><td>C</td><td>Copy gain parameter</td></tr> <tr><td>0</td><td>Invalid</td></tr> <tr><td>1</td><td>Valid</td></tr> </table> <table border="1" style="border-collapse: collapse;"> <tr><td>D</td><td>Copy notch filter parameter</td></tr> <tr><td>0</td><td>Invalid</td></tr> <tr><td>1</td><td>Valid</td></tr> </table> </div>					A	Copy function	0	Invalid	1	Valid	B	Copy motor parameter	0	Invalid	1	Valid	C	Copy gain parameter	0	Invalid	1	Valid	D	Copy notch filter parameter	0	Invalid	1	Valid
A	Copy function																											
0	Invalid																											
1	Valid																											
B	Copy motor parameter																											
0	Invalid																											
1	Valid																											
C	Copy gain parameter																											
0	Invalid																											
1	Valid																											
D	Copy notch filter parameter																											
0	Invalid																											
1	Valid																											
So-46	FPGA software version <input type="checkbox"/>Speed <input type="checkbox"/>Position <input type="checkbox"/>Torque																											
	Setting range	Setting unit	Mfr's value	Effect																								
	—	N/A	—	Effective Immediately																								
Display 100 means version 1.00																												
So-48	Password for motor parameter <input type="checkbox"/>Speed <input type="checkbox"/>Position <input type="checkbox"/>Torque																											
	Setting range	Setting unit	Mfr's value	Effect																								
	0~9999	N/A	0	Effective Immediately																								
When So-48 is 1, motor parameter can be set.																												
So-49	Revert to Mfr's value <input type="checkbox"/>Speed <input type="checkbox"/>Position <input type="checkbox"/>Torque																											
	Setting range	Setting unit	Mfr's value	Effect																								
	0~1	N/A	0	Repower on																								
<p>0: invalid 1:valid</p> <p>When there is disorder with parameters and Mfr's value need to be restored, set So-49=1. The procedure is to set So-49=1 and press SET key for 0.5s, wait for 5 seconds, then power down and repower on, all parameters will revert to Mfr's value.</p> <p> When servo drive is enabled, revert to Mfr's value is invalid.</p>																												
So-50	Motor overheat protection <input type="checkbox"/>Speed <input type="checkbox"/>Position <input type="checkbox"/>Torque																											
	Setting range	Setting unit	Mfr's value	Effect																								
	0~1	N/A	0	Effective Immediately																								
0: invalid 1:valid																												
So-51	Motor disconnected protection of temperature detection <input type="checkbox"/>Speed <input type="checkbox"/>Position <input type="checkbox"/>Torque																											
	Setting range	Setting unit	Mfr's value	Effect																								
	0~1	N/A	1	Effective Immediately																								

FL20-SA Series

0: invalid 1: valid																			
So-52	Encoder pulse filtering coefficient [speed] [position] [torque]																		
	Setting range	Setting unit	Mfr's value	Effect															
	0~1000	N/A	0	Effective Immediately															
When So-52≠0, the signal level which duration time is lower than (So-52/30MHz)s will be filtered.																			
So-54	Torque unreached protection setting [speed] [position] [torque]																		
	Setting range	Setting unit	Mfr's value	When enabled															
	0~1	N/A	1	Effective Immediately															
So-55	Torque unreached time [speed] [position] [torque]																		
	Setting range	Setting unit	Mfr's value	When enabled															
	1~100	10ms	10	Effective Immediately															
So-61	Analog monitor channel 2 [Speed] [Position] [Torque]																		
	Setting range	Setting unit	Mfr's value	Effect															
	0~3	N/A	0	Effective Immediately															
<table border="1" style="width: 100%; border-collapse: collapse;"> <thead> <tr> <th style="text-align: center;">Setting value</th> <th style="text-align: center;">Definition</th> <th style="text-align: center;">Remarks</th> </tr> </thead> <tbody> <tr> <td style="text-align: center;">0</td> <td style="text-align: center;">Servo drive output current</td> <td style="text-align: center;">Determined by So-20</td> </tr> <tr> <td style="text-align: center;">1</td> <td style="text-align: center;">Servo drive output voltage</td> <td style="text-align: center;">Determined by So-21</td> </tr> <tr> <td style="text-align: center;">2</td> <td style="text-align: center;">Servo motor speed</td> <td style="text-align: center;">Determined by So-22</td> </tr> <tr> <td style="text-align: center;">3</td> <td style="text-align: center;">Output voltage 0V + offset</td> <td style="text-align: center;">Offset voltage is determined by So-62.</td> </tr> </tbody> </table>					Setting value	Definition	Remarks	0	Servo drive output current	Determined by So-20	1	Servo drive output voltage	Determined by So-21	2	Servo motor speed	Determined by So-22	3	Output voltage 0V + offset	Offset voltage is determined by So-62.
Setting value	Definition	Remarks																	
0	Servo drive output current	Determined by So-20																	
1	Servo drive output voltage	Determined by So-21																	
2	Servo motor speed	Determined by So-22																	
3	Output voltage 0V + offset	Offset voltage is determined by So-62.																	
So-62	Voltage compensation for Analog monitor channel 2 [Speed] [Position] [Torque]																		
	Setting range	Setting unit	Mfr's value	Effect															
	-10000~10000	mv	0	Effective Immediately															

8.1.3 Main function group (Po-□□□)

Po000	Motor code [Speed] [Position] [Torque]			
	Setting range	Setting unit	Mfr's value	Effect
	—	N/A	—	—
Po000 is motor code, user can check motor parameter by Po000.				

FL20-SA Series

Po001	Setting of Control mode and rotary direction				<input type="checkbox"/> Speed	<input type="checkbox"/> Position	<input type="checkbox"/> Torque																																																						
	Setting range	Setting unit	Mfr's value	Effect																																																									
	Two-parameter	N/A	11	Repower on																																																									
<div style="display: flex; align-items: center; margin-bottom: 10px;"> d </div> <table border="1" style="width: 100%; border-collapse: collapse;"> <tr> <td style="width: 5%; text-align: center;">X</td> <td>Control mode setting</td> </tr> <tr><td style="text-align: center;">0</td><td>Internal register speed mode</td></tr> <tr><td style="text-align: center;">1</td><td>Position pulse mode</td></tr> <tr><td style="text-align: center;">2</td><td>Internal register torque mode</td></tr> <tr><td style="text-align: center;">3</td><td>Analog speed mode</td></tr> <tr><td style="text-align: center;">4</td><td>Analog torque mode</td></tr> <tr><td style="text-align: center;">5</td><td>Internal register position mode</td></tr> <tr><td style="text-align: center;">6</td><td>Mix mode of internal register speed and position pulse</td></tr> <tr><td style="text-align: center;">7</td><td>Mix mode of internal register speed and internal register torque</td></tr> <tr><td style="text-align: center;">8</td><td>Mix mode of internal register speed and analog speed</td></tr> <tr><td style="text-align: center;">9</td><td>Mix mode of internal register speed and analog torque</td></tr> <tr><td style="text-align: center;">10</td><td>Mix mode of internal register speed and internal register position</td></tr> <tr><td style="text-align: center;">11</td><td>Mix mode of internal register torque and position pulse</td></tr> <tr><td style="text-align: center;">12</td><td>Mix mode of analog speed and position pulse</td></tr> <tr><td style="text-align: center;">13</td><td>Mix mode of analog torque and position pulse</td></tr> <tr><td style="text-align: center;">14</td><td>Mix mode of position pulse and internal register position</td></tr> <tr><td style="text-align: center;">15</td><td>Mix mode of analog speed and internal register torque</td></tr> <tr><td style="text-align: center;">16</td><td>Mix mode of analog torque and internal register torque</td></tr> <tr><td style="text-align: center;">17</td><td>Mix mode of register torque and internal register position</td></tr> <tr><td style="text-align: center;">18</td><td>Mix mode of analog speed and analog torque</td></tr> <tr><td style="text-align: center;">19</td><td>Mix mode of analog speed and internal register position</td></tr> <tr><td style="text-align: center;">20</td><td>Mix mode of analog torque and internal register position</td></tr> <tr><td style="text-align: center;">21</td><td>Bus control mode</td></tr> <tr><td style="text-align: center;">22</td><td>Built-in PLC control mode</td></tr> <tr> <td style="text-align: center;">Y</td> <td>Motor forward direction</td> </tr> <tr><td style="text-align: center;">0</td><td>Clockwise as viewed from the servo motor shaft</td></tr> <tr><td style="text-align: center;">1</td><td>Counterclockwise as viewed from the servo motor shaft</td></tr> </table>								X	Control mode setting	0	Internal register speed mode	1	Position pulse mode	2	Internal register torque mode	3	Analog speed mode	4	Analog torque mode	5	Internal register position mode	6	Mix mode of internal register speed and position pulse	7	Mix mode of internal register speed and internal register torque	8	Mix mode of internal register speed and analog speed	9	Mix mode of internal register speed and analog torque	10	Mix mode of internal register speed and internal register position	11	Mix mode of internal register torque and position pulse	12	Mix mode of analog speed and position pulse	13	Mix mode of analog torque and position pulse	14	Mix mode of position pulse and internal register position	15	Mix mode of analog speed and internal register torque	16	Mix mode of analog torque and internal register torque	17	Mix mode of register torque and internal register position	18	Mix mode of analog speed and analog torque	19	Mix mode of analog speed and internal register position	20	Mix mode of analog torque and internal register position	21	Bus control mode	22	Built-in PLC control mode	Y	Motor forward direction	0	Clockwise as viewed from the servo motor shaft	1	Counterclockwise as viewed from the servo motor shaft
X	Control mode setting																																																												
0	Internal register speed mode																																																												
1	Position pulse mode																																																												
2	Internal register torque mode																																																												
3	Analog speed mode																																																												
4	Analog torque mode																																																												
5	Internal register position mode																																																												
6	Mix mode of internal register speed and position pulse																																																												
7	Mix mode of internal register speed and internal register torque																																																												
8	Mix mode of internal register speed and analog speed																																																												
9	Mix mode of internal register speed and analog torque																																																												
10	Mix mode of internal register speed and internal register position																																																												
11	Mix mode of internal register torque and position pulse																																																												
12	Mix mode of analog speed and position pulse																																																												
13	Mix mode of analog torque and position pulse																																																												
14	Mix mode of position pulse and internal register position																																																												
15	Mix mode of analog speed and internal register torque																																																												
16	Mix mode of analog torque and internal register torque																																																												
17	Mix mode of register torque and internal register position																																																												
18	Mix mode of analog speed and analog torque																																																												
19	Mix mode of analog speed and internal register position																																																												
20	Mix mode of analog torque and internal register position																																																												
21	Bus control mode																																																												
22	Built-in PLC control mode																																																												
Y	Motor forward direction																																																												
0	Clockwise as viewed from the servo motor shaft																																																												
1	Counterclockwise as viewed from the servo motor shaft																																																												
Po002	Max speed (Absolute value)				<input type="checkbox"/> Speed	<input type="checkbox"/> Position	<input type="checkbox"/> Torque																																																						
	Setting range	Setting unit	Mfr's value	Effect																																																									
	0~10000	r/min	—	Effective Immediately																																																									
Po002 is motor max speed limit, which is valid for forward and reverse running.																																																													
Po003	Numerator of frequency-division number of Encoder pulse				<input type="checkbox"/> Speed	<input type="checkbox"/> Position	<input type="checkbox"/> Torque																																																						

FL20-SA Series

	Setting range	Setting unit	Mfr's value	Effect
	1~65535	N/A	—	Effective Immediately
Encoder frequency-division number for each phase is set by Po003.				
Po004	Servo-on mode			<input type="checkbox"/> Speed <input type="checkbox"/> Position <input type="checkbox"/> Torque
	Setting range	Setting unit	Mfr's value	Effect
	0~1	N/A	0	Repower on
0: External terminal enabled, there must be input terminal, which is set SON-I function. 1: Internal parameter enabled, which is determined by Po100.				
Po005	Denominator of frequency-division number of Encoder pulse			<input type="checkbox"/> Speed <input type="checkbox"/> Position <input type="checkbox"/> Torque
	Setting range	Setting unit	Mfr's value	Effect
	1~2147483647	N/A	—	Effective Immediately
Po007	Change rate of load inertia			<input type="checkbox"/> Speed <input type="checkbox"/> Position <input type="checkbox"/> Torque
	Setting range	Setting unit	Mfr's value	Effect
	1~100	N/A	10	Effective Immediately
Po008	Rotary inertia mode			<input type="checkbox"/> Speed <input type="checkbox"/> Position <input type="checkbox"/> Torque
	Setting range	Setting unit	Mfr's value	Effect
	0~3	N/A	0	Effective Immediately
0: Rotary inertia identification is invalid 1: Off-line forward/reverse identification 2: Off-line single-direction identification 3: On-line inertia auto-identification. Inverter keeps in on-line auto-identification, if inverter is jog running, keypad will display rotary inertia, not 'JOG'.				
Po009	Interval time of off-line rotary inertia identification			<input type="checkbox"/> Speed <input type="checkbox"/> Position <input type="checkbox"/> Torque
	Setting range	Setting unit	Mfr's value	Effect
	10~2000	ms	100	Effective Immediately
Po010	Rigidity selection			<input type="checkbox"/> Speed <input type="checkbox"/> Position <input type="checkbox"/> Torque
	Setting range	Setting unit	Mfr's value	Effect
	1~30	N/A	6	Effective Immediately

FL20-SA Series

Rigidity rank Po010	1 st position loop gain Po301	speed loop proportional gain 1 Po101	speed loop integral time1 Po102	1 st speed loop filter time constant Po105	1 st current loop bandwidth Po200	1 st torque filter time constant Po214	Corresponding servo response speed	corresponding mechanical connection
1	384	100	5000	3200	1000	0	slow ↓ medium ↓ fast	Synchronous belt drive, chain drive, wave gear reducer etc ↓ Ball screw controlled by reducer or big size machinery connected to ball (for example: normal working machine, moving machine) ↓ Ball screw directly connected machinery (High-precision processing machinery such as machine tools, etc.)
2	769	200	2500	1668	1000	0		
3	1154	300	1666	1100	1000	0		
4	1538	400	1250	830	1000	0		
5	1923	500	1000	650	1000	0		
6	2423	630	793	529	1000	0		
7	2885	750	666	440	1000	0		
8	3346	870	574	383	1000	0		
9	3846	1000	500	330	1000	0		
10	4308	1120	446	297	1000	0		
11	4808	1250	400	260	1000	0		
12	5270	1370	364	243	1000	0		
13	5770	1500	333	220	1000	0		
14	6231	1620	308	205	1000	0		
15	6731	1750	285	190	1000	0		
16	7193	1870	267	178	1000	0		
17	7693	2000	250	160	1000	0		
18	8193	2130	234	156	1000	0		
19	8655	2250	222	148	1000	0		
20	9617	2500	200	130	1000	0		
21	10578	2750	181	121	1000	0		
22	11540	3000	166	110	1000	0		
23	12502	3250	153	102	1000	0		
24	13463	3500	142	95	1000	0		
25	14425	3750	133	88	1000	0		
26	15387	4000	125	83	1000	0		
27	16349	4250	117	78	1000	0		
28	17310	4500	111	74	1000	0		
29	18272	4750	105	70	1000	0		
30	19234	5000	100	66	1000	0		

FL20-SA Series

Po013	Rotary inertia ratio Speed Position Torque																													
	Setting range	Setting unit	Mfr's value	Effect																										
	1~30000	0.01	200	Effective Immediately																										
Please refer to 7.3																														
Po014	Motion trail accel/decel time Speed Position Torque																													
	Setting range	Setting unit	Mfr's value	Effect																										
	200~5000	ms	1000	Effective Immediately																										
Please refer to 7.3																														
Po015	Motion range of off-line rotary inertia identification Speed Position Torque																													
	Setting range	Setting unit	Mfr's value	Effect																										
	200~2147483647	N/A	—	Effective Immediately																										
Please refer to 7.3																														
Po017	Z pulse frequency-division output width Speed Position Torque																													
	Setting range	Setting unit	Mfr's value	Effect																										
	50~30000	N/A	—	Effective Immediately																										
Please refer to 6.4.7 for details																														
Po018	Pluse output setting Speed Position Torque																													
	Setting range	Setting unit	Mfr's value	Effect																										
	Four-parameter	N/A	0001	Effective Immediately																										
<div style="display: flex; align-items: center; justify-content: center; gap: 20px;"> <div style="display: flex; gap: 10px;"> <div style="border: 1px solid black; padding: 2px 5px;">b</div> <div style="border: 1px solid black; width: 20px; height: 15px;"></div> <div style="border: 1px solid black; width: 20px; height: 15px;"></div> <div style="border: 1px solid black; width: 20px; height: 15px;"></div> <div style="border: 1px solid black; width: 20px; height: 15px;"></div> </div> <div style="margin-left: 20px;"> <table border="1" style="border-collapse: collapse; text-align: center;"> <tbody> <tr><td style="width: 20px;">A</td><td>Z pulse output polarity</td></tr> <tr><td>0</td><td>Negative</td></tr> <tr><td>1</td><td>Positive</td></tr> <tr><td>B</td><td>Z pulse command source</td></tr> <tr><td>0</td><td>Motor shaft</td></tr> <tr><td>1</td><td>Virtual shaft</td></tr> <tr><td>C</td><td>Command source of pulse frequency-division</td></tr> <tr><td>0</td><td>Motor shaft</td></tr> <tr><td>1</td><td>Internal position given</td></tr> <tr><td>2</td><td>Collector pulse input</td></tr> <tr><td>3</td><td>High-speed counter 1</td></tr> <tr><td>4</td><td>High-speed counter 2</td></tr> <tr><td>5</td><td>Position command</td></tr> </tbody> </table> </div> </div>					A	Z pulse output polarity	0	Negative	1	Positive	B	Z pulse command source	0	Motor shaft	1	Virtual shaft	C	Command source of pulse frequency-division	0	Motor shaft	1	Internal position given	2	Collector pulse input	3	High-speed counter 1	4	High-speed counter 2	5	Position command
A	Z pulse output polarity																													
0	Negative																													
1	Positive																													
B	Z pulse command source																													
0	Motor shaft																													
1	Virtual shaft																													
C	Command source of pulse frequency-division																													
0	Motor shaft																													
1	Internal position given																													
2	Collector pulse input																													
3	High-speed counter 1																													
4	High-speed counter 2																													
5	Position command																													

FL20-SA Series

Po019	Virtual Z output period Speed Position Torque			
	Setting range	Setting unit	Mfr's value	Effect
	1~2147483647	N/A	10000	Effective Immediately
One Z pulse is output per number of Po019 pulses, frequency-division source is determined by Po018.				
Po100	Internal enabled Speed Position Torque			
	Setting range	Setting unit	Mfr's value	Effect
	0~1	N/A	0	Effective Immediately
0: External terminal enabled. There must be terminal being set SON-I. 1: Internal enabled, which is determined by Internal Po100.				
Po101	First speed loop proportional gain Speed Position Torque			
	Setting range	Setting unit	Mfr's value	Effect
	0~30000	0.1Hz	600	Effective Immediately
Please refer to 7.3.3				
Po102	First speed loop integral gain Speed Position Torque			
	Setting range	Setting unit	Mfr's value	Effect
	0~10000	0.1ms	500	Effective Immediately
Please refer to 7.3.3				
Po103	Second speed loop proportional gain Speed Position Torque			
	Setting range	Setting unit	Mfr's value	Effect
	0~30000	0.1Hz	240	Effective Immediately
Please refer to 7.3.3				
Po104	Second speed loop integral gain Speed Position Torque			
	Setting range	Setting unit	Mfr's value	Effect
	0~30000	0.1ms	1250	Effective Immediately
Po105	First speed loop filter time constant Speed Position			
	Setting range	Setting unit	Mfr's value	Effect
	1~20000	0.01ms	—	Effective Immediately
Po106	Second speed loop filter time constant Speed Position			
	Setting range	Setting unit	Mfr's value	Effect
	1~20000	0.01ms	—	Effective Immediately

FL20-SA Series

Po107	Torque feedforward gain Speed Position			
	Setting range	Setting unit	Mfr's value	Effect
	0~1000	N/A	0	Effective Immediately
In speed and position mode, torque feedforward signal multiplied by Po107 equals torque feedback gain. Increasing Po107 can improve response of dynamic speed command and response of position command and reduce position error at constant speed.				
Po108	Torque feedforward gain filter Speed Position			
	Setting range	Setting unit	Mfr's value	Effect
	1~30000	0.01ms	100	Effective Immediately
Please refer to 7.3.3				
Po109	Acceleration time (only valid in speed mode) Speed			
	Setting range	Setting unit	Mfr's value	Effect
	1~30000	1ms	200	Effective Immediately
Po110	Deceleration time (only valid in speed mode) Speed			
	Setting range	Setting unit	Mfr's value	Effect
	1~30000	1ms	200	Effective Immediately
Po111	S curve accele/decel time Speed			
	Setting range	Setting unit	Mfr's value	Effect
	1~15000	1ms	100	Effective Immediately
Po112	S curve start Speed			
	Setting range	Setting unit	Mfr's value	Effect
	0~1	N/A	0	Effective Immediately
0: S curve is not valid 1: S curve is valid				
Po113	Internal speed given 1 Internal register speed			
	Setting range	Setting unit	Mfr's value	Effect
	0~±32000	0.1r/min	1000	Effective Immediately
Po114	Internal speed given 2 Internal register speed			
	Setting range	Setting unit	Mfr's value	Effect
	0~±32000	0.1r/min	2000	Effective Immediately

FL20-SA Series

Po115	Internal speed given 3			Internal register speed																																
	Setting range	Setting unit	Mfr's value	Effect																																
	0~±32000	0.1r/min	3000	Effective Immediately																																
Po117	Range of target speed			Speed																																
	Setting range	Setting unit	Mfr's value	Effect																																
	0~30000	0.1r/min	300	Effective Immediately																																
Po118	Rotation detection value			Speed																																
	Setting range	Setting unit	Mfr's value	Effect																																
	0~30000	0.1r/min	300	Effective Immediately																																
Po119	Home searching			Speed Position Torque																																
	Setting range	Setting unit	Mfr's value	Effect																																
	Four-parameter	N/A	0000	Effective Immediately																																
<table border="1" style="margin-left: 20px;"> <tbody> <tr> <td colspan="2">A Home searching mode</td> </tr> <tr> <td>0</td> <td>Reversal home searching</td> </tr> <tr> <td>1</td> <td>Forward home searching</td> </tr> <tr> <td colspan="2">B Home searching mode</td> </tr> <tr> <td>0</td> <td>Left-right position limitation as home reference</td> </tr> <tr> <td>1</td> <td>Input terminal ORGP as home reference</td> </tr> <tr> <td>2</td> <td>Nearest Z-phase pulse as home reference</td> </tr> <tr> <td>3</td> <td>Searching mechanical origin</td> </tr> <tr> <td colspan="2">C Home searching mode</td> </tr> <tr> <td>0</td> <td>Deceleration to stop after arriving at home reference</td> </tr> <tr> <td>1</td> <td>Searching Z signal at second speed with opposite direction after arriving at home reference</td> </tr> <tr> <td>2</td> <td>Searching Z signal at second speed with same direction after arriving at home reference</td> </tr> <tr> <td>3</td> <td>Searching the rising edge of input terminal ORGP as the Mechanical origin at the second speed with opposite direction after arriving at the input terminal ORGP.</td> </tr> <tr> <td colspan="2">D Home searching mode</td> </tr> <tr> <td>0</td> <td>Deceleration to stop after searching Z signal</td> </tr> <tr> <td>1</td> <td>Turn back to Z signal after searching Z signal</td> </tr> </tbody> </table>					A Home searching mode		0	Reversal home searching	1	Forward home searching	B Home searching mode		0	Left-right position limitation as home reference	1	Input terminal ORGP as home reference	2	Nearest Z-phase pulse as home reference	3	Searching mechanical origin	C Home searching mode		0	Deceleration to stop after arriving at home reference	1	Searching Z signal at second speed with opposite direction after arriving at home reference	2	Searching Z signal at second speed with same direction after arriving at home reference	3	Searching the rising edge of input terminal ORGP as the Mechanical origin at the second speed with opposite direction after arriving at the input terminal ORGP.	D Home searching mode		0	Deceleration to stop after searching Z signal	1	Turn back to Z signal after searching Z signal
A Home searching mode																																				
0	Reversal home searching																																			
1	Forward home searching																																			
B Home searching mode																																				
0	Left-right position limitation as home reference																																			
1	Input terminal ORGP as home reference																																			
2	Nearest Z-phase pulse as home reference																																			
3	Searching mechanical origin																																			
C Home searching mode																																				
0	Deceleration to stop after arriving at home reference																																			
1	Searching Z signal at second speed with opposite direction after arriving at home reference																																			
2	Searching Z signal at second speed with same direction after arriving at home reference																																			
3	Searching the rising edge of input terminal ORGP as the Mechanical origin at the second speed with opposite direction after arriving at the input terminal ORGP.																																			
D Home searching mode																																				
0	Deceleration to stop after searching Z signal																																			
1	Turn back to Z signal after searching Z signal																																			
Po120	Home/Mechanical origin searching at first speed			Speed Position Torque																																
	Setting range	Setting unit	Mfr's value	Effect																																
	0~20000	0.1r/min	500	Effective Immediately																																

FL20-SA Series

Po121	Home/Mechanical origin searching at second speed Speed Position Torque			
	Setting range	Setting unit	Mfr's value	Effect
	0~10000	0.1r/min	200	Effective Immediately
Po122	Home/Mechanical origin searching acceleration/deceleration time Speed Position Torque			
	Setting range	Setting unit	Mfr's value	Effect
	0~1000	ms	0	Effective Immediately
Po123	Home searching offset pulse Speed Position Torque			
	Setting range	Setting unit	Mfr's value	Effect
	-2147483647~+2147483647	N/A	0	Effective Immediately
Po125	Selection of home search function Speed Position Torque			
	Setting range	Setting unit	Mfr's value	Effect
	0~3	N/A	0	Effective Immediately
0: No home searching 1:Auto-searching when power-on 2:I/O port trigger 3:Start Immediate				
Po126	Speed value in the zero clamp Speed			
	Setting range	Setting unit	Mfr's value	Effect
	0 ~30000	0.1r/min	50	Effective Immediately
Po127	Zero clamp enabled Speed			
	Setting range	Setting unit	Mfr's value	Effect
	0 ~1	N/A	0	Effective Immediately
0: Zero clamp function OFF 1: Zero clamp function ON				
Po128	Home searching signal duration time Speed Position Torque			
	Setting range	Setting unit	Mfr's value	Effect
	1 ~30000	10ms	100	Effective Immediately
Po129	Home searching timeout Speed Position Torque			
	Setting range	Setting unit	Mfr's value	Effect
	10~65535	ms	10000	Effective Immediately
Po130	Gain switching setting Speed Position			
	Setting range	Setting unit	Mfr's value	Effect
	0~6	N/A	0	Effective Immediately

FL20-SA Series

Parameter	Content			
Po130=0	No switch, default to use gain 1			
Po130=1	No switch, default to use gain 2			
Po130=2	Switch to gain 2 Immediate when speed is higher than the setting value of Po131, if speed is lower than Po131, after delay the setting time of Po135(0.1ms), switch to gain 1.			
Po130=3	Switch terminal control, use gain 1 if the switching terminal defined in CN3 is invalid; use gain 2 if valid.			
Po130=4	Switch to gain 2 Immediate when position error is higher than the setting value of Po132; If lower than Po131, delay the setting time of Po135 (0.1ms), switch to gain 1.			
Po130=5	Switch to gain 2 Immediate if there is pulse input; if there is no pulse input, delay the setting time of Po135(0.1ms), then switch to gain 1.			
Po130=6	Switch to gain 2 Immediate if there is pulse input; If there is no pulse input and the speed is lower than Po131, delay the setting time of Po135(0.1ms), then switch to gain 1.			
Po131	Gain switching speed			Speed Position
	Setting range	Setting unit	Mfr's value	Effect
	1~32000	0.1r/min	100	Effective Immediately
Po132	Gain switching pulse			Speed Position
	Setting range	Setting unit	Mfr's value	Effect
	1~32000	N/A	100	Effective Immediately
Po133	Position loop gain switching time			Speed Position
	Setting range	Setting unit	Mfr's value	Effect
	1~32000	0.1ms	20	Effective Immediately
Po134	Speed loop gain switching time			Speed Position
	Setting range	Setting unit	Mfr's value	Effect
	0~20000	0.1ms	100	Effective Immediately
Po135	Gain 2 switch to gain 1 delay time			Speed Position
	Setting range	Setting unit	Mfr's value	Effect
	0~32000	0.1ms	1000	Effective Immediately
When gain 2 switches to gain 1, delay the time set by Po135, then switch the time according to the setting of Po133.				

FL20-SA Series

Po136	Mechanical origin single-turn value			Speed	Position	Torque
	Setting range	Setting unit	Mfr's value	Effect		
	0~2147483647	N/A	0	Effective Immediately		
Po138	Mechanical origin multi-turn value			Speed	Position	Torque
	Setting range	Setting unit	Mfr's value	Effect		
	0~2147483647	N/A	0	Effective Immediately		
Po140	Forward running range pulse when overtravel protection			Speed	Position	Torque
	Setting range	Setting unit	Mfr's value	Effect		
	0~2147483647	N/A	0	Effective Immediately		
Po142	Forward running range multi-loop numbers when overtravel protection			Speed	Position	Torque
	Setting range	Setting unit	Mfr's value	Effect		
	0~32000	N/A	1000	Effective Immediately		
Po143	Reverse running range pulse when overtravel protection			Speed	Position	Torque
	Setting range	Setting unit	Mfr's value	Effect		
	0~2147483647	N/A	0	Effective Immediately		
Po145	Reverse running range pulse when overtravel protection			Speed	Position	Torque
	Setting range	Setting unit	Mfr's value	Effect		
	0~32000	N/A	1000	Effective Immediately		
Po200	1 st current loop bandwidth			Speed	Position	Torque
	Setting range	Setting unit	Mfr's value	Effect		
	10~3000	HZ	—	Effective Immediately		
Please refer to 7.3.3						
Po201	2 nd current loop bandwidth			Speed	Position	Torque
	Setting range	Setting unit	Mfr's value	Effect		
	10~3000	HZ	—	Effective Immediately		
Please refer to 7.3.3						
Po202	Internal max torque limit value			Speed	Position	Torque
	Setting range	Setting unit	Mfr's value	Effect		
	0~800	1% of rated torque	200	Effective Immediately		

FL20-SA Series

Note:

1. When Po202 is larger than servo Max torque, torque limit value is Max servo motor torque.
2. Too small a torque limit setting will result in insufficient torque.

Po203	Torque limiting by analog Speed Position Torque			
	Setting range	Setting unit	Mfr's value	Effect
	0~1	N/A	0	Effective Immediately

When Po203=0, torque limiting by analog is invalid, when Po203=1, torque limiting by analog is valid. Torque limiting by analog takes input voltage of analog torque as control signal to limit torque. The relation between analog voltage and torque limiting value conforms to Po401.

Po204	Internal given torque Speed Position Torque			
	Setting range	Setting unit	Mfr's value	Effect
	-800~800	1% of rated torque	10	Effective Immediately

Po207	Forward/reverse run prohibited and emergency stop torque Speed Position Torque			
	Setting range	Setting unit	Mfr's value	Effect
	1~300	1% of rated torque	100	Effective Immediately

When forward/reverse run prohibited signal or emergency stop signal is valid, the max value of instantaneous reverse stop torque of servo motor is limited within the range of this value, and this value is an absolute value, it works on both forward run and reverse run.

Po208	Forward max torque limit Speed Position Torque			
	Setting range	Setting unit	Mfr's value	Effect
	0~800	1% of rated torque	100	Effective Immediately

Po209	Reverse max torque limit Speed Position Torque			
	Setting range	Setting unit	Mfr's value	Effect
	0~800	1% of rated torque	100	Effective Immediately

Po210	Speed Limit During Torque Control Torque			
	Setting range	Setting unit	Mfr's value	Effect
	N/A	0~2	2	Effective Immediately

Po210=0, Use the value set in Po211 as the speed limit..

Po210=1, Inputs an analog voltage command as the servo motor speed limit value, this is valid for forward/reverse rotation.

FL20-SA Series

Po210=2, Use the lower value between max rotation speed Po002 and actual motor max rotation speed as the speed limit.

Po211	Internal speed limit Torque			
	Setting range	Setting unit	Mfr's value	Effect
	0~32000	0.1r/min	20000	Effective Immediately
Po212	Torque increasing time Torque			
	Setting range	Setting unit	Mfr's value	Effect
	0~30000	0.1ms	0	Effective Immediately
Po213	Torque decreasing time Torque			
	Setting range	Setting unit	Mfr's value	Effect
	0~30000	0.1ms	0	Effective Immediately
Po214	1 st torque filter time constant Speed Position Torque			
	Setting range	Setting unit	Mfr's value	Effect
	0~30000	0.01ms	—	Effective Immediately
Po215	2 nd torque filter time constant Speed Position Torque			
	Setting range	Setting unit	Mfr's value	Effect
	0~30000	0.01ms	—	Effective Immediately
Please refer to 7.3.3				
Po216	Forward/reverse run prohibited torque setting Torque			
	Setting range	Setting unit	Mfr's value	Effect
	0~1	N/A	1	Effective Immediately

FL20-SA Series

0: Actual limit torque is Po207 1: Torque limit is 0				
Po217	1 st Notch filter center frequency Speed Position Torque			
	Setting range	Setting unit	Mfr's value	Effect
	50~30000	Hz	2000	Effective Immediately
Po218	1 st Notch filter width Speed Position Torque			
	Setting range	Setting unit	Mfr's value	Effect
	0~30000	Hz	5	Effective Immediately
Po219	1 st Notch filter depth Speed Position Torque			
	Setting range	Setting unit	Mfr's value	Effect
	0~100	N/A	0	Effective Immediately
Please refer to 7.4.				
Po220	2 nd Notch filter center frequency Speed Position Torque			
	Setting range	Setting unit	Mfr's value	Effect
	50~30000	Hz	2000	Effective Immediately
Please refer to 7.4.				
Po221	2 nd Notch filter width Speed Position Torque			
	Setting range	Setting unit	Mfr's value	Effect
	0~30000	Hz	5	Effective Immediately
Po222	2 nd Notch filter depth Speed Position Torque			
	Setting range	Setting unit	Mfr's value	Effect
	0~100	N/A	0	Effective Immediately
Po223	3 rd Notch filter center frequency Speed Position Torque			
	Setting range	Setting unit	Mfr's value	Effect
	50~30000	Hz	2000	Effective Immediately
Po224	3 rd Notch filter width Speed Position Torque			
	Setting range	Setting unit	Mfr's value	Effect
	0~30000	Hz	5	Effective Immediately
Po225	3 rd Notch filter depth Speed Position Torque			
	Setting range	Setting unit	Mfr's value	Effect

FL20-SA Series

	0~100	N/A	0	Effective Immediately
Po226	4 th Notch filter center frequency			<input type="checkbox"/> Speed <input type="checkbox"/> Position <input type="checkbox"/> Torque
	Setting range	Setting unit	Mfr's value	Effect
	50~30000	Hz	2000	Effective Immediately
Po227	4 th Notch filter width			<input type="checkbox"/> Speed <input type="checkbox"/> Position <input type="checkbox"/> Torque
	Setting range	Setting unit	Mfr's value	Effect
	0~30000	Hz	5	Effective Immediately
Po228	4 th Notch filter depth			<input type="checkbox"/> Speed <input type="checkbox"/> Position <input type="checkbox"/> Torque
	Setting range	Setting unit	Mfr's value	Effect
	0~100	N/A	0	Effective Immediately
Po229	Notch filter start			<input type="checkbox"/> Speed <input type="checkbox"/> Position <input type="checkbox"/> Torque
	Setting range	Setting unit	Mfr's value	Effect
	0~3	N/A	0	Effective Immediately
0: Off 1: On 2: Notch filter is auto-setting. 3: Clear filter data				
Po230	Notch filter number			<input type="checkbox"/> Speed <input type="checkbox"/> Position <input type="checkbox"/> Torque
	Setting range	Setting unit	Mfr's value	Effect
	1~4	N/A	2	Effective Immediately
Po231	Resonance threshold			<input type="checkbox"/> Speed <input type="checkbox"/> Position <input type="checkbox"/> Torque
	Setting range	Setting unit	Mfr's value	Effect
	1~30000	N/A	20	Effective Immediately
When resonance amplitude is higher than Po231, the point is detected as resonance point.				
Po234	Gain of load observer			<input type="checkbox"/> Speed <input type="checkbox"/> Position <input type="checkbox"/> Torque
	Setting range	Setting unit	Mfr's value	Effect
	0~1000	N/A	0	Effective Immediately
Load torque compensation may raise rigidity to some degree. But if it is set too large, there will be noise.				
Po235	Filter time of load observer			<input type="checkbox"/> Speed <input type="checkbox"/> Position <input type="checkbox"/> Torque
	Setting range	Setting unit	Mfr's value	Effect
	0~30000	0.01ms	1000	Effective Immediately
Setting Po235 may compensate load torque and enhance system rigidity to some extent. If filter time is set to low, noise will increase.				
Po236	Back EMF compensation coefficient			<input type="checkbox"/> Speed <input type="checkbox"/> Position <input type="checkbox"/> Torque

FL20-SA Series

	Setting range	Setting unit	Mfr's value	Effect
	0~1000	0.1%	500	Effective Immediately
Po237	Target torque range Torque			
	Setting range	Setting unit	Mfr's value	Effect
	1 ~ 50	1%	2	Effective Immediately
Po238	Torque filter frequency Torque			
	Setting range	Setting unit	Mfr's value	Effect
	1 ~ 1000	0.1Hz	10	Effective Immediately
Po240	Vibration suppression central frequency Position			
	Setting range	Setting unit	Mfr's value	Effect
	50~2000	0.1Hz	2000	Effective Immediately
Po242	Vibration suppression intensity Position			
	Setting range	Setting unit	Mfr's value	Effect
	0~100	N/A	0	Effective Immediately
Po289	Enable cogging torque compensation speed position torque			
	Setting Range	Setting Unit	Mfr's Value	Effect
	0~1	N/A	0	Re-power on
Po290	Friction compensation speed 1 speed position torque			
	Setting range	Setting unit	Mfr's value	Effect
	0~100	0.1%	10	Effective Immediately
Po291	Friction compensation coefficient 1 speed position torque			
	Setting Range	Setting Unit	Mfr's Value	Effect
	0~100	0.1%	0	Effective Immediately
Po292	Friction compensation speed 2 speed position torque			
	Setting Range	Setting Unit	Mfr's Value	Effect
	100~300	0.1%	100	Effective Immediately
Po293	Friction compensation coefficient 2 speed position torque			
	Setting Range	Setting Unit	Mfr's Value	Effect
	0~100	0.1%	0	Effective Immediately
Po294	Friction compensation speed 3 speed position torque			
	Setting Range	Setting Unit	Mfr's Value	Effect
	300~1000	0.1%	300	Effective Immediately
Po295	Friction compensation coefficient 3 speed position torque			

FL20-SA Series

	Setting Range	Setting Unit	Mfr's Value	Effect																																								
	0~100	0.1%	0	Effective Immediately																																								
Po300	Command pulse form Speed <input type="checkbox"/> Position <input type="checkbox"/> Torque <input type="checkbox"/>																																											
	Setting range	Setting unit	Mfr's value	Effect																																								
	Four-parameter	N/A	1000	Effective Immediately																																								
<div style="display: flex; align-items: center;"> <div style="margin-right: 20px;"> <p><input type="checkbox"/> <input type="checkbox"/> <input type="checkbox"/> <input type="checkbox"/></p> </div> <table border="1" style="border-collapse: collapse;"> <tr><td>A</td><td>Pulse mode</td></tr> <tr><td>0</td><td>Direction+pulse</td></tr> <tr><td>1</td><td>Pulse+pulse</td></tr> <tr><td>2</td><td>Orthogonal pulse (quadruplicated frequency)</td></tr> <tr><td>B</td><td>Pulse input filter frequency</td></tr> <tr><td>0</td><td>4MHz</td></tr> <tr><td>1</td><td>2MHz</td></tr> <tr><td>2</td><td>1MHz</td></tr> <tr><td>3</td><td>500KHz</td></tr> <tr><td>4</td><td>200KHz</td></tr> <tr><td>5</td><td>150KHz</td></tr> <tr><td>6</td><td>80KHz</td></tr> <tr><td>C</td><td>Pulse logic</td></tr> <tr><td>0</td><td>PULS negative logic SIGN negative logic</td></tr> <tr><td>1</td><td>PULS positive logic SIGN positive logic</td></tr> <tr><td>2</td><td>PULS negative logic SIGN positive logic</td></tr> <tr><td>3</td><td>PULS positive logic SIGN negative logic</td></tr> <tr><td>D</td><td>Frequency-division output</td></tr> <tr><td>0</td><td>CCW phase output</td></tr> <tr><td>1</td><td>CW phase output</td></tr> </table> </div>					A	Pulse mode	0	Direction+pulse	1	Pulse+pulse	2	Orthogonal pulse (quadruplicated frequency)	B	Pulse input filter frequency	0	4MHz	1	2MHz	2	1MHz	3	500KHz	4	200KHz	5	150KHz	6	80KHz	C	Pulse logic	0	PULS negative logic SIGN negative logic	1	PULS positive logic SIGN positive logic	2	PULS negative logic SIGN positive logic	3	PULS positive logic SIGN negative logic	D	Frequency-division output	0	CCW phase output	1	CW phase output
A	Pulse mode																																											
0	Direction+pulse																																											
1	Pulse+pulse																																											
2	Orthogonal pulse (quadruplicated frequency)																																											
B	Pulse input filter frequency																																											
0	4MHz																																											
1	2MHz																																											
2	1MHz																																											
3	500KHz																																											
4	200KHz																																											
5	150KHz																																											
6	80KHz																																											
C	Pulse logic																																											
0	PULS negative logic SIGN negative logic																																											
1	PULS positive logic SIGN positive logic																																											
2	PULS negative logic SIGN positive logic																																											
3	PULS positive logic SIGN negative logic																																											
D	Frequency-division output																																											
0	CCW phase output																																											
1	CW phase output																																											
Po301	1 st position loop gain Position <input type="checkbox"/>																																											
	Setting range	Setting unit	Mfr's value	Effect																																								
	1~30000	N/A	—	Effective Immediately																																								
Po302	2 nd position loop gain Position <input type="checkbox"/>																																											
	Setting range	Setting unit	Mfr's value	Effect																																								
	1~30000	N/A	—	Effective Immediately																																								
Po303	Position loop feedforward gain Position <input type="checkbox"/>																																											
	Setting range	Setting unit	Mfr's value	Effect																																								
	0~1000	N/A	0	Effective Immediately																																								
Po304	1 st group electronic gear numerator Position <input type="checkbox"/>																																											
	Setting range	Setting unit	Mfr's value	Effect																																								

FL20-SA Series

	0~65535	N/A	0	Effective Immediately																								
Po305	1 st electronic gear denominator			<u>Position</u>																								
	Setting range	Setting unit	Mfr's value	Effect																								
	0~65535	N/A	10000	Effective Immediately																								
Po306	Position loop filter time constant			<u>Position</u>																								
	Setting range	Setting unit	Mfr's value	Effect																								
	1~10000	ms	1	Effective Immediately																								
Po307	Position reach pulses range			<u>Position</u>																								
	Setting range	Setting unit	Mfr's value	Effect																								
	1~32000	N/A	—	Effective Immediately																								
Po308	Position pulse clear			<u>Position</u>																								
	Setting range	Setting unit	Mfr's value	Effect																								
	Four-parameter	N/A	—	Effective Immediately																								
<div style="display: flex; align-items: center;"> <div style="margin-right: 10px;">b</div> <div style="display: flex; gap: 10px;"> <div style="border: 1px solid black; width: 20px; height: 20px; display: flex; align-items: center; justify-content: center;">□</div> <div style="border: 1px solid black; width: 20px; height: 20px; display: flex; align-items: center; justify-content: center;">□</div> <div style="border: 1px solid black; width: 20px; height: 20px; display: flex; align-items: center; justify-content: center;">□</div> <div style="border: 1px solid black; width: 20px; height: 20px; display: flex; align-items: center; justify-content: center;">□</div> </div> </div> <table border="1" style="margin-left: 20px; margin-top: 10px;"> <tbody> <tr> <td>A</td> <td>Terminal of inhibiting command pulse</td> </tr> <tr> <td>0</td> <td>Invalid</td> </tr> <tr> <td>1</td> <td>Valid (INH-P must be allocated)</td> </tr> <tr> <td>B</td> <td>Command pulse clear</td> </tr> <tr> <td>0</td> <td>Invalid</td> </tr> <tr> <td>1</td> <td>Valid (CLR must be Allocated)</td> </tr> <tr> <td>C</td> <td>Position loop tracking error rate unit</td> </tr> <tr> <td>0</td> <td>1 pulse</td> </tr> <tr> <td>1</td> <td>100 pulses</td> </tr> <tr> <td>D</td> <td>Position loop tracking alarm rate unit</td> </tr> <tr> <td>0</td> <td>1 pulse</td> </tr> <tr> <td>1</td> <td>100 pulses</td> </tr> </tbody> </table>					A	Terminal of inhibiting command pulse	0	Invalid	1	Valid (INH-P must be allocated)	B	Command pulse clear	0	Invalid	1	Valid (CLR must be Allocated)	C	Position loop tracking error rate unit	0	1 pulse	1	100 pulses	D	Position loop tracking alarm rate unit	0	1 pulse	1	100 pulses
A	Terminal of inhibiting command pulse																											
0	Invalid																											
1	Valid (INH-P must be allocated)																											
B	Command pulse clear																											
0	Invalid																											
1	Valid (CLR must be Allocated)																											
C	Position loop tracking error rate unit																											
0	1 pulse																											
1	100 pulses																											
D	Position loop tracking alarm rate unit																											
0	1 pulse																											
1	100 pulses																											
Po309	Position error alarm pulses			<u>Position</u>																								
	Setting range	Setting unit	Mfr's value	Effect																								
	1~32000	N/A	—	Effective Immediately																								
Po310	Acceleration time of internal position 1			<u>Internal register position</u>																								
	Setting range	Setting unit	Mfr's value	Effect																								
	0~32000	ms	100	Effective Immediately																								

FL20-SA Series

Po311	Deceleration time of internal position 1			<u>Internal register position</u>
	Setting range	Setting unit	Mfr's value	Effect
	0~32000	ms	100	Effective Immediately
Po312	Acceleration time of internal position 2			<u>Internal register position</u>
	Setting range	Setting unit	Mfr's value	Effect
	0~32000	ms	100	Effective Immediately
Po313	Deceleration time of internal position 2			<u>Internal register position</u>
	Setting range	Setting unit	Mfr's value	Effect
	0~32000	ms	100	Effective Immediately
Po314	Acceleration time of internal position 3			<u>Internal register position</u>
	Setting range	Setting unit	Mfr's value	Effect
	0~32000	ms	100	Effective Immediately
Po315	Deceleration time of internal position 3			<u>Internal register position</u>
	Setting range	Setting unit	Mfr's value	Effect
	0~32000	ms	100	Effective Immediately
Po316	Acceleration time of internal position 4			<u>Internal register position</u>
	Setting range	Setting unit	Mfr's value	Effect
	0~32000	ms	100	Effective Immediately
Po317	Deceleration time of internal position 4			<u>Internal register position</u>
	Setting range	Setting unit	Mfr's value	Effect
	0~32000	ms	100	Effective Immediately
Po318	Acceleration time of internal position 5			<u>Internal register position</u>
	Setting range	Setting unit	Mfr's value	Effect
	0~32000	ms	100	Effective Immediately
Po319	Deceleration time of internal position 5			<u>Internal register position</u>
	Setting range	Setting unit	Mfr's value	Effect
	0~32000	ms	100	Effective Immediately
Po320	Acceleration time of internal position 6			<u>Internal register position</u>
	Setting range	Setting unit	Mfr's value	Effect

FL20-SA Series

	0~32000	ms	100	Effective Immediately
Po321	Deceleration time of internal position 6			<u>Internal register position</u>
	Setting range	Setting unit	Mfr's value	Effect
	0~32000	ms	100	Effective Immediately
Po322	Acceleration time of internal position 7			<u>Internal register position</u>
	Setting range	Setting unit	Mfr's value	Effect
	0~32000	ms	100	Effective Immediately
Po323	Deceleration time of internal position 7			<u>Internal register position</u>
	Setting range	Setting unit	Mfr's value	Effect
	0~32000	ms	100	Effective Immediately
Po324	Acceleration time of internal position 8			<u>Internal register position</u>
	Setting range	Setting unit	Mfr's value	Effect
	0~32000	ms	100	Effective Immediately
Po325	Deceleration time of internal position 8			<u>Internal register position</u>
	Setting range	Setting unit	Mfr's value	Effect
	0~32000	ms	100	Effective Immediately
Po326	Filter time constant of position feedforward			<u>Position</u>
	Setting range	Setting unit	Mfr's value	Effect
	1~32000	0.01ms	1000	Effective Immediately
Po327	No. of Position deviation alarm pulse			<u>Position</u>
	Setting range	Setting unit	Mfr's value	Effect
	1~30000	N/A	—	Effective Immediately
Po330	Given speed of postion 1			<u>Internal register position</u>
	Setting range	Setting unit	Mfr's value	Effect
	1~65535	0.1r/min	1000	Effective Immediately
Po331	Given speed of postion 2			<u>Internal register position</u>
	Setting range	Setting unit	Mfr's value	Effect
	1~65535	0.1r/min	1000	Effective Immediately

FL20-SA Series

Po332	Given speed of postion 3 Internal register position			
	Setting range	Setting unit	Mfr's value	Effect
	1~65535	0.1r/min	1000	Effective Immediately
Po333	Given speed of postion 4 Internal register position			
	Setting range	Setting unit	Mfr's value	Effect
	1~65535	0.1r/min	1000	Effective Immediately
Po334	Given speed of postion 5 Internal register position			
	Setting range	Setting unit	Mfr's value	Effect
	1~65535	0.1r/min	1000	Effective Immediately
Po335	Given speed of postion 6 Internal register position			
	Setting range	Setting unit	Mfr's value	Effect
	1~65535	0.1r/min	1000	Effective Immediately
Po336	Given speed of postion 7 Internal register position			
	Setting range	Setting unit	Mfr's value	Effect
	1~65535	0.1r/min	1000	Effective Immediately
Po337	Given speed of postion 8 Internal register position			
	Setting range	Setting unit	Mfr's value	Effect
	1~65535	0.1r/min	1000	Effective Immediately
Po338	Unit of position given speed Internal register position			
	Setting range	Setting unit	Mfr's value	Effect
	0~1	N/A	0	Effective Immediately
0: Motor actual speed, has no relation with electronic gear.Unit is 0.1r/min, 1: Treated by electronic gear, unit is 0.01Khz.				
Po339	Electronic gear ratio selection Position			
	Setting range	Setting unit	Mfr's value	Effect
	0~2	N/A	0	Effective Immediately
0: First electronic gear ratio 1: Second electronic gear ratio 2: Two groups of electronic gear ratio swithcover				

FL20-SA Series

Po340	FIR filter Position			
	Setting range	Setting unit	Mfr's value	Effect
	0~10000	0.1ms	0	Effective Immediately
The large the value, the smoother servo drive running, however, response may become slow.				
Po341	Internal position mode selection Internal register position			
	Setting range	Setting unit	Mfr's value	Effect
	0~1	N/A	0	Effective Immediately
0: Incremental mode 1: Absolute mode				
Po342	Internal position trigger Internal register position			
	Setting range	Setting unit	Mfr's value	Effect
	0~1	N/A	0	Effective Immediately
0: no trigger 1: trigger				
Po343	Acceleration/deceleration time in position mode Position			
	Setting range	Setting unit	Mfr's value	Effect
	0~10000	ms	0	Effective Immediately
Po344	2 ^{ed} group electronic gear numerator Position			
	Setting range	Setting unit	Mfr's value	Effect
	0~2147483647	N/A	0	Effective Immediately
Please refer to 6.4.2.				
Po346	2 ^{ed} electronic gear denominator Position			
	Setting range	Setting unit	Mfr's value	Effect
	1~2147483647	N/A	10000	Effective Immediately
Please refer to 6.4.2.				
Po348	Setting of multistage internal position Position			
	Setting range	Setting unit	Mfr's value	Effect
	Two-parameter	N/A	2 0	Effective Immediately

FL20-SA Series

<table border="1" style="display: inline-table; border-collapse: collapse;"> <tr> <td>X</td> <td>Multistage position function setting</td> </tr> <tr> <td>0</td> <td>Invalid</td> </tr> <tr> <td>1</td> <td>Valid</td> </tr> </table>					X	Multistage position function setting	0	Invalid	1	Valid		
X	Multistage position function setting											
0	Invalid											
1	Valid											
<table border="1" style="display: inline-table; border-collapse: collapse;"> <tr> <td>Y</td> <td>Stage numbers setting</td> </tr> <tr> <td>2</td> <td>Second position</td> </tr> <tr> <td>3</td> <td>Third position</td> </tr> <tr> <td>...</td> <td>...</td> </tr> </table>					Y	Stage numbers setting	2	Second position	3	Third position
Y	Stage numbers setting											
2	Second position											
3	Third position											
...	...											
Po349	Circulation times of multistage internal position <u>Position</u>											
	Setting range	Setting unit	Mfr's value	Effect								
	0~30000	N/A	0	Effective Immediately								
Please refer to 6.4.												
Po350	Given position of postion 1 <u>Internal register position</u>											
	Setting range	Setting unit	Mfr's value	Effect								
	-2147483647~+2147483647	N/A	0	Effective Immediately								
Po352	Given position of postion 2 <u>Internal register position</u>											
	Setting range	Setting unit	Mfr's value	Effect								
	-2147483647~+2147483647	N/A	0	Effective Immediately								
Po354	Given position of postion 3 <u>Internal register position</u>											
	Setting range	Setting unit	Mfr's value	Effect								
	-2147483647~+2147483647	N/A	0	Effective Immediately								
Po356	Given position of postion 4 <u>Internal register position</u>											
	Setting range	Setting unit	Mfr's value	Effect								
	-2147483647~+2147483647	N/A	0	Effective Immediately								
Po358	Given position of postion 5 <u>Internal register position</u>											
	Setting range	Setting unit	Mfr's value	Effect								
	-2147483647~+2147483647	N/A	0	Effective Immediately								
Po360	Given position of postion 6 <u>Internal register position</u>											
	Setting range	Setting unit	Mfr's value	Effect								
	-2147483647~+2147483647	N/A	0	Effective Immediately								

FL20-SA Series

Po362	Given position of position 7 <u>Internal register position</u>			
	Setting range	Setting unit	Mfr's value	Effect
	-2147483647~+2147483647	N/A	0	Effective Immediately
Po364	Given position of position 8 <u>Internal register position</u>			
	Setting range	Setting unit	Mfr's value	Effect
	-2147483647~+2147483647	N/A	0	Effective Immediately
Please refer to 6.4				
Po366	Interval time 1 <u>Internal register position</u>			
	Setting range	Setting unit	Mfr's value	Effect
	0~32000	ms	0	Effective Immediately
Po367	Interval time 2 <u>Internal register position</u>			
	Setting range	Setting unit	Mfr's value	Effect
	0~32000	ms	0	Effective Immediately
Po368	Interval time 3 <u>Internal register position</u>			
	Setting range	Setting unit	Mfr's value	Effect
	0~32000	ms	0	Effective Immediately
Po369	Interval time 4 <u>Internal register position</u>			
	Setting range	Setting unit	Mfr's value	Effect
	0~32000	ms	0	Effective Immediately
Po370	Interval time 5 <u>Internal register position</u>			
	Setting range	Setting unit	Mfr's value	Effect
	0~32000	ms	0	Effective Immediately
Po371	Interval time 6 <u>Internal register position</u>			
	Setting range	Setting unit	Mfr's value	Effect
	0~32000	ms	0	Effective Immediately
Po372	Interval time 7 <u>Internal register position</u>			
	Setting range	Setting unit	Mfr's value	Effect
	0~32000	ms	0	Effective Immediately
Po373	Interval time 8 <u>Internal register position</u>			

FL20-SA Series

	Setting range	Setting unit	Mfr's value	Effect																								
	0~32000	ms	0	Effective Immediately																								
Po374	Command source in position pulse mode			Position pulse																								
	Setting range	Setting unit	Mfr's value	Effect																								
	Four-parameter	N/A	0001	Effective Immediately																								
<div style="display: flex; align-items: center; justify-content: center;"> <div style="margin-right: 10px;">(b) <input type="checkbox"/> <input type="checkbox"/> <input type="checkbox"/> <input type="checkbox"/></div> <table border="1" style="margin-left: 20px; border-collapse: collapse;"> <tr><td style="text-align: center;">A</td><td>Pulse from Low-speed pulse</td></tr> <tr><td style="text-align: center;">0</td><td>Off</td></tr> <tr><td style="text-align: center;">1</td><td>On</td></tr> <tr><td style="text-align: center;">B</td><td>Pulse from high-speed counter 1</td></tr> <tr><td style="text-align: center;">0</td><td>Off</td></tr> <tr><td style="text-align: center;">1</td><td>On</td></tr> <tr><td style="text-align: center;">C</td><td>Pulse from internal position</td></tr> <tr><td style="text-align: center;">0</td><td>Off</td></tr> <tr><td style="text-align: center;">1</td><td>On</td></tr> <tr><td style="text-align: center;">D</td><td>Pulse from electronic cam</td></tr> <tr><td style="text-align: center;">0</td><td>Off</td></tr> <tr><td style="text-align: center;">1</td><td>On</td></tr> </table> </div>					A	Pulse from Low-speed pulse	0	Off	1	On	B	Pulse from high-speed counter 1	0	Off	1	On	C	Pulse from internal position	0	Off	1	On	D	Pulse from electronic cam	0	Off	1	On
A	Pulse from Low-speed pulse																											
0	Off																											
1	On																											
B	Pulse from high-speed counter 1																											
0	Off																											
1	On																											
C	Pulse from internal position																											
0	Off																											
1	On																											
D	Pulse from electronic cam																											
0	Off																											
1	On																											
Po375	Command source in internal register position mode			Internal register position																								
	Setting range	Setting unit	Mfr's value	Effect																								
	Four-parameter	N/A	0100	Effective Immediately																								
<div style="display: flex; align-items: center; justify-content: center;"> <div style="margin-right: 10px;">(b) <input type="checkbox"/> <input type="checkbox"/> <input type="checkbox"/> <input type="checkbox"/></div> <table border="1" style="margin-left: 20px; border-collapse: collapse;"> <tr><td style="text-align: center;">A</td><td>Pulse from Low-speed pulse</td></tr> <tr><td style="text-align: center;">0</td><td>Off</td></tr> <tr><td style="text-align: center;">1</td><td>On</td></tr> <tr><td style="text-align: center;">B</td><td>Pulse from high-speed counter 1</td></tr> <tr><td style="text-align: center;">0</td><td>Off</td></tr> <tr><td style="text-align: center;">1</td><td>On</td></tr> <tr><td style="text-align: center;">C</td><td>Pulse from internal position</td></tr> <tr><td style="text-align: center;">0</td><td>Off</td></tr> <tr><td style="text-align: center;">1</td><td>On</td></tr> <tr><td style="text-align: center;">D</td><td>Pulse from electronic cam</td></tr> <tr><td style="text-align: center;">0</td><td>Off</td></tr> <tr><td style="text-align: center;">1</td><td>On</td></tr> </table> </div>					A	Pulse from Low-speed pulse	0	Off	1	On	B	Pulse from high-speed counter 1	0	Off	1	On	C	Pulse from internal position	0	Off	1	On	D	Pulse from electronic cam	0	Off	1	On
A	Pulse from Low-speed pulse																											
0	Off																											
1	On																											
B	Pulse from high-speed counter 1																											
0	Off																											
1	On																											
C	Pulse from internal position																											
0	Off																											
1	On																											
D	Pulse from electronic cam																											
0	Off																											
1	On																											
Po376	Position feedback source			Position																								
	Setting range	Setting unit	Mfr's value	Effect																								
	0~2	N/A	0	Effective Immediately																								
0: Position feedback root in motor motor shaft 1: Position feedback root in high-speed counter 1 2: Position feedback root in high-speed counter 2																												

FL20-SA Series

Po377	Position feedback pulse proportion numerator Position			
	Setting range	Setting unit	Mfr's value	Effect
	1~65535	N/A	1	Effective Immediately
Po378	Position feedback pulse proportion denominator Position			
	Setting range	Setting unit	Mfr's value	Effect
	1~65535	N/A	1	Effective Immediately
Please refer to 6.4.12				
Po379	Mixed error remove turns Position			
	Setting range	Setting unit	Mfr's value	Effect
	0~32000	N/A	0	Effective Immediately
Please refer to 6.4.12				
Po380	Mixed error alarm pulses Position			
	Setting range	Setting unit	Mfr's value	Effect
	1~65535	N/A	1000	Effective Immediately
Please refer to 6.4.12				
Po381	Gantry synchron gain Position			
	Setting range	Setting unit	Mfr's value	Effect
	1~30000	N/A	1000	Effective Immediately
Po382	Gantry position feedback source Position			
	Setting range	Setting unit	Mfr's value	Effect
	0~1	N/A	0	Effective Immediately
Po383	Gantry synchron alarm pulse Position			
	Setting range	Setting unit	Mfr's value	Effect
	10~65535	N/A	1000	Effective Immediately
Po384	Gantry synchron feedback proportion numerator Position			
	Setting range	Setting unit	Mfr's value	Effect
	1~2147483647	N/A	10	Effective Immediately
Po386	Gantry synchron feedback proportion denominator Position			
	Setting range	Setting unit	Mfr's value	Effect

FL20-SA Series

	1~2147483647	N/A	10	Effective Immediately												
Please refer to 6.4.13																
Po388	Fixed length interrupt			Position												
	Setting range	Setting unit	Mfr's value	Effect												
	Two-parameter	N/A	00	Effective Immediately												
<table border="1" style="display: inline-table; margin-right: 20px;"> <tr><td>A</td><td>Interrupt fixed length function</td></tr> <tr><td>0</td><td>Invalid</td></tr> <tr><td>1</td><td>Valid</td></tr> </table> <table border="1" style="display: inline-table;"> <tr><td>B</td><td>Interrupt fixed length release terminal</td></tr> <tr><td>0</td><td>Invalid</td></tr> <tr><td>1</td><td>Valid</td></tr> </table>					A	Interrupt fixed length function	0	Invalid	1	Valid	B	Interrupt fixed length release terminal	0	Invalid	1	Valid
A	Interrupt fixed length function															
0	Invalid															
1	Valid															
B	Interrupt fixed length release terminal															
0	Invalid															
1	Valid															
Po400	Max speed corresponding to analog voltage			Speed												
	Setting range	Setting unit	Mfr's value	Effect												
	1~10000	r/min	—	Effective Immediately												
Po401	Max torque corresponding to Analog torque			Torque												
	Setting range	Setting unit	Mfr's value	Effect												
	1~800	1% of rated torque	100	Effective Immediately												
Po402	AI1 command zero drift compensation			Speed Position Torque												
	Setting range	Setting unit	Mfr's value	Effect												
	0~±5000	mv	0	Effective Immediately												
Po403	AI2 torque command zero drift compensation			Speed Position Torque												
	Setting range	Setting unit	Mfr's value	Effect												
	0~±5000	mv	0	Effective Immediately												
Po404	Analog speed command filter time constant			Speed Position Torque												
	Setting range	Setting unit	Mfr's value	Effect												
	1~30000	0.01ms	200	Effective Immediately												
Po405	Analog torque command filter time constant			Torque												
	Setting range	Setting unit	Mfr's value	Effect												
	1~30000	0.01ms	200	Effective Immediately												
Po406	AI automatic zero set			Speed Torque												

FL20-SA Series

	Setting range	Setting unit	Mfr's value	Effect
	0~1	N/A	0	Effective Immediately
Po407	DI1 terminal function			<input type="checkbox"/> Speed <input type="checkbox"/> Position <input type="checkbox"/> Torque
	Setting range	Setting unit	Mfr's value	Effect
	Two-parameter	N/A	—	Repower on
Po408	DI2 terminal function			<input type="checkbox"/> Speed <input type="checkbox"/> Position <input type="checkbox"/> Torque
	Setting range	Setting unit	Mfr's value	Effect
	Two-parameter	N/A	—	Repower on
Po409	DI3 terminal function			<input type="checkbox"/> Speed <input type="checkbox"/> Position <input type="checkbox"/> Torque
	Setting range	Setting unit	Mfr's value	Effect
	Two-parameter	N/A	—	Repower on
Po410	DI4 terminal function			<input type="checkbox"/> Speed <input type="checkbox"/> Position <input type="checkbox"/> Torque
	Setting range	Setting unit	Mfr's value	Effect
	Two-parameter	N/A	—	Repower on
Po411	DI5 terminal function			<input type="checkbox"/> Speed <input type="checkbox"/> Position <input type="checkbox"/> Torque
	Setting range	Setting unit	Mfr's value	Effect
	Two-parameter	N/A	—	Repower on
Po412	DI6 terminal function			<input type="checkbox"/> Speed <input type="checkbox"/> Position <input type="checkbox"/> Torque
	Setting range	Setting unit	Mfr's value	Effect
	Two-parameter	N/A	—	Repower on
Po413	DI7 terminal function			<input type="checkbox"/> Speed <input type="checkbox"/> Position <input type="checkbox"/> Torque
	Setting range	Setting unit	Mfr's value	Effect
	Two-parameter	N/A	—	Repower on
Po414	DI8 terminal function			<input type="checkbox"/> Speed <input type="checkbox"/> Position <input type="checkbox"/> Torque
	Setting range	Setting unit	Mfr's value	Effect
	Two-parameter	N/A	—	Repower on
Po421	DO1 terminal function			<input type="checkbox"/> Speed <input type="checkbox"/> Position <input type="checkbox"/> Torque
	Setting range	Setting unit	Mfr's value	Effect
	Two-parameter	N/A	—	Repower on

FL20-SA Series

Po422	DO2 terminal function			Speed Position Torque
	Setting range	Setting unit	Mfr's value	Effect
	Two-parameter	N/A	—	Repower on
Po423	DO3 terminal function			Speed Position Torque
	Setting range	Setting unit	Mfr's value	Effect
	Two-parameter	N/A	—	Repower on
Po424	DO4 terminal function			Speed Position Torque
	Setting range	Setting unit	Mfr's value	Effect
	Two-parameter	N/A	—	Repower on
Po425	ALM terminal function			Speed Position Torque
	Setting range	Setting unit	Mfr's value	Effect
	Two-parameter	N/A	—	Repower on
Please refer to 8.1.7				
Po426	AI zero drift alarm			Speed Position Torque
	Setting range	Setting unit	Mfr's value	Effect
	100~5000	mv	2000	Effective Immediately
Po427	Analog terminal control			Speed
	Setting range	Setting unit	Mfr's value	Effect
	0~1	N/A	0	Effective Immediately
0: Off 1:On				
Po428	Analog speed mode setting			Speed Torque
	Setting range	Setting unit	Mfr's value	Effect
	0~1	N/A	0	Effective Immediately
0: Analog command is set by AI1. 1: Analog command is set by AI2.				
Po429	Analog torque command source			Speed Position Torque
	Setting range	Setting unit	Mfr's value	Effect
	0~1	N/A	1	Effective Immediately

FL20-SA Series

Po430	Corresponding speed of lower limit voltage			Speed	Position	Torque
	Setting range	Setting unit	Mfr's value	Effect		
	-1000~1000	0.1%	-1000	Effective Immediately		
Please refer to 6.2						
Po431	Corresponding speed of lower limit voltage			Speed	Position	Torque
	Setting range	Setting unit	Mfr's value	Effect		
	-1000~1000	0.01V	-1000	Effective Immediately		
Please refer to 6.2						
Po432	Corresponding speed of upper limit voltage			Speed	Position	Torque
	Setting range	Setting unit	Mfr's value	Effect		
	-1000~1000	0.1%	1000	Effective Immediately		
Please refer to 6.2						
Po433	Upper limit voltage in speed analog mode			Speed	Position	Torque
	Setting range	Setting unit	Mfr's value	Effect		
	-1000~1000	0.01V	1000	Effective Immediately		
Please refer to 6.2						
Po434	Torque corresponding to lower limit voltage in torque analog mode			Speed	Position	Torque
	Setting range	Setting unit	Mfr's value	Effect		
	-1000~1000	0.1%	-1000	Effective Immediately		
Please refer to 6.3						
Po435	Lower limit voltage in torque analog mode			Speed	Position	Torque
	Setting range	Setting unit	Mfr's value	Effect		
	-1000~1000	0.01V	-1000	Effective Immediately		
Please refer to 6.3						
Po436	Torque corresponding to upper limit voltage in torque analog mode			Speed	Position	Torque
	Setting range	Setting unit	Mfr's value	Effect		
	-1000~1000	0.1%	1000	Effective Immediately		
Please refer to 6.3						
Po437	Upper limit voltage in torque analog mode			Speed	Position	Torque
	Setting range	Setting unit	Mfr's value	Effect		

FL20-SA Series

	-1000~1000	0.01V	1000	Effective Immediately
Please refer to 6.3				
Po438	DI1 filter time			<input type="checkbox"/> Speed <input type="checkbox"/> Position <input type="checkbox"/> Torque
	Setting range	Setting unit	Mfr's value	Effect
	0~30000	N/A	2	Effective Immediately
Po439	DI2 filter time			<input type="checkbox"/> Speed <input type="checkbox"/> Position <input type="checkbox"/> Torque
	Setting range	Setting unit	Mfr's value	Effect
	0~30000	N/A	2	Effective Immediately
Po440	DI3 filter time			<input type="checkbox"/> Speed <input type="checkbox"/> Position <input type="checkbox"/> Torque
	Setting range	Setting unit	Mfr's value	Effect
	0~30000	N/A	2	Effective Immediately
Po441	DI4 filter time			<input type="checkbox"/> Speed <input type="checkbox"/> Position <input type="checkbox"/> Torque
	Setting range	Setting unit	Mfr's value	Effect
	0~30000	N/A	2	Effective Immediately
Po442	DI5 filter time			<input type="checkbox"/> Speed <input type="checkbox"/> Position <input type="checkbox"/> Torque
	Setting range	Setting unit	Mfr's value	Effect
	0~30000	N/A	2	Effective Immediately
Po443	DI6 filter time			<input type="checkbox"/> Speed <input type="checkbox"/> Position <input type="checkbox"/> Torque
	Setting range	Setting unit	Mfr's value	Effect
	0~30000	N/A	2	Effective Immediately
Po444	DI7 filter time			<input type="checkbox"/> Speed <input type="checkbox"/> Position <input type="checkbox"/> Torque
	Setting range	Setting unit	Mfr's value	Effect
	0~30000	N/A	2	Effective Immediately
Po445	DI8 filter time			<input type="checkbox"/> Speed <input type="checkbox"/> Position <input type="checkbox"/> Torque
	Setting range	Setting unit	Mfr's value	Effect
	0~30000	N/A	2	Effective Immediately
Po500	Communication address			<input type="checkbox"/> Speed <input type="checkbox"/> Position <input type="checkbox"/> Torque
	Setting range	Setting unit	Mfr's value	Effect
	1~254	N/A	1	Effective Immediately

Please refer to chapter 10						
Po501	Communication mode			Speed	Position	Torque
	Setting range	Setting unit	Mfr's value	Effect		
	0~1	N/A	1	Effective Immediately		
Please refer to chapter 10						
Po502	Stop bit			Speed	Position	Torque
	Setting range	Setting unit	Mfr's value	Effect		
	0~1	N/A	0	Effective Immediately		
0: 1bit 1: 2 bits						
Po503	Parity check selection			Speed	Position	Torque
	Setting range	Setting unit	Mfr's value	Effect		
	0~2	N/A	0	Effective Immediately		
0: No checkout 1: Odd 2: Even						
Po504	Baud rate			Speed	Position	Torque
	Setting range	Setting unit	Mfr's value	Effect		
	0~5	bit/s	3	Effective Immediately		
0: 2400 1: 4800 2: 9600 3: 19200 4: 38400 5: 57600						
Po505	Permission of Read&Write			Speed	Position	Torque
	Setting range	Setting unit	Mfr's value	Effect		
	0~1	N/A	1	Effective Immediately		
0: Permission of Read & Write, the communication data is allowed to be written into data register. 1: Prohibition of Read&Write, the communication commands are only executed, but they are not allowed to be written into data register. If the servodrive is power off, data will be lost and they need to be written again.						

8.1.4 Motor function group (Ho-□□□)

Ho000	Rated voltage of servo motor			Speed	Position	Torque
	Setting range	Setting unit	Mfr's value	Effect		
	1~30000	V	—	Effective Immediately		
Please set Ho000 according to servo motor nameplate.						
Ho001	Rated current of servo motor			Speed	Position	Torque

FL20-SA Series

	Setting range	Setting unit	Mfr's value	Effect
	1~30000	0.1A	—	Effective Immediately
Please set Ho001 according to servo motor nameplate.				
Ho002	Max speed of servo motor			<input type="checkbox"/> Speed <input type="checkbox"/> Position <input type="checkbox"/> Torque
	Setting range	Setting unit	Mfr's value	Effect
	0~32000	r/min	—	Effective Immediately
Please set Ho002 according to servo motor nameplate.				
Ho003	Rated speed of servo motor			<input type="checkbox"/> Speed <input type="checkbox"/> Position <input type="checkbox"/> Torque
	Setting range	Setting unit	Mfr's value	Effect
	1~32000	r/min	—	Effective Immediately
Please set Ho003 according to servo motor nameplate.				
Ho004	Pole-pairs			<input type="checkbox"/> Speed <input type="checkbox"/> Position <input type="checkbox"/> Torque
	Setting range	Setting unit	Mfr's value	Effect
	1~30	pair	—	Effective Immediately
If servo motor is 8 poles, Ho004 is 4.				
Ho005	Phase resistance			<input type="checkbox"/> Speed <input type="checkbox"/> Position <input type="checkbox"/> Torque
	Setting range	Setting unit	Mfr's value	Effect
	0~65535	$10^{-3}\Omega$	—	Effective Immediately
Ho006	D-axis inductance			<input type="checkbox"/> Speed <input type="checkbox"/> Position <input type="checkbox"/> Torque
	Setting range	Setting unit	Mfr's value	Effect
	0~65535	$10^{-6}H$	—	Effective Immediately
Ho007	Q-axis inductance			<input type="checkbox"/> Speed <input type="checkbox"/> Position <input type="checkbox"/> Torque
	Setting range	Setting unit	Mfr's value	Effect
	0~65535	$10^{-6}H$	—	Effective Immediately
Ho008	Back EMF line voltage effective value			<input type="checkbox"/> Speed <input type="checkbox"/> Position <input type="checkbox"/> Torque
	Setting range	Setting unit	Mfr's value	Effect
	0~30000	0.1V/1000 r/min	—	Effective Immediately
Ho011	Motor power			<input type="checkbox"/> Speed <input type="checkbox"/> Position <input type="checkbox"/> Torque
	Setting range	Setting unit	Mfr's value	Effect
	1~30000	0.01KW	—	Effective Immediately

FL20-SA Series

Ho012	Motor rotary inertia Speed Position Torque			
	Setting range	Setting unit	Mfr's value	Effect
	0~2147483647	10 ⁻⁶ Kg•m2	—	Effective Immediately
Ho016	Encoder resolution Speed Position Torque			
	Setting range	Setting unit	Mfr's value	Effect
	0~2147483647	PPR	—	Effective Immediately
Ho018	Encoder installation angle Speed Position Torque			
	Setting range	Setting unit	Mfr's value	Effect
	-2147483647~+2147483647 47	N/A	—	Effective Immediately
Ho121	Encoder installation angle Speed Position Torque			
	Setting range	Setting unit	Mfr's value	Effect
	1~30000	N/A	500	Effective Immediately

8.1.5 Alarm Record Parameters (Ho2□□~Ho3□□)

Ho200 ~ Ho235	AL01~AL32 alarming times Speed Position Torque			
	Setting range	Setting unit	Mfr's value	Effect
	—	—	—	—
Ho300	PN voltage at last time alarm Speed Position Torque			
	Setting range	Setting unit	Mfr's value	Effect
	—	—	—	—
Ho301	Current at last time alarm Speed Position Torque			
	Setting range	Setting unit	Mfr's value	Effect
	—	—	—	—
Ho302	Motor speed at last time alarm Speed Position Torque			
	Setting range	Setting unit	Mfr's value	Effect
	—	—	—	—
Ho303	PN voltage at second last time alarm Speed Position Torque			
	Setting range	Setting unit	Mfr's value	Effect
	—	—	—	—

FL20-SA Series

Ho304	Current at second last time alarm Speed Position Torque			
	Setting range	Setting unit	Mfr's value	Effect
	—	—	—	—
Ho305	Motor speed at second last time alarm Speed Position Torque			
	Setting range	Setting unit	Mfr's value	Effect
	—	—	—	—
Ho306	PN voltage at third last time alarm Speed Position Torque			
	Setting range	Setting unit	Mfr's value	Effect
	—	—	—	—
Ho307	Current at third last time alarm Speed Position Torque			
	Setting range	Setting unit	Mfr's value	Effect
	—	—	—	—
Ho308	Motor speed at third last time alarm Speed Position Torque			
	Setting range	Setting unit	Mfr's value	Effect
	—	—	—	—
Ho310	Alarm code at last time Speed Position Torque			
	Setting range	Setting unit	Mfr's value	Effect
	—	—	—	—
Ho311	Alarm code at second last time Speed Position Torque			
	Setting range	Setting unit	Mfr's value	Effect
	—	—	—	—
Ho312	Alarm code at third last time Speed Position Torque			
	Setting range	Setting unit	Mfr's value	Effect
	—	—	—	—
Ho313	Alarm code at fourth last time Speed Position Torque			
	Setting range	Setting unit	Mfr's value	Effect
	—	—	—	—
Ho314	Alarm code at fifth last time Speed Position Torque			
	Setting range	Setting unit	Mfr's value	Effect

FL20-SA Series

	—	—	—	—
Ho315	Alarm code at sixth last time			Speed Position Torque
	Setting range	Setting unit	Mfr's value	Effect
	—	—	—	—
Ho316	Alarm code at seventh last time			Speed Position Torque
	Setting range	Setting unit	Mfr's value	Effect
	—	—	—	—
Ho317	Alarm code at eighth last time			Speed Position Torque
	Setting range	Setting unit	Mfr's value	Effect
	—	—	—	—
Ho318	Alarm code at ninth last time			Speed Position Torque
	Setting range	Setting unit	Mfr's value	Effect
	—	—	—	—
Ho319	Alarm code at tenth last time			Speed Position Torque
	Setting range	Setting unit	Mfr's value	Effect
	—	—	—	—
Ho320	Alarm time at last time			Speed Position Torque
	Setting range	Setting unit	Mfr's value	Effect
	—	—	—	—
Ho321	Alarm time at second last time			Speed Position Torque
	Setting range	Setting unit	Mfr's value	Effect
	—	—	—	—
Ho322	Alarm time at third last time			Speed Position Torque
	Setting range	Setting unit	Mfr's value	Effect
	—	—	—	—
Ho323	Alarm time at fourth last time			Speed Position Torque
	Setting range	Setting unit	Mfr's value	Effect
	—	—	—	—
Ho324	Alarm time at fifth last time			Speed Position Torque

FL20-SA Series

	Setting range	Setting unit	Mfr's value	Effect
	—	—	—	—
Ho325	Alarm time at sixth last time			Speed Position Torque
	Setting range	Setting unit	Mfr's value	Effect
	—	—	—	—
Ho326	Alarm time at seventh last time			Speed Position Torque
	Setting range	Setting unit	Mfr's value	Effect
	—	—	—	—
Ho327	Alarm time at eighth last time			Speed Position Torque
	Setting range	Setting unit	Mfr's value	Effect
	—	—	—	—
Ho328	Alarm time at ninth last time			Speed Position Torque
	Setting range	Setting unit	Mfr's value	Effect
	—	—	—	—
Ho329	Alarm time at tenth last time			Speed Position Torque
	Setting range	Setting unit	Mfr's value	Effect
	—	—	—	—

8.1.6 High-speed counter parameters (PL□□□)

PL000	E-Cam Control			Speed Position Torque
	Setting Range	Setting Unit	Mfr's Value	Effect
	Four-parameter	N/A	0000	Effective Immediately

FL20-SA Series

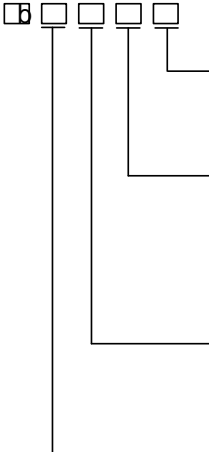
	 <table border="1" data-bbox="727 199 991 656"> <tr><td>A</td><td>Electronic cam</td></tr> <tr><td>0</td><td>Close electronic cam</td></tr> <tr><td>1</td><td>Open electronic cam</td></tr> <tr><td>B</td><td>Command resource</td></tr> <tr><td>0</td><td>High counter 1</td></tr> <tr><td>1</td><td>High counter 2</td></tr> <tr><td>2</td><td>Internal position</td></tr> <tr><td>3</td><td>Time</td></tr> <tr><td>C</td><td>Trigger resource</td></tr> <tr><td>0</td><td>Trigger immediately</td></tr> <tr><td>1</td><td>DI2 trigger</td></tr> <tr><td>2</td><td>CAP0 Trigger</td></tr> <tr><td>3</td><td>CAP1 Trigger</td></tr> <tr><td>D</td><td>Detachment condition</td></tr> <tr><td>0</td><td>No detachment</td></tr> <tr><td>1</td><td>DI control</td></tr> <tr><td>2</td><td>Out of range</td></tr> </table>				A	Electronic cam	0	Close electronic cam	1	Open electronic cam	B	Command resource	0	High counter 1	1	High counter 2	2	Internal position	3	Time	C	Trigger resource	0	Trigger immediately	1	DI2 trigger	2	CAP0 Trigger	3	CAP1 Trigger	D	Detachment condition	0	No detachment	1	DI control	2	Out of range
A	Electronic cam																																					
0	Close electronic cam																																					
1	Open electronic cam																																					
B	Command resource																																					
0	High counter 1																																					
1	High counter 2																																					
2	Internal position																																					
3	Time																																					
C	Trigger resource																																					
0	Trigger immediately																																					
1	DI2 trigger																																					
2	CAP0 Trigger																																					
3	CAP1 Trigger																																					
D	Detachment condition																																					
0	No detachment																																					
1	DI control																																					
2	Out of range																																					
PL001	E-cam Initial Position			Speed	Position	Torque																																
	Setting Range	Setting Unit	Mfr's Value	Effect																																		
	-2147483647~+2147483647	N/A	0	Effective Immediately																																		
PL003	E-cam Occlusion Contact			Speed	Position	Torque																																
	Setting Range	Setting Unit	Mfr's Value	Effect																																		
	-2147483647~+2147483647	N/A	0	Effective Immediately																																		
PL005	E-cam Occlusion Release Point			Speed	Position	Torque																																
	Setting Range	Setting Unit	Mfr's Value	Effect																																		
	-2147483647~+2147483647	N/A	0	Effective Immediately																																		
PL007	E-cam master axis numerator			Speed	Position	Torque																																
	Setting Range	Setting Unit	Mfr's Value	Effect																																		
	1~+2147483647	N/A	1	Effective Immediately																																		
PL009	E-cam master axis denominator			Speed	Position	Torque																																
	Setting Range	Setting Unit	Mfr's Value	Effect																																		
	1~+2147483647	N/A	1	Effective Immediately																																		
PL011	DO valid initial position			Speed	Position	Torque																																
	Setting Range	Setting Unit	Mfr's Value	Effect																																		
	0~2147483647	N/A	0	Effective Immediately																																		
PL013	DO valid ending position			Speed	Position	Torque																																
	Setting Range	Setting Unit	Mfr's Value	Effect																																		
	0~2147483647	N/A	0	Effective Immediately																																		

FL20-SA Series

PL015	E-cam Points			Speed	Position	Torque
	Setting Range	Setting Unit	Mfr's Value	Effect		
	5~720	N/A	5	Effective Immediately		
PL016	E-cam Pages			Speed	Position	Torque
	Setting Range	Setting Unit	Mfr's Value	Effect		
	0~14	N/A	0	Effective Immediately		
PL017	E-cam Table Refresh			Speed	Position	Torque
	Setting Range	Setting Unit	Mfr's Value	Effect		
	0~1	N/A	0	Effective Immediately		
	0: Cam Table no refresh; 1: Cam Table refresh;					
PL018	E-cam Table Status			Speed	Position	Torque
	Setting Range	Setting Unit	Mfr's Value	Effect		
	0~3	N/A	0	Effective Immediately		
	0: Ready to start; 1: Waiting for engaged trigger; 2: Pre-engaged Status; 3: Running Status;					
PL019	Master Axis Position			Speed	Position	Torque
	Setting Range	Setting Unit	Mfr's Value	Effect		
	0~2147483647	N/A	0	Check		
PL021	E-cam disengaged is captured again or not			Speed	Position	Torque
	Setting Range	Setting Unit	Mfr's Value	Effect		
	0~1	N/A	0	Effective Immediately		
PL021=1, capture again. When selecting CAP trigger, the CAP and reset of high-speed counter are need to set as same source.						
PL022	Initial address of E-cam adjustment			Speed	Position	Torque
	Setting Range	Setting Unit	Mfr's Value	Effect		
	0~300	N/A	0	Effective Immediately		
PL023	Master axis variation			Speed	Position	Torque
	Setting Range	Setting Unit	Mfr's Value	Effect		
	-2147483647~+2147483647	N/A	0	Effective Immediately		
PL025	Slave axis variation			Speed	Position	Torque

FL20-SA Series

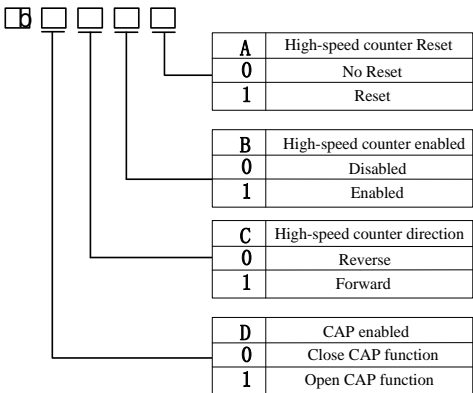
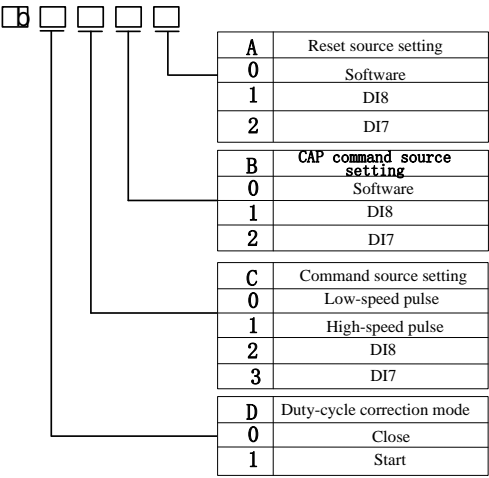
	Setting Range	Setting Unit	Mfr's Value	Effect
	-2147483647~+2147483647	N/A	0	Effective Immediately
PL100	High-speed counter 1 control command			<u>Speed</u> <u>Position</u> <u>Torque</u>
	Setting Range	Setting Unit	Mfr's Value	Effect
	Four-parameter	N/A	0010	Effective Immediately
				
PL101	High-speed counter 1 command source			<u>speed</u> <u>position</u> <u>torque</u>
	Setting Range	Setting Unit	Mfr's Value	Effect
	Four-parameter	N/A	0100	Effective Immediately
				
PL102	High-speed counter 1 compare register			<u>speed</u> <u>position</u> <u>torque</u>
	Setting Range	Setting Unit	Mfr's Value	Effect
	-2147483647~+2147483647	N/A	0	Effective Immediately
PL104	High-speed counter 1 periodic value			<u>speed</u> <u>position</u> <u>torque</u>

FL20-SA Series

	Setting Range	Setting Unit	Mfr's Value	Effect																								
	-2147483647~+2147483647	N/A	0	Effective Immediately																								
PL106	High-speed counter 1 count value			<u>speed</u> <u>position</u> <u>torque</u>																								
	Setting Range	Setting Unit	Mfr's Value	Effect																								
	-2147483647~+2147483647	N/A	0	Check																								
PL108	High-speed counter1 CAP value			<u>speed</u> <u>position</u> <u>torque</u>																								
	Setting Range	Setting Unit	Mfr's Value	Effect																								
	-2147483647~+2147483647	N/A	0	Check																								
PL110	High-speed counter 2 control command			<u>speed</u> <u>position</u> <u>torque</u>																								
	Setting Range	Setting Unit	Mfr's Value	Effect																								
	Four- parameter	N/A	0000	Effective Immediately																								
	<table border="1"> <tr> <td>A</td> <td>High-speed counter Reset</td> </tr> <tr> <td>0</td> <td>No Reset</td> </tr> <tr> <td>1</td> <td>Reset</td> </tr> <tr> <td>B</td> <td>High-speed counter enabled</td> </tr> <tr> <td>0</td> <td>Disabled</td> </tr> <tr> <td>1</td> <td>Enabled</td> </tr> <tr> <td>C</td> <td>High-speed counter direction</td> </tr> <tr> <td>0</td> <td>Reverse</td> </tr> <tr> <td>1</td> <td>Forward</td> </tr> <tr> <td>D</td> <td>CAP enabled</td> </tr> <tr> <td>0</td> <td>Close CAP function</td> </tr> <tr> <td>1</td> <td>Open CAP function</td> </tr> </table>				A	High-speed counter Reset	0	No Reset	1	Reset	B	High-speed counter enabled	0	Disabled	1	Enabled	C	High-speed counter direction	0	Reverse	1	Forward	D	CAP enabled	0	Close CAP function	1	Open CAP function
	A	High-speed counter Reset																										
0	No Reset																											
1	Reset																											
B	High-speed counter enabled																											
0	Disabled																											
1	Enabled																											
C	High-speed counter direction																											
0	Reverse																											
1	Forward																											
D	CAP enabled																											
0	Close CAP function																											
1	Open CAP function																											
PL111	High-speed counter 2 command source			<u>speed</u> <u>position</u> <u>torque</u>																								
	Setting Range	Setting Unit	Mfr's Value	Effect																								
	Four-parameter	N/A	0100	Effective Immediately																								

FL20-SA Series

				<table border="1" style="width: 100%; border-collapse: collapse;"> <tr> <td style="text-align: center;">A</td> <td>Reset source setting</td> </tr> <tr> <td style="text-align: center;">0</td> <td>Software</td> </tr> <tr> <td style="text-align: center;">1</td> <td>DI8</td> </tr> <tr> <td style="text-align: center;">2</td> <td>DI7</td> </tr> <tr> <td style="text-align: center;">B</td> <td>CAP command source setting</td> </tr> <tr> <td style="text-align: center;">0</td> <td>Software</td> </tr> <tr> <td style="text-align: center;">1</td> <td>DI8</td> </tr> <tr> <td style="text-align: center;">2</td> <td>DI7</td> </tr> <tr> <td style="text-align: center;">C</td> <td>Command source setting</td> </tr> <tr> <td style="text-align: center;">0</td> <td>Low-speed pulse</td> </tr> <tr> <td style="text-align: center;">1</td> <td>High-speed pulse</td> </tr> <tr> <td style="text-align: center;">2</td> <td>DI8</td> </tr> <tr> <td style="text-align: center;">3</td> <td>DI7</td> </tr> <tr> <td style="text-align: center;">D</td> <td>Duty-cycle correction mode</td> </tr> <tr> <td style="text-align: center;">0</td> <td>Close</td> </tr> <tr> <td style="text-align: center;">1</td> <td>Start</td> </tr> </table>	A	Reset source setting	0	Software	1	DI8	2	DI7	B	CAP command source setting	0	Software	1	DI8	2	DI7	C	Command source setting	0	Low-speed pulse	1	High-speed pulse	2	DI8	3	DI7	D	Duty-cycle correction mode	0	Close	1	Start
A	Reset source setting																																			
0	Software																																			
1	DI8																																			
2	DI7																																			
B	CAP command source setting																																			
0	Software																																			
1	DI8																																			
2	DI7																																			
C	Command source setting																																			
0	Low-speed pulse																																			
1	High-speed pulse																																			
2	DI8																																			
3	DI7																																			
D	Duty-cycle correction mode																																			
0	Close																																			
1	Start																																			
PL112	High-speed counter 2 compare register			<input type="checkbox"/> speed <input type="checkbox"/> position <input type="checkbox"/> torque																																
	Setting Range	Setting Unit	Mfr's Value	Effect																																
	-2147483647~+2147483647	N/A	0	Effective Immediately																																
PL114	High-speed counter 2 periodic value			<input type="checkbox"/> speed <input type="checkbox"/> position <input type="checkbox"/> torque																																
	Setting Range	Setting Unit	Mfr's Value	Effect																																
	-2147483647~+2147483647	N/A	0	Effective Immediately																																
PL116	High-speed counter 2 count value			<input type="checkbox"/> speed <input type="checkbox"/> position <input type="checkbox"/> torque																																
	Setting Range	Setting Unit	Mfr's Value	Effect																																
	-2147483647~+2147483647	N/A	0	Check																																
PL118	High-speed counter2 CAP value			<input type="checkbox"/> speed <input type="checkbox"/> position <input type="checkbox"/> torque																																
	Setting Range	Setting Unit	Mfr's Value	Effect																																
	-2147483647~+2147483647	N/A	0	Check																																
PL120	High-speed pulse control			<input type="checkbox"/> speed <input type="checkbox"/> position <input type="checkbox"/> torque																																
	Setting range	Setting unit	Mfr's value	When enabled																																
	Four-parameter	N/A	0000	Effective Immediately																																

FL20-SA Series

		<table border="1" style="width: 100%; border-collapse: collapse;"> <tr> <td style="text-align: center;">A</td> <td>High - speed pulse type</td> </tr> <tr> <td style="text-align: center;">0</td> <td>Direction + Pulse</td> </tr> <tr> <td style="text-align: center;">1</td> <td>Dipulse</td> </tr> <tr> <td style="text-align: center;">2</td> <td>Orthogonal pulse</td> </tr> <tr> <td style="text-align: center;">B</td> <td>High-speed pulse filtering</td> </tr> <tr> <td style="text-align: center;">0</td> <td>8MHz</td> </tr> <tr> <td style="text-align: center;">1</td> <td>4MHz</td> </tr> <tr> <td style="text-align: center;">2</td> <td>2MHz</td> </tr> <tr> <td style="text-align: center;">3</td> <td>1MHz</td> </tr> <tr> <td style="text-align: center;">4</td> <td>500KHz</td> </tr> <tr> <td style="text-align: center;">5</td> <td>200KHz</td> </tr> <tr> <td style="text-align: center;">6</td> <td>150KHz</td> </tr> <tr> <td style="text-align: center;">C</td> <td>High-speed pulse direction</td> </tr> <tr> <td style="text-align: center;">0</td> <td>HPULS anti-logic, HSIGN anti-logic</td> </tr> <tr> <td style="text-align: center;">1</td> <td>HPULS positive logic, HSIGN positive logic</td> </tr> <tr> <td style="text-align: center;">2</td> <td>HPULS anti-logic, HSIGN positive logic</td> </tr> <tr> <td style="text-align: center;">3</td> <td>HPULS positive logic, HSIGN anti-logic</td> </tr> <tr> <td style="text-align: center;">4</td> <td>Exchange HPULS and HSIGN</td> </tr> <tr> <td style="text-align: center;">D</td> <td>DI7/DI8 filter time</td> </tr> <tr> <td style="text-align: center;">0</td> <td>800KHz</td> </tr> <tr> <td style="text-align: center;">1</td> <td>400KHz</td> </tr> <tr> <td style="text-align: center;">2</td> <td>200KHz</td> </tr> <tr> <td style="text-align: center;">3</td> <td>100KHz</td> </tr> <tr> <td style="text-align: center;">4</td> <td>40KHz</td> </tr> <tr> <td style="text-align: center;">5</td> <td>30KHz</td> </tr> <tr> <td style="text-align: center;">6</td> <td>16KHz</td> </tr> <tr> <td style="text-align: center;">7</td> <td>8 KHz</td> </tr> <tr> <td style="text-align: center;">8</td> <td>4 KHz</td> </tr> </table>	A	High - speed pulse type	0	Direction + Pulse	1	Dipulse	2	Orthogonal pulse	B	High-speed pulse filtering	0	8MHz	1	4MHz	2	2MHz	3	1MHz	4	500KHz	5	200KHz	6	150KHz	C	High-speed pulse direction	0	HPULS anti-logic, HSIGN anti-logic	1	HPULS positive logic, HSIGN positive logic	2	HPULS anti-logic, HSIGN positive logic	3	HPULS positive logic, HSIGN anti-logic	4	Exchange HPULS and HSIGN	D	DI7/DI8 filter time	0	800KHz	1	400KHz	2	200KHz	3	100KHz	4	40KHz	5	30KHz	6	16KHz	7	8 KHz	8	4 KHz
A	High - speed pulse type																																																									
0	Direction + Pulse																																																									
1	Dipulse																																																									
2	Orthogonal pulse																																																									
B	High-speed pulse filtering																																																									
0	8MHz																																																									
1	4MHz																																																									
2	2MHz																																																									
3	1MHz																																																									
4	500KHz																																																									
5	200KHz																																																									
6	150KHz																																																									
C	High-speed pulse direction																																																									
0	HPULS anti-logic, HSIGN anti-logic																																																									
1	HPULS positive logic, HSIGN positive logic																																																									
2	HPULS anti-logic, HSIGN positive logic																																																									
3	HPULS positive logic, HSIGN anti-logic																																																									
4	Exchange HPULS and HSIGN																																																									
D	DI7/DI8 filter time																																																									
0	800KHz																																																									
1	400KHz																																																									
2	200KHz																																																									
3	100KHz																																																									
4	40KHz																																																									
5	30KHz																																																									
6	16KHz																																																									
7	8 KHz																																																									
8	4 KHz																																																									
PL121	Internal command source		<input type="checkbox"/> speed <input type="checkbox"/> position <input type="checkbox"/> torque																																																							
	Setting Range	Setting Unti	Mfr's Value Effect																																																							
	0~1	N/A	0 Effective Immediately																																																							
	0: Internal parameter PL100 1: Internal PLC																																																									
PL122	CAP1 indicating		<input type="checkbox"/> speed <input type="checkbox"/> position <input type="checkbox"/> torque																																																							
	Setting Range	Setting Unti	Mfr's Value Effect																																																							
	N/A	N/A	— —																																																							
PL123	CAP2 indicating		<input type="checkbox"/> speed <input type="checkbox"/> position <input type="checkbox"/> torque																																																							
	Setting Range	Setting Unti	Mfr's Value Effect																																																							
	N/A	N/A	— —																																																							
PL124	High-speed counter 1 increment		<input type="checkbox"/> speed <input type="checkbox"/> position <input type="checkbox"/> torque																																																							
	Setting Range	Setting Unti	Mfr's Value Effect																																																							
	N/A	N/A	— —																																																							
PL126	High-speed counter 2 increment		<input type="checkbox"/> speed <input type="checkbox"/> position <input type="checkbox"/> torque																																																							
	Setting Range	Setting Unti	Mfr's Value Effect																																																							

FL20-SA Series

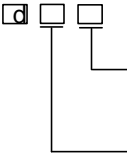
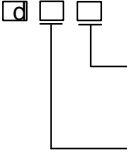
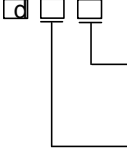
	N/A	N/A	—	—													
PL130	Low-speed Timer 1 Configuration			PLC													
	Setting Range	Setting Unit	Mfr's Value	Effect													
	Two-parameter	N/A	00	Effective Immediately													
	 <table border="1" data-bbox="672 381 959 460"> <thead> <tr> <th>X</th> <th>Timer Mode</th> </tr> </thead> <tbody> <tr> <td>0</td> <td>Reach set value and maintain</td> </tr> <tr> <td>1</td> <td>Reach set value and continue to count</td> </tr> </tbody> </table> <table border="1" data-bbox="672 468 959 569"> <thead> <tr> <th>Y</th> <th>Count Source</th> </tr> </thead> <tbody> <tr> <td>0</td> <td>10ms</td> </tr> <tr> <td>1</td> <td>100ms</td> </tr> <tr> <td>2</td> <td>PLC stores B448</td> </tr> </tbody> </table>				X	Timer Mode	0	Reach set value and maintain	1	Reach set value and continue to count	Y	Count Source	0	10ms	1	100ms	2
X	Timer Mode																
0	Reach set value and maintain																
1	Reach set value and continue to count																
Y	Count Source																
0	10ms																
1	100ms																
2	PLC stores B448																
PL131	Low-speed timer 2 Configuration			PLC													
	Setting Range	Setting Unit	Mfr's Value	Effect													
	Two-parameter	N/A	00	Effective Immediately													
	 <table border="1" data-bbox="672 763 959 841"> <thead> <tr> <th>X</th> <th>Timer Mode</th> </tr> </thead> <tbody> <tr> <td>0</td> <td>Reach set value and maintain</td> </tr> <tr> <td>1</td> <td>Reach set value and continue to count</td> </tr> </tbody> </table> <table border="1" data-bbox="672 850 959 951"> <thead> <tr> <th>Y</th> <th>Count Source</th> </tr> </thead> <tbody> <tr> <td>0</td> <td>10ms</td> </tr> <tr> <td>1</td> <td>100ms</td> </tr> <tr> <td>2</td> <td>PLC stores B449</td> </tr> </tbody> </table>				X	Timer Mode	0	Reach set value and maintain	1	Reach set value and continue to count	Y	Count Source	0	10ms	1	100ms	2
X	Timer Mode																
0	Reach set value and maintain																
1	Reach set value and continue to count																
Y	Count Source																
0	10ms																
1	100ms																
2	PLC stores B449																
PL132	Low-speed timer 3 Configuration			PLC													
	Setting Range	Setting Unit	Mfr's Value	Effect													
	Two-parameter	N/A	00	Effective Immediately													
	 <table border="1" data-bbox="672 1145 959 1223"> <thead> <tr> <th>X</th> <th>Timer Mode</th> </tr> </thead> <tbody> <tr> <td>0</td> <td>Reach set value and maintain</td> </tr> <tr> <td>1</td> <td>Reach set value and continue to count</td> </tr> </tbody> </table> <table border="1" data-bbox="672 1232 959 1333"> <thead> <tr> <th>Y</th> <th>Count Source</th> </tr> </thead> <tbody> <tr> <td>0</td> <td>10ms</td> </tr> <tr> <td>1</td> <td>100ms</td> </tr> <tr> <td>2</td> <td>PLC stores B450</td> </tr> </tbody> </table>				X	Timer Mode	0	Reach set value and maintain	1	Reach set value and continue to count	Y	Count Source	0	10ms	1	100ms	2
X	Timer Mode																
0	Reach set value and maintain																
1	Reach set value and continue to count																
Y	Count Source																
0	10ms																
1	100ms																
2	PLC stores B450																
PL133	Low-speed timer 4 Configuration			PLC													
	Setting Range	Setting Unit	Mfr's Value	Effect													
	Two-parameter	N/A	00	Effective Immediately													

FL20-SA Series

	<table border="1" style="margin-left: 20px;"> <tr><th>X</th><th>Timer Mode</th></tr> <tr><td>0</td><td>Reach set value and maintain</td></tr> <tr><td>1</td><td>Reach set value and continue to count</td></tr> </table> <table border="1" style="margin-left: 20px;"> <tr><th>Y</th><th>Count Source</th></tr> <tr><td>0</td><td>10ms</td></tr> <tr><td>1</td><td>100ms</td></tr> <tr><td>2</td><td>PLC stores B451</td></tr> </table>				X	Timer Mode	0	Reach set value and maintain	1	Reach set value and continue to count	Y	Count Source	0	10ms	1	100ms	2	PLC stores B451
X	Timer Mode																	
0	Reach set value and maintain																	
1	Reach set value and continue to count																	
Y	Count Source																	
0	10ms																	
1	100ms																	
2	PLC stores B451																	
PL140	Low-speed timer 1 set value [PLC]																	
	Setting Range	Setting Unit	Mfr's Value	Effect														
	-2147483647~+2147483647	N/A	0	Effective Immediately														
PL142	Low-speed timer 2 set value [PLC]																	
	Setting Range	Setting Unit	Mfr's Value	Effect														
	-2147483647~+2147483647	N/A	0	Effective Immediately														
PL144	Low-speed timer 3 set value [PLC]																	
	Setting Range	Setting Unit	Mfr's Value	Effect														
	-2147483647~+2147483647	N/A	0	Effective Immediately														
PL146	Low-speed timer 4 set value [PLC]																	
	Setting Range	Setting Unit	Mfr's Value	Effect														
	-2147483647~+2147483647	N/A	0	Effective Immediately														
PL150	Low-speed timer 1 current value [PLC]																	
	Setting Range	Setting Unit	Mfr's Value	Effect														
	-2147483647~+2147483647	N/A	—	Effective Immediately														
PL152	Low-speed timer 2 current value [PLC]																	
	Setting Range	Setting Unit	Mfr's Value	Effect														
	-2147483647~+2147483647	N/A	—	—														
PL154	Low-speed timer 3 current value [PLC]																	
	Setting Range	Setting Unit	Mfr's Value	Effect														
	-2147483647~+2147483647	N/A	—	—														
PL156	Low-speed timer 4 current value [PLC]																	
	Setting Range	Setting Unit	Mfr's Value	Effect														

FL20-SA Series

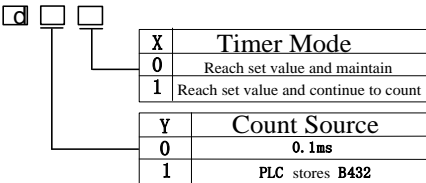
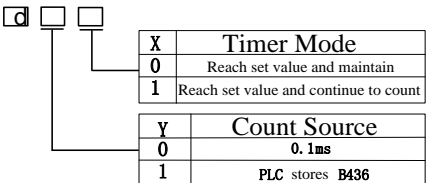
	-2147483647~+2147483647	N/A	—	—											
PL160	High-speed counter 1 set PLC														
	Setting Range	Setting Unit	Mfr's Value	Effect											
	Two-parameter	N/A	00	Effective Immediately											
	 <table border="1" style="margin-left: 20px;"> <tr><td>X</td><td>Timer Mode</td></tr> <tr><td>0</td><td>Reach set value and maintain</td></tr> <tr><td>1</td><td>Reach set value and continue to count</td></tr> </table> <table border="1" style="margin-left: 20px;"> <tr><td>Y</td><td>Count Source</td></tr> <tr><td>0</td><td>0.1ms</td></tr> <tr><td>1</td><td>PLC stores B432</td></tr> </table>				X	Timer Mode	0	Reach set value and maintain	1	Reach set value and continue to count	Y	Count Source	0	0.1ms	1
X	Timer Mode														
0	Reach set value and maintain														
1	Reach set value and continue to count														
Y	Count Source														
0	0.1ms														
1	PLC stores B432														
PL161	High-speed counter 1 set value PLC														
	Setting Range	Setting Unit	Mfr's Value	Effect											
	-2147483647~+2147483647	N/A	0	Effective Immediately											
PL163	High-speed counter 1 current value PLC														
	Setting Range	Setting Unit	Mfr's Value	Effect											
	-2147483647~+2147483647	N/A	—	—											
PL165	High-speed counter 2 set PLC														
	Setting Range	Setting Unit	Mfr's Value	Effect											
	Two-parameter	N/A	00	Effective Immediately											
	 <table border="1" style="margin-left: 20px;"> <tr><td>X</td><td>Timer Mode</td></tr> <tr><td>0</td><td>Reach set value and maintain</td></tr> <tr><td>1</td><td>Reach set value and continue to count</td></tr> </table> <table border="1" style="margin-left: 20px;"> <tr><td>Y</td><td>Count Source</td></tr> <tr><td>0</td><td>0.1ms</td></tr> <tr><td>1</td><td>PLC stores B436</td></tr> </table>				X	Timer Mode	0	Reach set value and maintain	1	Reach set value and continue to count	Y	Count Source	0	0.1ms	1
X	Timer Mode														
0	Reach set value and maintain														
1	Reach set value and continue to count														
Y	Count Source														
0	0.1ms														
1	PLC stores B436														
PL166	High-speed counter 2 set value PLC														
	Setting Range	Setting Unit	Mfr's Value	Effect											
	-2147483647~+2147483647	N/A	0	Effective Immediately											
PL168	High-speed counter 2 current value PLC														
	Setting Range	Setting Unit	Mfr's Value	Effect											
	-2147483647~+2147483647	N/A	—	—											
PL170	PLC Start Function			PLC											

FL20-SA Series

	Setting Range	Setting Unit	Mfr's Value	Effect
	0~1	N/A	0	Effective Immediately
	0: Not start PLC function; 1: Start PLC function;			
PL172	PLC Start Adress PLC			
	Setting Range	Setting Unit	Mfr's Value	Effect
	0~2000	N/A	0	Effective Immediately
PL174	PLC Reset PLC			
	Setting Range	Setting Unit	Mfr's Value	Effect
	0~1	N/A	0	Effective Immediately
	0: Not reset PLC function; 1: Reset PLC function;			
PL199	Download of E-cam and PLC data PLC			
	Setting Range	Setting Unit	Mfr's Value	Effect
	0~1	N/A	0	Effective Immediately
	When user refreshes cam table with PLC, if communication mode is adopted, user must set 1 to address 1199, input cam table data, set cam table points (more than 5) to address 1015 and set 1 to address 1017.			

8.1.7 Function setting of DI and DO

Programmable terminals include DI1~DI8. (The related parameters are from Po407 to Po414).

Input contactor type is used to select common-open or common-close interface type. For example, when some malfunction occurs, servo drive must stop safely, which needs the common-close switch.

 After changing these parameters, turn OFF the main circuit and control power supplies and then turn them ON again to enable the new settings.

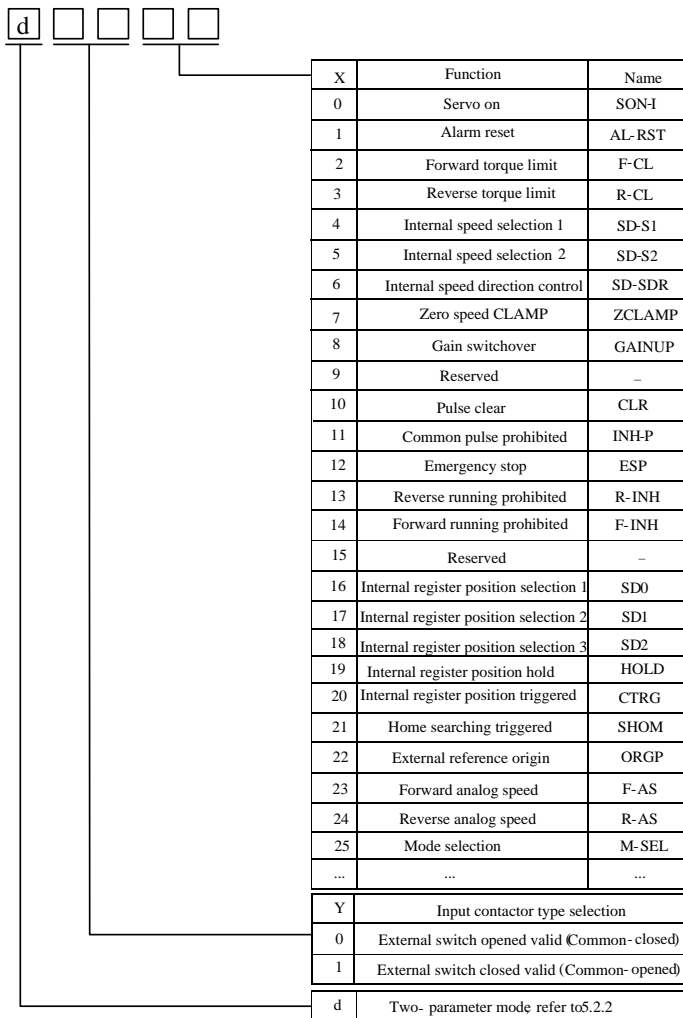



Fig 8.1.1 Setting programmable input terminal function

Setting value	Function	Name	Instruction	Signal type
0	Servo on	SON-I	Servo on. Switch servo to “servo ready”	Level trigger
1	Alarm reset	AL-RST	A number of faults (Alarms) can be cleared by activating AL-RST.	Edge trigger
2	Forward torque limit	F-CL	Servo drive output torque when motor is forbidden forward run.	Level trigger
3	Reverse torque limit	R-CL	Servo drive output torque when motor is forbidden reverse run.	Level trigger
4	Internal speed selection 1	SD-S1	The combination of internal speed selection 1 and internal speed selection 2 gets four kinds of internal speed.	Level trigger
5	Internal speed selection 2	SD-S2		
6	Internal speed direction control	SD-DIR	Motor run direction is controlled by SD-DIR at the mode of internal register speed.	Level trigger
7	Zero speed CLAMP	ZCLAMP	When the absolute value of speed is lower than the value of zero speed CLAMP, the motor speed is 0 and position is locked.	Level trigger
8	Gain switchover	GAIN-SEL	Gain switchover	Level trigger
9	Internal position mode stop	STOP	Internal position mode stop	Edge trigger
10	Pulse clear	CLR	Position deviation register returns to 0 at the position mode.	Edge trigger
11	Command pulse prohibited	INH-P	External pulse command is invalid at the position mode.	Level trigger
12	Emergency stop	ESP	Motor stops urgently.	Level trigger
13	Reverse run prohibited	R-INH	Motor is forbidden reverse run.	Level trigger
14	Forward run prohibited	F-INH	Motor is forbidden forward run.	Level trigger
15	–	–	Reversed	Level trigger
16	Internal register position selection 1	SD0	Internal register position selection	Level trigger
17	Internal register position selection 2	SD1	Internal register position selection	Level trigger
18	Internal register position selection 3	SD2	Internal register position selection	Level trigger

19	Internal register position hold	HOLD	The present position command is hold when internal register position hold is valid. If this command is invalid, keep executing the present position command.	Edge trigger
20	Internal register position triggered	CTRG	Internal register position triggered mode	Edge trigger
21	Home searching triggered	SHOM	Home searching triggered mode	Edge trigger
22	External reference origin	ORGP	ORGP is external reference origin.	Edge trigger
23	Analog speed forward	F-AS	Realized by controlling terminal.	Level trigger
24	Analog speed reverse	R-AS	Realized by controlling terminal.	Level trigger
25	Mode switchover	M-SEL	Realized by controlling terminal.	Level trigger
26	Terminal forward jogging	JOGU	Realized by controlling terminal.	Level trigger
27	Terminal reverse jogging	JOGD	Realized by controlling terminal.	Level trigger
28	Motor overheat	HOT	Realized by controlling terminal.	Level trigger
29	Interruption of fixed length trigger	XintTrig	When interruption enabled terminal is valid, rising edge triggers internal register position mode.	Level trigger
30	Interruption of fixed length reset	XintRest	Enable system to respond new interruption.	Edge trigger
31	Gantry synchronous start	GAN-SYNC	Gantry synchronous start	Level trigger
32	Electric cam act	CAM-ACT	Realized by controlling terminal	Level trigger
33	Electric cam selection	GEAR_SEL		Level trigger

Programmable output terminals include terminals from DO1 to DO4 (The related parameters are from Po421 to Po424), ALM (The related parameter is Po425).

 After changing these parameters, turn OFF the main circuit and control power supplies and then turn them ON again to enable the new settings.

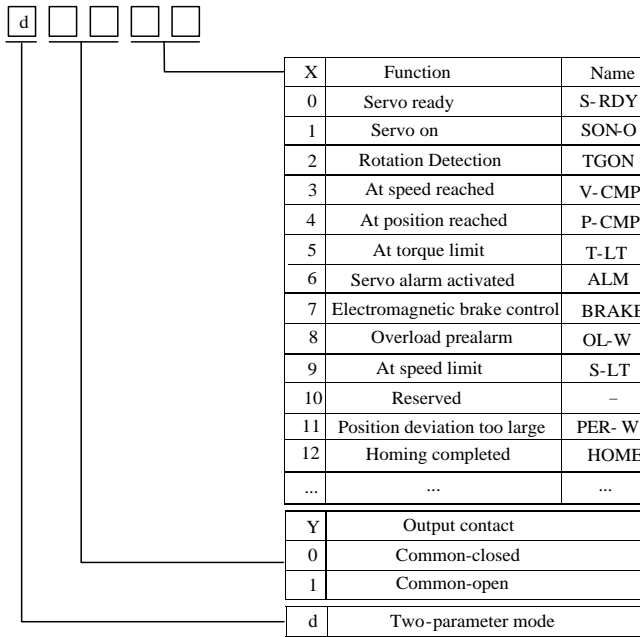

Fig 8.1.2 Setting programmable input terminal function

Function instruction of programmable output terminal:

Setting value	Function	Name	Instructions
0	Servo ready	S-RDY	S-RDY is activated when the servo drive is ready to run. All fault and alarm conditions, if present, have been cleared.
1	Servo on	SON-O	SON-O is activated when the servo motor is ON.
2	Rotation Detection	TGON	When the absolute value of speed is higher than the value of at rotation detection, TGON is activated.
3	At speed reached	V-CMP	V-CMP is activated when the servo motor has reached the target rotation speed.
4	At position reached	P-CMP	Position completed
5	At torque limit	T-LT	T-LT is activated when torque is limited.
6	Servo alarm activated	ALM	ALM is activated when the drive has detected a fault condition.
7	Electromagnetic brake control	BRAKE	BRAKE is activated actuation of motor brake.
8	Overload pre-alarm	OL-W	Overload pre-alarm signal
9	At speed limit	S-LT	S-LT is activated when speed is limited.

10	Internal position triggered	CTRGING	CTRGING is activated when internal position trigger is applied.
11	Position deviation too large	PER-W	PER-W is activated when position deviation is too large.
12	Homing completed	HOME	HOME is activated when the servo drive has detected that the HOME sensor has been detected.
13	Reserved		Reserved
14	Electric cam act	CAM_AC	CAM_AC is activated when electric cam act.

IX Maintenance and Inspection

9.1 Alarm and Trouble shooting at start

9.1.1 Position control mode

Start-up process	Description	Cause	Countermeasures
Connect control power (L1C,L2C) and main power supply (R/L1 ,S/L2, T/L3)	Digital tube is not lighted or green light is not lighted	1.Control terminal is disconnected	<ul style="list-style-type: none"> ▪ Rewire ▪ Connect L1C/L2C power cable to socket separately.
		2.Control power supply fault	<ul style="list-style-type: none"> ▪ Check the voltage between L1C and L2C Note: 380V servo drive doesn't need to connect to L1C and L2C.
		3. Servo drive fault	Please contact with manufacturer.
	Keypad panel displays 'AL-XXX'	Refer to chapter 9.2 to find the cause and solve the problem.	
Servo drive enabled signal is valid (/S-ON is ON)	Servo motor is in unlocked state	1. Servo drive enabled signal is invalid	<ul style="list-style-type: none"> ▪ Check whether green light is on, if it is not on, take the following step. ▪ Check whether Po004=0, if it is not, set 0 to Po004 and repower on. ▪ Check whether Lo-15.A is 1, if it is not, check whether wiring is correct.
		2. Control mode is wrong	<ul style="list-style-type: none"> ▪ Check whether Po001.X is correct.
Input position command	Servo motor doesn't rotate	Lo-08 has no change.	<ul style="list-style-type: none"> ▪ High/low speed pulse interface is connected wrong. When user sets pulse command source to Po374, please check the wiring for high/low speed pulse interface, referring

			<p>to chapter 4.</p> <p>No position command is input</p> <ol style="list-style-type: none"> Whether DI function 2 (forward torque limit) or DI function 3 (reverse torque limit) is used. Whether DI function 11 (common pulse prohibited) is used. Check whether Po374 is set correctly.
	Servo motor is galloping.		<ul style="list-style-type: none"> ▪ Encoder cable fault <ol style="list-style-type: none"> Check whether Lo-04 value is correct when motor rotates 1 revolution. Check whether servo drive trips into AL-17 <ul style="list-style-type: none"> ▪ U/V/W motor cable fault. Check whether U/V/W wiring is correct. If wiring is correct, please study motor angle referring to chapter 7.2.
Rotation is not smooth at low speed.	Low speed rotation is not smooth.	Gain is not set properly.	<ul style="list-style-type: none"> ▪ Adjust gain according to chapter 7.
	Motor shaft vibrates side to side.	Rotation inertia ratio (Po013) is too high.	<ul style="list-style-type: none"> ▪ If servo drive runs safely, please recognize inertia again according to chapter 7.3. ▪ Adjust gain according chapter 7.
Normally running	Location is not accurate.	There is position error.	<ul style="list-style-type: none"> ▪ Pulse received by Lo-08 is not same as the one sent by PC/PLC.. <ol style="list-style-type: none"> Check whether servo drive grounding is reliable. Check whether signal cable is twisted-pair shield cable, whether shielding layer is connected to housing correctly. <ul style="list-style-type: none"> ▪ Check whether motor shaft coupler is locked tightly. ▪ Check whether device has vibration. Adjust the gain according to chapter 7.

9.1.2 Speed control mode

Start-up process	Description	Cause	Countermeasures
Connect control power(L1C,L2C) and main power supply(R/L1 ,S/L2, T/L3)	Digital tube is not on or green light is not on	1. Control terminal is disconnected	<ul style="list-style-type: none"> ▪ Rewire ▪ Connect L1C/L2C power cable to socket separately.
		2.Control power supply fault	<ul style="list-style-type: none"> ▪ Check the voltage between L1C and L2C ▪ Note: 380V servo drive doesn't need to connect to L1C and L2C.
		3.Servo drive fault	Please contact with manufacturer.
	Keypad Panel displays 'AL-XXX'.	Refer to chapter 9.2 to find the cause and solve the problem.	
Servo drive enabled signal is valid (/S-ON is ON)	Keypad Panel displays 'AL-XXX'.	Refer to chapter 9.2 to find the cause and solve the problem.	
	Servo motor is in unlocked state	1. Servo drive enabled signal is invalid	<ul style="list-style-type: none"> ▪ Check whether green light is on, if it is not, take the following step. ▪ Check whether Po004=0, if it is not, set 0 to Po004, then repower on. ▪ Check whether Lo-15.A is 1, if it is not, check whether wiring is correct.
2.Control mode is wrong		<ul style="list-style-type: none"> ▪ Check whether Po001.X is correct. 	
Input position command	Servo motor doesn't rotate or speed is not correct.	1. Lo-12 has no change. 2. Forward and reverse running is prohibited.	<ul style="list-style-type: none"> ▪ Analog interface wiring is wrong. Before setting command source to Po428, check whether analog wiring is correct , referring to chapter 4. ▪ No speed command is input. 1. Whether DI function 2 (forward torque limit) or DI function 3(reverse torque limit) is used. 2. Whether DI function 11 (common pulse prohibited) is used. 3. Check whether Po428 is set correctly. 4. Check whether Po113, Po114, Po115 is zero when digital command is given.
	Servo motor is galloping.		<ul style="list-style-type: none"> ▪ Encoder cable fault 1. Check whether Lo-04 value is correct when motor rotates 1 revolution. 2. Check whether servo drive trips into AL-17 <ul style="list-style-type: none"> ▪ U/V/W motor cable is wrong 1. Check whether U/V/W wiring is correct. 2. If wiring is correct, please study motor angle referring to chapter 7.2.
Rotation is not smooth at low	Rotation is not smooth at low speed.	Gain is set improperly.	<ul style="list-style-type: none"> ▪ Adjust gain according to chapter7.

speed.	Motor shaft vibrates side to side.	Rotation inertia ratio of load (Po013) is too high.	<ul style="list-style-type: none"> ▪ If servo drive runs safely, please recognize inertia again according to chapter 7.3. ▪ Adjust gain according chapter 7.
--------	------------------------------------	---	--

9.1.3 Torque control mode

Start-up process	Description	Cause	Countermeasures
Connect control power(L1C,L2C) and main power supply(R/L1 ,S/L2, T/L3)	Digital tube is not on or green light is not on	1. Control terminal is disconnected	<ul style="list-style-type: none"> ▪ Rewire ▪ Connect L1C/L2C power cable to socket separately.
		2.Control power supply fault	<ul style="list-style-type: none"> ▪ Check the voltage between L1C and L2C ▪ Note: 380V servo drive doesn't need to connect to L1C and L2C.
		3.Servo drive fault	Please contact with manufacturer.
	Keypad panel displays 'AL-XXX'.	Refer to chapter 9.2 to find the cause and solve the problem.	
Servo drive enabled signal is valid (/S-ON is ON)	Keypad panel displays 'AL-XXX'.	Refer to chapter 9.2 to find the cause and solve the problem.	
	Servo motor is in unlocked state.	1. Servo drive enabled signal is invalid	<ul style="list-style-type: none"> ▪ Check whether green light is on, if it is not, take the following step. ▪ Check whether Po004=0, if it is not, set 0 to Po004, then repower on. ▪ Check whether Lo-15.A is 1, if it is not, check whether wiring is correct.
		2.Control mode is wrong	<ul style="list-style-type: none"> ▪ Check whether Po001.X is correct.
Input torque command	Servo motor doesn't rotates or speed is not correct.	1. Lo-13 has no change. 2. Forward and reverse running is prohibited.	<ul style="list-style-type: none"> ▪ Analog interface wiring is wrong. Check whether analog wiring is correct when set command source by Po428, referring to chapter 4. ▪ No speed command is input. 1. Check whether DI function 2 (forward torque limit) or DI function 3(reverse torque limit) is used. 2. Check whether DI function 11 (common pulse prohibited) is used. 3. Check whether Po429 is set correctly. 4.Check whether Po204 is zero when digital command is given.
	Servo motor is galloping.		<ul style="list-style-type: none"> ▪ Encoder cable fault 1. Check whether Lo-04 value is correct when motor rotates 1 revolution. 2. Check whether servo drive trips into AL-17 <ul style="list-style-type: none"> ▪ U/V/W motor cable is wrong

			<ol style="list-style-type: none"> 1. Check whether U/V/W wiring is correct. 2. If wiring is correct, study motor angle, referring to chapter 7.2.
Rotation is not smooth at low speed.	Rotation is not steady at low speed.	Gain is set improperly.	<ul style="list-style-type: none"> ▪ Adjust gain according to chapter 7.
	Motor shaft vibrates side to side.	Rotation inertia ratio (Po013) is too high.	<ul style="list-style-type: none"> ▪ If servo drive runs safely, please recognize inertia again according to chapter 7.3. Adjust gain according chapter 7.

9.2 Alarm code and possible cause

Code	Alarm code	Alarm name	Possible Cause
1	AL-01	Overcurrent	Output short-circuit or module malfunction
2	AL-02	Overvoltage	Main circuit DC voltage is too high.
3	AL-03	Undervoltage	Main circuit DC voltage is too low
4	AL-04	Hardware fault	Hardware failure inside drive
5	AL-05	Electric angle recognition error	Motor line sequence error
6	AL-06	Overload	High current is output for long time.
7	AL-07	Overspeed	Speed is too high
8	AL-08	Reserved	—
9	AL-09	Large position control error	Position loop trace error overflow
10	AL-10	Encoder fault	Servo motor failure
11	AL-11	Emergency stop	External emergency stop terminal is valid
12	AL-12	Servo drive overheat	Temperature of servo drive radiator is too high
13	AL-13	Input phase loss	In the state of power supply connection of main circuit, the voltage of one phase in three-phase power supply is too low.
14	AL-14	Regenerative braking error	Brake parameters aren't set correct or continuous brake time is too long.
15	AL-15	—	—
16	AL-16	Repeat setting of input terminal	Repeat setting of input terminal
17	AL-17	Disconnected encoder cable	Disconnection of servo encoder line
18	AL-18	Rotary inertia recognition fault	Alarm when wrong rotary inertia recognition
19	AL-19	Alarm of encoder battery	Battery alarm of servo encoder
20	AL-20	Uninitialized E2ROM	Uninitialized of E2ROM for servo motor
21	AL-21	Large zero drift	Servo drive zero drift is too large
22	AL-22	Z signal lost	Z signal is not detected after encoder rotates 3

			times continuously.
23	AL-23	——	——
24	AL-24	Battery undervoltage	Encoder battery undervoltage
25	AL-25	Motor overheat	Motor temperature is too high.
26	AL-26	Disconnected temperature detection circuit	Temperature detection circuit is disconnected
27	AL-27	Overtravel	Overtravel alarm
28	AL-28	E2ROM error	E2ROM error
29	AL-29	Ground protection	Ground protection
30	AL-30	Motor locked-rotor protection	Locke-totor happens when motor running
31	AL-31	Large mixed error of full closed-loop	Mixed error of full closed-loop is too large
32	AL-32	Synchronism error of gantry	Gantry drive is not synchronous.
33	AL-33	Electronic cam error	Electronic cam error
34	AL-34	PLC command error	PLC command error
35	AL-35	Home searching overtime	Homing search is overtime
36	AL-36	Parameter copy error	Parameter copy error
37	AL-41	high-impedance state not detected	High-impedance state output is not detected after 8-core encoder is powered on.

9.3 Alarm Display Table and Trouble shooting

<h2 style="margin: 0;">Attention</h2>
<ul style="list-style-type: none"> ★ When malfunction occurs to servo drive, do not run by resetting immediately. Check any causes and get it removed if there is any. ★ Take counter measures by referring to this manual in case of any malfunctions on drive. Should it still be unsolved, contact with local Parker agent or Parker manufacturer. Never attempt any repairing without authorization.

Alarm Code	Alarm Name	Possible Cause	Treatment
AL-01	Overcurrent	Main circuit wiring error	Check the wiring.
		Output short-circuit	Cable is short-circuit, fix or exchange it.
		Short-circuit inside of servo drive or grounding short-circuit	Fix or exchange servo drive.
		Wrong action because of interference	Adopt anti-interference methods, improve wiring, etc.
		Servo drive is damaged.	Fix or exchange servo drive

AL-02	Overvoltage	Input voltage is too high	Check input voltage.
		Load rotary inertia too large	Prolong deceleration time
			Add external braking resistor
			Reduce load.
		Increase drive capacity.	
AL-03	Undervoltage	Input voltage is low	Check input voltage. Check whether main circuit is powered on.
AL-04	Hardware fault	Hardware fault	Contact with Parker.
AL-05	Electric angle recognition error	Motor line sequence error	Adjust line sequences, exchange two of them.
AL-06	Overload	Servo motor or encoder wiring is bad.	Check the wiring of servo motor and encoder.
		Machanical factors	Check the transmission ratio of mechanical equipments.
		Servo drive runs when electromagnetic brake is not released	Check the wiring of electromagnetic brake.
		Heavy load	Reduce load. Increase capcity of drive.
AL-07	Overspeed	Servo motor rotary speed is higher than max speed	Servo motor wiring, encoder wiring or mechanical fault.
AL-08	Reserved		
AL-09	Large position control error	U, V, W or encoder connection error or connector contact is bad	Improve connection.
		Servo Drive gain is low.	Increase gain, adjust gain of speed and position
		The frequency of position pulse is too high	Reduce pulse frequency or adjust electronic gear
AL-10	Encoder fault	Disconnected encoder or servo motor is locked-rotor	Check encoder connection
		Servo motor fault	Power on again, if alarm still occurs, please contact with Parker.
AL-11	Emergency stop	Logic of ESP input terminal is not corresponding to connection.	Check connection or modify terminal logic.
		Hardware damage of ESP input terminal	Set the function to other input terminal or contact with Parker.
AL-12	Servo drive overheat	Enviroment temperature is too high	Improve ventilation.
		Dirty radiator	Clean air outlet and cooling radiator.
		Foreign matter in fan	Clear fan.
		Fan damage	Exchange fan.

		Improper installation of drive, such as poor ventilation or wrong install direction.	Install as required.
		Too heavy load	
		Discharge energy is too large	
AL-13	Input phase loss	Phase loss with input phase	Check input power supply.
		Use single-phase power supply.	Check parameter setting
AL-14	Regenerative braking error	Wrong braking resistor parameter	Change parameter.
		Continuous brake time is too long	Check load, servo only can drive non-potential energy load.
AL-16	Repeat setting of input terminal	Repeat setting of input terminal	Reset input terminal.
AL-17	Disconnected encoder cable	Disconnected encoder cable	Disconnected or damage of encoder cable
AL-18	Rotary inertia recognition fault	Rotary inertia recognition fault	Turn up Po013 manually.
AL-19	Alarm of encoder battery	Alarm of encoder battery	<p>1. Check if encoder cable is connected well. If it is disconnected, reconnect it and reset alarm.</p> <p>2. Check if battery level is 3.6V. If level is lower than 3.2V, keep control power at "ON" state,</p> <p>3. Shield AL-19: So-38=1, So-43=1 reset alarm.</p> <p>4. Check if connecton of battery is reliable.</p>
AL-20	Uninitialized E2ROM	Unintialized E2ROM of servo motor	Servo motor encoder is not initialized, please study motor angle manually.
AL-21	Large zero drift	Servo drive zero drift is too large	Check wiring or parameter setting.
AL-22	Z signal lost	Z signal is not detected after encoder rotates 3 times continuously.	Check encoder and Z signal cable.
AL-23	Reserved		
AL-24	Encoder battery undervoltage	Encoder battery undervoltage	<p>1. If encoder battery is undervoltage, AL-24 will occur leading to enoder position loss. Reset mechanical origin to eliminate.</p> <p>2. Shield AL-24: So-48=1, So-41=1(set current position as machnical origin), So-43=1 reset alarm, PC/PLC will reset the mechanical origin.</p>
AL-25	Motor overheat	Motor temperature is too high.	Improve ventilation

AL-26	Temperature detection circuit is disconnected	Temperature detection circuit is disconnected	Check the cable.
AL-27	Overtravel	Overtravel alarm	Setting range of FWD/FEV for overtravel protection again.
AL-28	E ² ROM error	E2ROM error	Contact with Parker.
AL-29	Ground protection	Ground protection	Electric leakage of drive power port or servo motor output port.
AL-30	Motor locked-rotor protection	Motor locked-rotor	<ol style="list-style-type: none"> 1. Check if mechanical structure is blocked 2. Check if power cable is loosen 3. Locked-rotor 4. Load is too heavy, exceeding motor allowed torque; 5. Motor power cable is wired wrong.
AL-31	Large mixed error of full closed-loop	Po377, Po378 and Po380 are not set properly.	Check Po377, Po378 and Po380.
		Transmission part is not fastened	Check the transmission part
		U, V, W terminal, encoder connection or connector contact is not good.	Check the connection of servo motor and encoder
		Wrong connection of encoder at mechanical terminal	Check the connection of encoder at mechanical terminal
		Drive gain is low	Increase gain, adjust the gain of speed and position
		The frequency of position pulse is too high	Reduce pulse frequency or adjust electronic gear
AL-32	Synchronism error of gate bridge	Po383, Po384 and Po386 are not set properly.	Check Po383, Po384 and Po386.
		Transmission part is not fastened	Check the transmission part
		Servo drive receives wrong pulse	Check if the wiring of servo drive is correct and PC/PLC send correct command.
AL-33	Electric cam error	Electric cam data error	Check whether electric cam data is correct.
AL-34	PLC commmand error	PLC commmand error	Check whether PLC command is correct.
AL-35	Home searching overtime	Home searching overtime	Check the wiring.
			Check the servo drive.
AL-36	Parameter copy error	Parameter copy error	Check the wiring .
			Check the parameter setting.
AL-41	high-impedance state not detected	High-impedance state output is not detected after 8-core encoder is powered on.	Check 8-core encoder.
			Contact with Parker.

9.3.1 Other malfunctions

Malfunction	Cause	Measure
Servo motor does not run.	Main circuit power supply is disconnected.	Check the wiring.
	Control circuit power supply is disconnected.	Check the wiring.
	The wiring of I/O terminal is wrong.	Check the wiring.
	The wiring of servo motor or encoder is wrong.	Check the wiring.
	Control command is not inputted.	Input control command correctly.
	Some wrong using of input/output terminal. For example: servo on terminal is disconnected or it is defined wrong.	Define and use control terminal correctly.
	Forward/reverse rotation prohibited.	Make the function of forward/reverse rotation prohibited invalid.
	Torque limited.	Check the parameters of torque limited function.
	Servodrive fault.	Maintain or replace servodrive.
Servo motor moves instantaneously and then Stops	Servo motor wiring is incorrect.	Check the wiring.
	Servodrive fault.	Please contact with Parker.
Abnormal noise from servo motor	Mounting not secured	Check the mounting screws and tighten them.
		Align the couplings.
	Wrong parameters setting	Check servodrive parameters.
	Defective bearings	Replace the servo motor.
	Driven machine fault	Check whether there are any foreign matters, damages or deformation on the machine section.
	Encoder fault	Check whether the cable of encoder is damaged.

X Communication

10.1 Communication

Servo drive provides RS485 communication. The description below shows the communication wiring and communication protocol.

10.1.1 MODBUS General

Modbus is a serial and asynchronous communication protocol. Modbus protocol is a general language applied to PLC and other controlling units. This protocol has defined an information structure which can be identified and used by a controlling unit regardless of whatever network they are transmitted.

You can read reference books or ask for the details of MODBUS from Parker..

Modbus protocol does not require a special interface while a typical physical interface is RS485.

10.1.2 MODBUS Protocol

1 Transmission mode

(1) ASCII mode

In ASCII mode, one Byte (hexadecimal format) is expressed by two ASCII characters.

For example, 31H (hexadecimal data) includes two ASCII characters '3(33H)', '1(31H)'.

Common characters, ASCII characters are shown in the following table:

Characters	'0'	'1'	'2'	'3'	'4'	'5'	'6'	'7'
ASCII Code	30H	31H	32H	33H	34H	35H	36H	37H
Characters	'8'	'9'	'A'	'B'	'C'	'D'	'E'	'F'
ASCII Code	38H	39H	41H	42H	43H	44H	45H	46H

(2) RTU mode

In RTU mode, one Byte is expressed by hexadecimal format. For example, 31H is delivered to data packet.

2 Baud rate

Setting range: 2400, 4800, 9600, 19200, 38400, 57600

3 Frame structure:

(1) ASCII mode

Byte	Function
1	Start Bit (Low Level)
7	Data Bit
0/1	Parity Check Bit (None for this bit in case of no checking. Otherwise 1 bit)
1/2	Stop Bit (1 bit in case of checking, otherwise 2 bits)

(2) RTU mode

Byte	Function
1	Start Bit (Low Level)
8	Data Bit
0/1	Parity Check Bit (None for this bit in case of no checking. Otherwise 1 bit)
1/2	Stop Bit (1 bit in case of checking, otherwise 2 bits)

4 Error Check

(1) ASCII mode

Longitudinal Redundancy Check (LRC): It is performed on the ASCII message field contents excluding the 'colon' character that begins the message, and excluding the CRLF pair at the end of the message.

The LRC is calculated by adding together successive 8-bit bytes of the message, discarding any carries, and then two's complementing the result.

A procedure for generating an LRC is:

1. Add all bytes in the message, excluding the starting 'colon' and ending CRLF. Add them into an 8-bit field, so that carries will be discarded.
2. Subtract the final field value from FF hex (all 1's), to produce the ones-complement.
3. Add 1 to produce the two's-complement.

(2) RTU mode

CRC-16 (Cyclical Redundancy Check), please read reference books or ask for the details from Parker..

II Command Type & Format

1 The listing below shows the function codes.

Code	Name	Description
03	Read Holding Registers	Read the binary contents of holding registers in the slave. (Less than 10 registers once time)
06	Preset Single Register	Preset a value into holding register
16	Preset Multiple Register	Preset values into successive registers (1~120 registers) Note: In ASCII mode, register number must be less than 40. In RTU mode, register number must be less than 100.

2 Format

(1) ASCII mode

Start	Address	Function	Data				LRC check		End	
: (0X3A)	Servo drive Address	Function Code	Data length	Data 1	...	Data N	High-order byte of LRC	Low-order byte of LRC	Return (0X0D)	Line Feed (0X0A)

(2) RTU mode

Start	Address	Function	Data	CRC check		End
T1-T2-T3-T4	Servo drive Address	Function Code	N data	Low-order byte of CRC	High-order byte of CRC	T1-T2-T3-T4

(3) Protocol Converter

It is easy to turn a RTU command into an ASCII command followed by the lists:

- 1) Use the LRC replacing the CRC.
- 2) Transform each byte in RTU command into a corresponding two byte ASCII. For example: transform 0x03 into 0x30, 0x33 (ASCII code for 0 and ASCII code for 3).
- 3) Add a 'colon' (:) character (ASCII 3A hex) at the beginning of the message.
- 4) End with a 'carriage return - line feed' (CRLF) pair (ASCII 0D and 0A hex).

So we will introduce RTU Mode in followed part. If you use ASCII mode, you can use the up lists to convert.

3 Parameter address rules

The address of P group parameters is the parameter numbers.

Ex1: communication address of Po101:

The parameter numbers of Po101 is 101, the hex format is 0x0065. The address of high bit is 0x00 and the address of low bit is 0x65.

Ex2: communication address of Po407:

The parameter numbers of Po407 is 407, the hex format is 0x0197. The address of high bit is 0x01 and the address of low bit is 0x97.

The address of S group parameters equals to parameter numbers +800

Ex3: communication address of So-02:

The parameter numbers of So-02 is 02, so the address of So-02 is 802, the hex format is 0x0322. The address of high bit is 0x03 and the address of low bit is 0x22.

A part of L group data is 32-bit data, please refer to following table:

Communication address	Meaning	Communication address	Meaning
900	Servodrive output current low 16 bits	923	Bit mode, low 8 bits stands for DI8~DI1 status.(Note)
901	Servodrive output current high16 bits	924	Reserved
902	Servodrive bus voltage low 16 bits	925	Bit mode, low 8 bits stands for DO8~DO1 status.(Note)
903	Servodrive bus voltage high 16 bits	926	Bit mode, alarm code (Note)
904	Servo motor rotation speed low 16 bits	927	Reserved
905	Servo motor rotation speed high16 bits	928	Reserved
906	Servo motor feedback pulse numbers low 16 bits	936	Servo motor absolution position pulse numbers high16 bits
907	Servo motor feedback pulse numbers high 16 bits.	937	Servo motor absolution position pulse numbers low16 bits
908	Servo motor feedback rotation low 16 bits	938	Servo motor absolution position rotation high16 bits
909	Servo motor feedback rotation high 16 bits	939	Servo motor absolution position rotation low 16 bits
910	Given pulse numbers low 16 bits	940	Bit mode, alarm code (bit0-bit15)
911	Given pulse numbers high 16 bits	941	Bit mode, alarm code (bit16-bit31)
912	Pulse counting deviation low16 bits	942	Bit mode, alarm code (bit32-bit47)
913	Pulse counting deviation high 16 bits	943	Reserved
914	Given speed low 16 bits	952	Actual absolute position (bit0-bit15)
915	Given speed high16 bits	953	Actual absolute position (bit16-bit31)
916	Given torque low 16 bits	954	Actual absolute position (bit32-bit47)
917	Given torque high 16 bits	955	Actual absolute position (bit48-bit63)
918	Analog speed low 16 bits	956	Actual absolute position(divided by electric gear ratio) (bit0-bit5)
919	Analog speed high 16 bits	957	Actual absolute position (divided by electric gear ratio bit6-bit31)
920	Analog torque low 16 bits	958	Actual absolute position (divided by electric gear ratiobit32-bit47)
921	Analog torque high 16 bits	959	Actual absolute position(divided by electric gear ratio) (bit48-bit63)
922	Reserved	964	Fault code

Note: please refer to 4 Reading and writing rules of parameters about bit mode.

Ex4: The address of servo motor feedback pulse numbers

From the above table, the address of servo motor feedback pulse includes high 16 bits (Communication address is 906, the hex form is 0x038A) and low 16 bits(Communication address is 907, the hex form is 0x038B). Read the data from the address and process them.

4 Reading and writing rules of parameters

Except two-parameter and four-parameter, the other parameters can be read directly, the data is 16-bit integer (it is complement form).

Concerning for two-parameter and four-parameter, the written and read value is hexadecimal format (The marking bits of d and b do not occupy communication bit). Under line “_” means that the bit is not displayed.

Ex5: Two-parameter mode is d_1_10, so the hex format is 0x10A, so the read result is 266.

Ex6: Four-parameter mode is b1234, so 0x1234 is written, and b1234 is displayed after the order succeeds.

The special instructions for 32-bit data are as the following.

Ex7: Read servo motor feedback pulse numbers. Separately read high 16-bit and low 16-bit parameters value, shift high 16-bit data 16 bits to the left, and execute OR with low 16-bit, and confirm positive and negative according to the highest bit 0 or 1. If the highest bit is 0, the data is actual servo motor feedback pulse numbers and the data is positive number. If the highest bit is 1, to negate every bit and to add 1 to them, which equals to servo motor feedback pulse numbers and it is a negative number. If high 16 bit is 65534 and low bit is 31073, the binary form of which is 111111111111110 and 111100101100001, after shifting high 16-bit data to the left, the data becomes 11111111111110011100101100001. The highest data is 1, so the data is negative. Negate the data, the data becomes 11000011010011110, and add 1 to the data, the data becomes 11000011010011111, the decimal form is 99999. Because it is a negative number, so it is -99999.

Bit mode meaning in monitor group:

The parameter meaning in address 923:

MSB	←														LSB
16	15	14	13	12	11	10	9	8	7	6	5	4	3	2	1
—	—	—	—	—	—	—	—	DI8	DI7	DI6	DI5	DI4	DI3	DI2	DI1

The parameter meaning in address 925:

MSB	←														LSB
16	15	14	13	12	11	10	9	8	7	6	5	4	3	2	1
—	—	—	—	—	—	—	—	—	—	—	DO5	DO4	DO3	DO2	DO1

The parameter meaning in address 926, 940

MSB	←														LSB
16	15	14	13	12	11	10	9	8	7	6	5	4	3	2	1
AL-16	AL-15	AL-14	AL-13	AL-11	AL-10	AL-10	AL-09	AL-08	AL-07	AL-06	AL-05	AL-04	AL-03	AL-02	AL-01

Note: “—” means “reserved”, which is used to add new function.

• 5 Example:

(1) In RTU mode, change acc time (Po109) to 5ms in No. 01 servo drive.

Host query:

Address	Function	Register Address Hi	Register Address Lo	Write status Hi	Write status Lo	CRC Lo	CRC Hi
---------	----------	---------------------	---------------------	-----------------	-----------------	--------	--------

01	06	00	6D	00	05	D8	14
----	----	----	----	----	----	----	----

Servo1 write register Po109 5(Unit: ms) CRC check

Slave response:

Address	Function	Register Address Hi	Register Address Lo	Write status Hi	Write status Lo	CRC Lo	CRC Hi
01	06	00	6D	00	05	D8	14

Servo 1 write register Po109 5(Unit: ms) CRC check

(2) In RTU mode, read acc time (Po109) of No. 01 servo drive.

Host query:

Address	Function	First register Hi	First register Lo	Numbers of register Hi	Numbers of register Lo	CRC Lo	CRC Hi
01	03	00	6D	00	01	15	D7

Servo1 read register Po109 one register CRC check

Slave response:

Address	Function	Data numbers	Data Hi	Data Lo	CRC Lo	CRC Hi
01	03	02	00	C8	B9	D2

Servo 1 write register 2 bits 200(Unit: ms) CRC check

10.1.3 Parameter related to communication

Function Code	Function Definition	Setting Range	Setting unit	Mfr's value	Remarks
Po500	Communication address	1~254	—	1	
Po501	Communication mode	0~1	—	0	0: RTU 1: ASCII
Po502	Stop bit	0~1	—	0	0: 1bit 1: 2 bits
Po503	Parity check selection	0~2	—	0	0: No checkout 1: Odd 2: Even
Po504	Baud rate	0~5	bit/s	2	0: 2400 1: 4800 2: 9600 3: 19200 4: 38400 5: 57600



Note: Please set functions code related to communication consonant with the PLC/PC communication parameters, when inverter communicates with PLC/PC.

The command from PC will be written into data memory of servodrive Immediate, it is not good to write the data into the memory continuously.

Permission of Read&Write:

Parameter	Remarks
Po505	0 Permission of Read &Write, the communication data is allowed to be written into data register.
	1 Prohibition of Read&Write, the communication commands are only executed, but they are not allowed to be written into data register. If the servodrive is power off, data will be lost and they need to be written again.

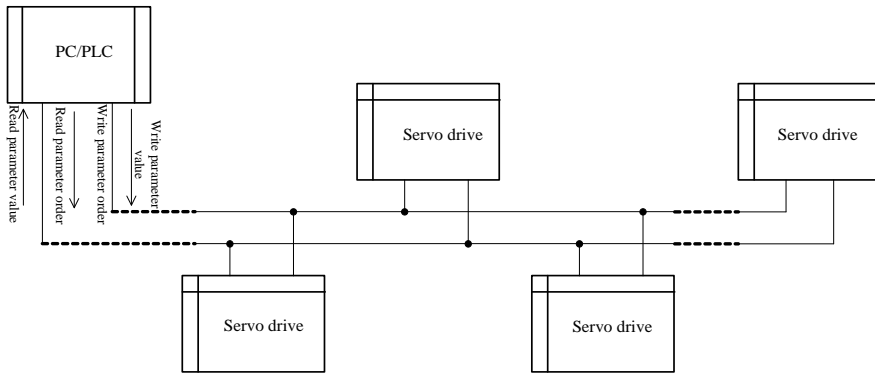

Fig 10-1-1 Connecting diagram of field bus

RS485 Half-duplex communication mode is adopted for servodrive. Daisy chain structure is adopted by 485 Bus-line. Do not use 'spur' lines or a star configuration. Reflect signals which are produced by spur lines or star configuration will interfere in 485 communications.

Please note that for the same time in half-duplex connection, and only one inverter can have communication with PC/PLC. Should two or more than two inverters upload data at the same time, then bus competition will occur, which will not only lead to communication failure, but higher current to certain elements as well.

3 Grounding and Terminal

Terminal resistance of 120Ω will be adopted for terminal of RS485 network, to diminish the reflection of signals. Terminal resistance shall not be used for intermediate network.

No direct grounding shall be allowed for any point of RS485 network. All the equipment in the network shall be well grounded via their own grounding terminal. Please note that grounding wires will not form closed loop in any case.

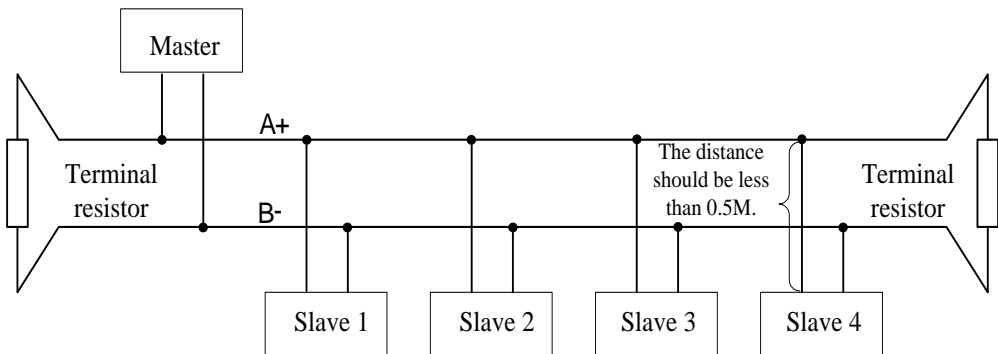

Fig 10-1-2 Connecting Diagram of Terminal Resistance

Please think over the drive capacity of PC/PLC and the distance between PC/PLC and inverter when wiring. Add a repeaters if drive capacity is not enough.

➡ **All wiring connections for installation shall have to be made when the inverter is disconnected from power supply.**

XI Appendix

11.1 Encoder cable selection

11.1.1 Absolute encoder cable

Encoder cable with round plug (applicable for 80 flange and below 80 flange servo motor)

Name	Model	Length	Cable appearance
Encoder cable (for function code D7, D71)	DB9-4BS02-3M-0.2	3M	
	DB9-4BS02-5M-0.2	5M	
	DB9-4BS02-10M-0.2	10M	
	DB9-4GS02-3M-0.2	3M	
	DB9-4GS02-5M-0.2	5M	
	DB9-4GS02-10M-0.2	10M	

Encoder cable with L aviation plug (applicable for 110, 130 and 180 flange servo motor)

Name	Model	Length	Cable appearance
Encoder cable (for function code D7, D71)	DB9-4BS03-3M-0.2	3M	
	DB9-4BS03-5M-0.2	5M	
	DB9-4BS03-10M-0.2	10M	
	DB9-4GS03-3M-0.2	3M	
	DB9-4GS03-5M-0.2	5M	
	DB9-4GS03-10M-0.2	10M	

11.1.2 Incremental encoder cable

Encoder cable with DB plug (applicable for 80 flange and below 80 flange servo motor)

Name	Model	Length	Cable appearance
15-core encoder cable (for D5)	DB15-15GP02-3M-0.2	3M	
	DB15-15GP02-5M-0.2	5M	
	DB15-15GP02-10M-0.2	10M	
8-core encoder cable (for D51)	DB15-8GP02-3M-0.2	3M	
	DB15-8GP02-5M-0.2	5M	
	DB15-8GP02-10M-0.2	10M	
4-core encoder cable (for D52)	DB9-4GS02-3M-0.2	3M	
	DB9-4GS02-5M-0.2	5M	
	DB9-4GS02-10M-0.2	10M	

Encoder cable with L aviation plug (applicable for 110, 130 and 180 flange servo motor)

Name	Model	Length	Cable appearance
15-core encoder cable (for D5)	DB15-15GP01-3M-0.2	3M	
	DB15-15GP01-5M-0.2	5M	
	DB15-15GP01-10M-0.2	10M	
8-core encoder cable (for D51)	DB15-8GP01-3M-0.2	3M	
	DB15-8GP01-5M-0.2	5M	
	DB15-8GP01-10M-0.2	10M	
4-core encoder cable (for D52)	DB9-4GS03-3M-0.2	3M	
	DB9-4GS03-5M-0.2	5M	
	DB9-4GS03-10M-0.2	10M	

Encoder cable with I aviation plug (applicable for servo motor with base No.E,F)

Name	Model	Length	Cable appearance
15-core encoder cable (for D5)	DB15-15GP03-3M-0.2	3M	
	DB15-15GP03-5M-0.2	5M	
	DB15-15GP03-10M-0.2	10M	
8-core encoder cable (for D51)	DB15-8GP03-3M-0.2	3M	
	DB15-8GP03-5M-0.2	5M	
	DB15-8GP03-10M-0.2	10M	

11.1.3 Resolver encoder cable

Encoder cable with Laviationplug (applicable for 180 flange and below 180 flange motor)

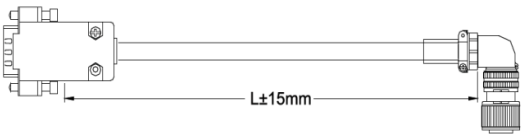
Name	Model	Length	Cable appearance
Encoder cable (for D2)	DB9-8GR01-3M-0.2	3M	
	DB9-8GR01-5M-0.2	5M	
	DB9-8GR01-10M-0.2	10M	

Encoder cable with I aviationplug (applicable for servo motor with base No. E, F)

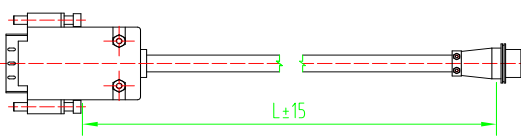
Name	Model	Length	Cable appearance
Encoder cable (for D2)	DB9-8GR02-3M-0.2	3M	
	DB9-8GR02-5M-0.2	5M	
	DB9-8GR02-10M-0.2	10M	

11.2 Control cable

Analog speed and torque mode control cable

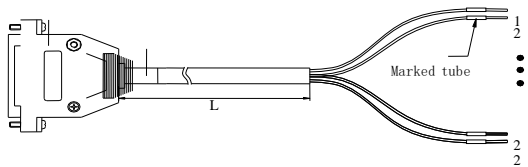
Name	Model	Length	Appearance
Control cable	DB44-15AI-1M-0.2	1M	
	DB44-15AI-2M-0.2	2M	
	DB44-15AI-3M-0.2	3M	

Position mode control cable

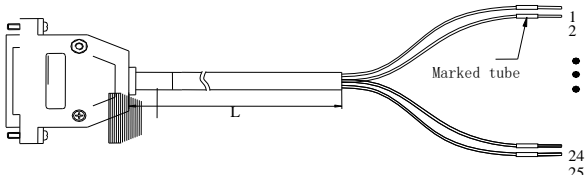
Name	Model	Length	Appearance
Control cable	DB44-15PC-1M-0.2	1M	
	DB44-15PC-2M-0.2	2M	
	DB44-15PC-3M-0.2	3M	

11.3 Power cable

Applicable for 80 flange and below 80 flange servo motor

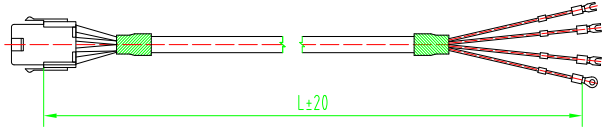
Name	Model	Length	Appearance
Power cable	DB4-4PO-*M-diameter	*M means length	

Applicable for 110, 130 and 180 flange servo motor

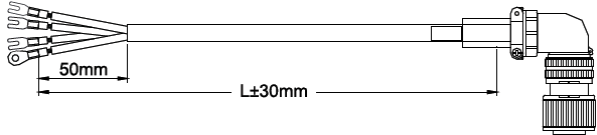
Power cable	HK4A-4PO-*M – diameter	*M means length	
	HK4B-4PO-*M – diameter		

Note: aviation plug is used for servo motor with flange above 110. Servo motor with 180 flange has large current, so the line diameter should be larger, named as “HK4B-4PO-*M-diameter”. Except servo motor with 180 flange, other cables are named as “HK4A-4PO-*M-diameter”. For M1 and M2 structure of 220V servo drive, the name of cable should add –B, for M2 structure of 380V servo drive, the name of cable should add –H.

Applicable for 180 spigot and 250 spigot servo motor

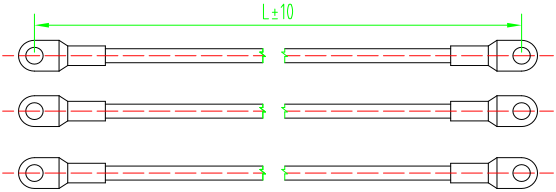
Name	Model	Length	Appearance
Power cable	ZL4-4PO-*M-diameter	*M means length	

Note:

1. ZL4-4PO-XXX is single-strand cable, ground cable is yellow-green 2.5 mm² wire.
2. 180 spigot and 250 spigot servo motors use cable lug, please refer to below table:

Servo Motor	Cable Lug
11KW	6-8
15KW-18.5KW	10-8
22KW-30KW	16-8
37KW	25-8

11.4 Other cable

Communication cable

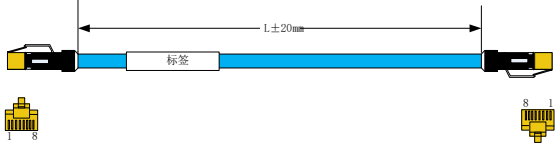
Name	Model	Length	Appearance
Communication cable	1394-2TR- <i>*M</i> -0.3	<i>*M</i> means length	None
Industry Ethernet shield cable	SC-ECT- <i>**M</i> -C	Actual length	

Motor brake cable

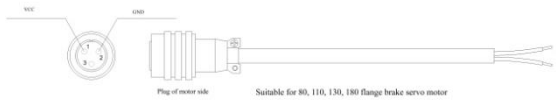
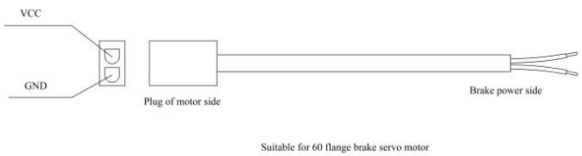
Name	Model	Length	Appearance
Brake cable	HK3-2BR- <i>*M</i> -0.75	Actual length	
Brake cable	DB2-2BR- <i>*M</i> -0.75	Actual length	

11.5 Motor and matched cable

220V servo motor series

Motor model		Servo drive model		Power cable model
FMS series 3000r/min	FMSA-201*32***	FL20-SA201S2M1	FL20-SA201T2M1	DB4-4PO- <i>*M</i> -0.75-B
	FMSA-401*32***	FL20-SA401S2M1	FL20-SA401T2M1	
	FMSA-751*33***	FL20-SA751S2M1	FL20-SA751T2M1	
	FMSA-102*33***	FL20-SA102S2M2	FL20-SA102T2M2	DB4-4PO- <i>*M</i> -1.0-B
	FMSA-122*35***	FL20-SA122S2M2	FL20-SA122T2M2	
	FMSA-152*37***	FL20-SA182S2M2	FL20-SA182T2M2	HK4A-4PO- <i>*M</i> -1.5-B
	FMSA-182*35***			HK4A-4PO- <i>*M</i> -2.5-B
	FMSA-232*37***	—	FL20-SA302T2M3	HK4A-4PO- <i>*M</i> -2.5
FMSA-302*37***	—	FL20-SA452T2M3	HK4A-4PO- <i>*M</i> -4.0	

FL20-SA Series

=====				
FMM series 2000r/min	FMMA-801*35**	FL20-SA102S2M2	FL20-SA102T2M2	HK4A-4PO-*M-0.75-B
	FMMA-851*37**			HK4A-4PO-*M-1.0-B
	FMMA-102*37**	FL20-SA122S2M2	FL20-SA122T2M2	HK4A-4PO-*M-1.0-B
	FMMA-122*35**			
	FMMA-132*37**	FL20-SA182S2M2	FL20-SA182T2M2	HK4A-4PO-*M-1.5-B
	FMMA-152*37**			
	FMMA-202*37**	—	FL20-SA302T2M3	HK4A-4PO-*M-2.5
	FMMA-312*37**	—	FL20-SA452T2M3	HK4B-4PO-*M-4.0
FMMA-352*3A**	—			
=====				
FMM series 1500r/min	FMMA-122*37**	FL20-SA122S2M2	FL20-SA122T2M2	HK4A-4PO-*M-1.0-B
	FMMA-152*37**	FL20-SA182S2M2	FL20-SA182T2M2	HK4A-4PO-*M-1.5-B
	FMMA-232*37**	—	FL20-SA302T2M3	HK4A-4PO-*M-2.5
	FMMA-272*3A**	—		HK4B-4PO-*M-2.5
	FMMA-302*3A**	—	FL20-SA452T2M3	HK4B-4PO-*M-4.0
	FMMA-432*3A**	—	FL20-SA452T2M3	
=====				
FML series 1000r/min	FMLA-102*37**	FL20-SA102S2M2	FL20-SA102T2M2	HK4A-4PO-*M-1.0-B
	FMLA-152*37**	FL20-SA182S2M2	FL20-SA182T2M2	HK4A-4PO-*M-1.5-B
	FMLA-292*3A**	—	FL20-SA302T2M3	HK4B-4PO-*M-2.5
	FMLA-372*3A**	—	FL20-SA452T2M3	HK4B-4PO-*M-4.0

380V servo motor series

Motor model		Servo drive model	Power cable model
FMS series 3000r/min	FMSA-751*63***	FL20-SA102T3M2	DB4-4PO-*M-0.75-H
	FMSA-102*63***		
	FMSA-122*65***	FL20-SA202T3M3	HK4A-4PO-*M-1.0
	FMSA-152*67***		HK4A-4PO-*M-1.0
	FMSA-182*65***		HK4A-4PO-*M-1.5
	FMSA-232*67***	FL20-SA302T3M3	HK4A-4PO-*M-1.5
	FMSA-302*67***	FL20-SA452T3M3	HK4A-4PO-*M-2.5
=====			

FL20-SA Series

MM series 2000r/min	FMMA-801*65**	FL20-SA102T3M2	HK4A-4PO-*M-0.75-H
	FMMA-851*67**		
	FMMA-102*67**		
	FMMA-122*65**	FL20-SA152T3M2	
	FMMA-132*67**		
	FMMA-152*67**	FL20-SA202T3M3	HK4A-4PO-*M-1.0
	FMMA-202*67**		HK4A-4PO-*M-1.5
	FMMA-312*67**	FL20-SA452T3M3	HK4A-4PO-*M-2.5
	FMMA-352*6A**		HK4B-4PO-*M-2.5
	FMMA-452*6A**		HK4B-4PO-*M-2.5
	FMMA-602*6A**	FL20-SA752T3MM4	HK4B-4PO-*M-4.0
	FMMA-802*6A**		
	FMMA-103*6A**	FL20-SA153T3M4	HK4B-4PO-*M-6.0
=====			
FMM series 1500r/min	FMMA-122*67**	FL20-SA202T3M3	HK4A-4PO-*M-1.0
	FMMA-152*67**		
	FMMA-232*67**		HK4A-4PO-*M-1.5
	FMMA-302*67**	FL20-SA302T3M3	HK4A-4PO-*M-2.5
	FMMA-272*6A**	FL20-SA302T3M3	HK4B-4PO-*M-2.5
	FMMA-302*6A**	FL20-SA302T3M3	
	FMMA-432*6A**	FL20-SA452T3M3	
	FMMA-552*6A**	FL20-SA552T3M3	
	FMMA-752*6A**	FL20-SA752T3MM4	HK4B-4PO-*M-4.0
	FM15-0082*6EE*FL	FL20-SA752T3MM4	ZL4-4PO-*M-4.0
	FM15-0100*6EE*FL	FL20-SA113T3MM4	ZL4-4PO-*M-6.0
	FM15-0124*6EE*FL	FL20-SA153T3M4	ZL4-4PO-*M-6.0
	FM15-0160*6EE*FL	FL20-SA183T3M5	ZL4-4PO-*M-10.0
	FM15-0180*6EE*FL		ZL4-4PO-*M-10.0
	FM15-0210*6FE*FL	FL20-SA223T3M5	ZL4-4PO-*M-10.0
	FM15-0240*6EE*FL	FL20-SA303T3M6	ZL4-4PO-*M-16.0
	FM15-0290*6FE*FL	FL20-SA303T3M6	ZL4-4PO-*M-16.0
FM15-0350*6FE*FL	FL20-SA373T3M6	ZL4-4PO-*M-25.0	

=====			
FML series 1000r/min	FMLA-372*6A***	FL20-SA452T3M3	HK4B-4PO-*M-2.5
	FMLA-102*67***	FL20-SA152T3M2	HK4B-4PO-*M-0.75-B
	FMLA-292*6A***	FL20-SA302T3M3	HK4B-4PO-*M-1.5
=====			
FMM series 1700r/min	FM17-0075*6EE*FL	FL20-SA752T3MM4	ZL4-4PO-*M-4.0
	FM17-0092*6EE*FL	FL20-SA113T3MM4	ZL4-4PO-*M-6.0
	FM17-0110*6EE*FL	FL20-SA113T3MM4	ZL4-4PO-*M-6.0
	FM17-0140*6EE*FL	FL20-SA153T3M4	ZL4-4PO-*M-6.0
	FM17-0180*6EE*FL	FL20-SA183T3M5	ZL4-4PO-*M-10.0
	FM17-0210*6FE*FL	FL20-SA223T3M5	ZL4-4PO-*M-10.0
	FM17-0240*6EE*FL	FL20-SA303T3M6	ZL4-4PO-*M-16.0
	FM17-0270*6EE*FL	FL20-SA303T3M6	ZL4-4PO-*M-16.0
FMM series 2000r/min	FM20-0070*6EE*FL	FL20-SA752T3MM4	ZL4-4PO-*M-4.0
	FM20-0100*6EE*FL	FL20-SA113T3MM4	ZL4-4PO-*M-6.0
	FM20-0140*6EE*FL	FL20-SA153T3M4	ZL4-4PO-*M-6.0
	FM20-0180*6EE*FL	FL20-SA183T3M5	ZL4-4PO-*M-10.0
	FM20-0220*6EE*FL	FL20-SA223T3M5	ZL4-4PO-*M-10.0
	FM20-0250*6EE*FL	FL20-SA303T3M6	ZL4-4PO-*M-16.0
	FM20-0280*6EE*FL		ZL4-4PO-*M-16.0
	FM20-0300*6EE*FL	FL20-SA373T3M6	ZL4-4PO-*M-16.0
	FM20-0360*6FE*FL		ZL4-4PO-*M-25.0

XII Appendix 2

12.1 EtherCAT communication card

EtherCAT is a real-time Industrial Ethernet technology with the feature of high performance, low cost, flexible topology and easy operation, which can be used in industrial field high-speed I/O network. It uses standard Ethernet physical layer, transmission medium twisted-pair or optical fiber (100Base-TX or 100Base-FX).

Matching up with EtherCAT bus card, FL20 series servo drive can realize EtherCAT communication function, and also achieve CANopen Drive Profile (CIA402) in the application layer.

Besides of consolidating the control modes of former CANopen DS402, such as profile velocity (pv), profile position (pp), homing (hm) and profile torque (tq), it also supports the control modes of cyclic synchronous

position (CSP), cyclic synchronous velocity (CSV), cyclic synchronous torque (CST). User can select the needed control mode by setting corresponding parameters. It can make the control mode be possible from simple speed control to position control of high-speed and high-precision.

Object		Specification
Communication protocol		Field bus standard: IEC 61158 Type 12, IEC 61800-7 CiA 402 Drive Profile
Application layer	SDO	SDO request, SDO reply
	PDO	Dynamic configuration for 0x1600 and 0x1A00
	CIA402	Profile position mode (pp) Profile velocity mode (pv) Profile torque mode (tq) Homing mode (hm) Cyclic synchronous position mode (csp) Cyclic synchronous velocity mode (csv) Cyclic synchronous torque mode (cst) Interpolation mode (ip) NOP
Physical layer	Transport protocol (media)	IEEE802.3 (100BASE-TX)
	Max distance	100M
	Port	RJ45 * 2 (INT、 OUT)

12.1.1 Installation and Connection

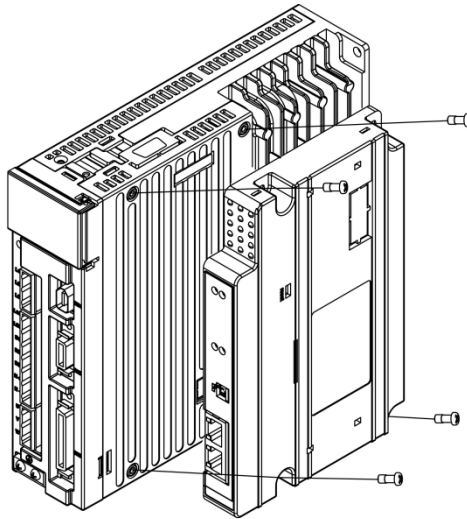

Fig 12.1.1 FL20 series servo drive EtherCAT communication card installation Instruction

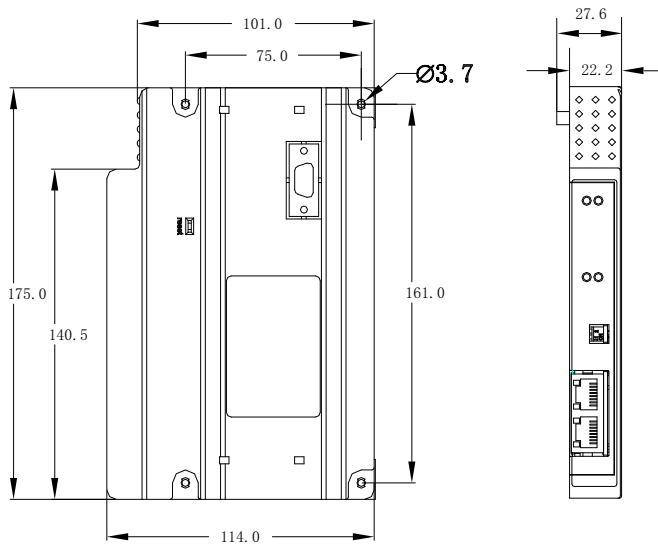

Fig 12.1.2 FL20 series servo drive EtherCAT bus card dimension figure

12.1.2 Hardware Layout

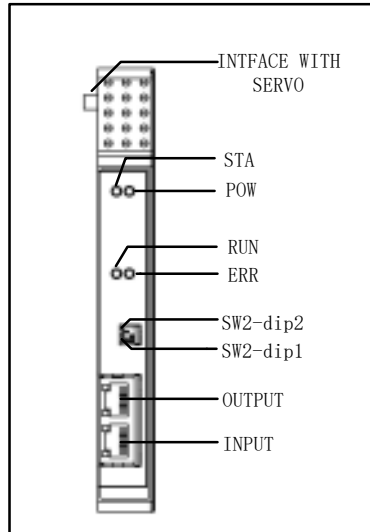

Fig 12.1.3 FL20 series servo EtherCAT bus card instruction

12.1.3 Topology Way

Bus, tree or star: EtherCAT supports almost all topology structures.

Therefore, the bus structure or linear structure can be also used in Ethernet network, and not be limited by the quantity of cascading switch or hub.

Besides of the traditional, Ethernet-based star structure, the most efficient system connection way is peer-to-peer, branch or tree structure. It is no need to add switch because the needed port has already existed in several devices such as I/O module.

User can also select different cables to promote the flexibility of connection: flexible, economic standard Cat 5E Ethernet cable can adopt 100BASE-TX transport signal, the max length of the cable between two devices is 100m.

The combination of different Ethernet wirings (e.g. different optical fiber and copper cable) can be realized by switch or media converter.

Signal variable can be selected separately according to space between each cable. Because the quantity of the connected devices can reach as high as 65535, the capacity of network can be almost unlimited.

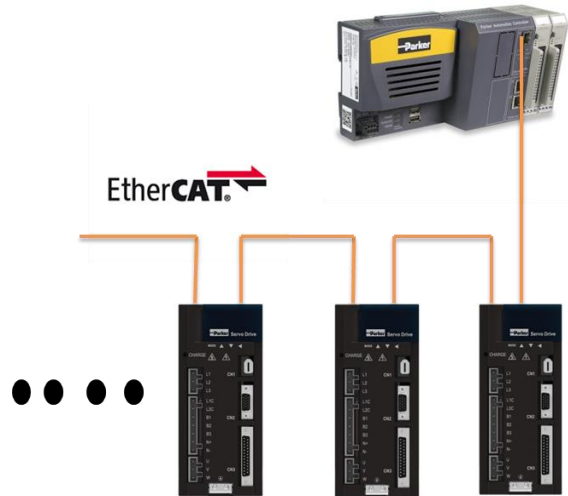

Fig 12.1.4 EtherCAT bus topology connection sketch

12.1.4 LED indicator

Led	Color	Function
POW	Green	Power_on
STA	Green	STATUS
RUN	Green	FieldBus_Run
ERR	Red	FieldBus_Error

12.1.5 Dial switch SW2

SW-dip1	ON	Turn the switch to ON when downloading the program
	OFF	Turn the switch to OFF when running the program.

12.1.6 Servo related parameter setting

Parameter	Name	Setting range	Value
Po001	Control mode selection	Two-parameter	1,21
So-17	Forward forbidden setting	0: disabled 1: enabled	0

So-18	Reverse forbidden setting	0: disabled 1: enabled	0
-------	---------------------------	---------------------------	---

Note: Po004, Po339, Po341 will turn 0 to 1 automatically.

12.2 CANopen communication card

CANopen is a high layer protocol which bases on CAN serial bus system and CAL (CAN application layer). The communication card is used to connect inverter to CAN network.

CANopen bus card overall performance parameter

Object	Content
Link layer protocol	CAN bus
Application layer protocol	CANopen protocol
CAN-ID type	11bit-CAN2.0A
Baud rate	125Kbit/s (default) 125Kbit/s,250Kbit/s,500Kbit/s,1Mbit/s
Max sites	64
CAN frame length	0~8 bytes
Application layer CAN frame type	Data frame
Terminal matched resistance	120 Ω
Sub-protocol	Cia-301 V4.02: CANopen Application layer and communication protocol DSP-402 V2.0: Drive and motion control sub-protocol
Services	NMT: Network Management system SDO: Service data object PDO: Process data object Device monitor: Node protection and beat SYNC: Sync generator and sync receiver, apply to PDO
PDO transport type	Event trigger, sync trigger
PDO quantity	2 RPDO, 2 TPDO
SDO transmission mode	Acceleration SDO
Servo running mode	Profile Position Mode (PP) Profile Speed Mode (PV) Profile Torque Mode(PT)

	Homing Mode (HM) Interpolated Position Mode (IP)
--	---

12.2.1 Installation and Connection

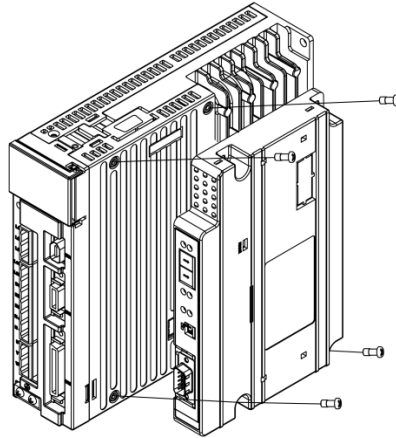

Fig 12.2.1 Servo CANopen communication card installation instruction

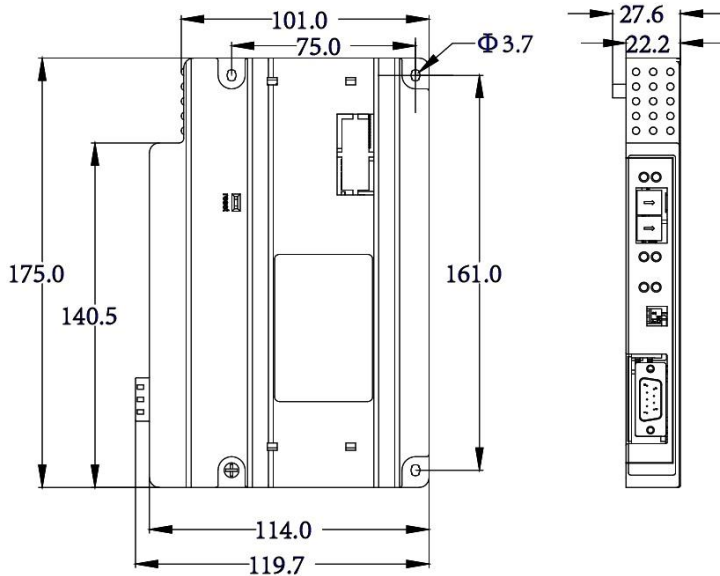

Fig 12.2.2 Servo CANopen bus card dimension

12.2.2 Hardware layout

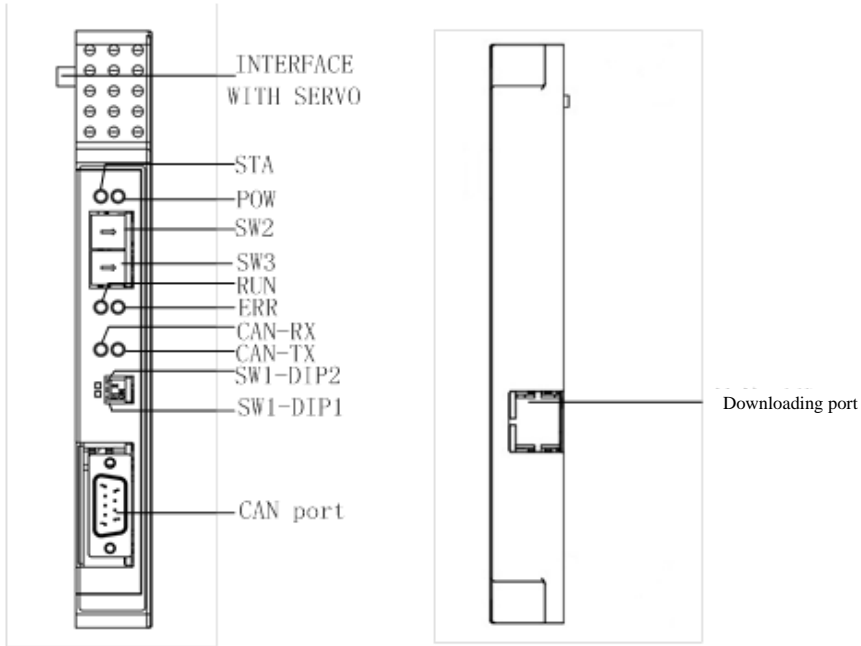

Fig 12.2.3 Servo CANopen bus card sketch map

12.2.3 CAN-bus connection

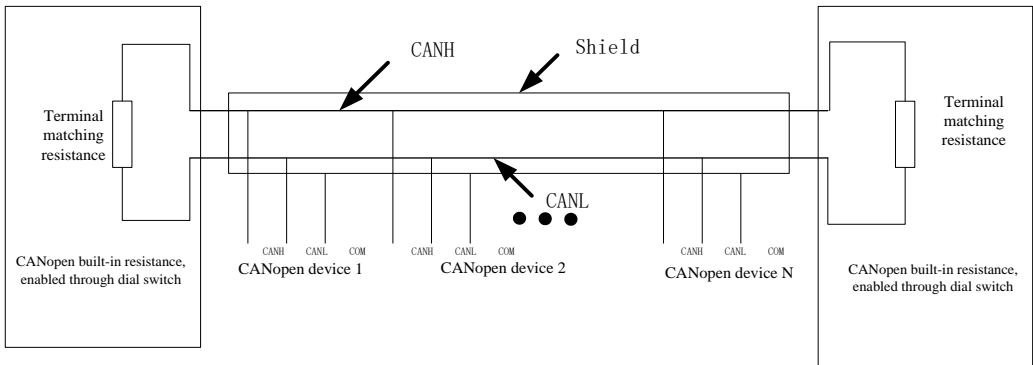
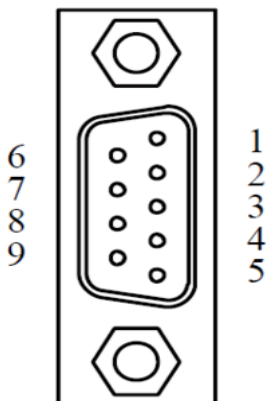

Fig 12.2.4 CAN-bus connection sketch map

12.2.4 CANopen bus interface pins

 <p>Fig 12.2.5 bus interface pins</p>	Pin No.	Pin name	Description
	1	--	N/C
	2	CAN_L	CAN differential signal low-level pin
	3	GND	Ground
	4	Unused	N/C
	5	PE	Cover
	6	GND	Ground
	7	CAN_H	CAN differential signal high-level pin
	8	Unused	N/C
	9	Unused	N/C

12.2.5 Status indicator

Indicator	Color	Function
STA	Green	STATUS
POW	Green	Power_on
RUN	Green	FieldBus_Run
ERR	Red	FieldBus_Error
RX	Green	CAN_RX
TX	Red	CAN_TX

12.2.6 Switch code

[문서에서 멋진 인용문을 가져 오거나 핵심 포인트를 강조하는 공간으로 사용해 보세요. 이 텍스트 상자는 문서 어느 곳에도 끌어다 놓을 수 있습니다.]

Switch code	Position	Instructions
SW1-dip1	ON	Download program
	OFF	Download succeeds.
SW1-dip2	ON	Connect with terminal resistance of CAN network.
	OFF	Disconnect with terminal resistance of CAN network.

The 16-bit switch codes of SW3 and SW2 are used to set the baud rate and communication address of CAN bus.

Table 12.2.2 CANopen bus card address and baud rate setting

Baud rate Address	125Kbit/s	250Kit/s	500Kbit/s	1Mbit/s
	1+SW2	SW3 = 0	SW3 = 1	SW3 = 2
1+16+SW2	SW3 = 4	SW3 = 5	SW3 = 6	SW3 = 7
1+31+SW2	SW3 = 8	SW3 = 9	SW3 = A	SW3 = B
1+47+SW2	SW3 = C	SW3 = D	SW3 = E	SW3 = F

12.2.7 Servo related parameter setting

Parameter	Name	Setting range	Value
Po001	Control mode selection	Two-parameter	1,21
So-17	Forward forbidden setting	0: disabled 1: enabled	0
So-18	Reverse forbidden setting	0: disabled 1: enabled	0

Note: Po004, Po339, Po341 will turn 0 to 1 automatically.

N2018051801

Parker Asia Pacific

China

Sales Office

Shanghai office, 86-21-28995000
Parker Hannifin Motion&Control Co. Ltd.
280 Yunqiao Road, Jin Qiao Export Processing Zone,
Shanghai 201206, China

Sales Office

Guangzhou Office, 86-20 32121688
Parker Hannifin Motion&Control Co.Ltd.
Room 202, Building F, Guangdong Soft Science Park,
No 11, Caipin Road, Guangzhou Science City,
Luo Gang District, Guangzhou 510663, China

Sales Office

Beijing office, 86-10-6561-0520
Parker Hannifin Motion&Control Co.Ltd.
Suite 8B01, 8th Floor, Hanwei Plaza,7 Guanghua Road,
Chaoyang District, Beijing 100004, P.R.China

Automation Division

WUXI plant, 86-510-8116-7000
Parker Hannifin Motion and Control (Wuxi) Company Ltd.
No.200, Furong Zhong Si Lu, Xishan Economic Development Zone,
Wuxi 214101, Jiangsu, China

Japan

Sales Office

Asahi Plant, 81-479-64-2282
kpl_sales@parker.com
Kuroda Pneumatics LTD
10243 Kamakazu, Asahi-shi, Chiba 289-2505 Japan

Automation Division

Asahi Plant, 81-479-64-2282
Kuroda Pneumatics LTD
10243 Kamakazu, Asahi-shi, Chiba 289-2505 Japan

Korea

Sales Office

Seoul Office, 822-559-0400
11F, U-Space1 B, 660, Daewangpangyo-ro, Bundang-gu,
Seongnam-si, Gyeonggi-do, 13494, Korea

Automation Division

Jangan Plant, 82 31-359-0700
Parker Korea Ltd.
23, Jangangongdan 1-gil, Jangan-myeon,
Hwaseong-si, Gyeonggi-do, 18579, Korea

India

Sales Office

PHI Chennai Sales office, 91-44-43910799
Parker Hannifin India Private. Limited,
Plot no. P41/2, Eight Avenue, Domestic Tariff Area,
Mahindra world city, Chengalpattu, Kanchipuram District,
Pin : 603002, Tamil Nadu, India

Automation Division

PHI Chennai MWC Plant, 91-44-43910703
Parker Hannifin India Private. Limited,
Plot no. P41/2, Eight Avenue, Domestic Tariff Area,
Mahindra world city, Chengalpattu,
Kanchipuram District,
Pin : 603002, Tamil Nadu, India

Taiwan

Sales Office

Taipei Office, 886-2-2298897
Parker Hannifin Taiwan Co., Ltd.
8F., No.22 Wuquan 7th Road., Wugu Dist., New Taipei City, 248,
Taiwan (R.O.C)

Thailand

Sales Office

Bangkok Office, (66) 2 186 7000
Parker Hannifin (Thailand) Co., Ltd.
1265 Rama 9 Road, Suanluang Bangkok 10250 Thailand

Singapore

Sales Office

Office: +65 6887 6300
Parker Hannifin Singapore Pte Ltd.
11th Fourth Chin Bee Road Singapore 619702

Malaysia

Sales Office

Selangor Office, +603 7849 0800
Parker Hannifin Industrial (M) Sdn Bhd
No.11 Persiaran Pasak Bumi
Seksyen U8, Bukit Jelutong Industrial Park
40150 Shah Alam, Selangor, Malaysia

Indonesia

Sales Office

Office: +62-21-7588-1906
PT. Parker Hannifin Indonesia
Wisma Contromatic, Jalan Kapten Soebijanto
Djodjohadikusumo, Kav. Sunburst Block CBD II No.15
BSD (Bumi Serpong Damai), Tangerang 15322,
Indonesia

Vietnam

Sales Office

Office: (84) 8 3999 1600
Parker Hannifin Vietnam Co., Ltd.
4th Floor, VRG office building,
177 Hai Ba Trung, Ward 6, District 3
Ho Chi Minh City,
Vietnam

Australia

Sales Office

Office: +61-2-9634-7777
Parker Hannifin (Australia) Automation Department
9 Carrington Rd Castle Hill, NSW, 2154 Australia

New Zealand

Sales Office

Office: +64 9 574 1744
Parker Hannifin (NZ) Ltd.
5 Bowden Road, Mt Wellington 1060, Auckland, New Zealand

