

C081 Variable Displacement Axial Piston Pump Service Information

HY28-2687-02/C/US January 2017



ENGINEERING YOUR SUCCESS.

Contents

Installation Information	1
Unit Identification	3
Model Codes	4
Pump Porting	8
Control Kits	10
Exploded View	11
Bill of Material	13
Kits	14
Seal Kit.....	14
Housing.....	15
Housing Cover Kit.....	15
Shaft Assembly Kit.....	15
Shaft Retainer Kit.....	16
Swashplate Kit.....	16
Rotating Group.....	16
Valve Plate Kit.....	17
House Bearing.....	17
Bushing Kit.....	17
Throttle Valve Kit.....	17
Servo Piston Kit.....	18
Servo Cap Kit.....	18
Charge Pump Kits.....	19
Through Drive Kits.....	19
Override Kits/Charge Filter Options.....	20
Automotive Control Valve and Accessories.....	22
Pressure Override Cartridge.....	22
Charge Pressure Relief.....	22
Relief Assembly.....	22
Relief Only.....	22
Disassembly and Assembly	23
Disassembly Procedure.....	23
Assembly Procedure.....	24
Tools	35
Setting Procedure	36
Control Setting Values	46
Troubleshooting Information	47
Notes	48
Offer of Sale	50
Revisions	51

⚠ WARNING - USER RESPONSIBILITY

FAILURE OR IMPROPER SELECTION OR IMPROPER USE OF THE PRODUCTS DESCRIBED HEREIN OR RELATED ITEMS CAN CAUSE DEATH, PERSONAL INJURY AND PROPERTY DAMAGE.

This document and other information from Parker-Hannifin Corporation, its subsidiaries and authorized distributors provide product or system options for further investigation by users having technical expertise. The user, through its own analysis and testing, is solely responsible for making the final selection of the system and components and assuring that all performance, endurance, maintenance, safety and warning requirements of the application are met. The user must analyze all aspects of the application, follow applicable industry standards, and follow the information concerning the product in the current product catalog and in any other materials provided from Parker or its subsidiaries or authorized distributors. To the extent that Parker or its subsidiaries or authorized distributors provide component or system options based upon data or specifications provided by the user, the user is responsible for determining that such data and specifications are suitable and sufficient for all applications and reasonably foreseeable uses of the components or systems.

Offer of Sale

The items described in this document are hereby offered for sale by Parker-Hannifin Corporation, its subsidiaries or its authorized distributor. This offer and its acceptance are governed by the provisions stated in the detailed "Offer of Sale" elsewhere in this document.



Installation Information

Guidelines

Pump case should be filled prior to start up and plumbed to ensure it remains filled with fluid under all conditions. Pump case pressure should not exceed 4 bar (58 PSI) continuous pressure, 6 bar (87 PSI) on cold start up.

Care should be taken to ensure line velocities are not above standard design specifications as noted in *Table 1*. Raised line velocities will cause an increase in pressure loss in the hoses and cause premature failure under certain conditions. Pressure in the suction line of the pump should never be below .8 bar (11.6 PSI) absolute. Maximum suction pressure is 4 bar (58 psi) continuous and 6 bar (87 PSI) on cold startup.

Long line lengths and sharp turns in the fluid conveyance will add additional pressure loss or restriction to the system. It is recommended to keep the line lengths as short as possible and to avoid as many fluid direction changes in the system as possible.

Function	Fluid Velocity m/sec (Ft/sec)
Suction	0.6-1.2 (2-4)
Case Drain	1.5-3 (5-10)
Pressure	3-6 (10-20)

Orientation

The C series pump can be installed in many different orientations, see *Figure 1* for examples. If you want to mount the unit in an orientation not shown, please contact technical support.

It is suggested that the pump be mounted so that it is level or below minimum fluid level in the hydraulic reservoir. The pump can be mounted above fluid level but extra attention must be paid to ensure that the case remains filled at all times and proper suction pressure is maintained.

Regardless of installation orientation, the highest case drain port (L1, L2 or L3) should always be used and should return below fluid level. See *Figure 2* for drain port suggestions and suggested air bleed port.

Air bleed port should only be used while filling the case of the unit to ensure the unit is completely filled with fluid. Once the unit is filled, the air bleed port should be closed via a port plug or shut-off valve.

Fluid

Parker recommends using a fluid with a petroleum base that contains agents which provide oxidation inhibition and antirust, antifoam and de-aerating properties as described in Parker standard HF-1. Where antiwear additive fluids are specified, see Parker standard HF-0.

Use fluids with a minimum viscosity index of 90. Higher viscosity index extends the range of operating temperatures but may reduce the service life of the fluid.

It is recommended that the reservoir, hydraulic fluid and fluid conveyance items be cleaned prior to use. Filtration of the fluid is recommended before and during use. Maximum fluid contamination level is 20/18/15 per ISO 4406:1999. Better cleanliness levels will increase the life of the system.

Figure 1: Optional Mounting Orientations

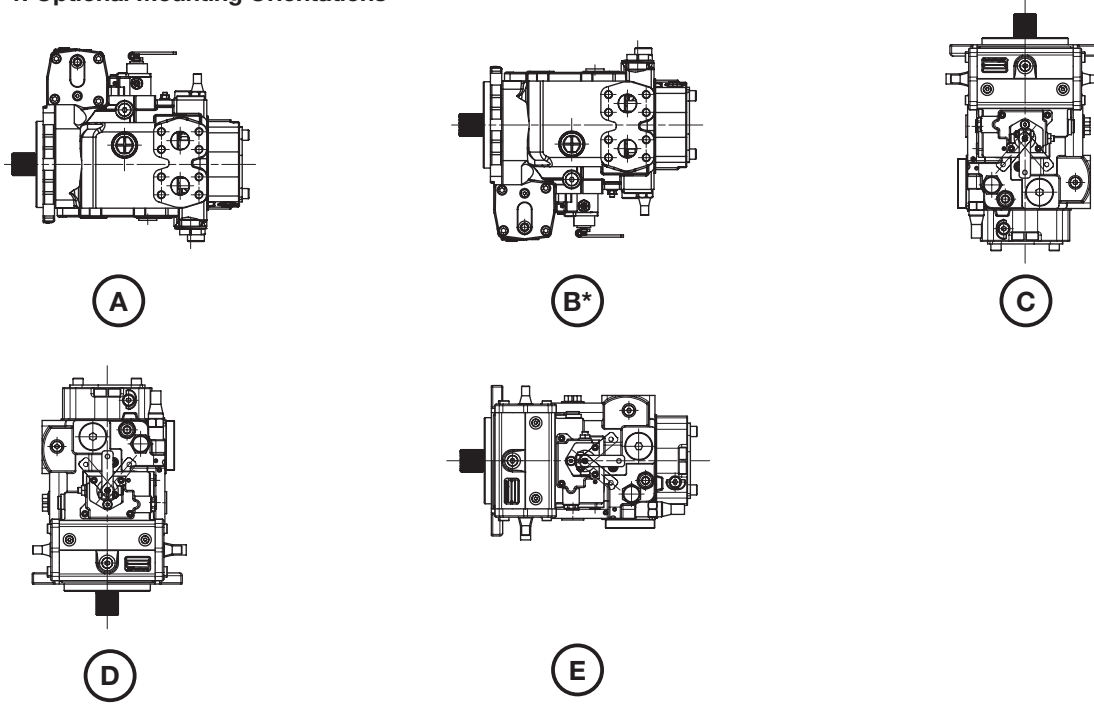

**Contamination can cause issues when mounting in this orientation. Ensure system is clean when this orientation is used.*

Figure 2: Case Drain And Air Bleed Recommendations

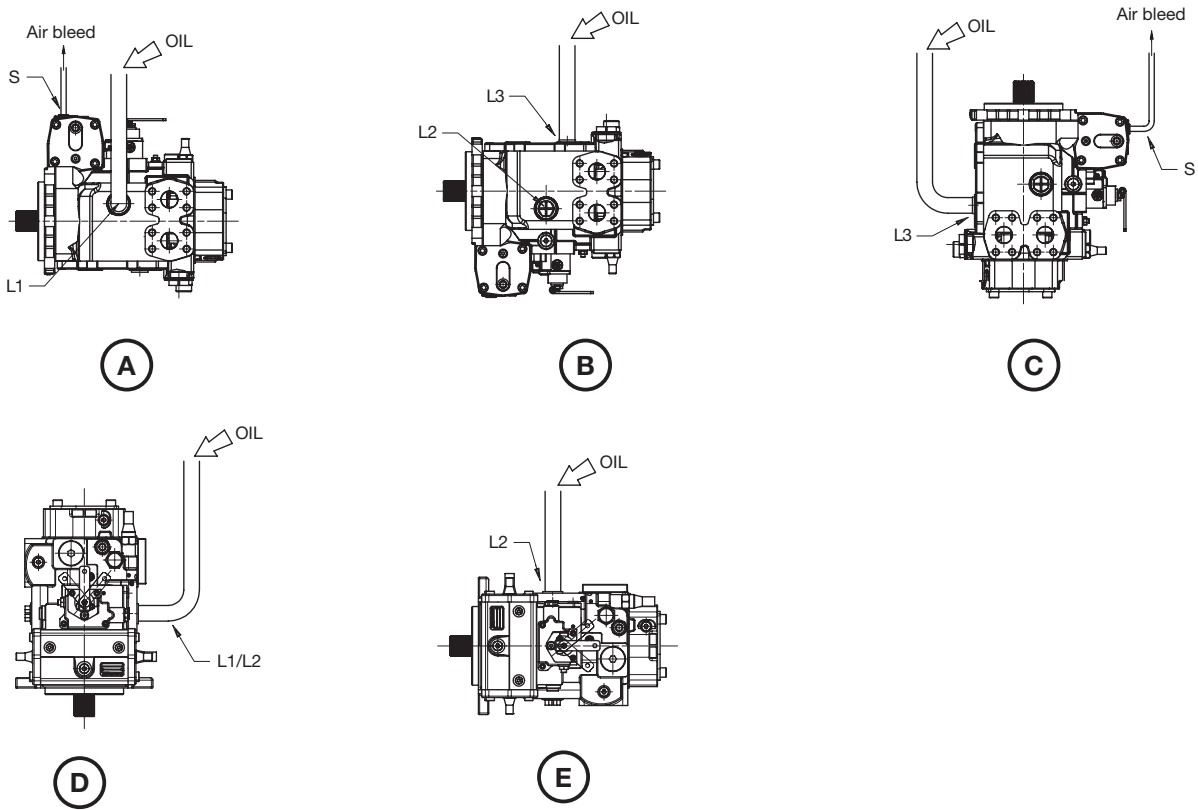

Customer must verify adequate cooling flow through pump case in their application.

Unit Identification

All Parker Hydraulic Pump and Power Systems Division products are supplied with an identification plate. Units can be properly identified only if all information is supplied.

DO NOT REMOVE, ALTER OR DAMAGE THE DATA PLATE.

C Series Identification Tag

The Identification tag on the C series pumps will have the following layout:

The top line of the model code will contain the model code for the unit.

The second line of the tag will also have model code information. It is also important to note the final digit of the model code is truncated as it would not leave enough space for the code number, which will also be on the second line of the identification tag. The code number is generated by Parker Hydraulic Pump and Power Systems Division and will be specific to a single model code combination.

The third line of the model code will contain the unit serial number. Serial number provides month and year of production as well as the batch number.

Serial number detail:

The first two digits of the serial number provide the year and month of production. The letter in position 1 indicated the year of production while the letter in position 2 indicates the month of production. See the tables for details on positions 1 and 2. The remaining digits identify the batch number the unit was produced in.

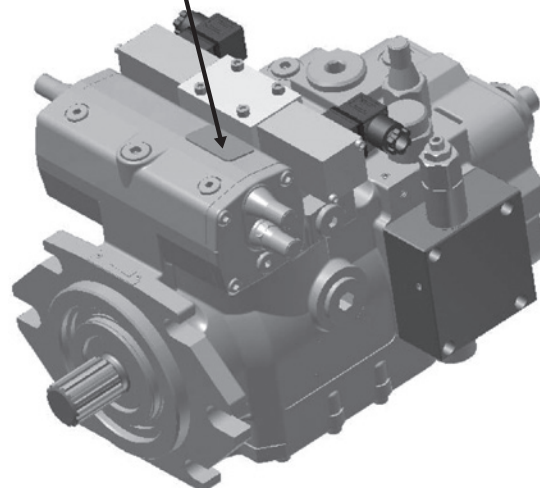
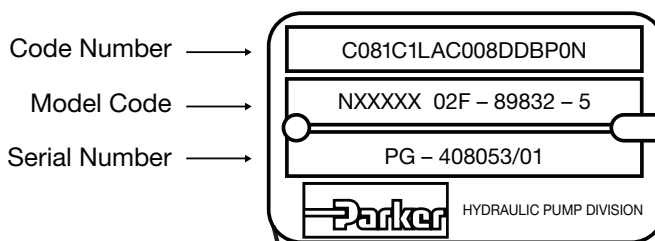

Position 1 Letter	Year
A	2001
B	2002
C	2003
D	2004
E	2005
F	2006
G	2007
H	2008
J	2009
K	2010
L	2011
M	2012
N	2013
P	2014
Q	2015
R	2016
S	2017
T	2018
U	2019
V	2020
W	2021
X	2022
Y	2023
Z	2024

Position 2 Letter	Month
A	January
B	February
C	March
D	April
E	May
F	June
G	July
H	August
J	September
K	October
L	November
M	December

Model Codes

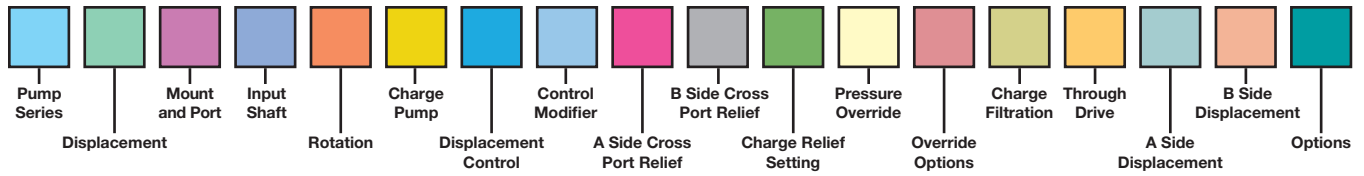

Pump Series	
C	C Series closed circuit pump

Displacement	
055	055 cc/rev (3.35 CIR)
081	081 cc/rev (4.94 CIR)
136	136 cc/rev (8.3 CIR)

Mount and Port Options	
C	SAE C 2/4 bolt mount with SAE ports (55 and 81 only)
D	SAE D 2/4 bolt mount with SAE ports (55 and 81 only)
G	SAE C 2/4 bolt mount with ISO ports (136 only)
H	SAE D 2/4 bolt mount with ISO ports (136 only)

Rotation	
R	CW (clockwise)
L	CCW (counter clockwise)
As viewed looking at the shaft	

Charge Pump	055	081	136
A	18 cc/rev (1.1 CIR)	#	#
B	23.1 cc/rev (1.41 CIR)	—	X
C	27.3 cc/rev (1.65 CIR)	—	X
D	11 cc/rev (0.67 CIR)	X	—
E	14 cc/rev (0.85 CIR)	X	—
X	No charge pump	X	X

= Standard option
X = Available
— = Not available

Pump Control	
A	Manual lever
C	Hydraulic proportional control with internal feedback
D	Hydraulic proportional control without internal feedback
E	Electric non proportional
F	Electric proportional with internal feedback
G	Electric proportional without internal feedback
H	Electric proportional with internal feedback and hydraulic override
J	Automotive control electrical
K	Automotive control hydraulic

Input Shaft	055	081	136
1	SAE C 14T 12/24 DP 1 1/4" OD ANSI B92.1a-1976	#	#
2	21T 16/32 DP 1 3/8" OD ANSI B92.1a-1976	X	X
3	SAE D-E 13T 8/16 DP 1 3/4" OD ANSI B92.1a-1976	—	—
4	SAE F 15T 8/16 DP 2" OD ANSI B92.1a-1976	—	—
5	23T 16/32 DP 1 1/2" OD ANSI B92.1a-1976	—	—
6	27T 16/32 DP 1 3/4" OD ANSI B92.1a-1976	—	—
7	W40x2x30x18 DIN 5480	—	—
8	W45x2x30x21 DIN 5480	—	—

= Standard option
X = Available
— = Not available



Model Codes

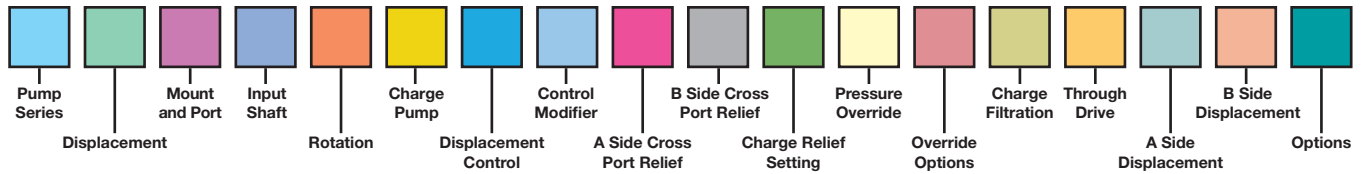

Pump Control										Control Modifier			
A	C	D	E	F	G	H	J	K		Pump control selection determines what modifier is used			
#	-	A	-	-	-	-	-	-	<->	0	0	0	No control orifices
-	-	X	-	-	-	-	-	-	<->	0	0	5	0.5 mm (.019 in) Control orifice
-	X	X	-	-	-	-	-	-	<->	0	0	6	0.6 mm (.024 in) Control orifice
-	X	X	-	-	-	-	-	-	<->	0	0	7	0.7 mm (.027 in) Control orifice
-	#	X	-	-	-	-	-	-	<->	0	0	8	0.8 mm (.031 in) Control orifice
-	X	#	-	-	-	-	-	-	<->	0	0	9	0.9 mm (.035 in) Control orifice
-	X	X	-	-	-	-	-	-	<->	0	1	2	1.2 mm (.047 in) Control orifice
-	-	-	-	X	-	-	-	-	<->	2	0	0	12 VDC, No control orifice
-	-	-	-	X	-	-	-	-	<->	2	0	6	12 VDC, 0.6 mm (.024 in) Control orifice
-	-	-	-	X	-	-	-	-	<->	2	0	7	12 VDC, 0.7 mm (.027 in) Control orifice
-	-	-	-	#	X	X	-	-	<->	2	0	8	12 VDC, 0.8 mm (.031 in) Control orifice
-	-	-	X	X	-	-	-	-	<->	2	1	2	12 VDC, 1.2 mm (.047 in) Control orifice
-	-	-	-	X	-	-	-	-	<->	2	2	0	12 VDC, 2.0 mm (.079 in) Control orifice
-	-	-	-	X	-	-	-	-	<->	4	0	0	24 VDC, No control orifice
-	-	-	-	X	-	-	-	-	<->	4	0	6	24 VDC, 0.6 mm (.024 in) Control orifice
-	-	-	-	X	-	-	-	-	<->	4	0	7	24 VDC, 0.7 mm (.027 in) Control orifice
-	-	-	-	#	#	#	-	-	<->	4	0	8	24 VDC, 0.8 mm (.031 in) Control orifice
-	-	-	X	X	-	-	-	-	<->	4	1	2	24 VDC, 1.2 mm (.047 in) Control orifice
-	-	-	-	X	-	-	-	-	<->	4	2	0	24 VDC, 2.0 mm (.079 in) Control orifice
-	-	-	-	-	-	-	X	-	<->	D			No inching valve, 12 VDC coils, J control only
-	-	-	-	-	-	-	X	-	<->	E			Hydraulic inching valve, 12 VDC coils, J control only
-	-	-	-	-	-	-	X	-	<->	F			No inching valve, 24 VDC coils, J control only
-	-	-	-	-	-	-	X	-	<->	G			Hydraulic inching valve, 24 VDC coils, J control only
-	-	-	-	-	-	-	-	X	<->	H			Hydraulic inching valve, K control only
-	-	-	-	-	-	-	-	X	<->	X			No inching valve, K control only
-	-	-	-	-	-	-	X	X	<->	2			1.2 mm (.047 in) Control orifice
-	-	-	-	-	-	-	X	X	<->	5			1.5 mm (.059 in) Control orifice
-	-	-	-	-	-	-	X	X	<->	P			Prepared for flushing valve
-	-	-	-	-	-	-	X	X	<->	1			Flushing valve installed with 1.5 mm orifice
-	-	-	-	-	-	-	X	X	<->	2			Flushing valve installed with 2.0 mm orifice
-	-	-	-	-	-	-	X	X	<->	3			Flushing valve installed with 2.5 mm orifice
# = Standard option X = Available - = Not available A = Without pressure override only										Example modifier with J/K control			
										G	5	P	Hydraulic inching valve, 24VDC coils with a 1.5 mm control orifice and prepared for flushing
										When ordering J/K control specify starting input RPM, input RPM at rated torque and rated input torque (NM)			

A Side Cross Port Relief	
A	250 Bar (3625 PSI)
B	350 Bar (5075 PSI)
C	420 Bar (6090 PSI)
D	450 Bar (6525 PSI)

B Side Cross Port Relief	
A	250 Bar (3625 PSI)
B	350 Bar (5075 PSI)
C	420 Bar (6090 PSI)
D	450 Bar (6525 PSI)

Charge Relief Setting	055	081	136	
A	20 Bar (290 PSI)	X	X	-
B	22 Bar (319 PSI)	#	#	#
C	25 Bar (362 PSI)	X	X	X

= Standard option
 X = Available
 - = Not available



Model Codes

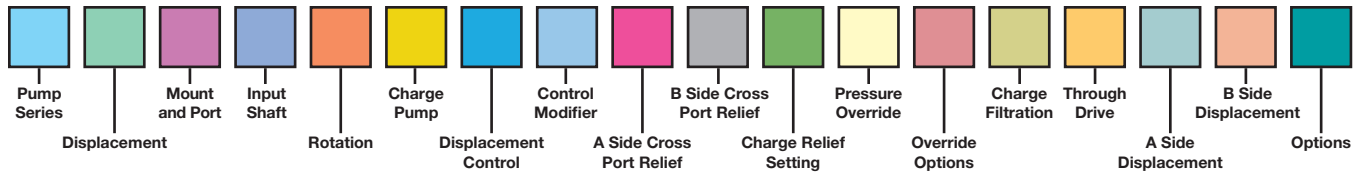

Pressure Override	
X	No pressure override
P	Hydraulic internal pressure override
E	Electrical override
C	Electrical override and hydraulic internal pressure override
<i>Override not available on J/K control. Pressure override should be set 20-30 bar below cross port relief settings.</i>	

Pressure Override					Override Options		
X	P	E	C		Pressure override selection determines override option		
X	—	—	—	<=>	X	X	No pressure override
—	X	—	—	<=>	0	A	Locked
—	X	—	—	<=>	0	B	100 Bar (1450 PSI)
—	X	—	—	<=>	0	C	150 Bar (2175 PSI)
—	X	—	—	<=>	0	D	200 Bar (2900 PSI)
—	X	—	—	<=>	0	E	250 Bar (3625 PSI)
—	X	—	—	<=>	0	F	280 Bar (4060 PSI)
—	X	—	—	<=>	0	G	300 Bar (4350 PSI)
—	X	—	—	<=>	0	H	320 Bar (4712 PSI)
—	X	—	—	<=>	0	J	330 Bar (4785 PSI)
—	X	—	—	<=>	0	K	350 Bar (5075 PSI)
—	X	—	—	<=>	0	M	380 Bar (5510 PSI)
—	X	—	—	<=>	0	N	400 Bar (5800 PSI)
—	—	X	—	<=>	1	2	12 VDC coil
—	—	X	—	<=>	2	4	24 VDC coil
—	—	—	X	<=>	2	A	12VDC coil locked override
—	—	—	X	<=>	2	B	12VDC coil, 100 Bar (1450 PSI) override
—	—	—	X	<=>	2	C	12VDC coil, 150 Bar (2175 PSI) override
—	—	—	X	<=>	2	D	12VDC coil, 200 Bar (2900 PSI) override
—	—	—	X	<=>	2	E	12VDC coil, 250 Bar (3625 PSI) override
—	—	—	X	<=>	2	G	12VDC coil, 300 Bar (4350 PSI) override
—	—	—	X	<=>	2	K	12VDC coil, 350 Bar (5075 PSI) override
—	—	—	X	<=>	2	M	12VDC coil, 380 Bar (5510 PSI) override
—	—	—	X	<=>	2	N	12VDC coil, 400 Bar (5800 PSI) override
—	—	—	X	<=>	4	A	24 VDC coil locked override
—	—	—	X	<=>	4	B	24 VDC coil, 100 Bar (1450 PSI) override
—	—	—	X	<=>	4	C	24 VDC coil, 150 Bar (2175 PSI) override
—	—	—	X	<=>	4	D	24 VDC coil, 200 Bar (2900 PSI) override
—	—	—	X	<=>	4	E	24 VDC coil, 250 Bar (3625 PSI) override
—	—	—	X	<=>	4	G	24 VDC coil, 300 Bar (4350 PSI) override
—	—	—	X	<=>	4	K	24 VDC coil, 350 Bar (5075 PSI) override
—	—	—	X	<=>	4	M	24 VDC coil, 380 Bar (5510 PSI) override
—	—	—	X	<=>	4	N	24 VDC coil, 400 Bar (5800 PSI) override

X = Available
— = Not available



Model Codes

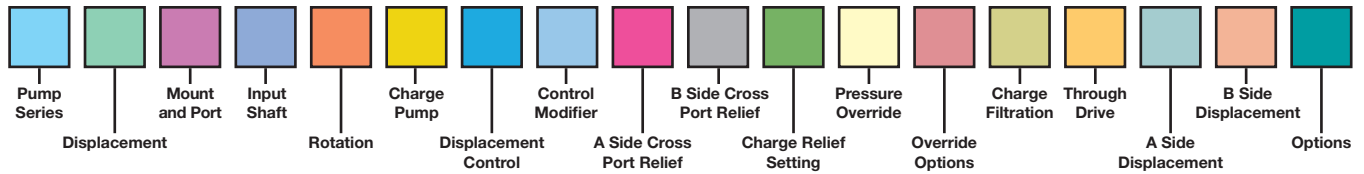

Charge Filtration		055	081	136
X	No charge filter	#	#	#
N	Charge filter with 8 Bar (116 PSI) mechanical bypass indicator	X	X	X
G	Charge filter with 8 Bar (116 PSI) electrical bypass indicator	X	X	X
R	Prepared for remote charge pressure filtration	X	X	X

= Standard option
X = Available
- = Not available

A Side Displacement	
00-99	Set displacement of A side between 0-99%
XX	XX = 100% displacement

B Side Displacement	
00-99	Set displacement of B side between 0-99%
XX	XX = 100% displacement

Options		055	081	136
X	No paint, no bypass valve	#	#	#
Y	No paint with bypass valve	X	X	-
P	Paint black, no bypass valve	X	X	X
D	Paint black with bypass valve	X	X	-
M	Special modification contact technical support			

= Standard option
X = Available all displacements
- = Not available

Through Drive		055	081	136
X	No through drive	#	#	#
A	SAE A mount, 9T spline shaft	X	X	X
B	SAE B mount, 13T spline shaft	X	X	X
G	SAE B mount, 15T spline shaft	X	X	X
C	SAE C mount, 14T spline shaft	X	X	X
H	SAE C mount, 17T spline shaft	X	X	X
D	SAE D mount, 13T spline shaft	X	X	X

= Standard option
X = Available
- = Not available

Example Model Code

C081C1RAF208BBBP0HRAXXXP

- C081** = 81cc frame
- C** = SAE C 2/4 bolt mount with SAE ports
- 1** = SAE C 14T 12/24 DP 1-1/4" OD ANSI B92.1A-1976
- R** = CW rotation (looking at the shaft)
- A** = 81cc frame 18cc/rev (1.1 CIR) charge pump
- F** = Electric proportional with internal feedback displacement control
- 208** = 12 VDC, 0.8mm (.031 in) control orifice
- B** = A side cross port relief set to 350 bar (5075 PSI)
- B** = B side cross port relief set to 350 bar (5075 PSI)
- B** = Charge relief set to 22 bar (319 PSI)
- P** = Hydraulic internal pressure override
- 0H** = Pressure override set to 320 bar (4712 PSI)
- R** = Prepared for remote charge pressure filtration
- A** = SAE A mount through drive with 9T spline shaft coupling
- XX** = A side displacement set to 100%
- XX** = B side displacement set to 100%
- P** = Paint black, no bypass valve

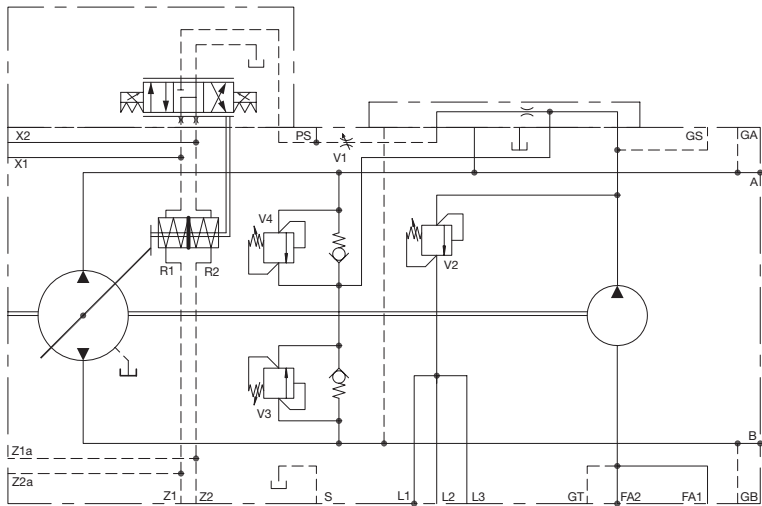
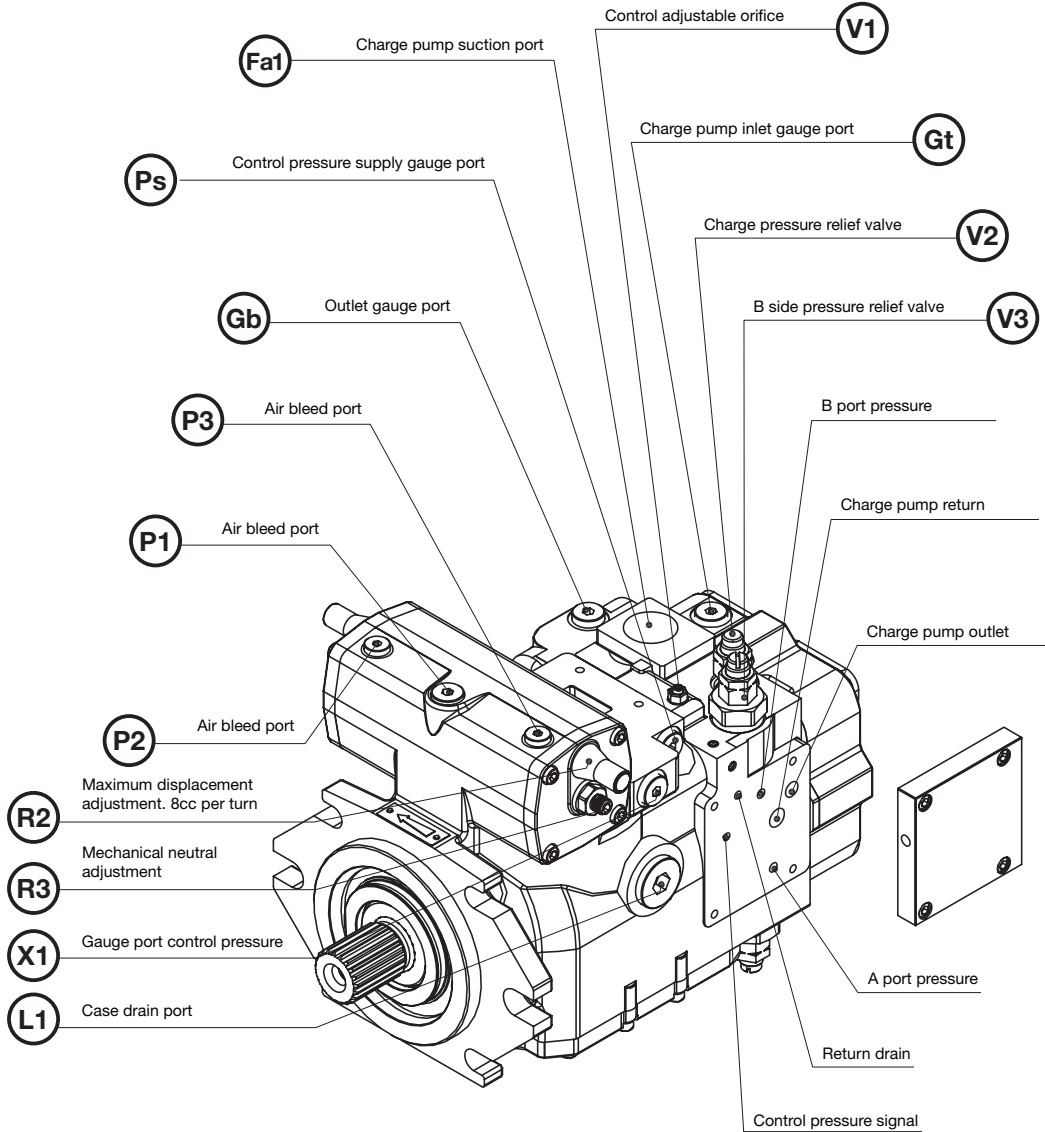

Schematic shown is a C081 with "F" control. No pressure override option.

C081 Port Chart		
Port	Mount C	Mount G
A	1" SAE Code 62	1" SAE Code 62
B	1" SAE Code 62	1" SAE Code 62
L1	-12 SAE ORB	3/4" G
L2	-12 SAE ORB	3/4" G
L3	-12 SAE ORB	3/4" G
FA1	-16 SAE ORB	1" G
FA2	-16 SAE ORB	1" G
GA	-4 SAE ORB	1/4" G
GB	-4 SAE ORB	1/4" G
GS	-4 SAE ORB	1/4" G
PS	-4 SAE ORB	1/4" G
P1	-4 SAE ORB	1/4" G
P2	-4 SAE ORB	1/8" G
P3	-4 SAE ORB	1/8" G
X1	-4 SAE ORB	1/4" G
X2	-4 SAE ORB	1/4" G
GT	-4 SAE ORB	1/4" G



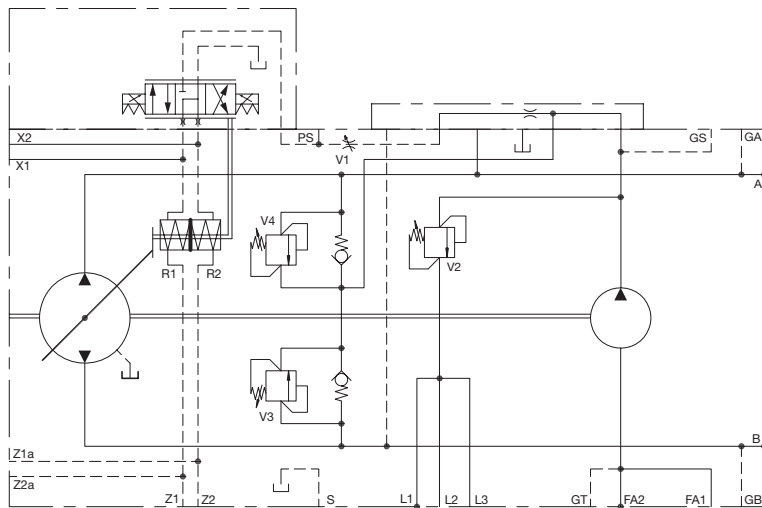
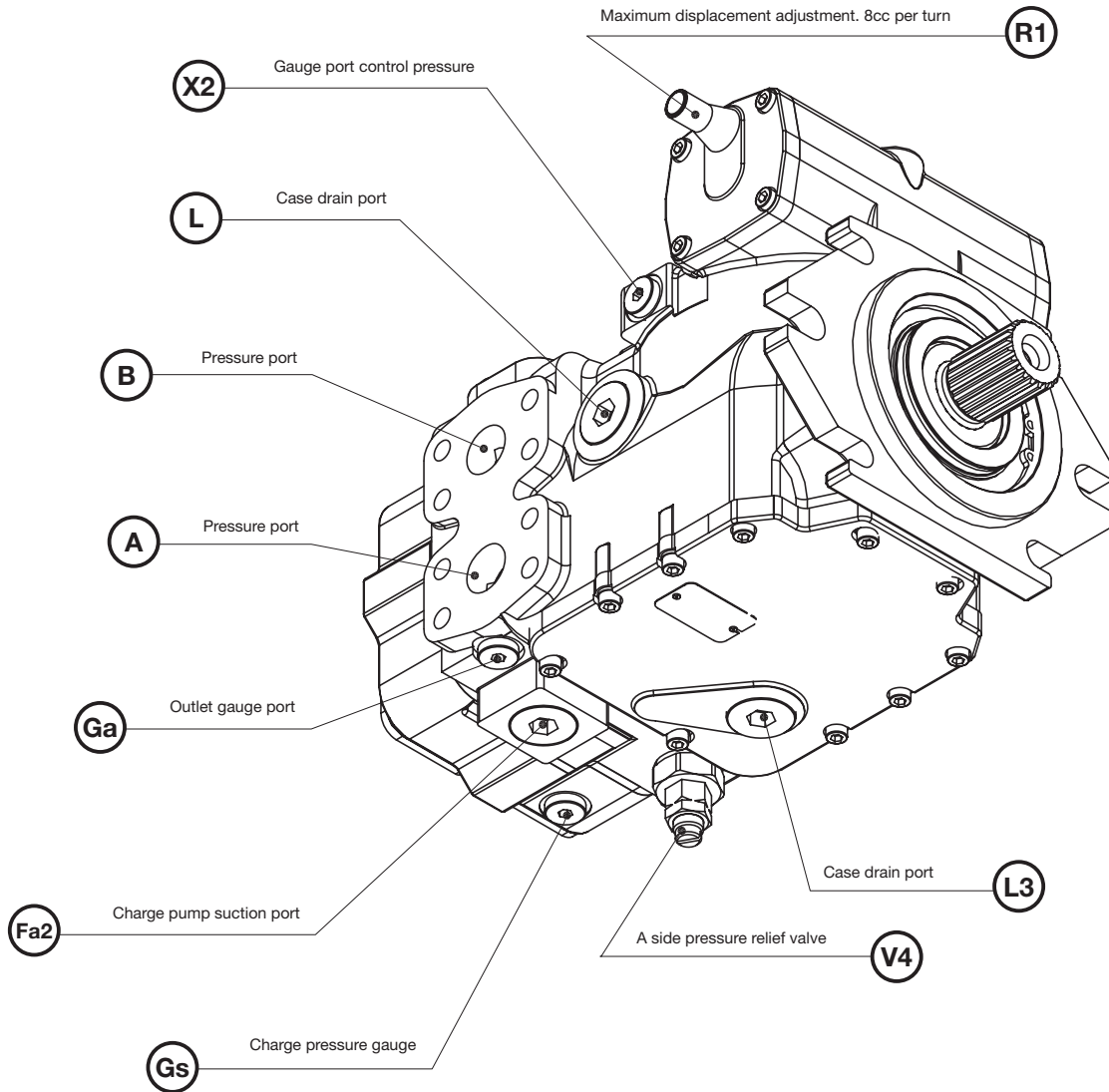

Schematic shown is a C081 with "F" control. No pressure override option.

C081 Port Chart		
Port	Mount C	Mount G
A	1" SAE Code 62	1" SAE Code 62
B	1" SAE Code 62	1" SAE Code 62
L1	-12 SAE ORB	3/4" G
L2	-12 SAE ORB	3/4" G
L3	-12 SAE ORB	3/4" G
FA1	-16 SAE ORB	1" G
FA2	-16 SAE ORB	1" G
GA	-4 SAE ORB	1/4" G
GB	-4 SAE ORB	1/4" G
GS	-4 SAE ORB	1/4" G
PS	-4 SAE ORB	1/4" G
P1	-4 SAE ORB	1/4" G
P2	-4 SAE ORB	1/8" G
P3	-4 SAE ORB	1/8" G
X1	-4 SAE ORB	1/4" G
X2	-4 SAE ORB	1/4" G
GT	-4 SAE ORB	1/4" G

C Series Displacement Controls				
Mount	Control Code	Control Modifier	Description	Part Number
All	A	000	A000 controller, manual lever	S2F-19950-5
C/D	C	SELECT KIT	C CONT NO ORF HPDCF SAE S2	S2F-20229-5
G/H	C	SELECT KIT	C CONT, NO ORF HPDCF ISO S2	S2F-20228-5
C/D	D	000	D000 controller, HPDCN, no orifice, SAE	S2F-19962-5
G/H	D	000	D000 controller, HPDCN, no orifice, ISO	S2F-19963-5
C/D	D	005	D005 controller, HPDCN, .5 mm orifice, SAE	S2F-19964-5
G/H	D	005	D005 controller, HPDCN, .5 mm orifice, ISO	S2F-19965-5
C/D	D	009	D009 controller, HPDCN, .9 mm orifice, SAE	S2F-19966-5
G/H	D	009	D009 controller, HPDCN, .9 mm orifice, ISO	S2F-19967-5
All	E/J	212/D2*/E2*	E212 controller, ENPDC, 1.2 mm orifice, 12V S2	S2F-19968-5
All	E/J	212/F2*/G2*	E412 controller, ENPDC, 1.2 mm orifice, 24V S2	S2F-19973-5
All	F	SELECT KIT	F CONT, NO ORF EPDCF 12V S2	S2F-20230-5
All	F	SELECT KIT	F CONT, NO ORF EPDCF 24V S2	S2F-20231-5
All	G	208	G208 controller, EPDCN, 0.8 mm orifice, 12VDC	S2F-19984-5
All	G	408	G408 controller, EPDCN, 0.8 mm orifice, 24VDC	S2F-19985-5
C/D	H	SELECT KIT	H CONT, NO ORF EPDCFH 12V SAE	S2F-20232-5
C/D	H	SELECT KIT	H CONT, NO ORF EPDCFH 24V SAE	S2F-20233-5
C/D	H	SELECT KIT	H CONT, NO ORF EPDCFH 12V ISO	S2F-20234-5
C/D	H	SELECT KIT	H CONT, NO ORF EPDCFH 24V ISO	S2F-20235-5
All	J	D5*/E5*	E215 controller, ENPDC, 1.5 mm orifice, 12VDC, J control only	S2F-19990-5
All	J	F5*/G5*	E415 controller, ENPDC, 1.5 mm orifice, 24VDC, J control only	S2F-19991-5
C/D	K	Any	K control only, SAE ports	S2F-19992-5
G/H	K	Any	K control only, ISO ports	S2F-19993-5

Use control modifier in unit model code to select correct control orifice kit for "C", "F", and "H" controls.

Please note that "C", "F", and "H" controls above do not have orifices installed. Orifices must be installed prior to installation onto unit. For more information reference product update bulletin PC-0061.

Control Orifice Kits	
Description	Part Number
Orifice Kit, 0.6 mm	S2F-20236-5
Orifice Kit, 0.7 mm	S2F-20237-5
Orifice Kit, 0.8 mm	S2F-20238-5
Orifice Kit, 0.9 mm	S2F-20239-5
Orifice Kit, 1.0 mm	S2F-20240-5
Orifice Kit, 1.2 mm	S2F-20241-5
Orifice Kit, 1.5 mm	S2F-20242-5
Orifice Kit, 2.0 mm	S2F-20244-5

Exploded View

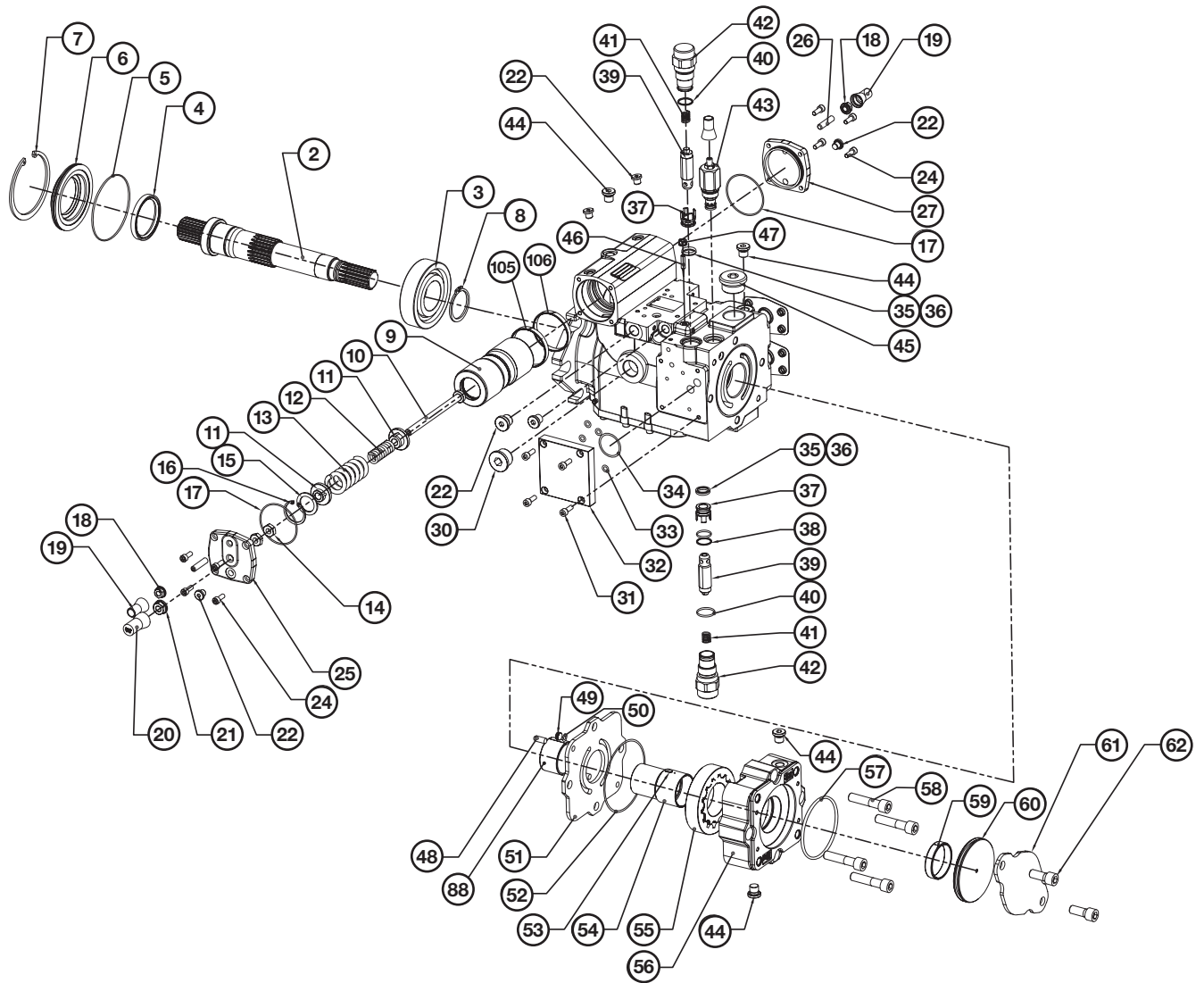

Torque Chart		
Item #	Description	Torque N-m (ft-lb)
18	Hex head nut	30 (22)
21	Hex head nut	40 (29)
22	-4 SAE ORB plug	20 (15)
30	-12 SAE ORB plug	101 (75)
31	Socket head screw	15 (11)
42	Valve cap	140 (103)
43	Charge relief lock nut	40 (29)
43	Charge relief body	50 (37)
44	-4 SAE ORB plug	20 (15)
45	-16 SAE ORB plug	150 (111)
47	Hex head nut	15 (11)
58	Socket head screw	80 (59)
67	Socket head screw	15 (11)
68	Socket head screw	10 (7)

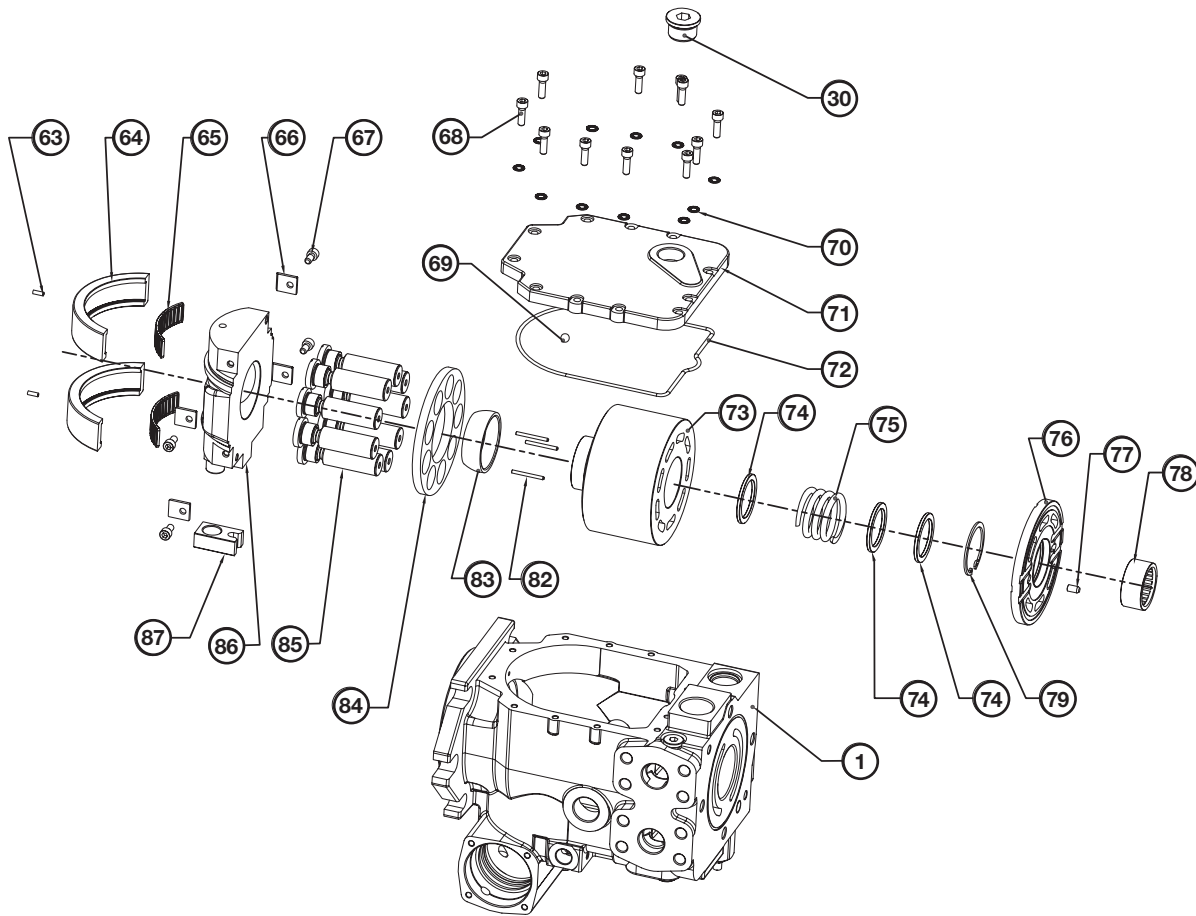

Torque Chart

Item #	Description	Torque N-m (ft-lb)
18	Hex head nut	30 (22)
21	Hex head nut	40 (29)
22	-4 SAE ORB plug	20 (15)
30	-12 SAE ORB plug	101 (75)
31	Socket head screw	15 (11)
42	Valve cap	140 (103)
43	Charge relief lock nut	40 (29)
43	Charge relief body	50 (37)
44	-4 SAE ORB plug	20 (15)
45	-16 SAE ORB plug	150 (111)
47	Hex head nut	15 (11)
58	Socket head screw	80 (59)
67	Socket head screw	15 (11)
68	Socket head screw	10 (7)

Bill of Material

C081 Bill of Material			
Balloon #	Description	Qty	Kit
1	Pump housing	1	Housing kit
2	Shaft	1	Shaft assembly kit
3	Bearing	1	Shaft assembly kit
4*	Shaft seal	1	Shaft retainer kit
5*	Seal	1	Shaft retainer kit
6	Seal retainer	1	Shaft retainer kit
7	Snap ring	1	Shaft assembly kit
8	Snap ring	1	Shaft assembly kit
9	Servo piston	1	Servo piston kit
10	Threaded rod	1	Servo piston kit
11	Spring guide	2	Servo piston kit
12	Inner spring	1	Servo piston kit
13	Outer spring	1	Servo piston kit
14	Hex head nut	2	Servo piston kit
15	Spacer	1	Servo piston kit
16	Snap ring	1	Servo piston kit
17*	O-ring	2	Servo cap kit
18	M6 Hex head nut	2	Servo cap kit
19	Protective cap	2	NO KIT
20	Protective cap	1	NO KIT
21	M10 Hex head nut	1	Servo cap kit
22*	-4 SAE ORB plug	3	Servo cap kit
24	Socket head screw	4	Servo cap kit
25	Servo cap with centering	1	Servo cap kit
26	Threaded rod	4	Servo cap kit
27	Servo cap no centering	1	Servo cap kit
30**	-12 SAE ORB plug	4	Housing cover kit
31	M6x18 Socket head screw	4	Override and options kits
32	Accessory block	1	Override kits/Charge filter kits
33*	O-ring	4	Override kits/Charge filter kits
34*	O-ring	1	Override kits/Charge filter kits
35*	O-ring	4	Relief assembly kits
36*	O-ring	4	Relief assembly kits
37	Valve seat	2	Relief assembly kits
38*	O-ring	2	Relief assembly kits
39	Valve assembly	2	Relief assembly kits
40*	O-ring	2	Relief assembly kits
41*	O-ring	2	Relief assembly kits
42	Valve cap	2	Relief assembly kits
43	Charge pressure relief	1	Charge relief kit
44**	-4 SAE ORB plug	4	Charge pump kits
45	-16 SAE ORB plug	2	NO KIT

C081 Bill of Material			
Balloon #	Description	Qty	Kit
46	Throttle valve	1	Throttle valve kit
47	M6 Seal nut	1	Throttle valve kit
48	Dowel pin	1	Bushing kit
49	Plug	1	Seal kit
50	Seal	1	Seal kit
51	Spacer	1	Charge pump kits
52*	O-ring	2	Charge pump kits
53	Key	1	Charge pump kits
54	Coupling	1	Charge pump kits
55	Gerotor	1	Charge pump kits
56	Charge pump housing	1	Charge pump kits
57*	O-ring	1	Charge pump kits
58	M12x55 Socket head screw	4	Through drive kits
59	Bushing	1	Charge pump kits
60	Blocking cover	1	Charge pump kits
61	Gerotor cap	1	Through drive kits
62	Socket head screw	2	Through drive kits
63	Dowel pin	2	Swash plate kit
64	Swash bearing guide	2	Swash plate kit
65	Bearing	2	Swash plate kit
66	Bearing stop	4	Swash plate kit
67	M6x12 Socket head screw	4	Swash plate kit
68	M6x18 Socket head screw	11	Housing cover kit
69	Ball	1	Housing cover kit
70	Lock washer	11	Housing cover kit
71	Cover	1	Housing cover kit
72*	O-ring	1	Housing cover kit
73	Barrel	1	Rotating group
74	Spacer	3	Rotating group
75	Spring	1	Rotating group
76	Valve plate	1	Valve plate kit
77	Pin	1	Valve plate kit
78	Bearing	1	Housing bearing kit
79	Snap ring	1	Rotating group
82	Pin	3	Rotating group
83	Ball seat	1	Rotating group
84	Retainer	1	Rotating group
85	Piston	9	Rotating group
86	Swash plate	1	Swash plate kit
87	Feedback link	1	Swash plate kit
88	Bushing	1	Bushing kit
105*	Seal guide	2	Seal kit
106*	Ring seal	2	Seal kit

*items are part of the pump seal kit
**hardware item used in multiple kits



Kits

Seal Kit	
Includes all seals for the pump	S2F-20036-5

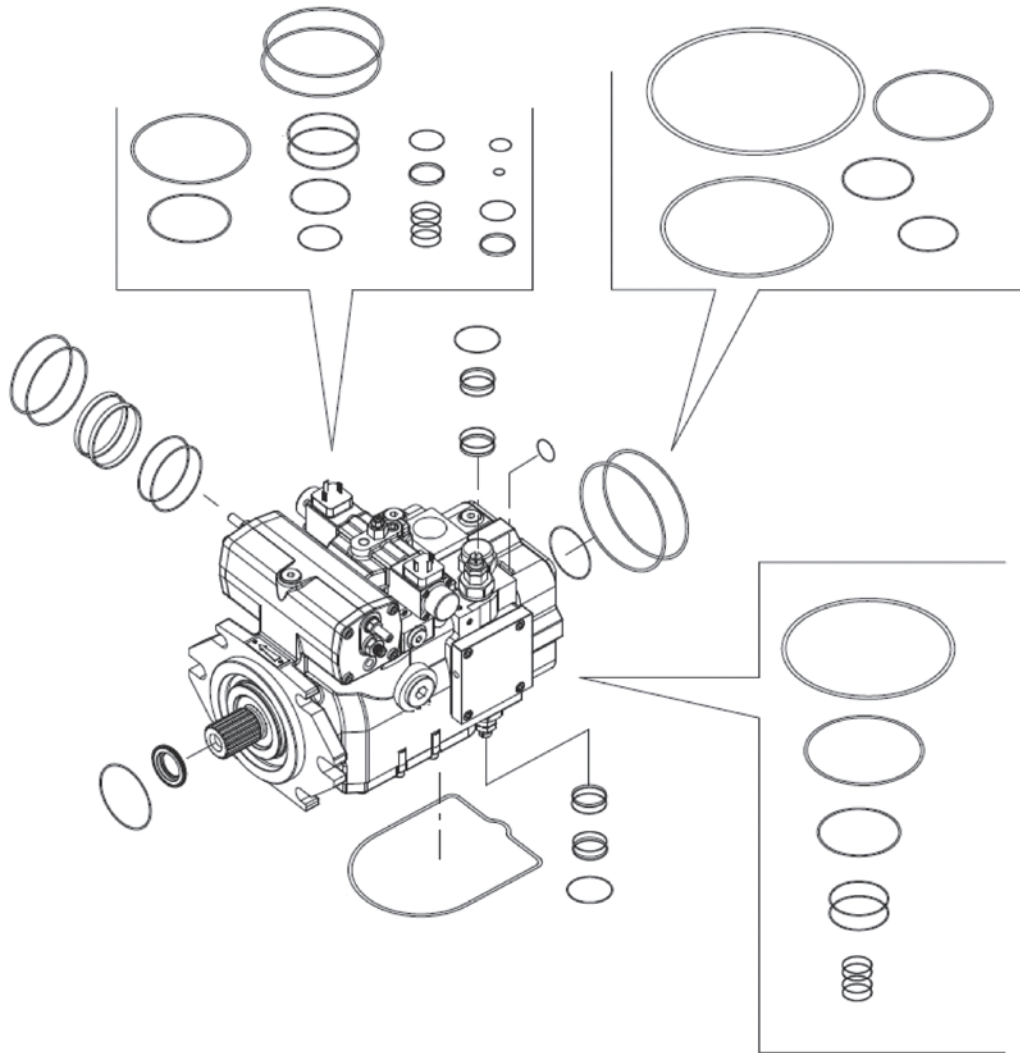

Kits

Housing		
Mount Option	Description	Part Number
C	C081 SAE C 2/4 bolt mount with SAE ports	S2F-19909-5
G	C081 SAE C 2/4 bolt mount with ISO ports	S2F-19910-5

If needing housing for units J or K control option contact technical support

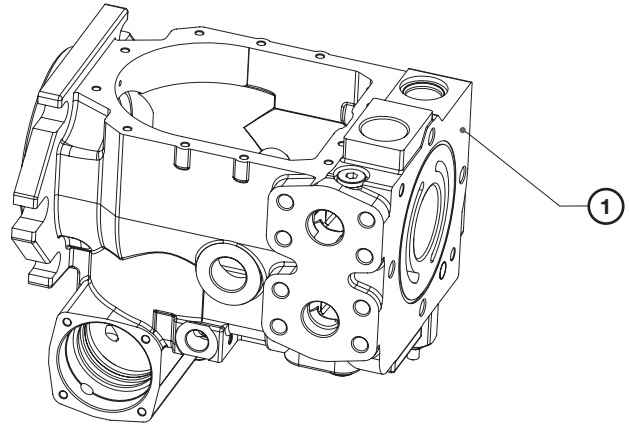

Housing Cover Kit		
Mount Option	Description	Part Number
C	C081 Housing cover kit SAE	S2F-19937-5
G	C081 Housing cover kit ISO	S2F-19949-5

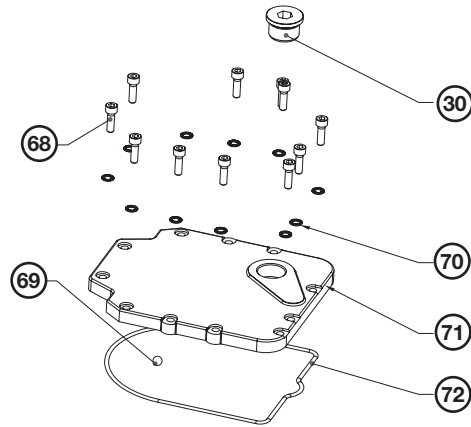

Shaft Assembly Kit		
Shaft Option	Description	Part Number
1	SAE C 14T 12/24 DP shaft kit C081	S2F-19911-5
2	SAE 21T 16/32 DP shaft kit C081	S2F-19912-5

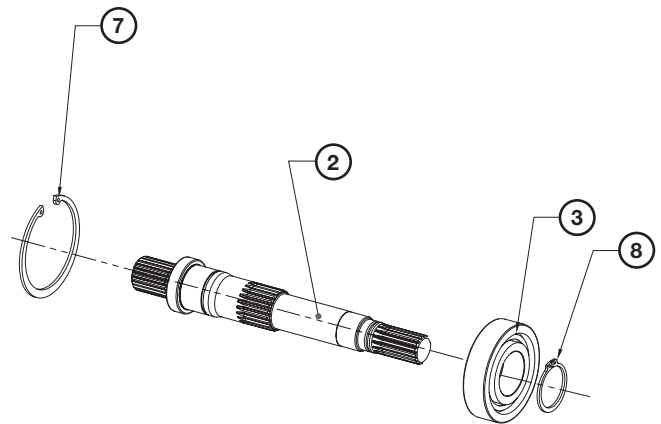

Shaft Retainer Kit	S2F-19913-5
--------------------	-------------

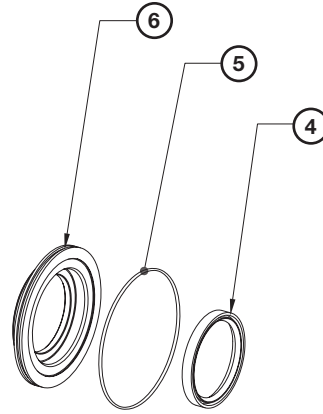

Swashplate Kit	S2F-19944-5
----------------	-------------

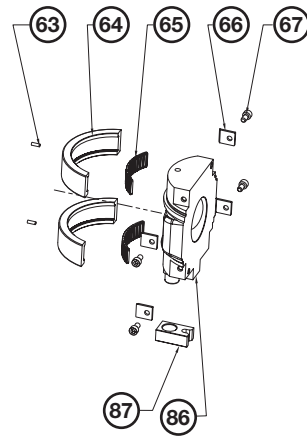

Rotating Group	S2F-19945-5
----------------	-------------

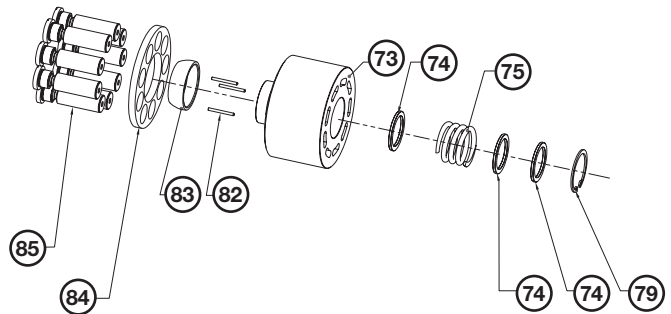

Kits

Valve Plate Kit		
Rotation	Description	Part Number
R	C081 CW rotation kit	S2F-19946-5
L	C081 CCW rotation kit	S2F-19947-5

Consult factory for control options J/K.

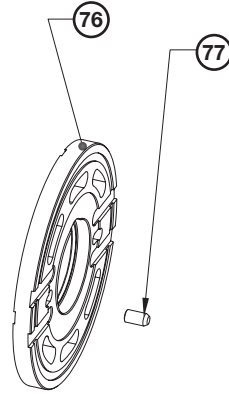

Housing Bearing	S2F-20035-5
------------------------	-------------



Bushing Kit	S2F-20032-5
--------------------	-------------

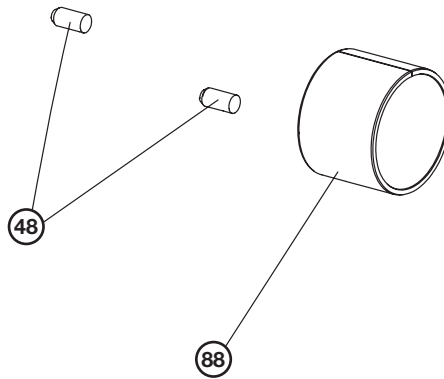

Throttle Valve Kit	S2F-20034-5
---------------------------	-------------

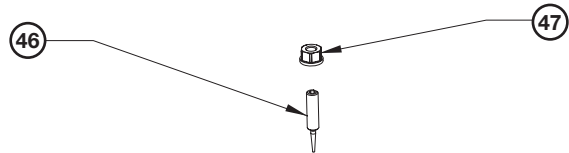

Servo Piston Kit	S2F-19914-5
------------------	-------------

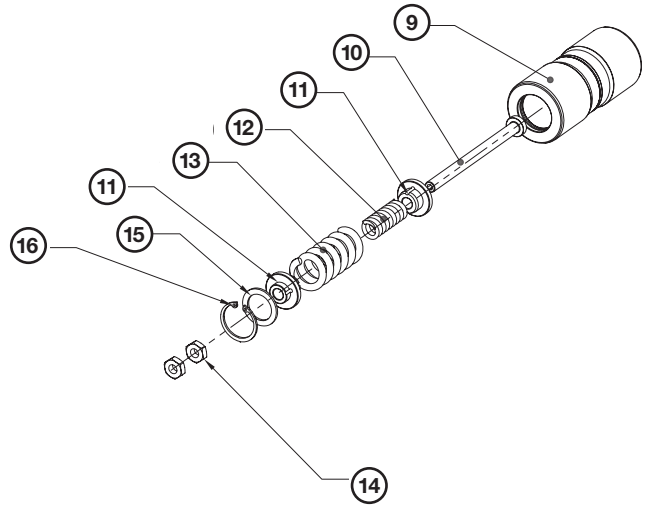

Servo Cap Kit	S2F-19948-5
---------------	-------------

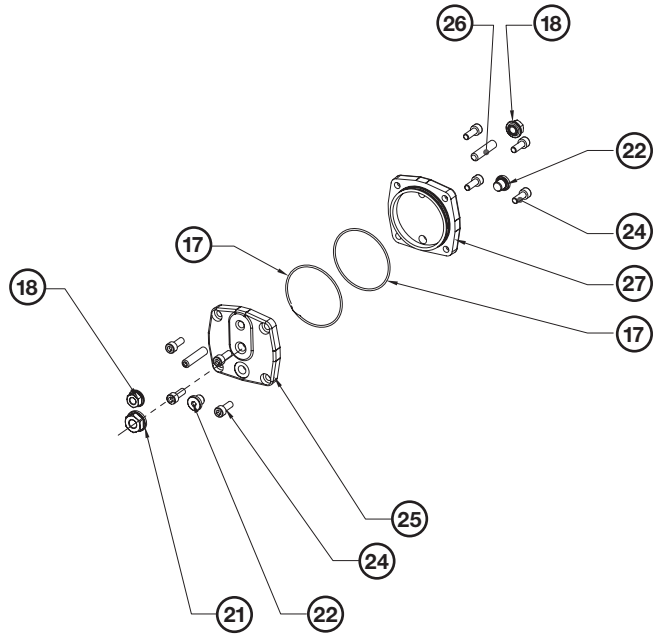

Kits

Charge Pump Kits			
Mount Options	Charge Pump Option	Description	Part Number
C	A	18cc kit with SAE ports C081	S2F-19930-5
G	A	18cc kit with ISO ports C081	S2F-19931-5
C	B	23cc kit with SAE ports C081	S2F-19932-5
G	B	23cc kit with ISO ports C081	S2F-19933-5
C	C	27cc kit with SAE ports C081	S2F-19934-5
G	C	27cc kit with ISO ports C081	S2F-19935-5
Any	X	Blocking kit C081	S2F-19936-5

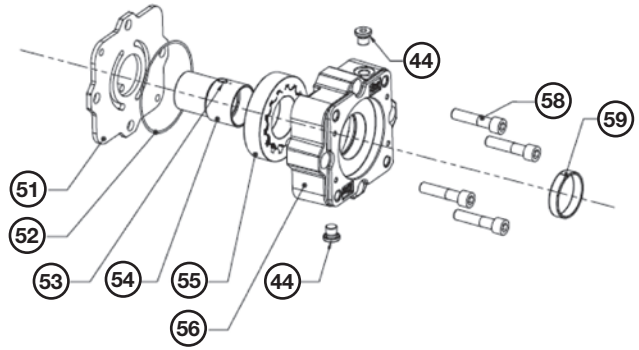

Through Drive Kits		
Through Drive Option	Description	Part Number
X	Through drive blanking kit	S2F-19938-5
A	C081 SAE A Through drive kit, 2 blt w/ 9T coupling	S2F-19939-5
B	C081 SAE B Through drive kit, 2 blt w/ 13T coupling	S2F-19940-5
G	C081 SAE B Through drive kit, 2 blt w/ 15T coupling	S2F-19941-5
C	C081 SAE C Through drive kit, 2/4 blt w/ 14T coupling	S2F-19942-5
H	C081 SAE C Through drive kit, 2/4 blt w/ 17T coupling	S2F-19943-5
E	Order C option through drive kit	

Through Drive Blanking Kit

Torque to 105 Nm (77ft-lbs)

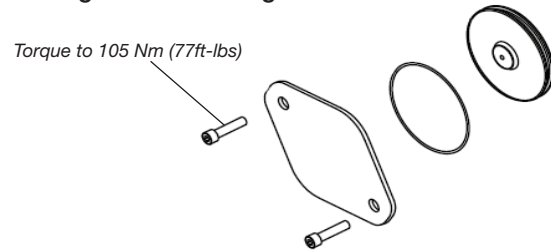

Option A Kit

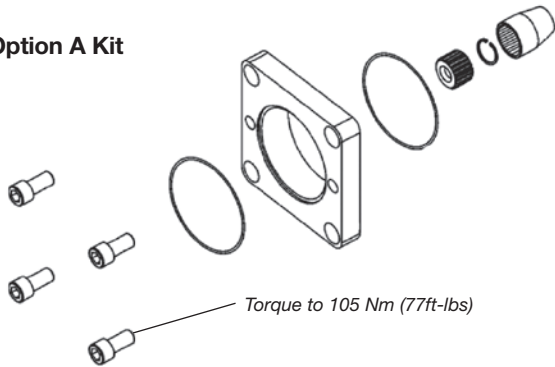

Torque to 105 Nm (77ft-lbs)

Option B & G Kit

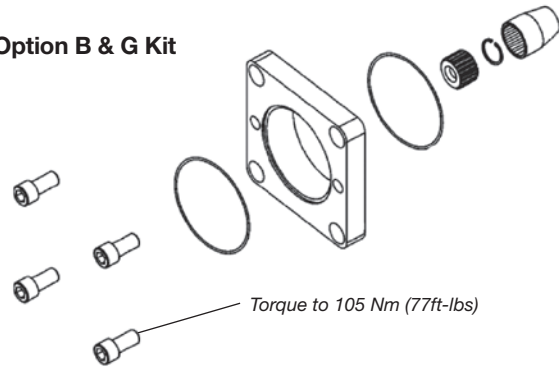

Torque to 105 Nm (77ft-lbs)

Option C & H Kit

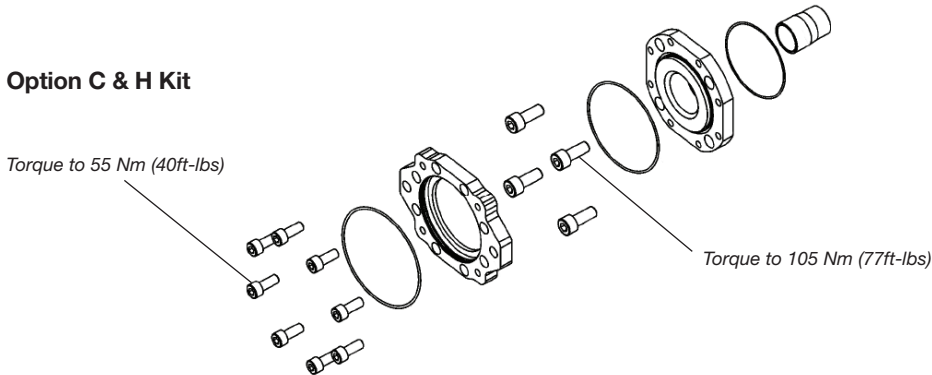

Torque to 55 Nm (40ft-lbs)

Torque to 105 Nm (77ft-lbs)

Override Kits/Charge Filter Options						
Mount	Pressure override	Override Option	Charge filtration	Description	Part number	Additional part number
C/G	X	XX	X	Accessory blocking plate	S2F-19915-5	-
C	X	XX	R	Remote charge filter, no override, SAE ports	S2F-19922-5	-
C/G	*	*	N	Charge filter assembly with mechanical 8 bar indicator	S2F-19920-5	-
C/G	*	*	G	Charge filter assembly with electrical 8 bar indicator	S2F-19921-5	-
C/G	P	*	X	Pressure override	S2F-19916-5	-
C	P	*	R	Remote charge filter block with mechanical POR, SAE ports	S2F-19923-5	-
G	P	*	R	Remote charge filter block with mechanical POR, ISO ports	S2F-19924-5	-
C/G	P	*	N/G	Mechanical POR assembly for charge filter	S2F-19919-5	-
C/G	E	12	*	Electrical override 12 VDC	S2F-19917-5	-
C/G	E	24	*	Electrical override 24 VDC	S2F-19918-5	-
C/G	C	2*	X	Mechanical POR with 12 VDC electrical override	S2F-19917-5	S2F-19916-5
C/G	C	4*	X	Mechanical POR with 24 VDC electrical override	S2F-19918-5	S2F-19916-5
				Replacement element for charge filter	S2F-20040-5	-

*any valid option
 For C pressure override codes both electrical and mechanical override are used.

S2F-19915-5

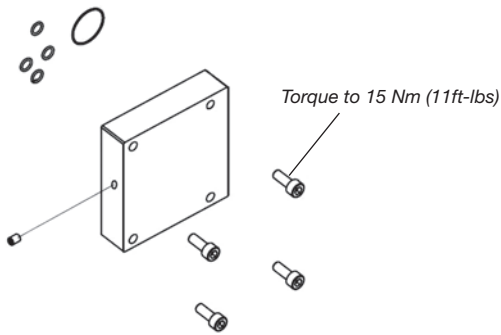

S2F-19922-5

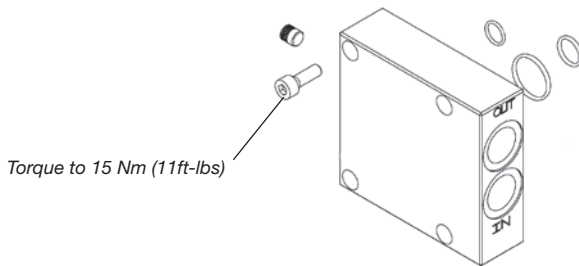

S2F-19916-5

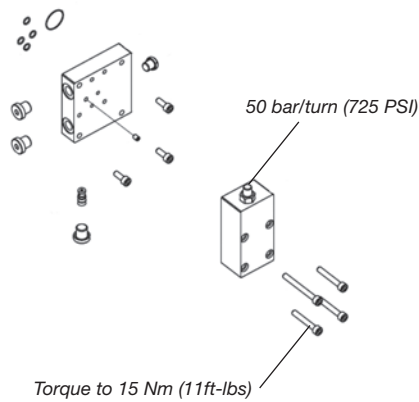

S2F-19917-5
 S2F-19918-5

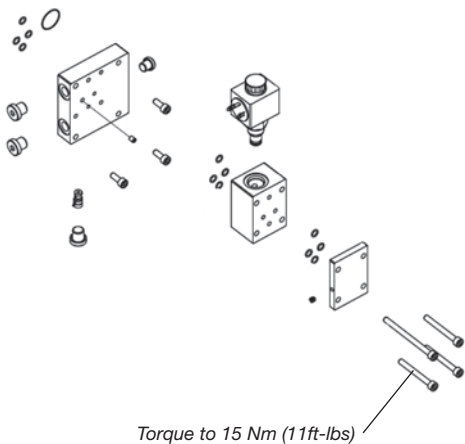

Kits

Override Kits/Charge Filter Options						
Mount	Pressure override	Override Option	Charge filtration	Description	Part number	Additional part number
C/G	X	XX	X	Accessory blocking plate	S2F-19915-5	-
C	X	XX	R	Remote charge filter, no override, SAE ports	S2F-19922-5	-
C/G	*	*	N	Charge filter assembly with mechanical 8 bar indicator	S2F-19920-5	-
C/G	*	*	G	Charge filter assembly with electrical 8 bar indicator	S2F-19921-5	-
C/G	P	*	X	Pressure override	S2F-19916-5	-
C	P	*	R	Remote charge filter block with mechanical POR, SAE ports	S2F-19923-5	-
G	P	*	R	Remote charge filter block with mechanical POR, ISO ports	S2F-19924-5	-
C/G	P	*	N/G	Mechanical POR assembly for charge filter	S2F-19919-5	-
C/G	E	12	*	Electrical override 12 VDC	S2F-19917-5	-
C/G	E	24	*	Electrical override 24 VDC	S2F-19918-5	-
C/G	C	2*	X	Mechanical POR with 12 VDC electrical override	S2F-19917-5	S2F-19916-5
C/G	C	4*	X	Mechanical POR with 24 VDC electrical override	S2F-19918-5	S2F-19916-5
				Replacement element for charge filter	S2F-20040-5	-

*any valid option
For C pressure override codes both electrical and mechanical override are used.

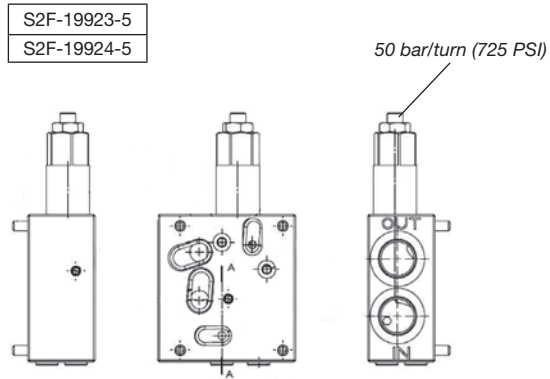

POR cartridge is available as a separate option.

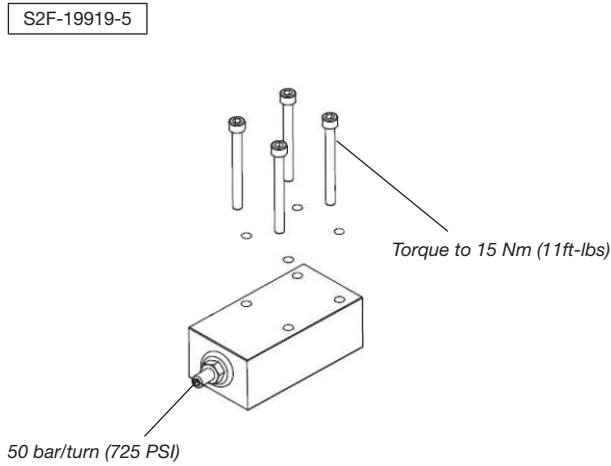
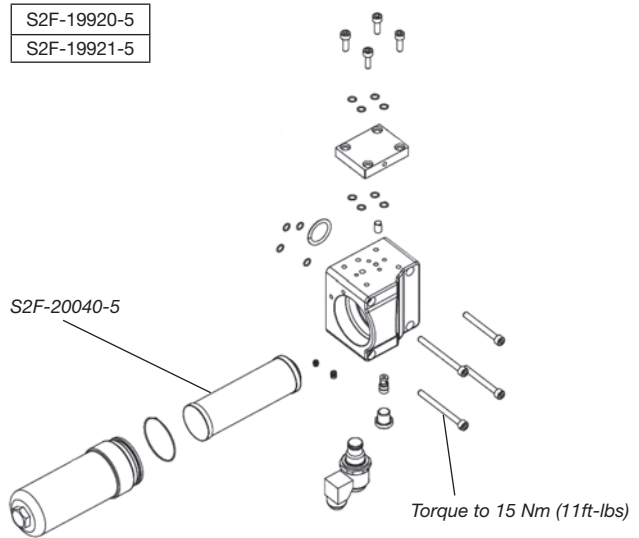

Kits

Automotive Control Valve and Accessories	
Description	Part Number
Automotive control valve with inching ISO ports	S2F-20060-5
Flushing valve with 1.5 mm orifice	S2F-20061-5
Flushing valve with 2.0 mm orifice	S2F-20062-5
Flushing valve with 2.5 mm orifice	S2F-20063-5
Flushing valve with blanking plate	S2F-20064-5

Items will only mount onto units shipped with J/K controls. If attempting to convert a non J/K control unit contact Technical Support for assistance.

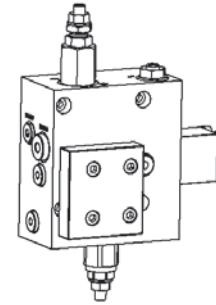

Pressure Override Cartridge	S2F-20013-5
Item includes cartridge and O-rings only	



Charge Pressure Relief	S2F-19929-5
Cartridge and O-rings	

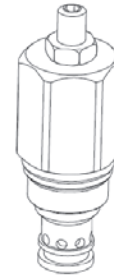

Relief Assembly Kits		
Cross Port Code	Description	Part Number
A	250 bar relief assembly	S2F-19925-5
B	350 bar relief assembly	S2F-19926-5
C	420 bar relief assembly	S2F-19927-5
D	450 bar relief assembly	S2F-19928-5

Kits include items 1 through 8.

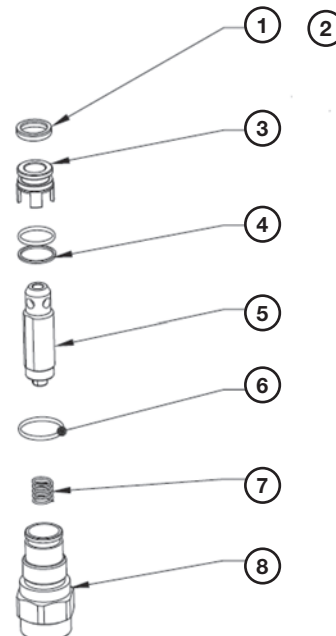

Relief Only		
Cross Port Code	Description	Part Number
A	250 bar relief assembly	S2F-20041-5
B	350 bar relief assembly	S2F-20042-5
C	420 bar relief assembly	S2F-20043-5
D	450 bar relief assembly	S2F-20044-5

Kits include item 5 only.



Disassembly and Assembly

Disassembly Procedure

During the following disassembly and reassembly procedures, refer to the exploded view and part list.

The disassembling procedure is obtained following the assembling procedure but started from the end. See assembling procedure section.

Component Condition Checks

- Check shaft end spline wear or parallel shaft end key groove and key for wear or fractures.
- Check bearings for wear. If necessary, they must be replaced.
- Visually check piston bores in the cylinder barrel and pistons sides: no scratches or seizure marks can be visible. Check pistons diameter A and bores diameter D (see figure 2). Replace the parts if out of tolerance.
- Check axial play B and tilting movement C between pistons components. See figure 2 for values. Replace parts if values are out of tolerance.
- Check contact surfaces between cylinder barrel and valve plate: no wear marks, scores or dents must be visible. If visible, replace parts.
- Check swash plate wear: no deep marks or scores are to be accepted. If visible, replace parts.
- Check thickness tolerance between charge pump gerotor and charge pump casing. Gerotor set must be from 0.05 mm to 0.08 mm lower than the charge pump casing.

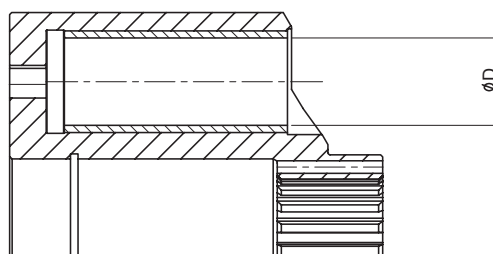
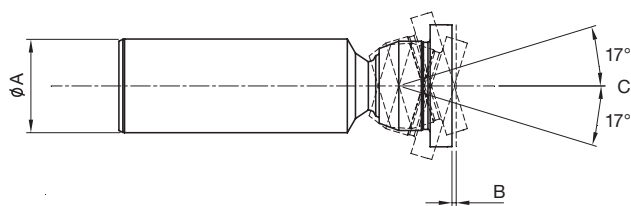
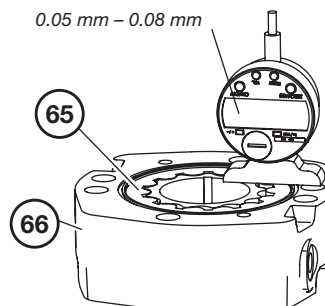

Figure 2

	Piston Diameter A (mm)	Piston Slipper End Movement B (mm)	Slipper Angle (Max) C (°)	Piston Bore Diameter D (mm)
C081	21.485 - 21.5	0.05 - 0.10	17	21.5 - 21.535

Assembly Procedure

The following procedure requires a careful cleaning and degreasing of all the parts before starting to reassemble the unit.

A properly cleaned bench with a vice (with aluminum alloy jaw guards) and a good lighting are also mandatory. Standard workshop tooling, filtered hydraulic oil and clean petroleum jelly must be available.

WARNING:

Screw the socket head screw M6x55-12.9 UNI 5931 in the seat restrictor (46) and then mount expander plug (100). Unscrew the socket head screw M6x55-12.9 UNI 5931 and screw the screw orifice (46).

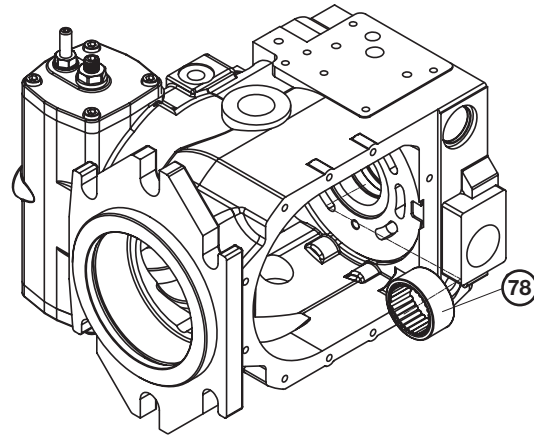

2. Mount needle roller bearing (78) inside pump casing (1). To do so, a press and a suitable tool should be used.

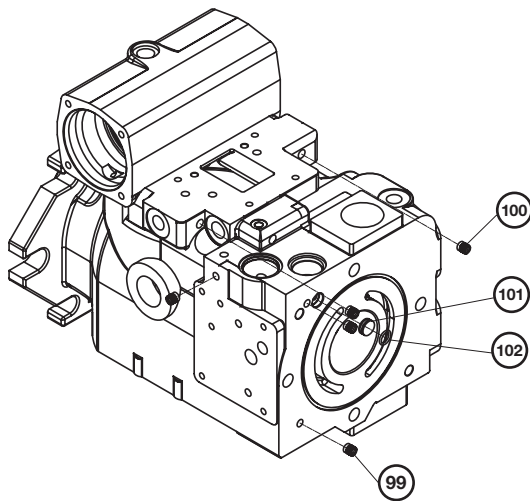
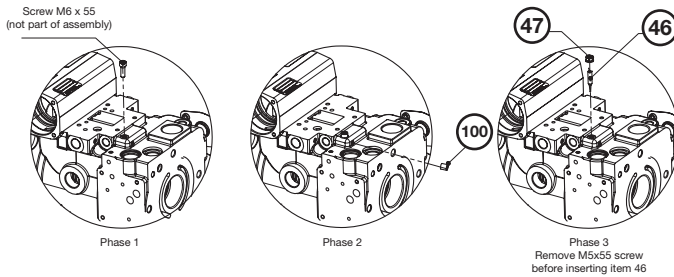

1. Mount expander plugs (99) and (100) and plug (101) with its O-ring (102) on pump casing (1).

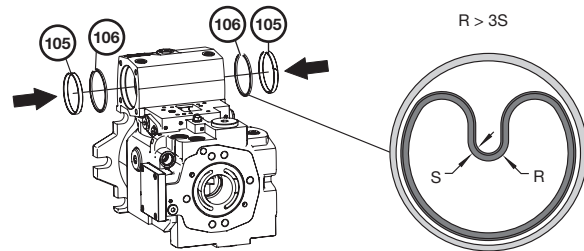
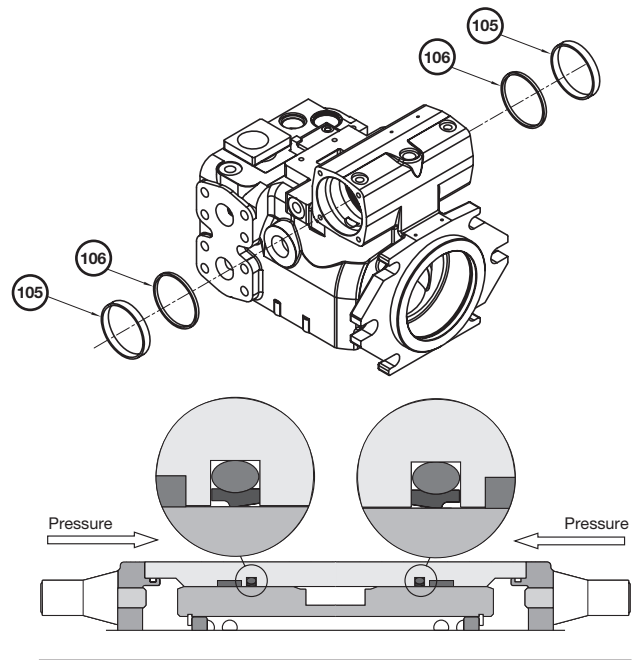

3. Fit seal ring (106) and guide ring (105) into their grooves in the pump casing.

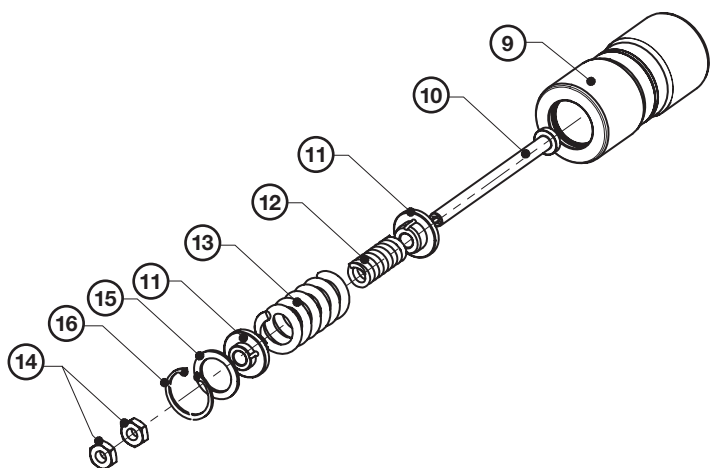

4. Mount control piston kit as shown in figure above. To mount snap ring (16) screw first nut (14) in until the snap ring groove is free. After the snap ring (13) is in position, remove any axial backlash setting nut (14) position. Use second nut (14) to lock into position.

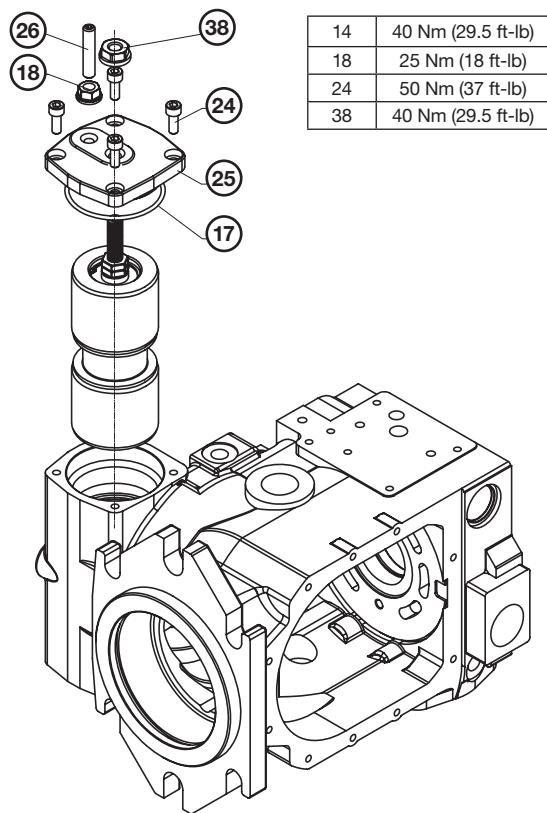

14	40 Nm (29.5 ft-lb)
18	25 Nm (18 ft-lb)
24	50 Nm (37 ft-lb)
38	40 Nm (29.5 ft-lb)

6. Mount O-ring (17) on servo cap (25) and screw the latter on threaded setting screw (15) of the control piston kit. Insert the assembly inside the seat in pump casing (1) and screw the four screws (24), the displacement setting screw (26) and seal lock nut (18). Position piston in the center by the means of the setting screw (15) and mount seal lock nut (38).

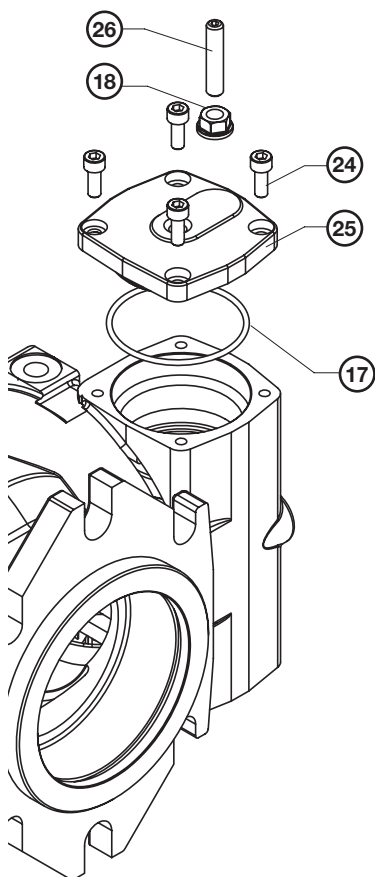

5. Mount O-ring (17) on servo cap (27). Mount servo cap (27) on pump casing with screws (24). Mount displacement setting grub screw (26) and seal lock nut (18).

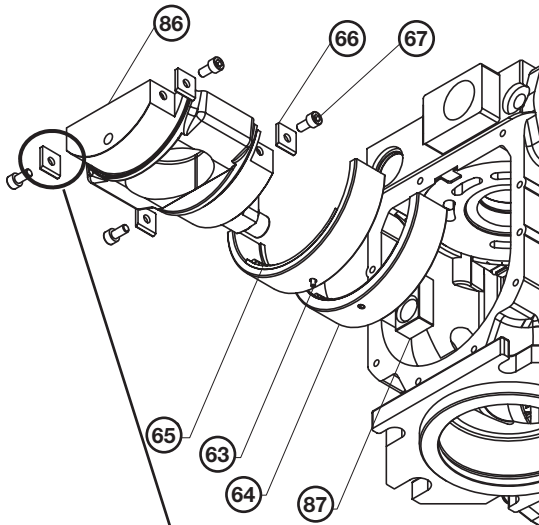

7. Mount the bearing guides (66) and screws (67) on swash plate (86). Use threadlocker (medium strength) Loctite 243 on the screw (67).

WARNING:

Respect mounting position as shown in drawing. Insert spring pins (63) in their seats of bearing races (64) and those latter inside pump casing. Mount needle bearing cages (65) on races (64). Insert swash plate feedback link (87) inside its groove in control piston (12). Mount swash plate (86) on bearing cages (65), positioning its pivot inside feedback link (87).

67	15 Nm (11 ft-lb)
----	------------------

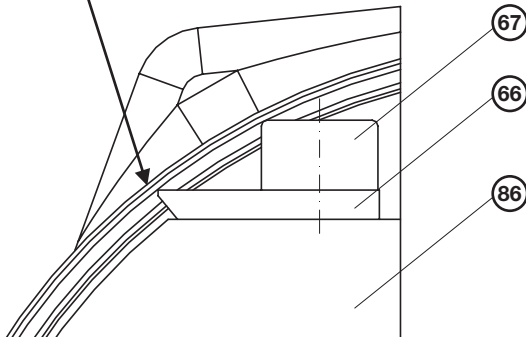

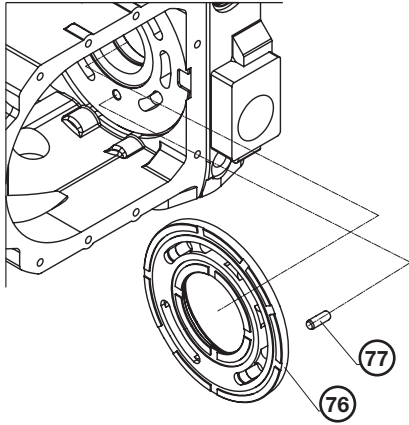

8. Make sure there are no dents or burrs on the surface of the valve plate (76), and mount it with pin (77) inside pump casing (1).

When mounting the valve plate (76), before installation, check if it is CCW (SX) for pumps left, or CW (DX) for pumps right. The direction of rotation is indicated in the gerotor pump housing (56) or in the direction plate (T) on the front of the housing pump.

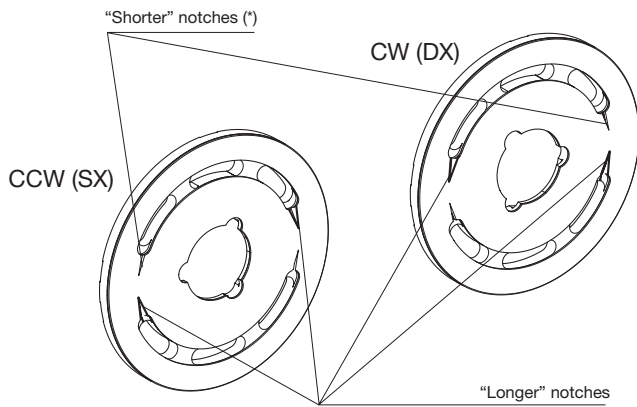

*The shorter notch is only in J/K versions.

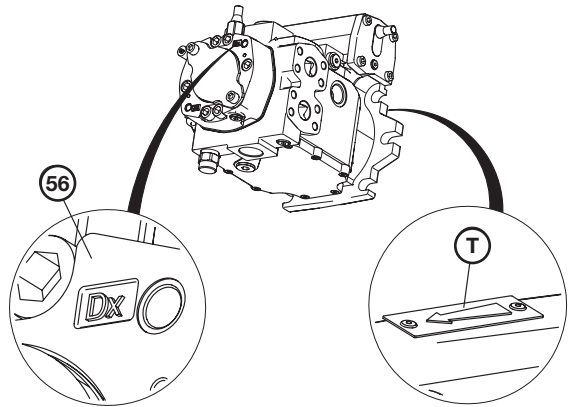

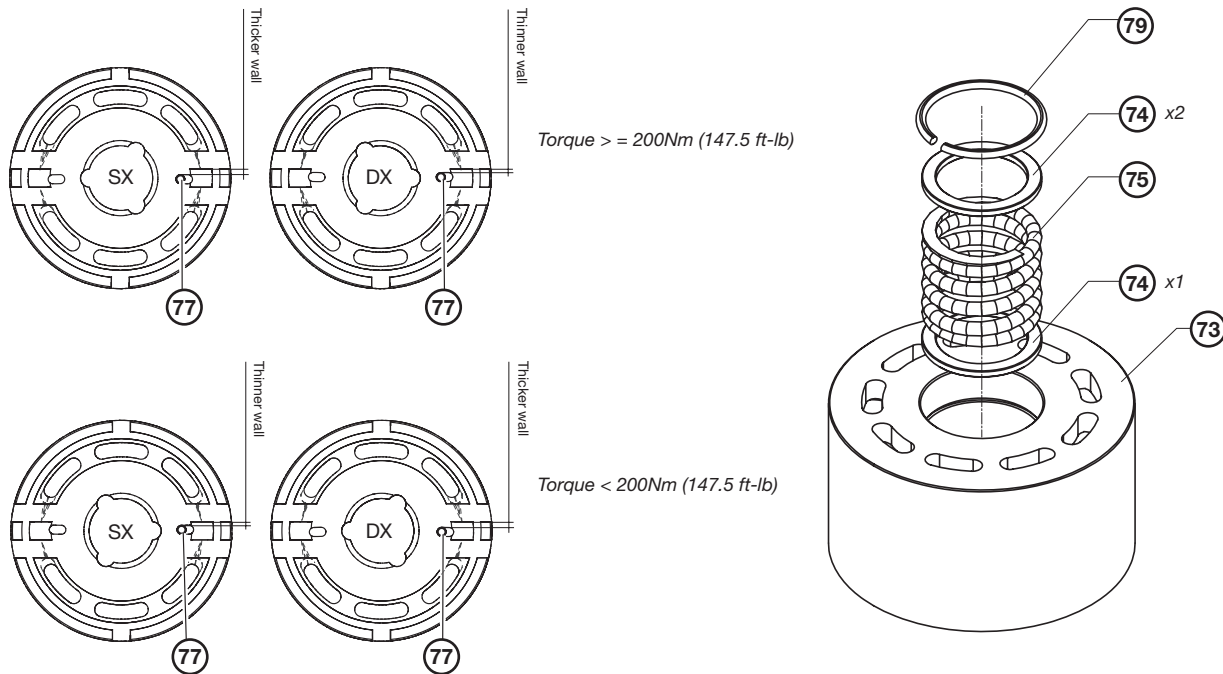

Versions with A - B - C - D - E - F - G - H control - and with J/K control with setting torque $\geq 200\text{Nm}$ [147.5 lbf-ft].

CW (DX): The thinner wall is in correspondence with the “longer” notch.

CCW (SX): The thicker wall is in correspondence with the “shorter” notch on the other side of the valve plate (The “shorter” notch is only in J/K version).

Version with J/K control (Automotive) with setting torque $< 200\text{Nm}$ [147.5lbf-ft].

CCW (SX): The thinner wall is in correspondence with the “shorter” notch on the other side of the valve plate.

CW (DX): The thicker wall is in correspondence with the “longer” notch.

9. Mount shims (74) and spring (75) inside cylinder barrel (73). Using a press, compress spring (75) and mount snap ring (79).

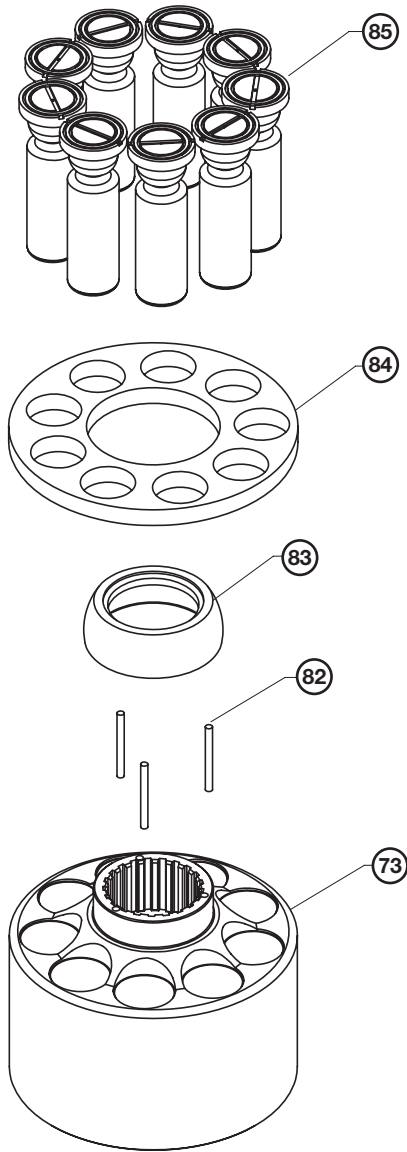

10. Insert pins (82) into their seats in cylinder barrel (73) and mount ball seat (83) on them. Fit pistons (85) into the piston retainer (84). Lubricate cylinder barrel piston bores with clean oil. Fit pistons into their bores in cylinder barrel.

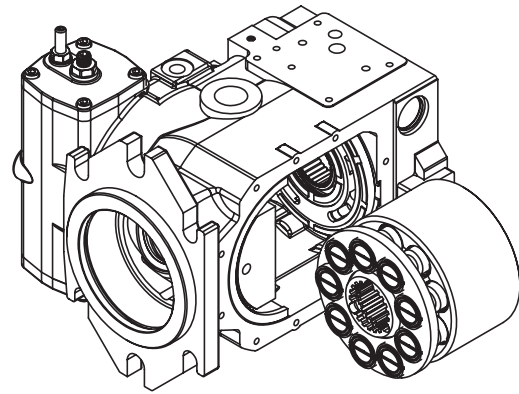

11. Mount rotating group inside pump casing. To do so, it is necessary to use special tool code S2F-20045-5 in order to compress the spring inside cylinder barrel. Attempting to mount the rotating kit without proper tooling will result in damage of components and in subsequent malfunctioning of the pump. Remove tool S2F-20045-5 after mounting the kit.

How to Use S2F-20045-5 Tool

Step 1

When inserting the S2F-20045-5 tool into the rotating group, please ensure the pin (P) is aligned with the splines.

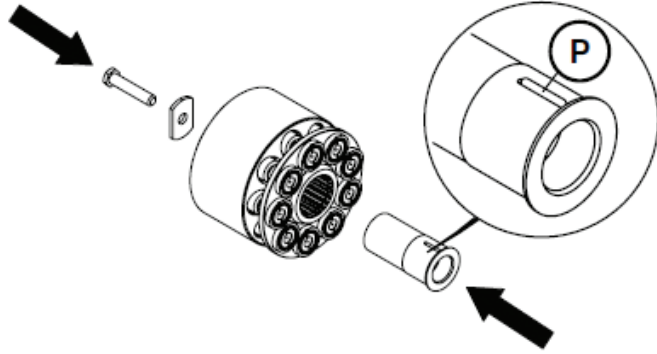

Step 2

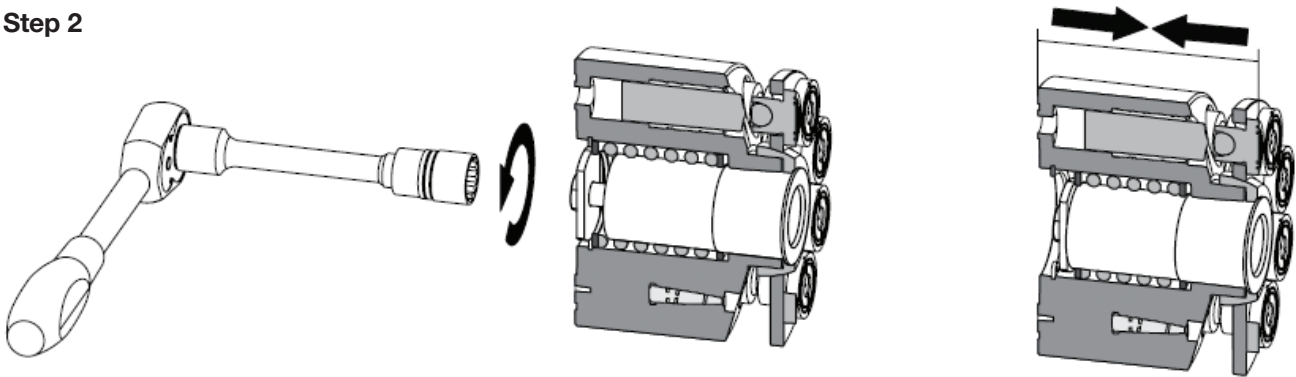

Step 3

Insert rotating group into housing and use alignment tool included in the S2F-20045-5 kit to ensure the rotating group is centered properly.

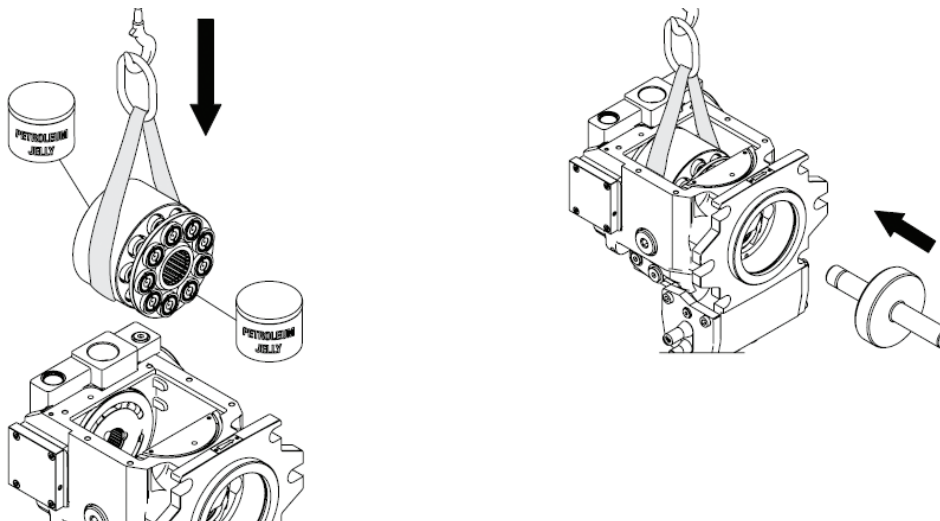

Step 4

Release bolt tension on rotating group and remove alignment tool. When removing the tool from the rotating group ensure that the pin (P) does not drop into the assembly.

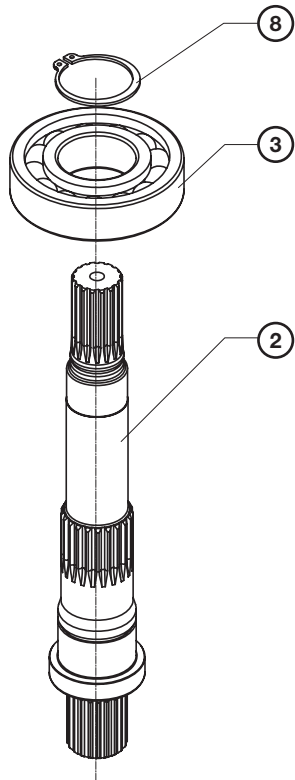
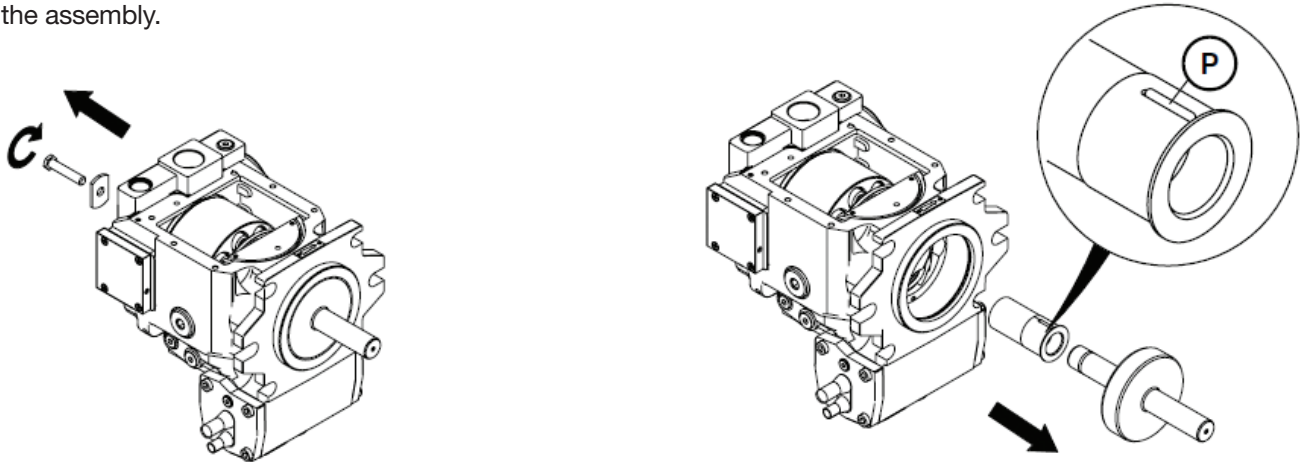

12. Mount bearing (3) on shaft (2), using a press.
Mount snap ring (8).

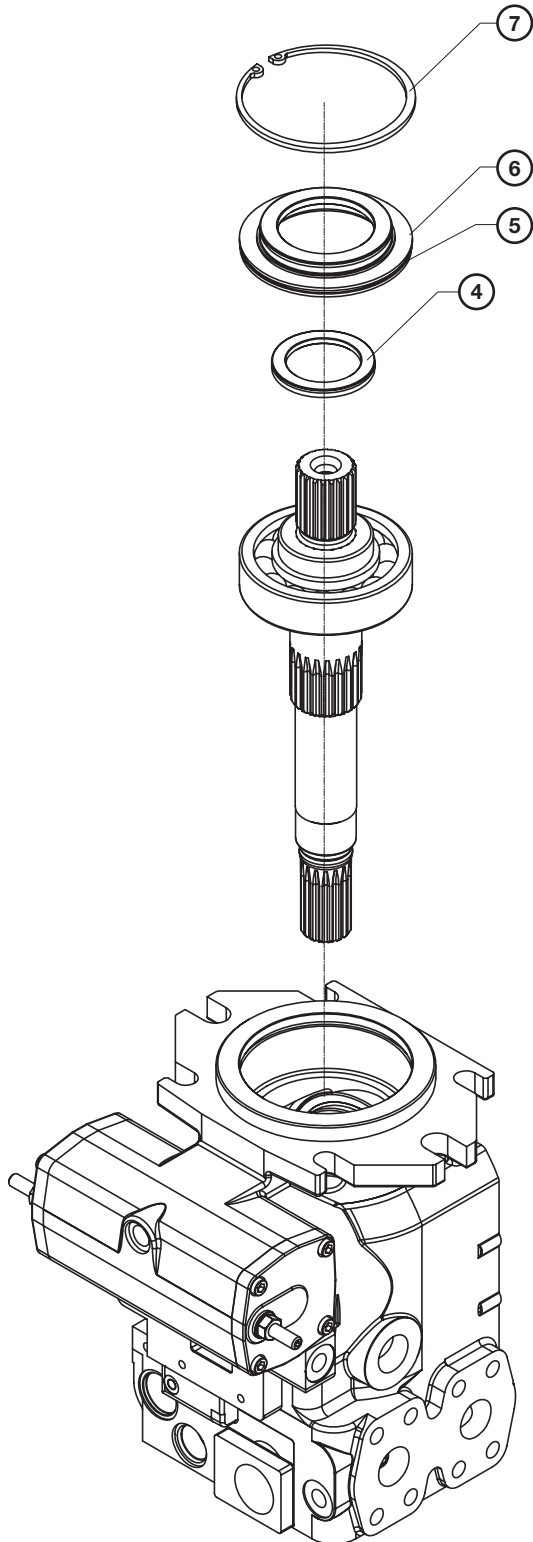

13. Mount shaft kit inside pump casing. Mount shaft seal (4) and O-ring (5) on front cover (6). Lubricate seals with grease. Mount front cover on shaft. Mount snap ring (7) into its seat in pump casing.

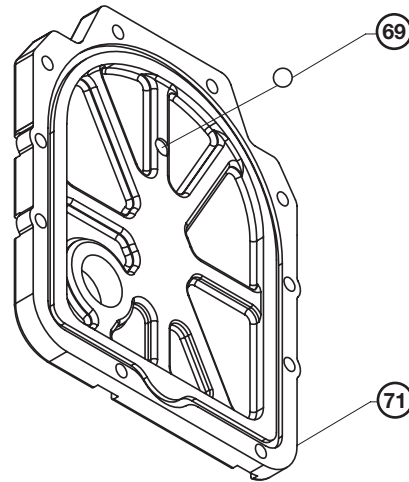

14. Press ball (69) into its seat of lower cover (71).

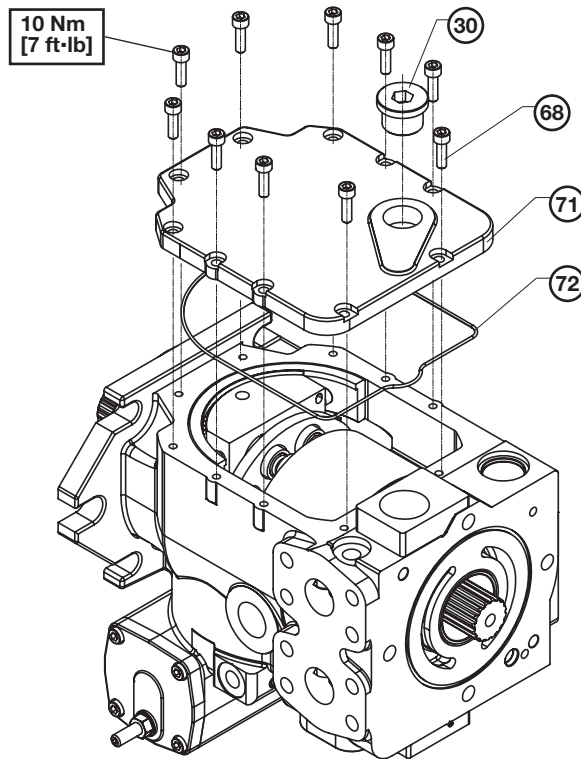

15. Mount O-ring (72) into its groove in cover (71) and place cover on pump casing. Mount screws (68) and washers (113) and torque them (see torque values). Mount plug (30) and torque (see torque values).

WARNING:
 Use thread locker **LOCTITE 243** on screws.

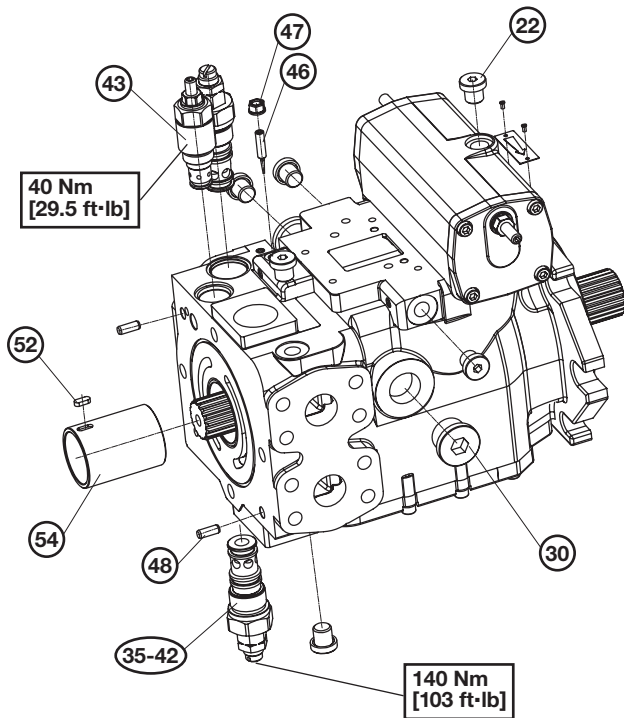

16. Mount the following parts on pump casing: boost pressure relief valve (43), max pressure relief valves (35-42), adjustable orifice (46) with locking nut (47), plugs (30) and (22), pins (48), drive coupling (54) with its circlip (76) inside and key (75). Mount rotation direction tag (49) with rivets.

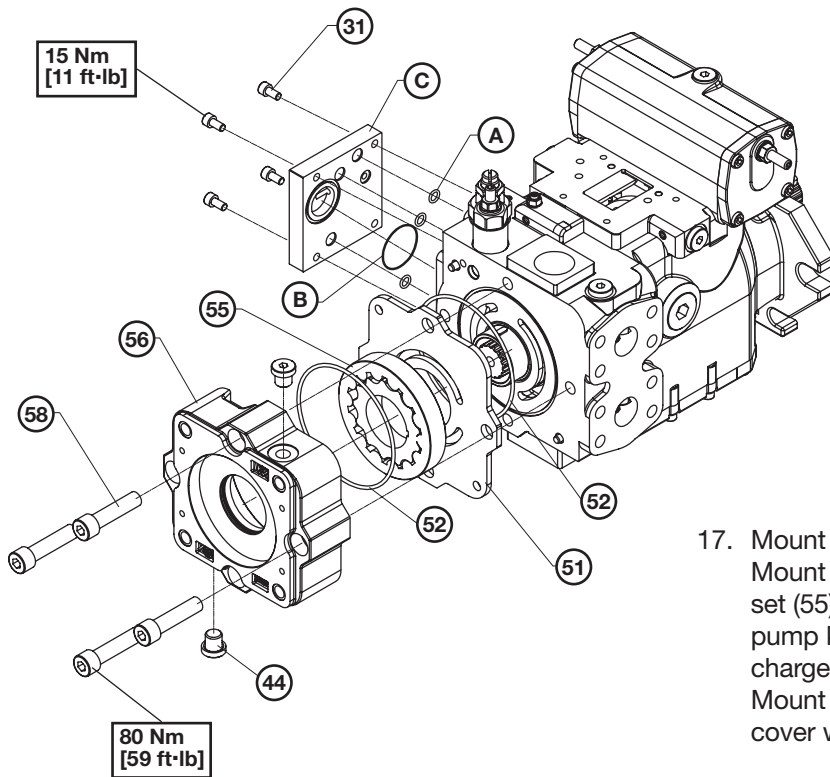

17. Mount O-ring (52) into its groove in pump casing. Mount spacer (51). Mount O-ring (52) and gerotor set (55) on charge pump casing (56). Mount charge pump kit and screws (58) on pump casing – see charge pump mounting position on following page. Mount O-rings (A) and (B) on cover (C). Mount cover with screws (31).

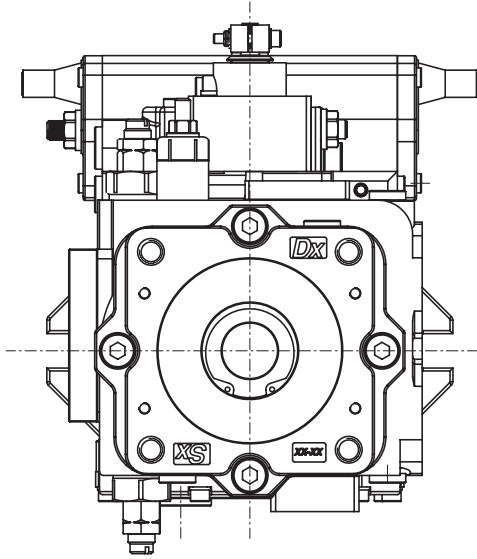

CW Pump (note the DX mark position)

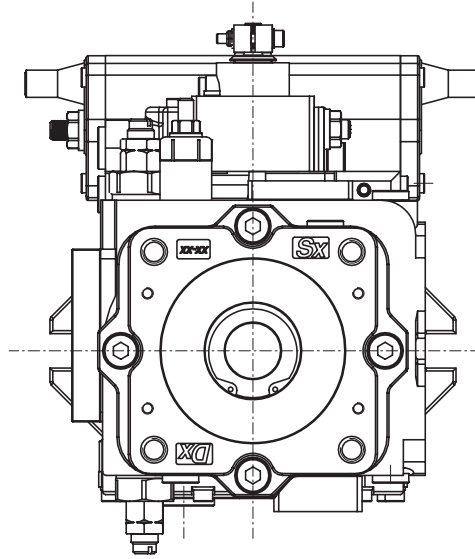

C-CW Pump (note the DX mark position)

18. Charge pump mounting position.

19. Mount O-ring (Z) into its groove in cover (Y) and place cover on charge pump casing. Mount cover (X) and screws (W) and torque them (see torque values).

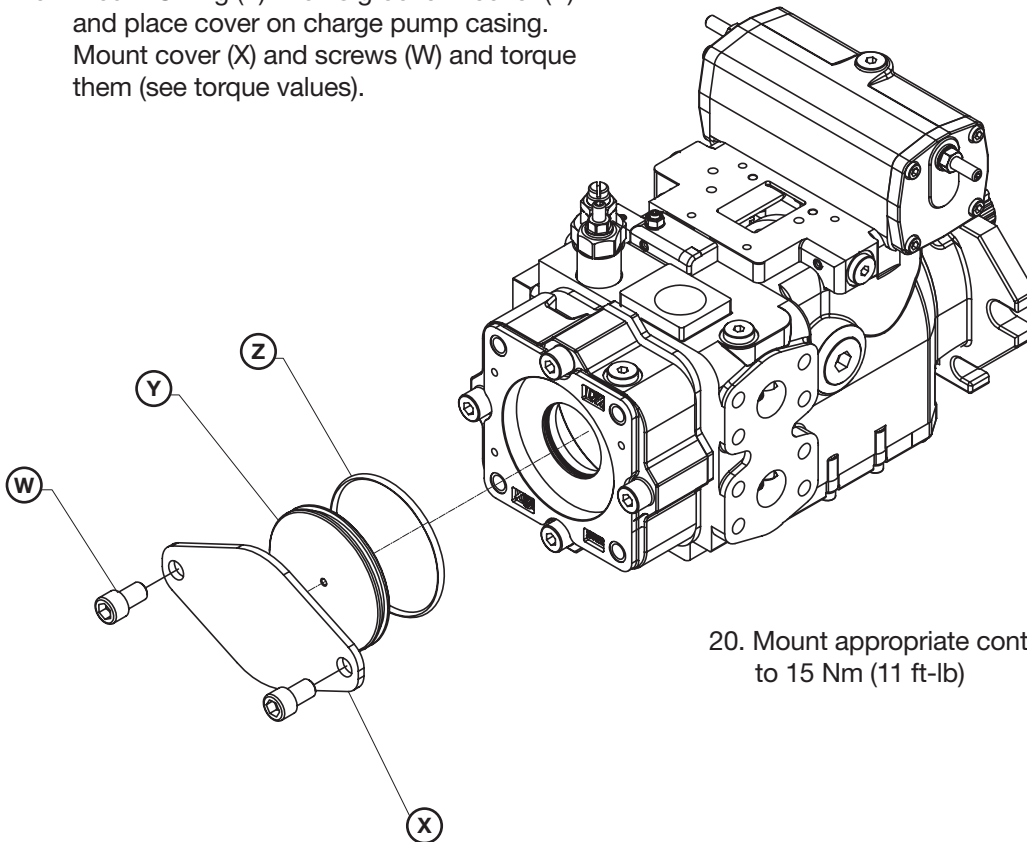

20. Mount appropriate control and torque bolts to 15 Nm (11 ft-lb)

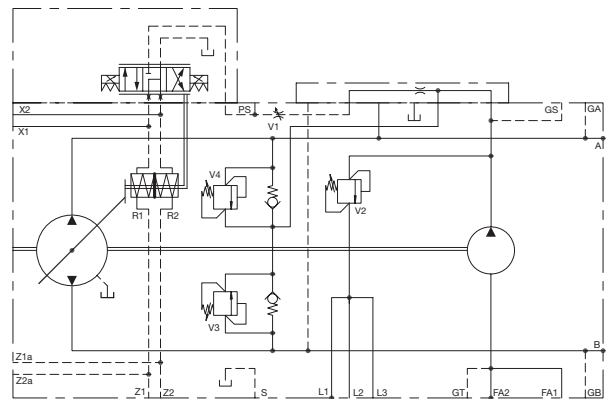
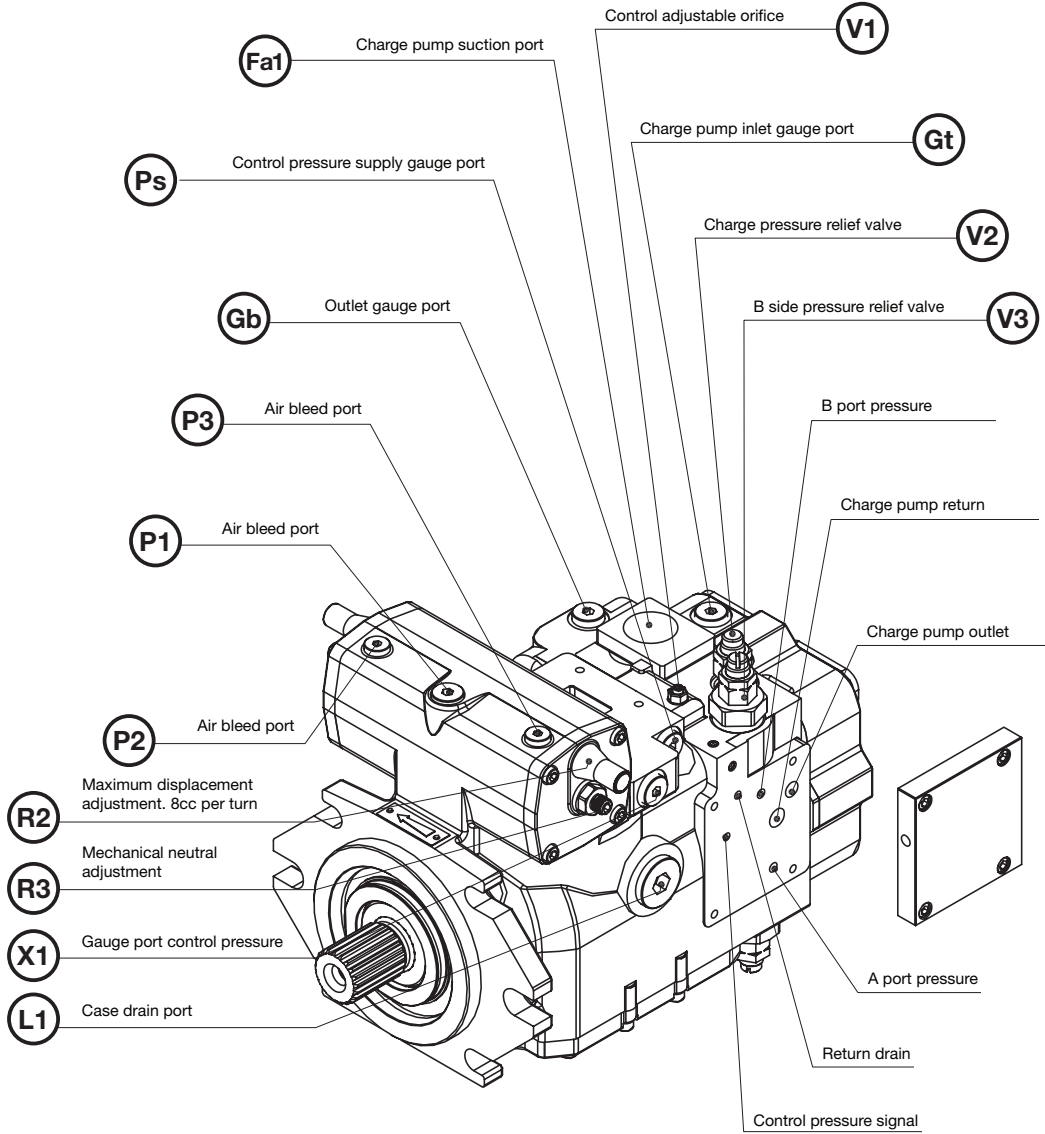

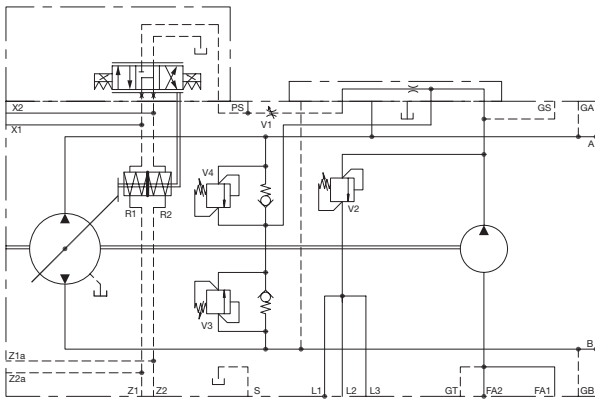
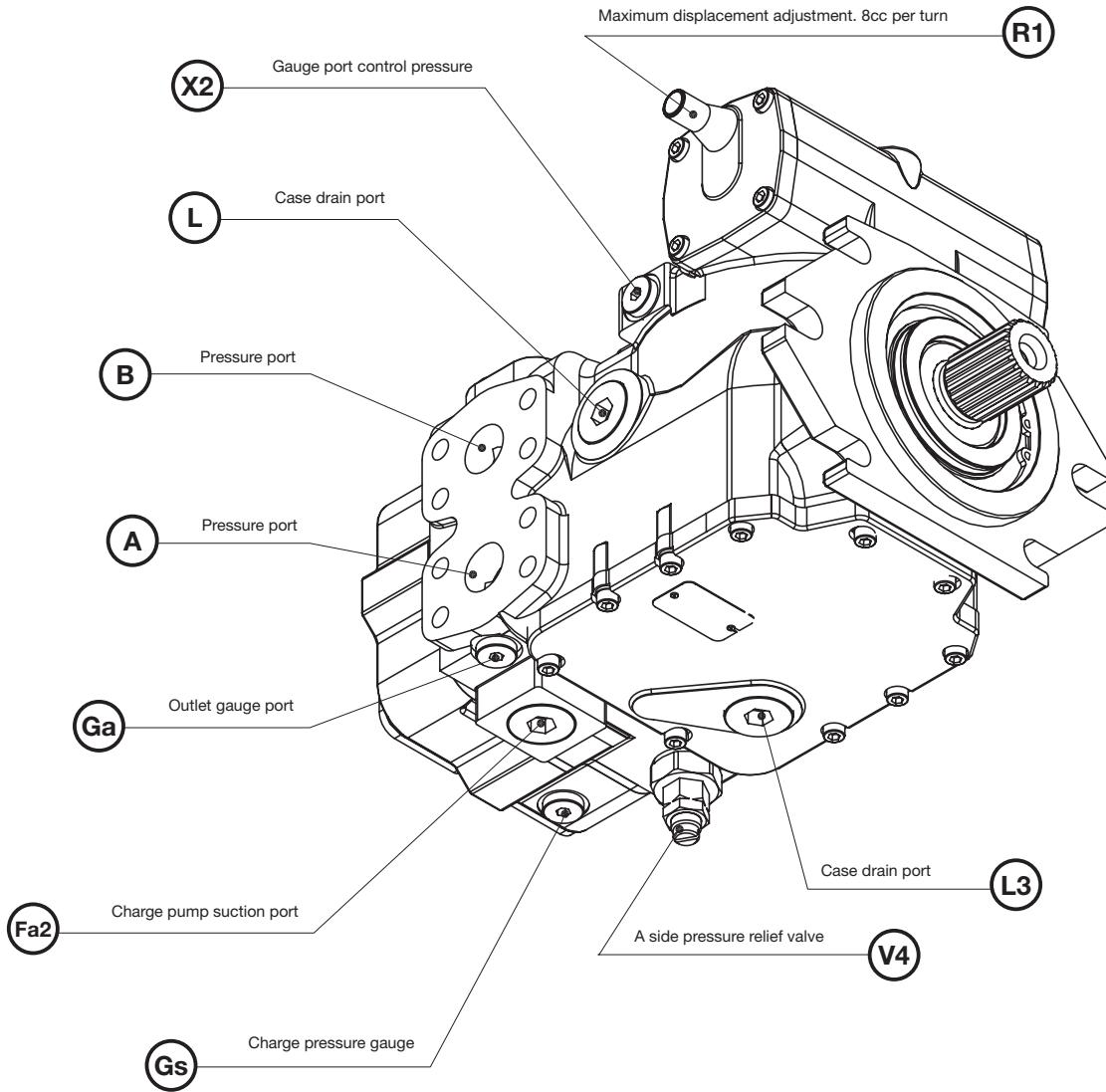

Suggested Gauges

P1 & P2 = 0-25 bar (0-365 PSI)
GS = 0-60 bar (0-870 PSI)
GA & GB = 0-600 bar (0-8700 PSI)

Setting Charge Pressure Relief Valve (V2)

Insert 60 bar (870 PSI) pressure gauge into port GS. Check to ensure test stand and pump rotations are correct and bring prime mover up to 1000 RPM, run until oil temperatures are greater than 68°C (20°F). Loosen charge relief lock nut and adjust CW to increase pressure or CCW to reduce pressure. Once completed, torque nut to 40 N-m (29 ft-lb).

Setting Mechanical Pressure Override (override option P)

Insert gauges into Ports GA, GB. Ensure test stand and pump rotations are correct and bring unit up to operating speed.

Loosen POR valve lock nut and operate control to 30-40% of maximum flow. Slowly increase load until POR valve activates. Adjust POR valve adjustment CW to increase setting and CCW to reduce setting. Tighten lock nut to 40 N-m (29 ft-lb). Reduce load to ensure pump flow is returned to the circuit and then increase load until POR activates and ensure setting has not changed. Run for 10-15 seconds to ensure no pressure oscillations are occurring when the POR is active. Repeat test in opposite flow directions to ensure setting is unchanged.

Centering of the Pump Servo Piston

Insert gauges into Ports GA, GB and block ports A and B. Ensure test stand and pump rotations are correct and bring unit up to operating speed.

Loosen lock nut and screw variable control orifice V1 closed (do not over tighten!) to cut off oil supply to pump displacement control. Remove plug from port PS to ensure no pressure is being delivered to the controller. Loosen the lock nut on R3 and adjust the screw while observing the gauges in Port GA and GB. Stop turning the adjustment when pressure starts to raise in GA or GB, then reverse the direction of the adjustment until pressure in GA and GB are the same. Note the position of the adjustment.

Continue adjusting R3 in opposite direction until pressure increases in opposite gauge. Turn adjustment back until pressure is the same in both ports. Note this position.

With both positions noted, turn the adjustment to a position halfway between the two positions and tighten the R3 lock nut to 40 N-m (29 ft-lb).

Adjust variable control orifice back open and tighten lock nut to 15 N-m (11 ft-lb).

A-B

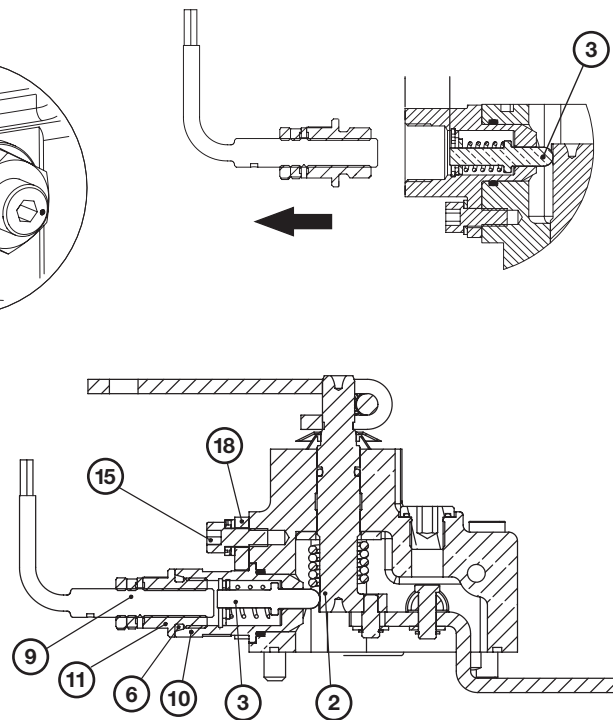
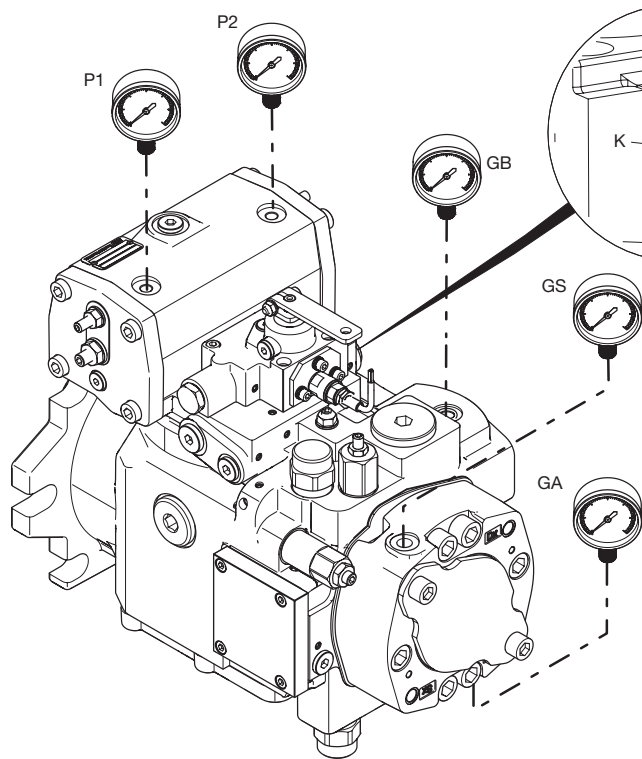

- P1** = Install a pressure gauge 0 ÷ 25 bar (0-365 PSI)
- P2** = Install a pressure gauge 0 ÷ 25 bar (0-365 PSI)
- GS** = Install a pressure gauge 0 ÷ 60 bar (0-870 PSI)
- GA** = Install a pressure gauge 0 ÷ 600 bar (0-8700 PSI)
- GB** = Install a pressure gauge 0 ÷ 600 bar (0-8700 PSI)
- K** = Setting screw for zero setting

Hydraulic Zero-Setting of the Controls A-B

Plug the pressure gauges P1-P2 and check the pressure on the servopiston sides: max Δp accepted = 1 bar (14.5 PSI). Set this value within this range adjusting the screw (K). At the rotation speed of normal use, swivel the pump to maximum displacement, via the control lever, then suddenly release the lever: the pump must swivel back to zero flow within 2 seconds. Repeat the procedure for both flow directions: there must be no significant difference between the two flow directions (equal pressure on GA and GB, max. 2-3 bar differential) (30-40 PSI). If this should occur, act on the control hydraulic zero-setting screw (K) unblocking the screw for eccentric fixing, turning them in order to restore the control zero-setting, until the proper control operation is achieved.

Check the control operation repeating procedure as described above in both the flow directions. The pump must always restore the zero flow position.

Only For B Control, After the Mechanical and Hydraulic Zero-Setting

1. Remove sensor with its plug to expose piston (3). With the proper tool, (depth gauge) identify the deepest point and place it at the max. depth by rotating the eccentric sleeve (10).
2. Hold the sleeve (10) into the above position with the screws (15), but don't tighten them. Assembly sensor seat (11) with the O-Ring (6) on sleeve (10). Screw sensor (9) until is in contact with piston (3). Do not force it. Unscrew sensor (9) 1 and a half turns, or until led switches off. When led switches off, unscrew sensor another quarter of turn.
3. Screw nuts M8x1 with torque 5 Nm (3.5 ft-lb).
4. Be sure that the sleeve (10) can turn to be adjusted. If not, unscrew without removing the screws (15).
5. Move the lever (2) in both directions and check the right behavior of the device. If the setting is not correct, repeat from point 2.
6. Once the setting has been proved correct, tighten the screws (15) with 6 Nm torque (4.5 ft-lb).

C

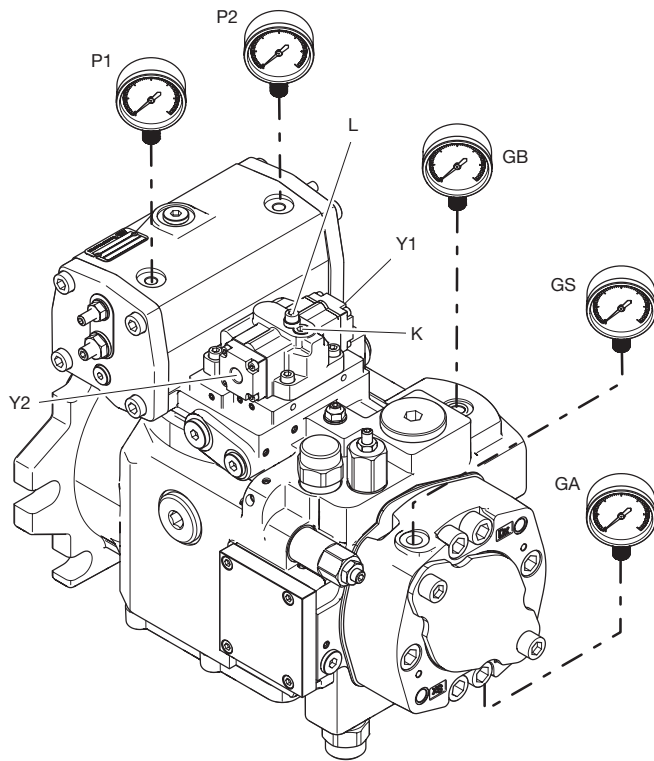

F

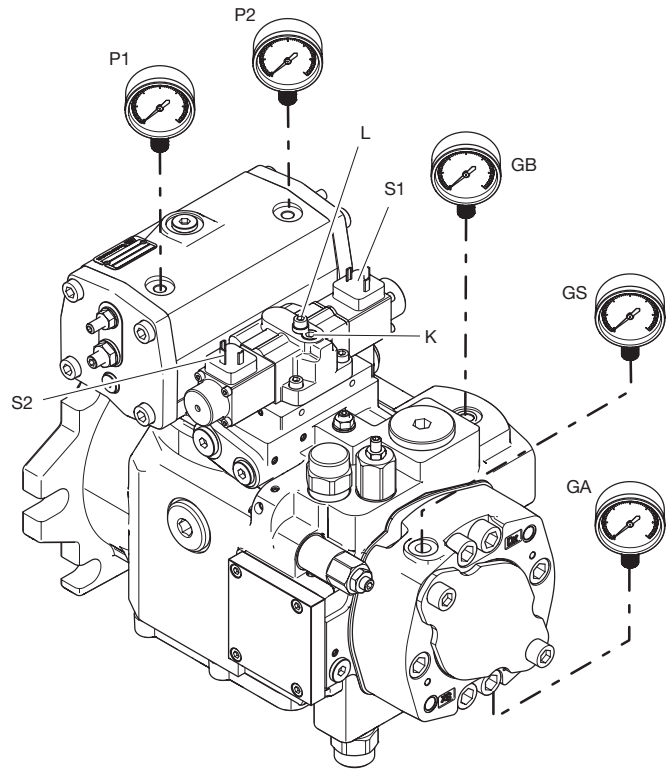

- P1** = Install a pressure gauge 0 ÷ 25 bar (0-365 PSI)
- P2** = Install a pressure gauge 0 ÷ 25 bar (0-365 PSI)
- GS** = Install a pressure gauge 0 ÷ 60 bar (0-870 PSI)
- GA** = Install a pressure gauge 0 ÷ 600 bar (0-8700 PSI)
- GB** = Install a pressure gauge 0 ÷ 600 bar (0-8700 PSI)
- S1/S2** = Input electrical signal
- Y1/Y2** = Hydraulic input signal
- K** = Setting screw for zero setting
- L** = Locking screw of screw "K"

H

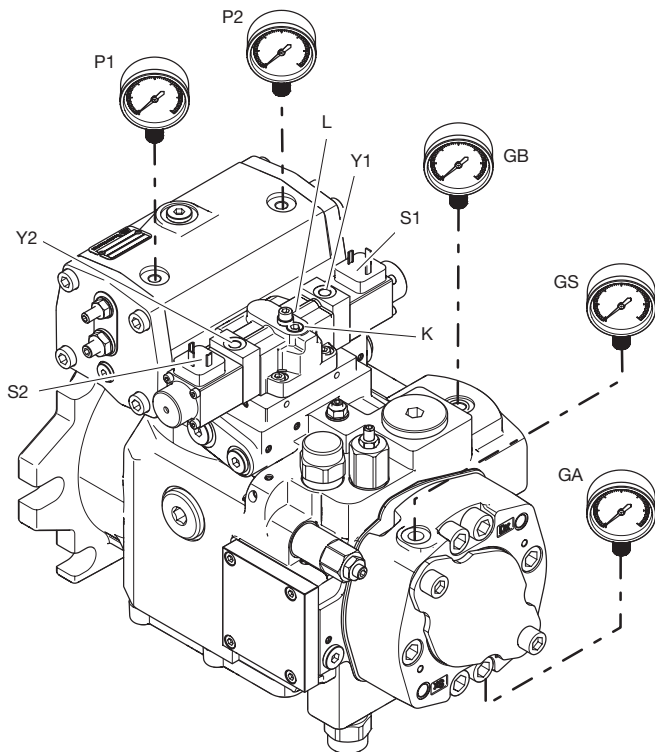

- P1** = Install a pressure gauge 0 ÷ 25 bar (0-365 PSI)
- P2** = Install a pressure gauge 0 ÷ 25 bar (0-365 PSI)
- GS** = Install a pressure gauge 0 ÷ 60 bar (0-870 PSI)
- GA** = Install a pressure gauge 0 ÷ 600 bar (0-8700 PSI)
- GB** = Install a pressure gauge 0 ÷ 600 bar (0-8700 PSI)
- S1/S2** = Input electrical signal
- Y1/Y2** = Hydraulic input signal
- K** = Setting screw for zero setting
- L** = Locking screw of screw “K”

Hydraulic Zero-Setting of the Controls C-F-H

Plug the pressure gauges P1-P2 and check the pressure on the servopiston: max Δp accepted = 1 bar. (14.5 PSI) Set this value within this range adjusting the screw (K).

At the rotation speed of normal use, swivel the pump to maximum displacement, via the hydraulic control (C) or electric control (F-H), then suddenly release the said input command: the pump must swivel back to zero flow within 2 second. Repeat the procedure for both flow directions: there must be no significant difference between the two flow directions (equal pressure on GA and GB, max. 2-3 bar differential) (30-45 PSI).

If this should occur, act on the control hydraulic zero-setting screw (K) unblocking the screw (L) for eccentric fixing, turning them in order to restore the control zero-setting, until the proper control operation is achieved.

Check the control operation repeating procedure as described above in both the flow directions. The pump must always restore the zero flow position.

Alternative supply current to the solenoids S1-S2 (or pressure to Y1-Y2): check the current (or pressure) of the control start and the max flow value with and without load. If the parameters do not fall within the expected values, check the hydraulic zero.

D

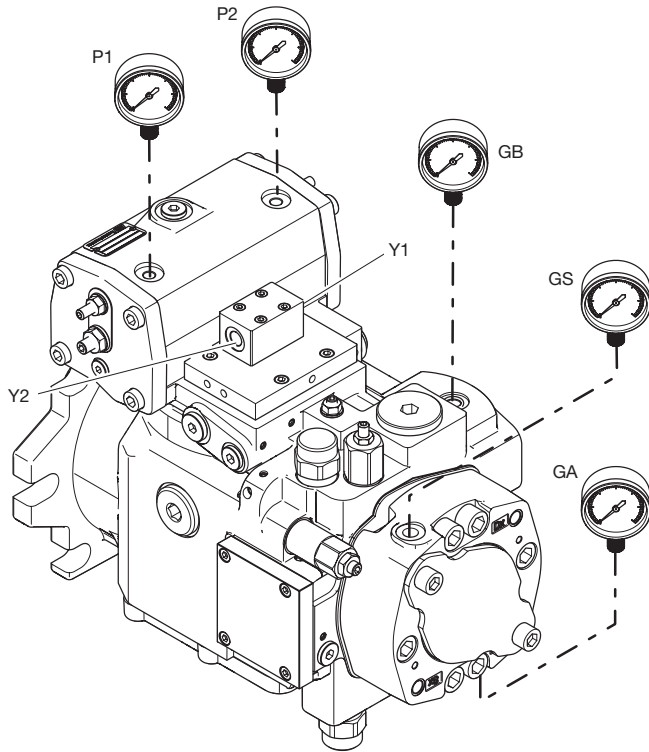

G

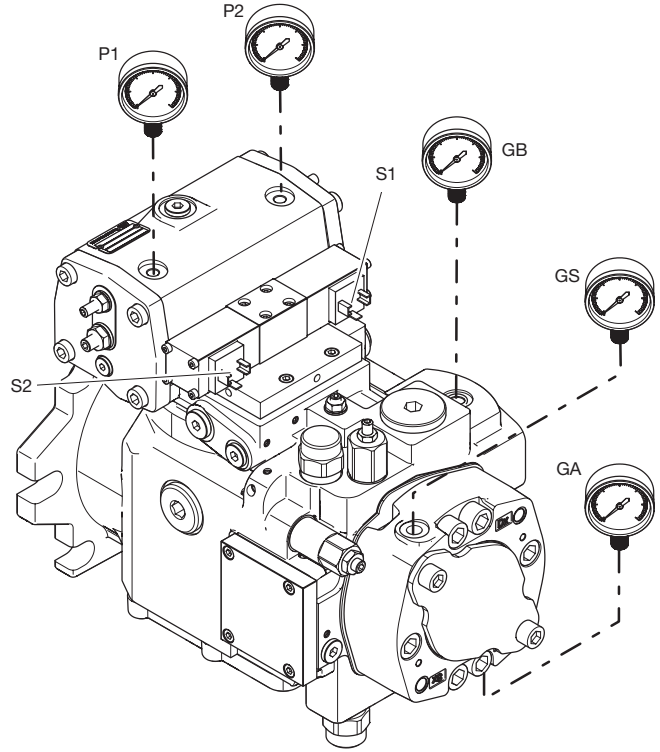

- P1** = Install a pressure gauge 0 ÷ 25 bar (0-365 PSI)
- P2** = Install a pressure gauge 0 ÷ 25 bar (0-365 PSI)
- GS** = Install a pressure gauge 0 ÷ 60 bar (0-870 PSI)
- GA** = Install a pressure gauge 0 ÷ 600 bar (0-8700 PSI)
- GB** = Install a pressure gauge 0 ÷ 600 bar (0-8700 PSI)
- S1/S2** = Input electrical signal
- Y1/Y2** = Hydraulic input signal
- K** = Setting screw for zero setting
- L** = Locking screw of screw "K"

Check for Correct Operation Controls D-G-E

Feed voltage/current to solenoids S1-S2 (or feed pressure to Y1-Y2) to check the current (or pressure) of the control start and the max flow with and without load. If the parameters do not fall within the expected values the control or the pump must be checked for damage or wear.

E

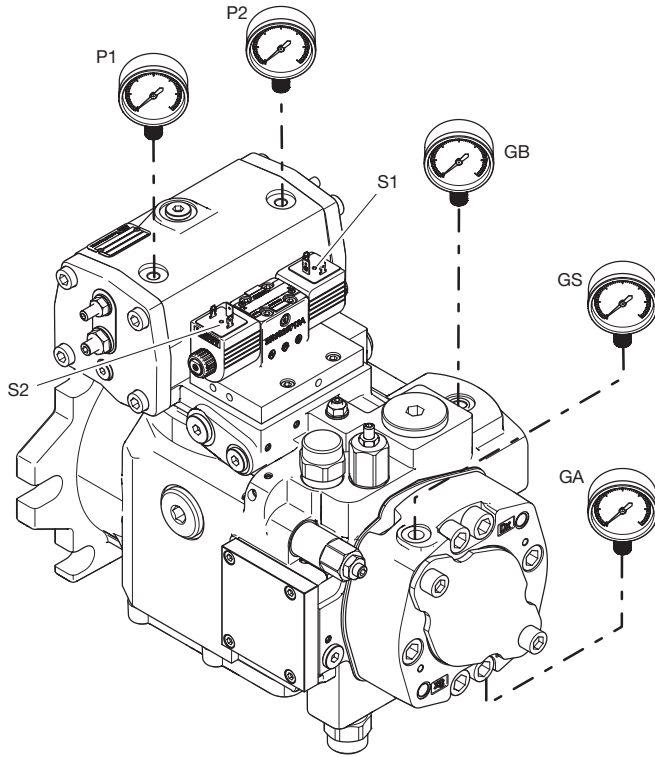

- P1** = Install a pressure gauge 0 ÷ 25 bar (0-365 PSI)
- P2** = Install a pressure gauge 0 ÷ 25 bar (0-365 PSI)
- GS** = Install a pressure gauge 0 ÷ 60 bar (0-870 PSI)
- GA** = Install a pressure gauge 0 ÷ 600 bar (0-8700 PSI)
- GB** = Install a pressure gauge 0 ÷ 600 bar (0-8700 PSI)
- S1/S2** = Input electrical signal
- Y1/Y2** = Hydraulic input signal
- K** = Setting screw for zero setting
- L** = Locking screw of screw “K”

Alternately activate solenoids S1-S2 to check proper functioning of the “ON-OFF” control

J/K

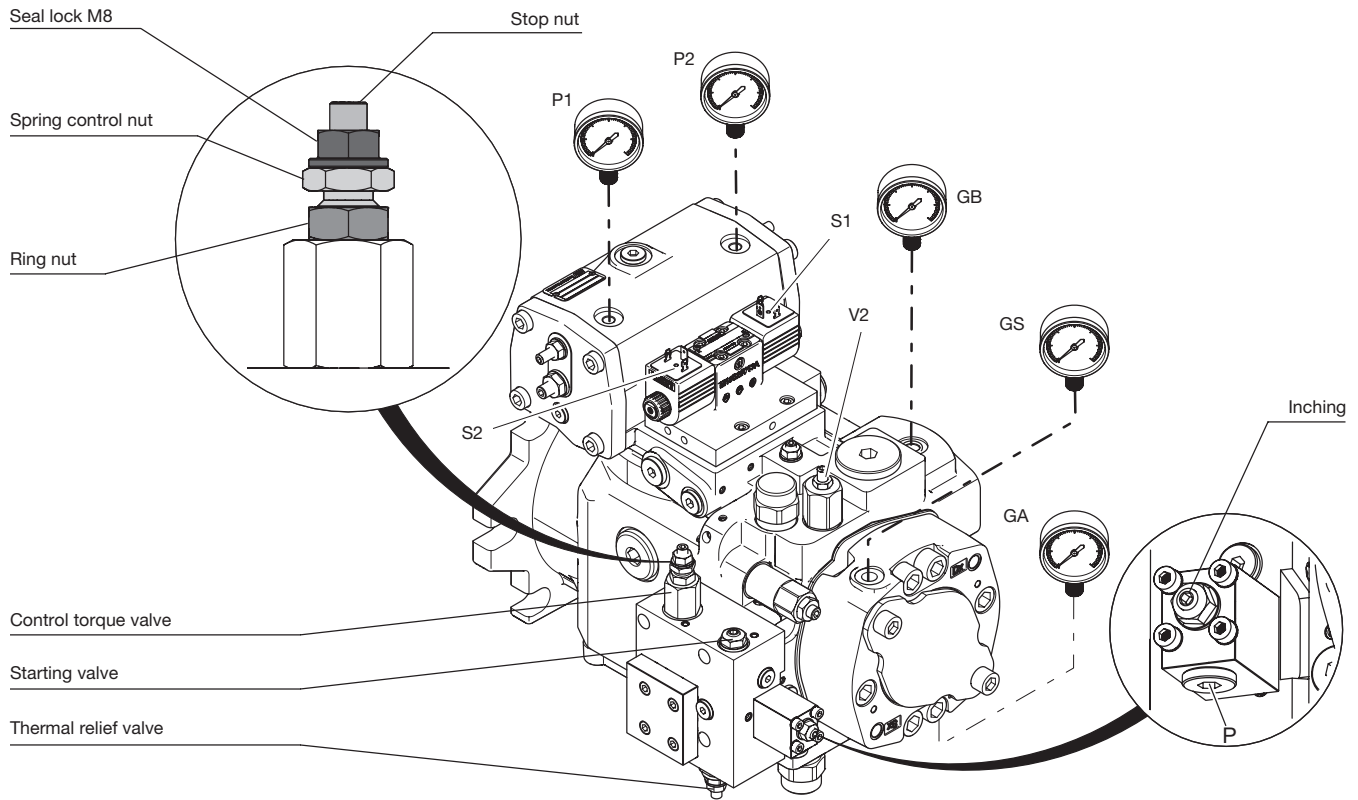

- P1** = Install a pressure gauge 0 ÷ 25 bar (0-365 PSI)
- P2** = Install a pressure gauge 0 ÷ 25 bar (0-365 PSI)
- GS** = Install a pressure gauge 0 ÷ 60 bar (0-870 PSI)
- GA** = Install a pressure gauge 0 ÷ 600 bar (0-8700 PSI)
- GB** = Install a pressure gauge 0 ÷ 600 bar (0-8700 PSI)
- V2** = Adjusting the boost pressure
- S1/S2** = Input electrical signal
- Y1/Y2** = Hydraulic input signal

Introduction

This procedure requires that the control is mounted on the pump and the pump is installed in the machine or in the Test Rig.

Setting Instructions Automotive Controls

To test Automotive Control. Set engine speed to 1000 RPM. Unscrew nut on starting valve – screw clockwise the starting valve screw fully in.

Set charge pressure relief valve to 22 bar (320 PSI).

Unscrew nut on inching valve. Screw clockwise the setting screw fully in, then adjust it out (counter-clockwise), one and a half turn.

Lock the nut of inching valve to 25 Nm Torque (18 ft-lb).

Unscrew nut on thermal relief valve and clockwise turn its setting screw fully in. Lock the nut of thermal relief valve to 25 Nm Torque.

Unscrew the ring nut and the stop nut (loose seal lock M8) on torque valve. Screw clockwise control nut fully in, and then screw clockwise stop nut adjuster fully in (be careful not to over-torque it).

Run the pump at the required starting speed request. Supplying one of the input signals of the automotive control.

Unscrew (counter-clockwise) the starting valve adjuster until the pump starts to go into stroke (no more than 8-10 l/min [2.25 GPM]).

Then lock the starting valve nut to 25 Nm torque (18 ft-lb).

Verify how many RPM are needed to reach full pump stroke (400 – 550 RPM).

Keep pump's RPM constant at maximum torque setting value. On torque valve, unscrew the stop nut adjuster 4 turns and lock seal-lock M8 nut to 25 Nm torque (18 ft-lb).

Increase working pressure until the pump reaches torque setting.

Unscrew control nut until pump flow starts to decrease, do not move stop nut adjuster. Screw ring nut to 20 Nm torque (15 ft-lb).

Verify pump's torque curve changing the working pressure. If pump displacement decreases too quickly, loosen seal lock of stop nut and screw (clockwise) in, if necessary. Then lock the seal lock of stop nut to 25 Nm torque (18 ft-lb).

Inching Check (Pump at Max Speed and in FW Or REV)

- **Mechanical Inching:** verify that rotating the lever to full stroke, the pump flow goes to zero.
- **Hydraulic Inching:** verify that putting 15 bar (218 PSI) on inching port the flow goes to zero.

Control Setting Values

Control Setting Values							
			Opening Screw Restrictor (V1) (Turns)	Minimum Value Of Piloting Pressure On Starting	Maximum Value Of Piloting Pressure On Starting	Minimum Value Of Piloting Pressure On Finish	Maximum Value Of Piloting Pressure On Finish
A	Manual lever control with feedback	-	1	-	-	-	-
B	Manual lever with feedback with neutral position micro switch	-	1	-	-	-	-
C	Hydraulic proportional with feedback	(*)	1	5 bar	7 bar	16 bar	19.5 bar
D	Hydraulic proportional without feedback	(*)	-	5 bar	7 bar	12 bar	15 bar
F	Electric proportional with feedback	24V (*)	1	180 mA	240 mA	540 mA	660 mA
		12V (*)	1	360 mA	460 mA	1080 mA	1320 mA
G	Electric proportional without feedback	24V (*)	1	235 mA	365 mA	585 mA	715 mA
		12V (*)	1	470 mA	730 mA	1170 mA	1430 mA
E	Electric on/off		1	-	-	-	-
H	Electric proportional with feedback, with hydraulic emergency override	24V (**)	1	180 mA	240 mA	540 mA	660 mA
		12V (**)	1	360 mA	460 mA	1080 mA	1320 mA
*Max case pressure: 1 bar							
**Testing functionality hydraulic emergency							

Troubleshooting Matrix	
Symptom	Possible causes
Pump not operating in either direction	Low fluid level in reservoir
	Charge pump suction line plugged or disconnected
	Cross port relief damaged
	Wrong input rotation
	Command to pump control may be faulty
	Damaged actuator
Symptom	Possible Causes
Pump operates sluggish or generates erratic movement	Low fluid level in reservoir
	Charge pump suction line restricted
	Improper charge pressure, check charge relief
	Command to pump control may be faulty
	Damaged actuator
Symptom	Possible Causes
Transmission operating hot	Heat exchanger improperly sized
	Heat exchanger damaged/plugged
	Excessive operation over cross port reliefs
	Cross port relief damaged
	Actuator damaged/bypassing fluid
	Low fluid level in reservoir
Symptom	Possible Causes
Excessive noise from system	Improper shaft alignment
	Charge pump suction line restricted/cavitation of charge pump
	Low fluid level in reservoir
	Aeration of hydraulic fluid in tank
Symptom	Possible Causes
Leakage from shaft seal	Case drain pressure too high
	Seal damaged
Symptom	Possible Causes
High case drain pressure	Drain hose improperly sized
	Drain hose restricted or blocked
Symptom	Possible Causes
Slow actuator speed	Prime mover RPM is slow
	Improper charge pressure, check charge relief
	Charge pump suction line restricted
	Oil temperature too high
Symptom	Possible Causes
Low actuator output force	Cross port relief damaged
	Cross port relief improperly set
	Actuator damaged
	Oil temperature too high

When diagnosing, it is suggested that you have two 8700 PSI (600 bar) pressure gauges (system pressure), a 870 PSI (60 bar) pressure gauge (charge pressure), a vacuum gauge (charge inlet), tachometer (engine RPM), amp meter (electric motor current draw), and temperature gun (to measure system temperatures).

The items described in this document and other documents and descriptions provided by Parker Hannifin Corporation, its subsidiaries and its authorized distributors ("Seller") are hereby offered for sale at prices to be established by Seller. This offer and its acceptance by any customer ("Buyer") shall be governed by all of the following Terms and Conditions. Buyer's order for any item described in its document, when communicated to Seller verbally, or in writing, shall constitute acceptance of this offer. All goods, services or work described will be referred to as "Products".

1. **Terms and Conditions.** Seller's willingness to offer Products, or accept an order for Products, to or from Buyer is subject to these Terms and Conditions or any newer version of the terms and conditions found on-line at www.parker.com/sale/terms/. Seller objects to any contrary or additional terms or conditions of Buyer's order or any other document issued by Buyer.
2. **Price Adjustments; Payments.** Prices stated on Seller's quote or other documentation offered by Seller are valid for 30 days, and do not include any sales, use, or other taxes unless specifically stated. Unless otherwise specified by Seller, all prices are F.C.A. Seller's facility (INCOTERMS 2010). Payment is subject to credit approval and is due 30 days from the date of invoice or such other term as required by Seller's Credit Department, after which Buyer shall pay interest on any unpaid invoices at the rate of 1.5% per month or the maximum allowable rate under applicable law.
3. **Delivery Dates; Title and Risk; Shipment.** All delivery dates are approximate and Seller shall not be responsible for any damages resulting from any delay. Regardless of the manner of shipment, title to any products and risk of loss or damage shall pass to Buyer upon placement of the products with the shipment carrier at Seller's facility. Unless otherwise stated, Seller may exercise its judgment in choosing the carrier and means of delivery. No deferment of shipment at Buyers' request beyond the respective dates indicated will be made except on terms that will indemnify, defend and hold Seller harmless against all loss and additional expense. Buyer shall be responsible for any additional shipping charges incurred by Seller due to Buyer's acts or omissions.
4. **Warranty.** Seller warrants that the Products sold hereunder shall be free from defects in material or workmanship for a period of eighteen months from the date of shipment from the Company. The prices charged for Seller's products are based upon the exclusive limited warranty stated above, and upon the following disclaimer: **DISCLAIMER OF WARRANTY: THIS WARRANTY COMPRISES THE SOLE AND ENTIRE WARRANTY PERTAINING TO PRODUCTS PROVIDED HEREUNDER. SELLER DISCLAIMS ALL OTHER WARRANTIES, EXPRESS AND IMPLIED, INCLUDING DESIGN, MERCHANTABILITY AND FITNESS FOR A PARTICULAR PURPOSE.**
5. **Claims; Commencement of Actions.** Buyer shall promptly inspect all Products upon delivery. No claims for shortages will be allowed unless reported to the Seller within 10 days of delivery. No other claims against Seller will be allowed unless asserted in writing within 30 days after delivery. Buyer shall notify Seller of any alleged breach of warranty within 30 days after the date the defect is or should have been discovered by Buyer. Any action based upon breach of this agreement or upon any other claim arising out of this sale (other than an action by Seller for an amount due on any invoice) must be commenced within 12 months from the date of the breach without regard to the date breach is discovered.
6. **LIMITATION OF LIABILITY. UPON NOTIFICATION, SELLER WILL, AT ITS OPTION, REPAIR OR REPLACE A DEFECTIVE PRODUCT, OR REFUND THE PURCHASE PRICE. IN NO EVENT SHALL SELLER BE LIABLE TO BUYER FOR ANY SPECIAL, INDIRECT, INCIDENTAL OR CONSEQUENTIAL DAMAGES ARISING OUT OF, OR AS THE RESULT OF, THE SALE, DELIVERY, NON-DELIVERY, SERVICING, USE OR LOSS OF USE OF THE PRODUCTS OR ANY PART THEREOF, OR FOR ANY CHARGES OR EXPENSES OF ANY NATURE INCURRED WITHOUT SELLER'S WRITTEN CONSENT, EVEN IF SELLER HAS BEEN NEGLIGENT, WHETHER IN CONTRACT, TORT OR OTHER LEGAL THEORY. IN NO EVENT SHALL SELLER'S LIABILITY UNDER ANY CLAIM MADE BY BUYER EXCEED THE PURCHASE PRICE OF THE PRODUCTS.**
7. **User Responsibility.** The user, through its own analysis and testing, is solely responsible for making the final selection of the system and Product and assuring that all performance, endurance, maintenance, safety and warning requirements of the application are met. The user must analyze all aspects of the application and follow applicable industry standards and Product information. If Seller provides Product or system options, the user is responsible for determining that such data and specifications are suitable and sufficient for all applications and reasonably foreseeable uses of the Products or systems.
8. **Loss to Buyer's Property.** Any designs, tools, patterns, materials, drawings, confidential information or equipment furnished by Buyer or any other items which become Buyer's property, will be considered obsolete and may be destroyed by Seller after two consecutive years have elapsed without Buyer ordering the items manufactured using such property. Seller shall not be responsible for any loss or damage to such property while it is in Seller's possession or control.
9. **Special Tooling.** A tooling charge may be imposed for any special tooling, including without limitation, dies, fixtures, molds and patterns, acquired to manufacture Products. Such special tooling shall be and remain Seller's property notwithstanding payment of any charges by Buyer. In no event will Buyer acquire any interest in apparatus belonging to Seller which is utilized in the manufacture of the Products, even if such apparatus has been specially converted or adapted for such manufacture and notwithstanding any charges paid by Buyer. Unless otherwise agreed, Seller shall have the right to alter, discard or otherwise dispose of any special tooling or other property in its sole discretion at any time.
10. **Buyer's Obligation; Rights of Seller.** To secure payment of all sums due or otherwise, Seller shall retain a security interest in the goods delivered and this agreement shall be deemed a Security Agreement under the Uniform Commercial Code. Buyer authorizes Seller as its attorney to execute and file on Buyer's behalf all documents Seller deems necessary to perfect its security interest.
11. **Improper use and Indemnity.** Buyer shall indemnify, defend, and hold Seller harmless from any claim, liability, damages, lawsuits, and costs (including

- attorney fees), whether for personal injury, property damage, patent, trademark or copyright infringement or any other claim, brought by or incurred by Buyer, Buyer's employees, or any other person, arising out of: (a) improper selection, improper application or other misuse of Products purchased by Buyer from Seller; (b) any act or omission, negligent or otherwise, of Buyer; (c) Seller's use of patterns, plans, drawings, or specifications furnished by Buyer to manufacture Product; or (d) Buyer's failure to comply with these terms and conditions. Seller shall not indemnify Buyer under any circumstance except as otherwise provided.
12. **Cancellations and Changes.** Orders shall not be subject to cancellation or change by Buyer for any reason, except with Seller's written consent and upon terms that will indemnify, defend and hold Seller harmless against all direct, incidental and consequential loss or damage. Seller may change product features, specifications, designs and availability with notice to Buyer.
13. **Limitation on Assignment.** Buyer may not assign its rights or obligations under this agreement without the prior written consent of Seller.
14. **Force Majeure.** Seller does not assume the risk and shall not be liable for delay or failure to perform any of Seller's obligations by reason of circumstances beyond the reasonable control of Seller (hereinafter "Events of Force Majeure"). Events of Force Majeure shall include without limitation: accidents, strikes or labor disputes, acts of any government or government agency, acts of nature, delays or failures in delivery from carriers or suppliers, shortages of materials, or any other cause beyond Seller's reasonable control.
15. **Waiver and Severability.** Failure to enforce any provision of this agreement will not waive that provision nor will any such failure prejudice Seller's right to enforce that provision in the future. Invalidation of any provision of this agreement by legislation or other rule of law shall not invalidate any other provision herein. The remaining provisions of this agreement will remain in full force and effect.
16. **Termination.** Seller may terminate this agreement for any reason and at any time by giving Buyer thirty (30) days written notice of termination. Seller may immediately terminate this agreement, in writing, if Buyer: (a) commits a breach of any provision of this agreement (b) appoints a trustee, receiver or custodian for all or any part of Buyer's property (c) files a petition for relief in bankruptcy on its own behalf, or by a third party (d) makes an assignment for the benefit of creditors, or (e) dissolves or liquidates all or a majority of its assets.
17. **Governing Law.** This agreement and the sale and delivery of all Products hereunder shall be deemed to have taken place in and shall be governed and construed in accordance with the laws of the State of Ohio, as applicable to contracts executed and wholly performed therein and without regard to conflicts of laws principles. Buyer irrevocably agrees and consents to the exclusive jurisdiction and venue of the courts of Cuyahoga County, Ohio with respect to any dispute, controversy or claim arising out of or relating to this agreement.
18. **Indemnity for Infringement of Intellectual Property Rights.** Seller shall have no liability for infringement of any patents, trademarks, copyrights, trade dress, trade secrets or similar rights except as provided in this Section. Seller will defend and indemnify Buyer against allegations of infringement of U.S. patents, U.S. trademarks, copyrights, trade dress and trade secrets ("Intellectual Property Rights"). Seller will defend at its expense and will pay the cost of any settlement or damages awarded in an action brought against Buyer based on an allegation that a Product sold pursuant to this Agreement infringes the Intellectual Property Rights of a third party. Seller's obligation to defend and indemnify Buyer is contingent on Buyer notifying Seller within ten (10) days after Buyer becomes aware of such allegations of infringement, and Seller having sole control over the defense of any allegations or actions including all negotiations for settlement or compromise. If a Product is subject to a claim that it infringes the Intellectual Property Rights of a third party, Seller may, at its sole expense and option, procure for Buyer the right to continue using the Product, replace or modify the Product so as to make it noninfringing, or offer to accept return of the Product and return the purchase price less a reasonable allowance for depreciation. Notwithstanding the foregoing, Seller shall have no liability for claims of infringement based on information provided by Buyer, or directed to Products delivered hereunder for which the designs are specified in whole or part by Buyer, or infringements resulting from the modification, combination or use in a system of any Product sold hereunder. The foregoing provisions of this Section shall constitute Seller's sole and exclusive liability and Buyer's sole and exclusive remedy for infringement of Intellectual Property Rights.
19. **Entire Agreement.** This agreement contains the entire agreement between the Buyer and Seller and constitutes the final, complete and exclusive expression of the terms of sale. All prior or contemporaneous written or oral agreements or negotiations with respect to the subject matter are herein merged.
20. **Compliance with Law, U. K. Bribery Act and U.S. Foreign Corrupt Practices Act.** Buyer agrees to comply with all applicable laws and regulations, including both those of the United Kingdom and the United States of America, and of the country or countries of the Territory in which Buyer may operate, including without limitation the U. K. Bribery Act, the U.S. Foreign Corrupt Practices Act ("FCPA") and the U.S. Anti-Kickback Act (the "Anti-Kickback Act"), and agrees to indemnify and hold harmless Seller from the consequences of any violation of such provisions by Buyer, its employees or agents. Buyer acknowledges that they are familiar with the provisions of the U. K. Bribery Act, the FCPA and the Anti-Kickback Act, and certifies that Buyer will adhere to the requirements thereof. In particular, Buyer represents and agrees that Buyer shall not make any payment or give anything of value, directly or indirectly to any governmental official, any foreign political party or official thereof, any candidate for foreign political office, or any commercial entity or person, for the purpose of influencing such person to purchase products or otherwise benefit the business of Seller. 04/2014



January 2017 Revisions:

Updated model code, miscellaneous typo errors corrected,
updated controller kits for Series II control, corrected charge
pump tolerance.

Parker Hannifin Corporation
Hydraulic Pump and Power Systems Division
14249 Industrial Pkwy.
Marysville, OH 43040
phone 937 644 3915
fax 937 642 3738
www.parker.com/hps

