

# DENISON HYDRAULICS

## controls for goldcup pumps & motors series 6. . .30

### service information

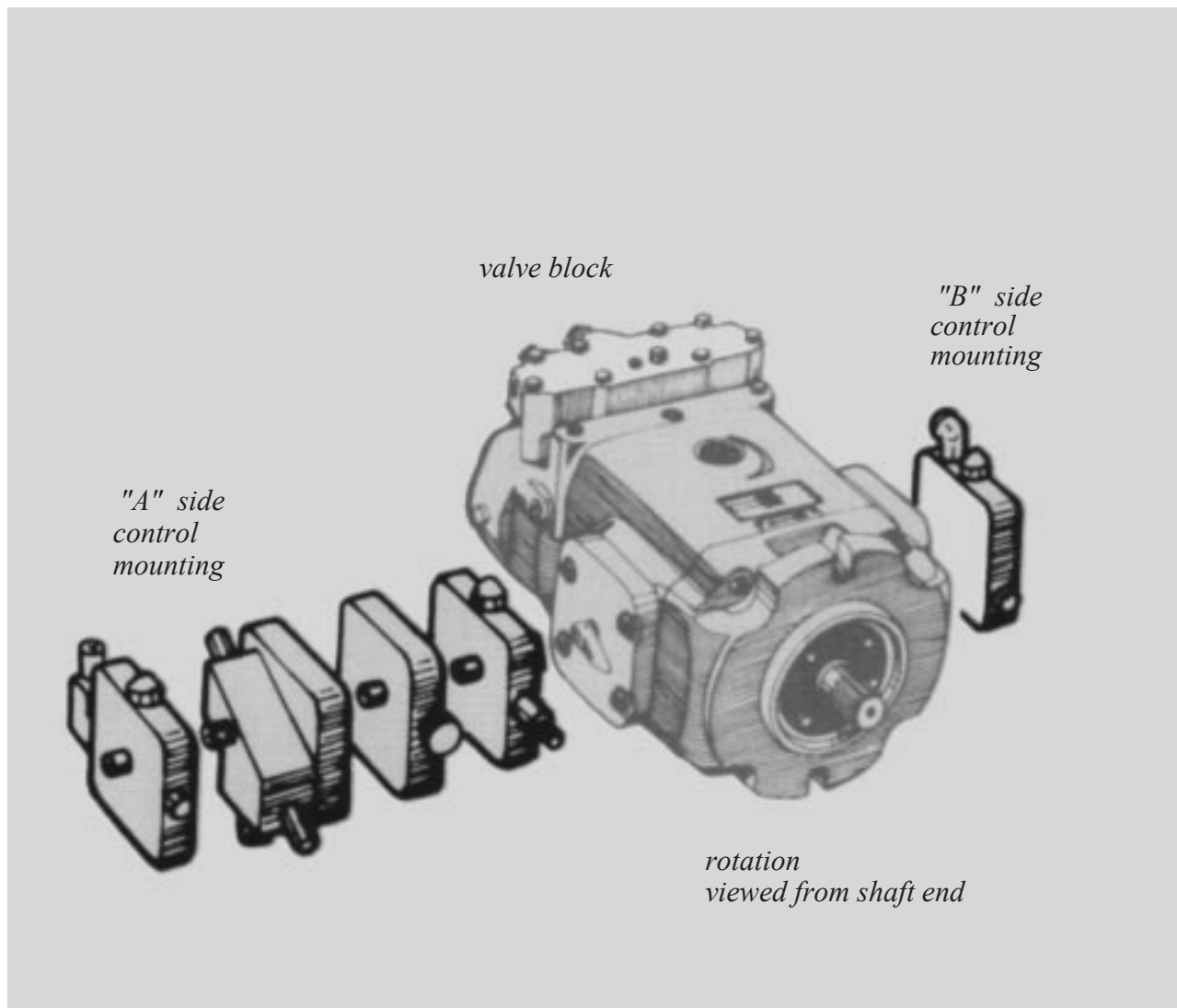

Publ. S1-AM030-A replaces S1-AM030

Revised 4/02

**DENISON** | **Hydraulics**



	DESCRIPTION	PAGE
Ordering Code	Pump Controls_____	4
	Motor Controls_____	4
Table 1	Typical Characteristics_____	5
Code 1	Screw Adjustment Control. Disassy/Assy/Test_____	7
	Figure 1 Screw Adjustment Control_____	9
Code 2A	Cylinder Control, Disassy/Assy/Test_____	10
	Figure 2A Cylinder Control_____	13
Code 2H	Position Cylinder Control. Disassy/Assy/Test_____	14
	Figure 2H 3 Position Cylinder Control_____	17
	Code 40/4A	R
	Rotary Servo, Spring Ctd/Trimmer. Disassy/Assy/Test_____	18
	Figure 4A Rotary Servo, Spring Ctd/Trimmer_____	21
	Code 4B/4C	R
	Rotary Servo, Brake and Bypass Valve. Disassy/Assy/Test_____	22
	Figure 4C Rotary Servo, Brake and Bypass Valve_____	26
Code 5A	Electric Stroker. Disassy/Assy/Test_____	27
	Figure 5A Electric Stroker_____	31
	Figure 5A-1 Servo for Electric Stroker (Pump)_____	33
	Figure 5A-2 Servo for Electric Stroker (Motor)_____	35
Code 5C	Electric Stroker with Brake & Bypass Valve. Disassy/Assy/Test-_____	36
	Figure 5C Electric Stroker with Brake & Bypass Valve_____	41
	Figure 5C-1 Brake and Bypass Valve for 5C Control-_____	43
Code 60	Hydraulic Stroker. Disassy/Assy/Test_____	44
	Figure 60 Hydraulic Stroker_____	47
	Figure 60-1 Servo for Hydraulic Stroker_____	48
Code 6A	Hydraulic Stroker/Adj. Stops. Disassy/Assy/Test-_____	49
	Figure 6A Hydraulic Stroker/Adj. Stops-_____	53
Code 6B	Hydraulic Stroker with Brake & Bypass Valve. Disassy/Assy/Test_____	54
	Figure 6B Hydraulic Stroker with Brake & Bypass Valve-_____	57
	Figure 6B-1 Brake and Bypass Valve for 600 Series-_____	60
Code 6C	Hydraulic Stroker with Brake & Bypass Valve/Adj. Stops Disassy/Assy/Test_____	61
	Figure 6C Hydraulic Stroker with Brake & Bypass Valve/Adj. Stops_____	64
Code 7*	Feedback for 700 Series HI-IQ Servovalve Control_____	66
	SK-15045 Anti-Backlash Spring Installation for Feedback Controls_____	68
	Figure 7 Feedback for 700 Series HI-IQ Servovalve Control_____	70
Code 8A	Hydraulic Stroker. Disassy/Assy/Test_____	71
	Figure 8A Hydraulic Stroker Control-_____	76
	Figure 8A-1 Hydraulic/Electric Stroker Spool Assemblies-_____	77
Code 8C	Hydraulic Stroker with Brake & Bypass Valve. Disassy/Assy/Test_____	78
	Figure 8C Hydraulic Stroker with Brake & Bypass Valve-_____	84
	Figure 8C-1 Spool Assemblies for 8C & 9C Stroker w/Brake & Bypass Valve-_____	85
	Figure 8C-2 Brake Trimmer for 8C & 9C Stroker w/Brake & Bypass Valve-_____	86
Code 9A	Electric Stroker Control Disassy/Assy/Test_____	87
	Figure 9A Electric Stroker_____	93
Code 9C	Electric Stroker with Brake & Bypass Valve. Disassy/Assy/Test-_____	94
	Figure 9C Electric Stroker with Brake & Bypass Valve-_____	100
Code **4	Torque Limiter Option Disassy/Assy/Test_____	101
	S23-12298 Torque Limiter, One Side of Center,CW-B, CCW-A_____	105
	S23-12299 Torque Limiter, Both Sides of Center_____	106
	S23-12300 Torque Limiter, One Side of Center, CW-A, CCW-B_____	107
Stroke Indicator	Stroke Indicator Disassy/Assy_____	108
	S13-42064 Stroke Indicator_____	109
Seal Kits	_____	110
Conversions & Formulas	_____	111

Note: Metric terms are noted in parentheses with decimal point designated by a period, as (2.25 Nm) equals 2,25 Newton meters.

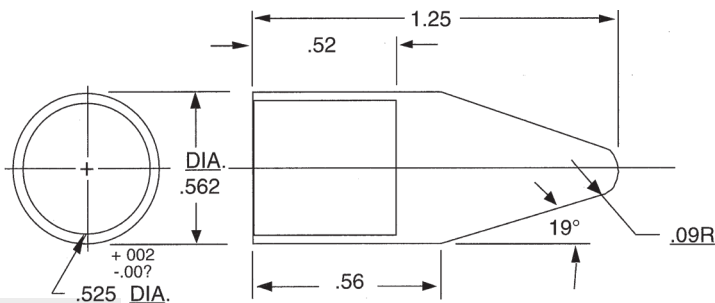

**T-1**

O-Ring installation tool

**Pump series** \_\_\_\_\_ P 6 P -2 R 1 C -4 A 2 -A -00 -B 1 -M-XXXXX

**Primary Controls** \_\_\_\_\_

1-Screw Adjustment  
 2-Cylinder Control  
 4-Rotary Servo (spring centered w/trimmer)  
 5-Electrohydraulic Stroker  
 6-Hydraulic Stroker  
 7-Servo Valve & Feedback Device  
 8-Proportional Hydraulic Stroker  
 9-Electrohydraulic Stroker  
 (All include rotary servo, pressure compensator override & displ. indicator)

**Primary Control Options** \_\_\_\_\_

0-None  
 A-Adjustable maximum volume stops  
 B-Automatic brake control  
 C-A & B above, together  
 D-10 GPM Servo Valve w/feedback potentiometer  
 E-10 GPM Servo Valve w/feedback RVDT  
 F-10 GPM Servo Valve w/pot. & manual override w/4A2 Control  
 G-10 GPM Servo Valve w/RVDT & manual override w/4A2 Control  
 H-3 pos (Spring centered w/trimmer)

**Secondary Controls** \_\_\_\_\_

2-Auxiliary Replenishment Port on Centerline  
 4-Torque Limiter and Auxiliary Replenishment Port

**Control Feature**

**500 Control**  
 00-with deadband  
 01-without deadband

**600 Control**  
 00-75-350 PSI (5-24 bar)  
 01-75-435 PSI (5-30 bar)  
 02-100-380 PSI (7-26 bar)  
 03-150-400 PSI (10.3-27.6 bar)

**700 Control**  
 00-w/o manual override shut-off  
 01-w/manual override shut-off

**800 Control**  
 00-75-350 PSI (5-24 bar)  
 01-75-435 PSI (5-30 bar)  
 02-100-380 PSI (7-26 bar)  
 03-150-400 PSI (10.3-27.6 bar)  
 04-75-250 PSI (5-17 bar)

**900 Control**  
 00-24 VDC  
 01-12 VDC  
**ALL OTHER CONTROLS USE 00**

**Control Location**  
 A-Command on Port A side  
 B-Command on Port B side  
 (Displ. indicator on opposite side)

**Allowable Controls, P\_P:**  
 102,104,2A2,2A4,2H2,2H4,402,404,4A2,4A4,4B2,4B4,  
 4C2,4C4,5A2,5A4,5C2,5C4,602,604,6B2,6B4,7D2,  
 7E2,7F2,7G2,8A2,8A4,8C2,8C4,9A2,9A4,9C2,9C4,

**Allowable Controls, P\_V:\***  
 102,104,2A2,2A4,4A2,4A4,4C2,4C4,5A2,5A4,  
 5C2,5C4,6A2,6A4,6C2,6C4,7D2,7E2,7F2,7G2,  
 8A2,8A4,8C2,8C4,9A2,9A4,9C2,9C4  
 \*P\_V not available on 24 & 30 Series

**Motor series** \_\_\_\_\_ M 6 H -2 N 1 C -2 A 0 -A -00 -M-XXXXX

**Primary Controls** \_\_\_\_\_

2-Cylinder with adjustable maximum & minimum stops  
 5-Electrohydraulic Stroker  
 6-Hydraulic Stroker  
 8-Proportional Hydraulic Stroker  
 9-Electrohydraulic Stroker (without deadband)  
 (All include rotary servo stem and displacement indicator)

**Primary Control Options** \_\_\_\_\_

0-None  
 A-Adjustable maximum volume stops

**Secondary Control options** \_\_\_\_\_

0-None  
 5-Reverse compensator (not available on 24 & 30 series)

**Control Location** \_\_\_\_\_

A-Command on Port A side  
 B-Command on Port B side

**Control Feature**

**500 Control**  
 1-without deadband

**600 Control**  
 0-170-350 PSI (11.7-24.1 bar)  
 1-200-450 PSI (17.2-31 bar)  
 2-150-380 PSI (10.3-26.2 bar)  
 3-75-250 PSI (5-17 bar)

**800 Control**  
 0-75-250 PSI (5-17 bar)  
 1-250-450 PSI (17-31 bar)

**900 Control**  
 0-24 VDC  
 0-12 VDC

**Allowable Controls: M\*V,M\*H:** 2A0,2A5,5A0,5A5,6A0,6A5,8A0,8A5,9A0,9A5

**TABLE 1 TYPICAL CHARACTERISTICS**

<b>Specifications</b>	<b>Typ. Value</b>
Control stop adjustment, 0 to full volume 1A, 2A, 4A, 4C 5A, 5C 6A, 6C 8A, 8C, 9A, 9C	6.72 Turns 8.48 Turns 6.06 Turns 5.04 Turns
Servo response time, 0 to full volume P6, P7, P8 P11, P14 P24, P30	.9 Seconds 1.5 Seconds 1.8 Seconds
Compensator off stroke response, full to 0 volume. P6, P7, P8 P11, P14 P24, P30	.050 Seconds .070 Seconds .100 Seconds
Servo shaft rotation, 0 to full volume	19 degrees
Fluid connections: Signal ports, 2A Signal ports, 2H, 60, 6A, 6B, 6C, 8A, 8C Brake port, 4B, 4C, 5C, 6B, 6C, 8C, 9C Bypass port to system pressure, 4B, 4C, 5C, 6B, 6C Bypass port to system pressure, 8C, 9C Bypass port to replenishing, 4B, 4C, 5C, 6B, 6C, 8C, 9C	1/8 Dryseal NPTF SAE -4 St. Thd. O-ring seal SAE -6 St. Thd. O-ring seal SAE -4 St. Thd. O-ring seal SAE -6 St. Thd. O-ring seal SAE -6 St. Thd. O-ring seal

**\*5A, 5C CONTROLS**

<b>Specifications</b>	<b>Typ. Value</b>
Hysteresis	Less than 5%
Linearity	Within 5%
Response	0.5 seconds, zero to full. (control response)
Temperature null shift	Less than 2% per 100° F (38°C)
Deadband	0% or 10%
Input pressure	400 psi (28 bar) nominal, range 200-1000 psi (14-70 bar)
Coil resistance	24 to 30 Ohms
Electrical input	Full stroke .275 ma. typ., 400 ma. max., Max. current 600 ma.
Torque for manual operation	20 in.-lb (2.25 Nm) with control pressure shut off.

\*Note: If the driver uses Pulse Width Modulation, (PWM) the frequency must be 2000 Hz. or higher to avoid erratic operation. Water Glycol, Phosphate Ester (including Skydrol), and Invert emulsions cannot be used with 5A and 5C controls.

**60, 6A, 6B, 6C PUMP CONTROLS**

<b>Feature</b>	<b>Control press. min. displacement</b>		<b>Control press. max. displacement</b>		<b>Max. hysteresis @ min. displacement</b>		<b>Max. hysteresis @ max. displacement</b>	
	psi	(bar)	psi	(bar)	psi	(bar)	psi	(bar)
00	60-90	(4.1-6.2)	310-360	(21.3-24.8)	30	(2.1)	50	(3.4)
01	60-90	(4.1-6.2)	410-460	(28.3-31.7)	30	(2.1)	50	(3.4)
02	100-120	(6.9-8.3)	350-400	(24.1-27.6)	30	(2.1)	50	(3.4)
03	135-165	(9.3-11.4)	375-425	(25.9-29.3)	30	(2.1)	50	(3.4)

# GOLDCUP CONTROLS CHARACTERISTICS

## 6A MOTOR CONTROLS

Feature	Control press. max. displacement		Control press. min. displacement		Max. hysteresis @ max. displacement		Max. hysteresis @ min. displacement	
	psi	(bar)	psi	(bar)	psi	(bar)	psi	(bar)
0-	155-185	(10.7-12.7)	310-360	(21.3-24.8)	30	(2.1)	50	(3.4)
1-	185-215	(12.8-14.8)	410-460	(28.3-31.7)	30	(2.1)	50	(3.4)
2-	135-165	(9.3-11.3)	350-400	(24.1-27.6)	30	(2.1)	50	(3.4)
3-	60-90	(4.1-6.2)	225-275	(15.5-19.0)	30	(2.1)	50	(3.4)

## 700 FEEDBACK CONTROLS

Specifications	Typ. Value
Input voltage	+/- 15 Volts
Input Amperes Potentiometer D.C. RVDT	3 ma 30 ma
* Output Volts @ max displacement, 19° CW rotation facing control Potentiometer D.C. RVDT	+3.1 Volts -2.3 Volts
Output impedance Potentiometer D.C. RVDT	2.5 K Ohms <1 Ohm

\*With connector terminal B at +15 Volts, terminal D at - 15 Volts. This polarity must be maintained for D.C. RVDT, Polarity is optional for potentiometer.

## 8A, 8C PUMP CONTROL

Code	Control press. min. displacement		Control press max. displacement		Max. hysteresis @ min. displacement		Max. hysteresis @ max. displacement	
	psi	(bar)	psi	(bar)	psi	(bar)	psi	(bar)
00	60-90	(4.1-6.2)	310-360	(21.3-24.8)	30	(2.1)	50	(3.4)
01	60-90	(4.1-6.2)	410-460	(28.3-31.7)	30	(2.1)	50	(3.4)
02	100-120	(6.9-8.3)	350-400	(24.1-27.6)	30	(2.1)	50	(3.4)
03	135-165	(9.3-11.4)	375-425	(25.9-29.3)	30	(2.1)	50	(3.4)
04	60-90	(4.1-6.2)	225-275	(15.5-19.0)	30	(2.1)	50	(3.4)
Torque for manual operation (no control pressure) begin stroke							7.5-20 in. lb.	(0.8-2.2 N·m)
Torque for manual operation (no control pressure) end stroke							28-58 in. lb.	(3.2-6.5 N·m)

## 8A MOTOR CONTROL

Code	Control press. min. displacement		Control press max. displacement		Max. hysteresis @ min. displacement		Max. hysteresis @ max. displacement	
	psi	(bar)	psi	(bar)	psi	(bar)	psi	(bar)
0*	60-90	(4.1-6.2)	225-275	(15.5-19.0)	30	(2.1)	50	(3.4)
1*	235-265	(16.2-18.3)	410-460	(28.3-31.7)	30	(2.1)	50	(3.4)
Signal ports							SAE - 4	
Torque for manual operation (no control pressure) begin stroke							7.5-20 in. lb.	(0.8-2.2 N·m)
Torque for manual operation (no control pressure) end stroke							28-58 in. lb.	(3.2-6.5 N·m)

## 9A, 9C PUMP CONTROL

## 9A MOTOR CONTROL

Code	mA @min. displacement	mA @max. displacement	Code	mA @max. displacement	mA @min. displacement	Coil voltage	Nom. resist.
00	360 +/- 60	650 +/- 110	0*	360 +/- 60	580 +/- 100	12 Volt	10 Ohm
01	180 +/- 30	325 +/- 55	1*	180 +/- 30	290 +/- 50	24 Volt	41 Ohm
* Hysteresis- percent of full displacement						5% typ. 8% max.	
* Linearity - percent of full displacement						within 8%	
Manual override						3/16"(4.8 mm) internal hex	
Torque to override (no signal current)						30 in.-lb (3.4 N·m) typ.	
Mating connector (supplied)						DIN 43650 type AF	

\*Specifications above are based on using a Jupiter 900 Driver with a 24 VDC supply and set at 120 Hz pulse width modulation. Performance will vary when other controls are used. 100 to 200 Hz pulse width modulation is recommended.

**CODE 1 - SCREW  
ADJUSTMENT CONTROL**

S23-12327

“A” Mounting CCW Rotation

“B” Mounting CW Rotation

S23-12328

“A” Mounting CW Rotation

“B” Mounting CCW Rotation

**DESCRIPTION**

The screw adjustment spring offsets the rotary servo to the maximum displacement as adjusted by the screw. The operator needs only to override the spring offset torque of approximately 20 lbs-in. (2.26 Nm) with the rotary servo stem to manually reduce displacement. The minimum displacement is set by the adjustable screw which determines the minimum rotary servo command. The pressure compensator override is independent of this control. A pump with this control acts as with a traditional pressure compensator. In the absence of an overriding rotary servo command the pump is held at the adjustable maximum displacement. The maximum screw is adjustable from approximately 100% to 0%. The minimum screw is nominally set at zero stroke but is adjustable from -50% to + 100% displacement.

**DISASSEMBLY**

See Figure 1

1. Remove screws (2). Remove control from pump. Examine servo plate for excessive scratching. Note if orifices in stem are open. If servo plate is scratched or orifices appear to be plugged, remove plate and servo stem by removing two socket set screws from plate, then alternately loosening the two button head screws under the set screws.
2. Remove retaining ring (4) and press the shaft assembly through the valve body.
3. Examine shoes (8) and (25) for contamination in balance pads or excessive scratching on faces. Note: the two shoes are not identical and must be installed in the proper position on reassembly.
4. Remove the plug (17) with attached parts. Remove the spools (15) and spring (20). Examine spools and bores for free motion, wear or contamination

**REWORK OF WEAR PARTS**

Description	Rework
Servo plate face	Fine stone to remove raised burrs & dings
Shear seal	Fine stone to remove raised burrs & dings. Note: grooves to supply balance pads must be present and adequate.
Control cover	Stone or lap inside face to remove raised burrs & dings.
Spool	Break sharp edges or dings.

**PREPARATION FOR ASSEMBLY**

All parts are to be inspected and be free of material defects, dirt, scratches or any foreign material. All parts are to be cleaned with a suitable cleaning solvent and all cores and passages blown out with clean dry compressed air. After cleaning and inspection, all parts are to be covered with a light film of oil and should be protected from dirt and excessive handling until assembled onto the unit. During assembly, lapped and ground surfaces should be kept lubricated and protected from nicks or surface damage.

**ASSEMBLY**

1. Apply pipe sealant and install plug (12) in body. Torque to 100 lbs-in. (11.3 Nm)
2. Press spring pins (23) into body, being careful not to mar the surface in the area of the shoe path.
3. Install O-ring (7) in groove of shear seal (8). Install shear seal with O-ring in the large hole on the servo link, on the servo shaft side. Be certain that the shear seal is sitting with the flange flush against the servo link surface.

Note: The shear seal will fit in one position only. Otherwise one side will be held up by the lip of the servo link. Shear seal (8) must be installed to face against the cover plate (10). This shear seal differs from shear seal (25) in that the face surface is machined with two .094" (2.4 mm) radius scallops.

4. Install thrust washers (9) over servo shaft and seat against the servo link.
5. Install O-ring (5) in the second groove from the end of the shaft, using assembly tool T-1.
6. Install the servo shaft assembly in the cover plate. (11).
7. Install retaining ring (4) into the groove of the servo shaft extending through the cover plate.
8. Install spools (15) into the bores in the body. Note: Reduced down diameters must

- be to the outside, and spools must freely slip into the bores.  
 9. Install spring (20) over the spool extension on one side only. See chart for location relative to the 1/8" pipe plug.  
 10. Install plugs (17) with O-rings (16). Install remaining parts in plugs.

Pump Shaft Rotation	Control mounting	Spring loc. to 1/8" plug
clockwise	A	same
clockwise	B	opposite
c/clockwise	A	opposite
c/clockwise	B	same

11. Place two spring washers (24), nested with the bent sections matching each other, into the large hole in the servo link,  
 12. Place washer (19) against the spring washers.  
 13. Install O-ring into groove in the remaining shear seal (25). Note: This shear seal does not contain the two .094" (2.4 mm) radius scallops in the face. Place on top of washer (32). Position shear seal to match the lip on the servo link.  
 14. Install control on pump and torque bolts to 30 lbs-ft. (40.8 Nm).

**PARTS LIST**

*For Figure 1 - Screw adjustment control*

*S23-12327*

*CCW - "A" Mtg., CW - "B" Mtg.*

*S23-12328*

*CW - "A" Mtg., CCW - "B" Mtg.*

ITEM	DESCRIPTION	PART NO.	QTY.
1	Servo shaft assy.	S13-48438	1
2	Screw, hwhd. 3/8-16 x 1-1/4	353-25018	4
3	NOT USED		
4	Ring, WT 5100-50	356-65070	1
5	O-ring, 70 S-1 ARP 013	671-00013	1
6	Washer, Nyltite #37-3/8"	631-45007	4
7	O-ring, 70 S-1 ARP 017	671-00017	2
8	Shear seal	033-71371	1
9	Thrust washer	350-10103	3
10	NOT USED		
11	Control cover	033-54647	1
12	Hex flush plug, 1/8" pipe	431-90204	1
13	O-ring, 90 S-1 ARP 905	691-00905	3
14	Plug, 5P5N-S	488-35028	1
15	Spool	033-72180	2
16	O-ring, 90 S-1 ARP 906	691-00906	2
17	Plug	033-91889	2
18	Nut, cover	033-91890	2
19	Thrust washer	350-10064	1
20	Spring	033-72198	1
21	Soc. setscrew, 10-32 x 1	311-50002	2
22	Nut	333-67000	2
23	Spring pin	325-12120	2
24	Finger spring	350-10067	2
25	Shear seal	033-70525	1
26	Control cover gasket	033-91058	1

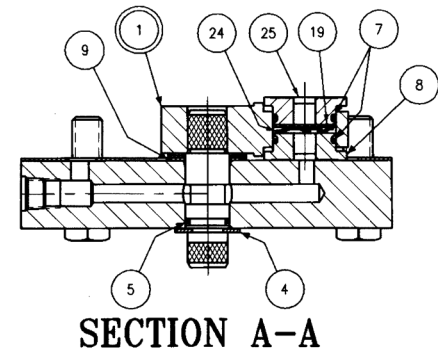
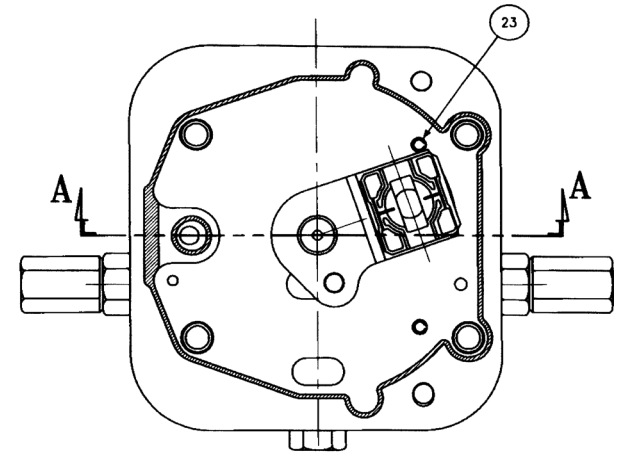
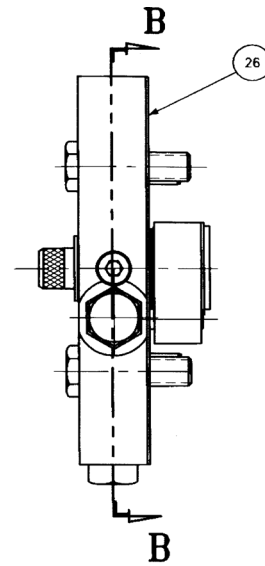
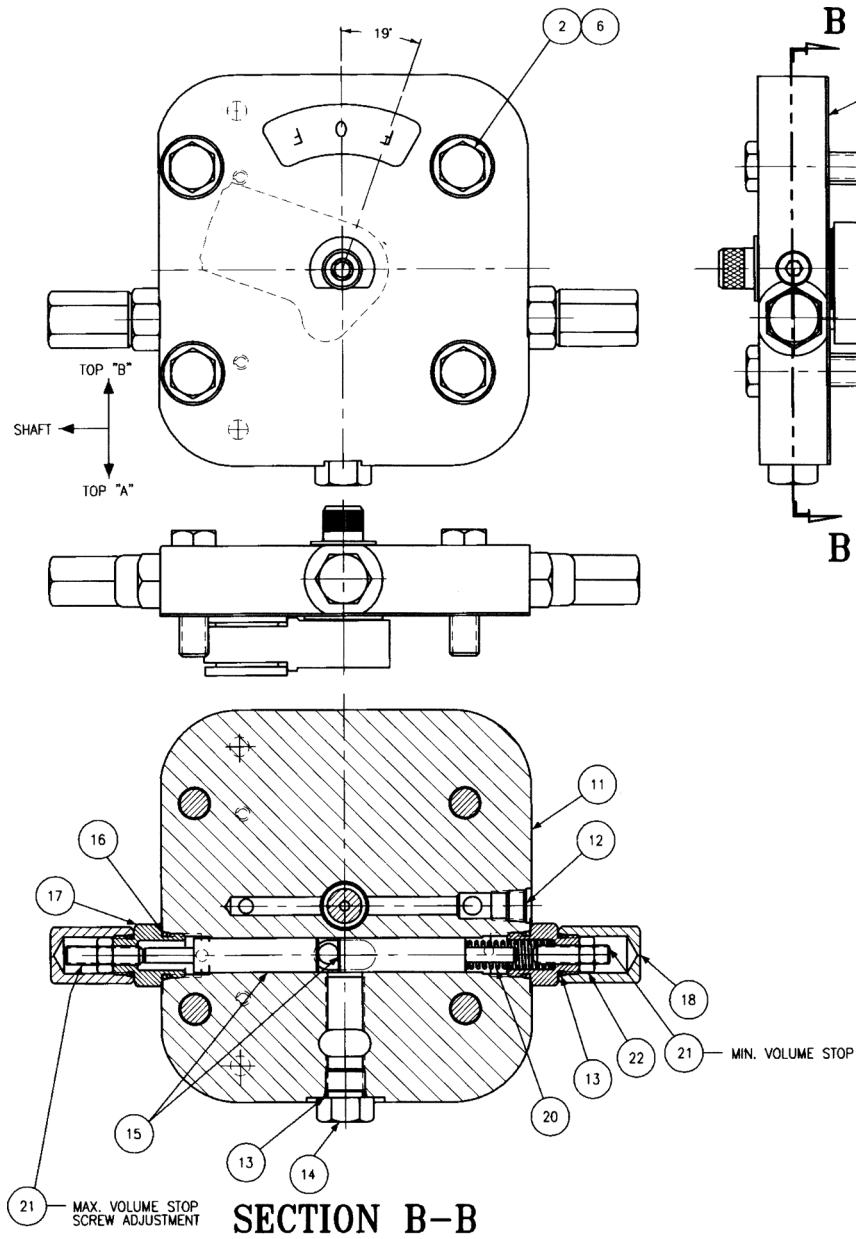

FIGURE 1  
 SCREW ADJUSTMENT 1-SIDE OF CENTER,  
 SPRING OFF SET TO FULL W/ADJ. MAX./MIN.  
 VOLUME STOPS, CCW-B & CW-A

**CODE 2A CYLINDER CONTROL**

S23-12338

"A" Mounting CCW Rotation pump

"B" Mounting CW Rotation pump

S23-12340

"A" Mounting CW Rotation pump

"B" Mounting CCW Rotation pump

S23-12326

"B" Mounting motor

S23-12329

"A" Mounting motor

**DESCRIPTION**

These controls provide the capability of hydraulically selecting pre-set displacements. On pump controls, the control is spring biased toward zero displacement. Maximum and minimum displacements are adjustable from zero to full. On motor controls, the control is spring offset toward full displacement. Maximum and minimum displacements are adjustable from 1/3 stroke to full. Stroking pistons engage a pin on the servo arm. When signal pressure is applied to the piston opposite to the spring, the piston moves, causing the control arm to move to the other position. With a lever attached to the input shaft, displacement may be manually controlled between these two limits when there is no control signal

**DISASSEMBLY**

See Figure 2A

1. Remove screws (2). Remove control from pump. Examine servo plate for excessive scratching. Note if orifices in stem are open. If servo plate is scratched or orifices appear to be plugged, remove plate and servo stem by removing two socket set screws from plate, then alternately loosening the two button head screws under the set screws.
2. Remove retaining ring (4) and press the shaft assembly through the valve body.
3. Examine shoes (8) and (25) for contamination in balance pads or excessive scratching on faces. Note: the two shoes are not identical and must be installed in the proper position on reassembly.
4. Remove the plug (18) with attached parts. Remove the spools (15) and/or (22), and spring (16). Observe spools and bores for free motion, wear or contamination

**PREPARATION FOR ASSEMBLY**

All parts are to be inspected and free of material defects, dirt, scratches or any foreign material. All parts are to be cleaned with a suitable cleaning solvent and all cores and passages blown out with clean dry compressed air. After cleaning and inspection, all parts are to be covered with a light film of oil and should be protected from dirt and excessive handling until assembled onto the unit. During assembly, lapped and ground surfaces should be kept lubricated and protected from nicks or surface damage.

**REWORK OF WEAR PARTS**

Description	Rework
Servo plate face	Fine stone to remove raised burrs & dings
Shear seal	Fine stone to remove raised burrs & dings. Note: grooves to supply balance pads must be present and adequate.
Control cover	Stone or lap inside face to remove raised burrs & dings.
Spool	Break sharp edges or dings.

**ASSEMBLY**

1. Apply pipe sealant and Install plug (12) in body. Torque to 100 lbs-in. (11.3 Nm)
2. Press spring pins (23) into body, being careful not to mar the surface in the area of the shoe path.
3. Install O-ring in groove of shear seal (8). Install shear seal with O-ring in the large hole on the servo link, on the servo shaft side. Be certain that the shear seal is sitting with the flange flush against the servo link surface.

Note: The shear seal will fit in one position only. Otherwise one side will be held up by the lip of the servo link. Shear seal (8) must be installed to face against the cover plate (10). This shear seal differs from shear seal (25) in that the face surface is machined with two .094" (2.4 mm) radius scallops.

4. Install needle bearing (9) over servo shaft and seat against the servo link. Install

- thrust washer (6) over needle bearing.
- 5. Install O-ring (5) in the second groove from the end of the shaft., using installation tool T-1
- 6. Install the servo shaft assembly in the control cover (10).

Note: The dowel pin in the arm must be positioned in the rectangular slot beside the shaft hole. This will position the shear seal (8) face against the cover.

- 7. Install retaining ring (4) into the groove of the servo shaft extending through the control cover.
- 8. Install spools (15) and/or (22) into the bores in the body. Note: reduced down diameters must be to the outside, and spools must freely slip into the bores. Pump controls use two short spools (22). Motor controls use one long spool, (15) on the side with the spring, and one short spool (22), on the opposite side. See chart for spring location relative to item (12) figure 2A.

<b>Pump Shaft Rotation</b>	<b>Control mounting</b>	<b>Spring loc. to 1/8" plug (12)</b>
clockwise	A	same
clockwise	B	opposite
c/clockwise	A	opposite
c/clockwise	B	same

<b>Motor control mtg.</b>	<b>Long spool and Spg. loc. to 1/8" plug (12)</b>
A	same
B	opposite

- 9. Install spring (16) over the spool extension on indicated side.
- 10. Install plugs (17) with O-rings (16). Install remaining parts in plugs.
- 11. Place two spring washers (24), nested with the bent sections matching each other, into the large hole in the servo link.
- 12. Place washer (11) against the spring washers.
- 13. Install O-ring into groove in the remaining shear seal (25). Note: This shear seal does not contain the two .094" (2.4 mm) radius scallops in the face. Place on top of washer (32). Position shear seal to match the lip on the servo link.
- 14. Install control on pump control pad, over dowels, with gasket, (26). Place new Nyltite washers (3) on screws (2). Torque to 30 lbs-ft. (40.8 Nm).

**TEST**

- 1. Connect lever to input shaft. With unit running, manually stroke the shaft. Do not exceed 100 lbs-in. (11.3 Nm) torque. Pump or motor cam shall follow the motion of the input shaft.  
Input shaft and cam shall return to the spring biased position when the lever is released.
- 2. Set the maximum stop screw for full displacement. Set the minimum stop position. For motor controls, minimum stroke shall be no less than 25% and no more than 33% of full stroke, with the lever at minimum stroke and the minimum stop screw backed away from contact with the piston. Caution! do not allow motor to exceed rated RPM. For pump controls, set the minimum stop screw for zero displacement. Lock in position.
- 3. Apply 300 to 600 psi servo supply to signal port. Control shaft shall rotate and pump or motor shall follow stroke of input shaft.

<b>Pump shaft rotation</b>	<b>Control mounting</b>	<b>Signal port</b>	<b>Tank port</b>
clockwise	A	Y	X
clockwise	B	X	Y
c/clockwise	A	X	Y
c/clockwise	B	Y	X

<b>Motor control mounting</b>	<b>Signal port</b>	<b>Tank port</b>
A	X	Y
B	Y	X

"Y" port is adjacent to 1/8" plug (12)

- 4. Drop signal pressure to minimum. Control shall return to the spring offset position, and pump or motor shall return to the initial displacement.

**PARTS LIST**

*For Figure 2A - Cylinder control*

ITEM	DESCRIPTION	PART NO.	QTY. PUMP	QTY. MTR.
1	Servo shaft assy.	S13-48438	1	1
2	Screw, hwhd. 3/8-16 x 1-1/4	353-25018	4	4
3	Washer Nyltite #37	631-45007	4	4
4	Ring, WT 5100-50	356-65070	1	1
5	O-ring, 70 S-1 ARP 013	671-00013	1	1
6	Washer, hardened	350-10141	1	1
7	O-ring, 70 S-1 ARP 017	671-00017	2	2
8	Shear seal	033-71371	1	1
9	Needle bearing	230-82141	1	1
10	Control cover	033-91154	1	1
11	Thrust washer	350-10064	1	1
12	Hex flush plug 1/8" pipe	431-90204	1	1
13	Nut	333-67000	2	2
14	NOT USED			
15	Spool, 2.6" (66.0 mm) lg.	033-70844	-	1
16	Spring	033-72181	1	1
17	O-ring, 90 S-1 ARP 906	691-00906	2	2
18	Plug	033-91889	2	2
19	Soc. setscrew.	311-50002	2	2
20	Nut, cover	033-91890	2	2
21	O-ring	691-00905	2	2
22	Spool, 2.26" (57.4 mm) lg.	033-70845	2	1
23	Spring pin	325-12120	2	2
24	Finger spring	350-10067	2	2
25	Shear seal	033-70525	1	1
26	Control cover gasket	033-91058	1	1

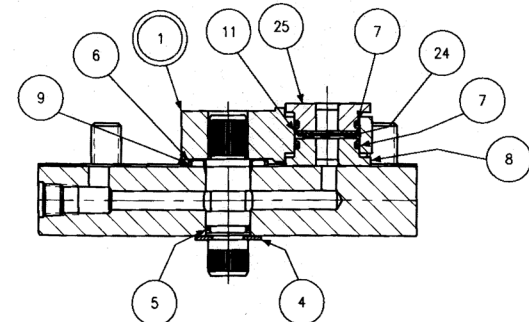
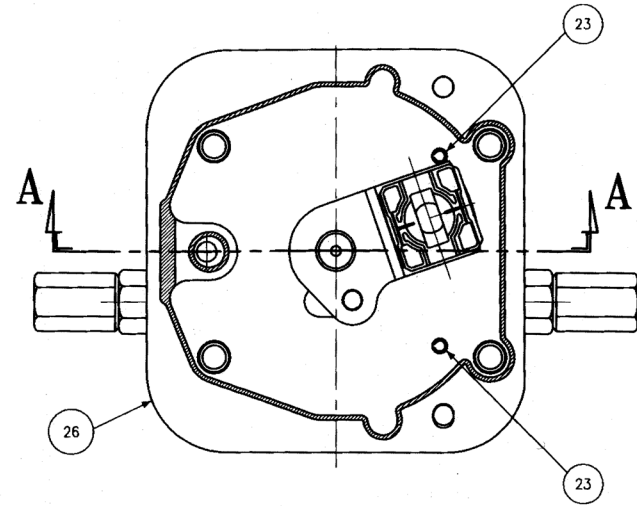
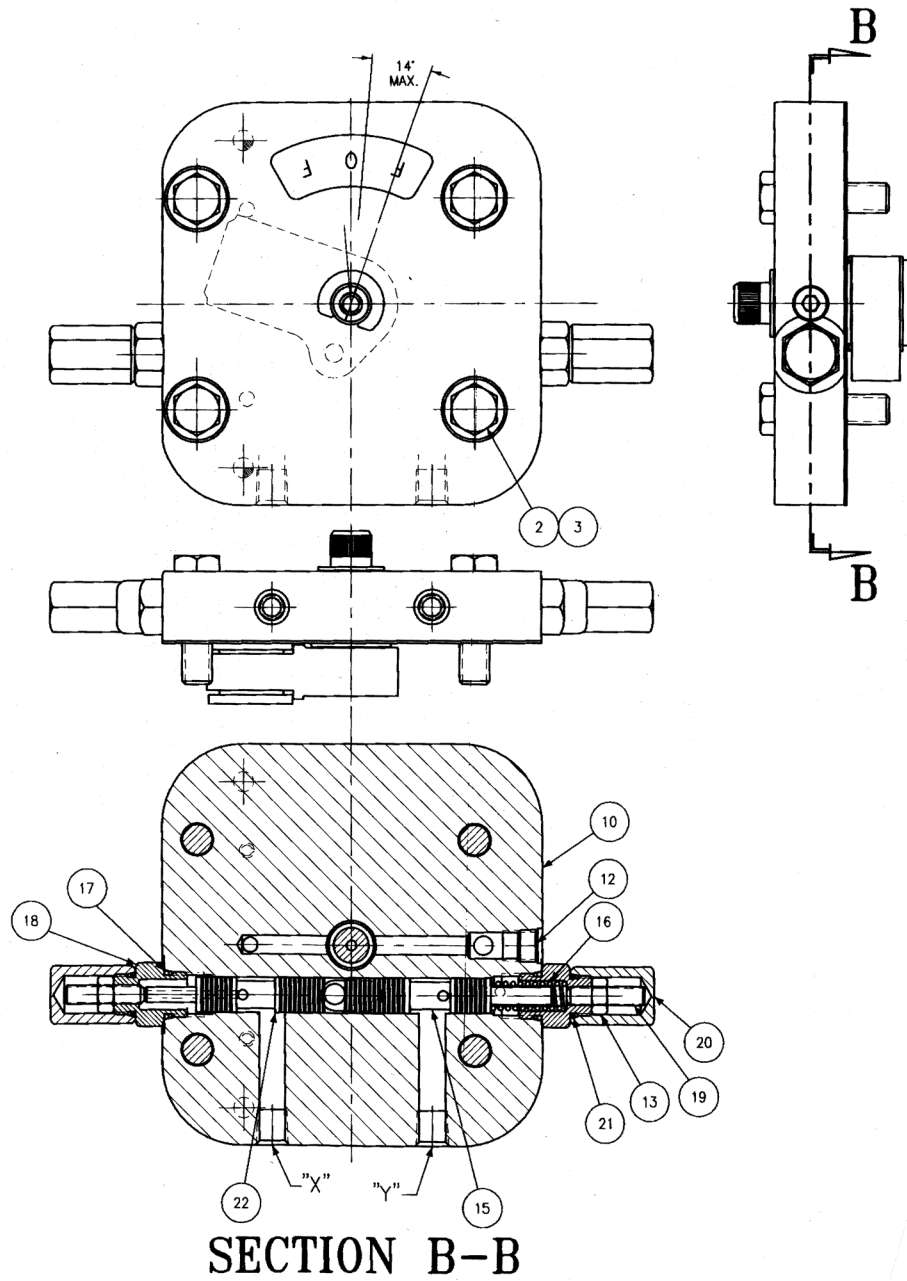

**SECTION A-A**

ITEM 1 NOT SHOWN IN TRUE POSITION

**FIGURE 2A  
CYLINDER CONTROL**

S23-12329

**CODE 2H 3 POSITION  
CYLINDER CONTROL**

S23-12358

**DESCRIPTION**

Code 2H cross center pump controls are spring centered and can be piloted to full displacement either side of center by introducing a pilot pressure into the control ports. A trimmer adjustment provides for accurate setting of zero stroke position. Maximum displacements are adjustable from zero to full stroke. When there is no control signal, displacement may be manually controlled between these two limits with a lever attached to the input shaft.

**DISASSEMBLY**

See Figure 2H

1. Remove screws (17). Remove control from pump. Examine servo plate for excessive scratching. Note if orifices in stem are open. If servo plate is scratched or orifices appear to be plugged, remove plate and servo stem by removing two socket set screws from plate, then alternately loosening the two button head screws under the set screws.
2. Remove retaining ring (4) and press the shaft assembly through the valve body.
3. Examine shoes (8) and (25) for contamination in balance pads or excessive scratching on faces. Note: the two shoes are not identical and must be installed in the proper position on reassembly.
4. Remove the plug (29) with attached parts. Remove the spools (27).
5. Remove plugs (22). Remove springs (20) and spools (18). Examine spools and bores for free motion, wear or contamination.
6. If trimmer adjustment must be removed, carefully tap the spring pin (14) in till flush with O.D. of screw (13). Remove nut (15), and screw (14). Remove spring pin from screw.

**PREPARATION FOR ASSEMBLY**

All parts are to be inspected and be free of material defects, dirt, scratches or any foreign material.  
 All parts are to be cleaned with a suitable cleaning solvent and all cores and passages blown out with clean dry compressed air.  
 After cleaning and inspection, all parts are to be covered with a light film of oil and should be protected from dirt and excessive handling until assembled onto the unit.  
 During assembly, lapped and ground surfaces should be kept lubricated and protected from nicks or surface damage.

**REWORK OF WEAR PARTS**

Description	Rework
Servo plate face	Fine stone to remove raised burrs & dings
Shear seal	Fine stone to remove raised burrs & dings. Note: grooves to supply balance pads must be present and adequate.
Control cover	Stone or lap inside face to remove raised burrs & dings.
Spool	Break sharp edges or dings.

**ASSEMBLY**

1. Apply pipe sealant and Install plug (10) in body. Torque to 100 lbs-in. (11.3 Nm)
2. Press rollpins (23) into body, being careful not to mar the surface in the area of the shoe path.
3. Press pin (12) into screw (13) to 0.38" (9.65 mm) extended length.
4. Install screw (13) into body Pin (12) should extend into spool bore approximately .090" (2.29 mm). The eccentric pin must be indexed so that it is offset towards the outside surface of the cover plate. The drilled hole for the spring pin (14) should be approximately centered in the slotted opening in the cover plate. Install spring pin (14) into trimmer assembly. Leave approximately one-half length of pin extending from screw. This will allow approximately plus or minus 45° rotation of the trimmer assembly. Install nut (15), O-ring (16), plug (32) and O-ring (31).
5. Install O-ring in groove of shear seal (8). Install shear seal with O-ring in the large hole on the servo link, on the servo shaft side. Be certain that the shear seal is sitting with the flange flush against the servo link surface.

Note: The shear seal will fit in one position only. Otherwise one side will be held up by the lip of the servo link. Shear seal (8) must be installed to face against the cover plate (11). This shear seal differs from shear seal (25) in that the face surface is machined with two .094" (2.4 mm) radius scallops.

6. Install thrust washers (9) over servo shaft and seat against the servo link.
7. Install O-ring (5) in the second groove from the end of the shaft, using installation tool T-1.

8. Install the servo shaft assembly in the control cover (11), engaging the pins in the slots, with the arm centered between the spring pins.
9. Install retaining ring (4) into the groove of the servo shaft extending through the control cover.
10. Install spools (18) into the bores in the body adjacent to the trimmer screw. Note that reduced down diameters must be to the outside, and spools must freely slip into the bores.
11. Install springs (20). Install O-rings (21) over plugs (22) and install plugs.
12. Install spools (27) in the remaining bores. Note that reduced down diameters must be to the outside, and spools must freely slip into the bores.
13. Install O-rings (21) on plugs (29). Install plugs in body.
14. Install adjusting screws (2), nuts (3) O-rings (30), plugs (34) and O-rings (33) into plugs (29).
15. Place two spring washers (24), nested with the bent sections matching each other, into the large hole in the servo link.
16. Place washer (11) against the spring washers.
17. Install O-ring into groove in the remaining shear seal (25). Note: This shear seal does not contain the two .094" (2.4 mm) radius scallops in the face. Place on top of washer (32). Position shear seal to match the lip on the servo link.
18. Install control over dowels, with gasket, (26), washers (6) and screws (17). Torque to 30 lbs-ft. (40.8 Nm).

## TEST

1. Connect lever to input shaft. With unit running, manually stroke the shaft. Do not exceed 100 lbs-in. (11.3 Nm) torque on shaft. Pump shall follow the motion of the input shaft.  
Input shaft and cam shall return to center when the lever is released.
2. Set the maximum stop screws for full displacement.
3. Remove plug from trimmer adjustment. Loosen locknut and adjust center position with a screwdriver. Lock on zero stroke position. Stroke pump and release handle, both sides of center. Pump shall return to zero consistently.
4. Apply 300 to 600 psi (20.5 to 41 bar) servo supply to one control port . The remaining control port shall be connected to tank. Control shaft shall rotate and pump shall follow stroke of input shaft.
5. Drop signal pressure to minimum. Control shall return to center.
6. Repeat procedure with signal applied to the other control port.

**PARTS LIST**

For Figure 2H -3 Position cylinder control

S23-12358

ITEM	DESCRIPTION	PART NO.	QTY.
1	Servo shaft assy.	S23-12022	1
2	Soc. setscrew	311-50002	2
3	Nut, cover	033-91890	2
4	Ring, WT 5100-50	356-65070	1
5	O-ring, 70 S-1 ARP 013	671-00013	1
6	Washer, Nyltite #37-3/8"	631-45007	4
7	O-ring, 70 S-1 ARP 017	671-00017	2
8	Shear seal	033-71371	1
9	Thrust washer	350-10103	3
10	Hex flush plug, 1/8" pipe	431-90204	1
11	Control cover	033-57807	1
12	Pin	033-71003	1
13	Screw, center trim	033-91042	1
14	Spring pin 1/8 x 3/8	325-08060	1
15	Nut	033-91041	1
16	O-ring, 70 S-1 ARP 015	671-00015	1
17	Screw, hwhd. 3/8-16 x 1-1/4	353-25018	4
18	Spool	033-72180	2
19	Thrust washer	350-10064	1
20	Spring	033-72181	2
21	O-ring, 90 S-1 ARP 906	691-00906	4
22	Plug	033-70840	2
23	Spring pin, 3/16 x 3/4	325-12120	2
24	Finger spring	350-10067	2
25	Shear seal	033-70525	1
26	Control cover gasket	033-91058	1
27	Spool	033-70845	2
28	Dust plug, 7/16-20	449-00506	2
29	Plug	033-91889	2
30	Nut	333-67000	2
31	O-ring, 90 S-1 ARP 905	691-00905	3
32	Plug, 5HP5N-S	488-35020	1
33	NOT USED		
34	NOT USED		

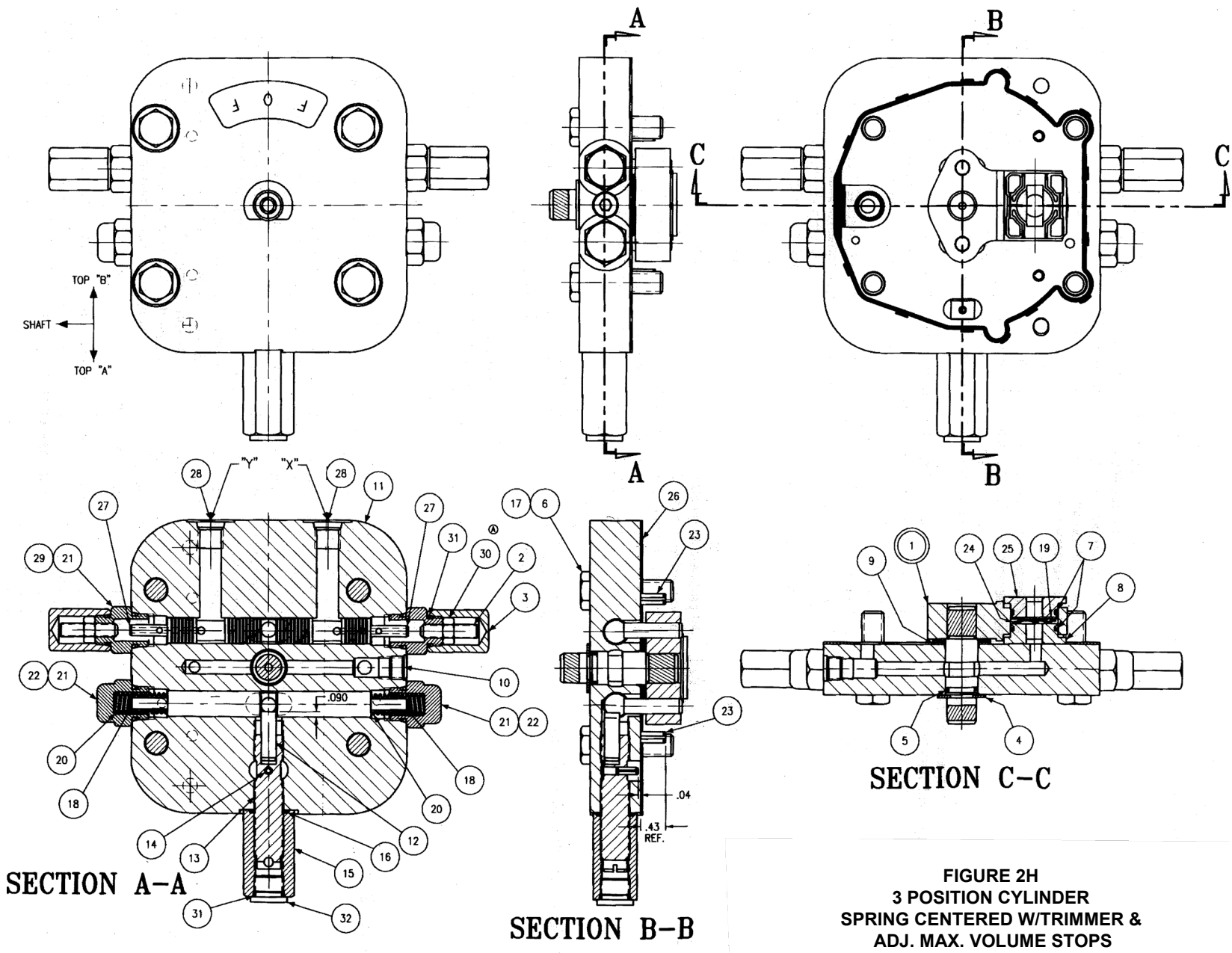

**FIGURE 2H**  
**3 POSITION CYLINDER**  
**SPRING CENTERED W/TRIMMER &**  
**ADJ. MAX. VOLUME STOPS**

S23-12358

**CODE 40\*/4A\* ROTARY SERVO  
SPRING CENTERED WITH  
TRIMMER**

S23-12344 - 4O (Less stops)  
S23-12325 - 4A (With stops)

**DESCRIPTION**

Code 40\* and 4A\* cross center pump controls are spring centered and can be manually stroked to full displacement either side of center with approximately 20 lbs-in. (2.26 Nm) torque. The spring centered position may be adjusted externally to approximately +/- 5% displacement. In the 4A control, maximum displacements are adjustable from zero to full stroke.

**DISASSEMBLY**

See Figure 4A

1. Remove screws (2). Remove control from pump. Examine servo plate for excessive scratching. Note if orifices in stem are open. If servo plate is scratched or orifices appear to be plugged, remove plate and servo stem by removing two socket set screws from plate, then alternately loosening the two button head screws under the set screws.
2. Remove retaining ring (4) and press the shaft assembly through the valve body.
3. Examine shoes (8) and (28) for contamination in balance pads or excessive scratching on faces. Note: the two shoes are not identical and must be installed in the proper position on reassembly.
4. Remove plugs (22) with attached parts. Remove springs (20) and spools (18). Examine spools and bores for free motion, wear or contamination.
5. If trimmer adjustment must be removed, carefully tap the spring pin (14) in till flush with O.D. of screw (13). Remove nut (15), and screw (14). Remove spring pin from screw.

**PREPARATION FOR ASSEMBLY**

All parts are to be inspected and be free of material defects, dirt, scratches or any foreign material.

All parts are to be cleaned with a suitable cleaning solvent and all cores and passages blown out with clean dry compressed air.

After cleaning and inspection, all parts are to be covered with a light film of oil and should be protected from dirt and excessive handling until assembled onto the unit.

During assembly, lapped and ground surfaces should be kept lubricated and protected from nicks or surface damage.

**REWORK OF WEAR PARTS**

Description	Rework
Servo plate face	Fine stone to remove raised burrs & dings
Shear seal	Fine stone to remove raised burrs & dings. Note: grooves to supply balance pads must be present and adequate.
Control cover	Stone or lap inside face to remove raised burrs & dings.
Spool	Break sharp edges or dings.

**ASSEMBLY**

1. Apply pipe sealant and install plug (10) in body. Torque to 100 lbs-in. (11.3 Nm)
2. Press spring pins (26) into body, being careful not to mar the surface in the area of the shoe path.
3. Press pin (12) into screw (13) to 0.38" (9.65 mm) extended length.
4. Install screw (13) into body Pin (12) should extend into spool bore approximately .090" (2.29 mm). The eccentric pin must be indexed so that it is offset towards the outside surface of the cover plate. The drilled hole for the spring pin (14) should be approximately centered in the slotted opening in the cover plate. Install spring pin (14) into trimmer assembly. Leave approximately one-half length of pin extending from screw. This will allow approximately plus or minus 45° rotation of the trimmer assembly. Install nut (15), O-ring (16), plug (3) and O-ring (17).
5. Install O-ring (7) in groove of shear seal (8). Install shear seal with O-ring in the large hole on the servo link, on the servo shaft side. Be certain that the shear seal is sitting with the flange flush against the servo link surface.

Note: The shear seal will fit in one position only. Otherwise one side will be held up by the lip of the servo link. Shear seal (8) must be installed to face against the cover plate (11). This shear seal differs from shear seal (28) in that the face surface is machined with two .094" (2.4 mm) radius scallops.

6. Install thrust washers (9) over servo shaft and seat against the servo link.
7. Install O-ring (5) in the second groove from the end of the shaft, using installation tool T-1.

8. Install the servo shaft assembly into the control cover (11), engaging the pin in the slot.
9. Install retaining ring (4) into the groove of the servo shaft extending through the control cover.
10. Install spools (18) into the bores in the body. Note that reduced down diameters must be to the outside, and spools must freely slip into the bores.
11. Install springs (20). Install O-rings (21) over plugs (22) and install plugs.
14. For the 4A control, install adjusting screws (23), nuts (24), O-rings (30), plugs (31) and O-rings (25) into plugs (22).
15. Place two spring washers (27), nested with the bent sections matching each other, into the large hole in the servo link.
16. Place washer (19) against the spring washers.
17. Install O-ring (7) into groove in the remaining shear seal (28). Note: This shear seal does not contain the two .094" (2.4 mm) radius scallops in the face. Place on top of washer (19). Position shear seal to match the lip on the servo link.
18. Install control over dowels, with gasket, (29), washers (6), and screws (2). Torque to 30 lbs-ft. (40.8 Nm).

## TEST

1. Connect lever to input shaft. With unit running, manually stroke the shaft. Do not exceed 100 lbs-in. (11.3 Nm) torque on shaft. Pump shall follow the motion of the input shaft.  
Input shaft and cam shall return to center when the lever is released.
2. For 4A controls, set maximum stop screws for full displacement.
3. Remove plug from trimmer adjustment. Loosen locknut and adjust center position with a screwdriver. Lock on zero stroke position. Stroke pump and release handle, both sides of center. Pump shall return to zero displacement consistently.

**PARTS LIST**

*For Figure 4A - Rotary servo  
spring centered w/trimmer*

*S23-12344 - 40\* Fixed stops*

*S23-12325 - 4A\* Adjustable max.  
volume stops*

ITEM	DESCRIPTION	PART NO.	QTY 40*	QTY 4A*
1	Servo shaft assembly	S13-48438	1	1
2	Screw, 3/8-16 x 1.25	353-25018	4	4
3	Plug, 5HP5N-S	488-35020	1	1
4	Ring, WT 5100-50	356-65070	1	1
5	O-ring, 70 S-1 ARP 013	671-00013	1	1
6	Washer Nytlite #37	631-45007	4	4
7	O-ring, 70 S-1 ARP 017	671-00017	2	2
8	Shear seal	033-71371	1	1
9	Washer, Thrust	350-10103	3	3
10	1/8 Pipe plug	431-90204	1	1
11	Cover plate	033-53576	1	1
12	Pin	033-71003	1	1
13	Screw, center trim	033-91042	1	1
14	Spring pin, 1/8 x 3/8	325-08060	1	1
15	Nut, hex	033-91041	1	1
16	O-ring, 70 S-1 ARP 015	671-00015	1	1
17	O-ring, 90 S-1 ARP 905	691-00905	1	3
18	Spool	033-72180	2	2
19	Thrust Washer	350-10064	1	1
20	Spring	033-72181	2	2
21	O-ring, 90 S-1 ARP 906	691-00906	2	2
22	Plug	033-70840	2	-
	Plug	033-91889	-	2
23	Soc setscrew	311-50002	-	2
24	Nut, cover	033-91890	-	2
25	Nut	333-67000	-	2
26	Spring pin 3/16 x 3/4	325-12120	2	2
27	Finger spring washer	350-10067	2	2
28	Shear seal	033-70525	1	1
29	Gasket	033-91058	1	1
30	NOT USED			
31	NOT USED			

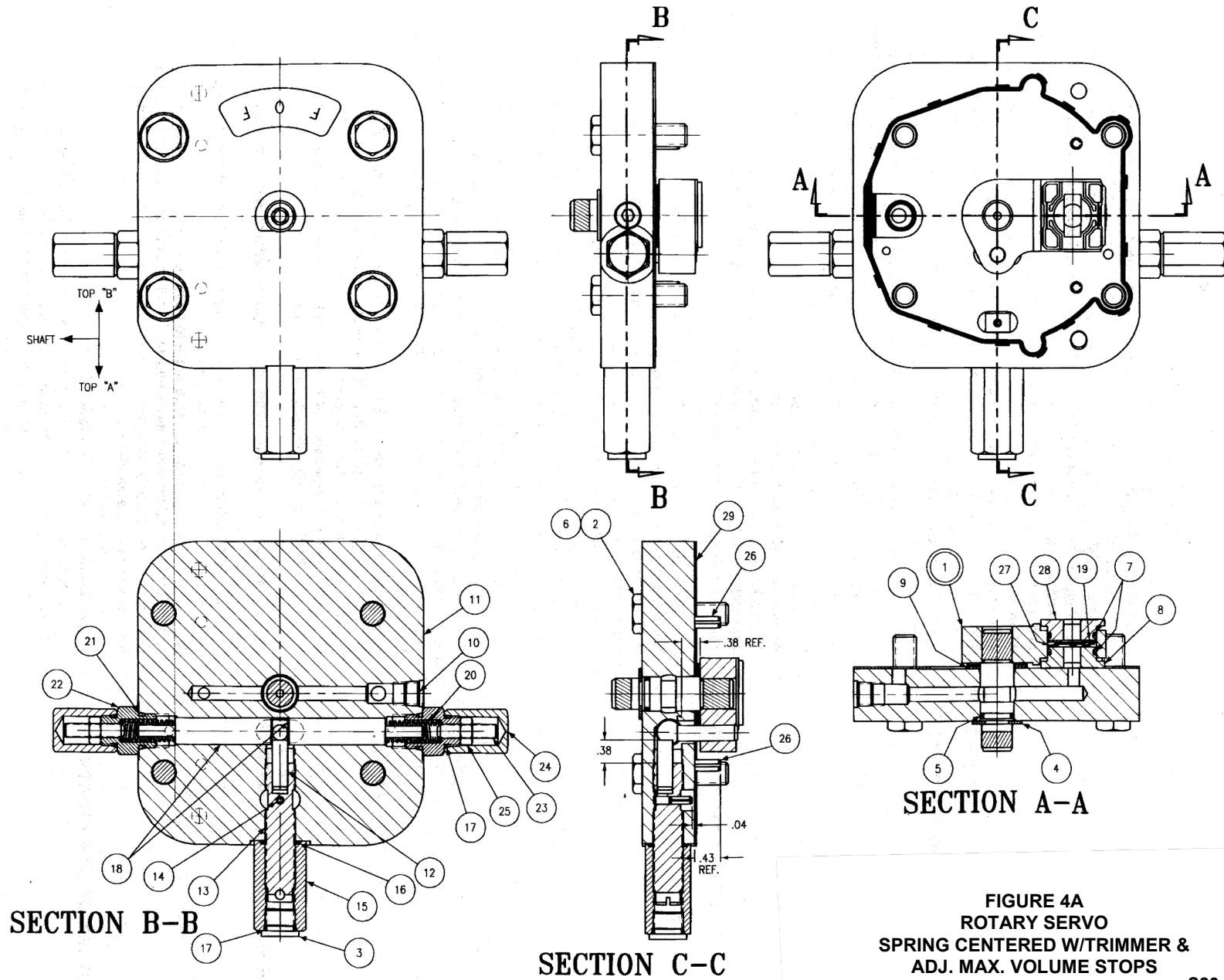

**FIGURE 4A**  
**ROTARY SERVO**  
**SPRING CENTERED W/TRIMMER &**  
**ADJ. MAX. VOLUME STOPS**

S23-12325

**CODE 4B\*/4C\* ROTARY SERVO  
SPRING CENTERED WITH  
TRIMMER, BRAKE AND  
BYPASS VALVE**

S23-12343 (4B\*)  
S23-12324 (4C\*)

**DESCRIPTION**

Code 4B\* and 4C\* cross center pump controls are spring and pressure centered and can be manually stroked to full displacement either side of center with approximately 20 lbs-in. (2.26 Nm) torque. The centered position may be adjusted externally to approximately +/- 5% displacement. In the 4C control, maximum stops may be adjusted from full to zero displacement.

In the same body is contained the brake and bypass valve option. A brake spool, when energized, connects the brake port to servo pressure. When de-energized, a spring shifts the spool, connecting the brake port to tank. Another port, located on the end of the brake valve, is closed by the energizing of the brake spool. When de-energized, this port dumps both pump system ports to the replenishing source, thus bypassing the small flow generated by slight errors on zero position.

The operation is controlled in this manner: A restricted servo flow is applied to shift the brake spool. This flow is dumped when a slot in the servo plate aligns with a passage connecting to this spool. This occurs when the pump is on zero stroke. Another restricted flow is applied to a spool adjacent to the brake spool. This flow is also connected to a passage in one centering piston, containing a ball and seat. When the control is off center, the ball seats, sealing the passage, to apply servo pressure to the spool. When the control is on center, a pin extending from the other centering piston pushes the ball off the seat, to dump the flow.

The brake spool is thus de-energized to set the brake when BOTH the pump cam is at zero stroke and the rotary servo is at zero command. If the pump is on stroke or the input is on stroke, the brake spool is energized, releasing the brake.

**DISASSEMBLY**  
See Figure 4C

1. Disconnect brake and bypass lines from control. Remove screws (2). Remove control from pump. Examine servo plate for excessive scratching. Note if orifices in stem are open. If servo plate is scratched or orifices appear to be plugged, remove plate and servo stem by removing two socket setscrews from plate, then alternately loosening the two button head screws under the set screws.
2. Remove retaining ring (4) and press the shaft assembly through the valve body.
3. Examine shoes (8) and (50) for contamination in balance pads or excessive scratching on faces. Note: the two shoes are not identical and must be installed in the proper position on reassembly.
4. Remove plugs (28) with attached parts. Remove springs (27), pistons (26), and spools (22), with attached parts. Do not disassemble unless parts are damaged. Examine spools, pistons and bores for free motion, wear or contamination.
5. If trimmer adjustment must be removed, carefully tap the spring pin (17) in till flush with O.D. of screw (16). Remove nut (18), and screw (16). Remove spring pin (17) from screw.
6. Remove bypass valve body (39) with fitting (41) piston (42) and spring (37). Remove plug (35) and spring (34). Remove spools (33) and (36).
7. Remove shoe (48), and spring (47).
8. Blow through passages to check two orifices (11) and orifice (10) in body for contamination. Check passages in body for free flow.

**PREPARATION FOR ASSEMBLY**

All parts are to be inspected and be free of material defects, dirt, scratches or any foreign material.

All parts are to be cleaned with a suitable cleaning solvent and all cores and passages blown out with clean dry compressed air.

After cleaning and inspection, all parts are to be covered with a light film of oil and should be protected from dirt and excessive handling until assembled onto the unit.

During assembly, lapped and ground surfaces should be kept lubricated and protected from nicks or surface damage.

**REWORK OF WEAR PARTS**

Description	Rework
Servo plate face	Fine stone to remove raised burrs & dings
Shear seal	Fine stone to remove raised burrs & dings. Note: grooves to supply balance pads must be present and adequate.
Control cover dings.	Stone or lap inside face to remove raised burrs & dings.
Spool	Break sharp edges or dings.

## ASSEMBLY

1. Install Lee Plug in body using installation tool and gage.
2. Install orifices (10) and (11) in body. Torque to 25 lbs-in. (2.8 Nm). Make sure that the orifice (11) in the deeper bore extends past the wall of the valve bore and will not interfere with spool (33) or spool (22) action.
3. Apply pipe sealant and install plugs (14) in body. Torque to 100 lbs-in. (11.3 Nm)
4. Press rollpins (43) into body, being careful not to mar the surface in the area of the shoe path.
5. Install O-ring (7) in groove of shear seal (8). Install shear seal with O-ring in the large hole on the servo link, on the servo shaft side. Be certain that the shear seal is sitting with the flange flush against the servo link surface.

Note: The shear seal will fit in one position only. Otherwise one side will be held up by the lip of the servo link. Shear seal (8) must be installed to face against the cover plate (12). This shear seal differs from shear seal (50) in that the face surface is machined with two .094" (2.4 mm) radius scallops.

6. Install needle bearing (9) over servo shaft and seat against the servo link. Install thrust washer (54) over needle bearing.
7. Install O-ring (5) in the second groove from the end of the shaft, using installation tool T-1.
8. Install the servo shaft assembly in the control cover (12), engaging the pin in the slot.
9. Install retaining ring (4) into the groove of the servo shaft extending through the control cover.
10. Press pin (15) into screw (16) to 0.38" (9.65 mm) extended length.
11. Install screw (16) into body. Pin (15) should extend into spool bore approximately .090" (2.29 mm). The eccentric pin must be indexed so that it is offset towards the outside surface of the cover plate. The drilled hole for the spring pin (17) should be approximately centered in the slotted opening in the cover plate. Install spring pin (17) into trimmer assembly. Leave approximately one-half length of pin extending from screw. This will allow approximately plus or minus 45° rotation of the trimmer assembly. Install nut (18) with O-ring (19), locking trimmer in position. Install O-ring (52) and plug (53).
12. Assemble seat insert (20) and threaded insert (21) into spools (22), using loctite #271 per instructions on bottle. Inserts must be assembled into the spool end nearest the 1/8" (3.18 mm) cross drilled holes.
13. When assembled spools (22) are installed in cover plate (12), they are held against the eccentric pin of the trimmer assembly by springs (27). In this position, adjusting screw (24) must have the ball (23) unseated by .012" (0.305 mm) to cause brake release at 5% of stroke. A special fixture permits adjustment to this setting per AP-01925. In the absence of this fixture, drop ball (23) into the spool containing the seat insert. Hold the ball against the seat by inserting piston (26) into the bore. Hold the two spools (22) with inserts together and set the adjusting screw (24) to where it just contacts the ball. Turn the adjusting screw in 8 3/8 turns past this point and lock with setscrew (25), being careful not to disturb the setting.
14. Retain ball (23) in spool bore by installing spring pin (17). Make sure that the ends of the spring pin do not extend beyond the O.D. of the spool.
15. Install pistons (26) into the spools (22). Install spool assemblies in the bore containing the trimmer adjustment. The spool containing the ball is to be on the side with the orifice (11).
16. Install springs (27) over pistons. Install plugs (28) and O-rings (29).
17. Install spools (33) and (36) into the other cross-bore in the cover (12). Spool (33) should be on the side with the orifice (11), and with the slotted side to the outside.
18. Install spring (34) and plug (35) with O-ring (29) on this side.
19. Install O-rings (40) on fitting (41). Install piston (42) in bore of body (39). Install fitting (41) on body (39) and install assembly in cover (12).
20. Install O-rings (44) and (45) on vent post (46). Install vent post in cover. Install spring (47) and shoe (48) on vent post.
21. Place two spring washers (49), nested with the bent sections matching each other, into the large hole in the servo link.
22. Place washer (55) against the spring washers.
23. Install O-ring (7) into groove in the remaining shear seal (50). Note: This shear seal does not contain the two .094" (2.4 mm) radius scallops in the face. Place on top of washer (55). Position shear seal to match the lip on the servo link.
24. For 4C controls, install adjusting screws (2), nuts (3) O-rings (30), plugs (34) and O-rings (33) into plugs (29).
25. Install control over dowels, with gasket, (51), washers (3) and screws (2). Torque to 30 lbs-ft. (40.8 Nm).
26. Install bypass tubing lines.

**TEST**

Install a needle valve on the bypass valve exhaust port, connected to tank. Close the valve.

Install a 1000 psi (70 bar) gage in the brake port.

1. Start prime mover and adjust compensator for 1000 psi (345 bar).
2. Turn centering trimmer screw to place input shaft on the zero stroke position. Stroke pump towards full and release, on both sides of center. Pump shall return to zero stroke within 200 psi (13.8 bar) max.
3. For 4C controls, unload pump, set maximum volume stops to full displacement.
4. Load pump. Stroke pump CW. The gage on the brake port should start to indicate servo pressure when the system pressure is between 2000 and 4500 psi (138 and 310 bar), with an increasing signal, and must return to case pressure before system pressure drops to 2000 psi (138 bar), on decreasing signal. Repeat by rotating input shaft CCW. If pressures are incorrect remove piston assembly containing the adjustment screw, to change ball gap setting. Extend adjustment to increase pressures, retract to reduce pressures. Standard setting is .012" (0.305 mm) gap, which is 3/8 turn of adjustment beyond closed position.
5. When finished adjusting, record both pressures for each rotation of the servo input shaft.
6. Open the needle valve on the neutral bypass port. Measure and record leakage from this port with the pump on center at minimum psi, and with the pump off center, at 5000 psi (345 bar).

**Maximum leakage with control on center:**

2.0 gpm (7.6 l/m)

**Minimum leakage with control on center:**

1.0 gpm (3.8 l/m)

**Maximum leakage with control off center:**

35 cu. in/min or .15 gpm (574 cm<sup>3</sup>/min. or 0.57 l/m)

7. Unload pump. Stroke pump above and below center. Control should operate smoothly. Brake pressure should drop to case pressure each time control is on center, and it should indicate servo pressure as soon as input shaft is rotated CW or CCW from center, per step 4 above.
8. Release control when pump is off center. Pump should return to center
9. Remove needle valve from bypass exhaust port and install exhaust line.

**PARTS LIST**

For Figure 4C - Rotary servo with  
brake and bypass valve

S23-12343 - 4B\* Fixed stops

S23-12324 - 4C\* Adjustable max. stops

ITEM	DESCRIPTION	PART NO.	QTY. 4B*	QTY. 4C*
1	Servo shaft assembly	S13-48438	1	1
2	Screw, hwhd. 3/8-16 x 1 1/4	353-25018	4	4
3	Washer, Nyltite #37	631-45007	4	4
4	Retaining ring, WT 5100-50	356-65070	1	1
5	O-ring, 70 S-1 ARP 013	671-00013	1	1
6	Plug 2HP5N-S	488-35046	-	1
7	O-ring, 70 S-1 ARP 017	671-00017	2	2
8	Shear seal	033-71371	1	1
9	Needle bearing	230-82141	1	1
10	Orifice, .028" (.71 mm), 1/16 PT	037-19104	1	1
11	Orifice plug	033-71437	2	2
12	Control cover	033-91110	1	1
13	Lee Pluget	447-00017	1	1
14	1/8" Hex flush plug	431-90204	7	7
15	Pin	033-71003	1	1
16	Center trim screw	033-91042	1	1
17	Spring pin 1/8 x 3/8	325-08060	2	2
18	Hex nut	033-91041	1	1
19	O-ring, 70 S-1 ARP 015	671-00015	1	1
20	Seat insert	033-71001	1	1
21	Threaded insert	033-71000	1	1
22	Spool	033-70839	2	2
23	Ball, 3/16"	201-06001	1	1
24	Adjustment screw	033-71113	1	1
25	Soc setscrew, 6-32 x 1/4	311-06042	1	1
26	Piston	033-70835	2	2
27	Compression spring	225-92040	2	2
28	Plug	033-70840	2	-
	Plug, threaded	033-70841	-	2
29	O-ring, 90 S-1 ARP 906	691-00906	3	3
30	Soc setscrew, 10-32 x 1"	312-35040	2	2
31	Cover nut, #10-32	033-91040	2	2
32	O-ring, 70 S-1 ARP 010	671-00010	-	2
33	Spool	033-70999	1	1
34	Spring	033-71112	1	1
35	Plug, 6P5ON-S	488-35003	1	1
36	Spool	033-70997	1	1
37	Spring	033-70992	1	1
38	Dowel pin, 1/8 x 1/2	324-20808	1	1
39	Body	033-91090	1	1
40	O-ring, 90 S-1 ARP 016	691-00016	2	2
41	Fitting	033-70998	1	1
42	Piston	033-70993	1	1
43	Spring pin, 3/16 x 3/4	325-12120	2	2
44	O-ring, 90 S-1 ARP 902	691-00902	1	3
45	O-ring, 70 S-1 ARP 006	671-00006	1	1
46	Vent post	033-70995	1	1
47	Compression spring	225-92044	1	1
48	Shoe	033-70996	1	1
49	Finger spring washer	350-10067	2	2
50	Shear seal	033-70525	1	1
51	Control gasket	033-91058	1	1
52	O-ring, 90 S-1 ARP 905	691-00905	1	1
53	Plug, 5HP5N-S	488-35020	1	1
54	Washer	350-10141	1	1
55	Thrust washer	350-10064	1	1
56	Plug, 2P5N-S	488-35029	-	1

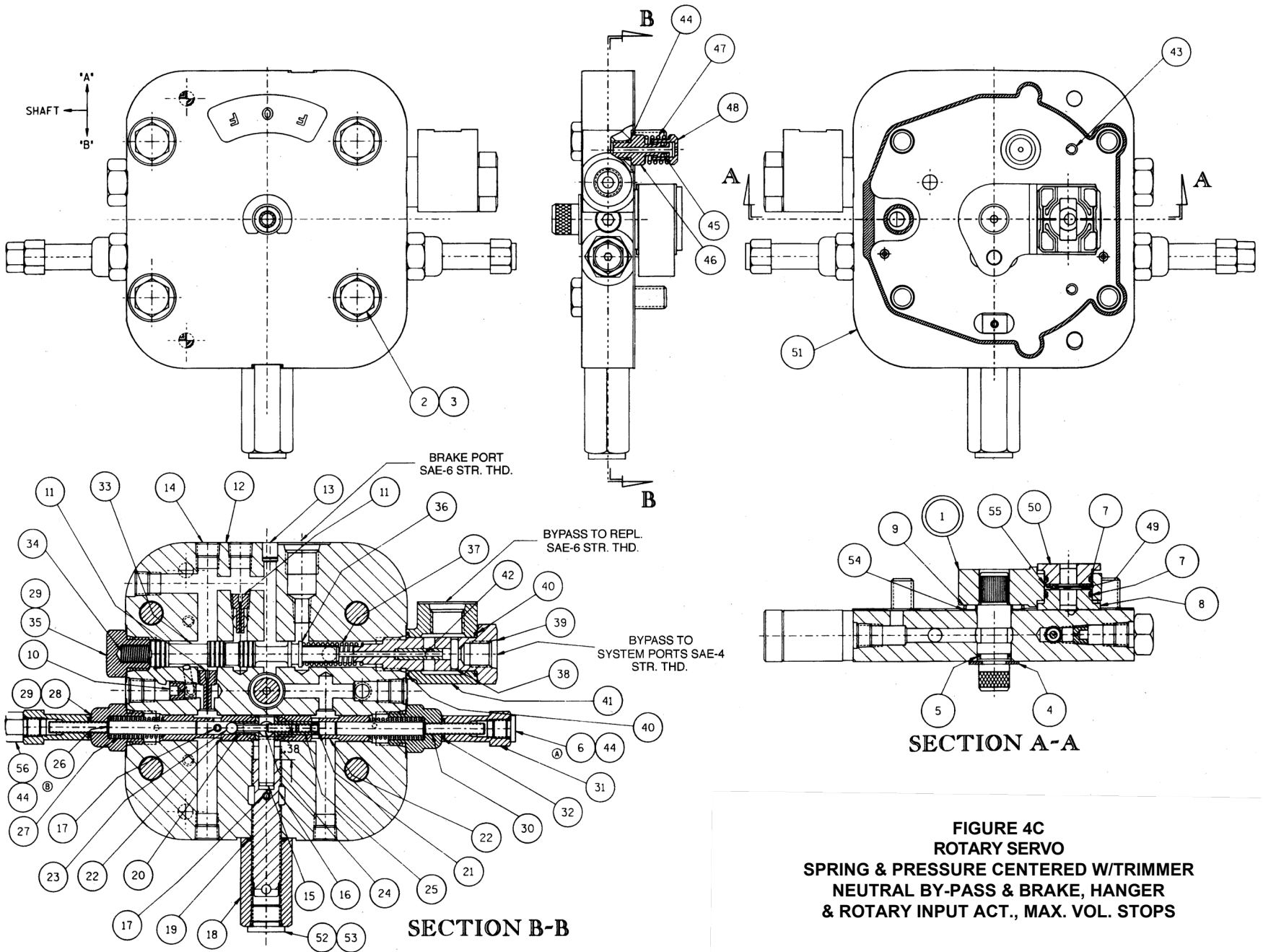

**FIGURE 4C**  
**ROTARY SERVO**  
**SPRING & PRESSURE CENTERED W/TRIMMER**  
**NEUTRAL BY-PASS & BRAKE, HANGER**  
**& ROTARY INPUT ACT., MAX. VOL. STOPS**

## CODE 5A - ELECTRIC STROKER

*S23-12413 - 5A\* 00 (with deadband)*

*S23-12415 - 5A\* 01 (no deadband)*

*S23-12419 - 5A\* - A Mig., Motor*

*S23-12418 - 5A\* - B Mig., Motor*

### DESCRIPTION

This control is used on both pumps and motors. The rotary servo input shaft is actuated by a hydraulic spool. A jet pipe is directed to two receiver orifices connecting to opposite ends of the hydraulic spool. The jet pipe is mechanically centered by a null adjust spring opposed by a feedback spring linked to spool position. A "voice coil" attached to the jet pipe creates an unbalance force in proportion to electrical current magnitude and direction. This causes the jet pipe to offset, increasing pressure on the one receiver and lowering pressure on the other receiver. The hydraulic spool responds causing the feedback spring to oppose the force, until the jet pipe is again centered at a new position of the servo.

When servo pressure to the jet pipe is blocked, the rotary servo spring centers and may be manually positioned.

Motor controls are configured to be offset to full stroke with zero signal, and 1/3 stroke with full signal. A spring in the rotary servo body biases the control to this position.

Cross center pump controls come in two versions. One version (feature 00) requires a small signal (deadband) prior to commencing stroke in either direction. The feature 01 control has no deadband.

**Note: This control is precision manufactured and requires training to properly assemble or disassemble. Unless repair parts and factory trained personnel are available, service should be limited to null adjustment.**

### NULL ADJUSTMENT:

If control functions over its full range, but pump remains on stroke when there is no electrical signal, adjustment of null position is indicated.

1. Load pump. Set compensator to 1000 psi (69 bar). Shut off external servo supply to control.
2. If system contains a shuttle valve, disable the shuttle valve as follows: If shuttle is on the pump, turn the shuttle relief adjustment two turns in. If it is a Denison shuttle mounted on the motor, remove shuttle and plug the two threaded ports with 3/8-24 setscrews. Re-install the valve.
3. Adjust and lock the trimmer for minimum system pressure on both ports. Connect a handle to the .375" (9.52 mm) dia. shaft extension on the stroker. Stroke the pump both sides of center. Do not exceed 100 lbs-in. (11.3 Nm) torque. Observe pressures on system ports when handle is released. Continue adjustment till pressure on either side is less than 150 psi (10.3 bar) difference.
4. To set jet pipe null adjustment, disconnect electrical signal and open servo oil supply to stroker. (200 psi min., 1000 psi max.) (14 bar min., 69 bar max.). For pump controls with deadband, rotate the jet pipe null adjustment CCW and CW to develop 700 psi (48 bar) on each system port. **Caution: always begin adjustment by backing out (CCW) on the jet pipe null adjustment and observing control reaction. Overadjusting clockwise direction can damage the jet pipe or the trimmer spring.** Set and lock the screw midway between these two limits. Torque to 10 lbs-in. (1.1 Nm) max. Install O-ring and cover nut.
5. For pump controls with no deadband, set and lock the jet pipe null adjustment at the point of minimum system pressure on both ports with pump at operating temperature.
6. For motor controls, set and lock the jet pipe null adjustment to just before the control commences to destroke.
7. Connect electrical signal and zero the electrical driver "zero adjustment".
8. Restore shuttle valve and system pressure settings to original operating conditions.

### PROCEDURE FOR CLEANING FILTER

See Figure 5A

A screen in the servo inlet line to the stroker prevents particles from getting into the jet pipe which might plug the jet pipe. In older models, this screen is behind the plug, (13). Field service is not recommended, as contaminants are on the outside, and could become dislodged in the servo body upon removal. In later models the screen is behind the fitting supplying servo oil to the stroker, and contaminants are lodged inside. With caution, it is possible to clean this filter as follows:

1. Disconnect servo tube line. Remove control from pump.
2. Remove plug (13).
3. Blow filtered air into the opening under the plug. Note if air escapes from the servo connection.
4. Force filtered oil or a compatible solvent through the opening to flush contaminants from the screen and out the servo inlet connection.

5. Carefully remove the filter without dislodging dirt into the opening. In recent controls, this filter is retained by a drilled hex plug. Backflush as before by forcing filtered oil into the port behind plug (13). Clean and install filter.
6. Examine surface of control cover for excess scratching. Examine shear seal for contamination in balance pads or deep scratches. Stone lightly to remove raised burrs and dings. Check that grooves supplying servo oil to balance pads are open.

See Figure 5A-1 or Figure 5A-2

7. Place two spring washers (1-6), nested with the bent sections matching each other, into the large hole in the servo link.
8. Place washer (1-10) against the spring washers.
9. Install O-ring (1-8) into groove in the shear seal (1-7). Install shear seal. Place on top of washer, (1-10). Position shear seal to match the lip on the servo link.
10. If control is to be tested on unit, install on control pad with new gasket and new Nyltite washers under screws. Torque to 30 lbs- ft. (40.8 Nm). Connect servo line and electrical connector to stroker.

## TEST, PUMP CONTROL

1. With servo pressure applied, bleed air from force motor by loosening the screws holding the electrical connector to the cap. If force motor faces down, bleed air from the stroke limiting screws. Command stroker back and forth to assure that all air is purged from the stroke piston, and stroker is functioning properly.
2. Set compensator to 1000 psi (69 bar). Block pump outlet lines. Shut off external servo supply to control.
3. If system contains a shuttle valve, disable the shuttle valve as follows: If shuttle is on the pump, turn the shuttle relief adjustment two turns in. If system contains a Denison shuttle mounted on the motor, remove shuttle and plug the two threaded ports with 3/8-24 setscrews. Re-install the valve.
4. Adjust and lock the mechanical trimmer for minimum system pressure on both ports. Connect a handle to the .375" (9.52 mm) dia. shaft extension on the stroker. Stroke the pump both sides of center. Do not exceed 100 lbs-in. (11.3 Nm) torque. Release handle and observe pressures on system ports. Continue adjustment till pressure is less than 150 psi (10.3 bar) difference on either side.
5. **For controls with deadband, (feature 00).** To set jet pipe null adjustment, disconnect electrical signal and supply servo oil to stroker. (200 psi min., 1000 psi max.) (14 bar min., 69 bar max.). Rotate the jet pipe null adjustment CCW and CW to develop 700 psi (48 bar) on each system port. **Caution: always begin adjustment by backing out (CCW) on the jet pipe null adjustment and observing control reaction. Overadjusting clockwise direction can damage the jet pipe or the trimmer spring.** Set the screw midway between these two limits and lock. Torque to 10 lbs-in. (1.1 Nm) max. Install O-ring and cover nut.
6. Reconnect electrical signal and zero the electrical driver "zero adjustment" for minimum pressure.
7. Stroke to full displacement. Turn in maximum stroke stop till pump just commences reducing stroke. Lock in this position. Repeat with current of opposite polarity
8. Slowly apply current to the valve. Note the value of current at which pressure starts to build (e.g. +40MA). Back off current and slowly apply the opposite polarity current to the valve. Note the value of current at which pressure builds the opposite side of center (e.g. -50MA). The sum of the absolute values must be between 50 and 100 MA (e.g. 40 + 50=90MA), and the difference between the two absolute values must be less than 20MA. (e.g. 50 - 40=10MA). If not within specification, readjust jet pipe null.
9. **For controls with no deadband, (feature 01),** disconnect the electrical connector, supply servo oil to the control. Set and lock the jet pipe null adjustment at the point of minimum system pressure on both ports with pump at operating temperature. Torque to 10 lbs-in. (1.1 Nm) max. **Caution: always begin adjustment by backing out (CCW) on the jet pipe null adjustment and observing control reaction. Overadjusting clockwise direction can damage the jet pipe or the trimmer spring.** Install O-ring and cover nut.
10. **For all controls,** apply 330MA to the control. The pump should go to full displacement. With the "A" terminal positive, control shaft should rotate CCW. Repeat for opposite side.
11. With pump at full displacement, block the servo supply to the stroker, The pump should spring center within 3 seconds.
12. Check for smooth change in displacement with gradual increase and decrease of control signal.
13. Restore shuttle valve and system pressure settings to original operating conditions.

## TEST, MOTOR CONTROL

1. With servo pressure applied, bleed air from stroker force motor by loosening the screws holding the electrical connector to the cap. If force motor faces down, bleed air from the stroke limiting screws. Command stroker back and forth to assure that all air is purged from the stroke piston, and stroker is functioning properly.
2. With motor running at low speed and servo supply shut off, turn in maximum stop

screw till motor just commences to reduce stroke (increase speed). Lock in this position.

3. Open servo supply (200 psi min, 1000 psi max.) (14 bar min. 69 bar max.) and apply current (330 ma Max.), polarity to cause reduced stroke. Adjust minimum stroke screw for 1/3 stroke. (speed increased to three times initial speed) Lock in this position.

4. With motor at 1/3 stroke, shut off servo supply. Motor shall return to full stroke in 3 seconds max..

5. To set jet pipe null adjustment, disconnect electrical connector. Open servo supply. Rotate the jet pipe null adjustment CCW and CW. Set and lock at the point just before the stoker begins to reduce stroke (increase speed). Torque to 10 lbs-in. (1.1 Nm) max **Caution: always begin adjustment by backing out (CCW) on the jet pipe null adjustment and observing control reaction. Over-adjusting clockwise direction can damage the jet pipe or the trimmer spring.** Install O-ring and cover nut.

6. Re-connect electrical signal and zero the "zero adjustment".

7. Apply 330MA to the control. The motor should go to 1/3 displacement. With the "A" terminal positive, control shaft should rotate CCW, and vice versa.

8. Check for smooth change in displacement with gradual increase and decrease of control signal.

**PARTS LIST**

For Figure 5A Electric stroker

**PUMP CONTROLS**

S23-12413 - 5A\* 00 (With Deadband)

S23-12415 - 5A\* 01 (No Deadband)

**MOTOR CONTROLS**

S23-12419 - 5A\* A Mtg.

S23-12418 - 5A\* B Mtg.

			Feature →	00 Pump	01 Pump	A Mtg. Motor	B Mtg. Motor
ITEM	DESCRIPTION	PART NO.	QTY.	QTY.	QTY.	QTY.	
1	Rotary servo (Fig. 5A-1)	S23-12346	1	1	-	-	
	Rotary servo (Fig. 5A-2)	S23-12540	-	-	1	-	
	Rotary servo	S23-12539	-	-	-	1	
2	Cover nut 1/4-28	033-91038	2	2	2	2	
3	Screw, SHC 1/4-28 x1	312-11160	2	2	1	1	
4	O-ring, 70 S-5 ARP 011	675-00011	2	2	2	2	
5	Screw, SHC 1/4-20 x 3/4	358-12120	8	8	8	8	
6	Body-EH Stroker	033-72117	1	1	1	1	
7	Spool	033-53439	1	1	1	1	
8	Pluget, Lee	447-00017	2	2	2	2	
9	Gasket	033-72109	2	2	2	2	
10	Cover plate	033-54538	2	2	2	2	
11	Screw, SHC 5/16-18 x 1 1/4	358-14180	2	2	2	2	
12	O-ring, 70 S-5 ARP 012	675-00012	2	2	2	2	
13	Plug, 4HP5N-S	488-35061	1	1	1	1	
14	O-ring, 90 S-5 ARP 904	695-00904	1	1	1	1	
15	Plug, 2HP5N-S	488-35046	2	2	2	2	
16	Screw, SHC, 10-24 x 5/8	358-10100	1	-	-	-	
	Screw, SHC, 10-24 x 1/2	358-10080	-	1	1	1	
17	Bearing, 3/8 x 9/16 x 1/2	230-82174	1	-	-	-	
	Bearing, 3/8 x 9/16 x 5/8	230-00610	-	1	1	1	
18	O-ring, 70 S-5 ARP 110	675-00110	1	1	1	1	
19	Clamp	033-53688	1	-	-	-	
20	O-ring, 90 S-5 ARP 902	695-00902	2	2	2	2	
21	Pin	033-53894	1	1	1	1	
22	Link, control	033-53687	1	-	-	-	
	Clamp	033-72111	-	1	1	1	
23	Bushing	033-72112	1	1	1	1	
24	O-ring 70 S-5 ARP 017	675-00017	1	1	1	1	
25	Dowel pin, 1/8 x 1/2	324-20808	1	-	-	-	
26	Dowel pin, 3/16 x 1/2	324-21208	1	1	1	1	
27	Tubing, servo control	S23-12939	1	1	1	1	
28	Connector, 4-F5BX-S	493-15027	1	1	1	1	
29	Screw	033-91103	1	1	1	1	
30	Filter element	033-91104	1	1	1	1	
31	Screw, SHC 1/4-28 x 1 1/2	312-11200	-	-	1	1	
32	Fitting, swivel nut elbow	496-15009	1	1	1	1	
33	Force motor	S13-46096	1	1	1	1	
34	Nameplate	033-91430	1	1	1	1	
35	Screw, HWHD 3/8-16 x 1 1/4	353-25018	4	4	4	4	
36	Washer, Nyltite #37	631-45007	4	4	4	4	
37	Drive screw,#2 x 3/16	320-10203	4	4	4	4	

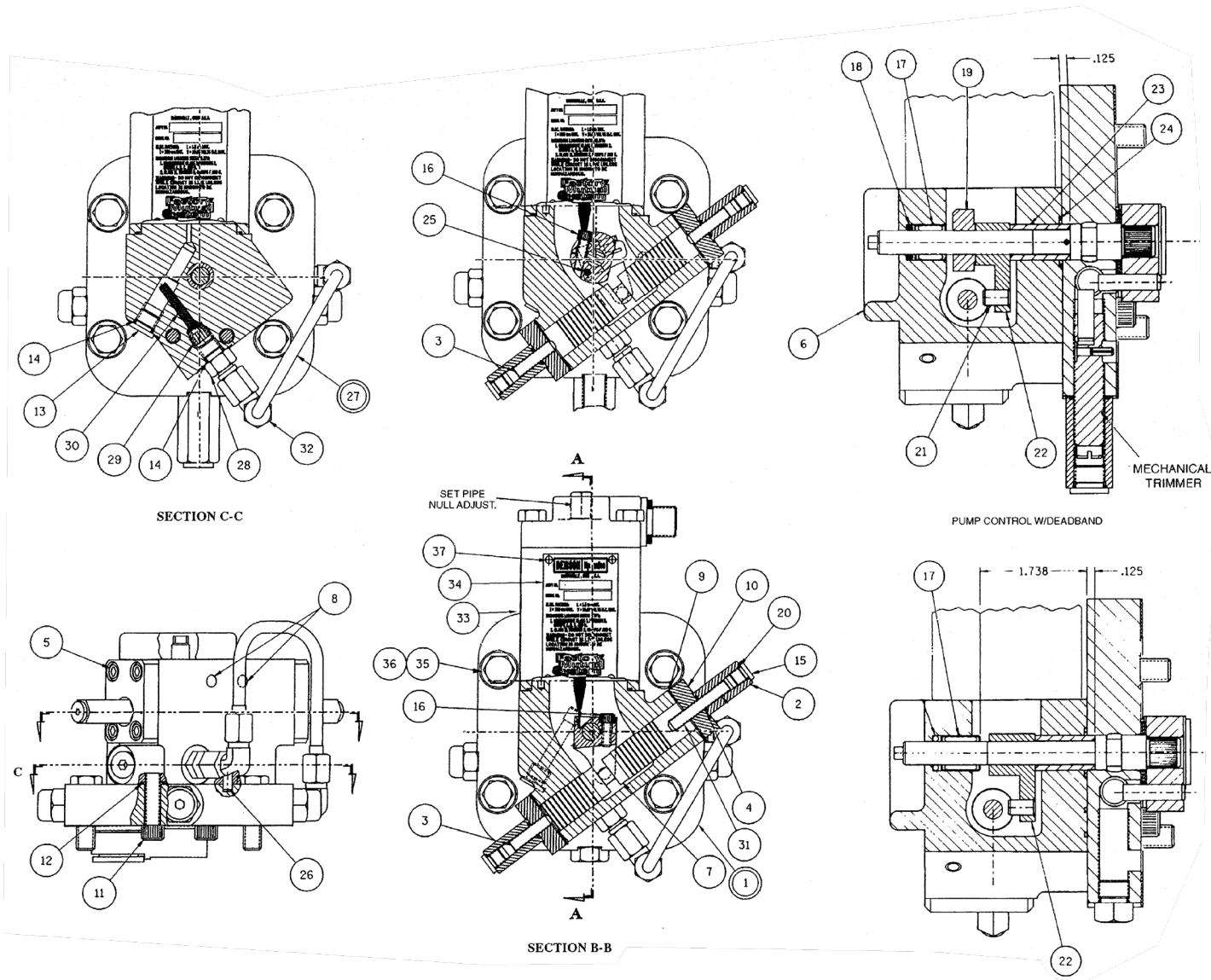

**FIGURE 5A**  
**ELECTRIC STROKER**  
**MOTOR CONTROL "O" DEAD BAND**  
**"A" MTG. SHOWN**  
**REVERSE ITEMS 3, 31 FOR "B" MTG.**

**PARTS LIST**

For Figure 5A-1 - Servo for electric stroker - pump

S23-12346

Rotary servo for pump electric stroker

ITEM	DESCRIPTION	PART NO.	QTY.
1	Servo shaft, link & shear seal	S23-12497	(1)
1-1	Servo shaft	033-54841	1
1-2	Pin	033-71002	1
1-3	Servo link	033-70536	1
1-4	Washer	350-10141	1
1-5	Shear seal, feed	033-71371	1
1-6	Washer, finger spring	350-10067	2
1-7	Shear seal	033-70525	1
1-8	O-ring, 70 S-5 ARP 017	675-00017	2
1-9	Needle bearing	230-82141	1
1-10	Thrust washer	350-10064	1
2	O-ring, 90 S-5 ARP 905	695-00905	1
3	Plug, 5-HP5N-S	488-35020	1
7	Gasket	033-91058	1
9	Cover plate	033-72114	1
12	Plug	033-70840	2
13	O-ring, 90 S-5 ARP 906	695-00906	2
14	Spring	033-72181	2
15	Spool, short	033-72180	2
16	Fitting, male elbow	473-15042	1
17	O-ring, 70 S-5 ARP 015	675-00015	1
18	Screw, center trim	033-91042	1
19	Nut	033-91041	1
20	Spring pin 1/8 x 3/8	325-08060	1
21	Pin	033-71003	1

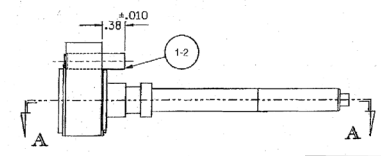
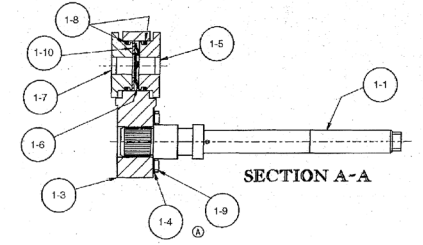
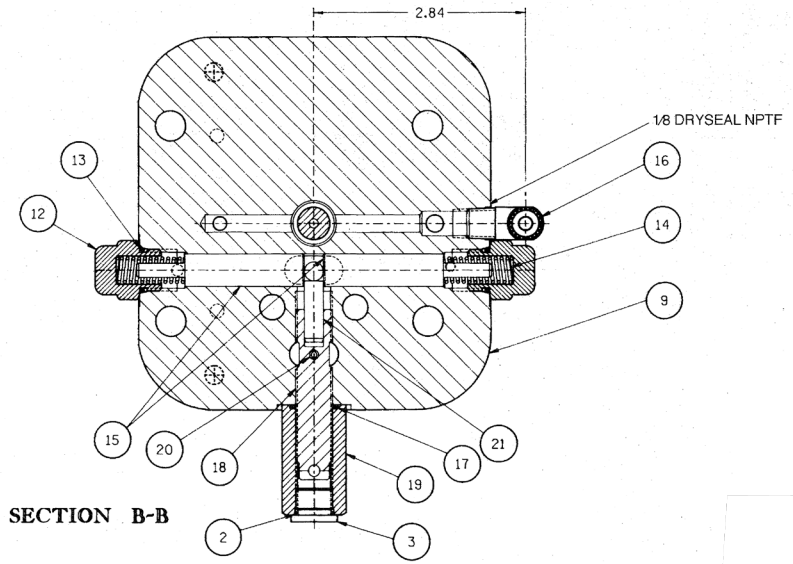
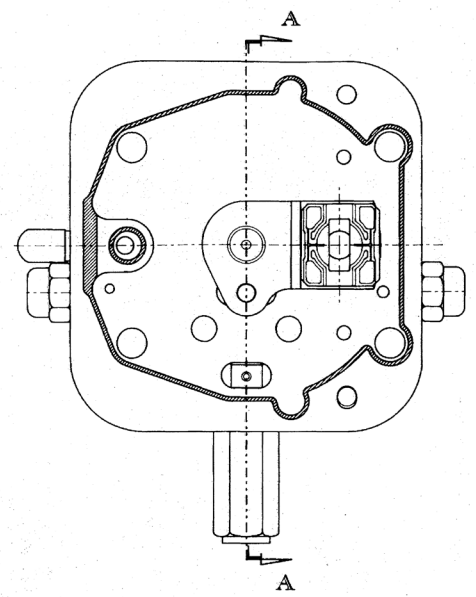
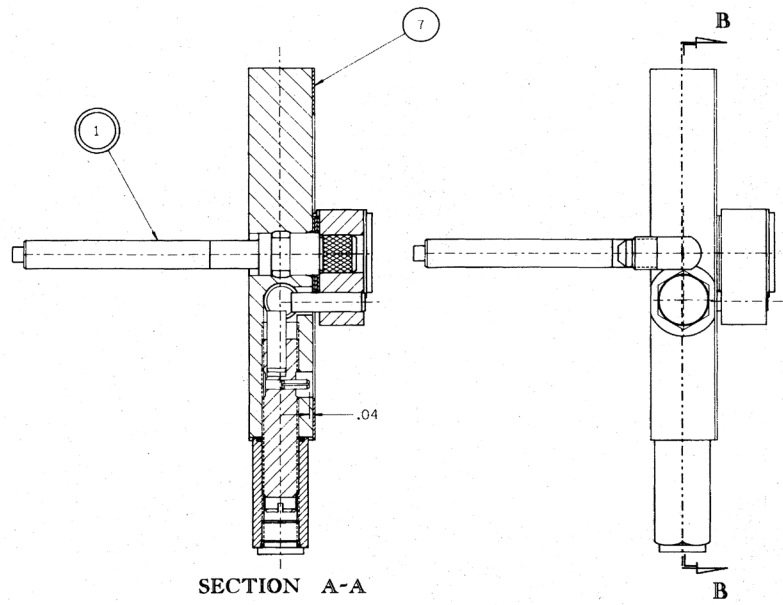

**FIGURE 5A-1**  
**CONTROL ROTARY SERVO FOR HYD. STROKER**  
**SPRING CENTERED WITH TRIMMER**

S23-12346

**PARTS LIST**

*For Figure 5A-2 - Servo for electric stroker- motor*

*S23-12540 - 5A\* A Mtg.*

*23-12539 - 5A\* B Mtg.*

*Rotary servo for motor electric stroker*

ITEM	DESCRIPTION	PART NO.	QTY.
1	Servo shaft, link & shear seal	S23-12497	(1)
1-1	Servo shaft	033-54841	1
1-2	Pin	033-71002	1
1-3	Servo link	033-70536	1
1-4	Washer	350-10141	1
1-5	Shear seal, feed	033-71371	1
1-6	Washer, finger spring	350-10067	2
1-7	Shear seal	033-70525	1
1-8	O-ring, 70 S-5 ARP 017	675-00017	2
1-9	Needle bearing	230-82141	1
1-10	Thrust washer	350-10064	1
2	Gasket	033-91058	1
3	Cover plate	033-72114	1
4	Spool, short	033-72180	1
5	Plug	033-70840	2
6	O-ring, 90 S-5 ARP 906	695-00906	2
7	Spring	033-72181	1
8	Spool, long	033-70844	1
9	Fitting, male elbow	473-15042	1
10	Plug, 5-P5N-S	488-35028	1
11	O-ring, 90 S-5 ARP 905	695-00905	1

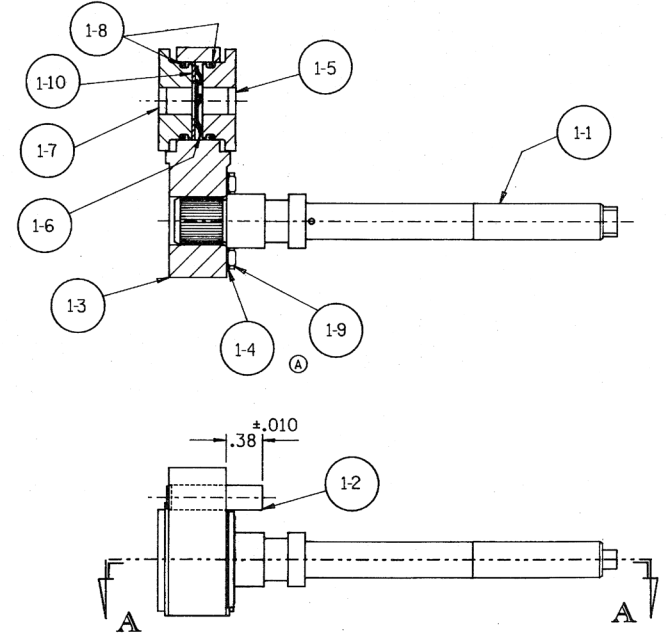
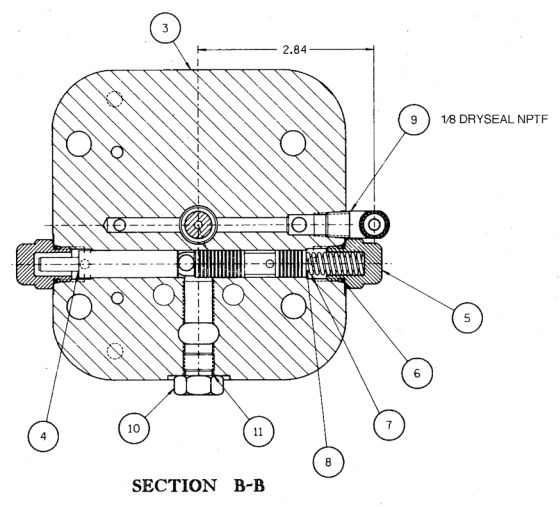
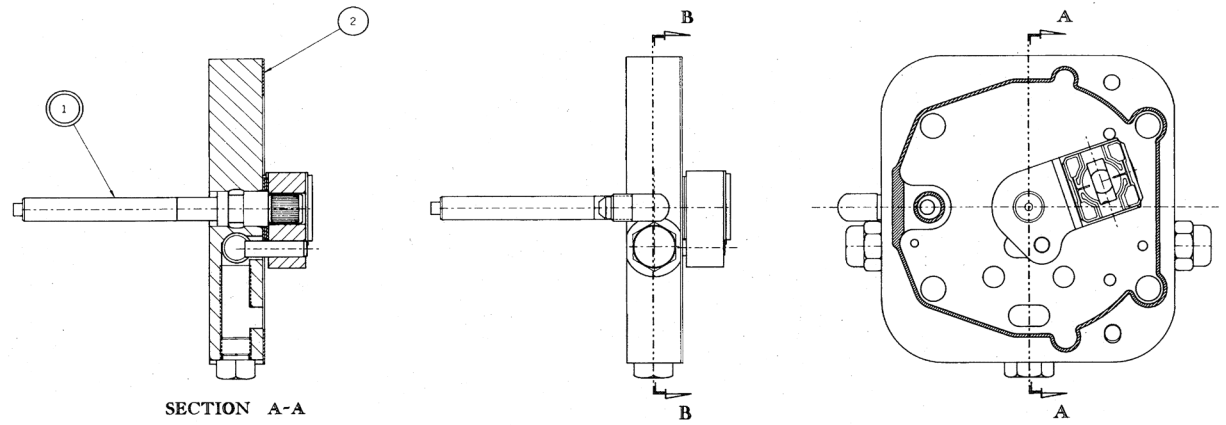

**FIGURE 5A-2**  
**ASSEMBLY ROTARY SERVO,**  
**SPRING OFF-SET, ELEC/HYD. CONTROL;**  
**A SIDE INPUT, REVERSE ASSEMBLY OF**  
**4, 7, 8 FOR B SIDE INPUT**

## CODE 5C - ELECTRIC STROKER WITH BRAKE AND BYPASS

S23-12414 - 5C\* 00 (With Deadband)

S23-12420 - 5C\* 01 (No Deadband)

### DESCRIPTION

This control is used on pumps. The rotary servo input shaft is actuated by a hydraulic spool. A jet pipe is directed to two receiver orifices connecting to opposite ends of the hydraulic spool. The jet pipe is mechanically centered by a null adjust spring opposed by a feedback spring linked to spool position. A "voice coil" attached to the jet pipe creates an unbalance force in proportion to electrical current magnitude and direction. This causes the jet pipe to offset, increasing pressure on the one receiver and lowering pressure on the other receiver. The hydraulic spool responds causing the feedback spring to oppose the force, until the jet pipe is again centered at a new position of the servo.

When servo pressure to the jet pipe is blocked, the rotary servo spring centers, and may be manually positioned.

One version of the cross center control requires a small signal (deadband) prior to commencing stroke in either direction. This control contains spring centering pistons and neutral trimmer adjustment for accurate centering. Another version, (no deadband) provides linear displacement with input command for accurate servo applications.

In the control cover is contained the brake and bypass valve option. A brake spool, when energized, connects the brake port to servo pressure. When de-energized, a spring shifts the spool, connecting the brake port to tank. Another port, located on the end of the brake valve, is closed by the energizing of the brake spool. When de-energized, this port dumps both pump system ports to the replenishing source, thus bypassing the small flow generated by slight errors on zero position.

The operation is controlled in this manner: A restricted servo flow is applied to shift the brake spool. This flow is dumped when a slot in the servo plate aligns with a passage connecting to this spool. This occurs when the pump is on zero stroke. Another restricted flow is applied to a spool adjacent to the brake spool. This flow is also connected to a passage in one centering piston, containing a ball and seat. When the control is off center, the ball seats, sealing the passage, to apply servo pressure to the spool. When the control is on center, a pin extending from the other centering piston pushes the ball off the seat, to dump the flow.

The brake spool is thus de-energized to set the brake when BOTH the pump cam is at zero stroke and the rotary servo is at zero command. If the pump is on stroke or the input is on stroke, the brake spool is energized, releasing the brake.

### DISASSEMBLY

See Figure 5C

**Note: This control is precision manufactured and requires training to properly assemble or disassemble. Unless repair parts and factory trained personnel are available, service should be limited to the brake and bypass portion, and null adjustment**

### NULL ADJUSTMENT:

If control functions over its full range, but pump remains on stroke when there is no electrical signal, adjustment of null position is indicated.

1. Load pump. Set compensator to 1000 psi (69 bar). Shut off external servo supply to control.
2. If system contains a shuttle valve, disable the shuttle valve as follows: If shuttle is on the pump, turn the shuttle relief adjustment two turns in. If it is a Denison shuttle mounted on the motor, remove shuttle and plug the two threaded ports with 3/8-24 setscrews. Re-install the valve.
3. Adjust and lock the trimmer for minimum system pressure on both ports. Connect a handle to the .375" (9.52 mm) dia. shaft extension on the stroker. Stroke the pump both sides of center. Do not exceed 100 lbs-in. (11.3 Nm) torque. Observe pressures on system ports when handle is released. Continue adjustment till pressure on either side is less than 150 psi (10.3 bar) difference.
4. To set jet pipe null adjustment, disconnect electrical signal and open servo oil supply to stroker. (200 psi min, 1000 psi max.) (14 bar min. 69 bar max.). For pump controls with deadband, rotate the jet pipe null adjustment CCW and CW to develop 700 psi (48 bar) on each system port. **Caution: always begin adjustment by backing out (CCW) on the jet pipe null adjustment and observing control reaction. Overadjusting clockwise direction can damage the jet pipe or the trimmer spring.** Set and lock the screw midway between these two limits. Torque to 10 lbs-in. (1.1 Nm) max. Install O-ring and cover nut.
5. For pump controls with no deadband, set and lock the jet pipe null adjustment at the point of minimum system pressure on both ports with pump at operating temperature.

6. Connect electrical signal and zero the electrical driver "zero adjustment".
7. Restore shuttle valve and system pressure settings to original operating conditions.

**PROCEDURE FOR CLEANING FILTER**

A screen in the servo inlet line to the stroker prevents particles from getting into the jet pipe which might plug the jet pipe. In older versions, this screen is behind the plug, (13). Field service is not recommended, as contaminants are on the outside, and could become dislodged in the servo body upon removal. In later versions the screen is behind the fitting supplying servo oil to the stroker, and contaminants are lodged inside. With caution, it is possible to clean this filter as follows:

1. Disconnect servo tube line. Remove control from pump.
2. Remove plug (13).
3. Blow filtered air into the opening under the plug. Observe for air from the servo connection.
4. Force filtered oil or a compatible solvent through the opening to flush contaminants from the screen and out the servo inlet connection.
5. Carefully remove the filter without dislodging dirt into the opening. In latest version, this filter is retained by a drilled hex plug. Backflush as before by forcing filtered oil into the port behind plug (13). Clean and install filter.
6. Examine surface of control cover for excess scratching. Examine shear seal for contamination in balance pads or deep scratches. Stone lightly to remove raised burrs and dings. Check that grooves supplying servo oil to balance pads are open.
7. Place two spring washers (31-6), nested with the bent sections matching each other, into the large hole in the servo link.
8. Place washer (31-10) against the spring washers.
9. Install O-ring (31-8) into groove in the shear seal (31-7). Install shear seal Place on top of washer, (31-10). Position shear seal to match the lip on the servo link.
10. If control is to be tested on unit, install on control pad with new gasket and new Nyltite washers under screws. Torque to 30 lbs- ft. (40.8 Nm). Connect bypass tubing lines. Connect servo line and electrical connector to stroker.

**DISASSEMBLY OF BRAKE AND BYPASS PORTION**

See Figure 5C-1

1. Remove plugs (28). Remove springs (27), pistons (26), and spools (22), with attached parts. Do not disassemble unless parts are damaged. Examine spools, pistons and bores for free motion, wear or contamination.
2. If trimmer adjustment must be removed, carefully tap the spring pin (17) in till flush with O.D. of screw (16). Remove nut (18), and screw (16). Remove spring pin (17) from screw.
3. Remove bypass valve body (36) with fitting (38) piston (39) and spring (34). Remove plug (32) and spring (31). Remove spools (30) and (33).
4. Remove shoe (45), and spring (44).
5. Blow through passages to check two orifices (11) and orifice (10) in body for contamination. Check passages in body for free flow.

**PREPARATION FOR ASSEMBLY**

All parts are to be inspected and be free of material defects, dirt, scratches or any foreign material.  
 All parts are to be cleaned with a suitable cleaning solvent and all cores and passages blown out with clean dry compressed air.  
 After cleaning and inspection, all parts are to be covered with a light film of oil and should be protected from dirt and excessive handling until assembled onto the unit.  
 During assembly, lapped and ground surfaces should be kept lubricated and protected from nicks or surface damage.

**REWORK OF WEAR PARTS**

Description	Rework
Servo plate face	Fine stone to remove raised burrs & dings
Shear seal	Fine stone to remove raised burrs & dings. Note: grooves to supply balance pads must be present and adequate.
Control cover	Stone or lap inside face to remove raised burrs & dings.
Spool	Break sharp edges or dings.
Shoe	Stone to remove raised burrs or dings.

**ASSEMBLY**

See Figure 5C-1

1. Install orifices (10) and (11) in body. Torque to 25 lbs-in. (2.8 Nm). Make sure that the orifice (11) in the deeper bore extends past the wall of the valve bore and will not interfere with spool (33) or spool (22) action.
2. Apply pipe sealant and install plugs (14) in body. Torque to 100 lbs-in. (11.3 Nm)
3. Press pin (15) into screw (16) to 0.38" (9.65 mm) extended length.
4. Install screw (16) into body. Pin (15) should extend into spool bore approximately .090" (2.29 mm). The eccentric pin must be indexed so that it is offset towards the outside surface of the cover plate. The drilled hole for the spring pin (17) should be approximately centered in the slotted opening in the cover plate. Install spring pin (17) into trimmer assembly. Leave approximately one-half length of pin extending from

screw. This will allow approximately plus or minus 45° rotation of the trimmer assembly. Install nut (18) with O-ring (19), locking trimmer in position. Install O-ring (52) and plug (53).

5. Assemble seat insert (20) and threaded insert (21) into spools (22), using loctite #271 per instructions on bottle. Inserts must be assembled into the spool end nearest the 1/8" (3.18 mm) cross drilled holes.

6. When assembled spools (22) are installed in cover plate (12), they are held against the eccentric pin of the trimmer assembly by springs (27). In this position, adjusting screw (24) must have the ball (23) unseated by .012" (.305 mm) to cause brake release at 5% of stroke. A special fixture permits adjustment to this setting per AP-01925. In the absence of this fixture, drop ball (23) into the spool containing the seat insert. Hold the ball against the seat by inserting piston (26) into the bore. Hold the two spools (22) with inserts together and set the adjusting screw (24) to where it just contacts the ball. Turn the adjusting screw in 8 3/8 turns past this point and lock with setscrew (25), being careful not to disturb the setting.

7. Retain ball (23) in spool bore by installing spring pin (17). Make sure that the ends of the spring pin do not extend beyond the O.D. of the spool.

8. Install pistons (26) into the spools (22). Install spool assemblies in the bore containing the trimmer adjustment. The spool containing the ball is to be on the side with the orifice (11).

9. Install springs (27) over pistons. Install plugs (28) and O-rings (29).

10. Install spools (30) and (33) into the other cross-bore in the cover (12). Spool (30) should be on the side with the orifice (11), and with the slotted side to the outside.

11. Install spring (31) and plug (32) with O-ring (29) on this side.

12. Install O-rings (37) on fitting (38). Install piston (39) in bore of body (36). Install fitting (38) on body (36) and install assembly in cover (12).

13. Install O-rings (41) and (42) on vent post (43). Install vent post in cover. Install spring (44) and shoe (45) on vent post.

See Figure 5-C

14. Place two spring washers (31-6), nested with the bent sections matching each other, into the large hole in the servo link.

15. Place washer (31-4) against the spring washers.

16. Install O-ring (31-8) into groove in the remaining shear seal (31-7). Place on top of washer (31-4). Position shear seal to match the lip on the servo link.

17. Install control on pump over dowels, with gasket, washers (36) and screws (35). Torque to 30 lbs-ft. (40.8 Nm).

18. Install bypass tubing lines.

## TEST

Install a needle valve on the bypass valve exhaust port, connected to tank. Close the valve. Install a 1000 psi (70 bar) gage in the brake port.

1. With servo pressure applied, bleed air from force motor by loosening the screws holding the electrical connector to the cap. If force motor faces down, bleed air from the stroke limiting screws. Command stroker back and forth to assure that all air is purged from the stroke piston, and stroker is functioning properly.

2. Load pump. Set compensator to 1000 psi. Shut off external servo supply to control.

3. If system contains a shuttle valve, disable the shuttle valve as follows: If shuttle is on the pump, turn the shuttle relief adjustment two turns in. If it is a Denison shuttle mounted on the motor, remove shuttle and plug the two threaded ports with 3/8-24 setscrews. Re-install the valve.

4. Adjust and lock the trimmer for minimum system pressure on both ports. Connect a handle to the .375" (9.52 mm) dia. shaft extension on the stroker. Stroke the pump both sides of center. Do not exceed 100 lbs-in. (11.3 Nm) torque. Observe pressures on system ports. Continue adjustment till pressure on either side is less than 150 psi difference.

5. Disconnect electrical signal and open servo oil supply to stroker. (200 psi min, 1000 psi max.) (14 bar min. 69 bar max.).

6. **For controls with deadband (Feature 00)**, rotate the jet pipe null adjustment CCW and CW to develop 700 psi (48 bar) on each system port. **Caution: always begin adjustment by backing out (CCW) on the jet pipe null adjustment and observing control reaction. Overadjusting clockwise direction can damage the jet pipe or the trimmer spring.** Set the screw midway between these two limits and lock. Torque to 10 lbs-in. (1.1 Nm) max. Install O-ring and cover nut.

7. **For controls with no deadband**, set and lock the jet pipe null adjustment at the point of minimum system pressure on both ports with pump at operating temperature.

8. Reconnect electrical signal and zero the electrical driver "zero adjustment" for minimum pressure.

9. Unload pump. Stroke to full displacement. Turn in maximum stroke stop till pump just commences reducing stroke. Lock in this position. Repeat with current of opposite polarity

10. For controls with the 00 feature (deadband): Slowly apply current to the valve. Note the value of current at which pressure starts to build (e.g. +40MA). Back off cur

rent and slowly apply the opposite polarity current to the valve. Note the value of current at which pressure builds the opposite side of center (e.g. -50MA). The sum of the absolute values must be between 50 and 100 MA (e.g. 40 + 50=90MA), and the difference between the two absolute values must be less than 20MA. (e.g. 50 - 40=10MA). If not within specification, readjust jet pipe null.

For controls with the 01 feature (no deadband), there should be minimal hesitation as the control signal passes through zero.

11. Apply 330MA to the control. The pump should go to full displacement. Repeat for opposite side. With the "A" terminal positive, control shaft should rotate CCW.

12. With pump at full displacement, block the servo supply to the stroker. The pump should spring center within 3 seconds.

13. Check for smooth change in displacement with gradual increase and decrease of control signal.

14. Load pump. Stroke input shaft CW. The gage on the brake port should start to indicate servo pressure when the system pressure is between 2000 and 4500 psi (138 and 310 bar), with an increasing signal, and must return to case pressure before system pressure drops to 2000 psi (138 bar), on decreasing signal. Repeat by rotating input shaft CCW. If pressures are incorrect remove piston assembly containing the adjustment screw, to change ball gap setting. Extend adjustment to increase pressures, retract to reduce pressures. Standard setting is .012" (0.305 mm) gap, which is 3/8 turn of adjustment beyond closed position.

15. When finished adjusting, record both pressures for each rotation of the servo input shaft.

16. Open the needle valve on the neutral bypass port. Measure and record leakage from this port with the pump on center at minimum psi, and with the pump off center, at 5000 psi

**Maximum leakage with control on center:**

2.0 gpm (7.6 l/m)

**Minimum leakage with control on center:**

1.0 gpm (3.8 l/m)

**Maximum leakage with control off center:**

35 cu. in/min or .15 gpm (574 cm<sup>3</sup>/min. or 0.57 l/m)

17. Unload pump. Stroke pump above and below center. Control should operate smoothly. Brake pressure should drop to case pressure each time control is on center, and it should indicate servo pressure as soon as input shaft is rotated CW or CCW from center, per step 4 above.

18. Release control when pump is off center. Pump should return to center. Repeat several times in each direction and at different pressures from 200 to 5000 psi (13.8 to 345 bar).

19. Remove needle valve from bypass exhaust port and install exhaust line.

20. Restore shuttle valve and system pressure settings to original operating conditions.

**PARTS LIST**

For Figure 5C Electric stroker

S23-12414 - 5C\* 00 (With Deadband)

S23-12420 - 5C\* 01 (No Deadband)

		Feature →	00	01
ITEM	DESCRIPTION	PART NO.	QTY.	QTY.
1	Rotary servo (Fig. 5C-1)	S23-12347	1	1
2	Cover nut 1/4-28	033-91038	2	2
3	Screw, SHC 1/4-28 x1	312-11160	2	2
4	O-ring, 70 S-5 ARP 011	675-00011	2	2
5	Screw, SHC 1/4-20 x 3/4	358-12120	8	8
6	Body-EH Stroker	033-72117	1	1
7	Spool	033-53439	1	1
8	Pluget, Lee	447-00017	2	2
9	Gasket	033-72109	2	2
10	Cover plate	033-54538	2	2
11	Screw, SHC 5/16-18 x 1 1/4	358-14180	2	2
12	O-ring, 70 S-5 ARP 012	675-00012	2	2
13	Plug, 4HP5N-S	488-35061	1	1
14	O-ring, 90 S-5 ARP 904	695-00904	1	1
15	Plug, 2HP5N-S	488-35046	2	2
16	Screw, SHC, 10-24 x 5/8	358-10100	1	-
	Screw, SHC, 10-24 x 1/2	358-10080	-	1
17	Bearing, 3/8 x 9/16 x 1/2	230-82174	1	-
	Bearing, 3/8 x 9/16 x 5/8	230-00610	-	1
18	O-ring, 70 S-5 ARP 110	675-00110	1	1
19	Clamp	033-53688	1	-
20	O-ring, 90 S-5 ARP 902	695-00902	2	2
21	Pin	033-53894	1	1
22	Link, control	033-53687	1	-
	Clamp	033-72111	-	1
23	Bushing	033-72112	1	1
24	O-ring 70 S-5 ARP 017	675-00017	1	1
25	Dowel pin, 1/8 x 1/2	324-20808	1	-
26	Dowel pin, 3/16 x 1/2	324-21208	1	1
27	Tubing, servo control	S23-12938	1	1
28	Connector, 4-F5BX-S	493-15027	1	1
29	Screw	033-91103	1	1
30	Filter element	033-91104	1	1
31	Servo shaft, link & shear seal	S23-12497	(1)	(1)
31-1	Servo shaft	033-54841	1	1
31-2	Pin	033-71002	1	1
31-3	Servo link	033-70536	1	1
31-4	Washer	350-10141	1	1
31-5	Shear seal, feed	033-71371	1	1
31-6	Washer, finger spring	350-10067	2	2
31-7	Shear seal	033-70525	1	1
31-8	O-ring, 70 S-5 ARP 017	675-00017	2	2
31-9	Needle bearing	230-82141	1	1
31-10	Thrust washer	350-10064	1	1
32	Fitting, swivel nut elbow	496-15009	1	1
33	Force motor	S13-46096	1	1
34	Nameplate	033-91430	1	1
35	Screw, HWHD 3/8-16 x 1 1/4	353-25018	4	4
36	Washer, Nyltite #37	631-45007	4	4
37	Drive screw, #2 x 3/16	320-10203	4	4
38	Plug	449-00510	1	1

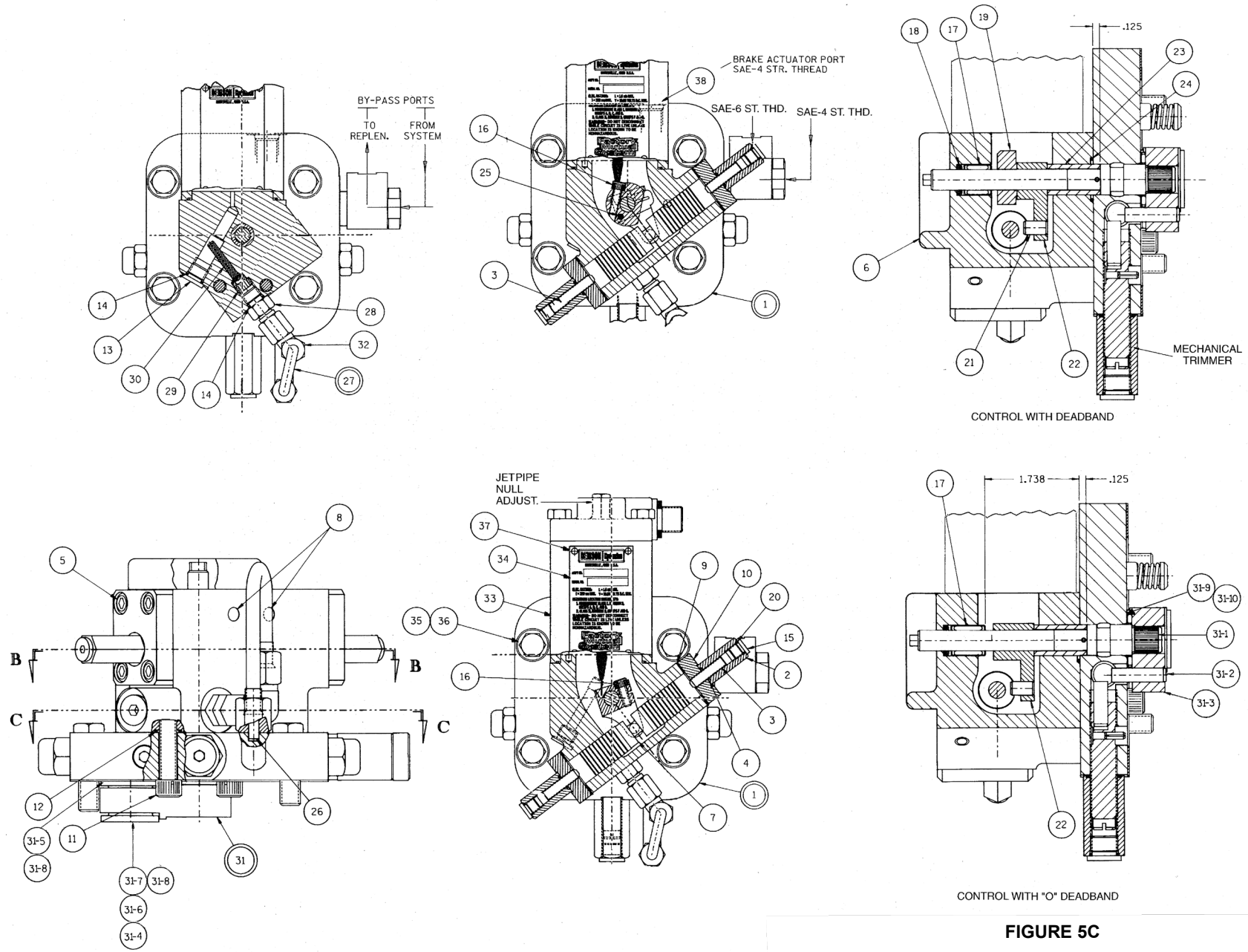

**PARTS LIST**

For Figure 5C-1 Brake and bypass valve for 5C control

S23-12347

ITEM	DESCRIPTION	PART NO.	QTY.
6	Gasket, control cover	033-91058	1
10	Orifice, .028" (0.71 mm), 1/16 PT	037-19104	1
11	Orifice plug	033-71437	2
12	Cover	033-91156	1
13	Lee Pluget	447-00017	1
14	1/8" Hex flush plug	431-90204	6
15	Pin	033-71003	1
16	Screw, center trim	033-91042	1
17	Spring pin, 1/8 x 3/8	325-08060	2
18	Nut	033-91041	1
19	O-ring, 70 S-5 ARP 015	675-00015	1
20	Seat - insert	033-71001	1
21	Insert - threaded	033-71000	1
22	Spool	033-70839	2
23	Ball, 3/16 DIA	201-06001	1
24	Screw, adjustment	033-71113	1
25	Soc. setscrew, 6-32 x 1/4	311-06042	1
26	Piston	033-70835	2
27	Spring	225-92040	2
28	Plug	033-70840	2
29	O-ring, 90 S-5 ARP 906	695-00906	3
30	Spool	033-70999	1
31	Spring	033-71112	1
32	Plug, 6P5ON-S	488-35003	1
33	Spool	033-70997	1
34	Spring	033-70992	1
35	Dowel pin, 1/8 x 1/2	324-20808	1
36	Body	033-91090	1
37	O-ring, 90 S-5 ARP 016	695-00016	2
38	Fitting	033-70998	1
39	Piston	033-70993	1
41	O-ring, 90 S-5 ARP 902	695-00902	1
42	O-ring, 70 S-5 ARP 006	675-00006	1
43	Vent post	033-70995	1
44	Compression spring	225-92044	1
45	Shoe	033-70996	1
52	O-ring, 90 S-5 ARP 905	695-00905	1
53	Plug, 5-P5N-S	488-35020	1
54	Fitting, XLG male elbow 37°	473-15043	1

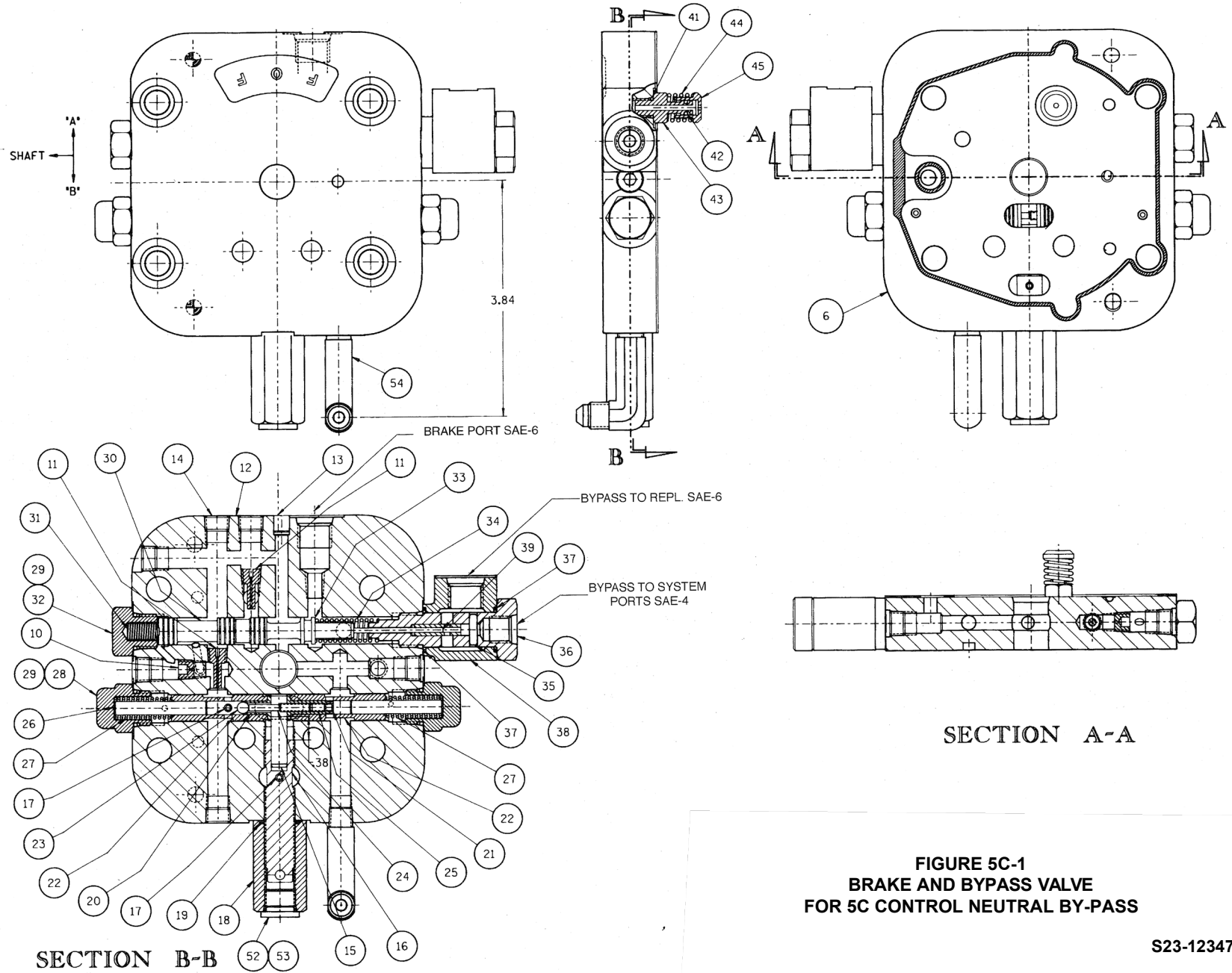

**CODE 60 - HYDRAULIC STROKER**

*S13-48944 Feature 00 (75 - 350 PSI)  
S23-00402 Feature 01 (75 - 435 PSI)  
S23-04305 Feature 02 (100 - 380PSI)*

**DESCRIPTION**

This cross-center control actuates the rotary input shaft by means of a hydraulic piston. The piston is trapped between two caged springs, which are set to provide zero displacement. Pilot pressure applied to either end of the piston causes it to move either side of center in proportion to the pilot pressure, thus positioning the rotary servo in proportion to pilot pressure.

**DISASSEMBLY**

See Figure 60

1. Remove screws (10). Remove control from pump. Examine servo plate for excessive scratching. Note if orifices in stem are open. If servo plate is scratched or orifices appear to be plugged, remove plate and servo stem by removing two socket setscrews from plate, then alternately loosening the two button head screws under the set screws.
2. Remove screws (24) and remove cover (23). Loosen screw (4).
3. Remove servo shaft assembly and clamp (8).
4. Remove screws (26) and remove the centering adjusting group intact. Note: signal pressure setting is determined by the spring preload. Do not disassemble or change unless parts are damaged or setting is incorrect.
5. Remove spool (13). Do not remove stroker body from valve cover unless damaged, or seals need replaced.

See Figure 60-1

6. Examine shoes (1-5) and (1-7) for contamination in balance pads or excessive scratching on faces. Note: the two shoes are not identical and must be installed in the proper position on reassembly.

**ASSEMBLY**

All parts are to be inspected and be free of material defects, dirt, scratches or any foreign material.

All parts are to be cleaned with a suitable cleaning solvent and all cores and passages blown out with clean dry compressed air.

After cleaning and inspection, all parts are to be covered with a light film of oil and should be protected from dirt and excessive handling until assembled onto the unit.

During assembly, lapped and ground surfaces should be kept lubricated and protected from nicks or surface damage.

**REWORK OF WEAR PARTS**

Description	Rework
Servo plate face	Fine stone to remove raised burrs & dings
Shear seal	Fine stone to remove raised burrs & dings. Note: grooves to supply balance pads must be present and adequate.
Control cover	Stone or lap inside face to remove raised burrs & dings.
Spool	Break sharp edges or dings.
Shoe	Stone to remove raised burrs or dings.

See Figure 60

1. If stroker housing was removed from control cover, install O-ring (25A) in housing and O-rings (5) and (7) on interface between parts. Slip servo shaft through the bore, and install screws (6). Torque to 25 lbs-ft. (33.9 Nm). Check for free motion of shaft. Remove shaft.

See Figure 60-1

2. Apply pipe sealant to the 1/8" pipe plug (12) and install in the cover plate. Torque to 100 lbs-in.. (11.3 Nm)
3. Install O-ring (1-8) in groove of shear seal (1-5). Install shear seal with O-ring in the large hole on the servo link, on the servo shaft side. Be certain that the shear seal is sitting with the flange flush against the servo link surface.
4. Install thrust washers (1-9) over servo shaft and seat against the servo link.
5. Place two spring washers (1-6), nested with the bent sections matching each other, into the large hole in the servo link (1-3).
6. Place washer (1-10) against the spring washers.

Note: The shear seal will fit in one position only. Otherwise one side will be held up by the lip of the servo link. Shear seal (1-5) must be installed to face against the cover plate. This shear seal differs from shear seal (1-7) in that the face surface is machined with two .094" (2.4 mm) radius scallops.

7. Install O-ring (1-8) into groove in the remaining shear seal (1-7). Note: This shear seal does not contain the two .094 radius scallops in the face. Place on top of washer, (1-10). Position shear seal to match the lip on the servo link (1-3).

See Figure 60

8. Install spool (13) in stroker body. Press dowel (9) into clamp (8) to .500" (12.7mm) dimension shown. Install screw (4) in clamp. Slip clamp into body to engage groove in spool (13). Slip servo shaft assembly through the body and through the clamp.

9. Tighten the clamp only enough to hold the clamp snugly against the bushing, while permitting the shaft to turn in the clamp with light force.

10. Holding a flat plate against the ends of the spool bore, rotate the shaft clockwise and counterclockwise, causing spool (13) to travel from flush one side to flush the other side. Observe the position of the shear seal relative to the two 3/16 dowel holes in the cover. Position such that the overlap is equal on each side. Eliminate end play and torque screw (4) to 72 lbs-in. (8 Nm), locking the clamp to the shaft

11. Place washers (17) into end connection (2) Place spring (16) on washer. Insert screw (21) into spring guide (14) and thread into end connection. Thread screw until spring guide (14) extends .308" (7.82 mm). beyond mating surface of end conn. (2). Thread nut (18) hand tight.

12. Place washer (15) and O-ring (22) in position as shown.

13. Using screws (26) bolt end connection (2) onto body (25). Torque to 14 lbs-ft. (19 Nm).

14. Install O-ring (19) on plug (20) and insert into end connection.

15. Repeat steps 11 thru 14 on other end.

16. Install cover (23) with cover screws (24) and O-ring (27). Torque screws to 14 lbs-ft. (19 Nm).

17. If control is to be tested on pump, install on pump control pad with gasket (7), ref Fig. 60-1, Nyltite washers (12), and screws (10). Torque to 30 lb. ft. (40.8 Nm).

**TEST**

Connect servo source, adjustable to 450 psi (31 bar), to control ports on hydraulic stroker through a 4-way valve. Center position must dump both ports to tank at min. pressure.

1. To set pump centering, remove plugs from ends of centering groups. Alternately adjust screws by backing out on one slightly and turning in on the opposite screw the same amount, (till it just contacts the spool), observing pump flow and pressure till minimum flow and pressure are obtained and there is no backlash. Stroke pump to full and release, on both sides of center. Pump shall return to zero stroke within 200 psi (13.8 bar) max.

2. Apply servo pressure to one port of stroker. Adjust pressure from minimum to maximum. Note the pressure at which pump just starts to stroke, and the pressure at which the pump reaches full stroke These pressures must be within the following values:

**PUMP CONTROL PRESSURE**

If pressures are incorrect, control may be disassembled and washers added or deleted in the spring box on the opposite end. Each washer (17) added (or removed) increases (or decreases) control pressure approximately 10 psi for 00 and 02 control features, and 12 psi for the 01 control feature.

3. With minimum signal, pump shall return to zero stroke within 200 psi (13.8 bar) max.

<b>Control Feature</b>	<b>Pressure Start</b>	<b>Pressure Full</b>
00	75± 15 psi (5.2± 1 bar)	335± 25 psi (23.1±1.7 bar)
01	75± 15 psi (5.2± 1 bar)	435± 25 psi (30± 1.7 bar)
02	100± 15 psi (6.9± 1 bar)	375± 25 psi (25.9± 1.7 bar)

4. Repeat test on opposite side of center.

5. Increase and decrease control pressure between 0 and 450 psi (31 bar) several times . Pump stroke should follow control pressure smoothly and proportionally. Full to zero or zero to full stroke should be achieved in no more than two seconds. Adjust control pressure up to 50% stroke from zero stroke, then adjust down from full stroke to the same value. The control pressure at the two settings shall not vary more than 50 psi (3.4 bar) from each other.

**PARTS LIST**

*For Figure 60 Hydraulic stroker*

ITEM	DESCRIPTION	Feature → PART NO.	00 QTY.	01 QTY.	02 QTY.
1	Rotary servo (Fig. 6O-1)	S13-47528	1	1	1
2	End connection	033-53590	2	-	2
	End connection	033-53783	-	2	-
4	Screw, SHC, 10-24 x 1/2	358-10080	1	1	1
5	O-ring, 70 S-1 ARP 017	671-00017	1	1	1
6	Screw, SHC, 5/16-18 x 1-1/4	358-14180	2	2	2
7	O-ring, 70 S-1 ARP 012	671-00012	2	2	2
8	Clamp	033-72111	1	1	1
9	Pin	033-53894	1	1	1
10	Screw, HWHD 3/8-16 x 1 1/4	353-25018	4	4	4
12	Washer, Nyltite #37	631-45007	4	4	4
13	Spool	033-53439	1	1	1
14	Spring guide	033-53420	2	-	2
	Spring guide	033-57489	-	2	-
15	Thrust washer	031-53421	2	2	2
16	Spring	033-53627	2	-	2
	Spring	033-53782	-	2	-
17	Washer	035-53452	2	2	8
18	Nut	333-12614	2	2	2
19	O-ring, 90 S-1 ARP 908	691-00908	2	2	2
20	Plug, 8-P5N-S	488-35002	2	2	2
21	Screw	033-53419	2	2	2
22	O-ring, 70 S-1 ARP 022	671-00022	2	2	2
23	Cover	031-53148	1	1	1
24	Screw, SHC 1/4-20 x 5/8	358-12100	4	4	4
25	Body sub assy.	S13-48902	1	1	1
25A	O-ring, 70 S-5 ARP 110	675-00110	1	1	1
26	Screw, SHC 1/4-20 x 3/4	358-12120	8	8	8
27	O-ring, 70 S-1 ARP 133	671-00133	1	1	1
28	Tag	036-24496	-	1	1
29	Screw, RDHD drive #2 x 3/16 SS	320-10203	-	2	2

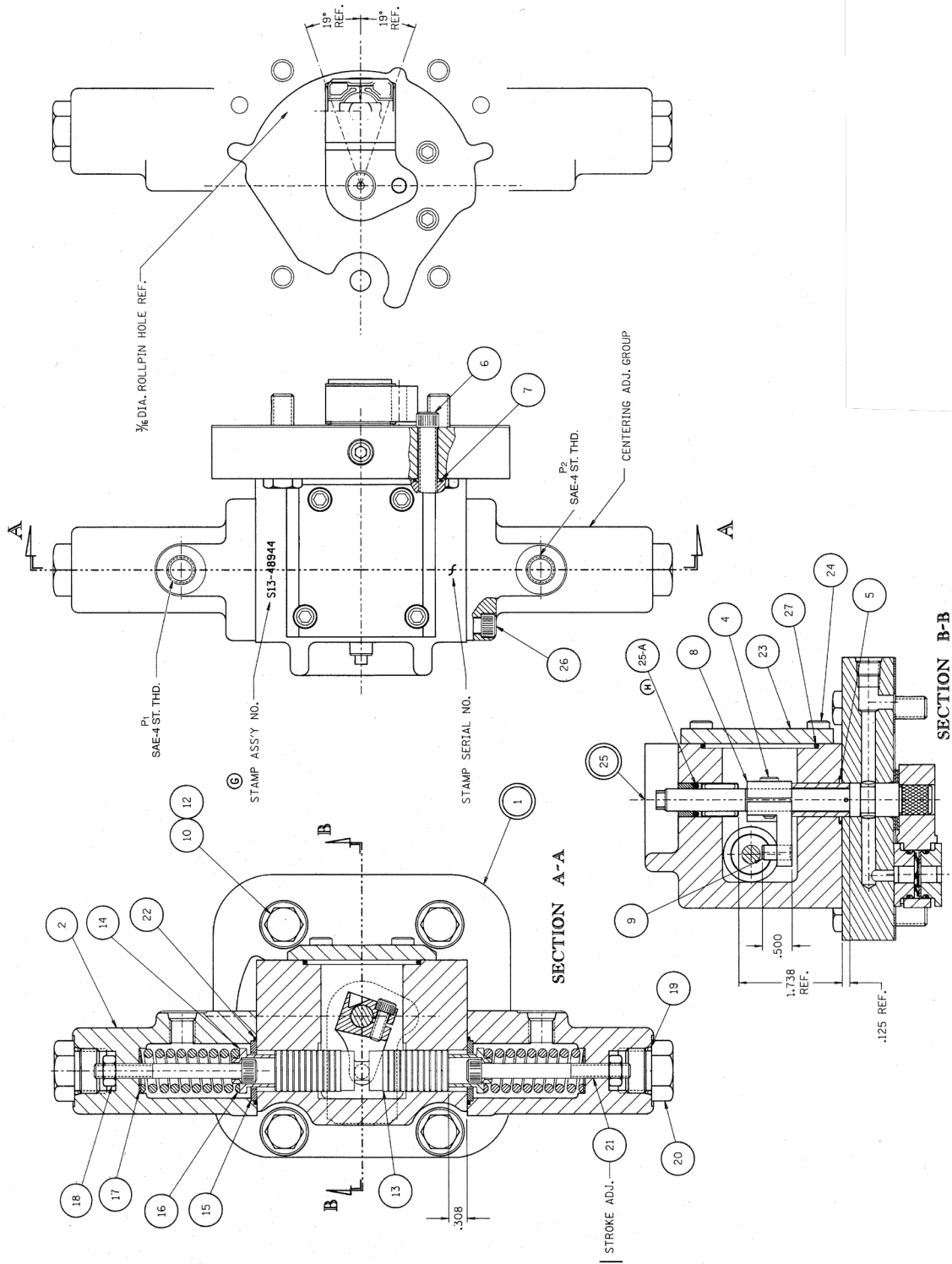

FIGURE 60  
HYDRAULIC STROKER

**PARTS LIST**

For Figure 60-1 - Servo for hydraulic stroker

S13-47528

ITEM	DESCRIPTION	PART NO.	QTY.
1	Servo shaft assembly	S23-00620	(1)
1-1	Servo shaft	033-54841	1
1-3	Servo link	033-70536	1
1-5	Shear seal, feed	033-71371	1
1-6	Washer, finger spring	350-10067	2
1-7	Shear seal	033-70525	1
1-8	O-ring, 70 S-5 ARP 017	675-00017	2
1-9	Thrust washer	350-10103	3
1-10	Thrust washer	350-10064	1
7	Gasket	033-91058	1
9	Cover plate	033-72535	1
12	Plug, 1/8 NPTF flush	431-90204	1

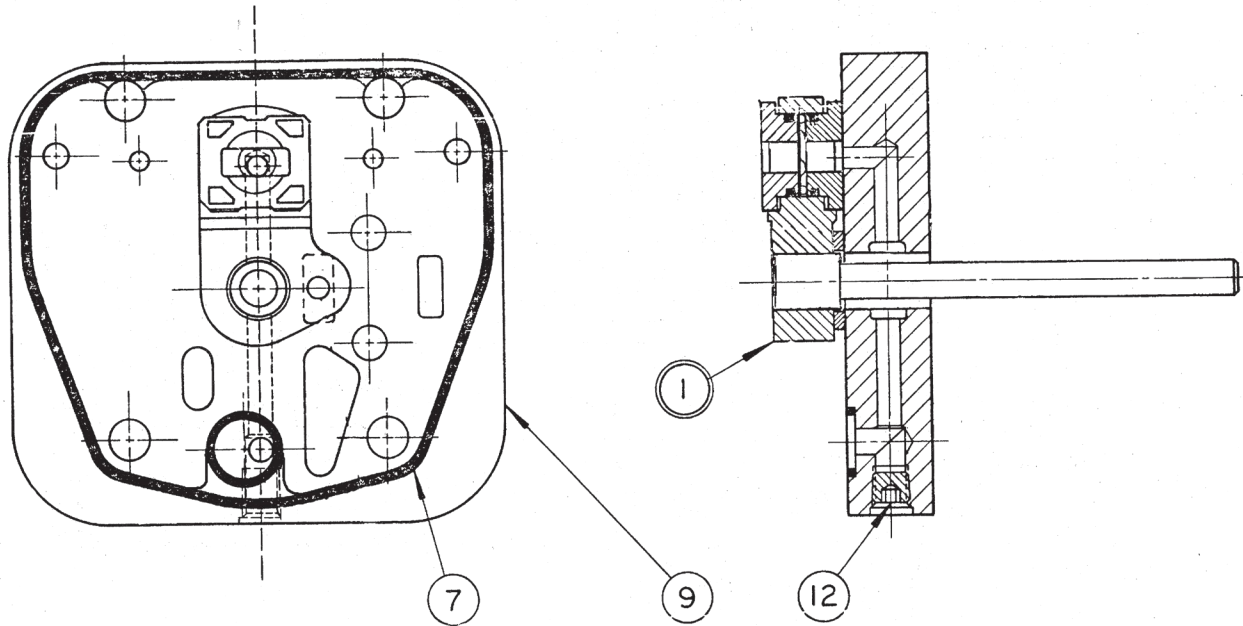

**FIGURE 60-1**  
**SERVO FOR HYDRAULIC STROKER**

**CODE 6A - HYDRAULIC STROKER/ADJUSTABLE STOPS PUMP**

S23-12289  
 Feature 00, CW -A Mtg, CCW - B Mtg.

S23-12290  
 Feature 00, CW -B Mtg, CCW - A Mtg.

S23-12291  
 Feature 01, CW -A Mtg, CCW -B Mtg.

S23-12292  
 Feature 01, CW -B Mtg, CCW -A Mtg.

**MOTOR**

S23-12304 Feature 0\*, B Mtg  
 S23-12305 Feature 1\*, A Mtg  
 S23-12293 Feature 1\*, B Mtg.  
 S23-12306 Feature 2\*, A Mtg.  
 S23-12295 Feature 3\*, A Mtg.

**DESCRIPTION**

This one side of center control is used on both pumps and motors. It contains a spring biased spool in the control cover that is operated by the signal port. This positions the rotary servo proportionally to pilot or control pressure. With no external control pressure and the centering spring properly adjusted, the stroking piston will position the rotary servo at the zero stroke position for pumps, and for motors at the full stroke position. With full signal, the stroking piston will position the rotary servo at full position for pumps, and for motors at 1/3 stroke position. Minimum and maximum stops are fully adjustable.

**DISASSEMBLY**

See Figure 6A

1. Remove screws (10). Remove control from unit. Examine servo plate for excessive scratching. Note if orifices in stem are open. If servo plate is scratched or orifices appear to be plugged, remove plate and servo stem by removing two socket set screws from plate, then alternately loosening the two button head screws under the set screws.
2. Remove screws (24) and remove the centering adjusting group intact. Do not disassemble or change unless parts are damaged or setting is incorrect.
3. Remove screws (29) and cover (28) with assembled parts.
4. Remove screws (22) and remove cover (21). Loosen screw (4).
5. Remove servo shaft assembly. Remove clamp (8).
6. Examine shoes on servo shaft assembly for contamination in balance pads or excessive scratching on faces. Note: the two shoes are not identical and must be installed in the proper position on reassembly.
7. Remove spool (12). Do not remove stroker body from valve cover unless seals need replaced.

**ASSEMBLY**

See Figure 6A-1

After cleaning and inspection, all parts are to be covered with a light film of oil and should be protected from dirt and excessive handling until assembled onto the unit. During assembly, lapped and ground surfaces should be kept lubricated and protected from nicks or surface damage.

**REWORK OF WEAR PARTS**

Part Description	Rework
Servo plate face	Fine stone to remove raised burrs & dings
Shear seal	Fine stone to remove raised burrs & dings. Note: grooves to supply balance pads must be present and adequate.
Control cover	Stone or lap inside face to remove raised burrs & dings.
Spool	Break sharp edges or dings.

1. Apply pipe sealant to the 1/8" pipe plug (12) and install in the cover plate (9). Torque to 100 lbs-in. (11.3 Nm).
2. Install O-ring (1-8) in groove of shear seal (1-5). Install shear seal with O-ring in the large hole on the servo link, on the servo shaft side. Be certain that the shear seal is sitting with the flange flush against the servo link surface.

Note: The shear seal will fit in one position only. Otherwise one side will be held up by the lip of the servo link. Shear seal (1-5) must be installed to face against the cover plate. This shear seal differs from shear seal (1-7) in that the face surface is machined with two .094" (2.4 mm) radius scallops.

See Figure 6A

3. Install thrust washers (1-9) over servo shaft and seat against the servo link.
4. Install O-ring (23-A) in housing (23).
5. Install O-rings (5) and (7) on interface between stroker housing (23) and cover (1). Slip servo shaft assembly through the bore, and install screws (6). Torque to 25 lbs-ft. (33.9 Nm). Check for free motion of shaft assembly. Remove shaft.
6. Install spool (12) into stroker body. Press dowel (9) into clamp (8) to .500" (12.7mm) dimension shown. Install screw (4) in clamp. Slip clamp into body to engage groove in spool (12). Slip shaft through the body and through the clamp.
7. Tighten the clamp only enough to hold the clamp snugly against the bushing, while permitting the shaft to turn in the clamp with light force.
8. Install setscrew (30) in cover (28). For pump controls, set to .308" (7.82mm) inside extension. For motor controls, set to 410" (10.4mm) inside extension and install two nuts (31) locked together to maintain this dimension. Install nut (31), O-ring (32), plug (27) and O-ring (26) on external extension.
9. Install O-ring (20) in cover (28) and mount on housing on opposite side from centering assembly, (see chart below) with screws (29). Torque screws to 14 lbs-ft. (19 Nm).
10. For pump controls, hold a flat plate against the centering group end of the spool bore. Position clamp such that the spool is flush with the edge of the bore when the servo shoe is tangent to the corresponding dowel hole in the control face. Eliminate end play and torque screw (4) to 72 in.-lb. (8 Nm), locking the clamp to the shaft. Check for free motion.
- For motor controls, hold spool (12) against the stop screw, (30) and tighten screw (4), locating the servo shoe adjacent to the corresponding dowel hole in the control face. Torque to 72 in.-lb. (8 Nm), locking the clamp to the shaft. Check for free motion.
11. Install spring guide (13) and spring (14) over screw (19). Install screw into adjust-ment screw (18). Adjust to 2" compressed length on spring (14). Install 1/4-20 nut (17).
12. Insert spring assembly in body (2). Adjust for correct extension of spring guide beyond surface. (See below). Install O-ring (20) in locknut, and install acorn nut (16) on screw (18).
13. Install O-ring (20) in body and place assembly on stroker body, according to chart below:

**PUMP**

Spring Guide Extension .308"  
(7.82MM)

Rotation & cont. mtg	Centering group location
CW -- A	See Fig. 6-A
CW - B	Opposite to Fig. 6-A
CCW - A	Opposite to Fig. 6-A
CCW - B	See Fig. 6-A

**MOTOR**

Spring Guide Extension .206"  
(5.23MM)

Control mounting	Centering group location
B	See Fig. 6-A
A	Opposite to Fig. 6-A

14. Using screws (24) bolt end connection (2) onto body (23). Torque screws to 14 lbs-ft. (19 Nm).
15. Install O-ring (25), cover (21), and cover screws (22). Torque screws to 14 lbs-ft. (19 Nm).
16. Place two spring washers (1-6), nested with the bent sections matching each other, into the large hole in the servo link.
17. Place washer (1-10) against the spring washers.
18. Install O-ring (1-8) into groove in the remaining shear seal (1-7). Note: This shear seal does not contain the two .094" radius scallops in the face. Place on top of washer, (1-10). Position shear seal to match the lip on the servo link.
19. If control is to be tested on unit, install on control pad with gasket, nyltite washers (12), and screws (10). Torque to 30 lb. ft. (40.8 Nm).

Connect servo source, adjustable to 450 psi (31 bar), to control port on hydraulic stroker.

**TEST**

1. Set pump (motor) to zero (full) stroke by adjusting minimum (maximum) stop screw (30).
2. Apply servo pressure to signal port of stroker. Adjust pressure from minimum to maximum. Note the pressure at which unit just starts to stroke, and the pressure at which the unit reaches the final stroke These pressures must be within the following values:

**PUMP CONTROL PRESSURE**

<b>CONTROL FEATURE</b>	<b>PRESSURE START</b>	<b>PRESSURE FULL</b>
00	75± 15 psi (5.2± 1 bar)	335± 25 psi (23.1±1.7 bar)
01	75± 15 psi (5.2± 1 bar)	435± 25 psi (30± 1.7 bar)
02	100± 15 psi (6.9± 1 bar)	375± 25 psi (25.9± 1.7 bar)
03	150±15 psi (10.3±1 bar)	400± 25 psi (27.6± 1.7 bar)

**MOTOR CONTROL PRESSURE**

<b>CONTROL FEATURE</b>	<b>PRESSURE FULL</b>	<b>PRESSURE 1/3 STROKE</b>
0*	170± 15 psi (11.7± 1 bar)	335± 25 psi (23.1±1.7 bar)
1*	200± 15 psi (13.8± 1 bar)	435± 25 psi (30± 1.7 bar)
2*	150± 15 psi (10.3± 1 bar)	375± 25 psi (25.9± 1.7 bar)
3*	75±15 psi (5.17±1 bar)	250± 25 psi (17.2± 1.7 bar)

If pressures are incorrect, use adjusting screw (18) to obtain correct pressure.

3. With minimum signal, unit shall return to starting stroke, pumps to zero, and motors to full displacement.
4. With full control signal pressure on control port, set screw (19) for final stroke, Pumps at full, and motors at 1/3 stroke. Lock adjustments and install acorn nut (16).
5. Increase and decrease control pressure between 0 and 450 psi (31 bar) several times . Stroke should follow control pressure smoothly and proportionally. Full to minimum or minimum to full stroke should be achieved in no more than two seconds. Adjust control pressure up to 50% stroke from initial stroke, then adjust down from final stroke to the same value. The control pressure at the two settings shall not vary more than 50 psi (3.4 bar) from each other.

**PARTS LIST**

For figure 6A hydraulic stroker/adjustable stops

**PUMP CONTROLS**

S23-12289

Feature 00, CW - A, CCW - B Mtg.

S23-12290

Feature 00, CW - B, CCW - A Mtg.

S23-12291

Feature 01, CW - B, CCW - A Mtg.

S23-12292

Feature 01, CW - B, CCW - A Mtg.

**MOTOR CONTROLS**

S23-12304 Feature 0\*, B Mtg.

S23-12305 Feature 1\*, A Mtg.

S23-12293 Feature 1\*, B Mtg.

S23-12306 Feature 2\*, A Mtg.

S23-12295 Feature 3\*, A Mtg.

Feature →			00,02,03	01	1*, 2*	0*, 3*
			Pump	Pump	Motor	Motor
ITEM	DESCRIPTION	PART NO.	QTY.	QTY.	QTY.	QTY.
1	Rotary servo (Fig. 6O-1)	S13-47528	1	1	1	1
2	End connection	033-53880	1	1	1	1
4	Screw, SHC, 10-24 x 1/2	358-10080	1	1	1	1
5	O-ring 70 S-1 ARP 017	671-00017	1	1	1	1
6	Screw, SHC 5/16-18 x 1 1/4	358-14180	2	2	2	2
7	O-ring, 70 S-1 ARP 012	671-00012	2	2	2	2
8	Clamp	033-72111	1	1	1	1
9	Pin	033-53894	1	1	1	1
10	Screw, HWHD 3/8-16 x 1 1/4	353-25018	4	4	4	4
11	Washer, Nyltite #37	631-45007	4	4	4	4
12	Spool	033-53439	1	1	1	1
13	Spring guide	033-53420	1	1	1	1
14	Spring	033-54269	1			1
	Spring	033-57486		1	1	
15	Locknut	033-53877	1	1	1	1
16	Acorn nut, 7/8-14	327-25007	1	1	1	1
17	Hex nut	333-12614	1	1	3	3
18	Adjustment screw	033-53876	1	1	1	1
19	Slotted screw	033-53878	1	1	1	1
20	O-ring, 70 S-1 ARP 022	671-00022	4	4	4	4
21	Cover	031-53148	1	1	1	1
22	Screw, SHC 1/4-20 x 5/8	358-12100	4	4	4	4
23	Body-sub assembly	S13-48902	1	1	1	1
23-A	O-ring, 70 S-5 ARP 110	675-00110	1	1	1	1
24	Screw, SHC 1/4-20 x 1	358-12160	4	4	4	4
25	O-ring, 70 S-1 ARP 133	671-00133	1	1	1	1
26	O-ring, 90 S-1 ARP 902	691-00902	1	1	1	1
27	Plug, 2HP5N-S	488-35046	1	1	1	1
28	Cover	033-53879	1	1	1	1
29	Screw, SHC 1/4-20 x 1 1/2	358-12200	4	4	4	4
30	Setscrew, 1/4-20 x 1 3/4	311-12220	1	1	1	1
31	Cover nut 1/4-20	033-91039	1	1	1	1
32	O-ring, 70 S-1 ARP 011	671-00011	1	1	1	1
33	Thrust washer	031-53421	1	1	1	1

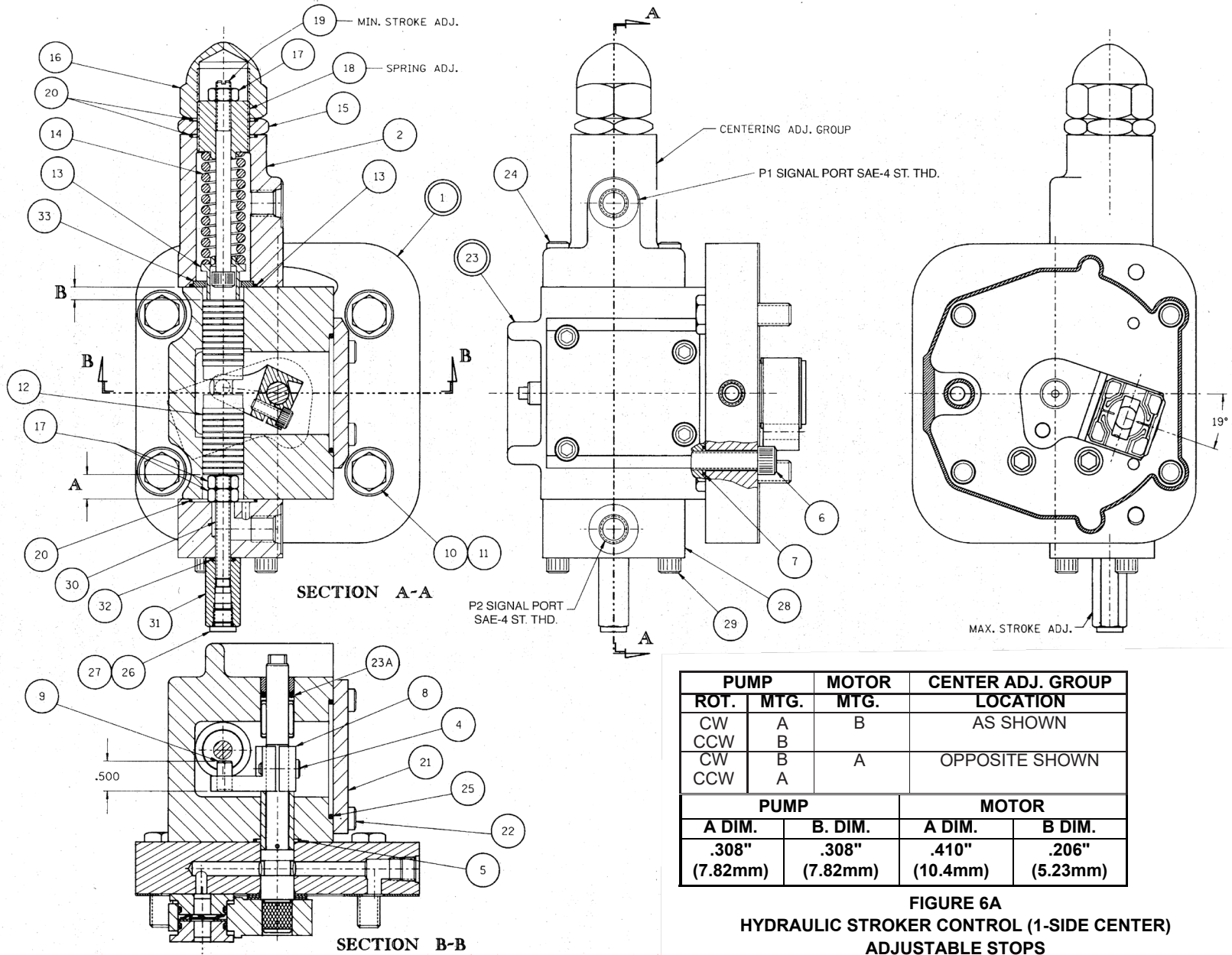

FIGURE 6A  
HYDRAULIC STROKER CONTROL (1-SIDE CENTER)  
ADJUSTABLE STOPS

**CODE 6B - HYDRAULIC  
STROKER WITH BRAKE AND  
BYPASS**

*S23-12424 Feature 00 (75 - 350 PSI)*

*S23-12423 Feature 01 (75 - 435 PSI)*

*S23-12422 Feature 02 (100 - 380 PSI)*

*23-12544 Feature 03 (150 - 400 PSI)*

**DESCRIPTION**

This cross-center control actuates the rotary input shaft by means of a hydraulic piston. The piston is trapped between two caged springs, which are set to provide zero displacement. Pilot pressure applied to either end of the piston causes it to move either side of center in proportion to the pilot pressure, thus positioning the rotary servo in proportion to pilot pressure.

In the rotary servo body is contained the brake and bypass valve option. A brake spool, when energized, connects the brake port to servo pressure. When de-energized, a spring shifts the spool, connecting the brake port to tank. Another port, located on the end of the brake valve, is closed by the energizing of the brake spool. When de-energized, this port dumps both pump system ports to the replenishing source, thus bypassing the small flow generated by slight errors on zero position.

The operation is controlled in this manner: A restricted servo flow is applied to shift the brake spool. This flow is dumped when a slot in the servo plate aligns with a passage connecting to this spool. This occurs when the pump is on zero stroke. Another restricted flow is applied to a spool adjacent to the brake spool. This metered signal is connected to a port controlled by the input command spool. This port is set to open to tank when the input command is at zero stroke.

The brake spool is thus de-energized to set the brake when BOTH the pump cam is at zero stroke and the rotary servo is at zero command. If the pump is on stroke or the input is on stroke, the brake spool is energized, releasing the brake.

**DISASSEMBLY**

*See Figure 6B*

1. Disconnect brake and bypass lines from control. Remove screws (10). Remove control from pump. Examine servo plate for excessive scratching. Note if orifices in stem are open. If servo plate is scratched or orifices appear to be plugged, remove plate and servo stem by removing two socket setscrews from plate, then alternately loosening the two button head screws under the set screws.
2. Remove screws (24) and remove cover (23). loosen screw (4).
3. Remove servo shaft assembly (25) and clamp (8).
4. Examine shoes (25-5) and (25-7) for contamination in balance pads or excessive scratching on faces. Note: the two shoes are not identical and must be installed in the proper position on reassembly.
5. Remove screws (26) and remove the centering adjusting group intact. Note: signal pressure setting is determined by the spring preload. Do not disassemble or change unless parts are damaged or setting is incorrect.
6. Remove spool (13). Do not remove stroker body from valve cover unless damaged, or seals need replaced.

*See Figure 6B-1*

7. Remove plug (30). Remove plug (28) with attached parts. Remove spool (25).
8. Remove bypass valve body (39) with fitting (41) and piston (42). Remove plug (35) and spring (34). Remove spools (33) and (36).
9. Remove shoe (48), and spring (47).
10. Examine two orifices (11) and orifice (10) in body for contamination. Examine passages in body for free flow.
11. Clean and examine all parts for breakage or evidence of abnormal wear.

**ASSEMBLY**

All parts are to be inspected and be free of material defects, dirt, scratches or any foreign material.

All parts are to be cleaned with a suitable cleaning solvent and all cores and passages blown out with clean dry compressed air.

After cleaning and inspection, all parts are to be covered with a light film of oil and should be protected from dirt and excessive handling until assembled onto the unit. During assembly, lapped and ground surfaces should be kept lubricated and protected from nicks or surface damage.

**REWORK OF WEAR PARTS**

Part Description	Rework
Servo plate face	Fine stone to remove raised burrs & dings
Shear seal	Fine stone to remove raised burrs & dings. Note: grooves to supply balance pads must be present and adequate.
Control cover	Stone or lap inside face to remove raised burrs & dings.
Spool	Break sharp edges or dings.
Shoe	Stone to remove raised burrs or dings.

See Figure 6B-1

1. Install Lee Pluget (13) using installation tool and gage.
2. Install orifices (10) and (11) in body. Make sure that the orifice (11) in the deeper bore extends past the wall of the valve bore and will not interfere with spools (25) or (33) action.
3. Install 1/16 pipe plug (27) into cover (12). Plug must extend below bore, so it will not interfere with spool (25).
4. Apply pipe sealant to the 1/8" pipe plugs (14) and install in the cover plate. Torque to 100 in.-lbs. (11.3 Nm)
5. If stroker housing was removed from control cover, install O-ring (12-1A) in housing and O-rings (12-3) and (12-5) on interface between parts. Slip servo shaft through the bore, and install screws (12-4). Torque to 25 lbs-ft. (33.9 Nm). Check for free motion of shaft. Remove shaft. Slip spools (25), (33) and (36) into their respective bores and check for free travel. If tight, it may be necessary to carefully hone the bore, till spools are free in bores. Position spool (25) in the bore with the slot, with the elongated hole centered over the slot and the grooved end toward the orifice (33).
6. Install O-ring (29) on nut (28) and the neutral bypass trimmer assembly into nut (28). Install nut (28) into cover. Adjust trimmer assembly until the land on end of assembly is centered in groove in spool (25), with elongated hole in spool centered on slot in cover. Hold in place and install nut (31), O-ring (32), plug (6) and O-ring (44).
7. Install O-ring (29) on plug (30) and install on other end of this bore.
8. Install spools (33) and (36) into the other cross-bore in the cover (12). The slotted end of spool (33) should be to the outside.
9. Install O-ring (29) on plug (35). Install spring (34) in plug and install plug in cover as shown.
10. Install O-rings (40) on fitting (41). Install piston (42) in bore of body (39). Install fitting (41) on body and install assembly in cover (12).
11. Install O-rings (44) and (45) on vent post (46). Install vent post in cover.
12. Install spring (47) and shoe (48) over vent post.
13. Install O-ring (19) on plug (18) and install in body (12).

See Figure 6B

14. Install O-ring (25-8) in groove of shear seal (25-5). Install shear seal with O-ring in the large hole on the servo link, on the servo shaft side. Be certain that the shear seal is sitting with the flange flush against the servo link surface.
15. Install needle bearing (25-9) over servo shaft and seat against the servo link. Install thrust washer (25-4) over needle bearing.

Note: The shear seal will fit in one position only. Otherwise one side will be held up by the lip of the servo link. Shear seal (25-5) must be installed to face against the cover plate. This shear seal differs from shear seal (25-7) in that the face surface is machined with two .094" (2.4 mm) radius scallops.

16. Install spool (13) in stroker body. Press dowel (9) into clamp (8) to .500" (12.7mm) dimension shown. Install screw (4) in clamp. Slip clamp into body to engage groove in spool (13). Slip servo shaft assembly (25) through the body and through the clamp, simultaneously engaging the pin on the servo arm with the slot in the spool, (25) ref. Fig. 6B-1.
17. Tighten the clamp only enough to hold the clamp snugly against the bushing, while permitting the shaft to turn in the clamp with light force.
18. Holding a flat plate against the ends of the spool bore, rotate the shaft clockwise and counterclockwise, causing spool (13) to travel from flush one side to flush the other side. Observe the position of the shear seal relative to the two 3/16 dowel holes in the cover. Position such that the overlap is equal on each side. Eliminate end play and torque screw (4) to 72 lbs-in. (8 Nm), locking the clamp to the shaft
19. Place washer or washers (17) as required into end connection (2) Place spring (16) on washer. Insert screw (21) into spring guide (14) and thread into end connection. Thread screw until spring guide (14) extends .308" (7.82 mm) beyond mating surface of end conn. (2). Thread nut (18) hand tight.
20. Place washer (15) and O-ring (22) in position as shown.
21. Using screws (26) bolt end connection (2) onto body (25). Torque to 14 lbs-ft. (19 Nm).
22. Install O-ring (19) on plug (20) and insert into end connection.

23. Repeat steps 19 thru 22 on other end.
24. Install cover (23) with cover screws (24) and O-ring (27). Torque screws to 14 lbs-ft. (19 Nm).
25. Place two spring washers (25-6), nested with the bent sections matching each other, into the large hole in the servo link (25-3).
26. Place washer (25-10) against the spring washers.
27. Install O-ring (25-8) into groove in the remaining shear seal (25-7). Note: This shear seal does not contain the two .094 radius scallops in the face. Place on top of washer, (25-10). Position shear seal to match the lip on the servo link.
28. If control is to be tested on pump, install on pump control pad with gasket (51), ref Fig. 6B-1, Nyltite washers (12), and screws (10). Torque to 30 lb. ft. (40.8 Nm). Install bypass check valves, fittings, and lines.

**TEST**

Connect servo source, adjustable to 450 psi (31 bar), to control ports on hydraulic stroker through a 4-way valve. Center position must dump both ports to tank at min. pressure.

Install a needle valve on the bypass valve exhaust port, connected to tank. Close the valve.

1. To set pump centering, remove plugs from ends of centering groups. Alternately adjust screws by backing out on one slightly and turning in on the opposite screw the same amount, (till it just contacts the spool), observing pump flow and pressure till minimum flow and pressure are obtained and there is no backlash. Stroke pump to full and release, on both sides of center. Pump shall return to zero stroke within 200 psi (13.8 bar) max.
2. Apply servo pressure to one port of stroker. Adjust pressure from minimum to maximum. Note the pressure at which pump just starts to stroke, and the pressure at which the pump reaches full stroke These pressures must be within the following values:

**PUMP CONTROL PRESSURE**

<b>CONTROL FEATURE</b>	<b>PRESSURE START</b>	<b>PRESSURE FULL</b>
00	75± 15 psi (5.2± 1 bar)	335± 25 psi (23.1±1.7 bar)
01	75± 15 psi (5.2± 1 bar)	435± 25 psi (30± 1.7 bar)
02	100± 15 psi (6.9± 1 bar)	375± 25 psi (25.9± 1.7 bar)
03	150±15 psi (10.3±1 bar)	400± 25 psi (27.6± 1.7 bar)

If pressures are incorrect, control may be disassembled and washers added or deleted in the spring box on the opposite end. Each washer (17) added (or removed) increases (or decreases) control pressure approximately 10 psi for 00, 02 and 03 control features, and 12 psi for the 01 control feature.

3. With minimum signal, pump shall return to zero stroke within 200 psi (13.8 bar) max.
4. Repeat test on opposite side of center.
5. Increase and decrease control pressure between 0 and 450 psi (31 bar) several times . Pump stroke should follow control pressure smoothly and proportionally. Full to zero or zero to full stroke should be achieved in no more than two seconds. Adjust control pressure up to 50% stroke from zero stroke, then adjust down from full stroke to the same value. The control pressure at the two settings shall not vary more than 50 psi (3.4 bar) from each other.
6. With pump on zero stroke, turn brake trimmer screw CW and CCW while observing gage on brake port. Note the positions where the gage reading changes from case pressure to servo pressure to case pressure. Set and lock the adjustment midway between these two positions.
7. Load the pump. Stroke pump CW. The gage on the brake port should start to indicate servo pressure when the system pressure is between 2000 and 4500 psi (138 and 310 bar), with an increasing signal, and must return to case pressure before system pressure drops to 2000 psi (138 bar), on decreasing signal. Repeat by rotating input shaft CCW. Record both pressures for each rotation of the servo input shaft.
8. Open the needle valve on the neutral bypass port. Measure and record leakage from this port with the pump on center at minimum psi, and with the pump off center, at 5000 psi.

**Maximum leakage with control on center:**

2.0 gpm (7.6 l/m)

**Minimum leakage with control on center:**

1.0 gpm (3.8 l/m)

**Maximum leakage with control off center:**

35 cu. in/min or .15 gpm (574 cm<sup>3</sup>/min. or 0.57 l/m)

9. Unload the pump. Stroke pump above and below center. Control should operate smoothly. Brake pressure should drop to case pressure each time control is on center, and it should indicate servo pressure as soon as input shaft is rotated CW or CCW from center, per step 7.

10. Release control when pump is off center. Pump should return to center. Repeat several times in each direction and at different pressures from 200 to 5000 psi (13.8 to 345 bar)

11. Remove needle valve from bypass exhaust port and install exhaust line.

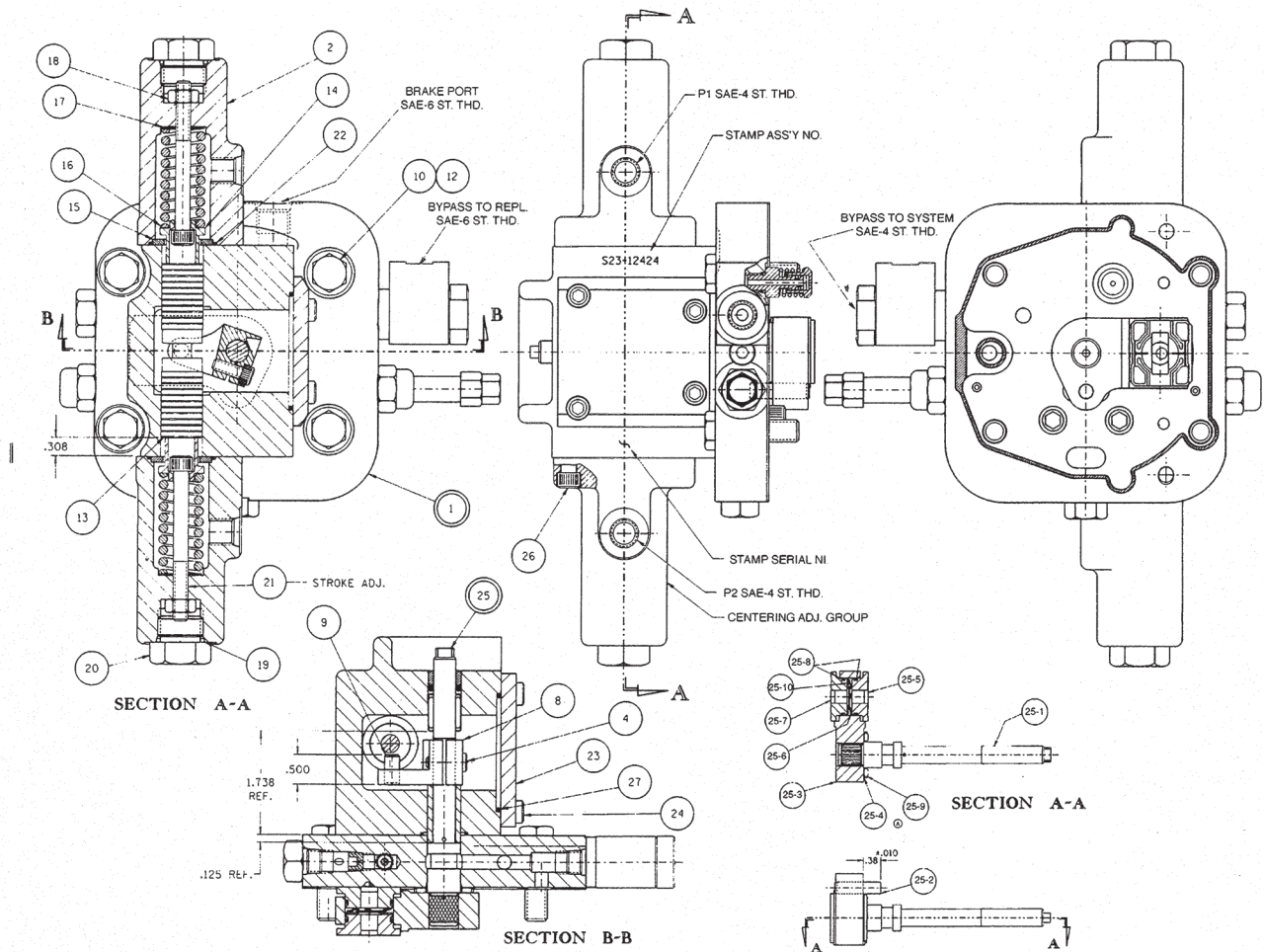

**FIGURE 6B  
HYDRAULIC STROKER  
WITH BRAKE AND BYPASS VALVE**

**PARTS LIST**

For Figure 6B Hydraulic stroker  
with brake and bypass valve

S23-12424      Feature 00

S23-12423      Feature 01

S23-12422      Feature 02

S23-12544      Feature 03

		Feature →	00	01	02	03
ITEM	DESCRIPTION	PART NO.	QTY.	QTY.	QTY.	QTY.
1	Neutral bypass/brake subassy.(Fig. 6B-1)	S23-12335	1	1	1	1
2	End connection	033-53590	2	-	2	2
	End connection	033-53783	-	2	-	-
4	Screw, SHC, 10-24 x 1/2	358-10080	1	1	1	1
8	Clamp	033-72111	1	1	1	1
9	Pin	033-53894	1	1	1	1
10	Screw, HWHD 3/8-16 x 1 1/4	353-25018	4	4	4	4
12	Washer, Nyltite #37	631-45007	4	4	4	4
13	Spool	033-53439	1	1	1	1
14	Spring guide	033-53420	2	2	2	2
15	Thrust washer	031-53421	2	2	2	2
16	Spring	033-53627	2	-	2	-
	Spring	033-53782	-	2	-	-
	Spring	225-92092	-	-	-	2
17	Washer	035-53452	2	2	8	4
18	Nut	333-12614	2	2	2	2
19	O-ring, 90 S-1 ARP 908	691-00908	2	2	2	2
20	Plug, 8-P5N-S	488-35002	2	2	2	2
21	Screw	033-53419	2	2	2	2
22	O-ring, 70 S-1 ARP 022	671-00022	2	2	2	2
23	Cover	031-53148	1	1	1	1
24	Screw, SHC 1/4-20 x 5/8	358-12100	4	4	4	4
25	Servo shaft assembly	S23-12497	(1)	(1)	(1)	(1)
25-1	Shaft	033-54841	1	1	1	1
25-2	Pin	033-71002	1	1	1	1
25-3	Link	033-70536	1	1	1	1
25-4	Washer	350-10141	1	1	1	1
25-5	Shear seal	033-71371	1	1	1	1
25-6	Washer, finger spring	350-10067	2	2	2	2
25-7	Shear seal	033-70525	1	1	1	1
25-8	O-ring 70 S-5 ARP 017	675-00017	2	2	2	2
25-9	Needle bearing	230-82141	1	1	1	1
25-10	Thrust washer	350-10064	1	1	1	1
26	Screw, SHC 1/4-20 x 3/4	358-12120	8	8	8	8
27	O-ring, 70 S-1 ARP 133	671-00133	1	1	1	1

**PARTS LIST**

For Figure 6B-1 - Brake and  
bypass valve for 600 series

S23-12335

ITEM	DESCRIPTION	PART NO.	QTY.
6	Plug 2HP5N-S	488-35046	1
10	Orifice, .028" (.71 mm), 1/16 PT	037-19104	1
11	Orifice plug	033-71437	2
12	Body and cover	P23-12496	(1)
12-1	Body	S13-48902	1
12-1A	O-ring, 70 S-5 ARP 110	675-00110	1
12-2	Cover	033-91157	1
12-3	O-ring, 70 S-1 ARP 012	671-00012	2
12-4	Screw, SHC, 5/16-18 x 1 1/4	358-14180	2
12-5	O-ring, 70 S-1 ARP 017	671-00017	1
13	Lee Pluget	447-00017	1
14	1/8" Hex flush plug	431-90204	7
18	Plug, 5P5N-S	488-35028	1
19	O-ring, 70 S-1 ARP 905	671-00905	1
25	Spool	035-71026	1
26	Neutral bypass trimmer	S13-40908	1
27	Plug, flush 1/16 PT	431-90104	1
28	Plug	033-70841	1
29	O-ring, 90 S-1 ARP 906	691-00906	3
30	Plug	033-70840	1
30	Soc setscrew, 10-32 x 1"	312-35040	2
31	Cover nut, #10-32	033-91040	1
32	O-ring, 70 S-1 ARP 010	671-00010	1
33	Spool	033-70999	1
34	Spring	033-71112	1
35	Plug, 6P5ON-S	488-35003	1
36	Spool	033-70997	1
37	Spring	033-70992	1
38	Dowel pin, 1/8 x 1/2	324-20808	1
39	Body	033-91090	1
40	O-ring, 90 S-1 ARP 016	691-00016	2
41	Fitting	033-70998	1
42	Piston	033-70993	1
44	O-ring, 90 S-1 ARP 902	691-00902	2
45	O-ring, 70 S-1 ARP 006	671-00006	1
46	Vent post	033-70995	1
47	Compression spring	225-92044	1
48	Shoe	033-70996	1
51	Control gasket	033-91058	1

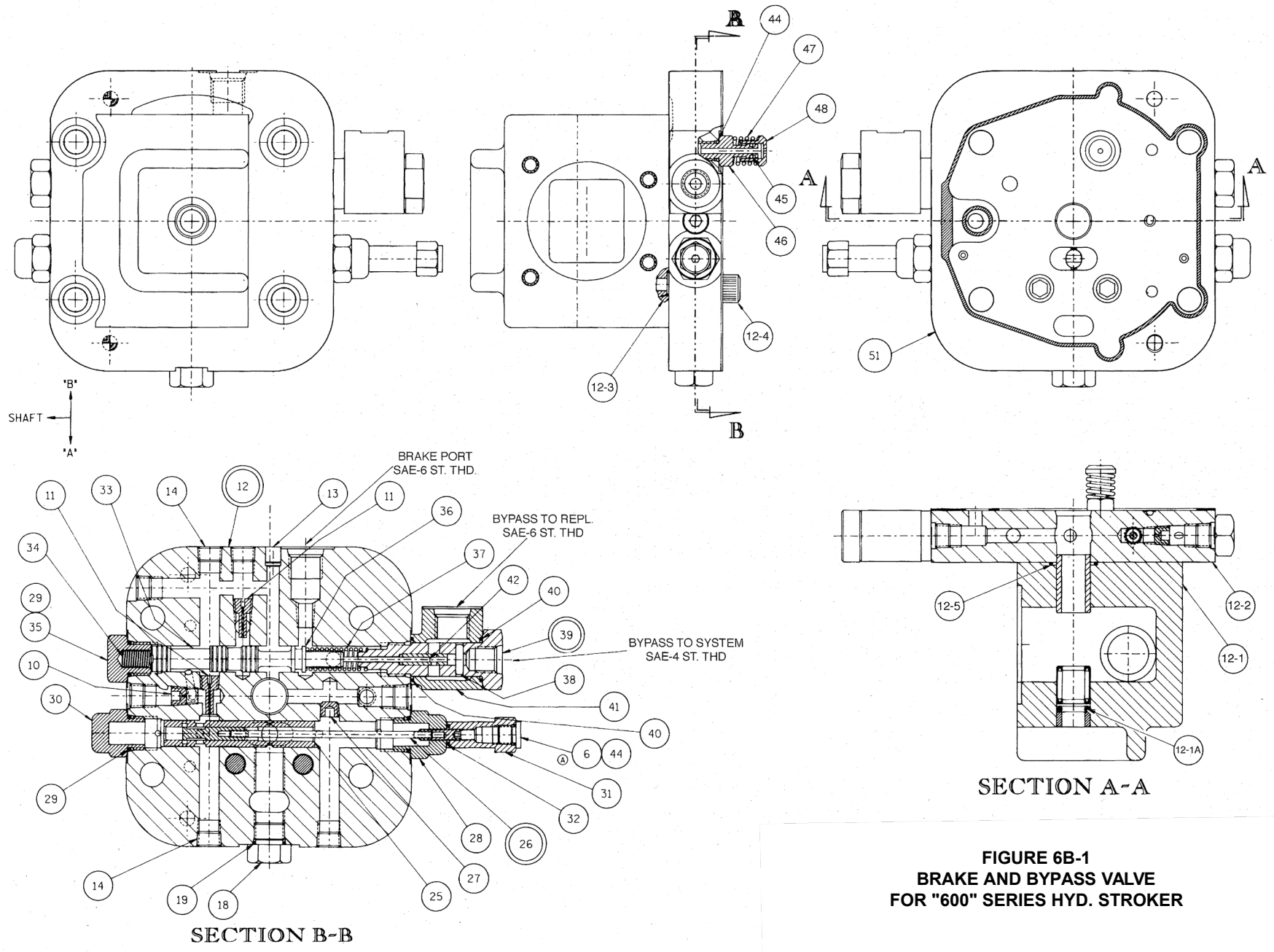

**CODE 6C - HYDRAULIC  
STROKER WITH BRAKE AND  
BYPASS VALVE/ADJ. STOPS**

*S23-12296 Feature 00, CW -A Mtg,  
CCW - B Mtg.*

*S23-12297 Feature 00, CW -B Mtg,  
CCW - A Mtg.*

**DESCRIPTION**

This one side of center control actuates the rotary input shaft by means of a hydraulic piston. The piston is spring loaded to zero stroke. Pilot pressure applied to the end opposite the spring causes the piston to move in proportion to the pilot pressure, thus positioning the rotary servo in proportion to pilot pressure. Maximum and minimum displacements are adjustable from zero to full.

Within the rotary servo body is contained the brake and bypass valve option. A brake spool, when energized, connects the brake port to servo pressure. When de-energized, a spring shifts the spool, connecting the brake port to tank. Another port, located on the end of the brake valve, is closed by the energizing of the brake spool. When de-energized, this port dumps both pump system ports to the replenishing source, thus bypassing the small flow generated by slight errors on zero position.

The operation is controlled in this manner: A restricted servo flow is applied to shift the brake spool. This flow is dumped when a slot in the servo plate aligns with a passage connecting to this spool. This occurs when the pump is on zero stroke. Another restricted flow is applied to a spool adjacent to the brake spool. This metered signal is connected to a port controlled by the input command spool. This port is set to open to tank when the input command is at zero stroke.

The brake spool is thus de-energized to set the brake when BOTH the pump cam is at zero stroke and the rotary servo is at zero command. If the pump is on stroke or the input is on stroke, the brake spool is energized, releasing the brake.

**DISASSEMBLY**

*See Figure 6C*

1. Disconnect brake and bypass lines from control. Remove screws (10). Remove control from pump. Examine servo plate for excessive scratching. Note if orifices in stem are open. If servo plate is scratched or orifices appear to be plugged, remove plate and servo stem by removing two socket set screws from plate, then alternately loosening the two button head screws under the set screws.
2. Remove screws (22) and remove cover (21). Loosen screw (4).
3. Remove servo shaft assembly (23) and clamp (8).
4. Examine shoes (23-5) and (23-7) for contamination in balance pads or excessive scratching on faces. Note: the two shoes are not identical and must be installed in the proper position on reassembly.
5. Remove screws (24) and remove the centering adjusting group intact. Note: signal pressure setting is determined by the spring preload. Do not disassemble or change unless parts are damaged or setting is incorrect.
6. Remove screws (29) and cover (28) with assembled parts.
7. Remove spool (12). Do not remove stroker body from valve cover unless damaged, or seals need replaced.

*See Figure 6B-1*

8. Remove plug (30). Remove plug (28) with attached parts. Remove spool (25).
9. Remove bypass valve body (39) with fitting (41) and piston (42). Remove plug (35) and spring (34). Remove spools (33) and (36).
10. Remove shoe (48), and spring (47).
11. Examine two orifices (11) and orifice (10) in body for contamination. Examine passages in body for free flow.
12. Clean and examine all parts for breakage or evidence of abnormal wear.

**ASSEMBLY**

All parts are to be inspected and be free of material defects, dirt, scratches or any foreign material.

All parts are to be cleaned with a suitable cleaning solvent and all cores and passages blown out with clean dry compressed air.

After cleaning and inspection, all parts are to be covered with a light film of oil and should be protected from dirt and excessive handling until assembled onto the unit. During assembly, lapped and ground surfaces should be kept lubricated and protected from nicks or surface damage.

REWORK OF WEAR PARTS

Description	Rework
Servo plate face	Fine stone to remove raised burrs & dings
Shear seal	Fine stone to remove raised burrs & dings. Note: grooves to supply balance pads must be present and adequate.
Control cover	Stone or lap inside face to remove raised burrs & dings.
Spool	Break sharp edges or dings.
Shoe	Stone to remove raised burrs or dings.

See Figure 6B-1

1. Install Lee Puget (13) using installation tool and gage.
2. Install orifices (10) and (11) in body. Make sure that the orifice (10) in the deeper bore extends past the wall of the valve bore and will not interfere with spools (25) or (33) action.
3. Install 1/16 pipe plug (27) into cover (12). Plug must extend below bore, so it will not interfere with spool (25).
4. Apply pipe sealant to the 1/8" pipe plugs (14) and install in the cover plate. Torque to 100 in.-lbs. (11.3 Nm)
5. If stroker housing was removed from control cover, install O-ring (12-1A) in housing and O-rings (12-3) and (12-5) on interface between parts. Slip servo shaft assembly through the bore, and install screws (12-4). Torque to 25 lbs-ft. (33.9 Nm). Check for free motion of shaft assembly. Remove shaft. Slip spools into their respective bores and check for free travel. If tight, it may be necessary to carefully hone the bore, till spools are free in bores. Position spool (25) in the bore with the slot, align the elongated hole centered over the slot and the grooved end toward the orifice (33).
6. Install O-ring (29) on nut (28) and the neutral bypass trimmer assembly into nut (28). Install nut (28) into cover. Adjust trimmer assembly until the land on end of assembly is centered in groove in spool (25), with elongated hole in spool centered on slot in cover. Hold in place and install nut (31), O-ring (32), plug (6) and O-ring (44).
7. Install O-ring (29) on plug (30) and install on other end of this bore.
8. Install spools (33) and (36) into the other cross-bore in the cover (12). The slotted end of spool (33) should be to the outside.
9. Install O-ring (29) on plug (35). Install spring (34) in plug and install plug in cover as shown.
10. Install O-rings (40) on fitting (41). Install piston (42) in bore of body (39). Install fitting (41) on body and install assembly in cover (12).
11. Install O-rings (44) and (45) on vent post (46). Install vent post in cover.
12. Install spring (47) and shoe (48) over vent post.
13. Install O-ring (19) on plug (18) and install in body (12).

See Figure 6C

14. Install O-ring (23-8) in groove of shear seal (23-5). Install shear seal with O-ring in the large hole on the servo link, on the servo shaft side. Be certain that the shear seal is sitting with the flange flush against the servo link surface.
15. Install needle bearing (23-9) over servo shaft and seat against the servo link. Install thrust washer (23-4) over needle bearing.

Note: The shear seal will fit in one position only. Otherwise one side will be held up by the lip of the servo link. Shear seal (23-5) must be installed to face against the cover plate. This shear seal differs from shear seal (23-7) in that the face surface is machined with two .094" (2.4 mm) radius scallops.

16. Install spool (12) in stroker body. Press dowel (9) into clamp (8) to .500" (12.7mm) dimension shown. Install screw (4) in clamp. Slip clamp into body to engage groove in spool (12). Slip servo shaft assembly (23) through the body and through the clamp, simultaneously engaging the pin on the servo arm with the slot in the spool, (25) ref. 6B-1.
17. Tighten the clamp only enough to hold the clamp snugly against the bushing, while permitting the shaft to turn in the clamp with light force.
18. Holding a flat plate against the ends of the spool bore, rotate the shaft clockwise and counterclockwise, causing spool (12) to travel from flush one side to flush the other side. Observe the position of the shear seal relative to the two 3/16 dowel holes in the cover. Position such that the overlap is equal on each side. Eliminate end play and torque screw (4) to 72 lbs-in, (8 Nm), locking the clamp to the shaft
19. Install spring guide (13) and spring (14) over screw (19). Install screw into screw (18). Adjust to 2" compressed length on spring (14). Install 1/4-20 nut (17) and tighten.
20. Insert spring assembly in body (2). Adjust for .308" ((7.82 mm) extension of spring guide beyond surface. Install O-ring (20) in body and locknut (15). Install locknut and acorn nut (16) on screw (18).
18. Install O-ring (20) in body and place assembly on stroker body, according to chart.
19. Using screws (24) bolt end connection (2) onto body (23).

20.. Install O-ring (20) in cover (28) and mount on housing on opposite side from centering assembly, with screws (29). Torque screws to 14 lbs-ft. (19 Nm).

<b>Pump rot. &amp; cont. mtg</b>	<b>Centering group location</b>
CW — A	See Fig. 6C
CW - B	Opposite to Fig. 6C
CCW - A	Opposite to Fig. 6C
CCW - B	See Fig. 6C

- 21 Install setscrew (30) in cover (28) till it contacts spool (12). Install nut (31), O-ring (32), plug (27) and O-ring (26) on setscrew and lock.
- 22. Install cover (21), cover screws (22) and O-ring (25). Torque screws to 14 lbs-ft. (19 Nm).
- 23. Place two spring washers (23-6), nested with the bent sections matching each other, into the large hole in the servo link,
- 24. Place washer (23-10) against the spring washers.
- 25. Install O-ring (23-8) into groove in the remaining shear seal (23-7). Note: This shear seal does not contain the two .094 radius scallops in the face. Place on top of washer, (23-10). Position shear seal to match the lip on the servo link.
- 26. If control is to be tested on pump, install on pump control pad with gasket (ref Fig. 6B-1 item 51), nylite washers (12), and screws (10). Torque to 30 lb. ft. (40.8 Nm). Install bypass check valves fittings, and lines.

**TEST**

Connect servo source, adjustable to 450 psi (31 bar), to control port on hydraulic stroker. Install a needle valve on the bypass valve exhaust port, connected to tank. Close the valve.

- 1. Set pump to zero stroke by adjusting minimum stop screw (30).
- 2. Apply servo pressure to signal port of stroker. Adjust pressure from minimum to maximum. Note the pressure at which pump just starts to stroke, and the pressure at which the pump reaches full stroke These pressures must be within the following values:

<b>Control Feature</b>	<b>Pressure Start</b>	<b>Pressure Full</b>
00	75± 15 psi (5.2± 1 bar)	335± 25 psi (23.1±1.7 bar)
01	75± 15 psi (5.2± 1 bar)	435± 25 psi (30± 1.7 bar)
02	100± 15 psi (6.9± 1 bar)	375± 25 psi (25.9± 1.7 bar)
03	150±15 psi (10.3±1 bar)	400± 25 psi (27.6± 1.7 bar)

- If pressures are incorrect, turn adjusting screw (18) to obtain correct pressure.
- 3. With minimum signal, pump shall return to zero stroke within 200 psi (13.8 bar) max. system pressure.
- 4. With full control signal pressure on control port, set screw (19) for full stroke, Lock adjustments and install acorn nut (16).
- 5. Increase and decrease control pressure between 0 and 450 psi (31 bar) several times . Pump stroke should follow control pressure smoothly and proportionally. Full to zero or zero to full stroke should be achieved in no more than two seconds. Adjust control pressure up to 90% stroke from zero stroke, then adjust down from full stroke to the same value. The control pressure at the two settings shall not vary more than 50 psi (3.4 bar) from each other.
- 6. With pump on zero stroke, turn brake trimmer screw CW and CCW while observing gage on brake port. Note the positions where the gage reading changes from case pressure to servo pressure to case pressure. Set and lock the adjustment midway between these two positions.
- 7. Place load on pump and stroke pump. The gage on the brake port should start to indicate servo pressure when the system pressure is between 2000 and 4500 psi (138 and 310 bar), with an increasing signal, and must return to case pressure before system pressure drops to 2000 psi (138 bar), on decreasing signal. Record both pressures.
- 8. Open the needle valve on the neutral bypass port. Measure and record leakage from this port with the pump on center at minimum psi, and with the pump off center, at 5000 psi.

**Maximum leakage with control on center:**

2.0 gpm (7.6 l/m)

**Minimum leakage with control on center:**

1.0 gpm (3.8 l/m)

**Maximum leakage with control off center:**

35 cu. in./min or .15 gpm (574 cm<sup>3</sup>/min. or 0.57 l/m)

9. Unload and stroke pump. Control should operate smoothly. Brake pressure should drop to case pressure each time control is on center, and it should indicate servo pressure as soon as input shaft is rotated on stroke.

10. Release control signal when pump is off center. Pump should return to center.

Repeat several times at different pressures from 200 to 5000 psi (13.8 to 345 bar)

11. Remove needle valve from bypass exhaust port and install exhaust line.

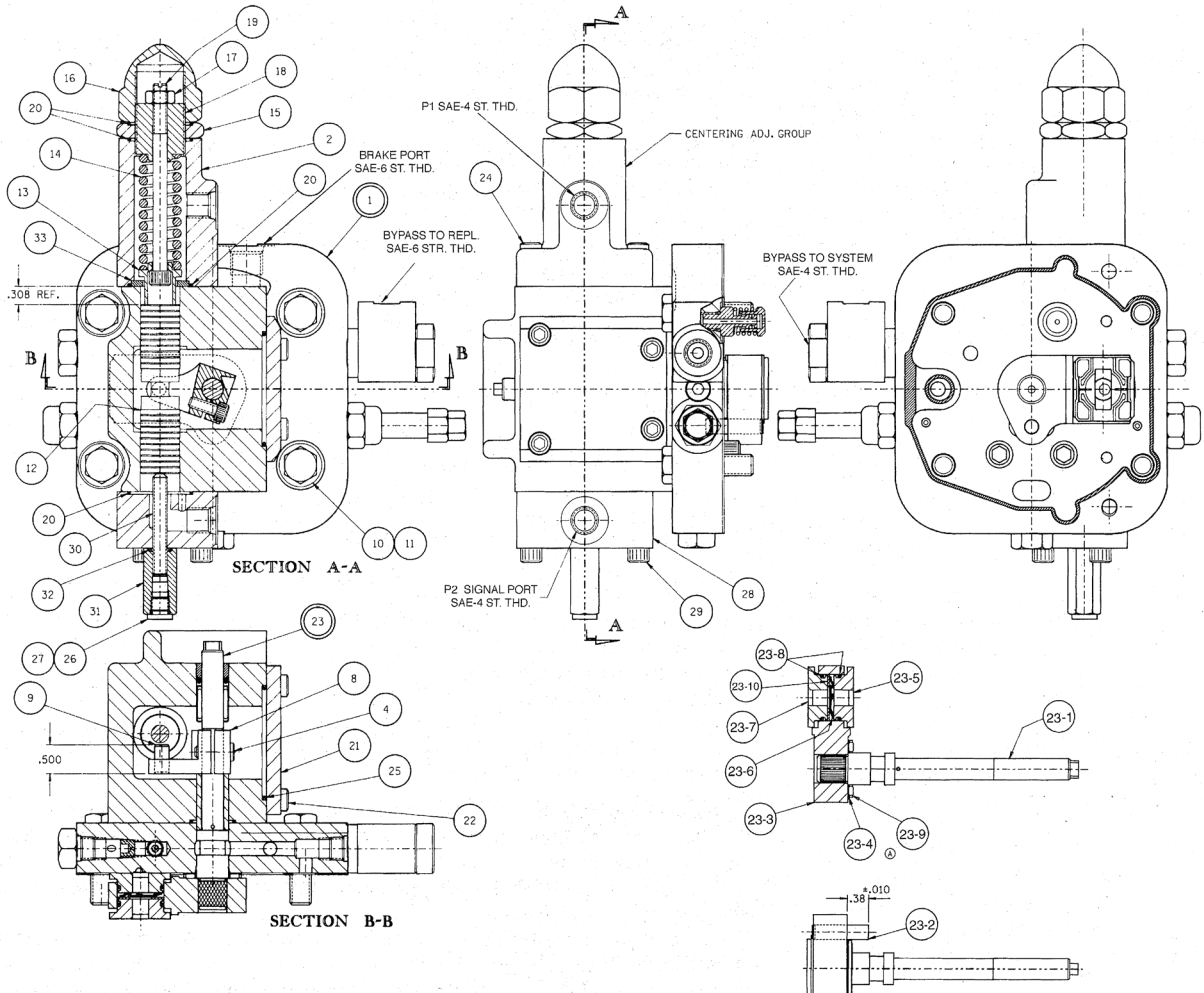

**FIGURE 6C**  
**HYDRAULIC STROKER**  
**WITH BRAKE AND BYPASS VALVE,**  
**ADJUSTABLE STOPS**

**PARTS LIST**

For Figure 6C - Hydraulic stroker with brake and bypass valve/adj. stops

S23-12296 - Feature 00, CW-A, CCW-B (75 - 350 PSI)

S23-12297 - Feature 00, CCW-A, CW-B (75 - 350 PSI)

ITEM	DESCRIPTION	Feature →	00	01	02	03
		PART NO.	QTY.	QTY.	QTY.	QTY.
1	Neutral bypass/brake . subassy (Fig. 6B-1)	S23-12335	1	1	1	1
2	End connection	033-53880	1	1	1	1
4	Screw, SHC, 10-24 x 1/2	358-10080	1	1	1	1
8	Clamp	033-72111	1	1	1	1
9	Pin	033-53894	1	1	1	1
10	Screw, HWHD 3/8-16 x 1 1/4	353-25018	4	4	4	4
11	Washer, Nyltite #37	631-45007	4	4	4	4
12	Spool	033-53439	1	1	1	1
13	Spring guide	033-53420	1	1	1	1
14	Spring Spring	033-54269 033-57486	1 -	- 1	1 -	1 -
15	Locknut	033-53877	1	1	1	1
16	Acorn nut, 7/8-14	327-25007	1	1	1	1
17	Hex nut	333-12614	1	1	1	1
18	Adjustment screw	033-53876	1	1	1	1
19	Slotted screw	033-53878	1	1	1	1
20	O-ring, 70 S-1 ARP 022	671-00022	4	4	4	4
21	Cover	031-53148	1	1	1	1
22	Screw, SHC 1/4-20 x 5/8	358-12100	4	4	4	4
23	Servo shaft assembly	S23-12497	(1)	(1)	(1)	(1)
23-1	Shaft	033-54841	1	1	1	1
23-2	Pin	033-71002	1	1	1	1
23-3	Link	033-70536	1	1	1	1
23-4	Washer	350-10141	1	1	1	1
23-5	Shear seal	033-71371	1	1	1	1
23-6	Washer, finger spring	350-10067	2	2	2	2
23-7	Shear seal	033-70525	1	1	1	1
23-8	O-ring 70 S-5 ARP 017	675-00017	2	2	2	2
23-9	Needle bearing	230-82141	1	1	1	1
23-10	Thrust washer	350-10064	1	1	1	1
24	Screw. SHC 1/4-20 x1	358-12160	4	4	4	4
25	O-ring, 70 S-1 ARP 133	671-00133	1	1	1	1
26	O-ring, 90 S-1 ARP 902	691-00902	1	1	1	1
27	Plug, 2HP5N-S	488-35046	1	1	1	1
28	Cover	033-53879	1	1	1	1
29	Screw, SHC 1/4-20 x 1 1/2	358-12200	4	4	4	4
30	Setscrew, 1/4-20 x 1 3/4	311-12220	1	1	1	1
31	Cover nut 1/4-20	033-91039	1	1	1	1
32	O-ring, 70 S-1 ARP 011	671-00011	1	1	1	1
33	Thrust washer	031-53421	1	1	1	1

**FEEDBACK FOR 700 SERIES  
HI-IQ SERVOVALVE CONTROL**

*S23-02345 Potentiometer feedback  
for 7E & 7G controls*

*S23-03278 D.C. R.V.D.T.feedback for  
7F & 7 H controls*

**DESCRIPTION**

The feedback controls provide an electrical signal corresponding to the pump displacement. For the potentiometer feedback, this signal is typically +/- 3.1 volts at full stroke, with a +/- 15 volt input. The RVDT has internal circuitry to power the RVDT and demodulate the output, converting the rotary input into a proportional D.C. output of +/- 2.3 volts at full stroke with +/- 15 volt input.

**DISASSEMBLY**

See Figure 7

Remove studs (12) by turning nuts (13) and remove cover (11), cover ring (33) if applicable, and housing (28).

2. Remove connector (22). Unsolder all wires from this connector.
3. Remove screw (27) attaching link (26) to cover.
4. Loosen the nut on the shaft lock (6), closest to the potentiometer or RVDT. Remove potentiometer or RVDT with mounting plate (7).
5. If complete disassembly is required, apply heat to the shaft lock (6), approx. 350°F. (176°C), to soften loctite and permit unscrewing from shaft.
6. Remove retaining ring (21) and press the shaft assembly through the valve body.
7. Examine shoes (1) and (4) for contamination in balance pads or excessive scratching on faces. Note: the two shoes are not identical and must be installed in the proper position on reassembly.

**REWORK OF WEAR PARTS**

Description	Rework
Servo plate face	Fine stone to remove raised burrs & dings
Shear seal	Fine stone to remove raised burrs & dings. Note: grooves to supply balance pads must be present and adequate.
Control cover	Stone or lap inside face to remove raised burrs & dings.

**PREPARATION FOR ASSEMBLY**

All parts are to be inspected and be free of material defects, dirt, scratches or any foreign material. All parts are to be cleaned with a suitable cleaning solvent and all cores and passages blown out with clean dry compressed air. After cleaning and inspection, all parts are to be covered with a light film of oil and should be protected from dirt and excessive handling until assembled onto the unit. During assembly, lapped and ground surfaces should be kept lubricated and protected from nicks or surface damage.

**ASSEMBLY**

1. Apply pipe sealant and Install plug (19) in body. Torque to 100 lbs-in. (11.3 Nm)
2. Install O-ring (2) in groove of shear seal (4). Install shear seal with O-ring in the large hole on the servo link, on the servo shaft side. Be certain that the shear seal is sitting with the flange flush against the servo link surface.

Note: The shear seal will fit in one position only. Otherwise one side will be held up by the lip of the servo link. Shear seal (4) must be installed to face against the cover plate (18). This shear seal differs from shear seal (1) in that the face surface is machined with two .094" (2.4 mm) radius scallops.

3. Install three thrust washers (17) over servo shaft and seat against the servo link.
4. Install O-ring (5) in the second groove from the end of the shaft, using installation tool T-1.
5. Install the servo shaft assembly into the cover plate (18).
6. Install retaining ring (21) into the groove of the servo shaft extending through the cover plate.
7. Place a drop of Loctite #271 on the threads on the end of the servo shaft. Install shaft lock (6) onto the servo shaft.
8. Using rosin flux solder, attach wires to potentiometer according to the wiring diagram, allowing sufficient length to wrap around once, plus 5" (127 mm) extra length.
9. Assemble brace (26) onto mounting plate (7), on side opposite counterbore, using screw (31) and locking nut (32). Hand tighten only.
10. Assemble RVDT or pot. into the counterbore on the mounting plate (7). Install mounting cleats and screws (8).

11. For RVDT assembly, slip sleeve (15) into clamp (6).

Note: Before installing the RVDT to servo shaft, align the scribe mark on the shaft with the scribe mark on the housing. Before installing the potentiometer, align the wiper, (terminal 4), with the center tap, (terminal 2) **Caution! limit electrical current through any terminal on the pot. to 8 ma maximum to avoid damage to resistance element!**

12. Install RVDT or potentiometer assembly into clamp (6), aligning the brace with the attaching hole in the cover, centering the servo arm and maintaining the alignment of the shaft as above. Tighten the clamp nut to 60 lbs-in. (6.8 Nm).
13. Install screw (27). Tighten this screw, and tighten screw (31).
14. Wrap wires once around the RVDT or pot. Feed wires through the drilling in the cover plate (18). Slip tubing (36) over pot. wiring bundle. Trim excess wiring.
15. Slide O-ring (23) and tubing (37) over wires. Solder wires to connector (22) per wiring diagram. Slip tubing (37) over each terminal and heat shrink in place.
16. Place a drop of Loctite #271 on one end of each threaded stud (12). Install acorn nut (13) on this end and tighten.
17. Install two O-rings (20) in housing (28).
18. For pot. assemblies, assemble clamp ring (33) and cover (11), to housing (28), with red dots to inside. Insert four studs with acorn nuts. Assemble indicator (34) with screw (15) to pot. (25). With servo arm centered, align indicator to match center dot on cover (11) as installed. Lock in position. Install housing assembly to cover plate (18). Torque to 48 in.-lbs. (5.42 Nm).
19. For RVDT assemblies, assemble cover (11) to housing and install on cover plate (18) using four studs (12) with nuts (13). Torque to 48 in.-lbs. (5.42 Nm).
20. Place two spring washers (3), nested with the bent sections matching each other, into the large hole in the servo link.
21. Place washer (10) against the spring washers.
22. Install O-ring (2) into groove in the remaining shear seal (1). Note: This shear seal does not contain the two .094" (2.4 mm) radius scallops in the face. Place on top of washer (10). Position shear seal to match the lip on the servo link.
23. Install on pump output control side, engaging servo arm between the spacer and the anti-backlash spring. Align control with housing dowels. Attach with screws (29), new Nyltite washers (30), and gasket (14). Torque screws to 30 lbs-ft. (40.8 Nm). Attach electrical connector to plug.

## FINAL ADJUSTMENT AND TEST

Note: Always have power off when loosening or tightening clamps on feedback pot., to avoid shorting out the electrical terminals and damaging the pot. or the electrical control. Caution! to avoid damage to RVDT check for correct polarity of D.C. signal to RVDT before applying power.

1. Remove housing from feedback control. Loosen clamps on feedback pot. or RVDT. Connect voltmeter between output terminal and common ground. Turn on power. Start pump and confirm that feedback polarity is correct, and servovalve is functioning correctly. (Pump may be controlled through its entire stroke range).
2. Set the displacement command to zero volts, and set the electronic zero adjustment to zero volts.
3. Rotate the feedback pot. or LVDT as necessary to bring the pump to zero stroke, as indicated by minimum system pressure and pump noise.
4. At this point, voltmeter reading should be less than +/-0.1 volts. If not, adjust the electronic zero adjustment till feedback voltage is zero volts, then re-adjust the feedback pot. or LVDT to bring the pump to zero stroke at zero volts feedback. If the wiper is within +/- 0.1 volts, the electronic zero adjustment can correct for this error.
5. Shut off pump and control power. Lock the feedback pot. or LVDT in place. If indicator is not aligned with center red dot, relocate and lock in position. Install housing assembly on control and torque nuts to 48 in.-lbs. (5.42 Nm).

**INSTALLATION OF ANTI-BACK-LASH SPRING**

1. Remove control. Remove screws holding servo plate to stem. Replace spacers with 033-57270 spacers, Attach one spacer and screw through servo plate, undercut end toward screw head.. Install spring 033-57271 over undercut on other spacer. Install screw through this end and attach through servo plate in the other hole, with the spring positioned as shown on SK-15045.

*SK-15045  
Installation of anti-backlash spring*

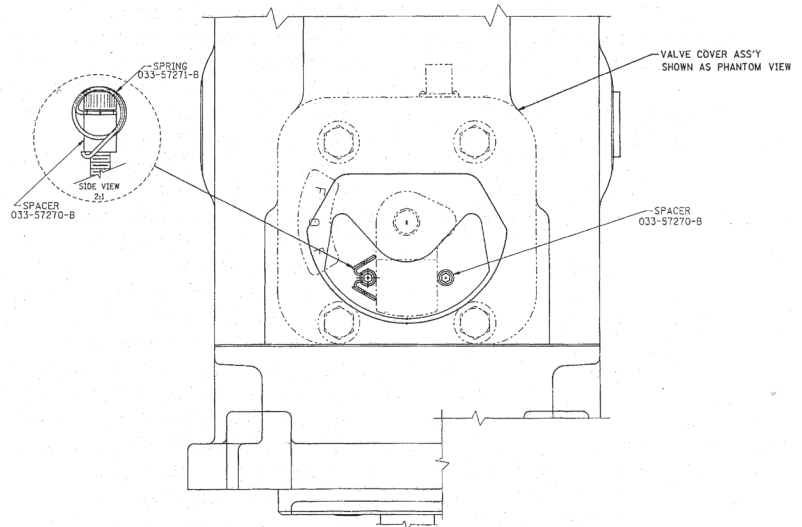

**PARTS LIST**

*For Figure 7 - Feedback for 700 series HI-IQ servovalve control*

*S23-02345*

*Potentiometer feedback for 7D & 7F control*

*S23-03278*

*D.C. RVDT feedback for 7E & 7G control*

ITEM	DESCRIPTION	PT. NO.	QTY.	QTY.
			S23-02345	S23-03278
1	Shear seal	033-70525	1	1
2	O-ring, 70 S-1 ARP 017	671-00017	2	2
3	Finger spring	350-10067	2	2
4	Shear seal	033-71371	1	1
5	O-ring, 70 S-1 ARP 013	671-00013	1	1
6	Shaft lock	735-80008	1	1
7	Mtg. plate	033-54458	1	-
	Mtg. plate (RVDT)	033-54486	-	1
8	Mtg. cleat with #4-40 screw	780-00008	3	3
10	Thrust washer	350-10064	1	1
11	Cover	033-54459	1	-
	Housing spacer	033-54533	-	1
12	Thd'd stud, #10-32 x 3	033-54535	4	-
	Thd'd stud, #10-32 x 3.55	033-54536	-	4
13	Nut, acorn 10-32	327-25003	4	4
14	Control cover gasket	033-91058	1	1
15	RVDT shaft sleeve	033-54534	-	1
16	Servo shaft assy.	S23-02346	1	1
17	Washer, hardened	350-10103	3	3
18	Control cover	033-54460	1	1
19	Hex flush plug 1/8" pipe	431-90204	1	1
20	O- ring, 70 S-1 ARP 035	671-00035	2	2
21	Ring, WT 5100-50	356-65070	1	1
22	Elec. connector	033-54466	1	1
23	O-ring, 70 S-1 ARP 015	671-00015	1	1
24	SHCS #4-40 x 1/4	358-02040	2	2
25	Potentiometer	035-44092	1	-
	RVDT, D.C.	788-20002	-	1
26	Brace	033-54461	1	1
27	SHCS #6-32 x 1/4	358-06040	1	1
28	Housing cover	033-54462	1	1
29	Screw, hwhd. 3/8-16 x 1-1/4	353-25018	4	4
30	Washer Nyltite #37	631-45007	4	4
31	SHCS #6-32 x 1	358-06160	1	1
32	Elastic stop nut	333-06010	1	1
33	Cover ring	033-54526	1	-
34	Plate, serial no.	030-55003	1	1
35	Screw, R.H. drive, #2 x 3/16 SS	320-10203	2	2
36	Tubing	739-20016	.5'	-
37	Tubing	739-20019	.2'	.2'
38	Indicator	035-45647	1	-
39	Rd. hd screw, #4-40 x 3/8	336-02061	1	-

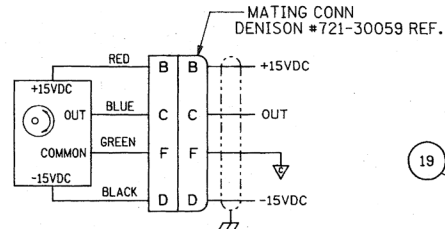
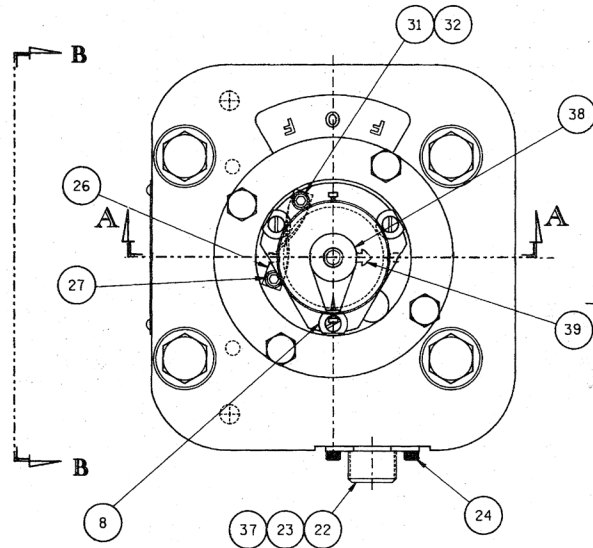

DC RVDT WIRING SCHEMATIC

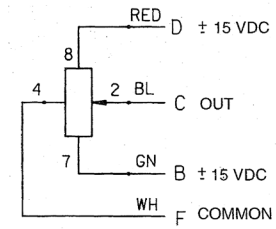

WIRING DIAGRAM

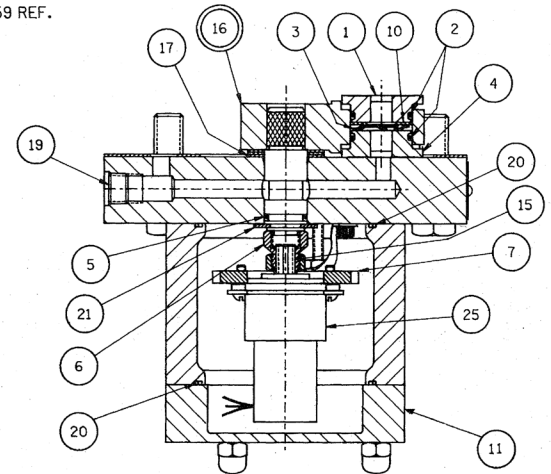

SECTION A-A  
DC R.V.D.T. (7E, 7G)

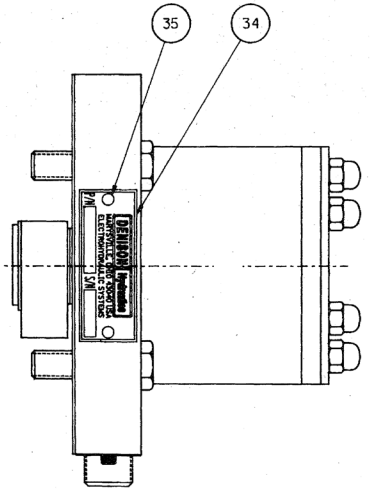

VIEW B-B

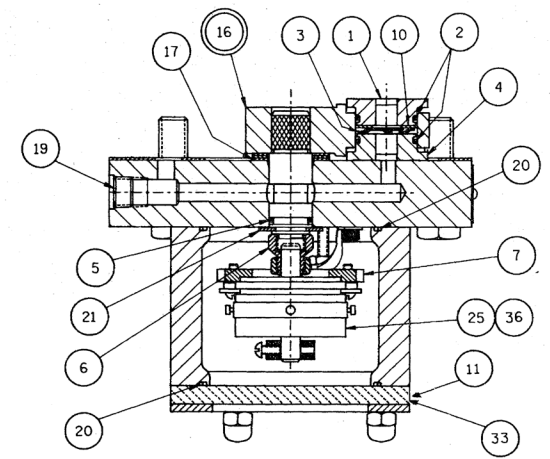
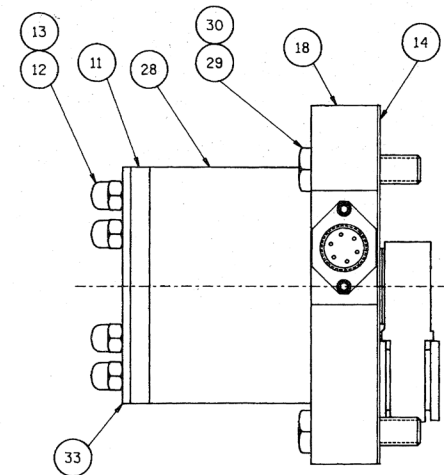

SECTION A-A  
POTENTIOMETER  
(7F, 7H)

FIGURE 7  
FEEDBACK FOR 700 SERIES HI IQ  
SERVO VALVE CONTROL

**8A HYDRAULIC STROKER CONTROL**

- S23-12268 (Feature 00 Pump)
- S23-12946 (Feature 00 "R" version)
- S23-12760 (Feature 01 Pump)
- S23-12630 (Feature 02 Pump)
- S23-12529 (Feature 03 Pump)
- S23-15065 (Feature 04 Pump)
- S23-12271 (Feature 0\* Motor "A" Input)
- S23-12378 (Feature 0\* Motor "B" Input)
- S23-12527 (Feature 1\* Motor "A" Input)
- S23-12526 (Feature 1\* Motor "B" Input)

**DESCRIPTION**

This control is used on both pump and motors. It consists of one spring centered spool in the control cover that is operated by modulation ports P1 or P2. The control may also be manually operated whenever the external control pressure is removed. The control, consisting of the stroking piston and the centering spring, positions the rotary servo proportionally to pilot or control pressure. With no external control pressure and the centering spring properly adjusted, the stroking piston will position the rotary servo: for pumps exactly at the zero stroke position, and for motors at the full stroke position.

**DISASSEMBLY**

See Figure 8A

1. Remove screws (2) from control.
2. Remove control from pump.
3. Examine servo plate for excessive scratching on surface. Note if orifices in stem are open. If servo plate is scratched or orifices appear to be plugged, remove plate and servo stem by removing two soc. setscrews from plate, then alternately loosening the two button hd. screws under the setscrews.
4. Remove retaining ring (4) and press the shaft assembly through the valve body.
5. Examine shoes (8) and (18) for contamination in balance pads and excessive scratching on shoe faces. Note the two shoes are not identical and must be installed in the proper position upon reassembly.
6. Remove the plug (13) with the stop assembly intact.
7. Remove the centering adjustment screw (23) with the spool assembly and stop assembly intact. Note: signal pressure setting is determined by the spring preload. Do not disassemble or change unless setting is incorrect.
8. Clean and examine all parts for breakage or evidence of abnormal wear.

**REWORK OF WEAR PARTS**

Description	Rework
Servo plate face	Fine stone to remove raised burrs & dings
Shear seal	Fine stone to remove raised burrs & dings. Note: grooves to supply balance pads must be present and adequate.
Control cover	Stone or lap inside face to remove raised burrs & dings.
Spool	Break sharp edges or dings.

**ASSEMBLY, 8A CONTROL**

See Figure 8A

All parts are to be inspected and be free of material defects, dirt, scratches, or any foreign material.  
 All parts are to be cleaned with a suitable cleaning solvent and all cores and passages blown out with clean dry compressed air.  
 After cleaning and inspection, all parts are to be covered with a light film of oil and should be protected from dirt and excessive handling until assembled onto the unit.  
 During assembly, lapped and ground surfaces should be kept lubricated and protected from nicks or surface damage.

1. Apply pipe sealant to the 1/8" pipe plug (12) and install in the cover plate. Torque to 100 lbs-in. (11.3 Nm)
2. Thread trimmer locknut (22) all the way onto trimmer screw (23). Slip back-up washer (21), small dia. first, onto trimmer screw and against locknut. Using a 3/4 - 16 hex nut, with a 1.030" (26.2mm) dia. x .030/.035" (0.76/0.89mm) deep c'bore, crimp the washer onto the stop. Washer must be free to rotate slightly. Remove crimping nut.

See Figure 8A-1

3. Compress spring (4) solid in order to remove spring set. This may be safely accomplished by using a 1/4" (6.35 mm) dia. bolt through the center of the spring.
4. Assemble retaining ring (2), guide (3), spring (4) and guide (6) onto spool (1).
5. Tighten nut (7) till it just starts to load the spring, then tighten the required number of turns to obtain desired preload, as indicated.

**SPRING SETTING**

Control Feature	Turns Past Contact
00 (PUMP)	2
01 (PUMP)	1-1/2
02 (PUMP)	2-1/2
03 (PUMP)	3-2/3
04 (PUMP)	2-5/6
0* (MOTOR)	2
1* (MOTOR)	6-1/6

See Figure 8A

6. Install locknut (5) onto spool and lock against nut (7) without changing adjustment.

7. Insert spool assembly (11), spring end first, into trimmer screw (23). Compress snap ring on the spool assembly until it snaps into internal groove inside trimmer screw. See that it is securely seated.
8. Thread spring stop locknut (24) all the way onto adjusting spring stop (25). Slip back-up washer (26), small diameter first, onto stop and against locknut. Using a 9/16-18 hex nut with a .810/.815" (20.6/20.7mm) dia. x .030-.035" (0.76-0.89mm) dp. c'bore, crimp washer onto stop. Washer must be free to rotate slightly. Remove the crimping nut.
9. Install O-ring (35) on plug (34) and insert into spring stop (25). Install O-ring (27) onto stop (25) and against washer (26).
10. Thread adjusting spring stop (25) into trimmer screw (23) until it just touches the spool assembly. Be sure spool assembly is against snap ring.
11. Determine the correct position of the spool assembly in the valve body. For 8A standard pump controls, and for 8A motor controls mounted on the "B" port side, the spool assembly is installed in the side of the control cap containing the 1/8" pipe plug (12). For controls used on P\*R pumps, and motor controls mounted on the "A" port side, the spool assembly is installed on the side opposite the 1/8" pipe plug (12), as shown in Fig. 8A.

Pump or Motor Model	Control Location	Spool Position Ref. Fig. 8A
P*P, P*V, P*S	"A" or "B"	Opposite shown
P6R, P7R, P8R	"A" or "B"	As shown
M*H, M*V	"A"	As shown
M*H, M*V	"B"	Opposite shown

12. Place O-ring (14) on trimmer screw (23) and thread assembly into the cover plate, as noted above.
13. Install O-ring (7) in groove of shear seal (8).
14. Install shear seal with O-ring in large hole on the servo link, on the servo shaft side. Be certain that the shear seal is sitting with the flange flush against the servo link surface.

Note: The shear seal will fit in one position only, otherwise one side will be held up by the lip of the servo link. Shear seal (8) must be installed to face against the cover plate (10). This shear seal (8) differs from shear seal (18) in that the face surface is machined with two .094" (2.4mm) radius scallops.

15. Install thrust bearing (9) over servo shaft and seat against the servo link.
16. Slip washer (33) over the servo shaft and against the thrust bearing.
17. Using installation tool T-1, install O-ring (5) in the second groove from the end of the shaft (1). Warm glyd ring (20) to make it pliable, and install over O-ring (5).
18. Install the servo shaft assembly in the cover plate (10). Pin must engage slot in spool assembly (11).
19. Install retaining ring (4) into the groove of the servo shaft extending thru the cover plate.
20. Install adjusting screw (15) in plug (13). Install O-ring (14) on plug. Thread adjusting screw in until it protrudes approximately 1/2" from top of plug (13). For motor controls, install two nuts (36) on the other end.
21. Thread cover nut (16) with O-ring (31) onto adjusting screw.
22. Install plug (28) and O-ring (29) into cover nut (16).
23. Install this assembly in body on the opposite side from the spool assembly (11).
24. Install nut (36) on adjusting screw (6). Thread adjusting screw into stop (25).
25. Install roll pins (30) into drilled holes in surface of cover. Caution! do not damage

face of cover.

26. Place two spring washers (17), nested with the bent sections matching each other, into the large hole in the servo link.
27. Place washer (32) against the spring washers.
28. Install O-ring (7) into groove in the remaining shear seal (18). Note: This shear seal does not contain the two .094" (2.4mm) radius scallops in the face. Place on top of washer, (32). Position shear seal to match the lip on the servo link.
29. If control is to be tested on pump, install control on pump control pad with gasket (19), nylite washers (3), and screws (2). Torque to 30 lb. ft. (40.8 Nm).

**8A CONTROL TEST SETUP**

1. Install stroking handle on the shaft.
2. Connect servo source, adjustable to 450 psi (31 bar), to control ports on hydraulic stroker through a 4-way valve. Center position must dump both ports to tank at min. pressure.

**8A PUMP CONTROL**

1. Rotate handle to check for free play. Turn spring stop adjustment in or out till it just contacts the spring and there is no free play. Lock in place. **Note: this adjustment is critical to accurate neutral adjustment!**
2. Turn trimmer screw to place input shaft on the zero stroke position. Set max. volume stops so that servo shaft link touches stop pins when handle is stroked each side of center. Lock in place.
3. Apply servo pressure to one port of stroker. Adjust pressure from minimum to maximum. Note the pressure at which pump just starts to stroke, and the pressure at which the pump reaches full stroke These pressures must be within the following values:

**PUMP CONTROL PRESSURE**

Control Feature	Pressure Start	Pressure Full
00	75± 15 psi (5.2± 1 bar)	335± 25 psi (23.1±1.7 bar)
01	75± 15 psi (5.2± 1 bar)	435± 25 psi (30± 1.7 bar)
02	100± 15 psi (6.9± 1 bar)	375± 25 psi (25.9± 1.7 bar)
03	150±15 psi (10.3±1 bar)	400± 25 psi (27.6± 1.7 bar)
04	75±15 psi (5.2± 1 bar)	250± 25 psi (17.2± 1.7 bar)

If pressures are incorrect, control may be disassembled and adjustment made to the spring preload. The following table may be used to determine adjustment required to the nuts retaining the spring:

**PUMP CONTROL SPRING ADJUSTMENT**

Control Feature	Pressure Change Per 1/6 Turn Adj.
00, 02, 03	6.8 psi (0.47 bar)
01	9.0 psi (0.62 bar)
04	4.6 psi (0.31 bar)

4. With minimum signal, pump shall return to zero stroke within 200 psi (13.8 bar) max.
5. Repeat test on opposite side of center.
6. Increase and decrease control pressure between 0 and 450 PSI (31 bar) several times . Pump stroke should follow control pressure smoothly and proportionally. Full to zero or zero to full stroke should be achieved in no more than two seconds. Adjust control pressure up to 50% stroke from zero stroke, then adjust down from full stroke to the same value. The control pressure at the two settings shall not vary more than 50 psi (3.4 bar) from each other.

**8A MOTOR CONTROL**

1. Set max. volume stop (6), on spring box end, to just contact the spool assembly. Lock in place. Back trimmer screw out to full stroke position. Lock in place.
2. Set min. volume stop (15) to limit travel to 25% of full stroke. (4 times the rpm at maximum displacement.) **Caution! do not exceed motor rated speed!** Lock in position.

3. Apply servo pressure to control port of stoker. Control port is on the same side as the trimmer adjustment. Adjust pressure from minimum to maximum. Note the control pressure at which motor just starts to de-stroke, and the control pressure at which the motor reaches 25% stroke. These pressures must be within the following values:

**MOTOR CONTROL PRESSURE**

<b>Control Feature</b>	<b>Pressure At Full</b>	<b>Pressure 25% Stroke</b>
0*	75± 15 psi (5.2± 1 bar)	250± 25 psi (17.2± 1.7 bar)
1*	250± 15 psi (17.2± 1 bar)	450± 25 psi (31± 1.7 bar)

If pressures are incorrect, control may be disassembled and adjustment made to the spring preload. The following table may be used to determine adjustment required to the nuts retaining the spring:

**MOTOR CONTROL SPRING ADJUSTMENT**

<b>Control Feature</b>	<b>Pressure Change Per 1/6 Turn Adj.</b>
0*, 1*	6.8 psi (0.47 bar)

4. Increase and decrease control pressure between 0 and 450 PSI (31 bar) several times. Motor stroke should follow control pressure smoothly and proportionally. Full to min. or minimum to full stroke should be achieved in no more than two seconds. Adjust control pressure down to 50% stroke from full stroke, then adjust up from min. stroke to the same value. The control pressure at the two settings shall not vary more than 50 psi (3.4 bar) from each other.

5. When control has satisfactorily passed test, remove stop assembly from control and set the two internal nuts to prevent adjustment of minimum stroke below 25% of stroke. Reassemble stop assembly on control.

**PARTS LIST**

For figure 8A - Hydraulic stroker control

S23-12268 (Feature 00 Pump)  
 S23-12946 (Feature 00 6R, 7R, 8R Pump)  
 S23-12760 (Feature 01 Pump)  
 S23-12630 (Feature 02 Pump)  
 S23-12529 (Feature 03 Pump)  
 S23-15065 (Feature 04 Pump)

S23-12271 (Feature 0\* Motor, A input)  
 S23-12378 (Feature 0\* Motor, B input)  
 S23-12527 (Feature 1\* Motor, A input)  
 S23-12526 (Feature 1\* Motor, B input)

Feature →			Pump 00	Pump 01	Pump 02	Pump 03	Pump 04	Motor 0*	Motor 1*
ITEM	DESCRIPTION	PT. NO.	QTY.	QTY.	QTY.	QTY.	QTY.	QTY.	QTY.
1	Servo shaft	S23-12267	1	1	1	1	1	1	1
2	Screw,W.H. 3/8-16 X 1.5	353-25074	4	4	4	4	4	4	4
3	Washer, Nyltite #37	631-45007	4	4	4	4	4	4	4
4	Ring, Truarc #5144-50	356-65070	1	1	1	1	1	1	1
5	O-ring, 70 S-5 ARP 012	675-00012	1	1	1	1	1	1	1
6	HHCS, 5/16-24 x 1"	307-13160	1	1	1	1	1	-	-
	Setscrew, 5/16-24 x 1.25"	312-13180	-	-	-	-	-	1	1
7	O-ring, 70 S-1 ARP 017	671-00017	2	2	2	2	2	2	2
8	Shear seal	033-71371	1	1	1	1	1	1	1
9	Bearing	230-82141	1	1	1	1	1	1	1
10	Cover	033-57999	1	1	1	1	1	1	1
11	Spool assy(Fig. 8A-1)	S23-12950	1	-	-	-	-	1	-
	Spool assy	S23-12951	-	-	-	-	-	-	1
	Spool assy	S23-12952	-	-	-	1	-	-	-
	Spool assy	S23-12953	-	-	1	-	-	-	-
	Spool assy	S23-12954	-	1	-	-	-	-	-
	Spool assy	S23-12956	-	-	-	-	1	-	-
12	Flush plug 1/8"	431-90204	1	1	1	1	1	1	1
13	SAE-8 plug	033-91027	1	1	1	1	1	1	1
14	O-ring, 90 S-1 ARP 908	691-00908	2	2	2	2	2	2	2
15	Setscrew, 5/16-24 X 2"	312-35062	1	1	1	1	1	-	-
	Setscrew, 5/16-24 X 2.50"	312-35063	-	-	-	-	-	1	1
16	Nut	033-91033	1	1	1	1	1	1	1
17	Finger spring	350-10067	2	2	2	2	2	2	2
18	Shear seal	033-70525	1	1	1	1	1	1	1
19	Gasket	033-91058	1	1	1	1	1	1	1
20	Glyd ring	679-00004	1	1	1	1	1	1	1
21	Washer	350-10139	1	1	1	1	1	1	1
22	Nut	033-91115	1	1	1	1	1	1	1
23	Center trimmer	033-91028	1	1	1	1	1	1	1
24	Locknut	492-15353	1	1	1	1	1	1	1
25	Stop	033-91026	1	1	1	1	1	1	1
26	Washer	350-10126	1	1	1	1	1	1	1
27	O-ring, 90 S-1 ARP 906	691-00906	1	1	1	1	1	1	1
28	Plug, 2P5N-S	488-35029	1	1	1	1	1	1	1
29	O-ring, 90 S-1 ARP 902	691-00902	1	1	1	1	1	1	1
30	Rollpin, 3/16 x .75"	325-12120	2	2	2	2	2	2	2
31	O-ring 70 S-1 ARP-013	671-00013	1	1	1	1	1	1	1
32	Washer	350-10064	1	1	1	1	1	1	1
33	Washer	350-10141	1	1	1	1	1	1	1
34	Piston	033-91099	1	1	1	1	1	1	1
35	O-ring, 70 S-1 ARP 010	671-00010	1	1	1	1	1	1	1
36	Nut, 5/16-24	335-13100	1	1	1	1	1	3	3

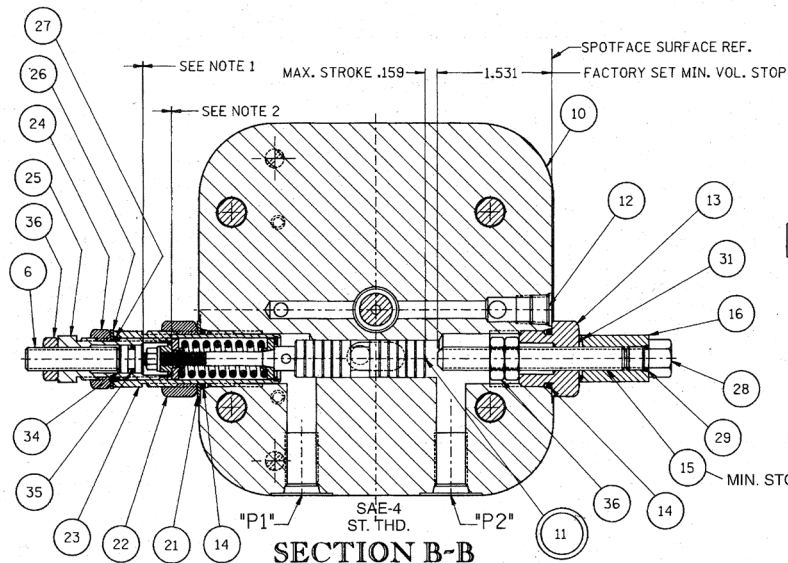

**SECTION B-B**  
MOTOR CONTROL "A" MTG. SHOWN

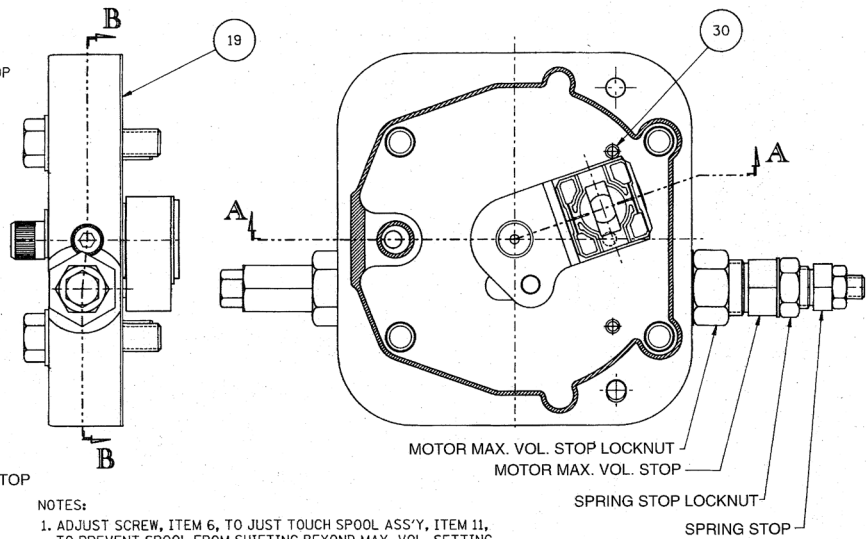

NOTES:  
 1. ADJUST SCREW, ITEM 6, TO JUST TOUCH SPOOL ASS'Y, ITEM 11, TO PREVENT SPOOL FROM SHIFTING BEYOND MAX. VOL. SETTING. IF PRESSURE IS APPLIED TO "P2" PORT.  
 2. ADJUST SPRING STOP, ITEM 25, TO JUST TOUCH SPOOL ASS'Y, ITEM 11, WITHOUT COMPRESSING SPRING.

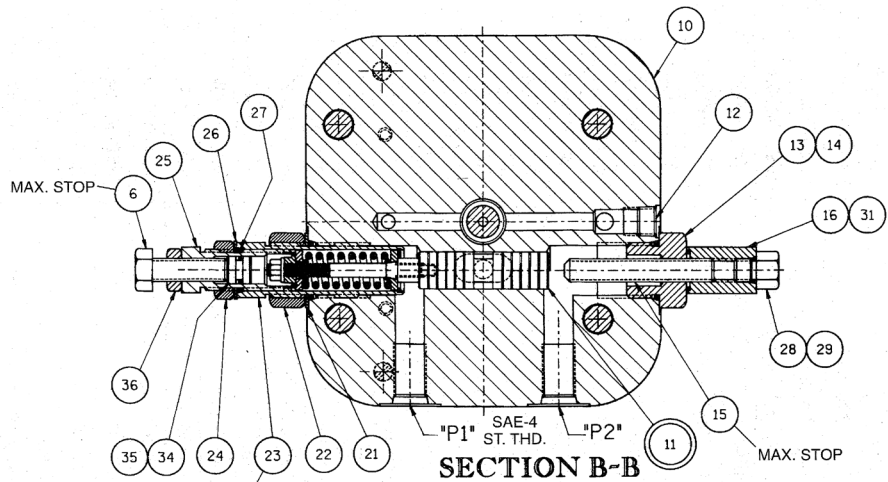

**SECTION B-B**  
PUMP CONTROL  
ZERO TRIMMER  
P6R, P7R, P8R SHOWN

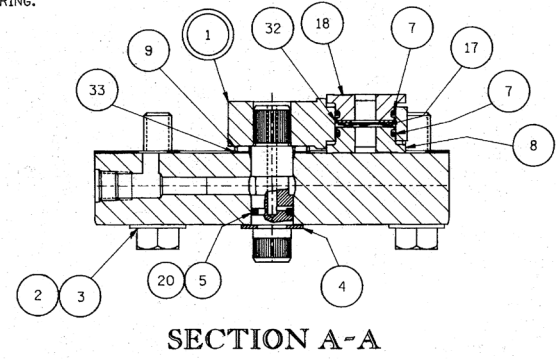

**SECTION A-A**

**FIGURE 8A**  
HYDRAULIC STROKER CONTROL

**PARTS LIST**

For Figure 8A-1 - Hydraulic/Electric stroker spool assemblies

S23-12950 Pump Feature 00, Motor Feature 0\*

S23-12951 Motor Feature 1\*

S23-12952 Pump Feature 03

S23-12953 Pump Feature 02

S23-12954 Pump Feature 01

S23-12956 Pump Feature 04, 9A  
Electric stroker

ITEM	DESCRIPTION	Assembly→ PT. NO.	S23-12950	S23-12951	S23-12952	S23-12953	S23-12954	S23-12956
			QTY.	QTY.	QTY.	QTY.	QTY.	QTY.
1	Spool	S23-12949	1	1	1	1	1	1
2	Retainer	033-91022	1	1	1	1	1	1
3	Guide	033-91426	1	1	1	1	1	1
4	Spring	225-92098	1	1	1	1	-	-
	Spring	225-92101	-	-	-	-	1	-
	Spring	225-92100	-	-	-	-	-	1
5	Nut	340-00057	1	1	1	1	1	1
6	Guide	033-91426	1	1	1	1	-	1
	Guide	033-91325	-	-	-	-	1	-
7	Nut	033-91424	1	1	1	1	1	1

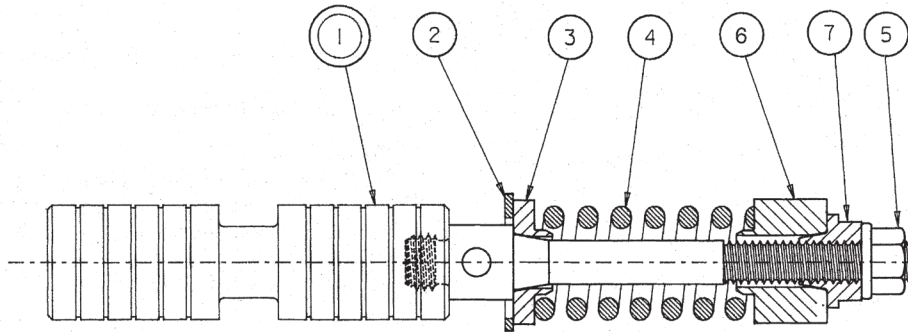

**SPRING SETTING**

ASSEMBLY	TURNS PAST CONTACT
S23-12950	2
S23-12951	6-1/6
S23-12952	3-2/3
S23-12953	2-1/2
S23-12954	1-1/2
S23-12956	2-5/6

**FIGURE 8A-1  
SPOOL ASSEMBLIES FOR 8A AND 9A STROKER**

**8C HYDRAULIC STROKER  
W/BRAKE & BYPASS VALVE**

S23-12820 (Feature 00)

**DESCRIPTION**

The 8C control incorporates the brake and neutral bypass functions into the body of the proportional hydraulic stroker. A brake spool, when energized, connects the brake port to servo pressure. When de-energized, a spring shifts the spool, connecting the brake port to tank. Servo pressure releases the brake. Another port, located on the end of the brake valve, is closed by the energizing of the brake spool. When de-energized, this port dumps both pump system ports to the replenishing source, thus bypassing the small flow generated by slight errors on zero position. The operation is controlled in this manner: A metered servo signal is applied to the brake spool. This signal is dumped when a slot in the servo plate aligns with a passage connecting to this spool. This occurs when the pump is on zero stroke. Another signal is applied to a spool adjacent to the brake spool. This metered signal is connected to a port controlled by the input command spool. This port is set to open to tank when the input command is at zero stroke. The brake spool is thus de-energized when BOTH the pump cam is at zero stroke and the rotary servo is at zero command. If the pump is on stroke or the input is on stroke, the brake spool is energized. For a description of the hydraulic stroker, refer to the 8A control description.

**DISASSEMBLY**

See Figure 8C

1. Remove screws (2) from control.
2. Remove control from pump.
3. Examine servo plate for excessive scratching on surface. Note if orifices in stem are open. If servo plate is scratched or orifices appear to be plugged, remove plate and servo stem by removing two soc. setscrews from plate, then alternately loosening the two button hd. screws under the setscrews.
4. Remove retaining ring (4) and press the shaft assembly through the valve body.
5. Examine shoes (8) and (18) for contamination in balance pads and excessive scratching on shoe faces. Note the two shoes are not identical and must be installed in the proper position upon reassembly.
6. Remove the brake trimmer stop assembly (13) intact.
7. Remove the center trimmer screw (23) with the spool assembly and stop assembly intact. Note: signal pressure setting is determined by the spring preload. Do not disassemble or change unless setting is incorrect.
8. Remove tubing assembly (74). Remove bypass valve body (42) with fitting (44) and piston (45). Remove elbow (73) with .0135 orifice (37) and fitting (38). Remove spools (31) and (39).
9. Remove shoe (50), and spring (49).
10. Examine orifices (16) and (29) in body for contamination. Examine passages in body for free flow.
11. Clean and examine all parts for breakage or evidence of abnormal wear.

**REWORK OF WEAR PARTS**

Part Description	Rework
Servo plate face	Fine stone to remove raised burrs & dings
Shear seal	Fine stone to remove raised burrs & dings. Note: grooves to supply balance pads must be present and adequate.
Control cover	Stone or lap inside face to remove raised burrs & dings.
Spool	Break sharp edges or dings.
Shoe	Stone to remove raised burrs or dings.

**ASSEMBLY**

All parts are to be inspected and be free of material defects, dirt, scratches, or any foreign material. All parts are to be cleaned with a suitable cleaning solvent and all cores and passages blown out with clean dry compressed air. After cleaning and inspection, all parts are to be covered with a light film of oil and should be protected from dirt and excessive handling until assembled onto the unit. During assembly, lapped and ground surfaces should be kept lubricated and protected from nicks or surface damage.

See Figure 8C

1. Install .031" orifices (29), checking to see that they clear the bore. Install the .018" orifice (16) in body.
2. Apply pipe sealant and install 1/16 pipe plugs (28) in body as shown. Torque to 25 in.-lbs. (2.8 Nm)
3. Apply pipe sealant to the 1/8" pipe plugs (12) and install in the cover plate. Torque to 100 in.-lbs. (11.3 Nm)
4. Thread trimmer locknut (22) all the way onto center trimmer screw (23). Slip backup washer (21), small dia. first, onto trimmer screw and against locknut. Using a 3/4-16 hex nut, with a 1.030" (26.2mm) dia. x .030/.035" (0.76/0.89mm) deep c'bore, crimp

the washer onto the stop. Washer must be free to rotate slightly. Remove crimping nut.

See Figure 8C-1

5. Compress spring (4) solid in order to remove set. This may be safely accomplished using a 1/4" (6.35 mm) dia. bolt, nut and washers.
6. Assemble retaining ring (2), guide (3), spring (4) and guide (9) onto spool (1).
7. Tighten nut (6) till it just starts to load the spring, then tighten the required number of turns to obtain desired preload, as indicated:
8. Install locknut (5) onto spool and lock against nut (6) without changing adjustment.

**SPRING SETTING**

CONTROL FEATURE	TURNS PAST CONTACT
00	2
04	2-5/6

9. Install spool (7) onto other end of spool assembly (1). Install nuts (8) and tighten till spool has from .001 to .003" (.025 to .076 mm) clearance. (Barely free to rotate without binding). Lock nuts together and re-check spool fit.

See Figure 8C

10. Insert spool assembly (11), spring end first, into center trimmer screw (23). Compress snap ring on the spool assembly until it snaps into internal groove inside trimmer screw. See that it is securely seated.
11. Thread spring stop locknut (24) all the way onto adjusting spring stop (25). Slip back-up washer (26), small diameter first, onto stop and against locknut. Using a 9/16-18 hex nut with a .810/.815" (20.6-20.7mm) dia. x .030-.035" (0.76-0.89mm) dp. c'bore, crimp washer onto stop. Washer must be free to rotate slightly. Remove the crimping nut.
12. Install O-ring (35) on plug (34) and insert into spring stop (25). Install O-ring (27) onto stop (25) and against washer (26).
13. Thread spring adjustment stop (25) into trimmer screw (23) until it just touches the spool assembly. Be sure spool assembly is against snap ring.
- 14 Place O-ring (14) on trimmer screw (23) and thread assembly into the larger cross-bore in the cover plate. Install from the end which contains the 1/16" pipe plug.
15. Install nut (36) on adjusting screw (6). Thread adjusting screw into stop (25).
16. Thread locknut (8) all the way onto guide (1). Slip back-up washer (7), small dia. first, onto guide and against locknut. Using a 3/4-16 hex nut, with a 1.030" (26.2mm) dia. x .030/.035" (0.76/0.89mm) deep c'bore, crimp the washer onto the stop. Washer must be free to rotate slightly. Remove crimping nut.
17. Install stop (2) into guide. Install O-ring (9) on nut (3) and install over stop (2). Install O-ring (10) over plug (11). Install plug in nut (3).
18. Install O-rings (4,5, and 6) on guide (1). Lubricate O-rings and carefully insert guide into bore and over spool on opposite side from the trimmer screw.
19. Install spools (31) and (39) into the other cross-bore in the cover (10). The slotted end of spool (31) should be to the outside.
20. Install O-ring (27) on plug (38). Install spring (37) in plug and install plug in cover as shown.
21. Install O-rings (43) on fitting (44). Install piston (45) in bore of body (42). Install O-ring (72) on plug (71) and install in body (42). Install seals (70) on body (42). Install fitting (44) on body and install assembly in cover (10).
22. Install rollpins (30) in cover, being careful not to damage the cover surface.
23. Install O-rings (46) and (47) on vent post (48). Install vent post in cover.
24. Install spring (49) and shoe (50) over vent post.
25. Install O-ring (7) in groove of shear seal (8).
26. Install shear seal with o-ring in large hole on the servo link, on the servo shaft side. Be certain that the shear seal is sitting with the flange flush against the servo link surface.
27. Install thrust bearing (9) over servo shaft and seat against the servo link.

See Figure 8C-2

See Figure 8C

28. Slip washer (33) over the servo shaft and against the thrust bearing.
29. Using installation tool T-1, install O-ring (5) in the second groove from the end of the shaft (1). Warm glyd ring (20) to make it pliable, and install over O-ring (5).
30. Install the servo shaft assembly in the cover plate (10). Pin must engage slot in spool assembly (11).
31. Install retaining ring (4) into the groove of the servo shaft extending thru the cover plate.
32. Place two spring washers (17), nested with the bent sections matching each other,

Note: The shear seal will fit in one position only, otherwise one side will be held up by the lip of the servo link. Shear seal (8) must be installed to face against the cover plate (10). This shear seal (8) differs from shear seal (18) in that the face surface is machined with two .094" (2.4mm) radius scallops.

into the large hole in the servo link.

- 33. Place washer (32) against the spring washers.
- 34. Install O-ring (7) into groove in the remaining shear seal (18). Note: This shear seal does not contain the two .094 radius scallops in the face. Place on top of washer, (32). Position shear seal to match the lip on the servo link.
- 35. If control is to be tested on pump, install on pump control pad with gasket (19), nytlite washers (3), and screws (2). Torque to 30 lb. ft. (40.8 Nm). Install bypass check valves fittings, and lines.

**TEST**

Install stroking handle on the shaft.  
 Connect servo source, adjustable to 450 psi (31 bar), to control ports on hydraulic stroker through a 4-way valve. Center position must dump both ports to tank at min. pressure.

Install a needle valve on the bypass valve exhaust port, connected to tank. Close the valve.

Install a 1000 psi (70 bar) gage in the brake port.

Rotate handle to check for free play. Turn spring stop adjustment in or out till it just contacts the spring and there is no free play. Lock in place. Note: this adjustment is critical to accurate neutral adjustment!

- 1. Start prime mover and adjust system relief valve for 5000 psi (345 bar).
- 2. Turn centering trimmer screw to place input shaft on the zero stroke position. Stroke pump to full and release, on both sides of center. Pump shall return to zero stroke within 200 psi (13.8 bar) max.
- 3. With pump on zero stroke, turn brake trimmer screw CW and CCW while observing gage on brake port. Note the positions where the gage reading changes from case pressure to servo pressure to case pressure. Set and lock the adjustment midway between these two positions.
- 4. Set max. volume stops so that servo shaft link touches stop pins when handle is stroked each side of center. Lock in place.
- 5. Apply servo pressure to one port of stroker. Adjust pressure from minimum to maximum. Note the pressure at which pump just starts to stroke, and the pressure at which the pump reaches full stroke These pressures must be within the following values:

If pressures are incorrect, control may be disassembled and adjustment made to the

**PUMP CONTROL PRESSURE**

CONTROL FEATURE	PRESSURE START	PRESSURE FULL
00	75± 15 psi (5.2± 1 bar)	335± 25 psi (23.1±1.7 bar)
04	75±15 psi (5.2± 1 bar)	250± 25 psi (17.2± 1.7 bar)

spring preload. The following table may be used to determine adjustment required to the nuts retaining the spring:

**PUMP CONTROL SPRING ADJUSTMENT**

6. With minimum signal, pump shall return to zero stroke within 200 psi (13.8 bar)

CONTROL FEATURE	PRESSURE CHANGE PER 1/6 TURN ADJ.
00	6.8 psi (0.47 bar)
04	4.6 psi (0.31 bar)

max.

- 7. Repeat test on opposite side of center.
- 8. Increase and decrease control pressure between 0 and 450 PSI (31 bar) several times . Pump stroke should follow control pressure smoothly and proportionally. Full to zero or zero to full stroke should be achieved in no more than two seconds. Adjust control pressure up to 50% stroke from zero stroke, then adjust down from full stroke to the same value. The control pressure at the two settings shall not vary more than 50 psi (3.4 bar) from each other.
- 9. Stroke pump CW. The gage on the brake port should start to indicate servo pressure when the system pressure is between 2000 and 4500 psi (138 and 310 bar), with an increasing signal, and must return to case pressure before system pressure drops to 2000 psi (138 bar), on decreasing signal. Repeat by rotating input shaft CCW. Record both pressures for each rotation of the servo input shaft.
- 10. Open the needle valve on the neutral bypass port. Measure and record leakage from this port with the pump on center at minimum psi, and with the pump off center, at 5000 psi (345 bar).

**Maximum leakage with control on center:**

2.0 gpm (7.6 l/m)

**Minimum leakage with control on center:**

1.0 gpm (3.8 l/m)

**Maximum leakage with control off center:**

35 cu. in/min or .15 gpm (574 cm<sup>3</sup>/min. or 0.57 l/m)

11. Stroke pump above and below center. Control should operate smoothly. Brake pressure should drop to case pressure each time control is on center, and it should indicate servo pressure as soon as input shaft is rotated CW or CCW from center, per step 9 above.

12. Release control when pump is off center. Pump should return to center. Repeat several times in each direction and at different pressures from 200 to 5000 psi (13.8 to 345 bar).

13. Remove needle valve from bypass exhaust port and install exhaust line.

**PARTS LIST**

For Figure 8C - Hydraulic stroker  
with brake and bypass valve

S23-12820  
Feature 00

ITEM	DESCRIPTION	Feature →	00	04
		PT. NO.	QTY	QTY.
1	Servo Shaft	S23-12267	1	1
2	Screw, W.H., 3/8-16 x 1.5"	353-25074	4	4
3	Washer, Nyltite #37	631-45007	4	4
4	Ring, Truarc #5144-50	356-65070	1	1
5	O-ring, 70 S-5 ARP 012	675-00012	1	1
6	Screw, HHC 5/16-24 x 1"	307-13160	1	1
7	O-ring, 70 S-1 ARP 017	671-00017	2	2
8	Shear Seal	033-71371	1	1
9	Bearing	230-82141	1	1
10	Cover	033-91433	1	1
11	Spool Assy (Fig. 8C-1)	S23-12911	1	-
	Spool Assy	S23-12935	-	1
12	Hex plug, 1/8" Flush	431-90204	3	3
13	Brake Trimmer (Fig. 8C-2)	S23-12921	1	1
14	O-ring, 90 S-1 ARP 908	691-00908	1	1
15	O-ring, 70 S-5 ARP 015	675-00015	1	1
16	Orifice, .018	035-19092	1	1
17	Finger Spring	350-10067	2	2
18	Shear seal	033-70525	1	1
19	Gasket	033-91058	1	1
20	Glyd ring	679-00004	1	1
21	Washer, Backup	350-10139	1	1
22	Nut	033-91115	1	1
23	Center Trimmer	033-91028	1	1
24	Locknut	492-15353	1	1
25	Stop	033-91026	1	1
26	Washer	350-10126	1	1
27	O-ring, 90 S-1 ARP 906	691-00906	3	3
28	Plug, 1/16" Flush	431-90104	4	4
29	Orifice, .031	035-91757	2	2
30	Rollpin, 3/16" x .75"	325-12120	2	2
31	Spool	033-70999	1	1
32	Washer	350-10064	1	1
33	Washer	350-10141	1	1
34	Piston	033-91099	1	1
35	O-ring, 70 S-1 ARP 010	671-00010	1	1
36	Nut, 5/16-24	335-13100	1	1
37	Orifice, .0135	033-91758	1	1
38	Fitting	492-15375	1	1
39	Spool	033-91685	1	1
40	Spring	033-70992	1	1
41	Dowel Pin, 1/16 x .50	324-30026	1	1
42	Body	033-91090	1	1
43	O-ring, 90 S-1 ARP 016	691-00016	1	1
44	Fitting	033-91700	1	1
45	Piston	033-91699	1	1
46	O-ring, 90 S-1 ARP 902	691-00902	1	1

**PARTS LIST**

*For Figure 8C - Hydraulic stroker  
with brake and bypass valve*

*S23-12820  
Feature 00*

		Feature →	00	04
ITEM	DESCRIPTION	PT. NO.	QTY	QTY.
47	O-ring, 70 S-1 ARP 006	671-00006	1	1
48	Vent post	033-70995	1	1
49	Spring	225-92044	1	1
50	Shoe	033-91701	1	1
68	O-ring, 90 S-1 ARP 904	691-00904	1	1
69	Seat, spring	033-91686	1	1
70	Tetraseal	691-10013	2	2
71	Plug, SAE-3	488-35049	1	1
72	O-ring, 90S-1 ARP 903	691-00903	1	1
73	Fitting, elbow	033-91702	1	1
74	Tube assembly	S23-15202	1	1
75	Tee, st. thd run, SAE-6	497-15008	1	1
76	Reducer	492-15376	1	1
77	Nut	492-10012	1	1

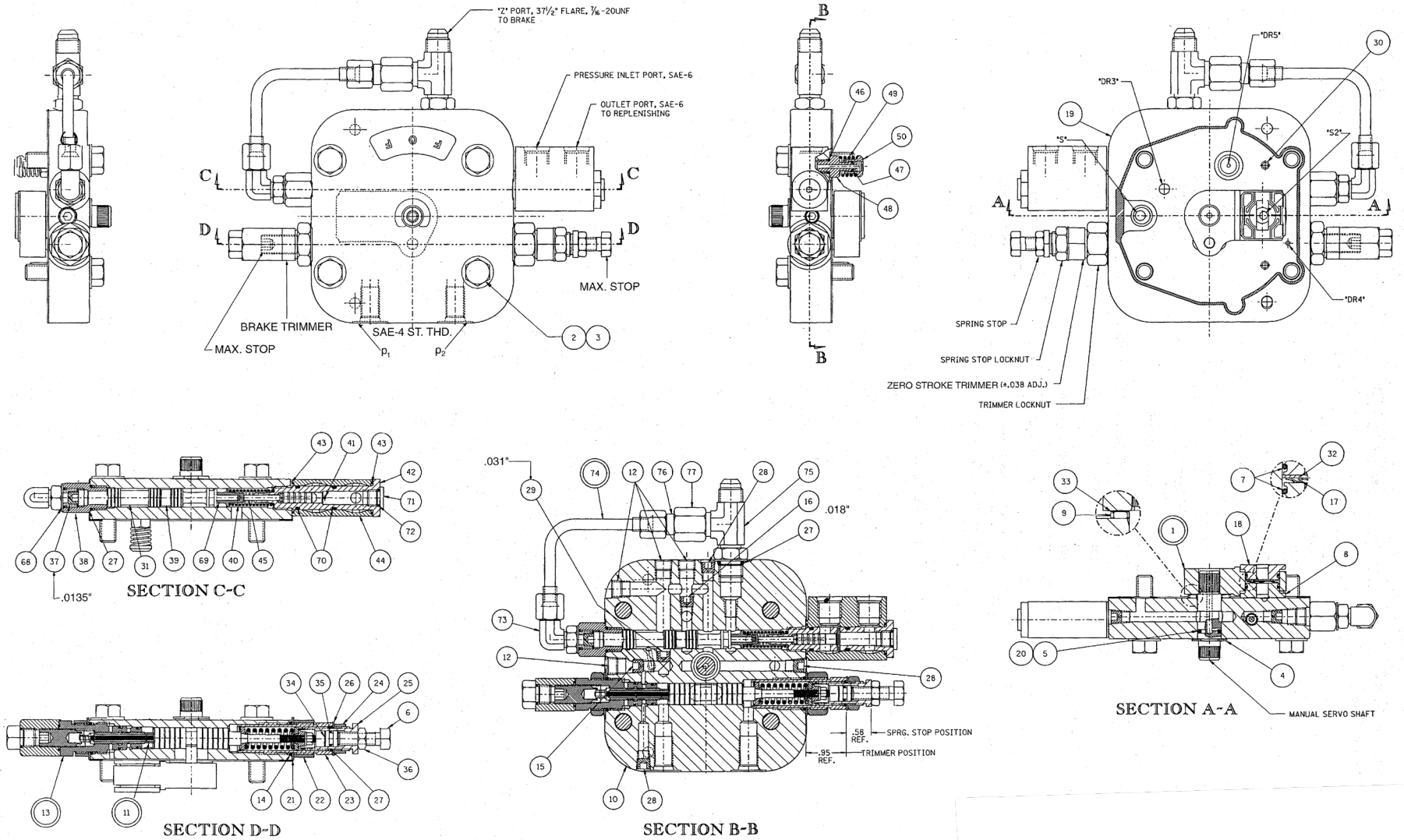

**FIGURE 8C**  
**HYDRAULIC STROKER WITH BRAKE AND**  
**BYPASS VALVE**

**PARTS LIST**

For Figure 8C-1 - Spool assemblies for 8C and 9C stroker w/brake and bypass valve

Assembly S23-12911 8C Feature 00

Assembly S23-12935 8C Feature 04, 9C Electric stroker

ITEM	DESCRIPTION	Assembly →	S23-12911	S23-12935
		PT. NO.	QTY.	QTY.
1	Spool	S23-12910	1	1
2	Retainer	033-91022	1	1
3	Guide	033-91426	1	1
4	Spring	225-92098	1	-
	Spring	225-92100	-	1
5	Nut	340-00057	1	1
6	Nut	033-91424	1	1
7	Spool	033-91434	1	1
8	Nut	340-00058	2	2

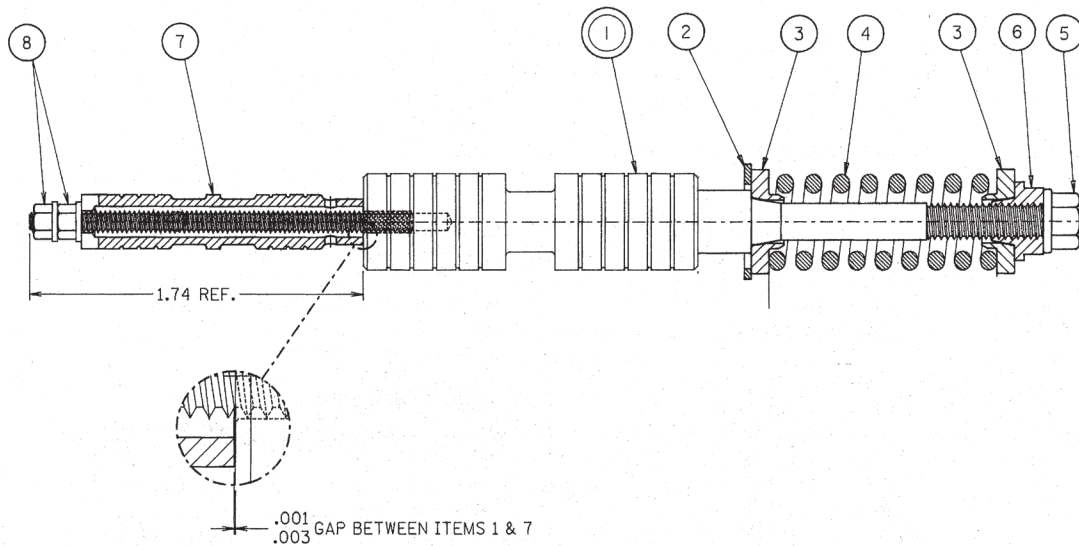

**SPRING SETTING**

ASSEMBLY	TURNS PAST CONTACT
S23-12911	2
S23-12935	2-5/6

**FIGURE 8C-1  
SPOOL ASSEMBLIES FOR 8C AND 9C STROKER W/BRAKE AND BYPASS VALVE**

**PARTS LIST**

For Figure 8C-2 Brake trimmer for  
8C & 9C stroker w/brake and  
bypass valve

Assembly S23-12921

ITEM	DESCRIPTION	PT. NO.	QTY
1	Guide	033-91452	1
2	Stop	033-91462	1
3	Nut	033-91463	1
4	O-ring, 70 S-1 ARP 012	671-00012	1
5	O-ring, 70 S-1 ARP 013	671-00013	1
6	O-ring 90 S-1 ARP 908	691-00908	1
7	Washer, Backup	350-10139	1
8	Locknut, 3/4-16	492-15364	1
9	O-ring, 70 S-1 ARP 014	671-00014	1
10	O-ring, 90 S-1 ARP 904	691-00904	1
11	Plug, Parker 4-P5 N-S	488-35013	1

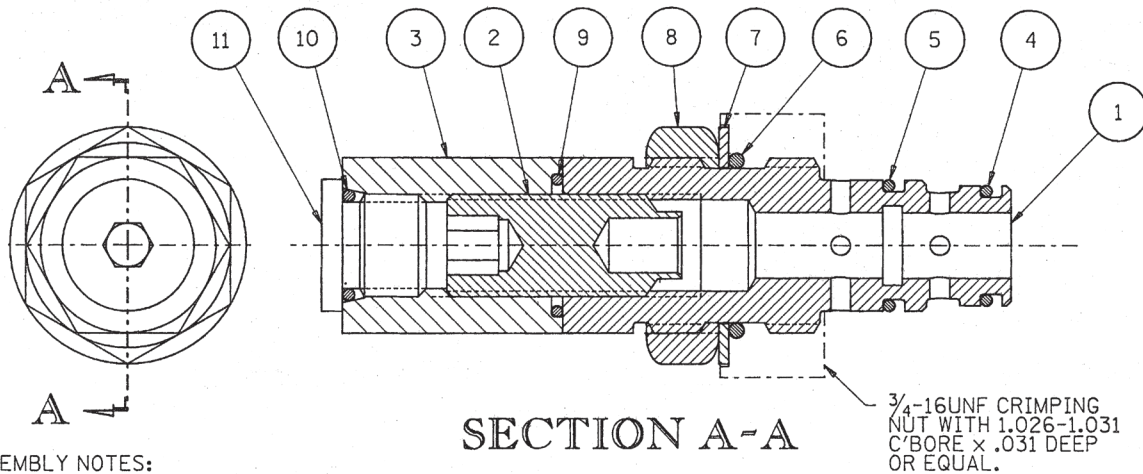

**ASSEMBLY NOTES:**

1. CRIMPING OF BACK-UP WASHER, ITEM 7, ONTO GUIDE, ITEM 1.
- 1A. THREAD LOCKNUT, ITEM 8, ALL THE WAY ONTO GUIDE.
- 1B. SLIP BACK-UP WASHER, SMALL DIA. FIRST ONTO GUIDE AND AGAINST LOCKNUT.
- 1C. USING CRIMPING NUT, CRIMP WASHER ONTO GUIDE. WASHER MUST BE FREE TO ROTATE SLIGHTLY. REMOVE CRIMPING NUT.

**FIGURE 8C-2  
BRAKE TRIMMER FOR 8C AND 9C STROKER  
WITH BRAKE AND BYPASS VALVE**

**9A ELECTRIC STROKER**

*S23-12667 Feature 00 cross ctr. Pump*

*S23-12957 Feature 01 cross ctr. Pump*

*S23-12940 Feature 00 cross ctr.  
P6R,P7R,P8R*

*S23-12734 Feature 00 CW-A,CCW-B-  
Pump)*

*S23-12733 Feature 00 CCW-A,CW-B-  
Pump)*

*S23-15050 Feature 0\* A Mtg. Motor)*

*S23-15051 Feature 0\* B Mtg. Motor)*

**DESCRIPTION**

The 9A consists of one or two electric proportional pressure control valves mounted on the 8A cover to provide the pilot pressure signal. It is a simple electrohydraulic control with comparable performance to the 5A in most applications. Refer to 8A for stroker description.

The Jupiter 900 Driver Card has been developed to accompany the 9A control with 24V coil.

**DISASSEMBLY**

See Figure 9A

1. Disconnect connector (46) from coil (52).
2. Remove proportional valve or valves from block (39). Do not attempt disassembly of the valve, other than replacement of the coil, (52) and external O-rings, (38-a), (38-b) and (38-c).
3. Remove screws (2) from control. Remove proportional valve block (39) from control. Remove control from pump.
4. Examine orifices (37) for plugging or contamination. Examine servo plate for excessive scratching on surface. Note if orifices in stem are open. If servo plate is scratched or orifices appear to be plugged, remove plate and servo stem by removing two soc. setscrews from plate, then alternately loosening the two button hd. screws under the setscrews.
5. Remove retaining ring (4) and press the shaft assembly through the valve body (10).
6. Examine shoes (8) and (18) for contamination in balance pads and excessive scratching on shoe faces. Note the two shoes are not identical and must be installed in the proper position upon reassembly.
7. Remove the plug (13) with the stop assembly intact.
8. Remove the centering adjustment screw (23) with the spool assembly and stop assembly intact. Note: positive centering and control starting current are determined by the spring preload. Do not disassemble or change unless setting is incorrect.
9. Clean and examine all parts for breakage or evidence of abnormal wear.

**REWORK OF WEAR PARTS**

Description	Rework
Servo plate face	Fine stone to remove raised burrs & dings
Shear seal	Fine stone to remove raised burrs & dings. Note: grooves to supply balance pads must be present and adequate.
Control cover	Stone or lap inside face to remove raised burrs & dings.
Spool	Break sharp edges or dings.

**ASSEMBLY**

All parts are to be inspected and be free of material defects, dirt, scratches, or any foreign material.

All parts are to be cleaned with a suitable cleaning solvent and all cores and passages blown out with clean dry compressed air.

After cleaning and inspection, all parts are to be covered with a light film of oil and should be protected from dirt and excessive handling until assembled onto the unit. During assembly, lapped and ground surfaces should be kept lubricated and protected from nicks or surface damage.

1. Apply pipe sealant to the 1/8" pipe plug (12) and install in the cover plate. Torque to 100 lbs-in. (11.3 Nm).

2. Thread trimmer locknut (22) all the way onto trimmer screw (23). Slip back-up washer (21), small dia. first, onto trimmer screw and against locknut. Using a 3/4-16 hex nut with a 1.030" (26.2mm) dia. x .030/.035" (0.76/0.89mm) deep c'bore, crimp the washer onto the stop. Washer must be free to rotate slightly. Remove crimping nut.

See Figure 8A-1

3. Compress spring (4) solid in order to remove spring set. This may be safely accomplished using a 1/4" (6.35 mm) dia. bolt, nut and washers.  
 4. Assemble retaining ring (2), guide (3), spring (4) and guide (3) onto spool (1).  
 5. Tighten nut (7) till it just starts to load the spring, then tighten 2-5/6 additional turns.  
 6. Install locknut (5) onto spool and lock against nut (7) without changing adjustment.

See Figure 9A

7. Insert spool assembly (11), spring end first, into trimmer screw (23). Compress snap ring on the spool assembly until it snaps into internal groove inside trimmer screw. See that it is securely seated.  
 8. Thread spring stop locknut (24) all the way onto adjusting spring stop (25). Slip back-up washer (26), small diameter first, onto stop and against locknut. Using a 9/16-18 hex nut with a .810/.815" (20.6/20.7mm) dia. x .030-.035" (0.76-0.89mm) dp. c'bore, crimp washer onto stop. Washer must be free to rotate slightly. Remove the crimping nut.  
 9. Install O-ring (35) on plug (34) and insert into spring stop (25). Install O-ring (27) onto stop (25) and against washer (26).  
 10. Thread adjusting spring stop (25) into trimmer screw (23) until it just touches the spool assembly. Be sure spool assembly is against snap ring.  
 11. Determine the correct position of the spool assembly in the valve body. For 9A standard pump controls, and for 9A motor controls mounted on the "B" port side, the spool assembly is installed in the side of the control cap containing the 1/8" pipe plug (12). For controls used on P\*R pumps, and motor controls mounted on the "A" port side, the spool assembly is installed on the side opposite the 1/8" pipe plug (12).

MODEL	CONTROL LOCATION	SPOOL POS. REF. FIG. 9A
P*P, P*V, P*S	"A" OR "B"	OPPOSITE
P*R	"A" OR "B"	AS SHOWN
M*H, M*V	"A"	AS SHOWN
M*H, M*V	"B"	OPPOSITE

12. Place O-ring (14) on trimmer screw (23) and thread assembly into the cover plate, as noted above.  
 13. Install adjusting screw (15) in plug (13). Install O-ring (14) on plug. Thread adjusting screw in until it protrudes approximately 1/2" from top of plug (13). For motor controls, install two nuts (36) on the inner end.  
 14. Thread cover nut (16) with O-ring (31) onto adjusting screw.  
 15. Install plug (28) and O-ring (29) into cover nut (16).  
 16. Install this assembly in body on the opposite side from the spool assembly (11).  
 17. Install nut (36) on adjusting screw (6). Thread adjusting screw into stop (25).  
 18. Install roll pins (30) into drilled holes in surface of cover, being careful not to damage surface.  
 19. Install O-ring (7) in groove of shear seal (8).  
 20. Install shear seal with o-ring in large hole on the servo link, on the servo shaft side. Be certain that the shear seal is sitting with the flange flush against the servo link surface.

Note: The shear seal will fit in one position only, otherwise one side will be held up by the lip of the servo link. Shear seal (8) must be installed to face against the cover plate (10). This shear seal (8) differs from shear seal (18) in that the face surface is machined with two .094" (2.4mm) radius scallops.

21. Install thrust bearing (9) over servo shaft and seat against the servo link.  
 22. Slip washer (33) over the servo shaft and against the thrust bearing.  
 23. Using installation tool T-1, install O-ring (5) in the second groove from the end of the shaft (1). Warm glyd ring (20) to make it pliable, and install over O-ring (5).  
 24. Install the servo shaft assembly in the cover plate (10). Pin must engage slot in spool assembly (11).  
 25. Install retaining ring (4) into the groove of the servo shaft extending thru the cover plate.  
 26. Apply loctite® 271 on threads of screw (43), and on threads of shaft assembly (1). Assemble nut (44) on screw, insert screw into shaft assembly and turn in snugly. Hold screw and arm. Torque nut to 14 lb.-ft. (19 Nm).  
 27. Place two spring washers (17), nested with the bent sections matching each other, into the large hole in the servo link.

- 28. Place washer (32) against the spring washers.
- 29. Install O-ring (7) into groove in the remaining shear seal (18). Note: This shear seal does not contain the two .094" (2.4mm) radius scallops in the face. Place on top of washer, (32). Position shear seal to match the lip on the servo link.
- 30. Install four orifices (37) in two tapped holes in stroker block (39) closest to the valve opening. Insert one orifice, then another on top of the first. Torque to 70 lbs-in. (7.9 Nm).
- 31. Install proportional pressure valve(s) in block (39). Torque to 20 lb.-ft. (27 Nm). Cross-center pumps use two valves. One side of center pumps and motors use one valve. See chart for location of single valve:

CONT. LOCATION	VALVE LOCATION
PUMP, CW-A, CCW-B	VALVE "B", FIG. 9A
PUMP, CW-B, CCW-A	VALVE "A", FIG. 9A
MOTOR, B MTG.	VALVE "B", FIG. 9A
MOTOR, A MTG.	VALVE "A", FIG. 9A

- 32. For controls with single valve, install soc. setscrew (54) in the tapped hole furthest in from the unused opening. Torque to 70 in.-lb. (7.9 Nm). Install plug (53) and O-ring (55) in the unused opening. Torque to 20 lb.-ft. (27 Nm).
- 33. Install coil(s) (52) on proportional valve (38). **CAUTION! Torque to 20-25 in.-lb. (2.2-2.8 Nm) max.**
- 34. Install remaining parts.
- 35. If control is to be tested on unit, install stroker block assembly and control on pump control pad with O-rings (3, 31, and 45), gasket (19), washers (49) and screws (2). Torque to 30 Lb.-ft. (40.8 Nm).

**9A CONTROL TEST SETUP**

Remove plug over input shaft. Insert T handle 3/16" Allen wrench into opening. Connect proportional control driver to proportional valve. Connect pressure gage on SAE-4 port adjacent to proportional valve or valves. Rotate wrench handle to check for free play. Turn spring stop adjustment in or out till it just contacts the spring and there is no free play. Lock in place. Note: this adjustment is critical to accurate neutral adjustment!

**9A PUMP TEST**

- 1. Turn trimmer screw to place input shaft on the zero stroke position. Check for positive centering. Lock in place. For cross-center pumps, set max. volume stops so that servo shaft link touches stop pins when handle is stroked each side of center. For one side of center pumps, set max. stop so that servo shaft link touches the stop pin. Set min stop to prevent crossing over center. Lock stops in place.
- 2. Apply signal current to one proportional valve. Adjust current from minimum to maximum. Note the pressure and current value at which pump just starts to stroke, and at which the pump reaches full stroke These must be within the following values:

Coil	Cont. Pr. Min. Disp.	Ma. Min. Disp.	Cont. Pr. Max. Disp.	Ma Max. Disp.
12 Volt	75 ±15psi (5.17±1bar)	360 ± 60	250±25psi (17.2±1.7bar)	650 ± 110
24 Volt	75±15psi (5.17±1bar)	180 ± 30	250±25psi (17.2±1.7bar)	325 ± 55

- 3. If control pressure is off the same amount at start and end of stroke, the control may be disassembled and the spring (Figure 2) readjusted. One flat (1/6 turn) of adjustment will change the pressure by 4.6 psi (0.31 bar).
- 4. If the change in pressure from start to end of stroke is incorrect, the spring (Figure 2) is incorrect and must be replaced.
- 5. If pressures are correct but current is incorrect, then either the coil is incorrect or the proportional valve is bad.
- 6. With minimum signal, pump shall return to zero stroke within 200 psi. (13.8 bar) max.
- 7. For cross-center pumps, repeat test on opposite side of center.
- 8. Increase and decrease current between minimum and maximum several times. Pump stroke should follow control pressure smoothly and proportionally. Full to zero or zero to full stroke should be achieved in no more than two seconds. Adjust stroke up to approximately 50% stroke from zero stroke, then adjust down from full stroke to the same current value. The flow at the two settings shall not vary more than 25%.

**9A MOTOR TEST**

- 1. Turn trimmer screw to place input shaft on the full stroke position. Lock in position.
- 2. Rotate input handle to reduce motor displacement to minimum. **CAUTION!** do not exceed motor rated speed! Adjust minimum stop screw to set minimum displacement at 25% of full displacement. (4 times the rpm at maximum displacement.)

3. Lock screw in this position.
4. Apply signal current to proportional valve. Adjust current from minimum to maximum. Note the pressure and current value at which motor just starts to reduce stroke, and at which the motor reaches minimum stroke. These must be within the following values:

Coil	Cont. Pr. Max. Disp.	Ma. Min. Disp.	Cont. Pr. Min. Disp.	Ma Min. Disp.
12 Volt	75 ±15psi (5.17±1bar)	360 ± 60	205±25psi (14.1±1.7bar)	580 ± 100
24 Volt	75±15psi (5.17±1bar)	180 ± 30	205±25psi (14.1±1.7bar)	290 ± 50

5. If control pressure is off the same amount at start and end of stroke, the control may be disassembled and the spring (Figure 2) readjusted. One flat (1/6 turn) of adjustment will change the pressure by 4.6 psi (0.31 bar).
6. If the change in pressure from start to end of stroke is incorrect, the spring (Figure 2) is incorrect and must be replaced.
7. If pressures are correct but current is incorrect, then either the coil is incorrect or the proportional valve is bad.
8. With minimum signal, motor shall return to full stroke.
9. Increase and decrease current between minimum and maximum several times. Motor stroke should follow control pressure smoothly and proportionally. Full to min. or min. to full stroke should be achieved in no more than two seconds. Adjust stroke down to approximately 50% stroke from full stroke, then adjust up from 25% stroke to the same signal. The speed at the two settings shall vary no more than 25%.
10. When control has satisfactorily passed test, remove stop assembly, set and lock the two nuts on the inside to prevent adjustment below 25% stroke. Re-install stop.

**PARTS LIST**

Figure 9A Electric stroker

Feature → Option →			00 P*P, P*S Pump	00 6R,7R,8R Pump	01 P*P,P*S Pump	00 P*V Pump	0* M*H, M*V Motor
Assembly No. →			S23-12667	S23-12940	S23-12957	S23-12734 S23-12733	S23-15050 S23-15051
ITEM	DESCRIPTION	PT. NO.	QTY.	QTY.	QTY.	QTY.	QTY.
1	Servo shaft	S23-12267	1	1	1	1	1
2	HHCS 3/8-16 X 3.25"	306-40184	4	4	4	4	4
3	O-ring, 70- S-5 ARP 013	675 00013	9	9	9	9	9
4	Ring, Truarc #5144-50	356-65070	1	1	1	1	1
5	O-ring, 70 S-5 ARP 012	675-00012	5	5	5	5	5
6	HHCS, 5/16-24 X 1"	307-13160	1	1	1	1	-
	Setscrew, 5/16-24 X 1.25"	312-13180	-	-	-	-	1
7	O-ring, 70 S-5 ARP 017	675-00017	2	2	2	2	2
8	Shear Seal	033-71371	1	1	1	1	1
9	Bearing	230-82141	1	1	1	1	1
10	Cover-9A	033-91220	1	1	1	1	1
11	Spool Assy (Fig. 8A-1)	S23-12956	1	1	1	1	1
12	Flush plug 1/8"	431-90204	1	1	1	1	1
13	SAE plug	033-91027	1	1	1	1	1
14	O-ring, 90 S-5 ARP 908	695-00908	3	3	3	3	3
15	Soc. setscrew, 5/16-24 X 2"	312-35062	1	1	1	1	-
	Setscrew, 5/16-24 X 2.50"	312-35063	-	-	-	-	1
16	Nut	033-91033	1	1	1	1	1
17	Finger Spring	350-10067	2	2	2	2	2
18	Shear seal	033-70525	1	1	1	1	1
19	Gasket	033-91058	1	1	1	1	1
20	Glyd ring	679-00004	1	1	1	1	1
21	Washer	350-10139	1	1	1	1	1
22	Nut	033-91115	1	1	1	1	1
23	Center trimmer	033-91028	1	1	1	1	1
24	Locknut	492-15353	1	1	1	1	1
25	Stop	033-91026	1	1	1	1	1
26	Washer	350-10126	1	1	1	1	1
27	O-ring, 90 S-5 ARP 906	695-00906	1	1	1	1	1
28	Plug, Parker 2P5N-S	488-35029	1	1	1	1	1
29	O-ring, 90 S-5 ARP 902	695-00902	1	1	1	1	1
30	Rollpin 3/16 X .75"	325-12120	2	2	2	2	2
31	O-ring, 70 S-5 ARP 014	675-00014	2	2	2	2	2
32	Washer	350-10064	1	1	1	1	1
33	Washer	350-10141	1	1	1	1	1
34	Piston	033-91099	1	1	1	1	1
35	O-ring, 70 S-5 ARP 010	675-00010	1	1	1	1	1
36	Nut, 5/16-24	335-13100	1	1	1	1	3
37	Orifice, .025"	033-91225	4	4	4	4	4
38	Valve- proportional	517-00095	2	2	2	1	1
38-a	O-ring, 70 S-5 ARP 015	675-00015	2	2	2	1	1
38-b	O-ring, 90 S-5 ARP 016	695-00016	2	2	2	1	1

**PARTS LIST**

Figure 9A Electric stroker

		Feature → Option →	00 P*P, P*S Pump	00 6R,7R,8R Pump	01 P*P,P*S Pump	00 P*V Pump	0* M*H, M*V Motor
		Assembly No. →	S23-12667	S23-12940	S23-12957	S23-12734 S23-12733	S23-15050 S23-15051
ITEM	DESCRIPTION	PT. NO.	QTY.	QTY.	QTY.	QTY.	QTY.
38-c	O-ring, 90 S-5 ARP 116	695-00116	2	2	2	1	1
39	Stroker Block	033-54991	1	1	1	1	1
40	Plug, SAE-4	488-35061	2	2	2	2	2
41	O-ring, 90 S-5 ARP 904	695-00904	2	2	2	2	2
42	Plug, Parker 8HP N-S	488-35018	1	1	1	1	1
43	SHCS, 1/4-20 X 2.25"	358-12100	1	1	1	1	1
44	Nut, 1/4-20	333-12001	1	1	1	1	1
45	O-ring, 70 S-5 ARP 121	675-00121	1	1	1	1	1
46	Connector	167-01008	2	2	2	1	1
47	Guard	033-54994	1	1	1	1	1
48	SHCS, 1/4-20 X 2.25"	306-12260	2	2	2	2	2
49	Washer	350-10144	4	4	4	4	4
50	Plate	030-55002	1	-	-	-	-
	Plate	030-55003	-	1	1	1	1
51	Drive screw	320-10203	2	2	2	2	2
52	Coil, 24 VDC.	517-00096	2	2	-	1	1
	Coil, 12 VDC	517-00097	-	-	2	-	-
53	Plug, Parker 10 P50N-S	488-35016	-	-	-	1	1
54	SHCS, 10-32 X .19"	312-09030	-	-	-	1	1
55	O-ring, 90 S-5 ARP 910	695-00910	-	-	-	1	1
56	Washer	345-10016	2	2	2	2	2



**9C ELECTRIC STROKER WITH BRAKE AND BYPASS VALVE**

S23-12925 - A/B - 00 Pump (Cross ctr. 24V)

**DESCRIPTION**

The 9C is basically an 8C package with the addition of two electric proportional pressure control valves mounted in a manifold block, thus proportionally controlling pump stroke by means of an electrical signal, while incorporating a brake and bypass valve function in the package. The Jupiter 900 Driver Card has been developed to accompany the 9C control with 24V coil. Refer to 8C and 8A for brake and stroker description.

**DISASSEMBLY**

See Figure 9C

1. Disconnect connector (58) from coil (64).
2. Remove proportional valves from block (53). Do not attempt disassembly of the valve, other than replacement of the coil, (64) and external O-rings, (53-a), (53-b) and (53-c).
3. Remove screws (2) from control. Remove proportional valve block (54) from control. Remove control from pump.
4. Examine servo plate for excessive scratching on surface. Note if orifices in stem are open. If servo plate is scratched or orifices appear to be plugged, remove plate and servo stem by removing two soc. setscrews from plate, then alternately loosening the two button hd. screws under the setscrews.
5. Remove retaining ring (4) and press the shaft assembly through the valve body.
6. Examine shoes (8) and (18) for contamination in balance pads and excessive scratching on shoe faces. Note the two shoes are not identical and must be installed in the proper position upon reassembly.
7. Remove the brake trimmer stop assembly (13) intact.
8. Remove the center trimmer screw (23) with the spool assembly and stop assembly intact. Note: signal pressure setting is determined by the spring preload. Do not disassemble or change unless setting is incorrect.
9. Remove tubing assembly (74). Remove bypass valve body (42) with fitting (44) and piston (45). Remove elbow (73) with orifice (37) and fitting (38). Remove spools (31) and (39).
10. Remove shoe (50), and spring (49).
11. Examine orifices (16) and (29) in body for contamination. Examine passages in body for free flow.
12. Clean and examine all parts for breakage or evidence of abnormal wear.

**REWORK OF WEAR PARTS**

Description	Rework
Servo plate face	Fine stone to remove raised burrs & dings
Shear seal	Fine stone to remove raised burrs & dings. Note: grooves to supply balance pads must be present and adequate.
Control cover	Stone or lap inside face to remove raised burrs & dings.
Spool	Break sharp edges or dings.
Shoe	Stone to remove raised burrs or dings.

**ASSEMBLY**

All parts are to be inspected and be free of material defects, dirt, scratches, or any foreign material.  
 All parts are to be cleaned with a suitable cleaning solvent and all cores and passages blown out with clean dry compressed air.  
 After cleaning and inspection, all parts are to be covered with a light film of oil and should be protected from dirt and excessive handling until assembled onto the unit.  
 During assembly, lapped and ground surfaces should be kept lubricated and protected from nicks or surface damage.

See Figure 9C

1. Install .031" orifices (29), checking to see that they clear the bore. Install the .018" orifice (16) in body.
2. Apply pipe sealant and install 1/16 pipe plugs (28) in body as shown. Torque to 25 lbs-in.. (2.8 Nm)
3. Apply pipe sealant to the 1/8" pipe plugs (12) and install in the cover plate. Torque to 100 lbs-in.. (11.3 Nm)
4. Thread trimmer locknut (22) all the way onto center trimmer screw (23). Slip back-up washer (21), small dia. first, onto trimmer screw and against locknut. Using a 3/4-16 hex nut, with a 1.030" (26.2mm) dia. x .030/.035" (0.76/0.89mm) deep c'bore, crimp the washer onto the stop. Washer must be free to rotate slightly. Remove crimping nut.

See Figure 8C-1

5. Compress spring (4) solid in order to remove set. This may be safely accomplished using a 1/4" (6.35 mm) dia. bolt, nut and washers.
6. Assemble retaining ring (2), guide (3), spring (4) and guide (9) onto spool (1).
7. Tighten nut (6) till it just starts to load the spring, then tighten 2 5/6 additional turns
8. Install locknut (5) onto spool and lock against nut (6) without changing adjustment.
9. Install spool (7) onto other end of spool assembly (1). Install nuts (8) and tighten till spool has from .001 to .003" (.025 to .076 mm) clearance. (Barely free to rotate without binding). Lock nuts together and re-check spool fit.

See Figure 9C

10. Insert spool assembly (11), spring end first, into center trimmer screw (23). Compress snap ring on the spool assembly until it snaps into internal groove inside trimmer screw. See that it is securely seated.
11. Thread spring stop locknut (24) all the way onto adjusting spring stop (25). Slip back-up washer (26), small diameter first, onto stop and against locknut. Using a 9/16-18 hex nut with a .810/.815" (20.6-20.7mm) dia. x .030-.035" (0.76-0.89mm) dp. c'bore, crimp washer onto stop. Washer must be free to rotate slightly. Remove the crimping nut.
12. Install O-ring (35) on plug (34) and insert into spring stop (25). Install O-ring (27) onto stop (25) and against washer (26).
13. Thread spring adjustment stop (25) into trimmer screw (23) until it just touches the spool assembly. Be sure spool assembly is against snap ring.
14. Place O-ring (14) on trimmer screw (23) and thread assembly into the larger cross-bore in the cover plate. Install from the end which contains the 1/16" pipe plug.
15. Install nut (36) on adjusting screw (6). Thread adjusting screw into stop (25).

See Figure 8C-2

16. Thread locknut (8) all the way onto guide (1). Slip back-up washer (7), small dia. first, onto guide and against locknut. Using a 3/4-16 hex nut, with a 1.030" (26.2mm) dia. x .030/.035" (0.76/0.89mm) deep c'bore, crimp the washer onto the stop. Washer must be free to rotate slightly. Remove crimping nut.
17. Install stop (2) into guide. Install O-ring (9) on nut (3) and install over stop (2). Install O-ring (10) over plug (11). Install plug in nut (3).
18. Install O-rings (4,5, and 6) on guide (1). Lubricate O-rings and carefully insert guide into bore and over spool on opposite side from the trimmer screw.

See Figure 9C

19. Install spools (31) and (39) into the other cross-bore in the cover (10). The slotted end of spool (31) should be to the outside.
20. Install O-ring (27) on plug (38). Install spring (37) in plug and install plug in cover as shown.
21. Install O-rings (43) on fitting (44). Install piston (45) in bore of body (42). Install O-ring (72) on plug (71) and install plug in body (42). Install seals (70) on body (42). Install fitting (44) on body and install assembly in cover (10).
22. Install rollpins (30) in cover, being careful not to damage the cover surface.
23. Install O-rings (46) and (47) on vent post (48). Install vent post in cover.
24. Install spring (49) and shoe (50) over vent post.
25. Install O-ring (7) in groove of shear seal (8).
26. Install shear seal with o-ring in large hole on the servo link, on the servo shaft side. Be certain that the shear seal is sitting with the flange flush against the servo link surface.

Note: The shear seal will fit in one position only, otherwise one side will be held up by the lip of the servo link. Shear seal (8) must be installed to face against the cover plate (10). This shear seal (8) differs from shear seal (18) in that the face surface is machined with two .094" (2.4mm) radius scallops.

27. Install thrust bearing (9) over servo shaft and seat against the servo link.
28. Slip washer (33) over the servo shaft and against the thrust bearing.
29. Using installation tool T-1, install O-ring (5) in the second groove from the end of the shaft (1). Warm glyd ring (20) to make it pliable, and install over O-ring (5).
30. Install the servo shaft assembly in the cover plate (10). Pin must engage slot in spool assembly (11).
31. Install retaining ring (4) into the groove of the servo shaft extending thru the cover plate.
32. Apply Loctite 271 on threads of screw (55), and on threads of shaft assembly (1). Assemble nut (56) on screw, insert screw into shaft assembly and turn in snugly. Torque nut to 14 lb.-ft. (19 Nm).
33. Place two spring washers (17), nested with the bent sections matching each other, into the large hole in the servo link.
34. Place washer (32) against the spring washers.
35. Install O-ring (7) into groove in the remaining shear seal (18). Note: This shear seal does not contain the two .094 radius scallops in the face. Place on top of washer, (32). Position shear seal to match the lip on the servo link.

- 36. Install four orifices (52), two each in two tapped holes in stroker block (54) closest to the proportional valve.
- 37. Install proportional pressure valves (53) in block (54). Torque to 20 lb.-ft. (27 Nm).
- 38. Install coils (64) on proportional valves (53). **CAUTION! Torque to 20-25 in.-lb. (2.2-2.8 Nm) MAX.**
- 39. Install remaining parts.
- 40. If control is to be tested on pump, install on pump control pad with O-rings (3), (5) and (57), gasket (19), washers (61), and screws (2). Torque to 30 lb. ft. (40.8 Nm). Install bypass check valves fittings, and lines.

**TEST**

Remove plug over input shaft. Insert T handle 3/16" (4.76mm) hex wrench into opening  
 Connect proportional control driver to proportional valves electrical connection.  
 Install a needle valve on the bypass valve exhaust port, connected to tank. Close the valve.

Install a 500 psi (35 Bar) gage in the brake port.  
 Rotate the T handle to check for free play. Turn spring adjustment in or out till there is no free play. Lock in place. **Note: this adjustment is critical to accurate neutral adjustment!**

- 1. Start prime mover and adjust system relief valve for 5000 psi (345 bar).
- 2. Turn centering trimmer screw to place input shaft on the zero stroke position. Stroke pump to full and release, on both sides of center. Pump shall return to zero stroke within 200 psi (13.8 bar) max.
- 3. With pump on zero stroke, turn brake trimmer screw CW and CCW while observing gage on brake port. Note the positions where the gage reading changes from case pressure to servo pressure to case pressure. Set and lock the adjustment midway between these two positions.
- 4. Set max. volume stops so that servo shaft link touches stop pins when T handle is rotated each side of center. Caution! Do not exceed 100 in. lb. (11.3 Nm) torque. Lock in place.
- 5. Apply signal current to one proportional valve. Adjust current from minimum to maximum. Note the pressure and current value at which pump just starts to stroke, and at which the pump reaches full stroke These must be within the following values:

Coil	Cont. Pr. Min. Disp.	Ma. Min. Disp.	Cont. Pr. Max. Disp.	Ma Max. Disp.
12 Volt	75 ±15psi (5.17±1bar)	360 ± 60	250±25psi (17.2±1.7bar)	650 ± 110
24 Volt	75±15psi (5.17±1bar)	180 ± 30	250±25psi (17.2±1.7bar)	325 ± 55

- 6. If control pressure is off the same amount at start and end of stroke, the control may be disassembled and the spring (Figure 2) readjusted. One flat (1/6 turn) of adjustment will change the pressure by 4.6 psi (0.31 bar).
- 7. If the change in pressure from start to end of stroke is incorrect, the spring (Figure 2) is incorrect and must be replaced.
- 8. If pressures are correct but current is incorrect, then either the coil is incorrect or the proportional valve is bad.
- 9. With minimum signal, pump shall return to zero stroke within 200 psi. (13.8 bar) max.
- 10. Repeat test on opposite side of center.
- 11. Increase and decrease current between minimum and maximum several times. Pump stroke should follow control pressure smoothly and proportionally. Full to zero or zero to full stroke should be achieved in no more than two seconds. Adjust stroke up to approximately 50% stroke from zero stroke, then adjust down from full stroke to the same current value. The flow at the two settings shall not vary more than 25%.
- 12. Stroke pump control one side of center. The gage on the brake port should start to indicate servo pressure when the system pressure is between 2000 and 4500 psi (138 and 310 bar), with an increasing signal, and must return to case pressure before system pressure drops to 2000 psi (138 bar), on decreasing signal. Repeat by stroking control other side of center. Record both pressures for each side of center.
- 13. Open the needle valve on the neutral bypass port. Measure and record leakage from this port with the pump on center at minimum psi, and with the pump off center, at 5000 psi

**Maximum leakage with control on center:**

2.0 gpm (7.6 l/m)

**Minimum leakage with control on center:**

1.0 gpm (3.8 l/m)

**Maximum leakage with control off center:**35 cu. in/min or .15 gpm (574 cm<sup>3</sup>/min. or 0.57 l/m)

14. Stroke pump above and below center. Control should operate smoothly. Brake pressure should drop to case pressure each time control is on center, and it should indicate servo pressure as soon as input shaft is rotated CW or CCW from center, per step 12 above.

15. Remove needle valve from bypass exhaust port and install exhaust line.

16. Release control when pump is off center. Pump should return to center. Repeat several times in each direction and at different pressures from 200 to 5000 psi (13.8 to 345 bar). Observe for leaks and proper operation.

**PARTS LIST**

Figure 9C Electric stroker with  
brake and bypass valve

S23-12925 (Feature 00)

ITEM	DESCRIPTION	PT. NO.	QTY.
1	Servo shaft	S23-12267	1
2	HHCS, 3/8-24 X 3.25	306-40184	4
3	O-ring, 70 S-5 ARP 013	675-00013	8
4	Ring, Truarc 5144-50	356-65070	1
5	O-ring, 70 S-5 ARP 012	675-00012	5
6	Screw, HHC 5/16-24 X 1"	307-13160	1
7	O-ring, 70 S-5 ARP 017	675-00017	2
8	Shear seal	033-71371	1
9	Bearing	230-82141	1
10	Cover	033-91470	1
11	Spool Assy (Fig. 8C-1)	S23-12935	1
12	Flush plug 1/8"	431-90204	4
13	Brake trimmer (Fig. 8C-2)	S23-12921	1
14	O-ring, 90 S-5 ARP 908	695-00908	2
15	O-ring, 70 S-5 ARP 015	675-00015	1
16	Orifice, .018"	035-19092	1
17	Finger spring	350-10067	2
18	Shear seal	033-70525	1
19	Gasket	033-91058	1
20	Glyd ring	679-00004	1
21	Washer	350-10139	1
22	Nut	033-91115	1
23	Center trimmer	033-91028	1
24	Locknut	492-15353	1
25	Stop	033-91026	1
26	Washer	350-10126	1
27	O-ring, 90 S-5 ARP 906	695-00906	2
28	Plug, 1/16" flush	431-90104	3
29	Orifice	033-91757	2
30	Rollpin, 3/16 X .75"	325-12120	2
31	Spool	033-70999	1
32	Washer	350-10064	1
33	Washer	350-10141	1
34	Piston	033-91099	1
35	O-ring, 70 S-5 ARP 010	675-00010	1
36	Nut, 5/16-24	335-13100	1
37	Orifice, .0135"	033-91758	1
38	Fitting	492-15375	1
39	Spool	033-91685	1
40	Spring	033-70992	1
41	Dowel pin, 1/16 X .50"	324-30026	1
42	Body	033-91698	1
43	O-ring, 90 S-5 ARP 016	695-00016	2
44	Fitting	033-91700	1
45	Piston	033-91699	1
46	O-ring, 90 S-5 ARP 902	695-00902	1

**PARTS LIST**

Figure 9C Electric stroker with  
brake and bypass valve

S23-12925 (Feature 00)

ITEM	DESCRIPTION	PT. NO.	QTY.
47	O-ring, 70 S-5 ARP 006	675-00006	1
48	Vent post	033-70995	1
49	Spring	225-92044	1
50	Shoe	033-70996	1
51	O-ring, 70 S-5 ARP 014	675-00014	2
52	Orifice, .025"	033-91225	1
53	Valve-proportional	517-00085	1
53-a	O-ring, 70 S-5 ARP 015	675-00015	1
53-b	O-ring, 90 S-5 ARP 016	695-00016	1
53-c	O-ring, 90 S-5 ARP 116	695-00116	1
54	Stroker block	033-54991	1
55	SHCS, 1/4-20 X .625"	358-12100	1
56	Nut, 1/4-20	333-12001	1
57	O-ring, 70 S-5 ARP 121	675-00121	1
58	Connector	167-01008	2
59	Guard	033-54994	1
60	Screw, 1/4-20 X 2.25"	306-12260	2
61	Washer	350-10144	4
62	Plate	030-55003	1
63	Drive screw	320-10203	2
64	Coil - 24 VDC	517-00086	2
65	Plug, Parker 8HP N-S	488-35018	1
66	Washer	345-10016	2
67	Plug, SAE-4	488-35061	2
68	O-ring, 90 S-5 ARP 904	695 00904	2
69	Seat, spring	033-91686	1
70	Tetraseal	695-10013	2
71	Plug, SAE-3	488-35049	1
72	O-ring, 90 S-5 ARP 903	695-00903	1
73	Elbow	033-91702	1
74	Tube assembly	S23-15202	1
75	Tee, st. thd run, SAE-6	497-15008	1
76	Reducer	492-15376	1
77	Nut	492-10012	1

PHA4810  
2010-03-11  
21:05:35  
Should be 5170085  
OK

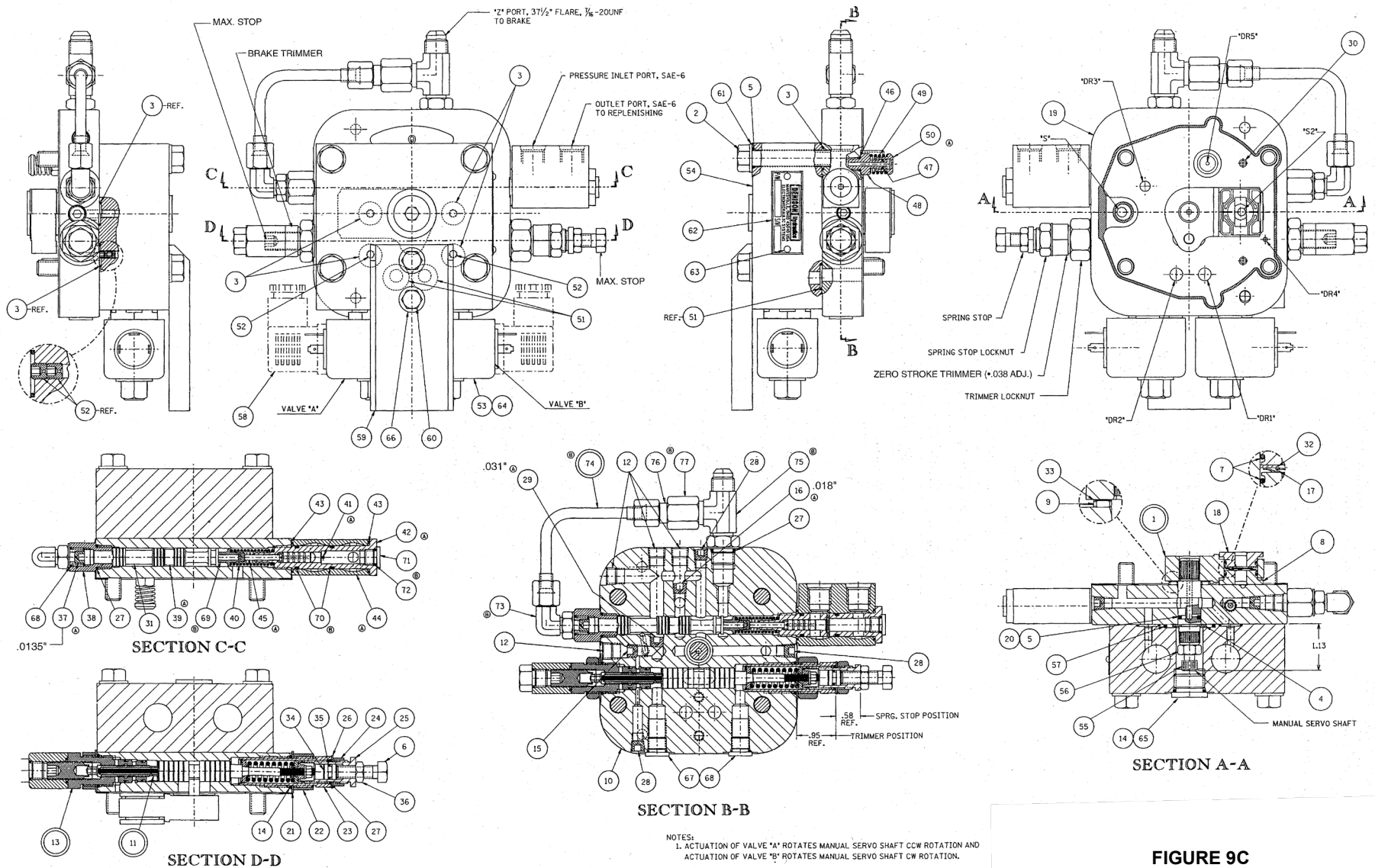

**FIGURE 9C**  
**ELECTRIC STROKER WITH BRAKE AND**  
**BYPASS VALVE**

**CODE \*\*4 - TORQUE LIMITER  
OPTION**

S23-12299  
*Both sides of center*

S23-12298  
*“A” Mounting CCW Rotation  
“B” Mounting CW Rotation*

S23-12300  
*“A Mounting CW Rotation  
“B Mounting CCW Rotation*

**DESCRIPTION**

The torque limiter override hydraulically limits the maximum shaft torque imposed by the pump load at all speeds. This operation is in addition to the pressure compensator override. It limits the compensating pressure in proportion to displacement so that the product of pressure and displacement, P x Q, does not exceed the set value. A fixed flow of servo oil is applied to the end of a spool. A stroke controlled orifice meters this flow to the pump case, establishing a pressure on the end of the spool. System pressure is applied to the end of a pin in contact with the opposite end of the spool. A port opens to allow system pressure into the control chamber to de-stroke the pump whenever the force on the 1/8" (3.18mm) dia. pin overcomes the force on the end of the 7/16" (11.1mm) dia. spool. The area of the orifice is varied by the pump stroke in such a manner that the pressure developed will be inversely proportional to stroke. For example, at 1/2 stroke, the pressure will be twice the pressure at full stroke. At 1/3 stroke, the pressure will be 3 times the pressure at full stroke. An adjustable flow control establishes the pilot flow, and thereby the controlled torque value. An adjustable restriction in series with the stroke controlled orifice permits adjustment of linearity. For limiting on both system ports, two independent torque limiters are required. The control contains both in the same body. The one side of center control contains one torque limiter, to limit the "A" system port.

**DISASSEMBLY**  
See S23-12299

1. Disconnect tubing lines from pump. Remove screws (2). Remove control from pump.
2. Remove indicator (39). Remove retaining ring (3) and press the shaft assembly through the valve body.
3. Examine shoes (7) and (41) for contamination in balance pads or excessive scratching on faces. Note: the two shoes are not identical and must be installed in the proper position on reassembly.
4. Remove the bodies (27) with attached parts. Remove the spools (25). Examine spools and bores for free motion, wear or contamination.
5. Remove cover nuts (36) and screws (35).
6. Remove plug (34), spring (32), retainer (31) and filter assembly (28). Examine filter assembly carefully for contamination.
7. Remove cover nuts (38) and screws (44).
8. Remove plugs (21) springs (19) and spools (18).
9. Solvent wash and check all passageways for free flow.

**REWORK OF WEAR PARTS**

Description	Rework
Servo plate face	Fine stone to remove raised burrs & dings
Shear seal	Fine stone to remove raised burrs & dings. Note: grooves to supply balance pads must be present and adequate.
Control cover dings.	Stone or lap inside face to remove raised burrs &
Spool	Break sharp edges or dings.

Preparation for assembly  
All parts are to be inspected and be free of material defects, dirt, scratches or any foreign material.  
All parts are to be cleaned with a suitable cleaning solvent and all cores and passages blown out with clean dry compressed air.  
After cleaning and inspection, all parts are to be covered with a light film of oil and should be protected from dirt and excessive handling until assembled onto the unit. During assembly, lapped and ground surfaces should be kept lubricated and protected from nicks or surface damage.

**ASSEMBLY**

See S23-12299

1. Apply loctite pipe sealant and install plugs (12) in body. Torque to 25 in.-lb. (2.8 Nm)
2. Press dowel pin (9) into the .125" (3.18mm) dia. hole directly over the centerline of the 7/16" (11.1mm) diameter spool bore of the cover plate (10). Press to .125" (3.18mm) below the surface, being careful not to mar the surface.
3. Press spring pin (11) into the stepped bore from the end of the body. The end of the spring pin must be positioned 1.00" (25.4mm) below the spotface.

*Cross center control S23-12299*

4. Install the two spools (18) into the 7/16" (11.1 mm) bore that has the spring pin passing through it. The end of the spools having the drilled hole should extend towards the outer edge of the cover plate. Install the two springs (19) into the installed spools (18). Install the two O-rings (20) and the two plugs (21).
5. In the remaining bore, install one spacer (22) against the dowel pin (9). The tetraseal groove and tapped hole should be facing towards the outer end of the bore. Place the tetraseal (23) into the bore and slide it past the cross drilled hole and up against the spacer (22). Drop the ring (24) down against the tetraseal (23). Using a squared end rod slightly smaller than the bore, push the tetraseal onto the shoulder groove of the spacer (22). Fill the bore with hydraulic fluid and install spool (25), displacing the hydraulic fluid, to insure an air free cavity under the spool.
6. Press dowel pin (13) into body (27), using care not to damage the surface. Center the pin in the body. If the pin protrudes, carefully grind flush to clear fitting (26).
7. Slip pin (14) into body (27).
8. Install O-rings (29) in fitting (26) and insert body (27). Thread into bore on top of spool (25), with open port of fitting (26) toward center of control. Torque to 15 lbs.-ft. (20.3 Nm).
9. Repeat steps 5 thru 8 on other end of bore.

*One side center controls  
See S23-12298, S23-12300*

10. Install spool (18) and spring (19) on one side only per chart below.
11. Complete steps 5 thru 8 on one side only per chart below. Install spool (18) on opposite side of this bore, then install plug (21) with O-ring (20).

Pump Rotation & Input Control mtg.*	Location of T. L. parts
CW-B, CCW-A	See S23-12298
CW-A, CCW-B	See S23-12300

\*Note: Torque limiter is mounted on the opposite side from the input control.

**ALL CONTROLS**

12. Install strainer ass'y (28) piloted over the spring pin (11). Push the O-ring (30) down against the assembled filter and install the retainer (31). The tapered end must rest against the O-ring. Install the spring (32) into the tapered socket of the retainer (31) and install the O-ring (33) and the plug (34).
13. Install the two #10-32 socket setscrews (35). Bottom these screws out lightly, then back out approximately two turns. Install nuts (36), O-ring (37), plug (15) and O-rings (16).
14. Install the 1/4-20 socket set screws (44). Bottom these screws out lightly, then back out approximately 1-3/4 turns. Install nuts (38) with O-ring (30), plugs (15) and O-ring (16).
15. Install O-ring in groove of shear seal (7). Install shear seal with O-ring in the large hole on the servo link, on the servo shaft side. Be certain that the shear seal is sitting with the flange flush against the servo link surface.

Note: The shear seal will fit in one position only. Otherwise one side will be held up by the lip of the servo link. Shear seal (7) must be installed to face against the cover plate (10). This shear seal contains two variable width slots. The width and depth are critical to accuracy of control.

16. Install needle bearing (8) over servo shaft and seat against the servo link. Install thrust washer (45) over needle bearing.
17. Install O-ring (4) in the second groove from the end of the shaft, using installation tool T-1.
18. Install the servo shaft assembly in the cover plate. (10).
19. Install retaining ring (3) into the groove of the servo shaft extending through the cover plate.
20. Place two spring washers (40), nested with the bent sections matching each other, into the large hole in the servo link.
21. Place washer (43) against the spring washers.
22. Install O-ring into groove in the remaining shear seal (41). Note: This shear seal does not contain the two tapered grooves in the face. Place on top of washer (43). Position shear seal to match the lip on the servo link.
23. Place servo link against a solid object and press indicator (39) on the servo shaft end. Align the pointer line on the indicator with the scribed line across the shaft.

When the pointer is towards the letter "O", the link should be centered over the 1/8" (3.18mm) dowel pin. Install screw (17).

24. To mount on pump, set the gap between the spacers which drive the servo arm to .010" (0.254 mm) clearance with the arm. Slip servo arm between the two spacers and align control with housing dowels. Install control on pump with screws (2), new Nyltite washers (5), and gasket (42). Torque screws to 30 ft.-lb. (40.8 Nm). Install fittings and tube lines to torque limiter control.

**TEST**

1. Use formula below to calculate (a) the flow with the pump at the maximum pressure, and (b) the pressure with the pump at maximum stroke, for the desired power setting at the test stand R.P.M.

$$HP = P \times Q / (\text{Eff.} \times 1714)$$

Where P = Pressure in PSI  
Q = flow in GPM

Example:  $50 = 5000 \times Q / (.85 \times 1714)$  (a) Q=14.6 GPM  
 $50 = P \times 46.8 / (.85 \times 1714)$  (b) P=1557 PSI

for 50 HP with maximum pressure 5000 PSI, maximum flow 46.8 GPM (Series 6 at 1800 RPM) and efficiency of 85% at these conditions.

or  $KW = P \times Q / (\text{Eff.} \times 600)$

where P = pressure in Bar  
Q = flow in l/min.

Example:  $50 = 345 \times Q / (.85 \times 600)$  (a) Q=73.9 l/min.  
 $50 = P \times 177 / (.85 \times 600)$  (b) P=144 bar

for 50 KW with maximum pressure 345 bar, maximum flow 177 l/min. (Series 6 at 1800 RPM) and 85% efficiency at these conditions.

2. Set the test stand at the maximum pressure for the system. Set the pump compensator above this value. Place the pump on stroke. If the pump does not meet the calculated flow (a) for this pressure, back the torque adjusting screw out, till the pump provides this flow. If the pump exceeds this flow, turn the torque adjusting screw in, till the control limits at this flow.
3. Reduce the test stand pressure setting to the calculated value (b) for the pump at full flow. Set the pump control to full stroke. If the pump fails to reach full flow, turn the linearity screw in till the pump hits full flow. If the pump reaches full flow, back the linearity screw out till the pump just commences to reduce stroke.
4. If linearity adjustment was required, repeat steps.

Note: Electric motor current may be used instead of the calculated values of pressure and flow. In step 2, adjust the torque adjusting screw to obtain the motor amperes at maximum pressure. In step 3, adjust the linearity screw to obtain the same motor amperes at full flow.

Chart for location of torque adjustment screws  
(See S23-12298, S23-12299, S23-12300)

*Servo Rot.	Torque & Linearity Adj.
CW	"E"
CCW	"F"

\*Note: Torque limiter indicator rotation is opposite to servo rotation.

**PARTS LIST**

*For torque limiter*

*S23-12299*

*Control both sides of center, A & B mounting*

*S23-12298*

*Control 1 Side, CW rotation B mounting, CCW rotation A mounting*

*S23-12300*

*Control 1 Side, CW rotation A mounting, CCW rotation B mounting*

ITEM	DESCRIPTION	PART NO	1 Side Ctr. QTY	2 Sides Ctr. QTY
1	Servo shaft assembly	S13-48437	1	1
2	Screw, hwhd. 3/8-16 x 1 1/4	353-25018	4	4
3	Retaining ring, #5144-50	356-65070	1	1
4	O-ring, 70 S-1 ARP 013	671-00013	1	1
5	Washer, Nyltite #37	631-45007	4	4
6	O-ring, 70 S-1 ARP 017	671-00017	2	2
7	Torque limiter shoe	033-71204	1	1
8	Needle bearing	230-82141	1	1
9	Dowel pin, 1/8 x 5/8	324-20810	1	1
10	Cover	033-92187	1	1
11	Spring pin, 1/4 x 7/8	325-16140	1	1
12	1/16 pipe plug	431-90100	3	3
13	Dowel pin, 1/8 x 5/8	324-20810	1	2
14	Pin	230-82190	1	2
15	O-ring, 90 S-1 ARP 902	691-00902	4	4
16	Plug, 2P5N-S	488-35029	4	4
17	Soc. setscrew 10-32	312-09032	1	1
18	Spool	033-71198	2	2
19	Compression spring	225-92049	1	2
20	O-ring, 90 S-1ARP 906	691-00906	3	2
21	Plug, 6HP5ON-S	488-35041	3	2
22	Retaining ring	033-71203	1	2
23	Tetraseal,90 S-1 ARP 011	691-10011	1	2
24	Spacer	033-71201	1	2
25	Spool	033-54473	1	2
26	Fitting	033-70998	1	2
27	Body	033-54472	1	2
28	Filter	S13-46764	1	1
29	O-ring, 90 S-1 ARP 016	691-00016	2	4
30	O-ring, 70 S-1 ARP 011	671-00011	3	3
31	Retainer	033-71196	1	1
32	Compression spring	225-92048	1	1
33	O-ring, 90 S-1 ARP 905	691-00905	1	1
34	Plug	033-92186	1	1
35	Soc. Setscrew	311-12160	2	2
36	Cover nut	033-92191	2	2
37	O-ring, 70 S-1 ARP 011	671-00011	2	2
38	Cover nut, 1/4-20	033-91039	2	2
39	Indicator	033-70624	1	1
40	Finger spring washer	350-10067	2	2
41	Shear seal	033-70525	1	1
42	Control cover gasket	033-91058	1	1
43	Thrust washer	350-10064	1	1
44	Soc. setscrew, 1/4-20 x 1 3/4	311-12220	2	2
45	Washer	350-10141	1	1

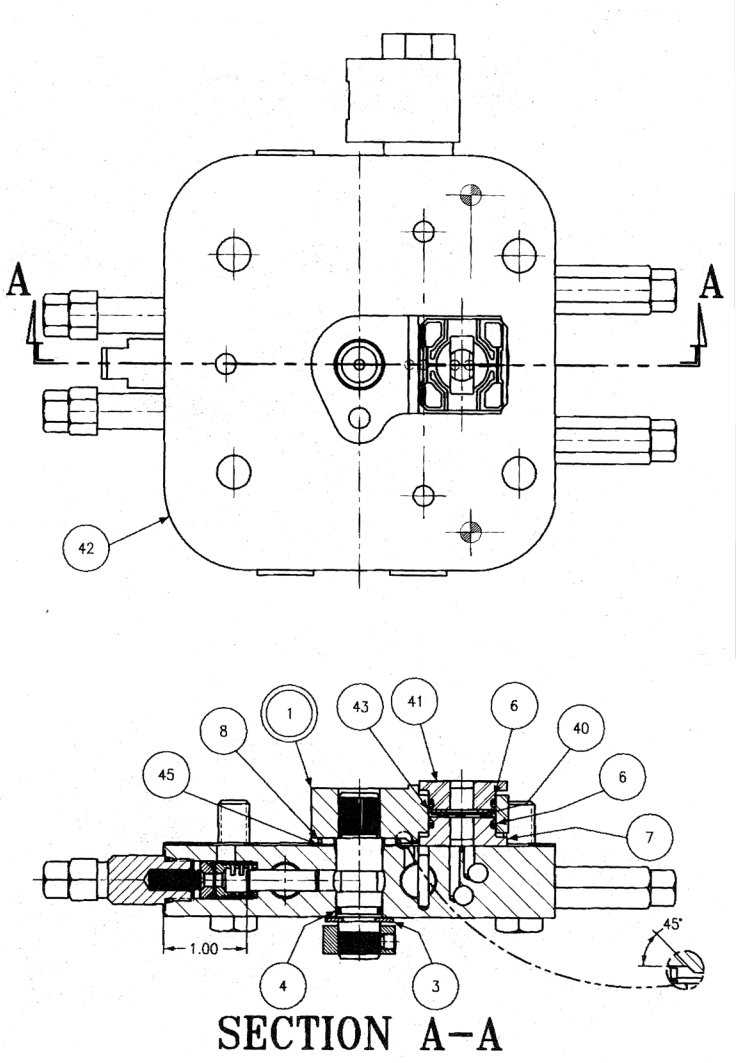
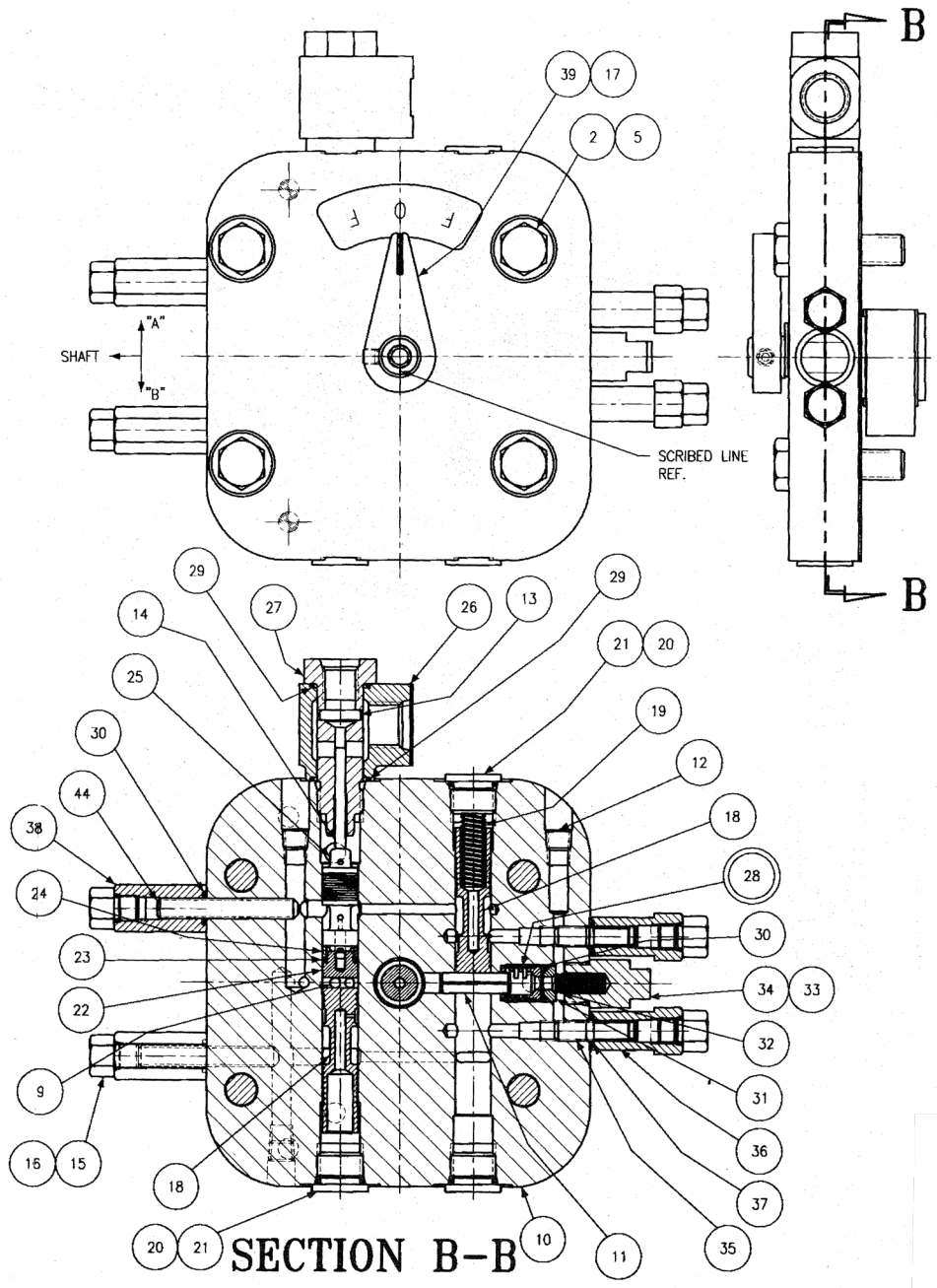

**SECTION A-A**

CCW ROTATION - "A" MTG.  
CW ROTATION - "B" MTG.

**CONTROL TORQUE LIMITER  
(1 SIDE OF CENTER)  
CW-B CCW-A**

S23-12298

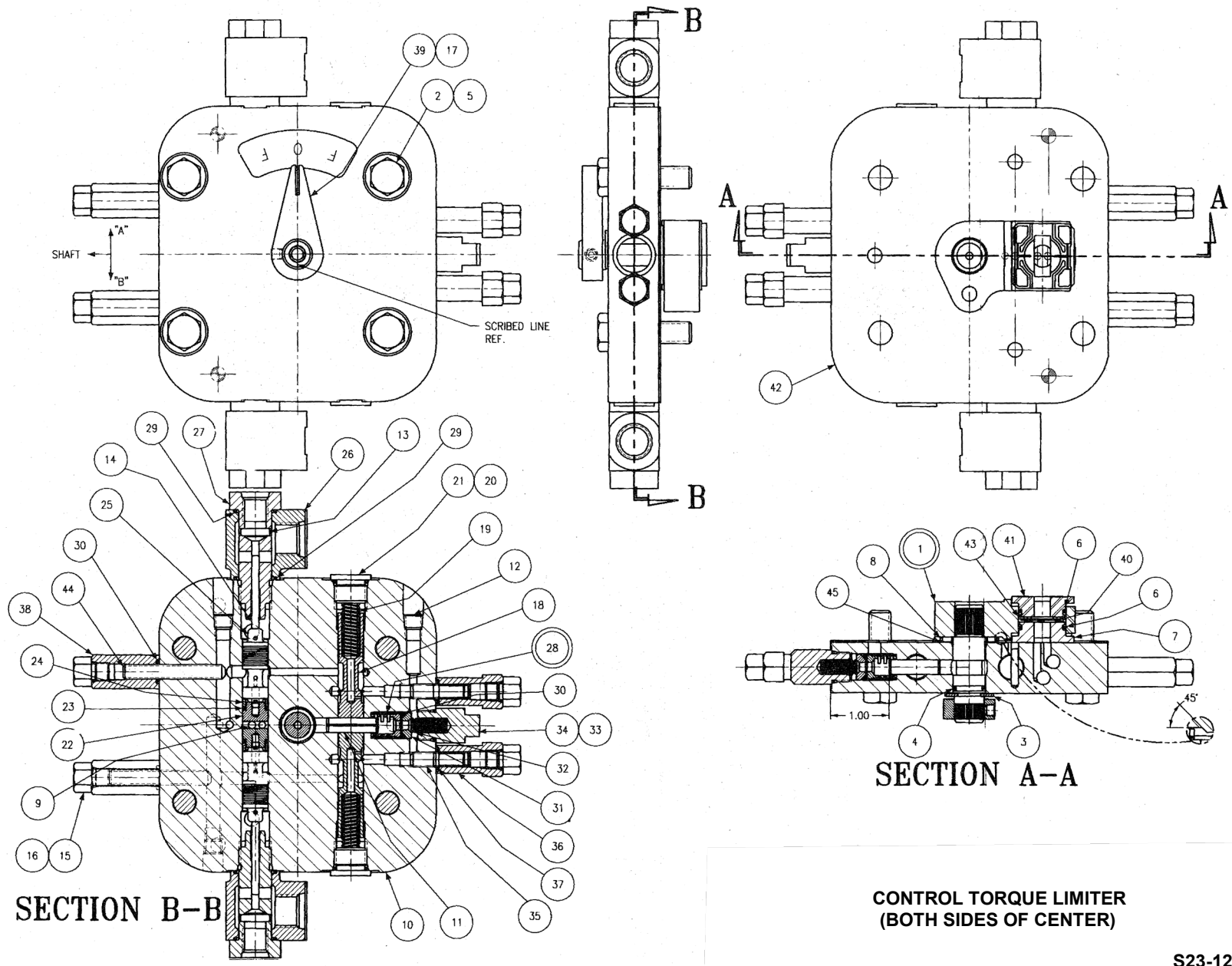

S23-12299

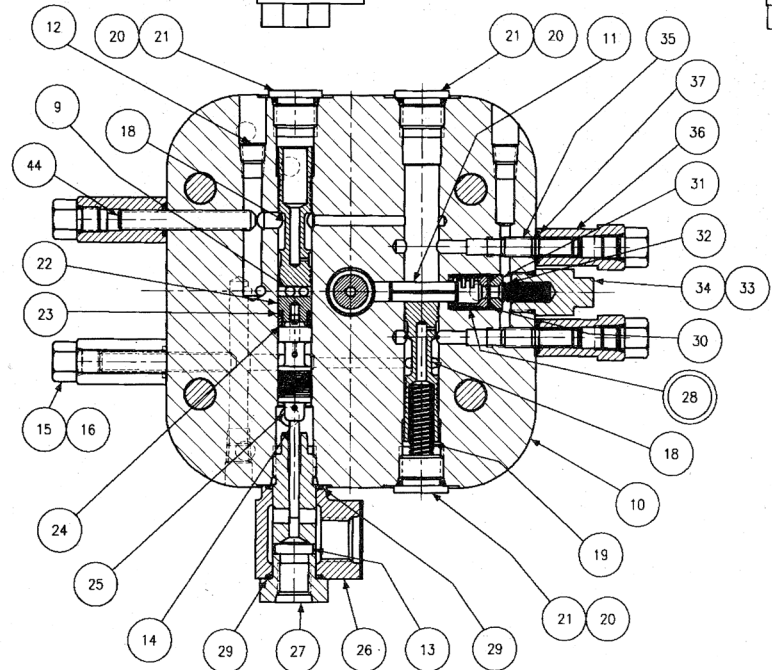
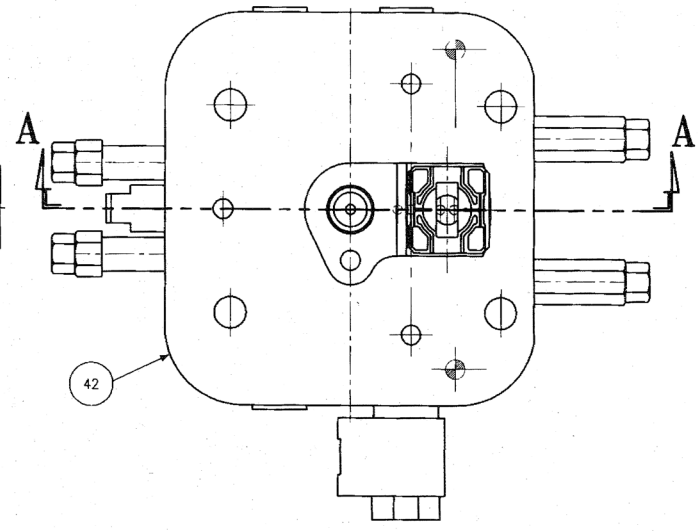
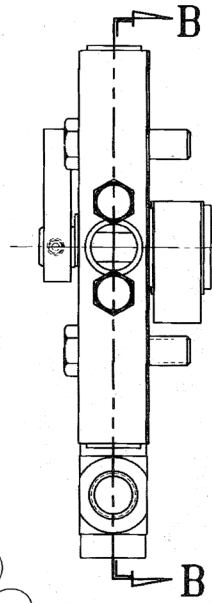
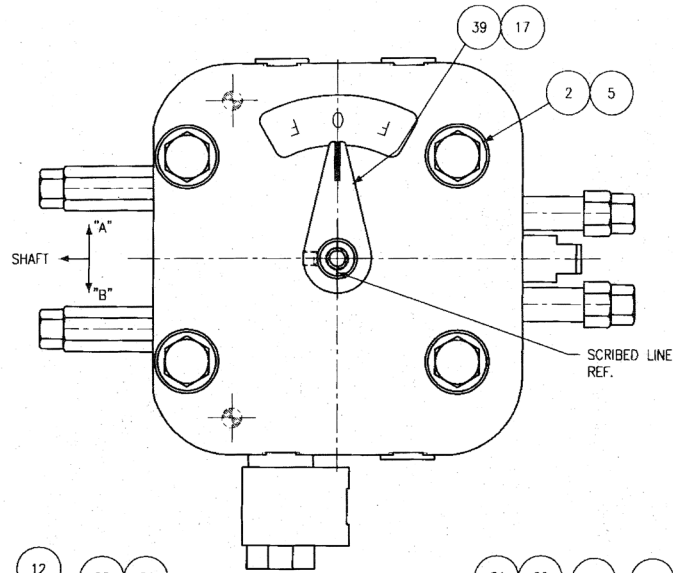

**SECTION B-B**

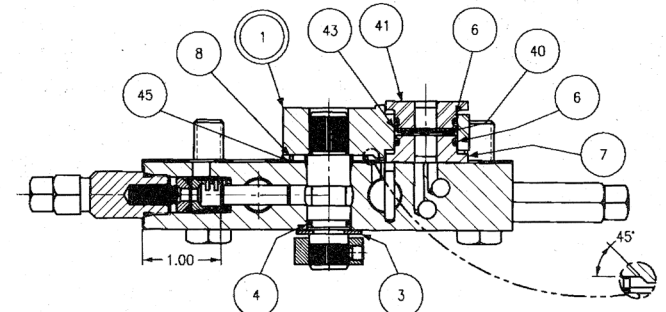

**SECTION A-A**

CW ROTATION - "A" MTG.  
CCW ROTATION - "B" MTG.

**CONTROL TORQUE LIMITER  
(1 SIDE OF CENTER)  
CW-A, CCW-B**

**S23-12300**

**STROKE INDICATOR**

S13-42064

**DESCRIPTION**

The output stroke indicator mounts on the opposite side from the input control on the pump or motor housing. The assembly contains the shoes and servo arm and shaft arrangement of the input controls. The servo arm couples to the pump cam. An indicator attached to the shaft thus indicates the cam position. Servo oil is fed to the shoes to balance the side force on the cam resulting from the shoes on the opposite side.

**DISASSEMBLY**

1. Remove screws (2). Remove cover from pump.
2. Remove indicator (12). Remove retaining ring (4) and press the shaft assembly through the valve body.
3. Examine shoes (8) and (14) for contamination in balance pads or excessive scratching on faces. Note: the two shoes are not identical and must be installed in the proper position on reassembly.

**REWORK OF WEAR PARTS**

Description	Rework
Servo plate face	Fine stone to remove raised burrs & dings
Shear seal	Fine stone to remove raised burrs & dings. Note: grooves to supply balance pads must be present and adequate.
Control cover	Stone or lap inside face to remove raised burrs & dings.

**PREPARATION FOR ASSEMBLY**

All parts are to be inspected and be free of material defects, dirt, scratches or any foreign material.  
 All parts are to be cleaned with a suitable cleaning solvent and all cores and passages blown out with clean dry compressed air.  
 After cleaning and inspection, all parts are to be covered with a light film of oil and should be protected from dirt and excessive handling until assembled onto the unit.  
 During assembly, lapped and ground surfaces should be kept lubricated and protected from nicks or surface damage.

**ASSEMBLY**

1. Apply pipe sealant and Install plug (10) in body. Torque to 100 in.-lb. (11.3 N•m)
2. Install O-ring (7) in groove of shear seal (8). Install shear seal with O-ring in the large hole on the servo link, on the servo shaft side. Be certain that the shear seal is sitting with the flange flush against the servo link surface.

Note: The shear seal will fit in one position only. Otherwise one side will be held up by the lip of the servo link. Shear seal (8) must be installed to face against the cover plate (11). This shear seal differs from shear seal (14) in that the face surface is machined with two .094" (2.4 mm) radius scallops.

3. Install three thrust washers (9) over servo shaft and seat against the servo link.
4. Install O-ring (5) in the second groove from the end of the shaft, using installation tool T-1.
5. Install the servo shaft assembly into the cover plate (11).
6. Install retaining ring (4) into the groove of the servo shaft extending through the cover plate.
7. Place two spring washers (13), nested with the bent sections matching each other, into the large hole in the servo link.
8. Place washer (19) against the spring washers.
9. Install O-ring (7) into groove in the remaining shear seal (14). Note: This shear seal does not contain the two .094" (2.4 mm) radius scallops in the face. Place on top of washer (19). Position shear seal to match the lip on the servo link.
10. Place servo link against a solid object and press indicator (12) on the servo shaft end. Align the pointer line on the indicator with the scribed line across the shaft. When the pointer is towards the letter "O", the link should be centered between the dowel pin holes on the control cover. Install screw (17).
11. To mount on unit, slip servo arm between the two spacers extending from the servo stem and align control with housing dowels. Install control on pump with screws (2), new Nyltite washers (6), and gasket (15). Torque screws to 30 ft.-lb. (40.8 N•m).

**PARTS LIST**  
For stroke indicator

ITEM	DESCRIPTION	PT. NO.	QTY.
1	Servo shaft assy.	S13-48437	1
2	Screw, hwhd. 3/8-16 x 1-1/4	353-25018	4
4	Ring, WT 5100-50	356-65070	1
5	O-ring, 70 S-1 ARP 013	671-00013	1
6	Washer, Nyltite #37	631-45007	4
7	O-ring, 70 S-1 ARP 017	671-00017	2
8	Shear seal	033-71371	1
9	Thrust washer	350-10103	3
10	Hex flush plug 1/8" pipe	431-90204	1
11	Control cover	033-53577	1
12	Indicator	033-70624	1
13	Finger spring	350-10067	2
14	Shear seal	033-70525	1
15	Control cover gasket	033-91058	1
17	Soc. setscrew, 10-32	312-09032	1
19	Thrust washer	350-10064	1

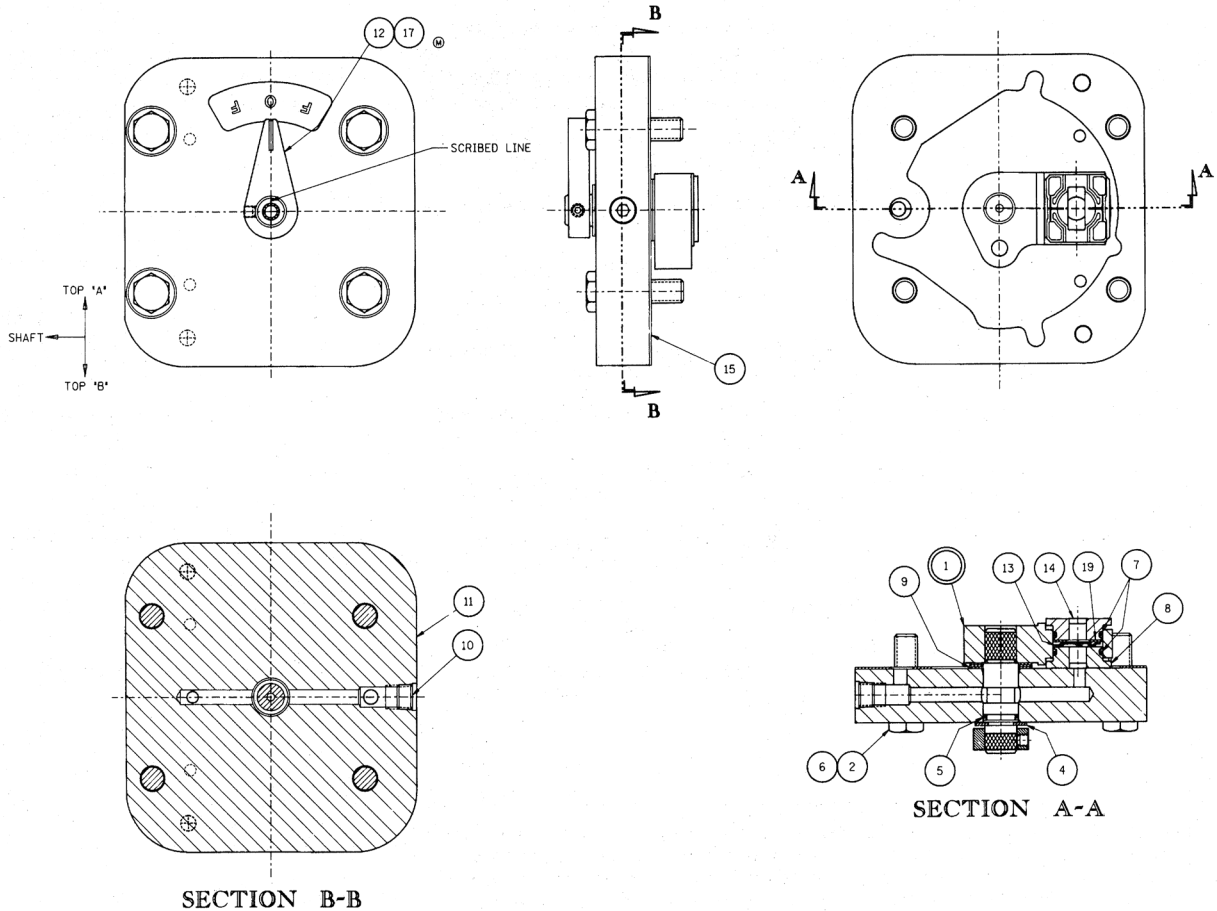

**STROKE INDICATOR**  
S13-42064

PARTS LIST

CONTROL	POWDER METAL COVER PLATE	CAST IRON COVER PLATE	N/A
	*SEAL KIT	**SEAL KIT	
10	S23-02303-0	S23-02303-0	-
2A	S23-02303-0	S23-02303-0	-
2H	S23-02303-0	S23-02303-0	-
2M			
2N			
4A	S23-023043-0	S23-023043-0	-
4B	S23-02303-0	S23-02303-0	-
4C	S23-02303-0	S23-02303-0	-
5A	S23-02304-0	S23-02304-0	-
5C	S23-02304-0	S23-02304-0	-
60	S23-02305-0	S23-02305-0	-
6A	S23-02305-0	S23-02305-0	-
6B	S23-02305-0	S23-02305-0	-
6C	S23-02305-0	S23-02305-0	-
8A/8C	-	S23-15156-0	-
9A/9C	-	S23-15157-0	-
XX4 TLO	S23-02302-0	S23-02302-0	-
REVERSE COMPENSATOR XA5	-	-	S23-05996-D

1. Add -4 for EPR and -5 for Viton Seals in place of -0.

NOTE: 5A and 5C seal kits not available with -4 or -5 seals.

5A, 5C, 9A and 9C-0 seal kits come with -5 seals as standard

\* Powdered metal covers use "O" rings to seal between the control and the housing.

\*\* Cast iron use a gasket to seal between the control and housing.

Note: All control seal kits contain both the "O" ring and gasket for either design.

**DEFINITION & UNIT**

<i>displacement</i>	$\text{in}^3/\text{rev} \times 16.387 = \text{cm}^3/\text{rev}$	$\text{cm}^3/\text{rev} \times 0.06102 = \text{in}^3/\text{rev}$
<i>flow</i>	$\text{gpm} \times 3.78 = \text{L}/\text{min}$	$\text{L}/\text{min} \times 0.2642 = \text{gpm}$
<i>power</i>	$\text{hp} \times 0.7457 = \text{kW}$	$\text{kW} \times 1.341 = \text{hp}$
<i>torque</i>	$\text{lb}\cdot\text{ft} \times 1.3567 = \text{Nm}$	$\text{Nm} \times 0.7376 = \text{lb}\cdot\text{ft}$
<i>pressure</i>	$\text{lbs}/\text{in}^2 \text{ (psi)} \times 0.06895 = \text{bar}$ $\text{lbs}/\text{in}^2 \text{ (psi)} \times 6.895 = \text{kPa}$	$\text{bar} \times 14.50 = \text{lbs}/\text{in}^2 \text{ (psi)}$ $\text{kPa} \times 0.1450 = \text{lbs}/\text{in}^2 \text{ (psi)}$
<i>weight</i>	$\text{lb} \times 0.4536 = \text{kg}$	$\text{kg} \times 2.205 = \text{lbs}$
<i>force</i>	$\text{lb} \times 4.448 = \text{N}$	$\text{N} \times 0.2248 = \text{lbs}$
<i>volume</i>	$\text{in}^3 \times 16.387 = \text{cm}^3$	$\text{cm}^3 \times 0.06102 = \text{in}^3$
<i>area</i>	$\text{in}^2 \times 6.452 = \text{cm}^2$	$\text{cm}^2 \times 0.1550 = \text{in}^2$
<i>length</i>	$\text{in} \times 25.4 = \text{mm}$	$\text{mm} \times 0.03937 = \text{in}$
<i>temperature</i>	$\frac{\text{degree F}-32}{1.8} = \text{°C}$	$1.8 \times \text{°C}+32 = \text{°F}$
<i>viscosity</i>	$\text{cSt} \times 1.0 = \text{mm}^2/\text{sec}$ $\text{SSU} \cong \text{cSt} \times 4.25 + 14$	$\text{mm}^2/\text{sec} \times 1.0 = \text{cSt}$ $20 \text{ cSt} \cong 99 \text{ SSU}$

**FLUID POWER FORMULAS**

<i>Pump input torque</i>	<i>lbs. in.</i>	$\frac{\text{pressure(psi)} \times \text{displacement (in}^3/\text{rev)}}{2\pi \times \text{mech. eff.}}$
<i>Pump input power</i>	<i>hp</i>	$\frac{\text{rpm} \times (\text{in}^3/\text{rev}) \times (\text{psi})}{395934 \times \text{overall eff.}}$
<i>Pump output flow</i>	<i>U.S. gpm</i>	$\frac{\text{rpm} \times (\text{in}^3/\text{rev}) \times \text{volumetric eff.}}{231}$
<i>Fluid motor speed</i>	<i>rpm</i>	$\frac{231 \times \text{flow rate(U.S. gpm)} \times \text{volumetric eff.}}{\text{displacement (in}^3/\text{rev)}}$
<i>Fluid motor torque</i>	<i>lbs. in.</i>	$\frac{\text{pressure(psi)} \times \text{displacement (in}^3/\text{rev)} \times \text{mech. eff.}}{2\pi}$
<i>Fluid motor power</i>	<i>hp</i>	$\frac{\text{rpm} \times (\text{in}^3/\text{rev}) \times (\text{psi}) \times \text{overall eff.}}{395934}$
<b>(metric)</b>		
<i>Pump input torque</i>	<i>Nm</i>	$\frac{\text{pressure(bar)} \times \text{displacement (cm}^3/\text{rev)}}{20\pi \times \text{mech. eff.}}$
<i>Pump input power</i>	<i>kW</i>	$\frac{\text{rpm} \times (\text{cm}^3/\text{rev}) \times (\text{bar})}{600000 \times \text{overall eff.}}$
<i>Pump output flow</i>	<i>Lpm</i>	$\frac{\text{rpm} \times (\text{cm}^3/\text{rev}) \times \text{volumetric eff.}}{1000}$
<i>Fluid motor speed rpm(min<sup>-1</sup>) (tr/mn)</i>		$\frac{1000 \times \text{flow rate (Lpm)} \times \text{volumetric eff.}}{\text{displacement (cm}^3/\text{rev)}}$
<i>Fluid motor torque</i>	<i>Nm</i>	$\frac{\text{pressure(bar)} \times \text{displacement (cm}^3/\text{rev)} \times \text{mech. eff.}}{20\pi}$
<i>Fluid motor power</i>	<i>.kW</i>	$\frac{\text{rpm} \times (\text{cm}^3/\text{rev}) \times (\text{bar}) \times \text{overall eff.}}{600000}$

"The product information specifications and descriptions contained in this catalog have been compiled for the use and convenience of our customers from information furnished by the manufacturer, and we cannot and do not accept any responsibility for the accuracy or correctness of any description, calculation, specification or information contained herein. No such description, calculated, specified or information regarding the products being sold has been made part of the basis of the bargain nor has same created or amounted to an express warranty that the products would conform thereto. **We are selling the goods and merchandise illustrated and described in this catalog on an as is basis and disclaim any implied warranty, including any warranty of merchantability or warranty of fitness for any particular purposes whatsoever, with respect to the goods and merchandise sold.** All manufacturer warranties shall be passed on to our customers, but we shall not be responsible for special, indirect, incidental or consequential damages resulting from the use of any of the products or information contained or described in the catalog."









**International Distributors**

**In Europe:**

Cyprus  
Eastern Europe  
The Faroe Islands  
Finland  
Greece  
Iceland  
Norway  
Portugal  
Switzerland  
Turkey

**In Africa:**

Algeria  
Egypt  
Ivory Coast  
Morrocco  
Nigeria  
South Africa  
Togo  
Tunisia

**In Middle East:**

Iran  
Israel  
Lebanon  
Pakistan  
Qatar  
Saudi Arabia  
Syria  
United Arab Emirates

**In Far East:**

China  
Indonesia  
Korea  
Malaysia  
New Zealand  
Philippines  
Taiwan  
Thailand

**Australia**

DENISON HYDRAULICS Pty. Ltd.  
41-43 St. Hillers Road  
P.O. Box 192  
Auburn, N.S.W. 2144  
Australia  
Tel. (612) 9646 5200  
Fax (612) 9643 1305

Other sales offices:  
Queensland  
South Wantirna Victoria  
Western Australia

**Austria**

DENISON HYDRAULIK GmbH  
Zweigniederlassung Linz  
Haidbachstraße 69  
A-4061 Pasching  
Austria  
Tel. (43) 7229 4887  
Fax (43) 7229 63092

**Benelux**

DENISON HYDRAULICS  
BENELUX B. V.  
Pascalstraat 100  
3316 Dordrecht  
Holland  
Tel. (31) 786179 900  
Fax (31) 786175 755

**Canada**

DENISON HYDRAULICS  
CANADA Inc.  
2320 Bristol Circle, Unit 1  
Oakville, ON L6H 5S2  
Canada  
Tel. (905) 829 5800  
Fax (905) 829 5805

Other sales offices:  
Montreal, QC  
Richmond, BC

**Denmark**

DENISON HYDRAULIK  
DENMARK A/S  
Industrikrogen 2  
DK-2635 Ishøj  
Denmark  
Tel. (45) 4371 15 00  
Fax (45) 4371 15 16

**Finland**

DENISON HYDRAULICS  
P.O. Box 1096  
Alhotie 24  
FIN-04431 Järvenpää  
Finland  
Tel./Fax (358) 0 2710 588

**France**

DENISON HYDRAULICS  
FRANCE SA  
14, route du Bois Blanc  
BP 539  
18105 Vierzon  
France  
Tel. (33) 2/48 53 01 20  
Fax (33) 2/48 75 02 91

Other sales offices:  
Bordeaux  
Lyon  
Paris

**Germany**

DENISON HYDRAULIK GmbH  
Gerresheimer Straße 93  
D-40721 Hilden  
Germany  
Tel. (49) 2103 3090  
Fax (49) 2103 309211

Other sales offices:  
Dresden  
Hanover  
Stuttgart

**Great Britain**

DENISON HYDRAULICS U.K.  
Ltd.  
Kenmore Road  
Wakefield 41, Industrial Estate  
Wakefield, WF20XE  
West Yorkshire  
England  
Tel. (44) 19 24 826 021  
Fax (44) 19 24 826 146

Other sales offices:  
Burgess Hill

**Hong Kong & P. R. China**

DENISON HYDRAULICS Ltd.  
Unit 2, 25/F Wharf Cable Tower  
9 Hoi Shing Road  
Tsuen Wan  
N.T., Hong Kong  
Tel. (852) 24988381  
Fax (852) 24991522

**Italy**

DENISON HYDRAULICS ITALY S.r.l.  
Viale Europa 68  
20090 Cusago  
Milano,  
Italy  
Tel. (39) 2 90330 1  
Fax (39) 2 90390 695

**Japan**

DENISON JAPAN Inc.  
4-2-1 Tsujido-Shinmachi  
Fujisawa 251,  
Japan  
Tel. (81) 466 35 3257  
Fax (81) 466 35 2029

Other sales office:  
Osaka

**Mexico, Central America, South America and Caribbean Countries Contact**

DENISON HYDRAULICS Inc.  
6167 NW 181 Terrace Circle North  
Miami, FL 33015  
USA  
Tel. (305) 362 2246  
Fax (305) 362 6220

**Singapore**

DENISON HYDRAULICS S.E.A. Pte.  
Ltd.  
No. 11 Lorong Tukang Dua  
Singapore 2261  
Tel. (65) 2687840  
Fax (65) 2687847

**Spain**

DENISON HYDRAULICS, S.A.  
Gomis, 1  
08023 Barcelona  
Spain  
Tel. (34) 3418 46 87  
Fax (34) 3211 65 07

Other sales offices:  
San Sebastian

**Sweden**

DENISON HYDRAULICS  
SVENSKA AB  
Sporregatan 13  
213 77 - Malmö  
Sweden  
Tel. (46) 40 21 04 40  
Fax (46) 40 21 47 26

Other sales offices:  
Spånga

**USA**

DENISON HYDRAULICS Inc.  
14249 Industrial Parkway  
Marysville, OH 43040  
USA  
Tel. 937 644 3915  
Fax 937 642 3738  
For nearest Distributor:  
Call toll free 1 800 551 5956  
E-Mail address:  
DENISONHYD@AOL.COM  
WWW address-  
<http://www.DenisonHydraulics.com>

Other sales offices:  
Trabuco Canyon, CA  
Mulberry, FL  
Moline, IL  
Rock Island, IL  
Medina, OH  
Portland, OR  
Arlington, TX  
Houston, TX

**Other European, Middle East and African Countries Contact**

DENISON HYDRAULICS  
FRANCE SA  
14, route du Bois Blanc  
BP 539  
18105 Vierzon Cedex  
France  
Tel. (33) 2/48 53 01 20  
Fax (33) 2/48 75 02 91

Your local DENISON representative