



Instruction Book

PARKER PRO DISPLAY 10

Publ. No. MSG17-4020-IB/UK

Edition 11/2022





Parker Hannifin Manufacturing Finland Oy
Electronic Motion & Controls Division (EMC)
Electronic Controls Business Unit (ECBU)
Lepistökatu 10
FI-30100 Forssa, Finland
Office +358 (0)20 753 2500

<http://www.parker.com/emc>

Copyright 2015-2022 © Parker Hannifin Corporation. All rights reserved. No part of this work may be reproduced, published or distributed in any form or by any means (electronically, mechanically, photocopying, recording or otherwise), or stored in a database retrieval system, without the prior written permission of Parker Hannifin in each instance.



WARNING!

FAILURE OR IMPROPER SELECTION OR IMPROPER USE OF THE PRODUCTS AND/OR SYSTEMS DESCRIBED HEREIN OR RELATED ITEMS CAN CAUSE DEATH, PERSONAL INJURY AND PROPERTY DAMAGE.

This document and other information from Parker Hannifin Corporation, its subsidiaries and authorised distributors provide product and/or system options for further investigation by users with technical expertise. It is important that you analyse all aspects of your application and review the information concerning the product or system in the current product catalogue. Due to the variety of operating conditions and applications for these products or systems, the user, through their own analysis and testing, is solely responsible for making the final selection of the products and systems and assuring that all performance, safety and warning requirements of the application are met.

The products described herein, including without limitation, product features, specifications, designs, availability and pricing, are subject to change by Parker Hannifin Corporation and its subsidiaries at any time without notice.

Contents

Contents	3
Publication History.....	5
1. Introduction	6
1.1. Safety symbols.....	6
1.2. Overview of relevant documentation.....	6
2. Precautions.....	7
2.1. General safety regulations	7
2.2. Safety	7
2.3. Welding after installation	7
2.4. Construction regulations	7
2.5. Safety during installation	7
2.6. Safety during start-up.....	8
2.7. Safety during maintenance and fault diagnosis	8
3. Diagram Conventions	9
4. Product Description	11
4.1. General	11
4.2. System overview	14
4.3. Infotainment	15
4.3.1. Audio line input	15
4.3.2. Audio line output.....	16
4.3.3. Microphone input	18
4.3.4. FM radio tuner	18
4.3.5. Wireless communication.....	18
4.3.5.1. WLAN 802.11	18
4.3.5.2. Bluetooth.....	19
4.4. Video inputs	19
4.5. Inputs/Outputs.....	20
4.5.1. Ignition input	20
4.5.2. Wake-up input.....	21
4.5.3. Supply output.....	21
4.5.4. Digital output.....	22
4.6. Communication	22
4.6.1. CAN	22
4.6.2. USB	23
4.6.3. RS232.....	24
4.6.4. Ethernet	24
4.7. HMI (Human-Machine Interface).....	24
4.7.1. Touchscreen	24
4.7.2. Display	25
4.8. Internal features & diagnostics.....	26
4.8.1. Acceleration sensor.....	26
4.8.2. Supply supervision & voltage measurement	26



4.8.3. Real time clock	26
4.8.4. EEPROM	26
4.9. Mass storage.....	27
5. Software.....	28
5.1. General	28
5.2. Parker UX Toolkit.....	28
5.2.1. Parker UX Platform (UXP)	28
5.2.2. Parker Application Designer	28
5.3. UXP Configuration	28
5.4. Installing and removing applications	29
5.5. Pro Display operation modes	30
5.5.1. Sleep mode.....	31
5.6. Diagnostics.....	31
6. Mechanics.....	32
6.1. Mechanical construction	32
6.2. Dimensional drawing.....	32
7. Mounting.....	33
7.1. Mounting the module	33
7.1.1. Assembly surface considerations	33
7.2. Dashboard or panel assembly	33
7.2.1. Panel assembly	33
7.3. Ball / swivel mount	35
8. Installation	37
8.1. Electrical connections	37
8.1.1. Main connectors C1 and C2	38
8.1.2. USB connections C3 and C4.....	39
8.1.3. Video connection C5	40
8.1.4. Ethernet connection C6	41
8.1.5. Micro SD card interface	42
8.1.6. Radio antenna connection	45
8.2. Power supply considerations	46
8.2.1. Supply voltage	46
8.2.2. Emergency stop.....	46
8.2.3. Connecting of supply voltage	46
8.2.4. RTC back-up supply	46
8.2.5. Polarity reversal	47
9. Start-up	47
9.1. Procedures with software.....	47
10. Appendix A – Technical summary	48
11. Appendix B – Environmental summary	51
12. Appendix C - Ordering codes	56

Publication History

The following table provides an overview of the changes made to this document over the course of its publication history.

Table 1: Publication history

Release Date	Description of Change
06/2016	First release of this document
30/09/2016	Document update based on Forssa ECDE internal reviews
11/10/2016	Edition 10/2016 released
29/11/2016	Edition 11/2016 released
3/1/2017	Edition 1/2017 released
22/1/2020	Edition 1/2020 released
07/11/2022	Edition 11/2022 released

1. Introduction

Do not perform the procedures in this manual unless you have experience in the handling of electronic equipment.

Contact the manufacturer if there is anything you are unsure of, or if you have any questions regarding the product and its handling or maintenance.

The term "manufacturer" refers to Parker Hannifin Corporation.

1.1. Safety symbols

The following symbols are used in this document to indicate potentially hazardous situations:

 *Danger! Risk of death or injury.*

 *Warning! Risk of damage to equipment or degradation of signal.*

 *Warning! Risk of damage to equipment or degradation of signal.*

When you see these symbols, follow the instructions carefully and proceed with caution.

 *Note (character style): Note style for regular manual text.*

1.2. Overview of relevant documentation

The following publications are relevant for users of this product. The main documentation contains information that is not found elsewhere.

The additional documentation contains product information in a compact format. For details on the information found in those documents, please consult this manual.

Table 2: Pro Display 10 and UX Toolkit documentation

Document	Description
Instruction Book, Parker Pro Display 10	MSG17-4020-IB/UK (This document)
Parker Pro Display Catalogue	MSG17-4015-UK
Parker UX Toolkit Catalogue	HY33-4812-UK
Installation Sheet, Parker Pro Display 10	MSG17-4020-IS/UK
System Certification Guide	HY33-4812-SCG/UK
R10-050108 E-Type Approval, Pro Display 10	Delivered by customer request

2. Precautions

2.1. General safety regulations

Work on the hydraulics control electronics may only be carried out by trained personnel who are well-acquainted with the control system, the machine itself and its safety regulations.

Follow the manufacturer's regulations when mounting, modifying, repairing and maintaining equipment. The manufacturer assumes no responsibility for any accidents caused by incorrectly mounted or incorrectly maintained equipment. The manufacturer assumes no responsibility for the system being incorrectly applied, or for the system being programmed in a manner that jeopardizes safety.

2.2. Safety

Do not use the product if electronic modules, cabling or connectors are damaged or if the control system shows error functions. Electronic control systems in an inappropriate installation and in combination with strong electromagnetic interference fields can, in extreme cases, cause an unintentional change in the speed of the output function.

2.3. Welding after installation

Complete as much as possible of the welding work on the chassis before the installation of the system. If welding has to be done afterwards, proceed as follows:

- Do not place the welding unit cables near the electrical wires of the control system.
- Disconnect the electrical connections between the system and external equipment.
- Disconnect the negative cable from the battery.
- Disconnect the positive cable from the battery.
- Connect the welder's ground wire as close as possible to the point of welding.

2.4. Construction regulations

The vehicle must be equipped with an emergency stop which disconnects the supply voltage to the control system's electrical units. The emergency stop must be easily accessible to the operator. If possible, the machine must be built so that the supply voltage to the control system's electrical units is disconnected when the operator leaves the operator's station.

2.5. Safety during installation

Incorrectly positioned or incorrectly mounted cabling can be influenced by radio signals, which can interfere with the functions of the system.

2.6. Safety during start-up

⊗ *Danger! Risk of death or injury.*

Do not start the machine's engine before the control system is mounted and its electrical functions have been verified. Do not start the machine if anyone is near the machine.

Ensure that no one is in front of, behind or nearby the machine when first starting up the machine. Follow the instructions for function control in the Start-up section.







2.7. Safety during maintenance and fault diagnosis







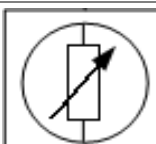

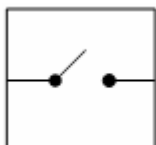
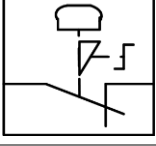
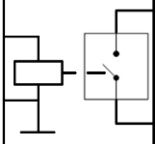
Before performing any work on the hydraulics control electronics, ensure that:

- The machine cannot start moving.
- Functions are positioned safely.
- The machine is turned off.
- The hydraulic system is relieved from any pressure.
- Supply voltage to the control electronics is disconnected.

3. Diagram Conventions

There are many connection diagrams to be found throughout this manual. The following table provides meanings for the different symbols used in those diagrams:

Symbol	Meaning
	General input
	General output
	Frequency input
	Analogue input
	Frequency sensor
	Resistive sensor
	General sensor
	Application switch
	Emergency stop
	Relay

Symbol	Meaning
	Load
	Resistor
	Pull-down resistor
	Pull-up resistor
	Diode
	Battery
	Fuse
	Ground
	Chassis ground

4. Product Description

4.1. General

Pro Display 10 is a member of Parker’s Pro Display product family. Pro Display is a family of displays capable of running Parker UX Platform (UXP) applications created with Parker Application Designer software development environment.



Figure 1: Pro Display 10

Table 3: Pro Display 10 product variants

Item	Description
88PROD10AS10	Pro Display 10 Advanced - with infotainment features, iMX6 Dual core, 1GB RAM & 2GB Flash memory.
88PROD10AIS10	Pro Display 10 Advanced - with infotainment features, iMX6 Dual core, 1GB RAM & 2GB Flash memory, + ISOBUS SUITE software installed.
88PROD10AD10	Pro Display 10 Development unit - with full feature set (similar to Advanced version). Only for development use.

The following table summarises the characteristics offered by this product:

Table 4: Pro Display 10 product characteristics

Characteristic	Value
CPU	Freescale iMX6, Cortex A9 Dual
RAM	1GB
FLASH	2GB (4GB eMMC used in SLC mode)
EEPROM	32KB in main carrier for production data saving
External memory interface	SD host interface for Micro SD/SDHC Card (in the back side of the module, sealed with cover plug)
Communication media	1 x Ethernet 10 or 100 Mbps speed 4 x CAN 2 x USB 2.0 1 x RS232 1 x Bluetooth 1 x WLAN
Video input	2 x Composite video inputs with NTSC/PAL/SECAM autodetection
Audio	Stereo Line IN & Line OUT Audio input sources (5 pcs) selectable from following: a) Bluetooth audio b) Audio line input (selectable with FM radio) c) FM radio (selectable with audio line input) d) Microphone input e) Digital audio from module Audio outputs (2 pcs) selectable from following: a) Audio line output (to external amplifier) b) Digital audio to module (record). As default recording is disabled.
FM-Radio & antenna connector	Yes
Microphone inputs	Yes
Digital inputs	1 x Keylock (ignition) input 1 x Wake-up input
Outputs	1 x High-side output: 200mA max 1 x Camera supply output 12V / 1A max
Internal features	3-axis acceleration sensor Voltage measurement Real Time Clock (RTC)
Operating voltage range	6...36VDC (12/ 24V nominal)
Operating temperature range	-30 °C ... +70 °C
Storage temperature range	-40 °C ... +85 °C
IP rating	IP65
Display type	TFT, Transmissive with LED backlight
Display size	10,1 inch LCD active area: 216,96 x 135,6 mm



Characteristic	Value
Display features	Resolution: 1280 x 800 Luminosity / brightness: 400 cd/m2 (Typical) Contrast ratio: 800:1 (Typical)
Touchscreen	Projected capacitive touchscreen (PCAP) Sensor active area: 218,96 x 137,6 mm Multi-finger support
Cover glass features	Thickness: 1,8 mm Glass type: hardened Printing: ceramic or silk printing on edges Surface treatment: anti-glare
Touchscreen – display mechanical interface	Optical bonding between cover glass and LCD display glass for improved optical performance.
Product size	264 x 181 x 52 mm (width, height, depth)
Case material	Front cover: PC-ABS Back cover: Die casted Aluminium
Weight	1,42 kg

This manual describes the hardware components of the Pro Display 10, but it does not explain how to configure nor develop the actual application software. For more information about software, please refer to the appropriate software manual or contact your Parker Account Representative.

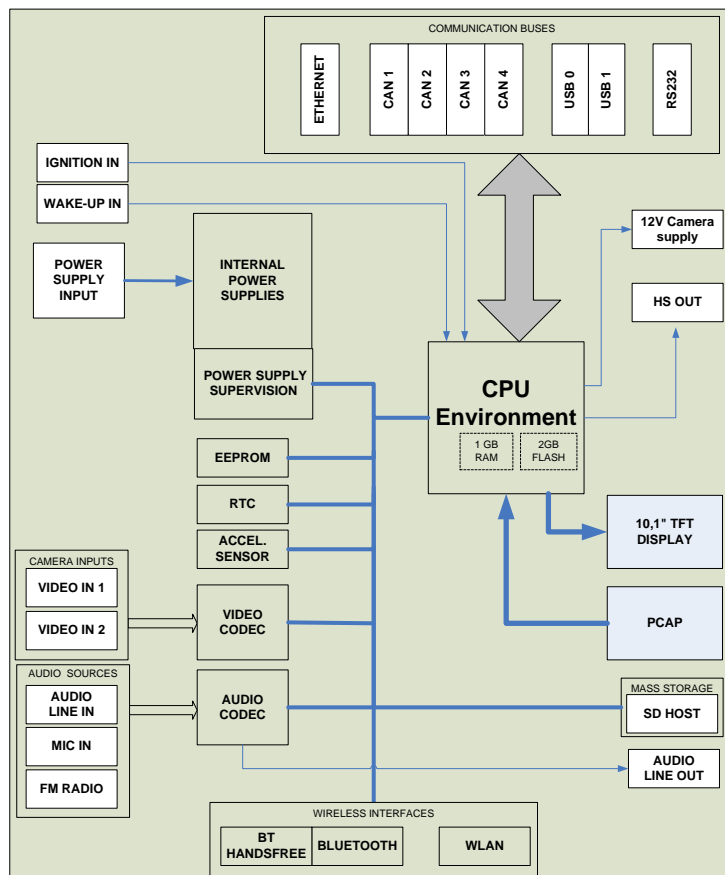

Figure 2: Pro Display block diagram

4.2. System overview

Parker Pro Display can be a central Human Machine Interface (HMI) unit in the system or a stand-alone display. Pro Display is not limited to one particular control system integration. Pro Display has four CAN buses, one Ethernet port, two USB ports, one RS232 port, two video inputs and digital ignition and wake-up inputs. SAE J1939 and Generic CAN protocols are supported on the CAN buses, which allows for the possibility to connect Pro Display to third party modules.

Pro Display also supports WLAN and Bluetooth wireless communications and therefore it can be connected to mobile phones, tablets, laptop computers etc. for audio streaming, video sharing and overall data communication between the devices.

HMI is implemented by a projective capacitive touchscreen and a high performance TFT-LCD display panel. All I/O are protected against short circuit to GND and VBatt as well as against reverse polarity. Pro Display is intended for systems using either nominal 12 or 24VDC voltage. The unit has a wide supply voltage range – from 6 to 36VDC.

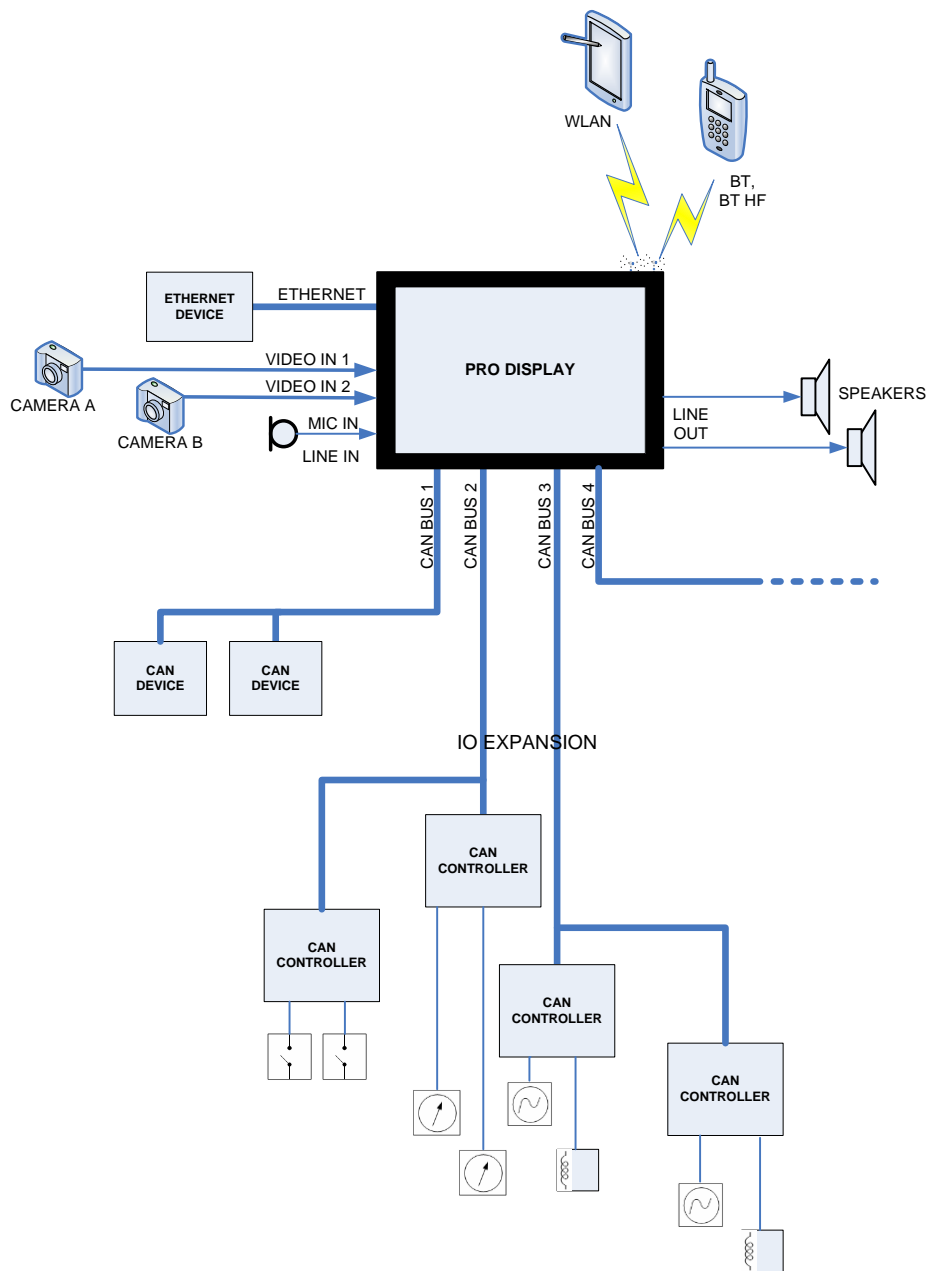

Figure 3: Pro Display system overview. This figure shows just one possible application.

4.3. Infotainment

4.3.1. Audio line input

This product has one unbalanced stereo line input: “Audio Line IN”. Audio input volume is adjustable through the use of software. Microphone input and warning tones can be mixed to any selected audio source.

There are five different audio sources to be selected:

- Bluetooth audio

- Audio line input (selectable with FM radio)
- FM radio (selectable with audio line input)
- Microphone input (internally connected to audio codec and Bluetooth module)
- Module internal (digital audio from module)

Table 5: Audio Line IN specifications

Feature	Spec
DC input impedance	13,3 kOhm
Maximum input voltage	1 Vrms
Bandwidth	4 – 28 kHz/-3dB

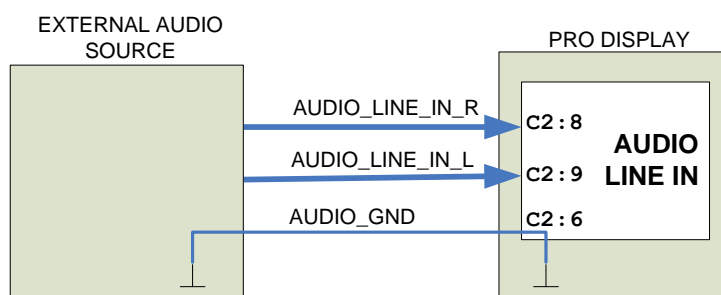

Figure 4: Line input

4.3.2. Audio line output

There is one optional unbalanced stereo line output that is able to connect to an external amplifier. Output amplitude can be adjusted through the use of software.

There are two audio outputs to be selected:

- Audio line output (to external amplifier)
- Digital audio to module (record). Recording is disabled by default in Pro Display.

Table 6: Audio Line OUT specifications

Feature	Spec
Output impedance	150 Ohm
Maximum output voltage	0,5 Vrms
Bandwidth	7 Hz – 20 kHz /-3 dB

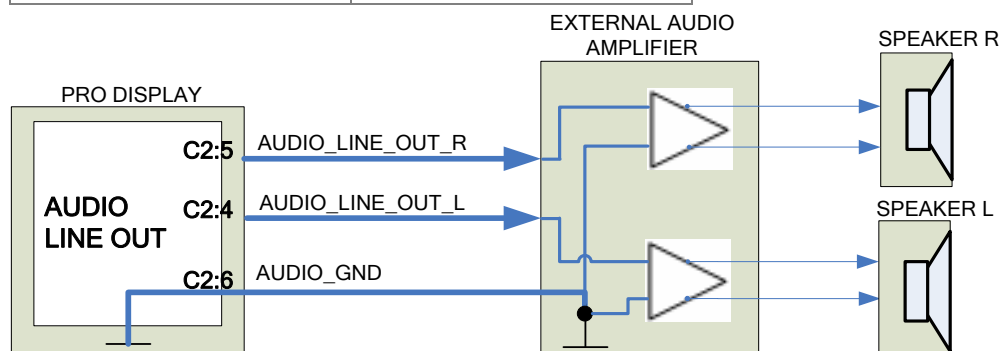



[Header Link to Contents](#)

Figure 5: Pro Display line output. Picture shows connection principle for two channels. It is possible to also utilise single channel if this would be adequate for the end application.

4.3.3. Microphone input

Microphone input is provided. Microphone input can be used for both general and hands-free purposes. Microphone input volume is adjustable with software. This input has a bias voltage output for electret microphones.

Table 7: Microphone input- specifications

Feature	Spec
DC input impedance	2 kOhm
Maximum input voltage	215 mVrms
Bandwidth	35 Hz – 16 kHz/-3 dB
Bias voltage:	2,5V (typical)

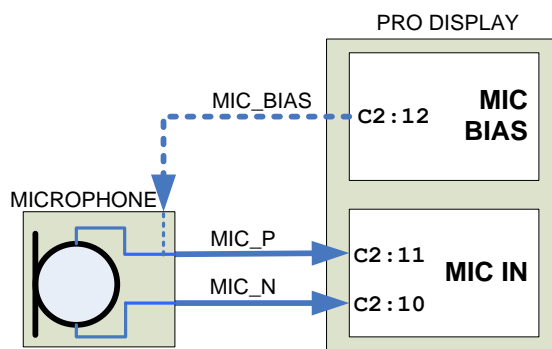

Figure 6: Pro Display microphone input

4.3.4. FM radio tuner

RDS FM radio tuner is one of the audio sources in Pro Display. A connector for attaching an external antenna into Pro Display is also provided. FM radio feature is selectable so that either FM radio or Audio line inputs serve as the audio source.

Pro Display radio includes complete RDS-FM tuner functionality with seek tuning within 76 to 108 MHz frequency range, automatic frequency and gain control features, as well as volume control and adaptive noise suppression.

! *NOTICE: Check the supported software features for RDS-FM Radio before application software creation.*

4.3.5. Wireless communication

4.3.5.1. WLAN 802.11

Pro Display can be connected to wireless local area network (WLAN) access points. This makes it possible to connect to external networks via mobile phone and use, for example, online map provider services. Standards IEEE 802.11b, 802.11g and extension 802.11n are supported.

Parker has an example application called “Settings”. This example application can be used for scanning available access points and to make connections with desired access points.

4.3.5.2. Bluetooth

Pro Display includes wireless Bluetooth function to connect other Bluetooth devices. Bluetooth supports for example Serial Port Profile (SPP), Hands Free Protocol (HFP) and Advanced Audio Distribution Profile (A2DP) for audio streaming.

! *NOTICE: If echo cancelling functionality for hands-free is needed, please contact your Parker Account Representative.*

It is also possible to connect a Bluetooth device to Pro Display and transfer, for example, diagnostic data via serial port protocol.

! *NOTICE: Connected device shall have suitable application for allowing wireless data transfer to/from Pro Display.*

4.4. Video inputs

Pro Display has 2 pcs of analogue composite video inputs, CVBS IN 1 and CVBS IN 2, with NTSC/PAL/SECAM autodetection. There is also a supply output for external cameras – see details of this in chapter 4.5.3.

Table 8: Video input specifications

Feature	Spec
Signal level	1,9 Vp-p (typical)
Input impedance	75 Ohm

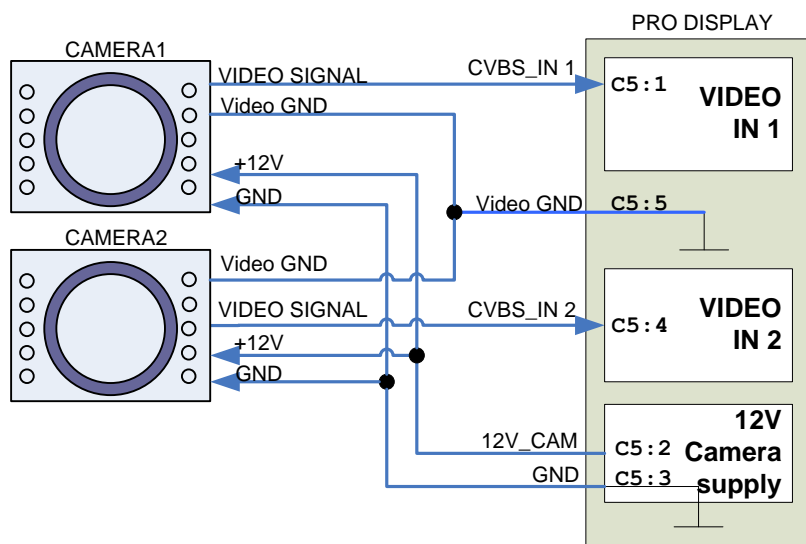

Figure 7: Video Camera connection principle for 2 cameras

4.5. Inputs/Outputs

4.5.1. Ignition input

One ignition (keylock) input is provided and it has following specifications:

Table 9: Ignition input- specifications

Feature	Spec
Input voltage range ON	> 6V
Input voltage range OFF	< 3V
Input voltage tolerance	± 10 %
Input voltage range to enter Maintenance mode	> 36V
Cut-off frequency	102 Hz
Input impedance	38 kΩ

When VBatt is disconnected the module cannot be powered through ignition. This multi-level, digital ignition signal has following functional states:

Table 10: Ignition- signal functionality

State	Functionality
OFF	Inactive; the main power is switched off if the internal 'Keep alive' control signal is off.
ON	Active; switches the main power on, or wakes the module up from sleep
MAINTENANCE	Used for software download and service purposes

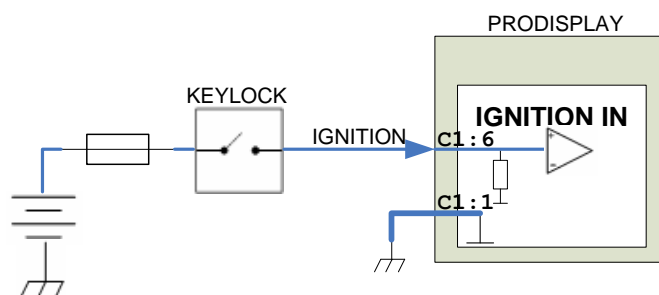

Figure 8: Ignition input connection principle

Maintenance mode is intended for the following:

- Installing new software packages
- Updating existing software packages
- Removing existing software packages

4.5.2. Wake-up input

One wake-up input is provided and it has following specifications:

Table 11: Wake-up input- specifications

Feature	Spec
Input voltage, HIGH level	>5,9V
Input voltage, LOW level	<3,0V
Input voltage tolerance	±10 %
Cut-off frequency	20 Hz
Input impedance	38 kΩ

The wake-up signal can be used to wake the module up from sleep mode. Being in a state of ignition does not affect “wake-up from sleep mode” functionality. Wake-up does not turn the unit on when the unit is fully powered down – e.g. this feature is only used with sleep mode.

In operation mode this input can be used as digital input.

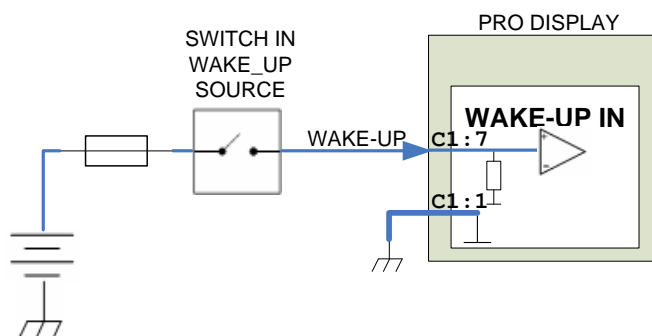

Figure 9: Wake-up input connection principle

4.5.3. Supply output

There is one power supply out for external cameras. This camera supply provides 12VDC with a maximum current of up to 1A. It is also short circuit protected in cases of short to ground. Pro Display has internal short circuit protection for this supply output.

This supply output is software-controlled and therefore can be inhibited if it is not required by the system/application.

Table 12: 12V Camera supply specifications

Feature	Spec
Output voltage range	12V ±600mV
Output current max.	1A

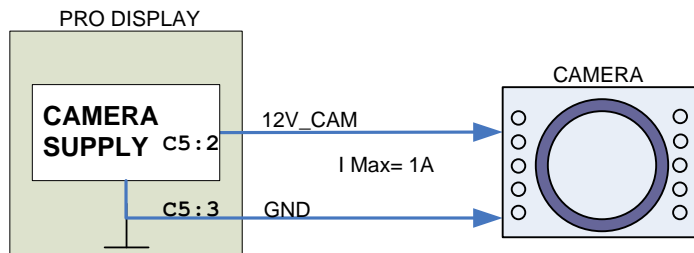

Figure 10: Camera supply output. When there is second camera in the end application, the branching of the supply wires shall be implemented in a wire harness – see more about this in figure 7, chapter 4.4.

4.5.4. Digital output

One high-side output is available, providing 200mA max. output current. This output can be used, for example, as an audio amplifier wakeup, to control an external buzzer or for signalling other external devices.

Table 13: High-side output specifications

Feature	Spec
Output current	200mA
ON- state	VBatt – 0,7V (100mA load) VBatt – 0,25V (no load)
OFF- state	0V (100mA load) 0,15V (no load)

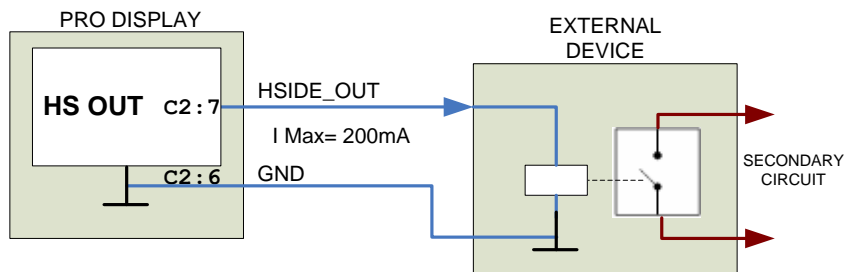

Figure 11: High-side output connection principle. This shows just one use case for this output; an external device can also be an indicator etc.

4.6. Communication

4.6.1. CAN

Pro Display has four CAN buses (ISO 11898). These buses can be used with various protocols, according to OEM's needs. Parker currently supports J1939 protocol in Pro Display. OEM can implement other necessary protocols. All CAN buses have software-controlled termination.

NOTICE: Internal CAN termination is controlled by application software and therefore it is not enabled during boot-up. This shall be taken into account in end application design. If Pro Display SW controlled CAN termination is not feasible for end application, then external termination resistors shall be used.

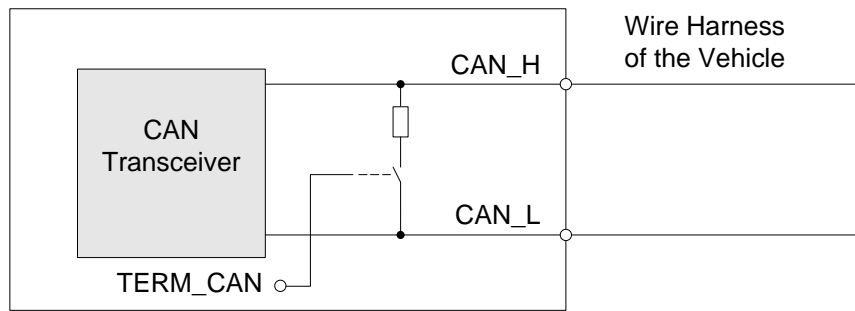

Figure 12: Software controllable CAN termination feature in Pro Display

For a list of J1939 connection considerations, refer to the SAE J1939 specifications available through the Society for Automotive Engineers. J1939-11 covers the physical aspects of the CAN bus, including cable type, connector type and cable lengths.

NOTICE: CAN bus maximum speed depends on physical bus length and other characteristics of the network.

4.6.2. USB

There are two USB-host ports in Pro Display following USB 2.0 specification. These are available for the user and can be used for:

- Upgrading the application SW with USB memory stick
- Downloading data into module
- Downloading infotainment-related content (music, video clips, etc.) into module.

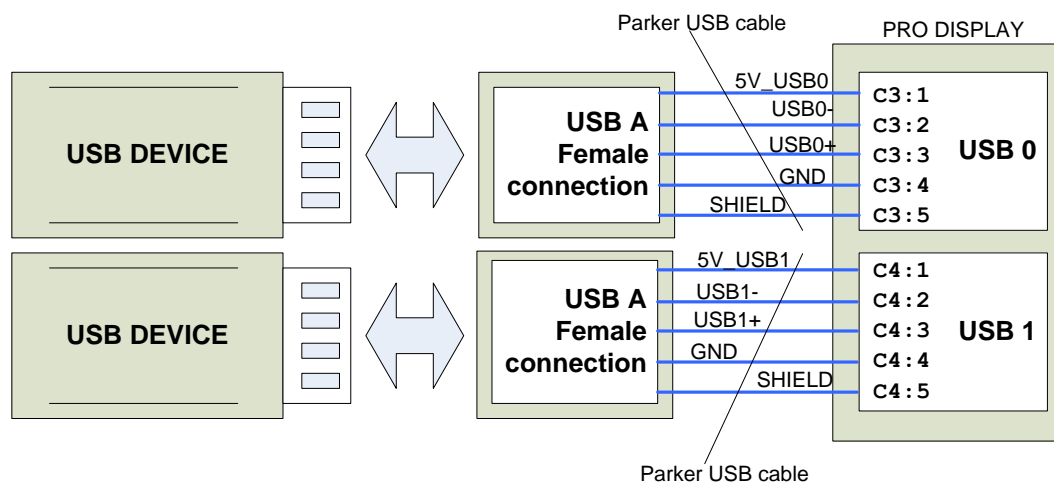

Figure 13: USB device/stick connection. USB 0 & USB 1 interfaces utilises M12 connector in Pro Display. M12 to USB cable adapter is available from Parker and the interface can be brought into the dashboard or other suitable place in the vehicle cabin.

NOTICE: Possible IP rating requirements in end application shall be considered by OEM. Usually, USB device is for short-term usage. USB interface protection, according to OEM's required IP rating, outside of the Pro Display shall be taken into account in the end application environment.

4.6.3. RS232

One RS232 port is provided and available on main connector C2. The port consists of TX, RX and GND signals. There is no handshaking. Baud rate is configurable up to 115200 bps.

4.6.4. Ethernet

Pro Display has one IEEE 802.3 compliant 10/100 Ethernet interface. Possible baud rates are 10 or 100Mbps. Ethernet port can be designated for computer communication as well as uploading or downloading applications and diagnostics, or it can be used for an in-vehicle network over Ethernet in cases of devices with Ethernet connections.

Static IP address setting and DHCP client are supported.

4.7. HMI (Human-Machine Interface)

Human–Machine Interface consists of projective Capacitive Touchscreen (PCAP) and high resolution TFT LCD display.

4.7.1. Touchscreen

Projective Capacitive Touchscreen (PCAP) supports multipoint finger and stylus-touch. Pro Display is intended for in-cabin use. Unit will not be damaged by water as it has IP65 rated ingress protection.

Touchscreen may have limited functionality if excessive amount of water gets onto the touchscreen. Therefore, it's always best practice to ensure that water droplets are able to roll off of the screen by placing the display in a vertical or at least a slightly angled position in the end application environment. Touch sensor is tuned to reduce the risk of unintentional activation by, for example, water droplets.

Display glass can be cleaned with an LCD cleaning solution and cloth. Use a non-abrasive cloth for cleaning the display.

! *NOTICE: To avoid scratches, do not wipe or clean a dry display.*

! *NOTICE: Reasonable care should be taken to maintain the glass.*

Table 14: Touchscreen specifications

Feature	Specification
Sensor active area	218,96 x 137,6 mm
Cover glass	Thickness: 1,8 mm Glass type: Strengthened Printing on cover glass edges Anti-glare surface treatment
Touchscreen	Projected Capacitive Touchscreen
Features	Multi-finger support

4.7.2. Display

Pro Display 10 uses a high-performance 10,1" IPS colour TFT LCD with white LED backlight. The 10,1" display is widescreen and has a resolution of 1280 x 800 pixels. Cover glass anti-glare treatment helps user to distinguish the screen view in extremely bright light conditions. Orientation for the display can be landscape or portrait.

The Parker Pro Display TFT-LCD screen, like any other computer screen, can have a ghost picture occur if a static image is left on the display for extended periods of time. For best viewing quality over the lifetime of the product, we recommend using the screensaver functionality.

! ***NOTICE: To avoid burn-in, use the screensaver on the display. Application development should always avoid a "static" image view whenever this is applicable and attempt to vary images whenever this is possible in application and user point of view.***

Table 15: Display type specifications

Feature	Specification
Display type	IPS TFT, Transmissive with LED backlight
Display size	10,1"
Active area	216,96 x 135,6 mm
Resolution	1280 x 800
Luminosity (Brightness)	400 cd/m2 (Typical)
Contrast ratio	800:1 (Typical)

Feature	Specification
Backlight lifetime	50 000 hours
Viewing angle, all directions	85° (Typical)
Frame rate ¹	60 Hz (Typical)
Response time ²	25 ms (Typical)

- ❗ **1) NOTICE:** *Frame rate depends on required performance in final application, this value describes more of the HW capability.*
- ❗ **2) NOTICE:** *Operating temperature can affect the display response time, especially in a cold environment. This shall be considered in application development.*

4.8. Internal features & diagnostics

4.8.1. Acceleration sensor

There is an internal 3-axis acceleration sensor with an acceleration range of ± 8 g max and sample rate of 10 Hz. This sensor can be used for example tilt sensing purposes by the application.

4.8.2. Supply supervision & voltage measurement

Pro Display has internal monitoring for a module's internal power supplies. This is implemented with a dedicated microcontroller that supervises a module's internal voltages.

It handles internal supplies for the start-up and shut-down procedures during boot-up and shutdown. Power failure mode is applied in such cases where some of the internal supplies are out of range.

4.8.3. Real time clock

This product has a real time clock (RTC) with back-up supply. The RTC is able to maintain time settings for several days. The accuracy of the RTC is better than 25 seconds / day over full operating temperature range.

Back-up supply for the RTC is a maintenance-free power source.

The RTC has a programmable alarm interrupt output for waking the product up from sleep. The interruption can be either an alarm or a specific time.

4.8.4. EEPROM

Pro Display comes with 32kB EEPROM memory. This memory is primarily intended for device production information and is available only in read-only form for the application.

4.9. Mass storage

A Micro SD-card can be attached to Pro Display to provide mass-storage capabilities for large amounts of data. This is especially good for transferring music, video clips, maps etc., that is to say, large files that may not be appropriate for storage in a module's internal memories, but in external Micro SD/Micro SDHC memory cards, due to their size.

Pro Display supports UHS-I SDR104 mode. Micro SD cards with UHS-I speed class and basic speed classes 2 to 10 and UHS-I are supported. Application and environment requirements shall be taken into account when selecting suitable Micro SD card for usage.

Table 16: Micro SD card selection guidance vs application

Application example	Minimum constant write speed	Micro SD card speed class
SD video recording	4MB/s (32Mbps)	4
Full HD video recording	6MB/s (48Mbps)	6
Full HD video recording, HD still consecutive shooting	10MB/s (80Mbps)	10
For higher potential of recording real-time broadcasts and capturing large size HD videos	10MB/s (80Mbps)	UHS - I

! *NOTICE: The average performance for read and write from / to Micro SD card is usually lower than the maximum speed. Actual performance and speed is dependent on the inner status of SD memory card as well as the use case in application.*

5. Software

5.1. General

Parker Pro Display is an apps-based product. Customer can incorporate an unlimited number of applications into one display unit. Software apps are developed with licensed software tool chain by OEM and/or 3rd party. Parker also offers some freely usable example apps, and commercial apps. For more information about our product offering, please contact your Parker Account Representative.

5.2. Parker UX Toolkit

Parker UX Toolkit includes Parker UX Platform, PC software tools and Parker Example Applications. The main PC software tool for application development is Parker Application Designer. One of the Parker Example Applications, Maintenance App, comes pre-installed in the Pro Display unit.

5.2.1. Parker UX Platform (UXP)

Parker UX Platform is a software platform for the development of human machine interface (HMI) products for mobile devices, machines and vehicles. Parker UXP is a non-real time app-based framework, and the platform is designed to enable the separation of system functionality into separate apps.

The apps will have a standard interface to UXP which will enable them to have their own life-cycle as well as an interface to exchange data with the machine and other apps. The apps can be installed and removed from the display at any time.

5.2.2. Parker Application Designer

Parker Application Designer is a programming environment that facilitates the development of graphical user interfaces. The software is based on QML language, which is designed to describe the user interface of a program. This PC tool includes a WYSIWYG (what-you-see-is-what-you-get) editor, a wide variety of ready-made modifiable UI components, data management with drag-and-drop protocol layers, language translation functions, and run-time environment for UI simulation.

! *NOTICE: For more information about Parker UX Toolkit – refer to section 1.2. - Overview of relevant documentation.*

5.3. UXP Configuration

To install any applications on a production unit of Pro Display 10, customer needs to request a specific System ID for their system from Parker.

Each machine control system needs to have own System ID. This System ID consists of a Signed System ID and version number. The System ID needs to be installed to Pro Display device. Each UXP application is certified for a certain System ID. The device refuses to install applications that are not signed by the System ID owner for the same System ID which is installed in Pro Display device. The customer needs to request their own System ID from Parker by following a process defined in the *System Certification Guide (HY33-4812-SCG/UK)*.

All production units are delivered without System ID. When the device is booted for the first time, it will allow the user to install the System ID. It is not possible to install applications before System ID is installed.

Pro Display development unit (88PROD10AD10) is intended only for development purposes. The specific open System ID is pre-installed on the development unit. It is possible to install non-certified applications on development devices. Certified applications cannot be installed on a development device.

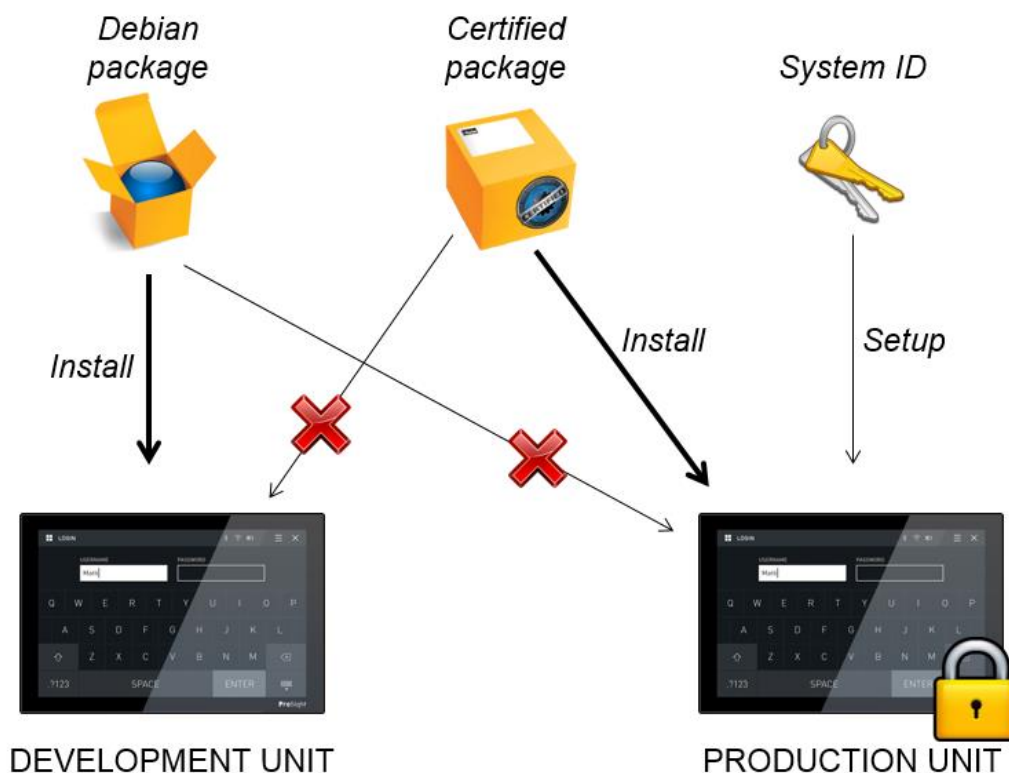

Figure 14: Installing packages – overview

5.4. Installing and removing applications

Certified packages can be installed into Parker Pro Display with the Parker Maintenance App. With this app, you can install new apps, update existing apps and remove unnecessary apps, as well as view current software versions.

It is possible for an application developer to create their own maintenance functionality with the UXP installer framework.

Primary software installation media in Pro Display is USB. Refer to chapter 2 USB for obtaining a suitable M12 to USB connection cable in order to attach the USB stick to the Pro Display unit.

5.5. Pro Display operation modes

Pro Display has three operational mode controls: **Run- shutdown-** and **sleep** mode:

- **Run mode** is started after Vbatt is in proper voltage level and ignition signal is ON.
- **Entering into sleep mode** from run mode is handled from application software.
- **Return from sleep mode** is triggered based on events from wake-up sources.
- Pro Display is **shutdown** from application software.

Table 17: Conditions for operating modes

VBatt (supply voltage)	Ignition signal	Wake-up source	Internal power supply	Operating mode
0...6V	X	X	OFF	SHUTDOWN
6...36V	ON	X	ON	RUN
6...36V	OFF	OFF	ON	SLEEP
6...36V	OFF	X	OFF	SHUTDOWN

Ignition (keylock) signal controls Pro Display power supply. Software keeps power supplies ON or forces it down. The principle of operating modes is seen in chart below:

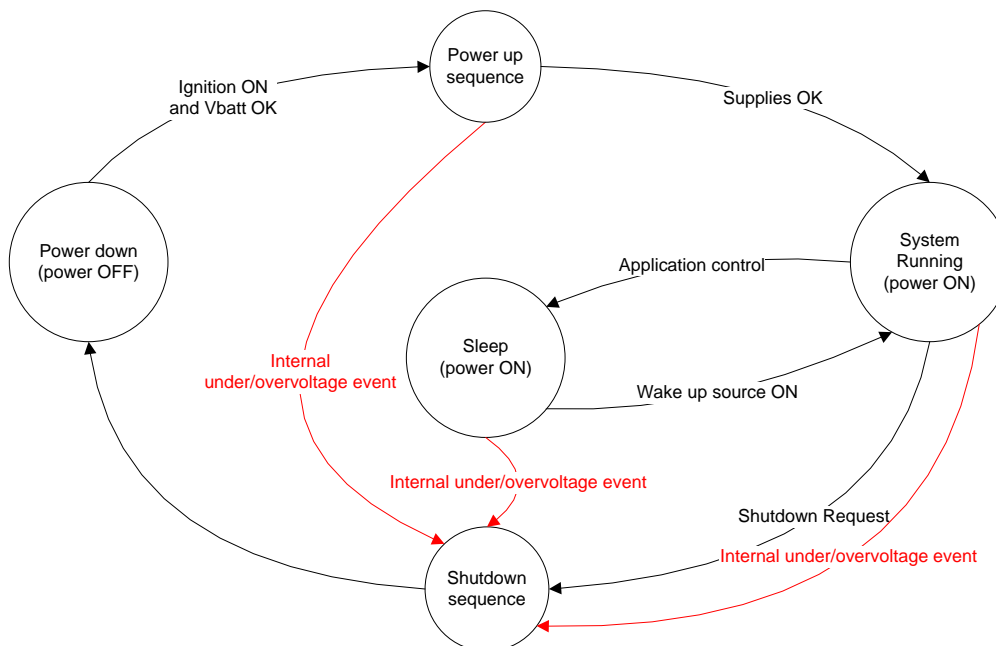

Figure 15: Pro Display operating modes

5.5.1. Sleep mode

Sleep mode is a standby-mode for the unit. Only certain module functions are in use during sleep mode. These module functions allow wake-up to normal operating mode.

Return from sleep mode can be initiated by following actions/events:

- Ignition input ON
- Wake-up input
- RTC timer expiration

5.6. Diagnostics

UXP software offers the functionality of implementing diagnostics in an application. Applications can write and read information to/from a system log.

UXP data management alarms are logged into the system log in Pro Display. The system log can be read with Maintenance App.

6. Mechanics

6.1. Mechanical construction

The Pro Display unit mechanics consist of a die cast aluminium back cover, PC-ABS front frame and physically strengthened cover glass with anti-glare coating.



Figure 16: Pro Display 10, front and rear view.

6.2. Dimensional drawing

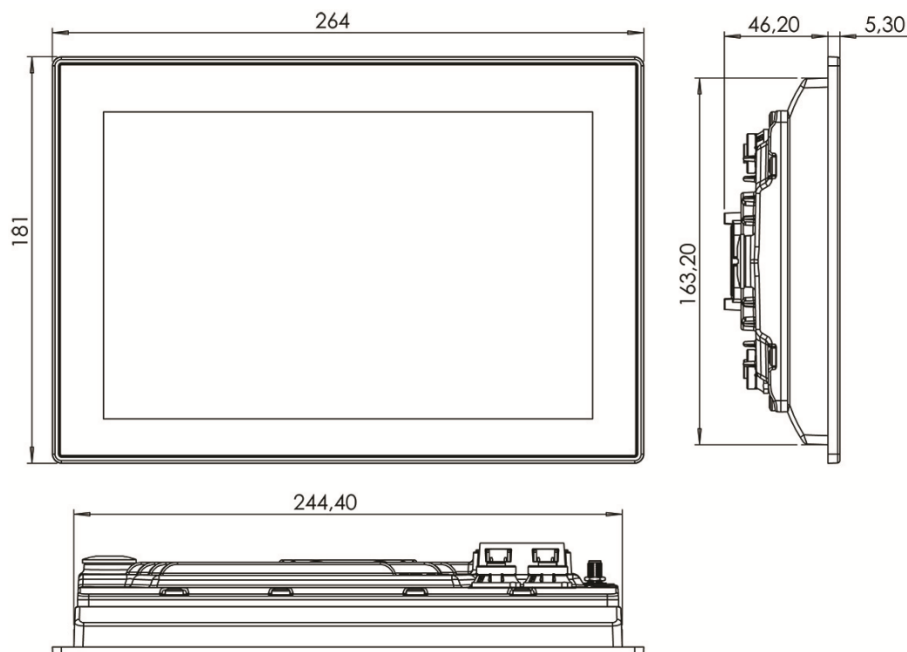

Figure 17: Pro Display 10 dimensions

7. Mounting

7.1. Mounting the module

Pro Display has two alternative mounting methods that are presented on next chapters:

- Panel mounting
- Swivel mount (RAM ball)

7.1.1. Assembly surface considerations

Mount the device on to a smooth and flat surface. Device fastening to an uneven surface will stress the enclosure or damage the outer flange. Fastening on a rough or uneven surface will affect the sealing.

7.2. Dashboard or panel assembly

7.2.1. Panel assembly

Pro Display 10 can be assembled to vehicle dashboard, to separate panel in vehicle cabin, or for example to cabinet door in installations where exists separate electrification cabinet. Currently Pro Display 10 has no dedicated panel mounting kits available due to the fact that the panel thickness can vary depending on assembly surface and customer needs.

Following guidelines shall be taking into consideration in such case that Pro Display 10 will be mounted to panel or dashboard:

- A. Use gasket between device flange and panel cut-out edges to ensure adequate sealing for the installation location and prevent device to vibrate in assembly location during operation.
- B. Prepare and attach electrical connections to Pro Display 10 before closing the cut-out with the device. Take into account the module mounting depth 46,2 mm + needed space for connectors installation behind the Pro Display 10.
- C. Place the device to panel cutout and push the device lightly / ensure its stability to panel cutout edge.
- D. Consider suitable support points for the possible bracket / fixing device in the backside of the installation panel to get the device to settle down evenly into the panel installation cut-out
- E. Fasten mounting bracket with screws from the backside of the assembly surface- use four mounting points in Pro Display 10 device to fix your bracket. Note the guidelines for screw lengthness below:
 - a. Use only existing mounting points of Pro Display 10 to fix the unit for example with separate fixing bracket to panel
 - b. The mounting points are blind holes with a maximum thread depth of 7,5 mm
 - c. If the spacer is not used the screw length should be 6 mm. *

d. Apply tightening torque 2,7 Nm.

 ***) NOTICE: Longer screws may damage the device when tightened!**

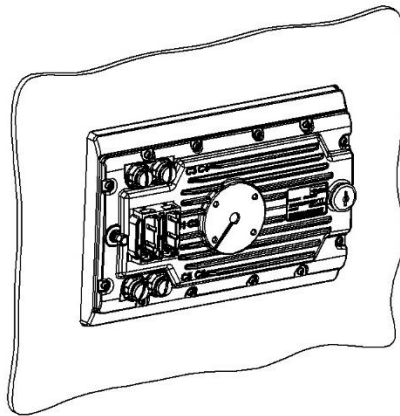

Figure 18: Pro Display 10 panel mount method. This assembly is intended for assemblies where the installer can operate behind the assembly surface – for example cabinet doors.

Cutout dimensioning for Pro Display 10 panel mounting on vehicle

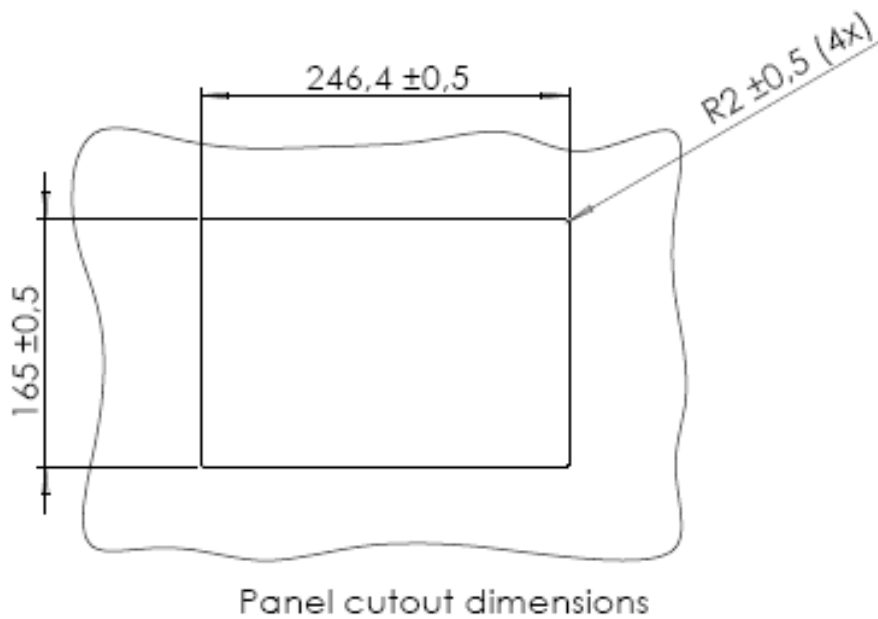

Figure 19: Cutout dimensioning for panel mounting.

7.3. Ball / swivel mount

Swivel mounting for Pro Display is achieved by using the RAM® ball mount accessory. The benefit of this installation method is the possibility to adjust the display angle after assembly simply by loosening and again tightening the wing nut in the swivel arm. This mounting method for Pro Display is presented below.

With Pro Display 10, Parker recommends using 1" (2 x RAM-B-202U, 1 x RAM-B-201U) or 1,5" (2 x RAM-202U, 1 x RAM-201U) RAM ball mount. To fasten the RAM 2,5" round plate, use 4 x M4 screws of class 8.8 or higher. It is preferred to use Hex Socket Cap Screw ISO 4762 / DIN 912 or Pan Head Torx Machine Screw ISO 14583 TX / DIN 7985 type.

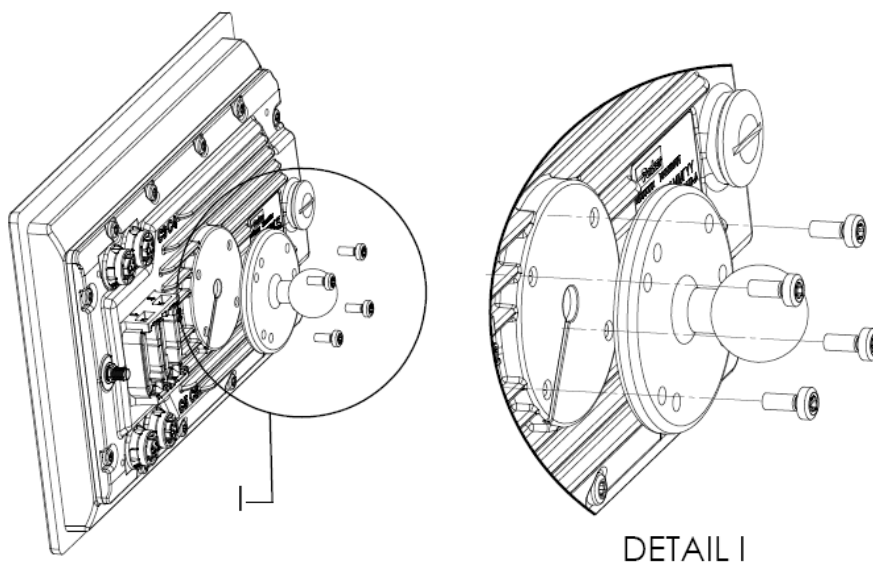

Figure 20: Pro Display 10 swivel mount method using RAM ball. First RAM ball is installed into rear side of the Pro Display and the second RAM ball into assembly surface of the vehicle.

- A. Attach the RAM ball into the rear side of the Pro Display and fasten it with 4 pcs of M4 screws. Apply a torque of about **2,7** Nm.
- B. Fix swivel arm loosely to RAM ball just attached into Pro display
- C. Attach the RAM ball into vehicle's assembly surface and fasten it with 4 pcs of M4 screws, using tightening torque of about **2,7** Nm.
- D. Take Pro Display and proceed with electrical connections of vehicle wire harness plugs into Pro Display connector receptacles.
- E. Take the swivel arm and loosen the wing nut in the middle so that you can attach it first loosely into RAM ball in the back side of the Pro Display.
- F. Place Pro Display near the RAM ball in the vehicle assembly surface and start to adapt swivel arm open end into that. Loose the wing nut in the middle of the swivel arm until the arm open end goes around the RAM ball in the vehicle side.
- G. Start to tighten the wing nut at the same time you still hold the Pro Display with your other hand.
- H. Find most suitable angle for the Pro Display in the vehicle

- I. Finish the wing nut tightening when Pro Display is mounted into suitable viewing angle in the vehicle
- J. Ensure that Pro Display is locked into its final mounting position by trying to move it gently. When there is no noticeable movement detected the installation is adequate. Otherwise continue tightening of wing nut to obtain the stable position for the display.

A



B



Figure 21: Figure A - RAM ball installed into rear side of Pro Display. Figure B - Swivel mounting accessory attached into Pro Display before final install into vehicle.

8. Installation

8.1. Electrical connections

All electrical connections are located on the rear side of the Pro Display unit. The following chapters present available connections.

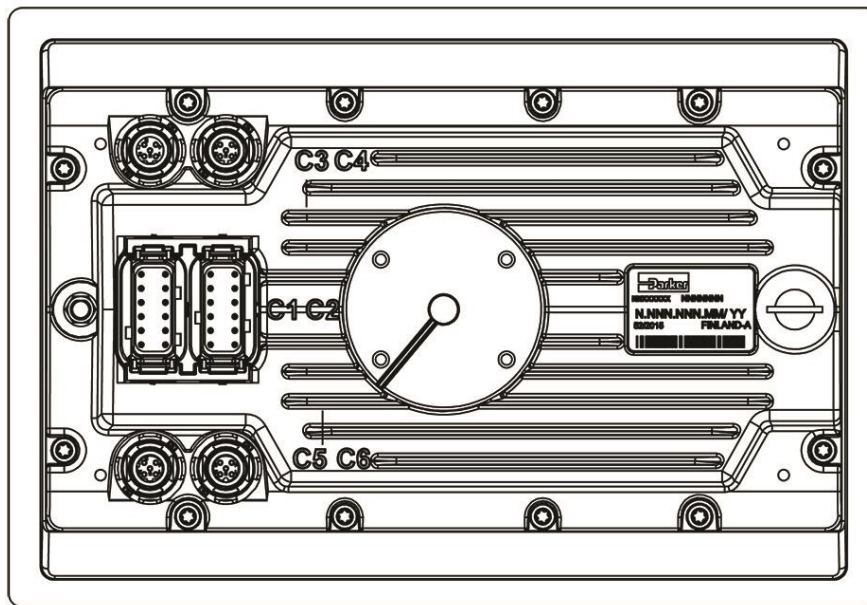

Figure 22: Pro Display back cover with connectors

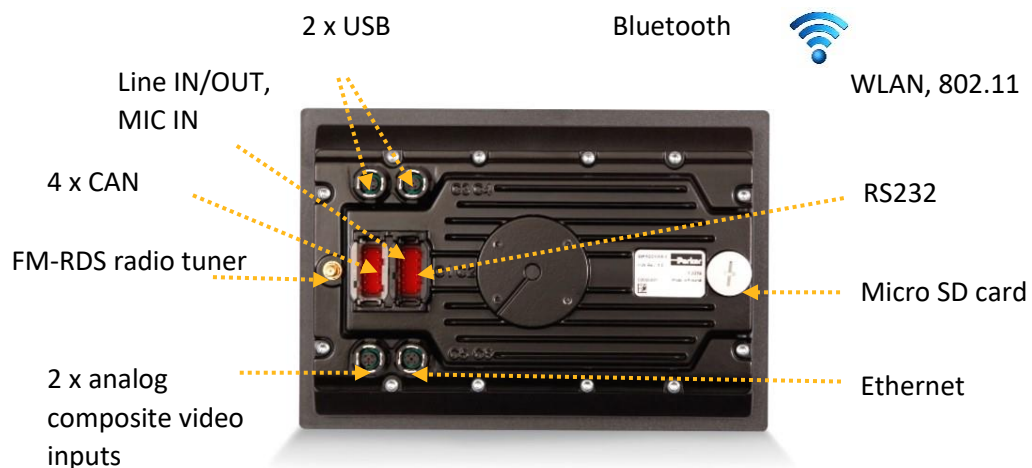

Figure 23: Pro Display interfaces

8.1.1. Main connectors C1 and C2

C1 and C2 are the main connectors of the unit and consist of power supply connections, CAN & RS232 communication interfaces, audio interfaces as well as voltage inputs and the high side output of the device. Pin carrier type for these connectors is DTM04-12P, Deutsch item 61135-21.

Table 18: Connector C1 pin assignment on Pro Display module

Pin	Name	Function
C1:1	GND	Supply voltage ground
C1:2	CAN1_L	CAN Channel 1 / Low signal
C1:3	CAN2_L	CAN Channel 2 / Low signal
C1:4	CAN3_L	CAN Channel 3 / Low signal
C1:5	CAN4_L	CAN Channel 4 / Low signal
C1:6	IGNITION	Ignition (Keylock) input
C1:7	WAKE-UP	Wakes up the device from sleep mode
C1:8	CAN4_H	CAN Channel 4 / High signal
C1:9	CAN3_H	CAN Channel 3 / High signal
C1:10	CAN2_H	CAN Channel 2 / High signal
C1:11	CAN1_H	CAN Channel 1 / High signal
C1:12	VBATT	Supply voltage input +

Table 19: Connector C2 pin assignment

Pin	Name	Function
C2:1	RS232_RXD_2	RS232 Receive
C2:2	RS232_TXD_2	RS232 Transmit
C2:3	GND	RS232 ground
C2:4	AUDIO_LINE_OUT_L	Audio Line Output, left channel
C2:5	AUDIO_LINE_OUT_R	Audio Line Output, right channel
C2:6	GND	Audio ground
C2:7	HSIDE_OUT	High Side output
C2:8	AUDIO_LINE_IN_R	Audio Line Input, right channel
C2:9	AUDIO_LINE_IN_L	Audio Line Input, left channel
C2:10	MIC_N	Microphone input signal -
C2:11	MIC_P	Microphone input signal +
C2:12	MIC_BIAS	Microphone bias

Corresponding mating connector types for C1 and C2 are presented in following table.

Table 20: C1 and C2 Mating connector type to interface the Pro Display into system

Conn.	Key	Housing	Pin type	Wedge type	Sealing plug	Recomm. Cable
C1	A	Deutsch DTM06- 12SA	Deutsch 1062-20-0222	Deutsch WM12S	Deutsch 0413-204-2005	0,75...1,0 mm ² (AWG 18)
C2	B	Deutsch DTM06- 12SB				

Prototype installation cables and connector kit are available from Parker – see Appendix C for ordering codes.

! NOTICE

No pin may be "double crimped". This means that only one wire may be attached to any given pin. Failure to follow this instruction will cause the module to fail to meet the environmental specification. Make "Y" connections or splices using weatherproof methods external to the Pro Display connectors.

! NOTICE

It is recommended to twist following wires in the harness to reduce possible electromagnetic interference from environment:

- *audio line in & audio ground*
- *line out & audio ground*
- *microphone in & bias*
- *CAN1*
- *CAN2*
- *CAN3*
- *CAN4*

8.1.2. USB connections C3 and C4

Connector C3 and C4 provides USB connections to/from the Pro Display unit. Connector type: M12, 4-pin D-coded Industrial Ethernet connector.

Phoenix Contact's type for C3 and C4 - M12 connector on Pro Display: SACC-CI-M12FSD-4CON-SH TOR 32 – 1457636. Related housing screw connection type is: SACC-BP-F-M12/VAR-2,4/3,2-9TIP-1414233.

Table 21: Connector C3 (USB 1-device) pin assignment

Pin	Name	Function
C3:1	5V_USB1	USB1 power supply output
C3:2	USB1-	USB1 -signal
C3:3	USB1+	USB1 +signal
C3:4	GND	Ground
C3:5	SHIELD	Cable shield connection

Table 22: Connector C4 (USB 0 -device) pin assignment

Pin	Name	Function
C4:1	5V_USB0	USB0 power supply output
C4:2	USB0-	USB0 -signal
C4:3	USB0+	USB0 +signal
C4:4	GND	Ground
C4:5	SHIELD	Cable shield connection



Figure 24: USB Connectors C3 & C4 on the backside of the module

Suitable “M12 male D-coded 4pin”- mating connector types are available from several manufacturers. See **Error! Reference source not found.** in section 8.1.4. as example of mating connector types for C3 and C4.

8.1.3. Video connection C5

Connector C5 Provides Composite video signal connections to Pro Display unit and 12V power out for external analogue video cameras.

Table 23: Connector C5 (Video) pin assignment

Pin	Name	Function
C5:1	CVBS_IN1	Video Input 1
C5:2	12V_CAM	Power supply output for Video camera (+12V)
C5:3	GND	Camera Supply ground (0V)
C5:4	CVBS_IN2	Video Input 2
C5:5	GND	Video ground
C5:6	SHIELD	Cable shield connection



Figure 25: Video input & Ethernet connections

Table 24: C5 Mating connector type to interface the Pro Display into system

Connector type	Conn.	Key	Part number	Conn. type	Recommended Cable
Harting M12-L Male, unshielded	C5	A	Harting: 21 03 272 1505	Straight	
Harting M12-L Male Crimp, angled	C5	A	Harting: 21 03 822 3505	Angled	

Suitable “M12 male A-coded 5pin”- connectors are also available from several other manufacturers.

8.1.4. Ethernet connection C6

Connector C6 Provides 10/100Mbps Ethernet interface for Pro Display unit.

Table 25: Connector C6 (Ethernet) pin assignment

Pin	Name	Function
C6:1	TX+	Transmit, data+
C6:2	RX+	Receive, data+
C6:3	TX-	Transmit, data-
C6:4	RX-	Receive, data-
C6:5	SHIELD	Cable shield connection

Table 26: C3, C4 and C6 Mating connector type to interface Pro Display into system

Connector type	Conn.	Key	Part number	Conn. type	Recommended Cable
Hirschmann EM12S Octopus Weidmuller SAISM-4/8S-M12-4P D-COD Harting Harax M12L Male, 4 poles, D-coding	C3, C4, C6	D	Hirschmann 934 445-001 Weidmuller 1892120000 Harting: 21 03 281 1405 21 03 881 1405	Straight	Conn. C3, C4: USB 2.0 cable, outer \varnothing 6...8 mm Conn. C6: Cat 5e, 4 x 0,22mm ² (AWG24)
Harting M12 Crimp, shielded, Male, 4 poles, D-coding, angled	C3, C4, C6	D	Harting: 21 03 882 3405	Angled	

Suitable “M12 male D-coded 4pin”- connectors are also available from several other manufacturers.

Ethernet cable is available from Parker – see Appendix C for ordering codes.

8.1.5. Micro SD card interface

Micro SD is possible to use as mass storage of media with Pro Display. This connection is sealed with a cover plug on the rear side of the unit to maintain the ingress protection (IP) rating of the module.

The Pro Display Micro SD card interface is compliant with SD command/response sets and a physical layer as defined in the SD Memory Card Specifications, v3.0 including high-capacity SDHC cards up to 32GB.

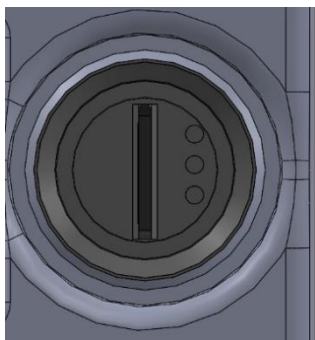



[Header Link to Contents](#)

Figure 26: The Micro SD card slot in the rear side of the Pro Display unit. This slot shall be always protected with a cover plug that is part of the Pro Display unit assembly.

Procedure for installing the Micro SD/ Micro SDHC card to Pro Display:

- A. Remove the cover plug. You may need a small coin or preferably a screwdriver with a size 3 standard head for opening this cover.
- B. Place the Micro SD card into the slot as presented in figure B (the contacts are towards the product label).
- C. Push the Micro SD card evenly into the card slot, figure C.
- D. Continue pressing the Micro SD card until it has set on its bottom position, figure D.
- E. Secure the Micro SD card slot with cover plug. Tighten the plug lightly with small coin or screwdriver to prevent it loosening during operation.

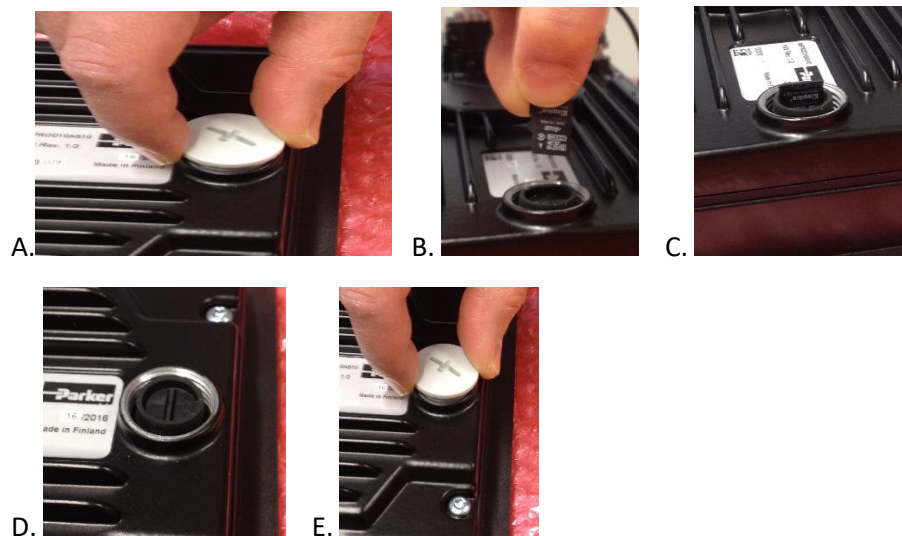

Figure 27 (subfigures A to E): Micro SD card installation into connection C1 on the rear side of the Pro Display

Removal procedure happens in backwards order and the Micro SD card shall be pulled to get it out as there is no spring action in this connection.

NOTICE:

Micro SD card is not included to Parker Pro Display unit delivery.

Warning! Risk of damage to equipment or degradation of signal.

User must always close the Micro SD card connection with cover plug to maintain the unit IP rating and functionality. Parker do not take any responsibility if cover plug is not properly placed back into unit after accessing to Micro SD connection.

Warning! Risk of damage to equipment or degradation of signal.

Be careful to place the Micro SD card into its place correctly (see figures B, C & D) before closing the cover screw part.

8.1.6. Radio antenna connection

Table 27: Radio antenna interface

Pin	Name	Function
1	GND	Ground (chassis of the connector)
2	AERIAL	Antenna signal (centre pin)

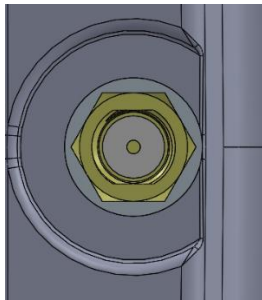

Figure 28: Radio antenna connection on the rear side of the Pro Display

Table 28: Mating connector types for Radio antenna connection

Connector	Part number	Conn. type	Recomm. Cable
Male SMA Crimp Plug connector	Amphenol: SMA1111A1-3GT50G-1-50	Straight	Normal cable
	Amphenol: SMA1111A2-3GT50G-5-50	Straight	Miniature cable
SMA R/A Plug connector	Amphenol: SMA1142C2-3GT50G-1-50	Angled	Normal cable
	Amphenol: SMA1142C1-3GT50G-5-50	Angled	Miniature cable

Suitable “SMA male”- connectors are also available from several other manufacturers. Impedance 50 Ohm.

! *NOTICE: Used cable type in customer application needs to be checked before selecting SMA plug connector as the connector plugs are available for many different cable types. “Table 28: Mating connector types” provides examples from one possible manufacturer.*

8.2. Power supply considerations

8.2.1. Supply voltage

Before any installation of the system can take place, make sure that the ignition lock of the vehicle is turned off and that the battery is disconnected.

8.2.2. Emergency stop

Make sure that an Emergency Stop switch disconnecting the power supply, is easily accessible at any time. The figure below shows how to connect the emergency stop.

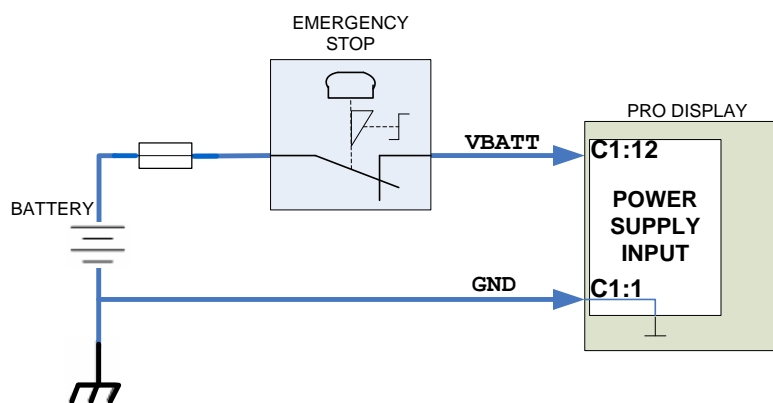

Figure 29: Emergency stop connection principle

✘ **Danger! Risk of injury.**

The emergency stop must disconnect the power supply to the module; do not connect the emergency stop as a signal input only. The emergency stop must be installed so that the risk of module reverse feed is avoided.

8.2.3. Connecting of supply voltage

The supply voltage should be within the specified operating voltage range, see Appendix A. Connect the supply voltage to VBatt and GND. Protect the module by using a fuse. For recommended fuse rating, see Appendix A.

8.2.4. RTC back-up supply

The Pro Display module has a clock that is used for date/time stamping when logging data. The real time clock back-up power supply is based on a super capacitor. (There is no separate power supply input for RTC). Back-up supply gets charged from the module power supply.

❗ **NOTICE:** *If the customer application is relying on RTC functionality, then RTC back-up supply maximum operating times shall be taken into account during application development.*



8.2.5. Polarity reversal

The module is protected against power supply polarity reversal and over-voltage, provided an external fuse is being used.

- ⚠ Warning! Risk of damage to equipment or degradation of signal**
If this fuse is not used, polarity reversal can damage the unit.

9. Start-up

9.1. Procedures with software

Initializing Pro Display, serial products (88PROD10AS10):

- A. Insert USB stick with the system ID file and certified application packages.
- B. Turn on the Pro Display.
- C. The system will boot and install the new System ID and application packages from the USB stick.
- D. When the installation is completed, the setup application is removed and the system restarts.

Pro Display, development units (88PROD10AD10):

- Application packages can be installed using the Maintenance App.
- When the development unit is booted up, the Maintenance App starts automatically.

10. Appendix A – Technical summary

This chapter and the tables below present a technical summary of the Parker Pro Display 10 product:

Table 29: Electrical Ratings & EMC

Feature	Rating / Value
Operating temperature	-30 to +70 °C
Storage temperature	-40 to +85 °C
Voltage supply on VBatt	6 to 36VDC
Voltage on any pin with respect to GND	36V
Reverse polarity protection on VBatt with respect to GND	-36V with external 20A fuse (recommended fuse 10A)
Electrical Environment	ISO15003 and ISO16750-2
EMC	ISO13766 and ISO14982
Certification	CE, E-Mark R10-050108

Table 30: Mechanical & environmental ratings

Feature	Rating / Value
Mechanical / climate environment	ISO16750-4
Dimensions	264 x 181 x 52 mm (width, height, depth)
Case material	Front Cover: PC-ABS Back Cover: Die casted Aluminium Cover glass on front side: Hardened glass
Dust/Water Ingress Protection	IP65
Weight	1,42 kg

Table 31: System ratings – Pro Display 10 Advanced & Development variants

Feature	Rating / Value
CPU	Freescale iMX6, Cortex A9 Dual core @ 800MHz
RAM	1GB
Internal FLASH	2GB eMMC
External memory	up to 32GB with Micro SD / Micro SDHC card *

Feature	Rating / Value
Communication	<ul style="list-style-type: none"> • 1 x Ethernet 10 or 100 Mbps speed • 4 x CAN • 2 x USB 2.0 • 1 x RS232 • 1 x Bluetooth • 1 x WLAN
Video inputs	2 x composite video inputs (CVBS_IN_1, CVBS_IN_2) with NTSC/PAL/SECAM autodetection.
Audio	<ul style="list-style-type: none"> • Stereo Line-in & Line-out • 5 Selectable audio sources: <ul style="list-style-type: none"> • Bluetooth audio • Audio line input (selectable with FM radio) • FM radio (selectable with audio line input) • Microphone input • Digital audio from module • 2 Selectable Audio outputs: <ul style="list-style-type: none"> • Audio line output (to external amplifier) • Digital audio to module (record)
I/O	<ul style="list-style-type: none"> • Digital/ Voltage inputs: <ul style="list-style-type: none"> • 1 x Ignition (keylock) input • 1 x Wake-up input • Outputs <ul style="list-style-type: none"> • 1 x High side output: Vbatt / 200mA max • 1 x Camera supply output 12V / 1A max
Internal features	<ul style="list-style-type: none"> • 3-axis acceleration sensor • Supply supervision / internal voltage measurement • Real Time Clock (maintain time settings for 4 days over storage temperature range, and 9 days in +25C)
Human - Machine Interface	<ul style="list-style-type: none"> • Display <ul style="list-style-type: none"> • TFT Transmissive with LED backlight • Size: 10,1" • Active area: 216,96 x 135,6 mm • Resolution: 1280 x 800 • Luminosity / Brightness: 400 cd/m2 (Typical) • Contrast ratio: 800:1 (Typical) • Touchpanel <ul style="list-style-type: none"> • Type: PCAP (Projected Capacitive Touchscreen) • Sensor active area: 218,96 x 137,6 mm • One-touch and Multi-finger support • Hardened cover glass with anti-glare coating

! *) **NOTICE: Micro SD/ Micro SDHC card is not included into Pro Display 10 delivery.**



[Header Link to Contents](#)

11. Appendix B – Environmental summary

Table 32: Environmental Protection - Climate environment ISO 16750-4

Test Description	Specification	Test level/ Rating
Temperature shock	IEC 60068-2-14, test Na	<ul style="list-style-type: none"> • Min temp: -40 °C • Max temp: +85 °C • Exposure time at each extreme: 40 min • Number of cycles: 100
High temperature, storage	IEC 60068-2-2, test B	<ul style="list-style-type: none"> • Temperature: +85 °C • Time: 96 h
Low temperature, storage	IEC 60068-2-1, test A	<ul style="list-style-type: none"> • Temperature: -40 °C • Time: 96 h
Damp heat	IEC 60068-2-78	<ul style="list-style-type: none"> • Temperature: +40 °C • Test humidity: 93 % RH • Test time: 21 days
Damp heat cyclic	IEC 60068-2-30	<ul style="list-style-type: none"> • (12 h + 12 h cycle) • Temp.min: 25 °C • Temp.max: 55 °C • Cycles: 6 • Test humidity: 95 % RH
Temperature cycling	IEC 60068-2-14, test Nb ISO 16750-4	<ul style="list-style-type: none"> • Temp.min: -30 °C • Temp.max: +70 °C • Cycles: 30 • Cycle time: 8 h
High temperature, operational	IEC 60068-2-2, test B	<ul style="list-style-type: none"> • Temperature: +70 °C • Time: 96 h
Low temperature, operational	IEC 60068-2-1, test A	<ul style="list-style-type: none"> • Temperature: -30 °C • Time: 96 h

Table 33: Environmental Protection – Mechanical environment

Test Description	Specification	Test level/ Rating
Sinusoidal vibration	IEC 60068-2-6	<ul style="list-style-type: none"> • Freq. range: 5...500 Hz • 3 directions • Freq. Cycles: 20
Random vibration	IEC 60068-2-64 Test Fh / ISO 16750-3	<ul style="list-style-type: none"> • Test duration: 32 h in each axis • Test all mutual perpendicular axis
Mechanical shock	IEC 60068-2-27	<ul style="list-style-type: none"> • Acceleration: 500 m/s² • 10 shocks in all 3 axes in both directions
Bump	EN 60068-2-29	<ul style="list-style-type: none"> • Acceleration: 400 m/s² • Duration: 6 ms • 100 shocks x 3 axes
Resonance search	IEC 60068-2-6	<ul style="list-style-type: none"> • 5mins at resonant points • Frequency range (Hz): 10 to 2000 • Acceleration: 5 g
Impact	Parker	<ul style="list-style-type: none"> • Test weight: 50 grams • Height: 0,4 m
Free fall	ISO 16750-3, 4.3 / IEC 60068-2-32	<ul style="list-style-type: none"> • Height: 1 m • No hidden failures after the test

Table 34: ESD, IP, Atmosphere, corrosion endurance, readability

Test Description	Specification	Test level/ Rating
Electrostatic discharge operation	ISO 10605	<ul style="list-style-type: none"> • IV • 8kV contact and 15kV air.
Electrostatic discharge handling	ISO 10605	<ul style="list-style-type: none"> • IV • 8kV contact and 15kV air.
Ingress protection IP65 Dust Ingress	IEC 60529	<ul style="list-style-type: none"> • Category 1 • IP6X
Ingress protection IP65 Water Ingress	IEC 60529	<ul style="list-style-type: none"> • IPX5
Salt mist	EN 60068-2-52 Test Kb	<ul style="list-style-type: none"> • Severity: 2 • Test time: 72 hours
Chemical brush exposure	ISO 15003	<ul style="list-style-type: none"> • Temperature: 25 °C • Test humidity: 50 % RH • Test time: 100 h Chemicals: <ul style="list-style-type: none"> • Urea nitrogen saturated solution • Liquid lime 10 % • NPK fertilizer (7,5 % N, 7.5 % P, 7.5 % K) saturated solution • Ammonium hydroxide 20 % aqueous solution • Diesel fuel 100 % • Petrol 100 % • Hydraulic oil 100 % • Ethylene glycol 50 % aqueous solution • Engine oil 100 % • Calcium chloride
Solar radiation	EN 60068-2-5	<ul style="list-style-type: none"> • Temperature: +40 °C • Exposure time: 10 d • UV radiation wavelength: 280 nm...400 nm
Readability	EP 455	

Table 35: Environmental Protection – Electrical

Test Description	Specification	Test level/ Rating
Operation voltage	ISO 16750-2	<ul style="list-style-type: none"> • 6V...16V (12V systems) • 10V...32V (24V systems)
Overvoltage	ISO 15003	<ul style="list-style-type: none"> • Test level: 48V • Test time: 1 min / 5 min
Superimposed alternating voltage	ISO 16750-2	<ul style="list-style-type: none"> • Test voltages U_{max}: 16V and 32V • Test severity: 2 (U_{pp}: 4V) • Test frequency: 50 Hz – 20 kHz • Frequency sweep: Triangular, linear • Sweep duration: 120 s • Number of sweeps: 5
Reversed voltage	SAE J1455	<ul style="list-style-type: none"> • Test level UA: -36V (24V system). • Test level UA: -24V (12V system). • Duration: 5 min.
Slow decrease and increase of supply voltage	ISO 16750-2	<ul style="list-style-type: none"> • Supply voltage range: 8 to 36V. • Decrease the supply voltage from U_{max} to 0V and then increase it from 0V to U_{max} • Change rate: 0,5 ±0,1 V/min.
Momentary drop on supply voltage	ISO 16750-2	<ul style="list-style-type: none"> • Supply voltage U_{min}: 8V • Voltage drop to 4,5V for 100 ms • Rise/fall time: 10 ms
Reset behaviour at voltage drop	ISO 16750-2	
Line interruption (single & multiple line interruption)	ISO 16750-2	<ul style="list-style-type: none"> • Interruption time: 10 s • Oper.voltage UA: 28V.
Short circuit protection (signal & load circuits)	ISO 16750-2	<ul style="list-style-type: none"> • 60 s / 5 min
Power supply with and without battery	Parker	
Immunity to micro power cuts	Parker	<ul style="list-style-type: none"> • U_{nom}: 13,5V and 27V • Transit.app: 10 μs • Cut durations: 100, 200 and 400 μs • Test duration: 5 pulses for each level • Pulse period > 1 s

Table 36: Electromagnetic compatibility

Test Description	Specification	Test level/ Rating
Conducted transient emission	ISO 7637-2	• III
Radiated RF emission	CISPR 25 ed3.0	• III
Radiated RF susceptibility	ISO 11452-1, ISO 11452-2	• IV
Immunity to low-frequency magnetic fields	ISO 11452-8	• IV
Conducted RF emission	CISPR 25 ed3.0	• III
Conducted susceptibility	ISO 11452-1, ISO 11452-4	• IV
Transient - inductive load switching, inductance, coupling, cranking, load dump	ISO 7637-2	<ul style="list-style-type: none"> • Pulse 1: III (12 & 24V) • Pulse 2a: III (12 & 24V) • Pulse 2b: IV (12 & 24V) • Pulse 3a: III (12 & 24V) • Pulse 3b: III (12 & 24V) • Pulse 4: III / IV (12 & 24V) • Pulse 5a: III, UA: 27V; Us: 123V;
Transient, signal lines, fast	ISO 7637-3	• IV

12. Appendix C - Ordering codes

Pro Display 10 is available in two variants, as described in Table 37: Pro Display 10 product variants”, which defines the main specifications for the units. Available accessories for the product are presented in “Table 38: Pro Display accessories”.

Table 37: Pro Display 10 product variants

Item	Description
88PROD10AS10	Pro Display 10 Advanced with Infotainment features - iMX6 Dual core, 1GB RAM & 2GB Flash memory.
88PROD10AIS10	Pro Display 10 Advanced with Infotainment features - iMX6 Dual core, 1GB RAM & 2GB Flash memory, + ISOBUS SUITE software installed.
88PROD10AD10	Pro Display 10 Development unit with full feature set (similar to Advanced version). Only for development use.

Table 38: Pro Display accessories

Item	Description
88CABPRODUSB	USB Cable, Pro Display (e.g. for installing software)
88CABPRODDHK	Development harness kit for Pro Display, for product development and table testing. C1 & C2 main connector harness equipped with most common communication and audio interface connectors.
Compatible IQAN Accessories:	
20077780	Ethernet Cable M12 to RJ45, 1,5 meters
20077785	Panel mount Ethernet adapter cable, 1,5 meters
5030125	Prototype installation cables, DTM06-12 / Main Connector C1
5030126	Prototype installation cables, DTM06-12 / Main Connector C2
20073081	Connector kit, Main Connectors C1 & C2 / DTM12 (connectors only)
20085106	IQAN-SV Ethernet (IP) camera