

CV	Check Valves
SH	Shuttle Valves
LM	Load/Motor Controls
FC	Flow Controls
PC	Pressure Controls
LE	Logic Elements
DC	Directional Controls
MV	Manual Valves
SV	Solenoid Valves
PV	Proportional Valves
CE	Coils & Electronics
CB	Cartpak Bodies
BC	Bodies & Cavities
TD	Technical Data

General Description

4-Way, 3 Position, Open Center Spool Valve.
 For additional information see Technical Tips on pages SV1-SV5.

Features

- Designed to operate double acting cylinders, pilot circuits and bi-directional motors, etc.
- High flow capacity with reduced space requirements
- High pressure capability
- One piece cartridge housing ensures internal concentricity
- Coil: Waterproof, hermetically sealed, requires no O'Rings; Symmetrical coil can be reversed without affecting performance.
- Manual override available

Specifications

Rated Flow	13 LPM (3.5 GPM)
Maximum Inlet Pressure	350 Bar (5000 PSI)
Maximum Tank Pressure	210 Bar (3000 PSI)
Cartridge Material	All parts steel. All operating parts hardened steel.
Operating Temp. Range/Seals	-34°C to +121°C (Nitrile) (-30°F to +250°F) -26°C to +204°C (Fluorocarbon) (-15°F to +400°F)
Fluid Compatibility/Viscosity	Mineral-based or synthetic with lubricating properties at viscosities of 45 to 2000 SSU (6 to 420 cSt)
Filtration	ISO 4406 18/16/13, SAE Class 4
Approx. Weight	.18 kg (.40 lbs.)
Cavity	C08-4 (See BC Section for more details)

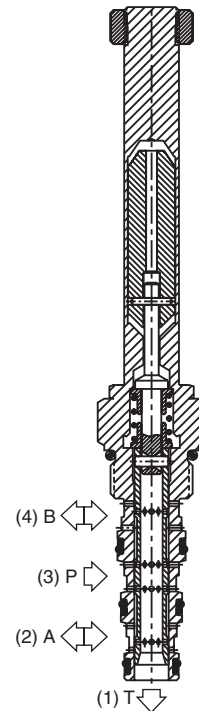
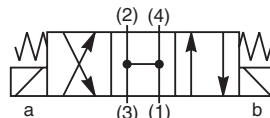

Performance Curves

Pressure Drop vs. Flow (Through cartridge only)

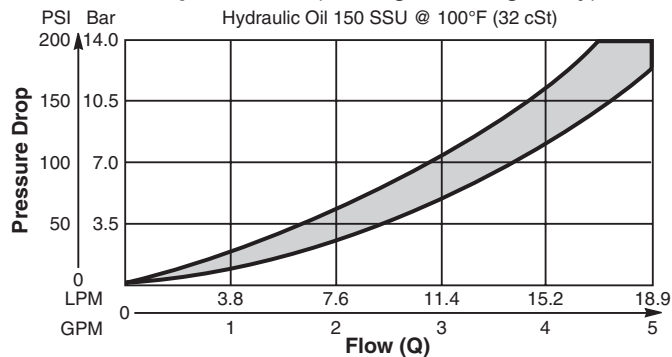

Operating Limits (Measured at 75% of Nominal Current)

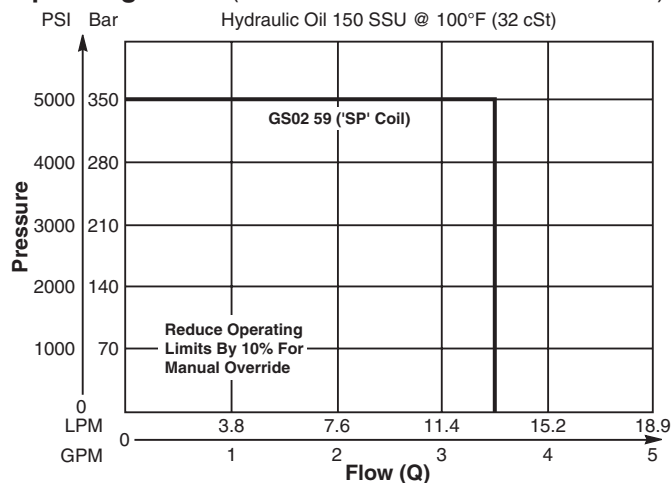

Dimensions Millimeters (Inches)

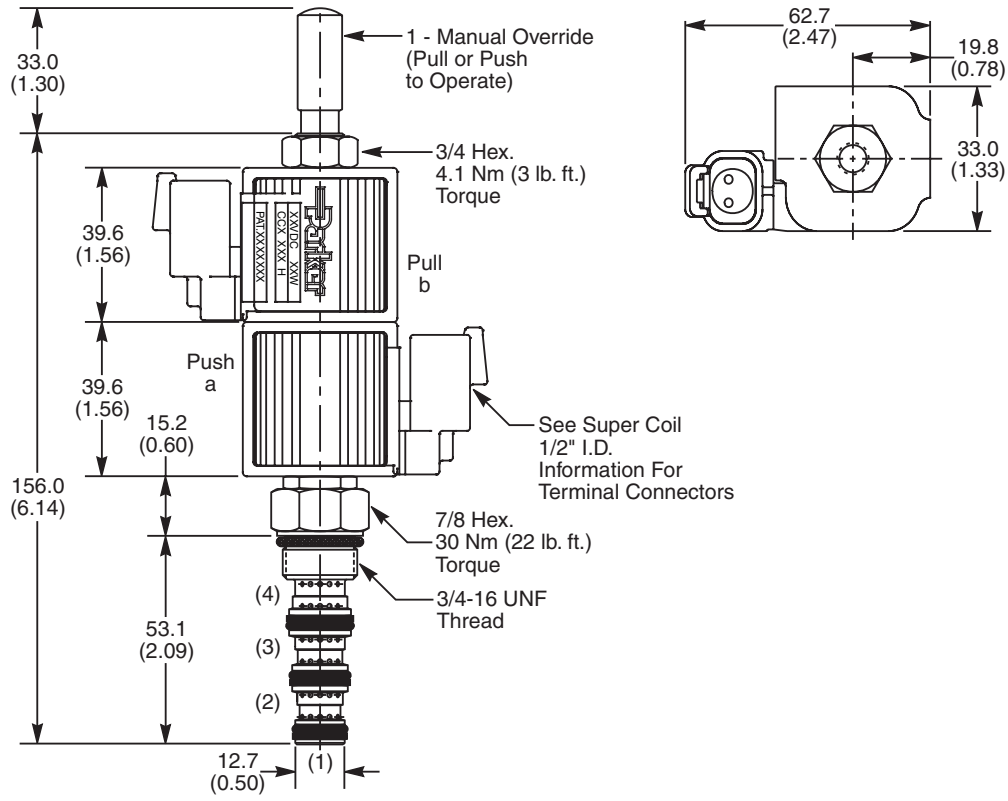

Ordering Information

GS02	59		0	
08 Size Solenoid Valve	Style	Override Option	Screen	Seals

Highlighted represents preferred options that offer the shortest lead times. Other options may be available, but at extended lead times.

Coil(s) sold separately. Please see section CE of this catalog, 1/2" Super-Coil (CC series), for ordering information.

Code	Style
59	High Flow ('SP' Coil)

Code	Screen
0	Not Available

Code	Override Options
0	None
1	Manual Override
2	Detented M.O.

Code	Seals / Kit No.
N	Nitrile / Buna-N (Std.) (SK30078N-1)
V	Fluorocarbon / (SK30078V-1)

Order Bodies Separately
 See section BC

B08	4	
08 size	4-Way Cavity	Port Size

Code	Port Size / Body Material
6T	SAE-6 / Steel (5000 PSI)
A6T	SAE-6 / Aluminium (3000 PSI)

- CV Check Valves
- SH Shuttle Valves
- LM Load/Motor Controls
- FC Flow Controls
- PC Pressure Controls
- LE Logic Elements
- DC Directional Controls
- MV Manual Valves
- SV Solenoid Valves
- PV Proportional Valves
- CE Coils & Electronics
- CB Carpak Bodies
- BC Bodies & Cavities
- TD Technical Data