

CV	Check Valves
SH	Shuttle Valves
LM	Load/Motor Controls
FC	Flow Controls
PC	Pressure Controls
LE	Logic Elements
DC	Directional Controls
MV	Manual Valves
SV	Solenoid Valves
PV	Proportional Valves
CE	Coils & Electronics
CB	Cartridge Bodies
BC	Bodies & Cavities
TD	Technical Data

General Description

4-Way, 3 Position, Tandem Center Spool Valve.
 For additional information see Technical Tips on pages SV1-SV5.

Features

- Four way tandem center valve designed to operate double acting cylinders and bi-directional motors, etc.
- One piece cartridge housing ensures internal concentricity
- Coil: Waterproof, hermetically sealed, requires no O'Rings; Symmetrical coil can be reversed without affecting performance.
- All external parts zinc plated

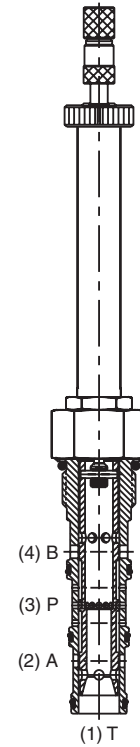
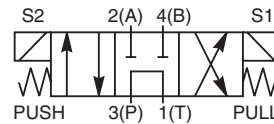
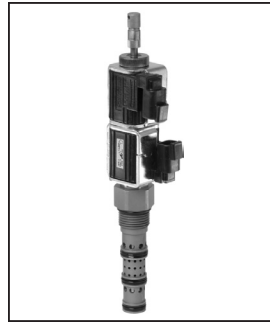

Specifications

Rated Flow	57 LPM (15 GPM)
Maximum Inlet Pressure	350 Bar (5000 PSI)
Maximum Tank Pressure	210 Bar (3000 PSI)
Leakage at 150 SSU (32 cSt)	160 cc/min @ 210 Bar (3000 PSI)
Minimum Operating Voltage	75% of rated voltage at 20°C (72°F).
Response Time	Energized 30-60 ms De-Energized 20-40 ms
Cartridge Material	All parts steel. All operating parts hardened steel.
Operating Temp. Range/Seals	-34°C to +121°C (Nitrile) (-30°F to +250°F) -26°C to +204°C (Fluorocarbon) (-15°F to +400°F)
Fluid Compatibility/Viscosity	Mineral-based or synthetic with lubricating properties at viscosities of 45 to 2000 SSU (6 to 420 cSt)
Filtration	ISO 4406 18/16/13, SAE Class 4
Approx. Weight	.45 kg (1.0 lbs.)
Cavity	C12-4L (See BC Section for more details)

Performance Curves

Pressure Drop vs. Flow (Through cartridge only)

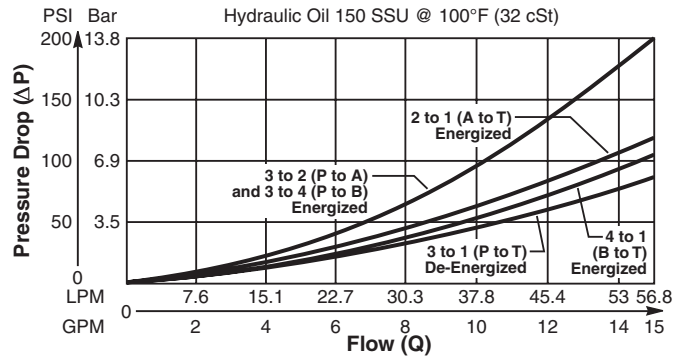

Shift Limit Characteristics (Min. Operating Voltage)

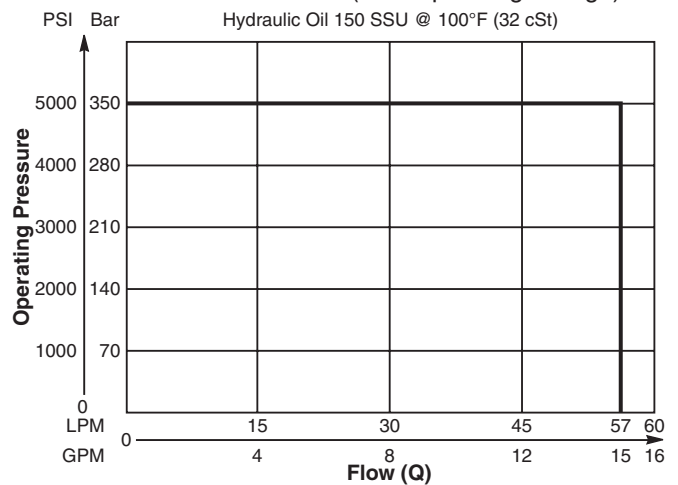

Dimensions Millimeters (Inches)

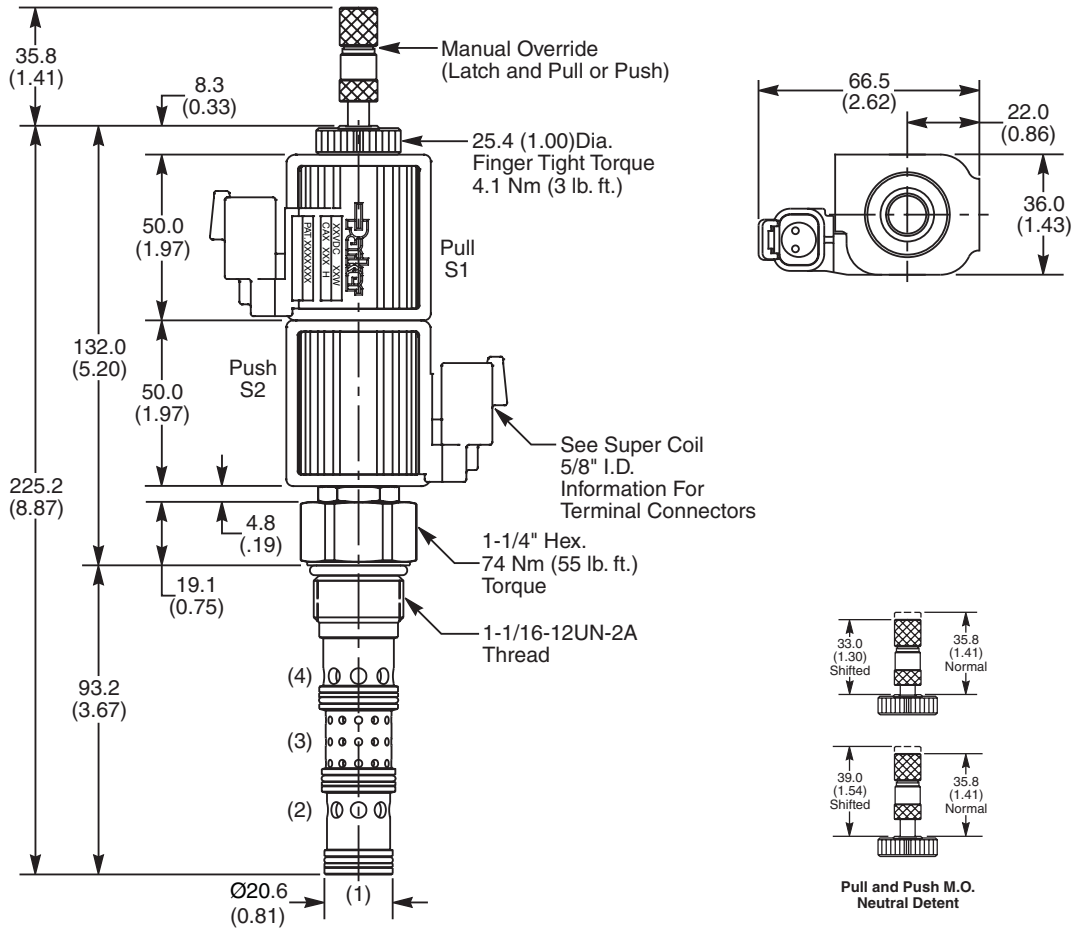

Ordering Information

DSH125	57		
12 Size Solenoid Valve	Style	Override Option	Seals

Highlighted represents preferred options that offer the shortest lead times. Other options may be available, but at extended lead times.

Coil(s) sold separately. Please see section CE of this catalog, 5/8" Super-Coil (CA series), for ordering information.

Code	Style
57	High Flow ('SP' Coil)

Code	Seals / Kit No.
N	Nitrile (SK12-4LN)
V	Fluorocarbon / (SK12-4LV)

Code	Override Options
Omit	None
DN	Latch Operated**

**40 nt/9 lbs.

Order Bodies Separately
 See section BC

B12	-	4L	-	
12 size		4-Way Cavity		Port Size

Code	Port Size / Body Material
12T	SAE-12 / Steel (5000 PSI)
A12T	SAE-12 / Aluminium (3000 PSI)

CV
Check Valves
SH
Shuttle Valves
LM
Load/Motor Controls
FC
Flow Controls
PC
Pressure Controls
LE
Logic Elements
DC
Directional Controls
MV
Manual Valves
SV
Solenoid Valves
PV
Proportional Valves
CE
Coils & Electronics
CB
Carpak Bodies
BC
Bodies & Cavities
TD
Technical Data