



PHD User Guide

Hardware Manual



ENGINEERING YOUR SUCCESS.

Parker Hannifin Canada
Electronic Motion and Controls Division
1305 Clarence Avenue
Winnipeg, MB R3T 1T4 Canada
office +1 204 452 6776
Fax +1 204 478 1749

<http://www.parker.com/emc>

Copyright 2024 © Parker Hannifin Corporation. All rights reserved. No part of this work may be reproduced, published, or distributed in any form or by any means (electronically, mechanically, photocopying, recording, or otherwise), or stored in a database retrieval system, without the prior written permission of Parker Hannifin Corporation in each instance.

Contents

Publication History	V
Safety	VI
Safety symbols	VI
General safety regulations	VI
Welding after installation.....	VII
Construction regulations	VII
Safety during installation	VII
Safety during start-up.....	VII
Safety during maintenance and fault diagnosis.....	VII
1. About the PHD	1
1.1. Diagram conventions.....	3
2. Connectors and pin-outs	5
2.1. Pinouts	5
3. Inputs	10
3.1. PHD28 Inputs	10
3.2. PHD50 Inputs	10
3.3. PHD70 Inputs	11
3.3.1. PHD28/PHD50/ PHD100 analog input capabilities.....	11
3.3.2. PHD70 digital input capabilities	13
3.3.3. PHD50 frequency input capabilities.....	14
3.4. Using inputs as low power outputs	15
3.4.1. Low power, high-side output capabilities.....	16
4. Outputs	17
4.1. PHD28/PHD50/PHD70/PHD100 Low-side outputs.....	17
4.1.1. Low-side output capabilities	17
4.2. Sensor and regulated supply outputs	18
4.2.1. Sensor and regulated supply capabilities.....	19
5. Power	20
6. Communication	21
6.1. Controller area network.....	21
6.1.1. CAN Capabilities	21
6.1.2. PHD CAN Installation Connections	21
6.2. USB	23
7. HMI (Human Machine Interface)	24
7.1. Ambient light sensor	24
7.2. Keypad.....	24
7.3. Buzzer.....	24
7.4. Video.....	24
7.4.1. Video input capabilities	25
7.5. Real Time Clock.....	25
8. Serial Ethernet Recovery Flexcan (SERF) Board and Development Harness	26
8.1. SERF Overview.....	26

8.2.	Available Inputs and Outputs	26
8.2.1.	Switches and Connectors	27
8.2.2.	Jumpers	28
8.2.3.	PHD development harness.....	31
8.2.4.	DB9 Pinout Reference	32
8.2.5.	USB Cabling.....	32
9.	Mounting the PHD	33
9.1.	Dimensions.....	33
9.1.1.	PHD28	33
9.1.2.	PHD50	34
9.1.3.	PHD70	35
10.	Understanding PHD software	36
11.	Environmental Protection	37
11.1.	EMI	37
11.2.	Mechanical environment.....	37
11.3.	ESD	37
11.4.	Climate environment	37
11.5.	Chemical environment	37

Publication History

The following table provides an overview of the changes made to this document over the course of its publication history.

Release	Description of Change, Date
Rev. 001	First release of this document, 2/10/2016
Rev. 002	Updated per Bus. Dev. feedback, 3/3/2016
Rev. 003	Incremental updates from case 30666 reviews 4/6/2016 and 6/27/2016
Rev. 004	Edits based on case 30666 7/11/2016 review and 1042F06 specification
Rev. 005	Edits based on case 30666 9/12/2016 review
Rev. 006	Inputs, outputs and 5V / 12V power supply outputs, pin naming changed, 1/11/2017
Rev. 007	Remove references to Advanced versions per Sales and Marketing request. Will launch at a later date.
Rev. 008	Label pins in C2 as reserved for PHD50/PHD70
Rev. 009	Add SERF Development board section
Rev. 010	High-side/low power output and low-side output specification update.
Rev. 011	Changed PHD70 brightness specification.
Rev. 012	Minor edit to Power section
Rev. 013	Added RS232 debugging pin names to PHD50/70 connector C2 pin-out
Rev. 014	Minor edits to SERF board section.
Rev. 015	Minor edit to Power section.
Rev. 016	Minor edit to PHD70 feature table and Environmental protection section, 1/29/2018
Rev. 017	Removed reference to Digital inputs from PHD28/50, added USB file loading and Recovery switch information.
Rev. 018	Edits per Product Manager markups 3/2019 and 6/2019
Rev. 019	Added Development cable to Chapter 8, 12/4/2019
Rev. 020	Changed digital and frequency inputs PHD50/PHD70, 2/26/2020
Rev. 021	Changed wake functionality text in Sections 3.1, 3.2, 3.3, changed CAN termination in Section 6.1.2, added RTC section 7.6, 4/7/2020.
Rev. 022	Minor edits to Connectors pin names and Input section, 4/29/2020
Rev. 023	Added boot times, 7/27/2022
Rev. 024	Updated the Power Down information in section 5 (09/2023)
Rev. 025	Updated the RAM size (02/2024)
Rev. 025	Added new section: 8.2.5 USB Cabling
Rev. 026	Edited max power output in section 3.4.1. Note added as well
Rev. 027	Removed external fuse in table in section 5. Added new sentence to note 2.

Safety

Do not perform the procedures in this manual unless you are experienced in the handling of electronic equipment.

Contact the manufacturer if there is anything you are not sure about or if you have any questions regarding the product and its handling or maintenance.

The term “manufacturer” refers to Parker Hannifin Corporation.

Safety symbols

The following symbols are used in this document to indicate potentially hazardous situations:



 *Danger! Risk of death or injury.*

 *Warning! Risk of damage to equipment or degradation of signal*

When you see these symbols, follow the instructions carefully and proceed with caution.

General safety regulations

Work on the hydraulics control electronics may only be carried out by trained personnel who are well-acquainted with the control system, the machine, and its safety regulations.

-  Follow the manufacturer’s regulations when mounting, modifying, repairing, and maintaining equipment. The manufacturer assumes no responsibility for any accidents caused by incorrectly mounted or incorrectly maintained equipment. The manufacturer assumes no responsibility for the system being incorrectly applied, or the system being programmed in a manner that jeopardizes safety.
-  Do not use the product if electronic modules, cabling, or connectors are damaged or if the control system shows error functions.
-  Electronic control systems in an inappropriate installation and in combination with strong electromagnetic interference fields can, in extreme cases, cause an unintentional change of speed of the output function.

Welding after installation

Complete as much as possible of the welding work on the chassis before the installation of the system. If welding has to be done afterwards, proceed as follows:

 Do not place the welding unit cables near the electrical wires of the control system.

1. Disconnect the electrical connections between the system and external equipment.
2. Disconnect the negative cable from the battery.
3. Disconnect the positive cable from the battery.
4. Connect the welder's ground wire as close as possible to the place of the welding.

Construction regulations

The vehicle must be equipped with an emergency stop which disconnects the supply voltage to the control system's electrical units. The emergency stop must be easily accessible to the operator. If possible, the machine must be built so that the supply voltage to the control system's electrical units is disconnected when the operator leaves the operator's station.

Safety during installation

 Incorrectly positioned or mounted cabling can be influenced by radio signals, which can interfere with the functions of the system.

Safety during start-up

 ***Danger! Risk of death or injury.*** Do not start the machine's engine before the control system is mounted and its electrical functions have been verified.

Do not start the machine if anyone is near the machine.

Safety during maintenance and fault diagnosis

Before performing any work on the hydraulics control electronics, ensure that

- The machine cannot start moving.
- Functions are positioned safely.
- The machine is turned off.
- The hydraulic system is relieved from any pressure.
- Supply voltage to the control electronics is disconnected.

1. About the PHD

The PHD family of displays are general purpose displays suitable for a wide range of industry applications. There are 3 sizes: 2.8", 5.0" and 7.0". All models are color LCD displays with capacitive touchscreens for interfacing.



Figure 1.1. PHD family of displays

The different models of the PHD and their features are listed in the following tables:

















PHD28	
Characteristic	Description
Display	2.8" 320 x 240 TN LCD, PCAP touchscreen Aspect ratio 4:3
Viewing angle	Theta X +60° / -60°, Theta Y +60° / -50°
Brightness	500 cd/m ²
Contrast ratio	500:1
Readable with polarized glasses	Yes (landscape and portrait orientation)
Processor	Vybrid VF5xxR (Cortex-A5 core) Flash 16 MB RAM 256 MB DDR 400 MHz
Communication	CAN x 1 USB Host/Device x 1 (default is Device)
Inputs	7 General Purpose Inputs; 7 - Analog or 7 - GPIO used for Keypad Interface Ambient Light Sensor
Outputs	2 x low-side 500mA 1 x 5Vdc sensor supply 500mA 1 x 12Vdc sensor supply 500mA Up to 7 high-side, 4.3V @ 5mA
Wake-up sources	CAN, Touch Screen, External Keypad, Wake time ~200mS
Boot time	To splash screen: ~2 sec. To minimal application: ~14 sec.
Connector	Molex MX150, 20 pin

PHD50	
Characteristic	Description
Display Viewing angle Brightness Contrast ratio Readable with polarized glasses	5.0" 800 x 480 TN LCD, PCAP touchscreen Aspect ratio 16:9 Theta X +80° / -80°, Theta Y +80° / -80° 380 cd/m ² 500:1 Yes (landscape and portrait orientation)
Processor	Vybrid VF5xxR (Cortex-A5 core) Flash 32 MB RAM 256 MB DDR 400 MHz
Communication	CAN x 1 USB Host/Device x 1 (default is Device)
Inputs	10 General Purpose Inputs; 1 - Frequency or Quadrature (for rotary encoder) 8 - Analog or 8-10 GPIO for Keypad Interface Ambient Light Sensor 1 Video inputs (NTSC, PAL)
Outputs	2 x low-side 500mA 1 x 5Vdc sensor supply 500mA 1 x 12Vdc sensor supply 500mA Up to 10 high-side, 4.3V @ 5mA
Wake-up sources	CAN, Touch Screen, GPIO, Wake time ~200mS
Boot time	To splash screen: ~2 sec. To minimal application: ~12 sec.
Connector	2 x Molex MX150, 20 pin

PHD70	
Characteristic	Description
Display Viewing angle Brightness Contrast ratio Readable with polarized glasses	7.0" 800 x 480 IPS LCD, PCAP touchscreen Aspect ratio 16:9 Theta X +80° / -80°, Theta Y +80° / -80° 430 cd/m ² 600:1 Yes (landscape and portrait orientation)
Processor	Freescale iMX6Solo/Dual/Quad 800 MHz Standard Version: Flash 1 GB RAM 512 MB DDR3 Low Memory Version: Flash 256 MB RAM 256 MB DDR3
Communication	CAN x 2 USB Host/Device x 1 (default is Device)
Inputs	10 General Purpose Inputs; 1 - Quadrature (for rotary encoder) 8 - Digital (active-high) or 8-10 GPIO for Keypad Interface Ambient Light Sensor 2 simultaneous Video Inputs (NTSC, PAL)
Outputs	2 x low-side 500mA 1 x 5Vdc sensor supply 500mA 1 x 12Vdc sensor supply 500mA Up to 10 high-side, 4.3V @ 5mA
Wake-up sources	CAN (Traffic on either CAN will wake), Touch, GPIO, Wake time ~200mS
Boot time	To Splash Screen: ~1 Sec. To minimal application: ~7 sec.
Connector	2 x Molex MX150, 20 pin

1.1. Diagram conventions

The following symbols are used in the schematic diagrams in this document:

Diagram Conventions	
Symbol	Meaning
	General input
	General output
	Frequency input
	Analog input
	Frequency sensor
	Pulse sensor
	Resistive sensor
	General sensor
	Application switch
	Load
	Pull-down resistor
	Pull-up resistor
	Battery
	Fuse
	Resistor
	Ground
	Chassis ground

2. Connectors and pin-outs

The connector on the rear panel of the PHD28 is;

- MX150 - Vehicle Harness Connector key B

The connectors on the rear panel of the PHD50 are;

- 2 x MX150 - Vehicle Harness Connectors, key A & B

The connectors on the rear panel of the PHD70 are;

- 2 x MX150 - Vehicle Harness Connectors, key A & B

The Molex MX150 connectors are used to interface the PHD family to power, inputs, outputs and USB..

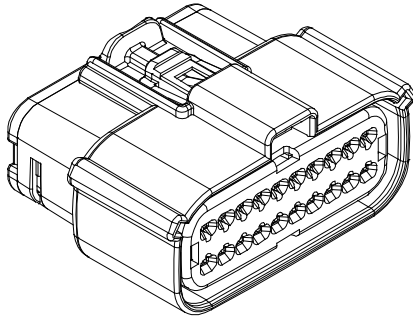

Figure 2.1. Molex MX150 connector example

Mating Connector Part Numbers		
Connector	Molex part no. with CPA locking clip	Molex part no. without CPA locking clip
J1 connector (gray), 20-pin, key option B	334722007	334722002
J2 connector (black), 20-pin, key option A	334722006	334722001
Contacts	330013004 (16-20 awg gold)	330013004 (16-20 awg gold)

The pins in the Molex MX150 connectors are used for power, input, output, CAN, LIN, and J1708 communication channels, depending on version.

2.1. Pinouts

The pins in the Molex MX150 connectors connect to power, inputs, outputs, CAN and USB communication channels.

The following tables show the pinouts for each connector:

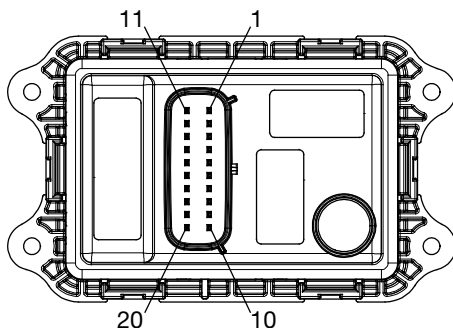

Figure 2.2. Back of PHD28 showing connector

PHD28 J1 Connector Pinout	
Pin	Function
1	GPIO7 (analog input/low power output)
2	GPIO1 (analog input/low power output)
3	GPIO6 (analog input/low power output)
4	OUTPUT2 (low-side output)
5	CAN1_TERM (CAN termination)
6	CAN1_SHLD (CAN shield)
7	CAN1_L (CAN low)
8	CAN1_H (CAN high)
9	GND (Negative battery)
10	+VBATT (Positive battery)
11	GPIO5 (analog input/low power output)
12	GPIO4 (analog input/low power output)
13	GPIO3 (analog input/low power output)
14	GPIO2 (analog input/low power output)
15	USB_D-
16	USB_D+
17	USB_GND
18	USB_VBUS / P5V0 (5V sensor supply)
19	P12V0 (12V regulated supply)
20	OUTPUT1 (low-side output)

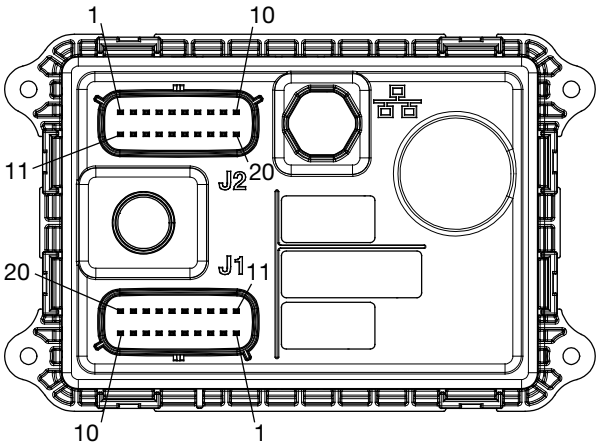

Figure 2.3. Back of PHD50 showing connectors

PHD50 J1 Connector Pinout	
Pin	Function
1	GPIO7 (analog input)
2	GPIO1 (analog input)
3	GPIO6 (analog input/low power output)
4	OUTPUT2 (low-side output)
5	CAN1_TERM (CAN termination)

PHD50 J1 Connector Pinout	
Pin	Function
6	CAN1_SHLD (CAN shield)
7	CAN1_L (CAN low)
8	CAN1_H (CAN high)
9	GND (Negative battery)
10	+VBATT (Positive battery)
11	GPIO5 (analog input/low power output)
12	GPIO4 (analog input/low power output)
13	GPIO3 (analog input/low power output)
14	GPIO2 (analog input/low power output)
15	USB_D-
16	USB_D+
17	USB_GND
18	USB_VBUS
19	P12V0 (12V regulated supply, hooked internally to J2 Pin 10)
20	OUTPUT1 (low-side output)

PHD50 J2 Connector Pinout	
Pin	Function
1	GPIO10 (quadrature input)
2	GPIO9 (quadrature or frequency input)
3	NC
4	NC
5	NC
6	VIDEO1_GND
7	VIDEO1
8	NC
9	Ground
10	P12V0 (12V regulated supply, hooked internally to J1 Pin 19)
11	Ground
12	Ground
13	GPIO8 (analog input)
14	P5V0 (5V sensor supply)
15	RS232-RX (debugging use only)
16	RS232-TX (debugging use only)
17	NC
18	NC
19	NC
20	NC

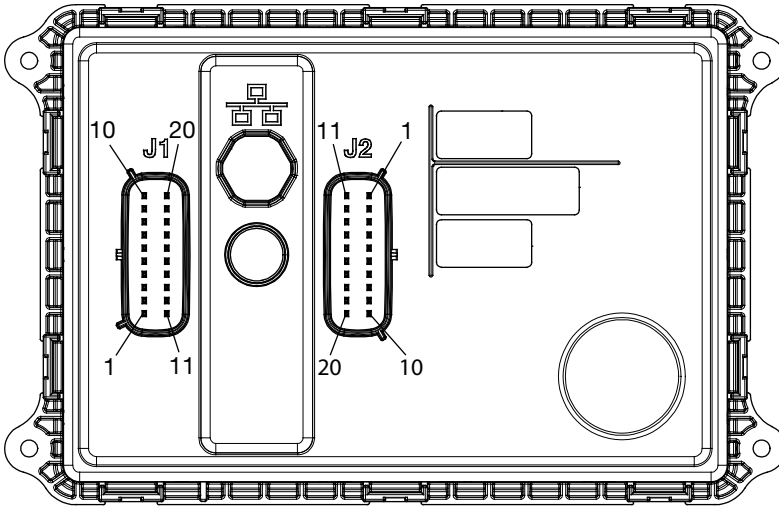

Figure 2.4. Back of PHD70 showing connectors

PHD70 J1 Connector Pinout	
Pin	Function
1	GPIO7 (digital input/low power output)
2	GPIO1 (digital input/low power output)
3	GPIO6 (digital input/low power output)
4	OUTPUT2 (low-side output)
5	CAN1_TERM (CAN termination)
6	CAN1_SHLD (CAN shield)
7	CAN1_L (CAN low)
8	CAN1_H (CAN high)
9	GND (Negative battery)
10	+VBATT (Positive battery)
11	GPIO5 (digital input/low power output)
12	GPIO4 (digital input/low power output)
13	GPIO3 (digital input/low power output)
14	GPIO2 (digital input/low power output)
15	USB_D-
16	USB_D+
17	USB_GND
18	USB_VBUS
19	P12V0 (12V regulated supply, hooked internally to J2 Pin 10)
20	OUTPUT1 (low-side output)

PHD70 J2 Connector Pinout	
Pin	Function
1	GPIO10 (quadrature or low power output)
2	GPIO9 (quadrature or low power output)
3	CAN2_SHLD
4	CAN2_L

PHD70 J2 Connector Pinout	
Pin	Function
5	CAN2_H
6	VIDEO1_GND
7	VIDEO1
8	VIDEO2
9	VIDEO2_GND
10	P12V0 (12V regulated supply, hooked internally to J1 Pin 19)
11	Ground
12	Ground
13	GPIO8 (digital input)
14	P5V0 (5V sensor supply)
15	RS232-RX (debugging use only)
16	RS232-TX (debugging use only)
17	NC
18	NC
19	NC
20	NC

3. Inputs

The PHD has digital, frequency, and analog inputs.

⚠ Damage to equipment! Do not connect inputs directly to unprotected inductive loads such as solenoids or relay coils, as these can produce high voltage spikes that may damage the PHD. If an inductive load must be connected to an input, use a protective diode or transorb.

3.1. PHD28 Inputs

The PHD28 has up to 7 analog inputs:

- GPIO1 through GPIO7

Analog inputs are typically used to read electrical signals that span a voltage range. Depending on the PHD model, certain inputs can also be configured as inputs for the wake-up functionality. On the PHD28, Touch, CAN1, and GPIO 1 through GPIO7 can be configured for wake-up functionality. Additionally, certain inputs can be configured as low power outputs. See section 3.4 for more information.

The different configurations are done in software.

3.2. PHD50 Inputs

The PHD50 has up to 8 analog inputs:

- GPIO1 through GPIO8

Analog inputs are typically used to read electrical signals that span a voltage range. Depending on the PHD model, certain inputs can also be configured as inputs for the wake-up functionality. On the PHD50 the wake options are, Touch, CAN and GPIO1 through GPIO8. Wake on GPIO9 and 10 is allowed on the PHD50 only if an encoder is not selected, or the FIN input is not selected. On the PHD50 with Enhanced Power Management, with the extended wake/sleep functionality, only GPIO1 can be used as a wake signal. Additionally, certain inputs can be configured as low power outputs. See section 3.4 for more information.

The different configurations are done in software.

On the PHD50, GPIO 9 and GPIO10 can be configured as a single frequency input on GPIO9, or a single quadrature encoder input on GPIO9 and GPIO10.

The encoder inputs are provided for the uses of a rotary encoder as an input device. The encoder states must change 4 times, or once per detent in the shaft rotation to be recognized by the PHD50, see chart below for the required waveform.

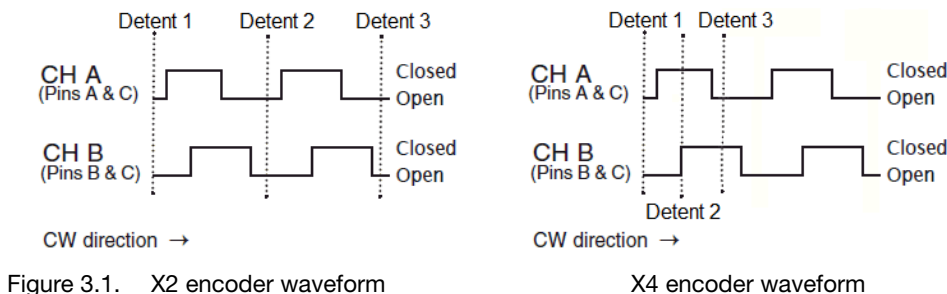

Figure 3.1. X2 encoder waveform

X4 encoder waveform

3.3. PHD70 Inputs

The PHD70 does not support analog inputs.

The PHD70 has up to 8 digital inputs:

- GPIO1 through GPIO10

Digital inputs are typically used to read electrical signals from switches.

Depending on the PHD model, certain inputs can also be configured as inputs for the wake-up functionality. On the PHD70 the wake options are, CAN, Touch and GPIO1 through GPIO8 can be used as wake signals. Wake on GPIO9 and 10 is allowed on the PHD70 only if an encoder is not selected.

Note: on the PHD70, wake on CAN will wake on CAN traffic on either CAN1 or CAN2.

Additionally, certain inputs can be configured as low power outputs. See section 3.4 for more information.

The different configurations are done in software.

The PHD70 has 1 quadrature encoder input on GPIO9 and GPIO10.

The encoder inputs are provided for the uses of a rotary encoder as an input device. The encoder states must change 4 times per detent in the shaft rotation to be recognized by the PHD70, see chart below for the required waveform.

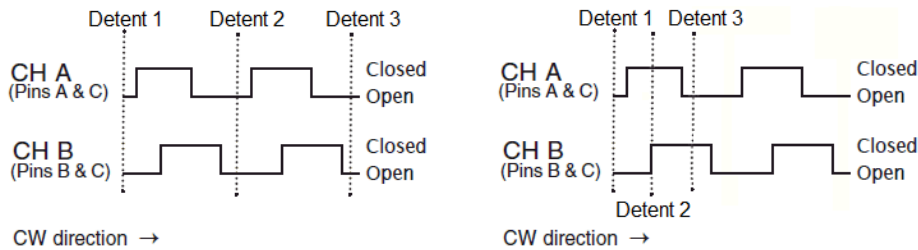

Figure 3.2. X2 encoder waveform

X4 encoder waveform

3.3.1. PHD28/PHD50 analog input capabilities

The PHD28 and PHD50 have analog inputs. These inputs are also configurable as digital inputs by programming the voltage threshold in the Lua scripting tool to make them digital.

Analog inputs are useful for reading potentiometers and Hall Effect signals.

The following table provides specifications for the analog inputs:

HW Analog Input Specifications				
Item	Min	Nom	Max	Unit
Input voltage range	0		5	V
Input pin capacitance		10		μF
Pull-down resistance		26.2		kΩ
Response to step change		50		ms
Over-voltage			36	V
Resolution - 10 bit		5		mV
Offset error		11		mV
Accuracy		3		%

3.3.1.1. Analog input connections

Analog inputs are susceptible to system noise, which can affect the accuracy of the signal. Signal accuracy can also be affected by ground level shift, which can cause inputs to activate when they shouldn't.

System noise

To prevent noise pickup on the sensors,

- Use the shortest possible wires when connecting analog inputs to sensors.

The following diagram shows connect an analog input to reduce system noise:

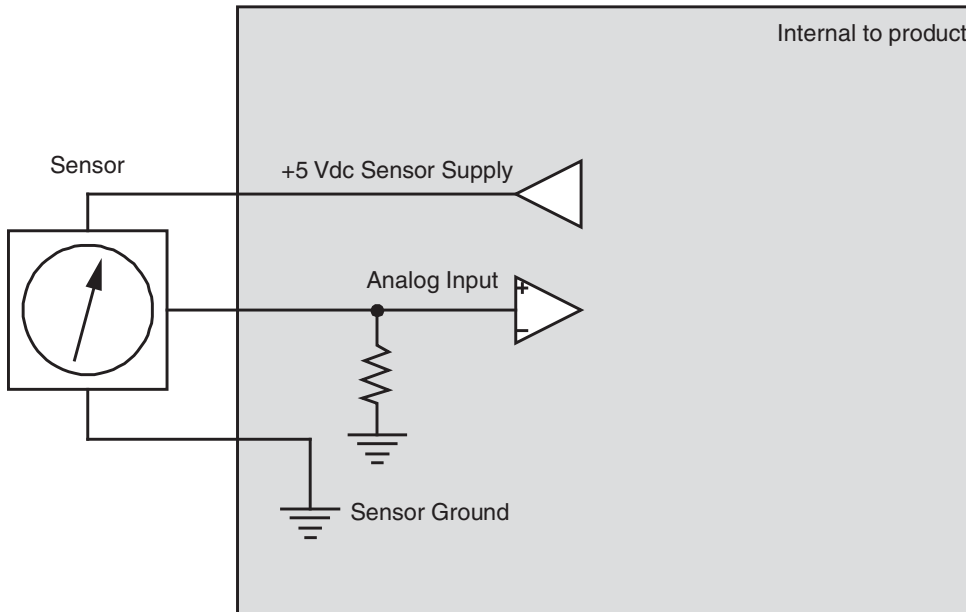

Figure 3.3. Analog input system noise reduction

Ground level shift

To reduce ground level shift:

1. Dedicate one of the system ground inputs (GND) to sensors that have dedicated ground wires and connect all sensor grounds to this system ground input.
2. Splice the other system ground inputs together in the vehicle harness (close to the connector) to provide a better ground for the noisier low-side outputs and digital circuits.
3. Position the sensor's ground connection near the system ground connections to ensure that the signal remains within the digital activation range of the input.

Note: The system ground inputs are rated for low-current signals, which ensures the sensor's ground is very close in voltage potential to the system ground.

Note: Sensors that don't have a dedicated ground wire are typically grounded to the vehicle chassis through the sensor's body.

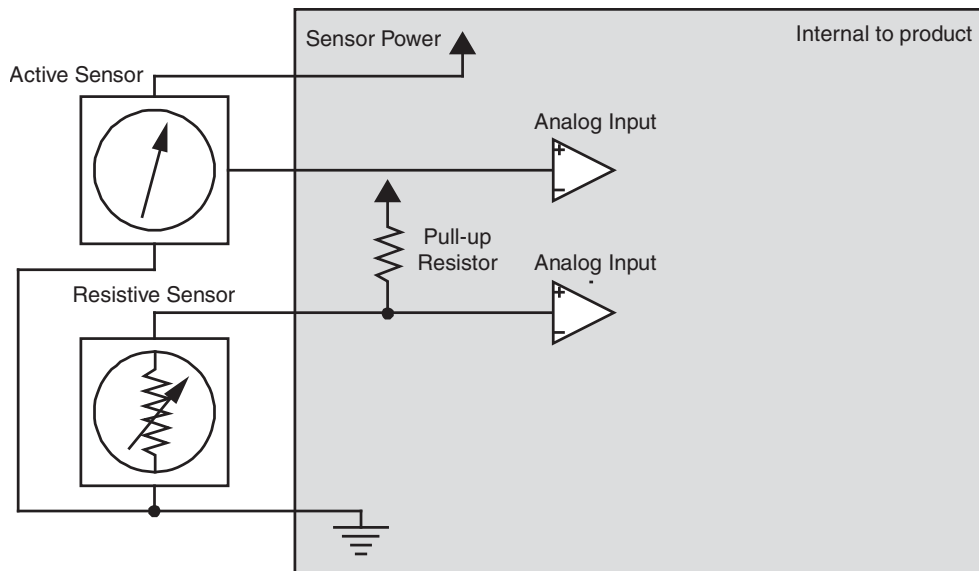

Figure 3.4. Analog input ground shift connection for sensors that have dedicated ground wires

3.3.2. PHD70 digital input capabilities

- The PHD70 has up to 10 traditional active high digital inputs.
- The PHD70 digital inputs can also be configured as low power digital outputs.

The following table provides specifications for the PHD's digital inputs:

HW Digital Input Specifications				
Item	Min	Nom	Max	Unit
Input voltage range	0		32	V
Pull-down resistance		26.2		k Ω
Pull-up resistance (to 4.3V min / 5V max)		1.2		k Ω
Negative threshold	1.545			V
Positive threshold			4.008	V
Cutoff frequency (hardware)		1590		Hz
Over-voltage			36	V
Wetting current (through pull-up)		4.3		mA

3.3.2.1. Active-High Digital Input Connections

A digital input is typically connected to a switch that is either open or closed.

- When an active-high switch is open, the pull-down resistor ensures that no voltage exists on the input signal, which will be interpreted by the PHD as inactive.
- When the switch is closed, the input is connected to battery voltage, which will be interpreted by the PHD as active.

For an input that is active-high

- It must be connected to battery power so that there is a battery connection when the state of the input changes.

- The power provided to the digital switch connected to the input must be provided through a fuse in the wire harness.

A typical active-high digital input connection is shown below:

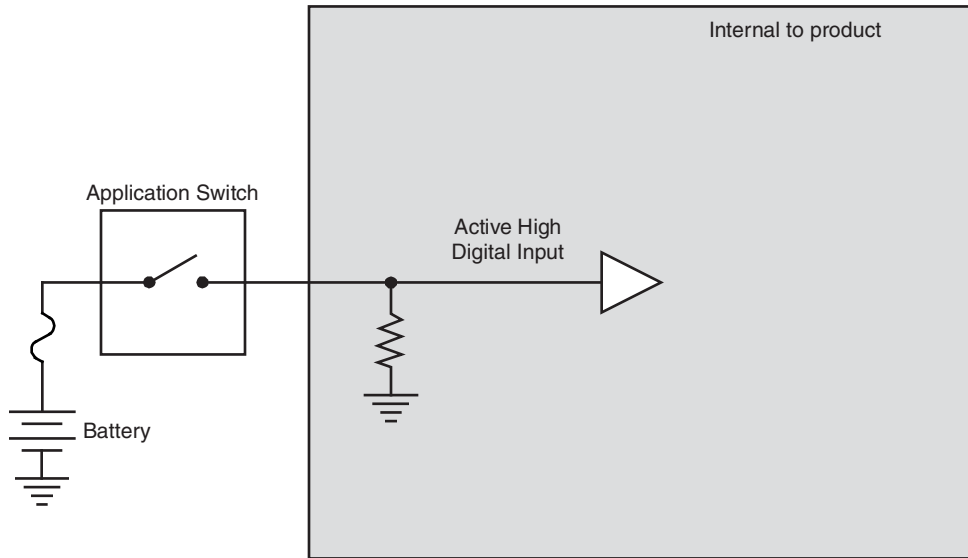

Figure 3.5. Active-high digital input

3.3.3. PHD50 frequency input capabilities

The PHD50 has 1 frequency input on `GPIO9` that can be configured as `FIN` or `GPIO`. The frequency input is ideal for use with hall-effect type sensors.

The following table provides specifications for the frequency input:

HW Frequency Input Specifications				
Item	Min	Nom	Max	Unit
Input range	0	5	32	V
Negative threshold	1.545			V
Positive threshold			4.008	V
Input capacitance at pin		0.1		μ F
Over-voltage			36	V
Frequency accuracy		3		%
Frequency range (see note)	0		1500	Hz
Pull-up resistor to min 4.3V, max 5V		1.2		k Ω
Pull-down resistor		26.2		k Ω
<i>Note:</i> Electrically signals to 0 are possible, but the software will limit the minimum measurable frequency				

3.3.3.1. DC-Coupled Frequency Input Connections

When connecting DC-coupled frequency inputs, be aware of system noise and ground level shift.

System Noise

DC-coupled frequency inputs are more susceptible to system noise than digital inputs.

To reduce system noise:

- Connect DC-coupled frequency inputs to sensors that produce signals with no DC offset.
- Use the shortest possible wires when connecting DC-coupled frequency inputs to sensors to prevent noise pickup on the sensors.

Ground Level Shift

Ground level shift affects the accuracy of DC-coupled frequency inputs. Ground level shift refers to the difference between the system ground input (GND) voltage, and the sensor ground voltage.

To reduce ground level shift:

- If there are more than 1 GND pins in the system, dedicate one of them to sensors that have ground wires, and connect all sensor grounds to that system ground pin.
- Splice the other system ground inputs together in the vehicle harness (close to the connector), to provide a better ground for the noisier low-side outputs and digital circuits.
- Ensure the sensor's ground connection is close to the system ground connections. This will help ensure the signal remains within the digital activation range of the input.

Note: The PHD system ground inputs are rated for low-current signals, which ensures the sensor's ground is very close in voltage potential to the system ground.

Note: Sensors that don't have a dedicated ground wire are typically grounded to the vehicle chassis through the sensor's body.

The following shows a typical DC-coupled frequency input connection:

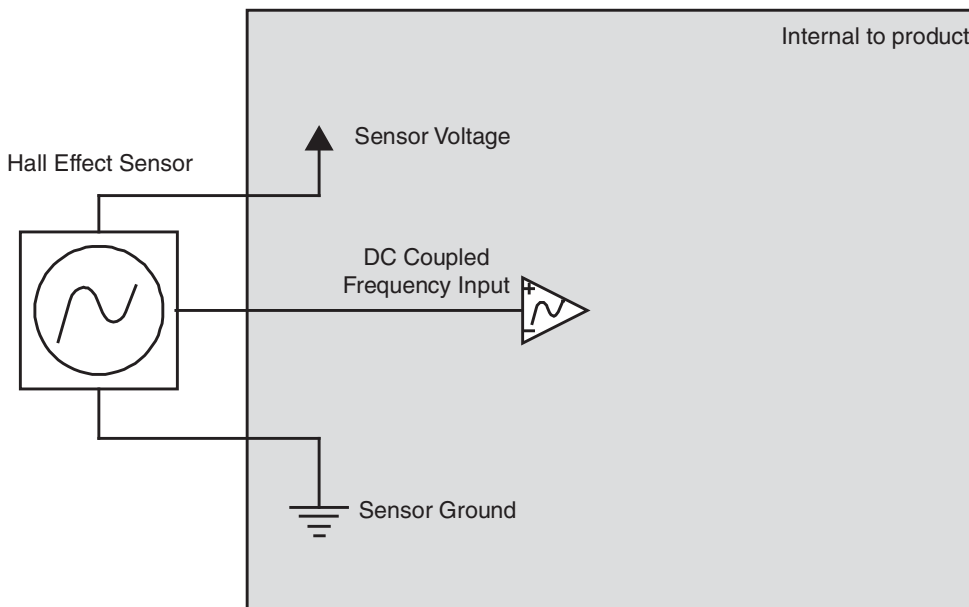

Figure 3.6. DC-coupled frequency input installation connections

3.4. Using inputs as low power outputs

Certain input pins, (GPIO1 through GPIO7) of the PHD28 and (GPIO2 through GPIO6) of the PHD50, may be used as high side, low voltage / low current outputs. All of the inputs (GPIO1 through GPIO10) of the PHD70 may be used this way.

A software configurable internal pull-up to 5V provides the drive for this flexible usage of the pins. These

outputs are suitable for driving LEDs and other small loads.

3.4.1. Low power, high-side output capabilities

The following table provides specifications for the inputs when used as low power outputs.

HW Low Power Output Specifications				
Item	Min	Nom	Max	Unit
Operational voltage range	9		32	V
Output resistance w.r.t. GND (output off)		26.2		k Ω
Output voltage	4.3		5.0	V
Output current			4.3	mA
Leakage current (output off)		1		μ A
Output pin capacitance		10		nF

Note: A pull up resistor is used in the Low Power Output circuits. For the PHD50 and PHD28, the value is 1.0k Ohms and for the PHD70 and PHD100 the value is 1.2k Ohms.

3.4.1.1. Low power, high-side output connections

You must be aware of the following when connecting the low power, high-side outputs:

- the outputs are connected to the internal +5 Vdc supply through a pull-up resistor. Each output is derated to 4.3 V. Maximum load on each output is 358 mA.
- the outputs can provide power to LED or other small loads in a vehicle.

When connecting the low power, high-side outputs, ensure you follow these best practices:

- the outputs should not be connected to loads that will draw currents greater than the maximum current.
- The grounds for the loads should be connected physically close to the PHD power grounds.

The following shows a typical high-side output connection:

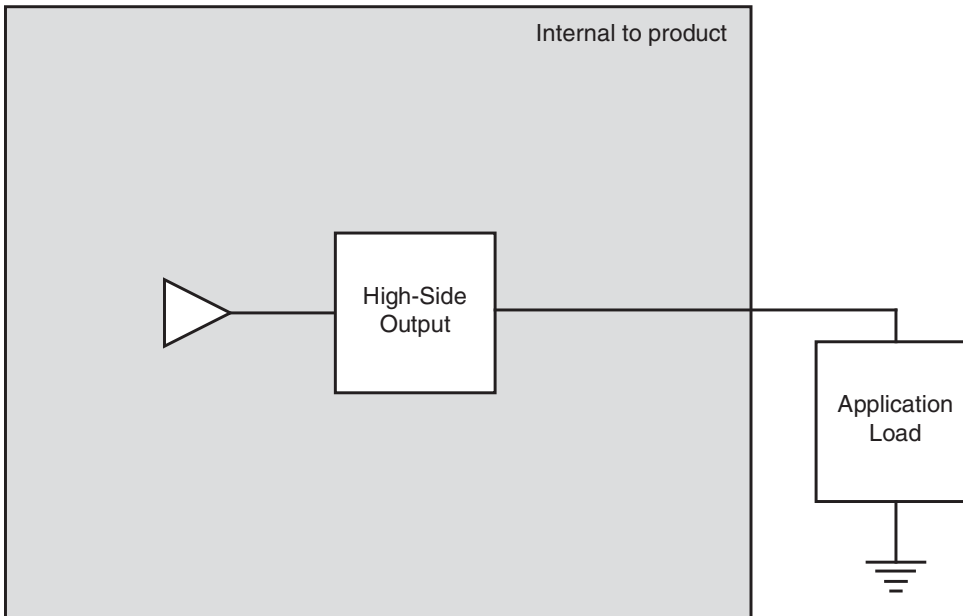

Figure 3.7. High-side output installation connections

4. Outputs

There are 3 types of outputs on the PHD family of displays.

- Low-side outputs
- High-side outputs
- Power

4.1. PHD28/PHD50/PHD70 Low-side outputs

The PHD family has two low-side outputs, with the following pin assignments:

- OUTPUT1 through OUTPUT2

4.1.1. Low-side output capabilities

The characteristics of the PHD low-side outputs are shown in the following tables.

Low-Side Output Specifications				
Item	Min	Nom	Max	Unit
Output current			500	mA
On resistance			550	mΩ
Max. voltage applied to pin			36	V
Current limit in short-to-ground condition	1.0	1.5	1.9	A
Pull-down resistance (PHD28/50)		402.4		kΩ
Pull-down resistance (PHD70)		436.5		kΩ
Feedback gain (Vmicro/Vpin) (see note)		3/33		V/V
Feedback max readable voltage			33	V
Feedback cut-off (3dB) frequency		32		Hz
<i>Note:</i> Vmicro is the voltage at the micro A/D pin, and Vpin is at the external connector pin. The tolerance of the Vpin measurement using nominal gain is ±0.5 V.				

The outputs have analog feedback for error detection.

Low-Side Output Error Detection			
Driver State	Output Condition	Feedback voltage	Error Detected?
Off	Open	0 V	No
Off	Short-to-battery	V/11	Yes
Off	Short-to-ground	0 V	No
On	Open	0 V	No
On	Short	>V/11 (see note)	Yes
<i>Note:</i> An over-temperature fault results in driver output cycling.			

4.1.1.1. Low-side output connections

When connecting low-side outputs, note that

- low-side outputs are connected to a common internal ground point that is connected to the battery ground (GND).
- low-side outputs provide switched ground to any load type in a vehicle.
- low-side outputs can sink up to 0.5 A.

When connecting a load to a low-side output, ensure that the load will not drive currents greater than the maximum specified peak current or the maximum specified continuous current.

The following shows a typical low-side output connection:

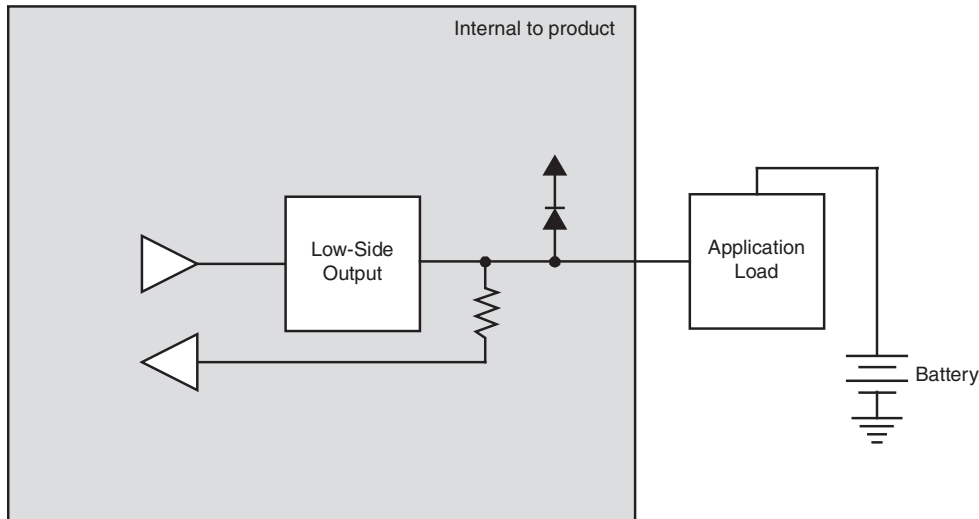

Figure 4.1. Low-side outputs with current sense installation connections

4.2. Sensor and regulated supply outputs

The PHD has 2 types of sensor supply pins, labeled USB_VBUS, P5V0 and P12V0 dedicated to providing power to external sensors and devices.

- 5V USB or sensor supply
- 12V regulated supply

The PHD28 has 1 of each type of supply:

- USB_VBUS / P5V0 is a 5V supply
- P12V0 is a 12V regulated supply

The PHD50 and PHD70 have 2 x 5V and 1 x 12V supplies:

- USB_VBUS and P5V0 are independent supplies
- P12V0 are 2 pins assigned to the 12V regulated supply

Warning! Do not drive more than 500 mA of current through the combined P12V0 pins. Doing so will cause the pins to protect themselves by dropping the voltage, which will result in a lack of power to the sensors and other devices, causing unknown vehicle responses.

4.2.1. Sensor and regulated supply capabilities

USB_VBUS and P5V0 are 5 V linear power supplies capable of continuously providing 500 mA to external sensors and the USB port.

5 V Sensor/USB Supply Output				
Parameters	Min	Nom	Max	Unit
Output voltage	4.5	5.0	5.5	V
Current limit			500	mA

P12V0 are 2 pins assigned to the 12 V linear power supply capable of continuously providing 500 mA to external devices.

12 V Regulated Supply Output Parameters				
Parameter	Min	Nom	Max	Unit
Output voltage (see note)	10.8	12.0	13.2	V
Current limit (total of both pins)			500	mA
Note: the 12 V sensor supply is offset 1.3 V from VBATT. In low voltage conditions the voltage drop can result in the sensor supply going below minimum range.				

5. Power

The PHD family is powered by a direct battery connection. The display is turned on by applying power to one of the wake-up inputs or a CAN message, depending on configuration in software. The direct battery input is protected against vehicle transients such as load dump and inductive load switching, etc. It is also protected against reverse battery voltage of -33 V through the use of a high-current path that will cause an external fuse to blow.

The PHD operates in a 12 V or 24 V system and can operate from 9 V up to 32 V with over-voltage protection at 33 V.

Unexpectedly removing the VBATT power from the PHD may result in data corruption in the non-volatile memory, missed CAN messages, or other missed events. To help prevent this, it is recommended that an input be defined as the Ignition input, separate from the VBATT Power. The ignition input is intended for the application to determine the on or off status of the PHD. When the ignition is turned “off” an appropriate power down sequence must be run in the application. This sequence must be run before the VBATT power is removed, or the PHD is put into sleep mode. Examples of processes to review for the power down sequence are clearing CAN buffers, handling any final events, and completing and stopping any reads and writes to non-volatile RAM. Final testing of the application by the application programmer is required and must include testing related to power on and off actions, as well as entering and coming out of sleep mode.

The following table provides specifications for the PHD power:

Parameter	Min	Nom	Max	Unit
Input voltage for normal operation	9	-	32	V
Minimum cranking voltage (see note 1)	7	-		V
Over-voltage protection	-	-	33	V
Reverse battery protection (see note 2)	-	-	-33	V
Maximum continuous current (see note 3)				
VBATT=13.8 V		0.44	1.781	A
VBATT=27.0 V		0.22	0.93	A
Rating of External Fuse	-	-	10	A

Note 1: The unit will operate below 9 V, down to 7 V, but the LCD back-lighting may be dim.

Note 2: A reverse battery condition causes an external fuse to blow. An external fuse in the VBATT+ line is required to protect against reverse battery.

Note 3: This is the maximum expected value, not including the additional draw of the outputs, or the regulated 5VDC and 12VDC supplies.

Note 4: The PHD70 resets if VBAT drops below 9VDC and will wake from sleep.

Note 5: If Voltage drops below the minimum cranking voltage while asleep, the unit will reboot when the power resumes above the minimum cranking voltage instead of waking.

6. Communication

The types of communication available to the PHD family are Controller Area Network (CAN) communication and USB host.

6.1. Controller area network

The PHD28 and PHD50 have 1 Controller Area Network (CAN) communication port available. The PHD70 has 2 CAN communication ports available.

The PHD family hardware provides controller area network (CAN) communication according to the SAE J1939 specification, making the PHD compatible with any CAN-based protocol through software.

CAN communication is used to communicate the status of multiple modules that are connected to each other in the same network.

6.1.1. CAN Capabilities

The CAN communicates information at a selectable rate from 125 kbps to 500 kbps. Lack of regular CAN communication is an indication that there is either a problem with a module in the network, or a problem with the CAN bus.

CAN communication provides a feature called Wake on CAN, which is a way to provide power control to the PHD.

Wake on CAN provides a low-current sleep mode that turns on the PHD when a CAN message is received by the module.

It is not possible to filter messages that are used to turn on the PHD using Wake on CAN. For this reason, any message will turn on the PHD. The application software must be written to determine how the PHD will behave when it is turned on.

The following table provides specifications for the HW CAN:

HW CAN Specifications				
Item	Min	Nom	Max	Unit
Baud rate limitations (hardware)	-	-	500	kbps
Baud rate limitations (software)	125	-	500	kbps
Wake on CAN current draw	-	-	500	uA
Termination resistor	120	-	-	Ω

6.1.2. PHD CAN Installation Connections

The CAN connection for the PHD should conform to the J1939 standard. The J1939 standard is a robust automotive specification that is a good CAN installation guideline even when the J1939 CAN protocol is not being used.

For a list of J1939 connection considerations, refer to the SAE J1939 specifications available through the Society for Automotive Engineers. SAE J1939-11 covers the physical aspects of the CAN bus including cable type, connector type, and cable lengths.

The standard variant of the PHD does not have a CAN termination resistor applied by default. The PHD displays have a CAN termination pin that allows the internal termination resistor to be applied for CAN1 only.

To implement the internal CAN1 internal termination resistor, the CAN_TERM pin should be wired as shown.



Figure 6.1. PHD CAN_TERM wiring

Note: Note this is not available on CAN2 of the PHD70.

The following lists the elements that are required for a J1939 CAN connection:

- **CAN Cable:** A shielded twisted-pair cable should be used when connecting multiple modules to the CAN bus. The cable for the J1939 CAN bus has three wires: CAN High, CAN Low, and CAN Shield (which connect to the corresponding CAN_HIGH, CAN_LOW, and CAN_SHIELD pins on the connector). When a module does not have a CAN_SHIELD pin, the CAN Shield should be connected to an available ground terminal attached to the negative battery. The CAN cable must have an impedance of 120 Ω .
- The CAN cable is very susceptible to system noise; therefore, CAN shield must be connected as follows:
 - a. Connect CAN Shield to the point of least electrical noise on the CAN bus.
 - b. Connect CAN Shield as close to the center of the CAN bus as possible.
 - c. Use the lowest impedance connection possible.

Note: Ground loops can damage electronic modules. The CAN Shield can only be grounded to one point on the network. If grounded to multiple points, a ground loop may occur.

- **CAN Connectors:** Industry-approved CAN connectors are manufactured by ITT Cannon and Deutsch, and come in either T or Y configurations.
- **CAN Harness:** The CAN harness is the main backbone cable that is used to connect the CAN network. This cable cannot be longer than 40 meters and must have a 120 Ω terminating resistor at each end. The 120 Ω terminating resistors eliminate bus reflections and ensure proper idle-state voltage levels.
- **CAN Stubs:** The CAN stubs cannot be longer than 1 meter, and each stub should vary in length to eliminate bus reflections and ensure proper idle state voltage levels.
- **Max Number of Modules in a System:** The CAN bus can handle a maximum of 30 modules in a system at one time.

The following shows a typical CAN connection using the SAE J1939 standard:

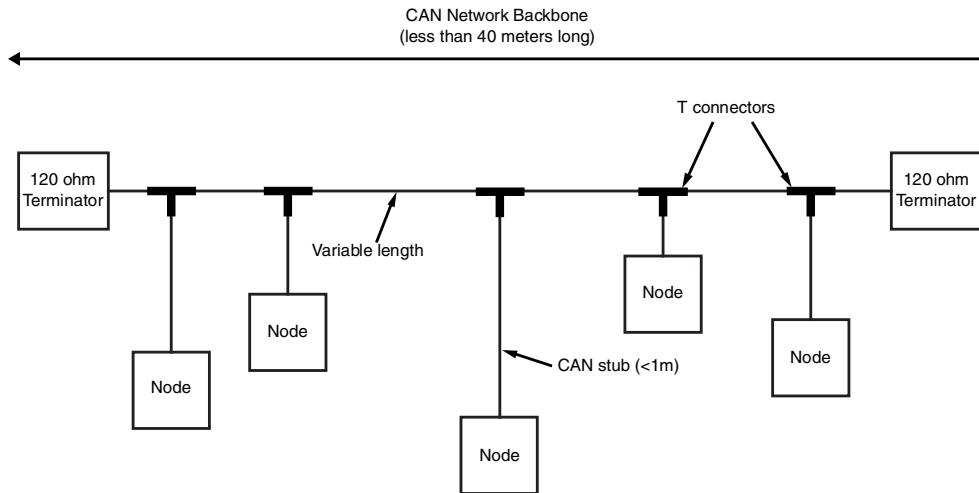

Figure 6.2. J1939 CAN connection

6.2. USB

The PHD family supports one USB port capable of full speed USB 2.0. The USB port is configured as Host or Device based on settings in software. The USB port allows you to connect temporarily to the unit for the purpose of updating code or configuring the unit.

The following table provides specifications for the USB port:

USB Device Specifications				
Item	Min	Nom	Max	Unit
Communication speed - Full Speed			12	Mbps
Capacitance of I/O to ground		2.5	3.5	pF
Reverse standoff voltage (note 1)			5	V
<i>Note 1:</i> USB connectors are not rated to survive a short to vehicle battery.				

To load the application file in USB Device Mode:

1. Make sure the PHD is powered off and the USB cable is unplugged.
2. Power Up the PHD
3. Connect the USB cable.
4. Send the application file.
5. PHD should reboot in about 20-30 seconds after the file is sent.

7. HMI (Human Machine Interface)

The PHD family has an easy to use graphical user interface consisting of a color LCD and touchscreen with the option of adding a keypad.

7.1. Ambient light sensor

All PHD displays support auto level, meaning that if enabled, will automatically adjust the display's backlight, based on the amount of ambient light. The ambient light is sensed and measured via the sensor opening on the glass face. The backlight is at full brightness when the auto adjustment is enabled.

PHD28 and PHD50	
Light Sensor Reading	Backlight Setting
≥ 3840	20%
< 1024	100%

PHD70	
Light Sensor Reading	Backlight Setting
> 800	20%
< 800	90%

Note 1: Backlight change rate is damped for smoother changes.

7.2. Keypad

The PHD family of displays does not have an integral keypad. The PHD will support an external keypad (e.g. four button interface, five button interface, 10+ key grid keypad) via the GPIO.

7.3. Buzzer

The PHD units themselves do not house a buzzer. A regulated 12Vdc supply is provided from the pins of the main connectors and this can be used to power a buzzer. Note that this interface is limited to 500mA. To drive the other leg of an external buzzer, low-side output 1 or 2 can drive a steady state low output to drive a buzzer. This low-side output is also capable of sinking 500mA.

7.4. Video

The PHD50 and PHD70 support analog video cameras.

- PHD50 has 1 video input
- PHD70 has 2 video inputs

The PHD50 supports one D1 resolution PAL/NTSC input.

The PHD70 supports two D1 resolution PAL/NTSC inputs and can display both video feeds simultaneously.

7.4.1. Video input capabilities

The following table provides specifications for the video inputs.

Video Input Specifications				
Parameters	Min	Nom	Max	Unit
Input voltage range	-5.6		5.6	V
Input resistance		75		Ω
Capacitance at pin		65	100	pF

7.5. Real Time Clock

The Standard PHD70 (not the reduced memory version) supports a Real Time Clock (RTC). The RTC values can be set and read using the corresponding API calls outlined in the PHD API Manual.

The RTC values are maintained during power down by a super-capacitor mounted in the PHD70.

The following table provides specifications for the RTC.

Real Time Clock Specifications				
Parameters	Min	Nom	Max	Unit
Setting retention time	60	81	100	Hrs

8. Serial Ethernet Recovery Flexcan (SERF) Board and Development Harness

The SERF Development Board for the PHD is intended as a development tool to simulate inputs and outputs when attached to a PHD display. The SERF Board is no longer supported for application development, and has been superseded by the PHD Development Harness, see section 8.2.3. This section has been retained for legacy support.

8.1. SERF Overview

The SERF Development Board allows the GPIO, CAN Bus, video and RS232 inputs and outputs to be easily accessed without having to make a custom wire harness or build a special I/O board for each development project. The SERF Development Board should be used in conjunction with the available Power and I/O cables for PHD displays. See Catalog MSG33-5024-US, PHD Accessories, for more information.

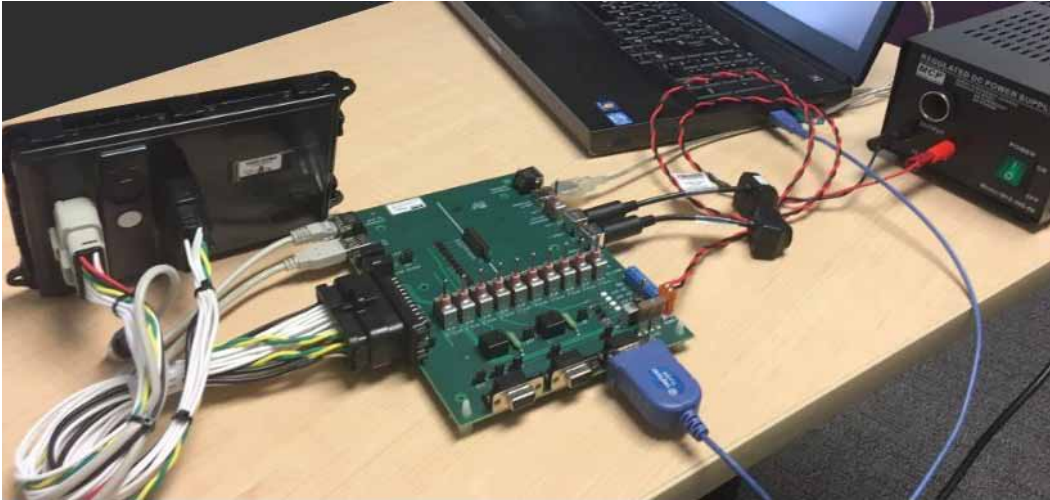

Figure 8.1. SERF Development Board connected to PHD

8.2. Available Inputs and Outputs

The SERF Development Board offers direct connectivity to the following Inputs and Outputs for the PHDs.

- 5VDC, 12VDC and Ground connections
- 12VDC or 24VDC Power Supply
- GPIO 1 through 10
- RS232 Communication
- CAN Bus 1 and 2
- CAN Bus 1 and 2 Termination Resistor
- Ethernet Communication (Reserved for Future Use)
- Audio L and R, Input and Output (Reserved for Future Use)

In addition to the above I/O, the SERF Development Board has pin locations and power supplies to add on a daughter board for matrix keypad or encoder inputs. The corresponding I/O is labeled on the SERF Development Board. Note that “External” indicates the connection from the PHD to an external device such as a PC, possibly through an adapter cable.

Below is an image of the SERF Development board. All the switches and ports are labeled. There are several jumpers to enable certain features.

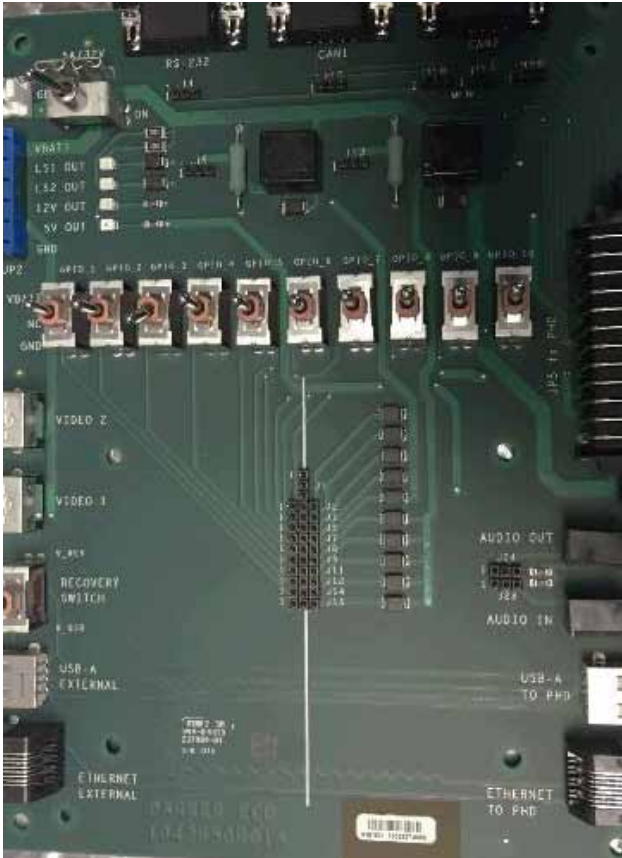

Figure 8.2. SERF board image showing labels

8.2.1. Switches and Connectors

The following table describes the corresponding ports and switches associated with each I/O.

PHD Switches and Connectors		
Name	Description	Usage Comments
PWR switch	Turns on and off power to the PHD, 9-32VDC	Power is supplied through JP1 connector. Turns on Power but cannot be used as a wake signal.
JP2 connector	Development connector	Connector is reserved for factory use
RS232 connector	Connector for RS232 communication to PC. Note: an adapter may be required.	Intended for output strings from Lua scripts. For debugging during development.
CAN 1 and 2 connector	Connector for CAN Communication to PC. Note: an adapter may be required.	Intended for tracing CAN messages or inserting CAN messages to the PHD for development.
GPIO_x switches	General Purpose I/O inputs.	Used to switch the GPIO to VBATT (high), GND (low) or floating state during development. Note: the corresponding jumpers must be positioned as shown in Jumper section.

PHD Switches and Connectors		
Name	Description	Usage Comments
JP5 connector	Multi pin connector to the PHD.	Main connector to the PHD connector(s).
Recovery switch	Connects USB_VBUS for Recovery, Programming, or Normal modes.	<p>Switch to V_RCV for recovery mode (>+6Vdc). Switch to V_USB (+5Vdc) to program PHD28 and PHD70. Leave in Neutral to program PHD50 and for normal operation.</p> <p>Recovery Switch Operation:</p> <ol style="list-style-type: none"> 1. With the Power Switch OFF, Place Recovery Switch in neutral position. 2. Power up the PHD. 3. Place the recovery switch in V_USB position. 4. Send the application file. 5. PHD should reboot in about 20-30 seconds after the file is sent. <p>Keep the Recovery Switch in neutral position for normal boot mode. The V_RCV position is for factory use only.</p>
Video 1 and 2 connector	Connector for analog cameras.	Used to provide video input from the analog camera to the PHD.
Audio 1 and 2 Connector	Connector for audio input and output for the audio.	Not enabled on the Standard products, intended for future use.
USB external	Connector for USB to PC or memory stick.	Intended for application downloads from a PC or USB memory stick in development.
USB to PHD	Connector for USB to the PHD.	Intended for application downloads from a PC or USB memory stick in development.
Ethernet external	Connector for Ethernet connection to PC, gateway or bridge.	Not enabled on the Standard products, intended for future use.
Ethernet to PHD	Connector for Ethernet to the PHD.	Not enabled on the Standard products, intended for future use.

8.2.2. Jumpers

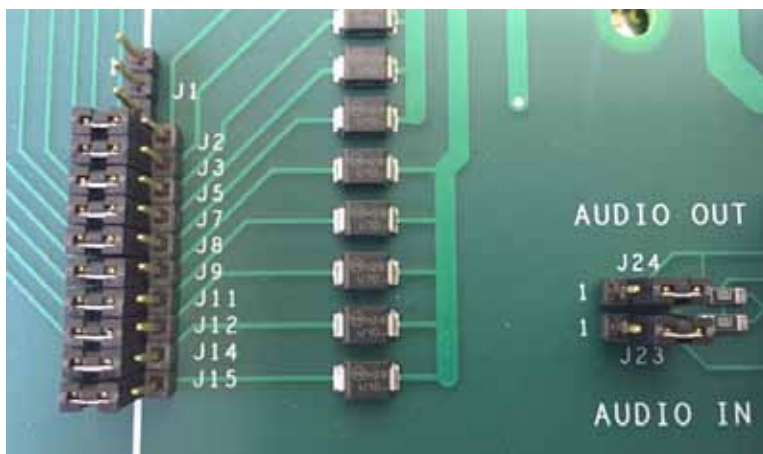

Figure 8.3. GPIO and audio jumpers

The following table describes the corresponding jumpers associated with each I/O:

PHD GPIO and Audio Jumpers			
Name	Description	Jumper Position Pins	Usage Comments
J1	Daughter board power	Removed	Pin 1, 12 Vdc Power
		Removed	Pin 2, 5 Vdc Power
		Removed	Pin 3, GND
J2	GPIO_10	1 to 2	Enable GPIO switch input.
		2 to 3	Intended for factory use.
		Removed	Enable daughter board input.
J3	GPIO_9	1 to 2	Enable GPIO switch input.
		2 to 3	Intended for factory use.
		Removed	Enable daughter board input.
J5	GPIO_8	1 to 2	Enable GPIO switch input.
		2 to 3	Intended for factory use.
		Removed	Enable daughter board input.
J7	GPIO_7	1 to 2	Enable GPIO switch input.
		2 to 3	Intended for factory use.
		Removed	Enable daughter board input.
J8	GPIO_6	1 to 2	Enable GPIO switch input.
		2 to 3	Intended for factory use.
		Removed	Enable daughter board input.
J9	GPIO_5	1 to 2	Enable GPIO switch input.
		2 to 3	Intended for factory use.
		Removed	Enable daughter board input.
J11	GPIO_4	1 to 2	Enable GPIO switch input.
		2 to 3	Intended for factory use.
		Removed	Enable daughter board input.
J12	GPIO_3	1 to 2	Enable GPIO switch input.
		2 to 3	Intended for factory use.
		Removed	Enable daughter board input.
J14	GPIO_2	1 to 2	Enable GPIO switch input.
		2 to 3	Intended for factory use.
		Removed	Enable daughter board input.
J15	GPIO_1	1 to 2	Enable GPIO switch input.
		2 to 3	Intended for factory use.
		Removed	Enable daughter board input.
J23	Audio 1	1 to 2	Not enabled on the Standard products, intended for future use.
		2 to 3	Not enabled on the Standard products, intended for future use.
J24	Audio 2	1 to 2	Not enabled on the Standard products, intended for future use.
		2 to 3	Not enabled on the Standard products, intended for future use.

Note: a daughter board with a matrix style keypad or encoder can be connected to J1 through J12.

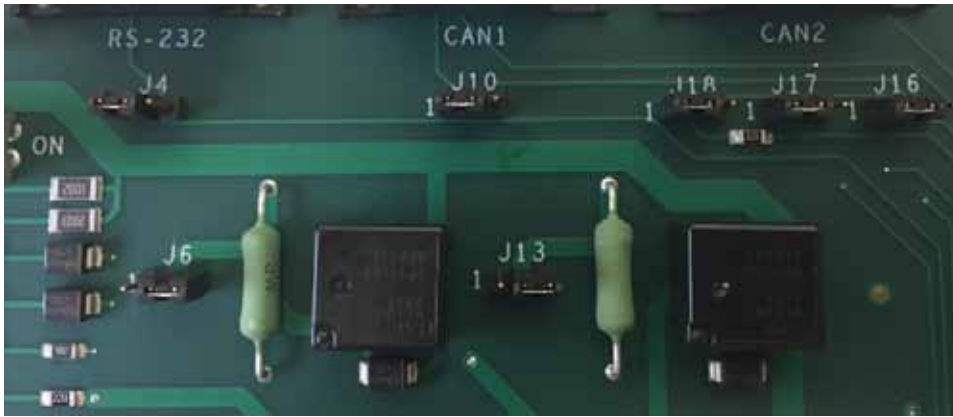

Figure 8.4. Power and communication jumpers

The following table describes the corresponding jumpers associated with power and communication:

PHD Power and Communication Jumpers			
Name	Description	Jumper Position Pins	Usage Comments
J4	RS232	1 to 2	Enable RS232 Input from RS232 Connector
		2 to 3	Intended for factory use
J6	External power supply	1 to 2	For 12Vdc (nom.) power supply.
		2 to 3	For 24Vdc (nom.) power supply.
J10	CAN 1 termination	1 to 2	Disconnect internal termination resistor to CAN 1.
		2 to 3	Connect internal termination resistor to CAN 1.
J13	External power supply	1 to 2	For 12Vdc (nom.) power supply.
		2 to 3	For 24Vdc (nom.) power supply.
J16	CAN 2 high	1 to 2	Connects CAN 1 high to CAN 2 high.
		2 to 3	Disconnects CAN 1 high to CAN 2 high.
J17	CAN 2 low	1 to 2	Connects CAN 1 low to CAN 2 low.
		2 to 3	Disconnects CAN 1 low to CAN 2 low.
J18	CAN 2 termination	1 to 2	Disconnect external termination resistor to CAN 2.
		2 to 3	Connect internal termination resistor to CAN 2.

8.2.3. PHD development harness

If simulating the I/O isn't required, the PHD Development Harness is a simpler, more robust option for application development. The cable contains Power, CAN, video, USB and serial connections for application development, but all contained in the harness itself. See Catalog MSG33-5024-US, PHD Accessories, for more information.



Figure 8.5. PHD development harness

PWR/GND Development Harness Inputs and Outputs include:

- 12VDC Power Output and Ground connections
- 12VDC/24VDC Power Supply and Ground
- RS232 Communication (UART)
- CAN Bus 1 and 2
- USB Type A Connection
- Video 1 and 2
- Recovery Switch*

*Keep the Recovery Switch in neutral or USB position for normal boot mode. The RCY position is for factory use only. Leave in Neutral to program PHD50 and in the USB position to program the PHD28 and PHD70.



Figure 8.6. Recovery switch

8.2.4. DB9 Pinout Reference

Both the CAN connector on the SERF board and the RS232 connectors on either interface use standard DB9 connectors for ease of use. Most of the common adapters for either RS232 or CAN that are required to interface with a PC offer this connection type.

The following table shows the pin outs for each of the DB9 connectors:

CAN		RS232	
Pin	Description	Pin	Description
1	No connect	1	No connect
2	CAN L	2	TX (transmit)
3	No connect	3	RX (receive)
4	No connect	4	No connect
5	Shield	5	GND (signal ground)
6	No connect	6	No connect
7	CAN H	7	No connect
8	No connect	8	No connect
9	No Connect	9	No connect

RS232 settings: Baud rate 115200, 8 data bits, no parity, 1 stop bit.

8.2.5. USB Cabling

USB cabling must follow the USB Specifications, with proper shielding for the application. Good shielding is required to help ensure proper communication between the PC and the PHD display. Improper shielding can result in the PC not being able to identify the PHD device when it is plugged into the PC. This may result in an error showing that an unknown device has been plugged in and a driver should be installed. Do not attempt to directly install a new driver, the correct driver for the PHD USB communication is installed when the PHD Packager software is installed. Since shielding is critical to the proper operation of the USB function, Parker recommends only commercially purchased cables.

9. Mounting the PHD

To mount the PHD into a vehicle mounting panel,

1. Install the PHD from the front.
2. Ensure that:
 - the PHD is oriented to the operator's viewing angle
 - the wire harness connects easily to the connectors and that the bend radius is adequate
 - the harness is shielded from harsh impact
3. Secure the PHD using 4 screws or metal spring clips.
4. Install the bezel, typically provided by the customer (Parker does sell a snap-on cosmetic bezel as an optional accessory).

The PHD may also be mounted from the rear of the panel without a bezel for a flush appearance using insert studs and nuts.

Drawings and other documents may be found at www.parker.com/ecd or contact your Parker representative.

9.1. Dimensions

The dimensions for each of the PHD family of displays is provided below.

9.1.1. PHD28

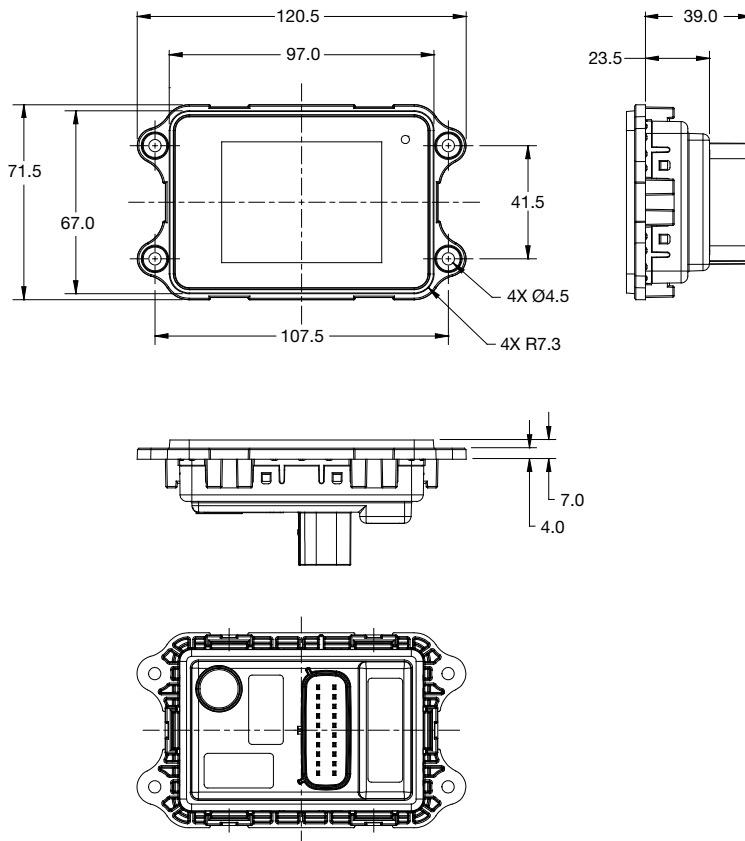

Figure 9.1. PHD28 dimensions (mm)

Refer to the PHD28 drawings for panel cut-out dimensions.

9.1.2. PHD50

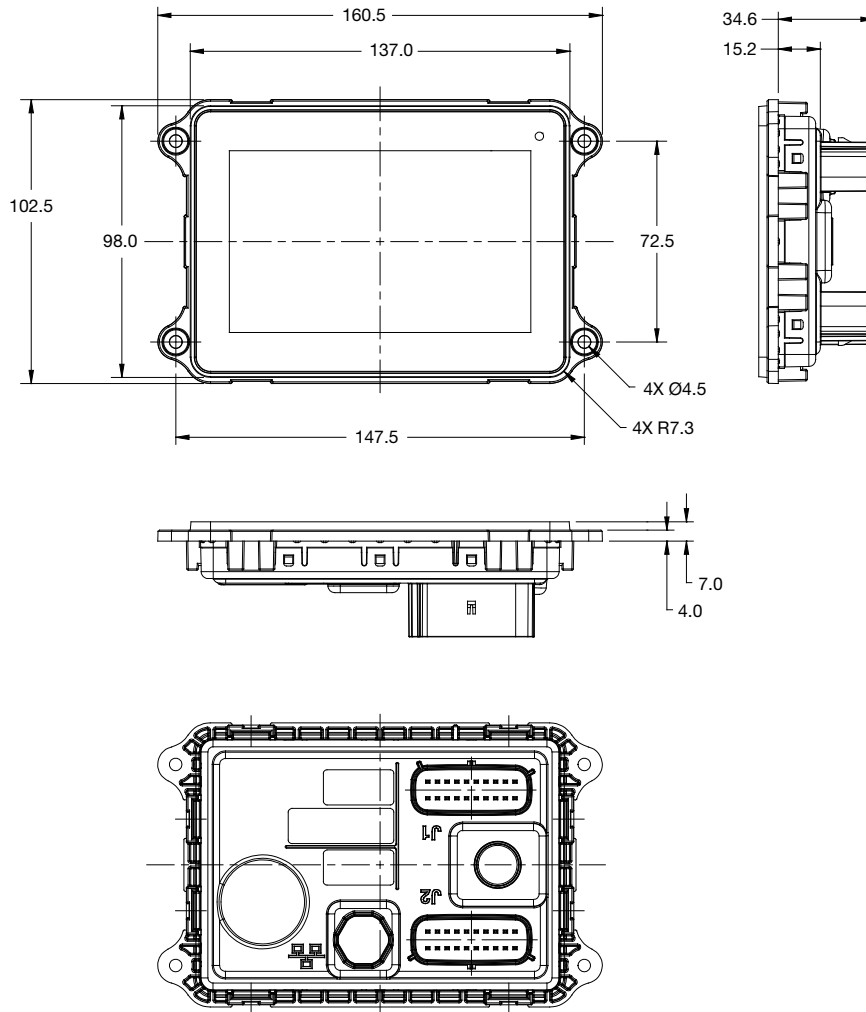

Figure 9.2. PHD50 dimensions (mm)

Refer to the PHD50 drawings for panel cut-out dimensions.

9.1.3. PHD70

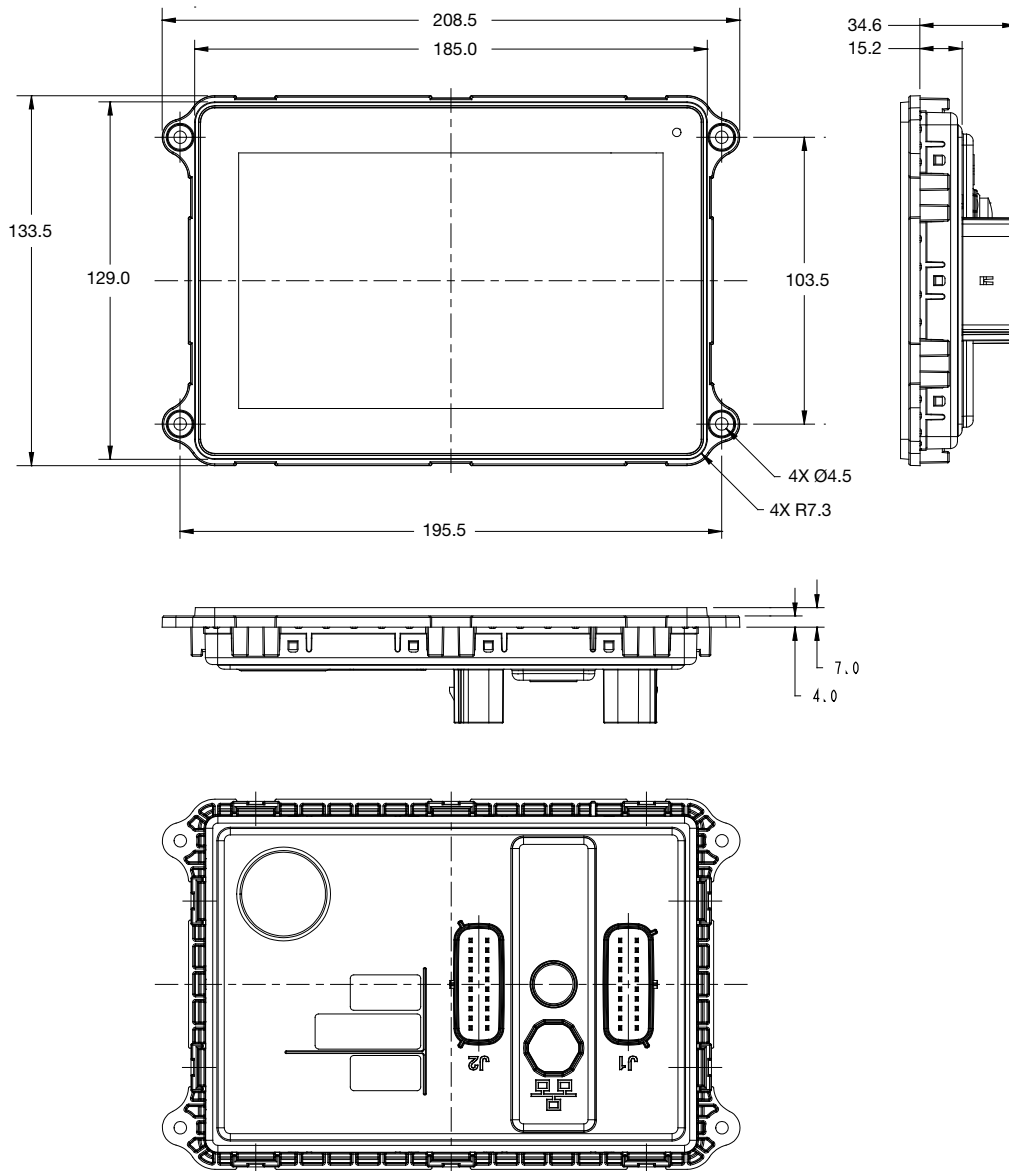

Figure 9.3. PHD70 dimensions (mm)

Refer to the PHD70 drawings for panel cut-out dimensions.

10. Understanding PHD software

The PHD family of displays is a versatile product suitable for any machine where a visual HMI for the operator is desired. This manual does not cover how to create software for the PHD, please refer to the separate PHD API User Manual.

There are a number of ways to create software for this product.

- Configuration of CAN messages and the PHD local I/O is done using Lua script and API calls.
- Creation of display pages and their functionality is performed using Crank Storyboard software. A Crank license is required to create display pages.

Contact your Parker Account Representative for more details about creating software for the PHD.

11. Environmental Protection

The PHD family is manufactured to meet stringent industry standards. A summary of tested specifications is listed below. More complete information (severity/duration) of tests will be included in future editions. Please contact your Parker Vansco representative for more details..

11.1. EMI

- J1455 Section 4.13.1, Over voltage
- J1455 Section 5.10.3, Reverse polarity
- J1455 Section 5.10.4, Short circuit
- ISO 7637 Section 5.6.x, EP455 Section 5.11.x, Transients
- ISO 14982, EMC emissions
- ISO 14982, EMC susceptibility

11.2. Mechanical environment

- BS EN7691 Section 6.6.1, Random vibration
- EP455 Section 4.11.3.1, Drop test

11.3. ESD

- EN61000-4-2, Surface and connectors

11.4. Climate environment

- IEC 60529 Section 14.2.5, Water (IP65)
- IEC 68-2-5, UV exposure
- IEC 68-2-2 Section 4, High temperature
- IEC 68-2-1 Section 2, Low temperature
- EP455 Section 5.1.1, Temperature cycle
- J1455 Section 4.1.3.2, Temperature shock
- EP455 Section 5.13.2, Humidity soak
- EP455 Section 4.3.2, Humidity cycle

11.5. Chemical environment

- MIL_STD 202G M101E-A, Salt spray
- ASAE EP455 Section 5.8.2, Chemical exposure - brush



Parker Hannifin Canada
Electronic Motion and Controls Division
1305 Clarence Avenue Winnipeg, MB,
R3T 1T4 Canada
phone 204 452 6776
www.parker.com/emc