

<b>CV</b>	Check Valves
<b>SH</b>	Shuttle Valves
<b>LM</b>	Load/Motor Controls
<b>FC</b>	Flow Controls
<b>PC</b>	Pressure Controls
<b>LE</b>	Logic Elements
<b>DC</b>	Directional Controls
<b>MV</b>	Manual Valves
<b>SV</b>	Solenoid Valves
<b>PV</b>	Proportional Valves
<b>CE</b>	Coils & Electronics
<b>CB</b>	Cartridge Bodies
<b>BC</b>	Bodies & Cavities
<b>TD</b>	Technical Data

## General Description

2 Way, Normally Open, Proportional Poppet Valve. For additional information see Technical Tips on pages PV1-PV5.

## Features

- Adjusted at factory for low variation
- Coil: Waterproof, hermetically sealed, requires no O'Rings; Symmetrical coil can be reversed without affecting performance.
- Industry common cavity
- External surfaces plated
- Excellent low flow metering capability

## Specifications

All performance data with CAS coil.  
 Maximum current, 70% recommended.  
 Hydraulic oil 150 SSU @ 40°C (32 cSt)

Rated Flow @ 70% of Full Current at $\Delta P$ 34.5 Bar (500 PSI)	117 LPM (31 GPM)
Maximum Input Pressure at Port 2	210 Bar (3000 PSI)
Minimum Pressure Differential	21 Bar (300 PSI)
Maximum Internal Leakage	5 drops/min. (.33 cc/min.) @ 210 Bar (3000 PSI)
Hysteresis @ 100 Hz PWM	<15% NOTE: Current regulated PWM recommended
Cartridge Material	All parts steel. All operating parts hardened steel.
Operating Temp. Range/Seals	-34°C to +121°C (Nitrile) (-30°F to +250°F) -26°C to +204°C (Fluorocarbon) (-15°F to +400°F)
Fluid Compatibility/Viscosity	Mineral-based or synthetic with lubricating properties at viscosities of 45 to 2000 SSU (6 to 420 cSt)
Filtration	ISO-4406 18/16/13, SAE Class 4
Approx. Weight	0.41 kg (0.90 lbs.)
Cavity	C16-2 (See BC Section for more details)

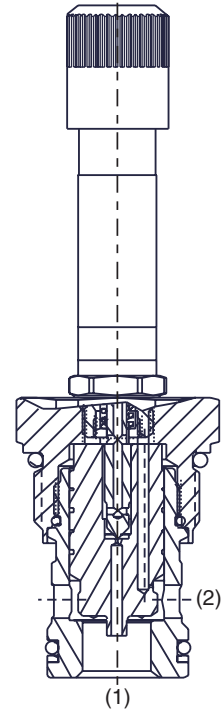
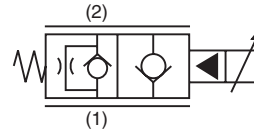

## Performance Curves

### Flow vs. Input Current

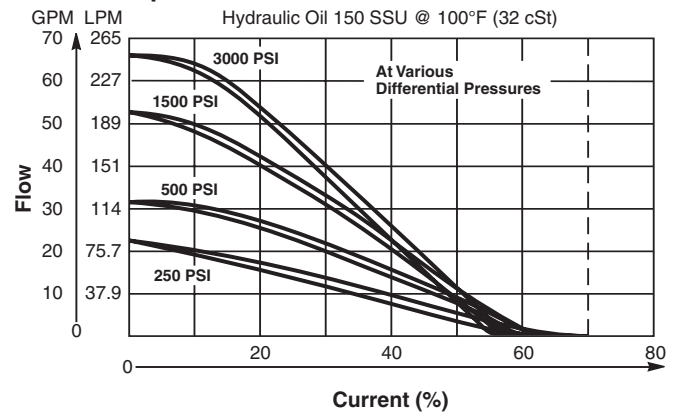

### Pressure Drop vs. Flow (Through cartridge only)

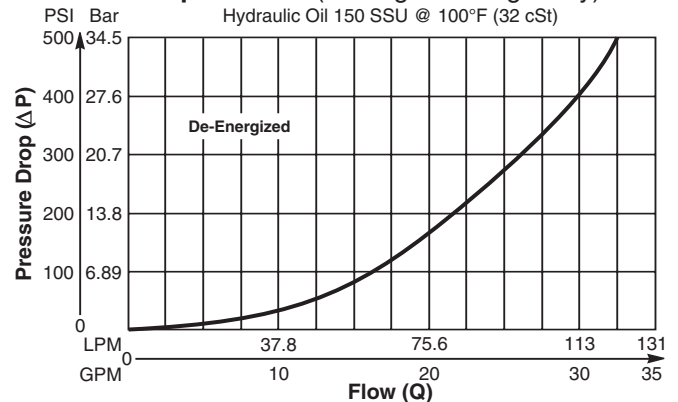

**Dimensions** Millimeters (Inches)

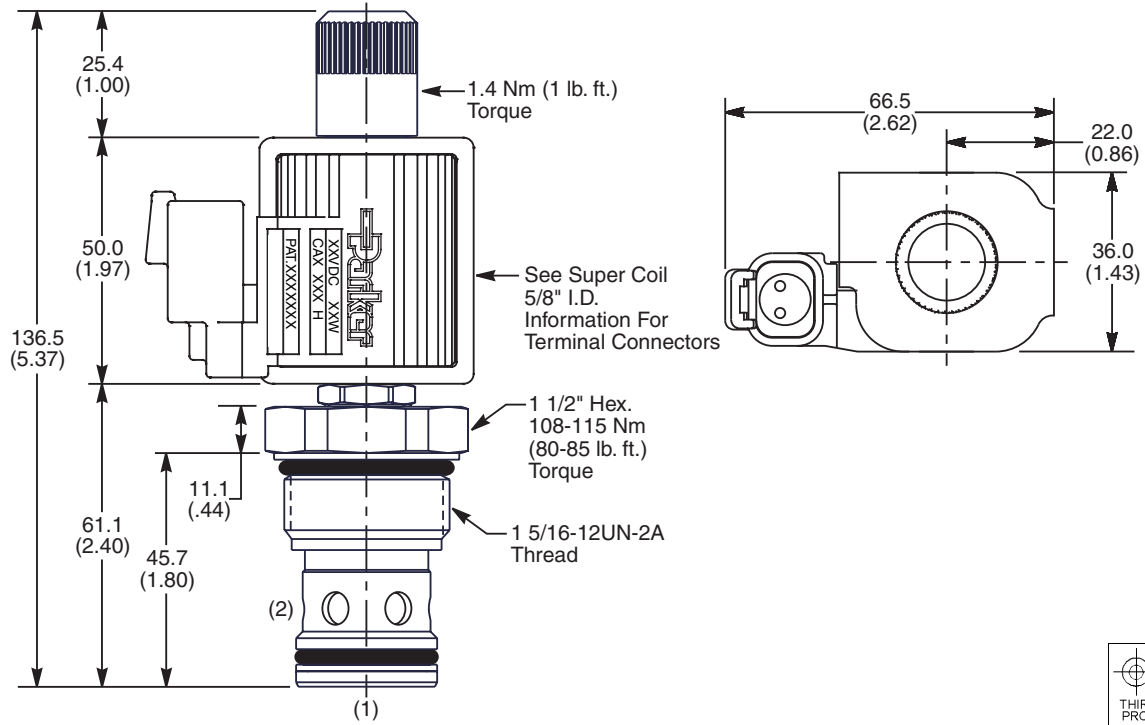

**Ordering Information**

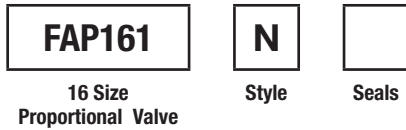

**Highlighted** represents preferred options that offer the shortest lead times. Other options may be available, but at extended lead times.

**Coil(s) sold separately.** Please see section CE of this catalog, 5/8" Coil (CA series), for ordering information.

Code	Style
N	Normally Open

Code	Seals / Kit No.
N	Nitrile / Buna-N (SK16-2)
V	Fluorocarbon / (SK16-2V)

Order Bodies Separately  
 See section BC

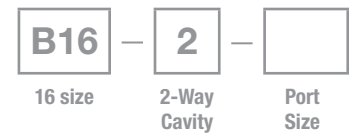

Code	Porting / Body Material
16T	SAE-16 / Steel (5000 PSI)
A16T	SAE-16 / Aluminium (3000 PSI)

- CV Check Valves
- SH Shuttle Valves
- LM Load/Motor Controls
- FC Flow Controls
- PC Pressure Controls
- LE Logic Elements
- DC Directional Controls
- MV Manual Valves
- SV Solenoid Valves
- PV Proportional Valves
- CE Coils & Electronics
- CB Carpak Bodies
- BC Bodies & Cavities
- TD Technical Data