

CV	Check Valves
SH	Shuttle Valves
LM	Load/Motor Controls
FC	Flow Controls
PC	Pressure Controls
LE	Logic Elements
DC	Directional Controls
MV	Manual Valves
SV	Solenoid Valves
PV	Proportional Valves
CE	Coils & Electronics
CB	Cartridge Bodies
BC	Bodies & Cavities
TD	Technical Data

General Description

2 Way, Normally Open, Proportional Poppet Valve. For additional information see Technical Tips on pages PV1-PV5.

Features

- One piece cartridge housing ensures internal concentricity
- Adjusted at factory for low variation
- Coil: Waterproof, hermetically sealed, requires no O’Rings; Symmetrical coil can be reversed without affecting performance.
- Industry common cavity
- External surfaces plated
- Excellent low flow metering capability

Specifications

All performance data with CAS coil.
 Maximum current, 70% recommended.
 Hydraulic oil 150 SSU @ 40°C (32 cSt)

Rated Flow @ 70% of Full Current at ΔP 34.5 Bar (500 PSI)	55 LPM (14.5 GPM)
Maximum Input Pressure at Port 2	210 Bar (3000 PSI)
Minimum Pressure Differential	21 Bar (300 PSI)
Maximum Internal Leakage	5 drops/min. (.33 cc/min.) @ 210 Bar (3000 PSI)
Hysteresis @ 100 Hz PWM	<15% NOTE: Current regulated PWM recommended
Cartridge Material	All parts steel. All operating parts hardened steel.
Operating Temp. Range/Seals	-37°C to +93°C (“D”-Ring) (-35°F to +200°F) -34°C to +121°C (Nitrile) (-30°F to +250°F) -26°C to +204°C (Fluorocarbon) (-15°F to +400°F)
Fluid Compatibility/Viscosity	Mineral-based or synthetic with lubricating properties at viscosities of 45 to 2000 SSU (6 to 420 cSt)
Filtration	ISO-4406 18/16/13, SAE Class 4
Approx. Weight	0.23 kg (0.52 lbs.)
Cavity	C10-2 (See BC Section for more details)

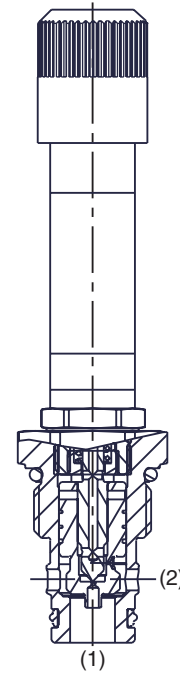
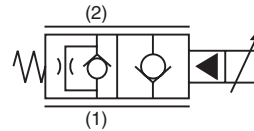

Performance Curves

Flow vs. Input Current

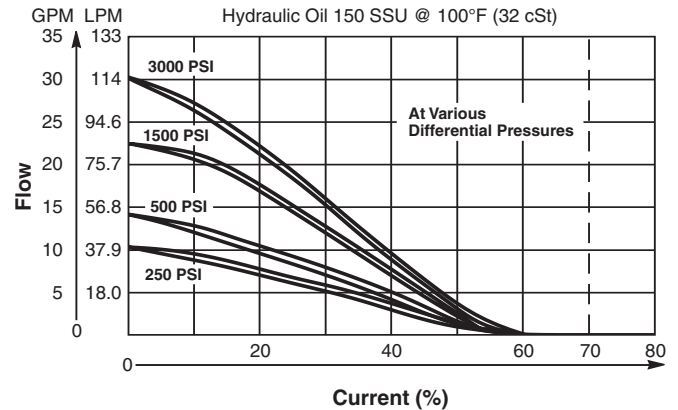

Pressure Drop vs. Flow (Through cartridge only)

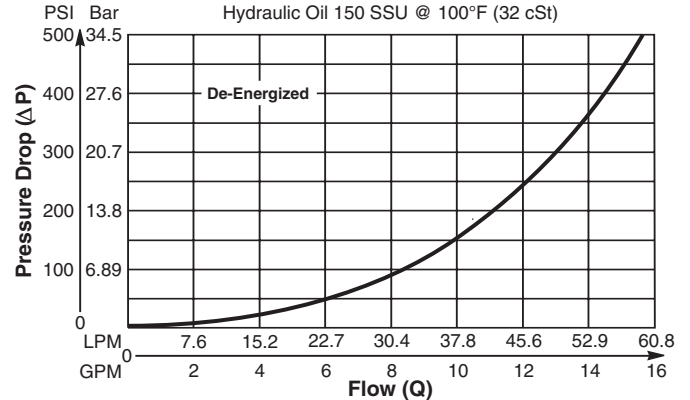

Dimensions Millimeters (Inches)

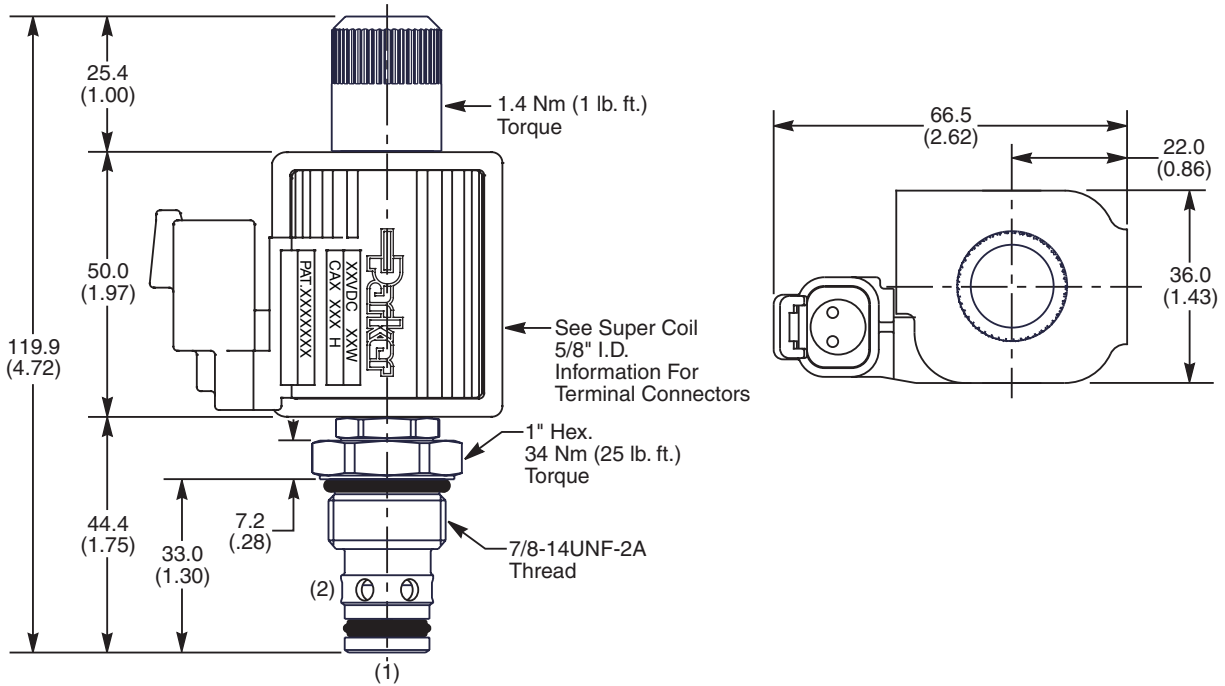

Ordering Information

FAP101	N	
10 Size Proportional Valve	Style	Seals

Highlighted represents preferred options that offer the shortest lead times. Other options may be available, but at extended lead times.

Coil(s) sold separately. Please see section CE of this catalog, 5/8" Coil (CA series), for ordering information.

Code	Style
N	Normally Open

Code	Seals / Kit No.
Omit	"D"-Ring / (SK10-2)
N	Nitrile / Buna-N (SK10-2)
V	Fluorocarbon / (SK10-2V)

Order Bodies Separately
 See section BC

B10	2	
10 size	2-Way Cavity	Port Size

Code	Porting / Body Material
8T	SAE-8 / Steel (5000 PSI)
A8T	SAE-8 / Aluminium (3000 PSI)

CV
Check Valves
SH
Shuttle Valves
LM
Load/Motor Controls
FC
Flow Controls
PC
Pressure Controls
LE
Logic Elements
DC
Directional Controls
MV
Manual Valves
SV
Solenoid Valves
PV
Proportional Valves
CE
Coils & Electronics
CB
Cartrpak Bodies
BC
Bodies & Cavities
TD
Technical Data