

General Description

Threaded Cartridge Style Counterbalance Valve. Pilot assisted, designed for motion control applications. For additional information see Technical Tips on pages LM1-LM4.

Features

- Poppet construction for minimal leakage
- Incorporates direct acting relief valve for overload protection
- Includes reverse check valve within body, saving space and minimizing installation cost
- Fully sealed pilot for high efficiency and accurate pilot ratio
- Three pilot ratios available, 1.5 : 1, 3 : 1, and 4.5 : 1
- Hardened working parts for maximum durability
- All external parts zinc plated

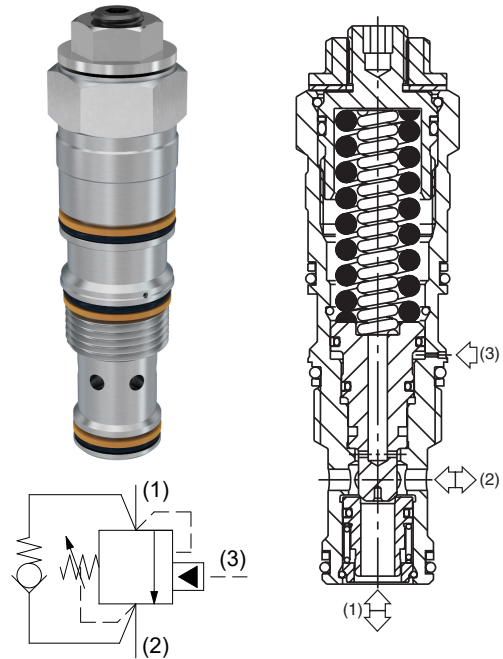

Specifications

Rated Flow	60 LPM (16 GPM)
Pressure	40-350 Bar (580-5000 PSI)
Sensitivity: Pressure/Turn	104 Bar (1508 PSI)
Pilot Ratio	E2E1 - 1.5 : 1 E2K1 - 3 : 1 E2M1 - 4.5 : 1
Leakage at 150 SSU (32 cSt)	5 drops/min. (.33cc/min) @ 75% of thermal crack pressure
Cartridge Material	All parts steel. All operating parts hardened steel.
Operating Temp. Range/Seals	-34°C to 121°C(Nitrile) (-30°F to 250°F) -26°C to 204°C(Fluorocarbon) (-15°F to +400°F)
Fluid Compatibility/ Viscosity	Mineral-based or synthetic with lubricating properties at viscosities of 45 to 2000 SSU (6 to 420 cSt)
Filtration	ISO-4406 18/16/13, SAE Class 4
Approx. Weight	0.17 kg (0.37 lbs.)
Cavity	CAVT11A (See BC Section for more details)

Performance Curves

Relief Performance 1 to 2

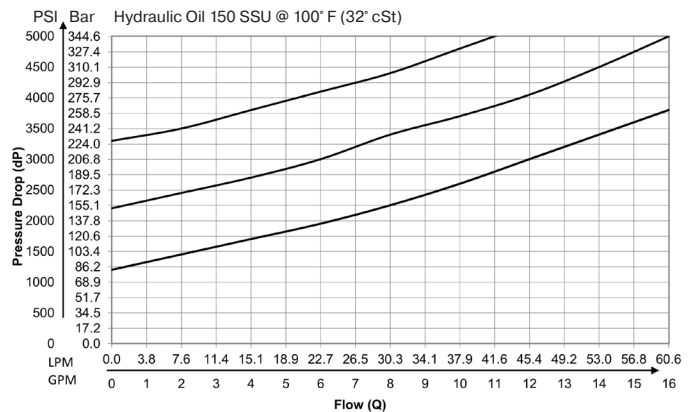

Pressure Drop vs Flow

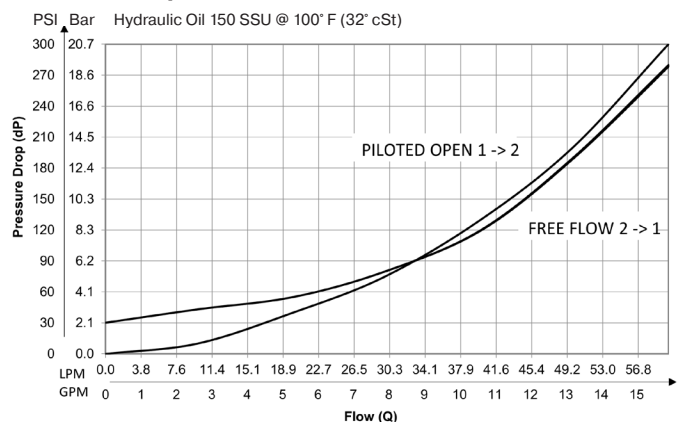

Required Pilot Pressure Calculation

$$P_3 = P_2 * \left(\frac{1}{P_R} + 1 \right) + \left(\frac{P_C - P_1}{P_R} \right)$$

P_3 = Pilot Pressure
 P_1 = Cylinder (Load) Pressure
 P_2 = Valve (System) Pressure
 P_C = Crack Pressure Setting
 P_R = Pilot Ratio

Dimensions Millimeters (Inches)

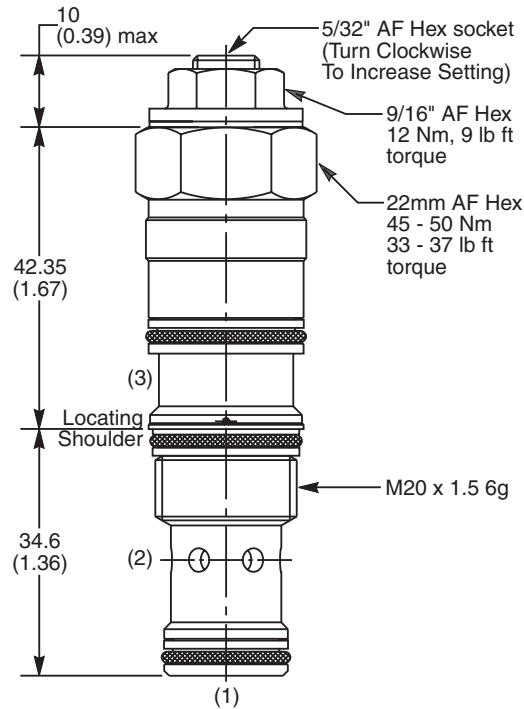

Ordering Information

E2		1			
Load Control Valve	Pilot Ratio	Adjustment Style	Cracking Pressure	Seals	

Highlighted represents preferred options that offer the shortest lead times. Other options may be available, but at extended lead times.

Code	Pilot Ratio
E	1.5 : 1
K	3 : 1
M	4.5 : 1

Code	Cracking Pressure
	Omit for no setting (Standard)*

*Standard valve is set to crack at 215 Bar (3120 PSI). Valve to be set to 1.3 times maximum load induced pressure.

Order Bodies Separately

LB10		
Line Body	Porting	Body Material

Code	Adjustment Style / Kit No.
Z	Screw Adjust (Standard)
T	Tamper Resistant (TC1125)

Code	Seals / Kit No.
N	Nitrile, Buna-N (Std.) / (SK30008N-1)
V	Fluorocarbon / (SK30700V-1)

Code	Porting
825	1/2" SAE (main) 1/4" SAE (aux)

Code	Body Material
S	Steel