

Technical Information

- CV** Check Valves
- SH** Shuttle Valves
- LM** Load/Motor Controls
- FC** Flow Controls
- PC** Pressure Controls
- LE** Logic Elements
- DC** Directional Controls
- MV** Manual Valves
- SV** Solenoid Valves
- PV** Proportional Valves
- CE** Coils & Electronics
- BC** Bodies & Cavities
- TD** Technical Data

General Description

Solenoid Operated Unloading Relief Valve. For additional information see Technical Tips on page PC4.

Features

- Two functions in one valve, unloading and relieving
- Factory set relief pressure or adjustable option
- Integral 250 micron pilot flow filter
- Coil: Waterproof, hermetically sealed, requires no O'Rings; Symmetrical coil can be reversed without affecting performance.
- Valve is normally open

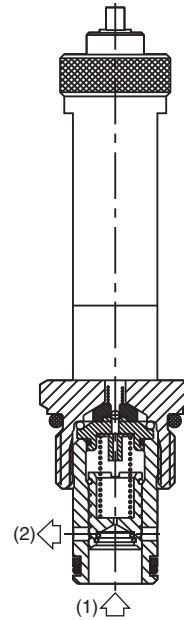
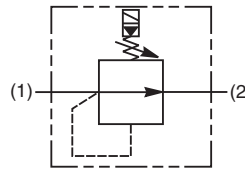

Specifications

Rated Flow (At 70 PSI ΔP)	60 LPM (16 GPM)
Max. Pressure	6.9 - 276 Bar (100 - 4000 PSI)
Reseat Pressure 200 Hz PWM	90% of Cracking Pressure
Max. Tank Pressure	70 Bar (1000 PSI)
Cartridge Material	All parts steel. All operating parts hardened steel.
Operating Temp. Range/Seals	-34°C to +121°C (Nitrile) (-30°F to +250°F) -26°C to +204°C (Fluorocarbon) (-15°F to +400°F)
Fluid Compatibility/ Viscosity	Mineral-based or synthetic with lubricating properties at viscosities of 45 to 2000 SSU (6 to 420 cSt)
Filtration	ISO-4406 18/16/13, SAE Class 4
Approx. Weight	.45 kg (.98 lbs.)
Cavity	C10-2 (See BC Section for more details)

Performance Curves

Pressure Drop vs. Flow

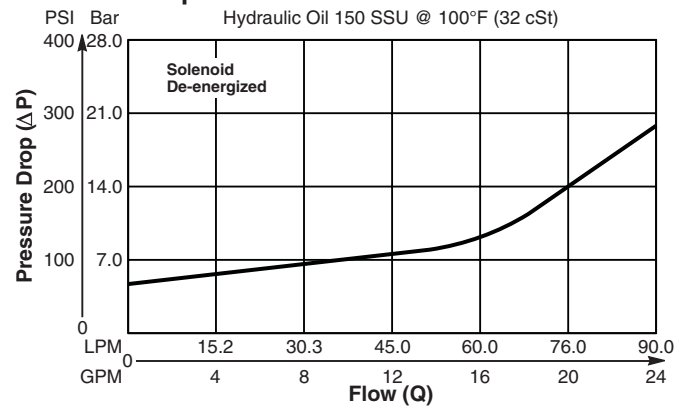

Pressure Drop vs. Flow - Relieving Performance

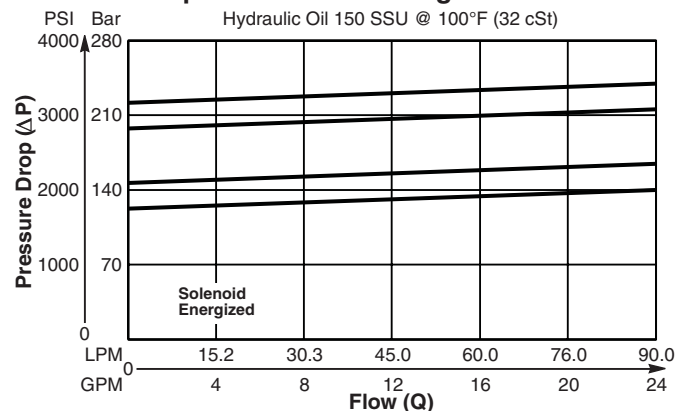

Dimensions Millimeters (Inches)

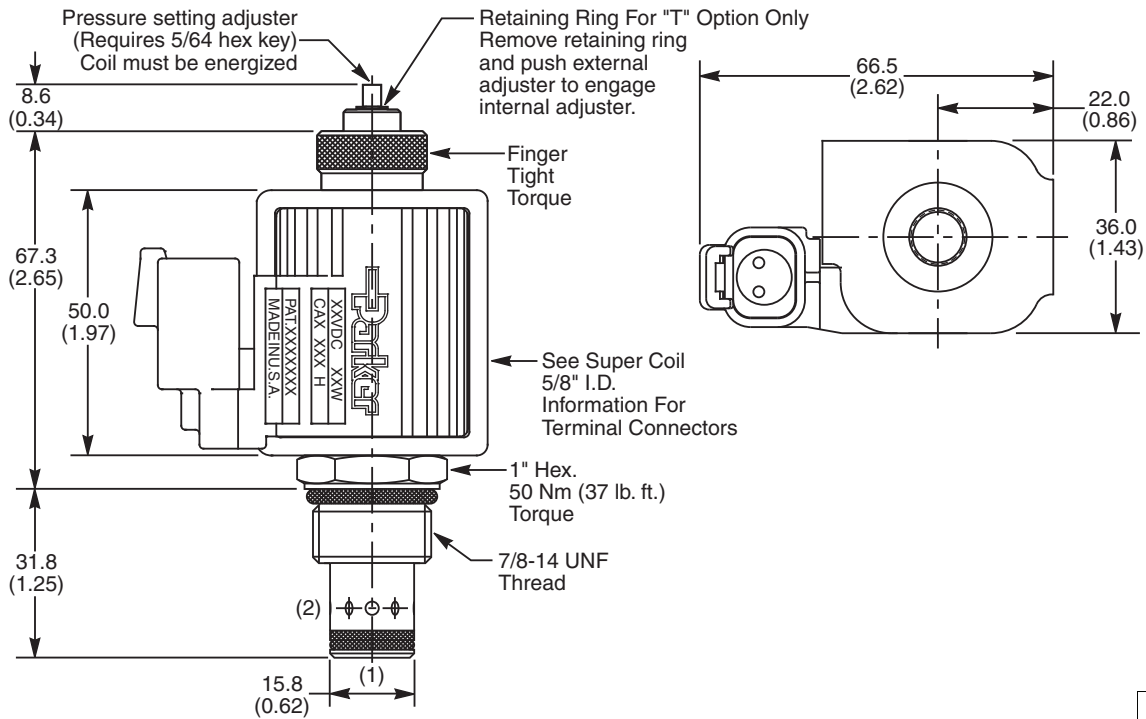

Ordering Information

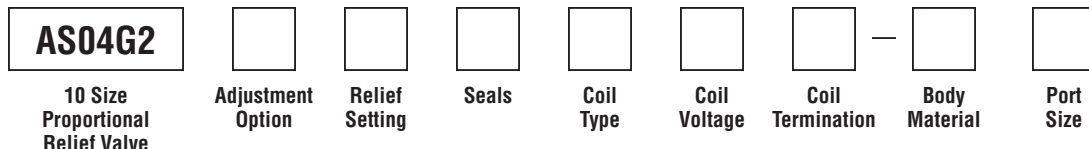

Code	Adjustment Options
T	Tamper Proof
Z	Push and Turn*

* Allows for fine tuning of pressure setting.

Code	Seals / Kit. No.
N	Nitrile / Buna-N (Std.) (SK30503N-1)
V	Fluorocarbon / (SK30503V-1)

Code	Coil Voltage
Omit	Without Coil
D012	12 VDC
D024	24 VDC
A120	120 VAC, 60/50 Hz

Code	Body Material
Omit	Steel
A	Aluminum

Code	Relief Setting
Omit	124 Bar (1800 PSI) Standard
14	140 Bar (2000 PSI)
20	200 Bar (2900 PSI)
22	220 Bar (3200 PSI)
27	276 Bar (4000 PSI)

Code	Coil Type
Omit	Without Coil
SP	Super Coil - 28 Watts

Code	Coil Termination
Omit	Without Coil
A	Amp Jr. Timer*
D	DIN Plug Face
H	Molded Deutsch*
L	Dual Lead Wire*
PF	Packard Female*
PM	Packard Male*
S	Dual Spade*

Code	Port Size	Body Part No.
Omit	Cartridge Only	
6T	SAE-6	(B10-2-*6T)
8T	SAE-8	(B10-2-*8T)

* Add "A" for aluminum, omit for steel.

See Super Coil 5/8" I.D.
 *DC Only