

Technical Information

- CV Check Valves
- SH Shuttle Valves
- LM Load/Motor Controls
- FC Flow Controls
- PC Pressure Controls
- LE Logic Elements
- DC Directional Controls
- MV Manual Valves
- SV Solenoid Valves
- PV Proportional Valves
- CE Coils & Electronics
- BC Bodies & Cavities
- TD Technical Data

**General Description**

Threaded Cartridge Style Counterbalance Valve. Pilot assisted, designed for motion control applications. For additional information see Technical Tips on pages LM1-LM4.

**Features**

- Spring chamber isolated from system backpressure by double seal, eliminating vent port leakage and need for separate drain line
- Poppet construction for minimal leakage
- Suitable for remote pilot controlled boomlock applications as per ISO8463
- Incorporates direct acting relief valve for overload protection
- Includes reverse check valve within body
- Hardened working parts for maximum durability
- Adjustable and tamper resistant versions available
- All external parts zinc plated

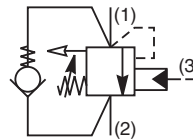
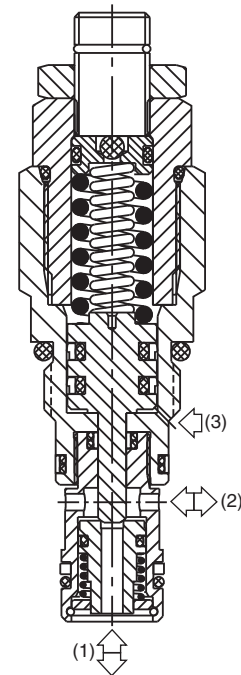
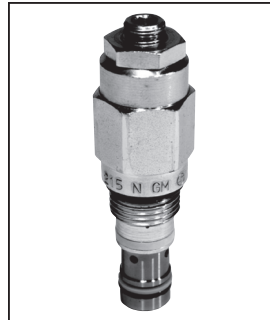

**Specifications**

<b>Rated Flow</b>	20 LPM (5.3 GPM)
<b>Pressure</b>	100 - 350 Bar (1450 - 5075 PSI)
<b>Sensitivity: Pressure/Turn</b>	114 Bar (1650 PSI)
<b>Pilot Ratio</b>	15 : 1
<b>Cartridge Material</b>	All parts steel. All operating parts hardened steel.
<b>Operating Temp. Range/Seals</b>	-34°C to +121°C (Nitrile) (-30°F to +250°F) -26°C to +204°C (Fluorocarbon) (-15°F to +400°F)
<b>Fluid Compatibility/Viscosity</b>	Mineral-based or synthetic with lubricating properties at viscosities of 45 to 2000 SSU (6 to 420 cSt)
<b>Filtration</b>	ISO-4406 18/16/13, SAE Class 4
<b>Approx. Weight</b>	0.08 kg (0.18 lbs.)
<b>Cavity</b>	53-1 (See BC Section for more details)

**Performance Curves**

**Relief & Pilot Performance 1 to 2**

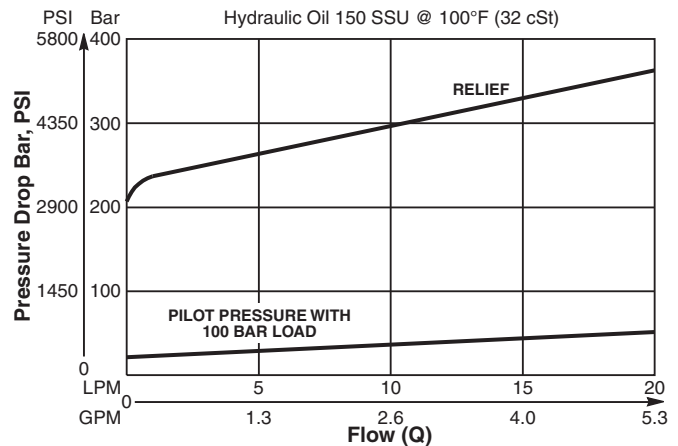

**Pressure Drop vs Flow**

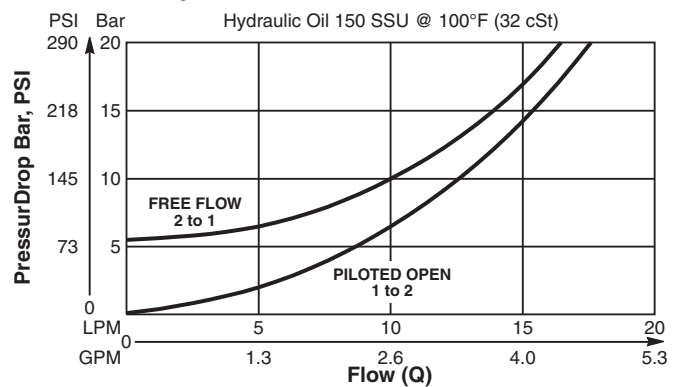

**Dimensions** Millimeters (Inches)

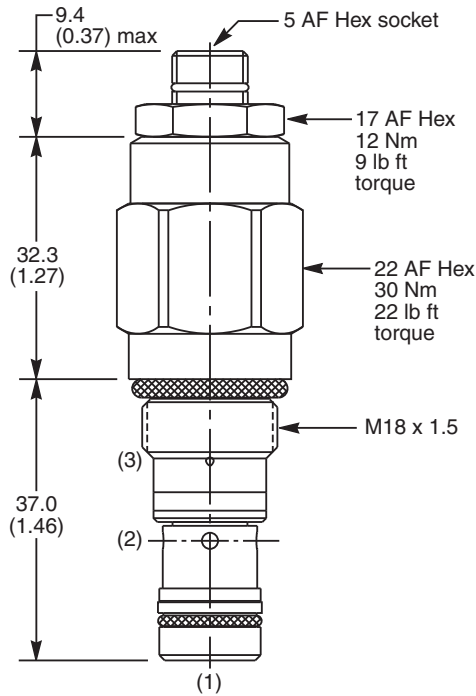

**Ordering Information**

<b>E6</b>	<b>K</b>	<b>020</b>	<input type="checkbox"/>	<input type="checkbox"/>	<input type="checkbox"/>
Load Control Valve	Pilot Ratio		Adjustment Style	Cracking Pressure	Seals

Code	Pilot Ratio
K	15 : 1

Code	Adjustment Style / Kit No.
Z	Screw Adjust (Standard)
T	Tamper Resistant (TC1125)

Code	Cracking Pressure
	Omit for no setting (Standard)* Specify setting if required

*\*Standard valve is set to crack at 215 Bar (3120 PSI). Valve to be set to 1.3 times maximum load induced pressure.*

Code	Seals / Kit No.
N	Nitrile, Buna-N (Std.) / (SK30087N-1)
V	Fluorocarbon / (SK30087V-1)

*Order Bodies Separately*

<b>LB10</b>	<input type="checkbox"/>	<input type="checkbox"/>
Line Body	Porting	Body Material

Code	Porting
318	3/8" SAE (main) 1/4" SAE (aux)
319	3/8" SAE Dual Cavity

Code	Body Material
A	Aluminum
S	Steel