

Technical Information

- CV** Check Valves
- SH** Shuttle Valves
- LM** Load/Motor Controls
- FC** Flow Controls
- PC** Pressure Controls
- LE** Logic Elements
- DC** Directional Controls
- MV** Manual Valves
- SV** Solenoid Valves
- PV** Proportional Valves
- CE** Coils & Electronics
- BC** Bodies & Cavities
- TD** Technical Data

Valve/Cavity Compatibility

For additional information see Technical Tips on pages BC1-BC6.

CAVITY	VALVE				
	Winner's Circle	Parker	Waterman	FPS	CEC
Winner's Circle	X	X	X		
Parker	X	X	X		
Waterman	X	X	X		
FPS					
CEC					X

Performance Curve
Pressure Drop vs. Flow

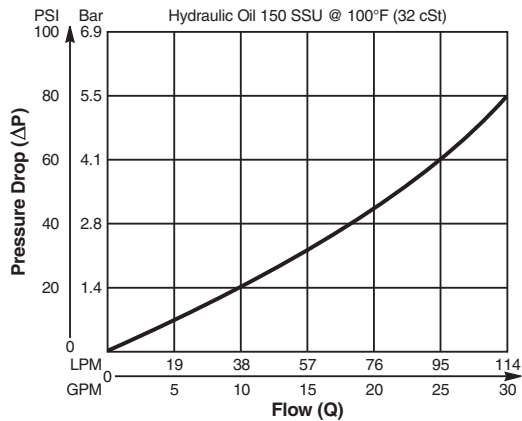

Dimensions Millimeters (Inches)

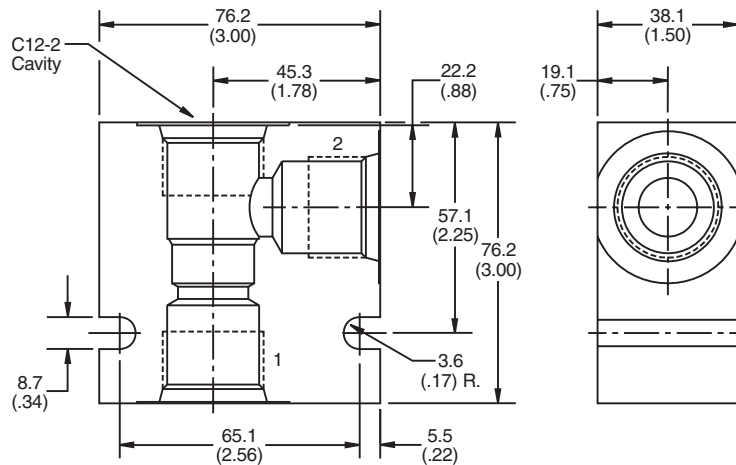
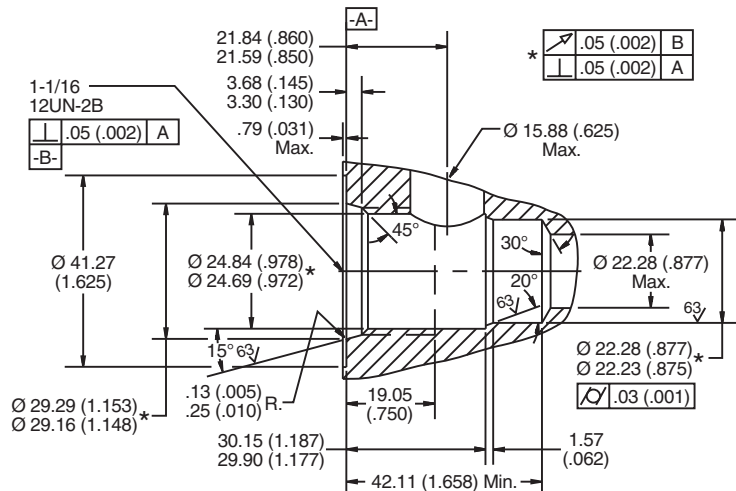

Ordering Information

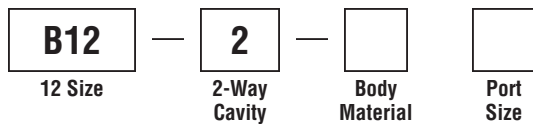

Code	Body Material
Omit	Steel
A	Aluminum

Code	Port Size
8T	SAE - 8
12T	SAE - 12

Form Tool: Rougher None
Finisher NFT12-2F
Weight: .45 kg (1.0 lbs.)