

Owner's Manual Power Take-Offs

Effective: March 15, 2015
Supersedes: HY25-1569-M1/US
November 15, 2013

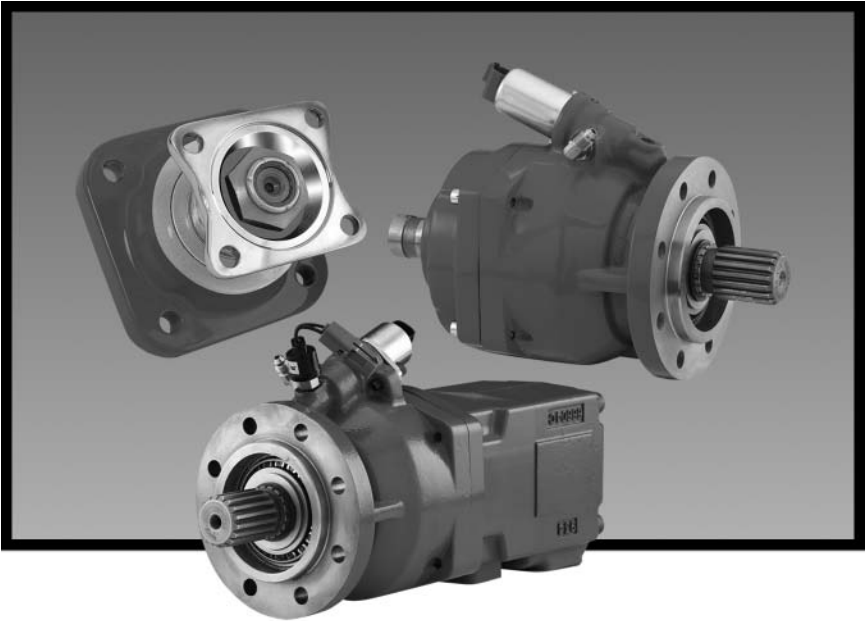

**CAT-D Series
CAT-H Series
560V Series**



WARNING — User Responsibility

FAILURE OR IMPROPER SELECTION OR IMPROPER USE OF THE PRODUCTS DESCRIBED HEREIN OR RELATED ITEMS CAN CAUSE DEATH, PERSONAL INJURY AND PROPERTY DAMAGE.

This document and other information from Parker-Hannifin Corporation, its subsidiaries and authorized distributors provide product or system options for further investigation by users having technical expertise.

The user, through its own analysis and testing, is solely responsible for making the final selection of the system and components and assuring that all performance, endurance, maintenance, safety and warning requirements of the application are met. The user must analyze all aspects of the application, follow applicable industry standards, and follow the information concerning the product in the current product catalog and in any other materials provided from Parker or its subsidiaries or authorized distributors.

To the extent that Parker or its subsidiaries or authorized distributors provide component or system options based upon data or specifications provided by the user, the user is responsible for determining that such data and specifications are suitable and sufficient for all applications and reasonably foreseeable uses of the components or systems.

Offer of Sale

The items described in this document are hereby offered for sale by Parker Hannifin Corporation, its subsidiaries or its authorized distributors. This offer and its acceptance are governed by the provisions stated in the "Offer of Sale".

Patent Information

The Chelsea® Power Take-Off or its components shipped with this owner's manual may be manufactured under one or more of the following U.S. patents:

7,159,701 7,007,565 6,962,093 1,326,036 60,321,840.7

Other patents pending.

© Copyright 2015, Parker Hannifin Corporation, All Rights Reserved

General Information

Safety Information	1-3
Pump Support Recommendations	4
Support Bracket Locations	5
Foreword	6
Chelsea P.T.O. Safety Label Instructions	7-8
Function of Auxiliary Power Shafts	9
Spicer® Universal Joint Engineering Data	10

Installation Instructions CAT-D Series

Mounting P.T.O. on the Caterpillar Transmission	11-14
---	-------

Installation Instructions CAT-H Series

Mounting P.T.O. on the Caterpillar Transmission	15-17
---	-------

Installation Instructions 560V Series

Pre-Installation Overview	18
Port Locations	18
Mounting P.T.O. on the Transmission	19-21

Electrical & Hydraulic Installation..... 22**Vane Pump Information**

Start-Up Instructions	23-24
Pump Chart	25
Hydraulic Fluid Recommendations	26-28
Pump & Cartridge Breakdown Drawing	29
Changing Cartridge	30-35
Changing Porting - Suction Port	36-37
Vane Troubleshooting Guide	38-42

Power Take-Off Maintenance..... 43**Offer of Sale**..... 46-47

Safety Information

These instructions are for your safety and the safety of the end user. Read them carefully until you understand them.

General Safety Information

To prevent injury to yourself and/or damage to the equipment:

- Read carefully all owner's manuals, service manuals, and/or other instructions.
- Always follow proper procedures, and use proper tools and safety equipment.
- Be sure to receive proper training.
- Never work alone while under a vehicle or while repairing or maintaining equipment.
- Always use proper components in applications for which they are approved.
- Be sure to assemble components properly.
- Never use worn out or damaged components.
- Always block any raised or moving device that may injure a person working on or under a vehicle.
- Never operate the controls of the Power Take-Off or other driven equipment from any position that could result in getting caught in the moving machinery.

Proper Matching of P.T.O.



WARNING: A Power Take-Off must be properly matched to the vehicle transmission and to the auxiliary equipment being powered. An improperly matched Power Take-Off could cause severe damage to the vehicle transmission, the auxiliary driveshaft, and/or to the auxiliary equipment being powered. **Damaged components or equipment could malfunction causing serious personal injury to the vehicle operator or to others nearby.**

To avoid personal injury and/or equipment damage:

- Always refer to Chelsea catalogs, literature, and owner's manuals. Follow Chelsea recommendations when selecting, installing, repairing, or operating a Power Take-Off.
- Never attempt to use a Power Take-Off not specifically recommended by Chelsea for the vehicle transmission.
- Always match the Power Take-Off's specified output capabilities to the requirements of the equipment to be powered.
- Never use a Power Take-Off whose range of speed could exceed the maximum.



This symbol warns of possible personal injury.

Safety Information (continued)

Cold Weather Operation of Powershift P.T.O.



WARNING: During extreme cold weather operation [32°F (0°C) and lower], a disengaged Powershift Power Take-Off can momentarily transmit high torque that will cause unexpected output shaft rotation. This is caused by the high viscosity of the transmission oil when it is extremely cold. As slippage occurs between the Power Take-Off clutch plates, the oil will rapidly heat up and the viscous drag will quickly decrease.

The Power Take-Off output shaft rotation could cause unexpected movement of the driven equipment resulting in serious personal injury, death, or equipment damage.

To avoid personal injury or equipment damage:

- Driven equipment must have separate controls.
- The driven equipment must be left in the disengaged position when not in operation.
- Do not operate the driven equipment until the vehicle is allowed to warm up.

Rotating Auxiliary Driveshafts



WARNING:



- Rotating auxiliary driveshafts are dangerous. You can snag clothes, skin, hair, hands, etc. This can cause serious injury or death.
- Do not go under the vehicle when the engine is running.
- Do not work on or near an exposed shaft when the engine is running.
- Shut off the engine before working on the Power Take-Off or driven equipment.
- Exposed rotating driveshafts must be guarded.

Guarding Auxiliary Driveshafts



WARNING: We strongly recommend that a Power Take-Off and a directly mounted pump be used to eliminate the auxiliary driveshaft whenever possible. If an auxiliary driveshaft is used and remains exposed after installation, it is the responsibility of the vehicle designer and P.T.O. installer to install a guard.

 This symbol warns of possible personal injury.

Safety Information (continued)

Using Set Screws



WARNING: Auxiliary driveshafts may be installed with either recessed or protruding set screws. If you choose a square head set screw, you should be aware that it will protrude above the hub of the yoke and may be a point where clothes, skin, hair, hands, etc. could be snagged. A socket head set screw, which may not protrude above the hub of the yoke, does not permit the same amount of torquing as does a square head set screw. Also, a square head set screw, if used with a lock wire, will prevent loosening of the screw caused by vibration. Regardless of the choice made with respect to a set screw, an exposed rotating auxiliary driveshaft must be guarded.

Important: Safety Information and Owner's Manual

Chelsea Power Take-Offs are packaged with safety information decals, instructions, and an owner's manual. These items are located in the envelope with the P.T.O. mounting gaskets. Also, safety information and installation instructions are packaged with some individual parts and kits. **Be sure to read the owner's manual before installing or operating the P.T.O.** Always install the safety information decals according to the instructions provided. Place the owner's manual in the vehicle glove compartment.



WARNING: Operating the P.T.O. with the Vehicle in Motion

Some Power Take-Offs may be operated when the vehicle is in motion. To do so, the P.T.O. must have been properly selected to operate at highway speeds and correctly matched to the vehicle transmission and the requirements of the driven equipment.

If in doubt about the P.T.O. specifications and capabilities, avoid operating the P.T.O. when the vehicle is in motion. Improper application and/or operation can cause serious personal injury or premature failure of the vehicle, the driven equipment, and/or the P.T.O.

Always remember to disengage the P.T.O. when the driven equipment is not in operation.



This symbol warns of possible personal injury.

Caterpillar CX31/35 Series Transmissions Maximum Direct Mount Pump Limits CAT-D & CAT-H Series

Maximum Allowable Bending Moment is 80 N.m. (60 Lbs. ft.) Combined.

From the rear P.T.O. mounting face: maximum bending moment includes P.T.O., direct mount pump, and unsupported hydraulic lines. Support brackets designed to reduce the bending moment on the rear P.T.O. must insure that the 80 N.m. (60 Lbs. ft. or 720 Lbs. in.) limit cannot be exceeded. See drawing on [page 5](#) for bracket support locations.

Calculating bending moment:

$$\text{Lbs-in} = (\text{CGP} \times \text{PW}) + [(\text{LP} + \text{CGH}) \times \text{HPW}]$$

Most measurements will be in inches (in) so we will do the calculation in inches and convert to Pounds Feet (Lbs. ft.).

CAT-H Example

$$\begin{aligned} \text{Lbs-in} &= (3.74" \times 42.5 \text{ Lbs.}) + [(8.75" + 4") \times 22 \text{ Lbs.}] \\ &= 158.95 \quad + \quad 280.5 \\ &= 439.45 \text{ Lbs. in. divide by } 12" \\ &= 36.6 \text{ Lbs. ft. Total Bending Moment} \end{aligned}$$

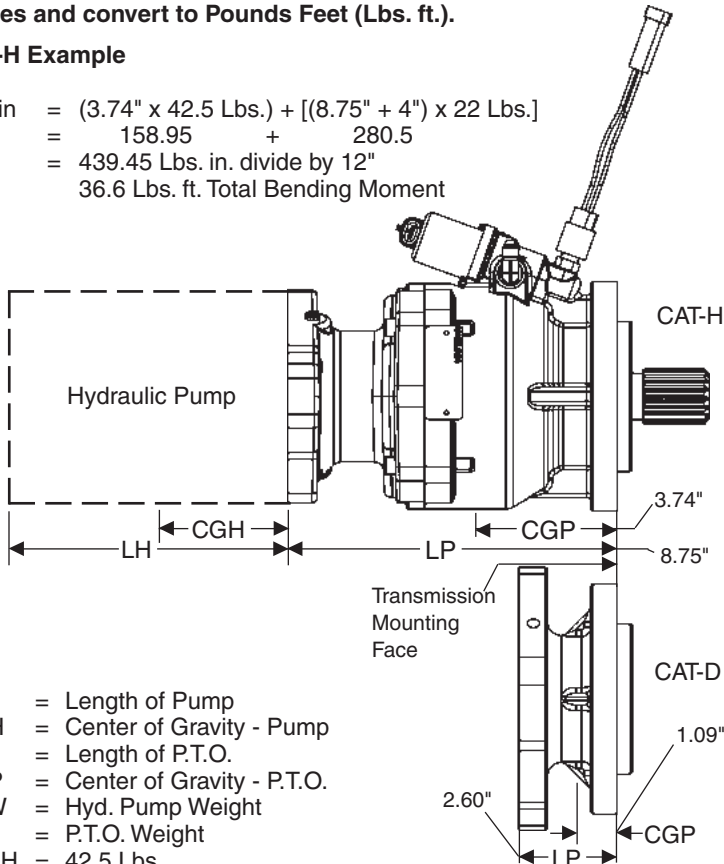

Key:

- LH = Length of Pump
- CGH = Center of Gravity - Pump
- LP = Length of P.T.O.
- CGP = Center of Gravity - P.T.O.
- HPW = Hyd. Pump Weight
- PW = P.T.O. Weight
- CAT-H = 42.5 Lbs.
- CAT-D = 8.2 Lbs.

NOTE: If pump center of gravity is not known divide LH by 2

Support Bracket Locations

If bolts are removed from the CX31 transmission to add mounting brackets, etc. they must be replaced with longer bolts so that thread engagement is maintained. The replacement bolts must be of the same grade and torqued to the required specifications. Thread engagement length and bolt torques are critical on the Aluminum Case and Cover of the CX Transmissions.

The bolts selected must have a thread Engagement length of twice the bolt diameter. Standard Torques on short bolts will strip the threads. The bolts must not be too long because the bolts will bottom out and damage the case.

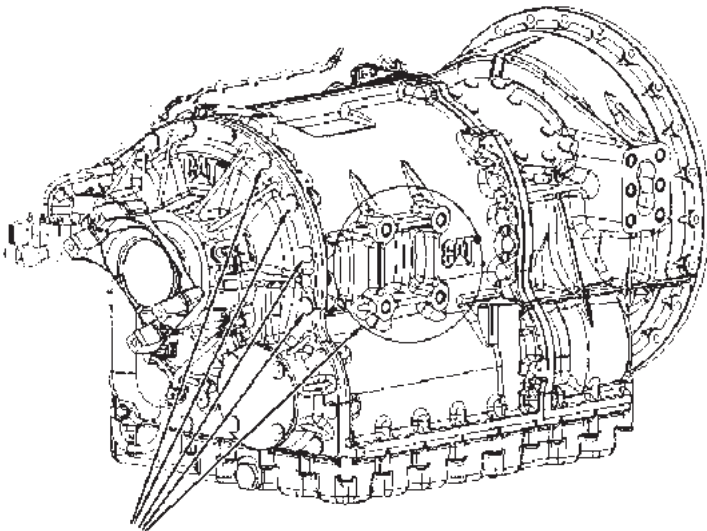

Bracket Attaching Locations

Foreword

Since our major objective is to show you how to get additional and more profitable miles from truck, tractor and trailer components, we want to provide you with information on the installation of Chelsea Power Take-Offs.

We all realize that an inadequate transmission will overwork any Power Take-Off in a very short period of time. In addition, a mismatched transmission / P.T.O. combination can result in unsatisfactory performance of the equipment right from the start.

Before you order new trucks, be sure you're getting the right transmission/ P.T.O. combination. It is of vital importance for efficient performance to have adequate power. To help you select the proper type, size and design of P.T.O. it is advisable to discuss your specific requirements with Chelsea P.T.O. specialists. They know their products and have easy access to manufacturers of equipment, transmissions and Power Take-Offs. They can inform you about everything you need to know about power, at the right time, before you specify components.

Exploded View of a Typical Powershift P.T.O.

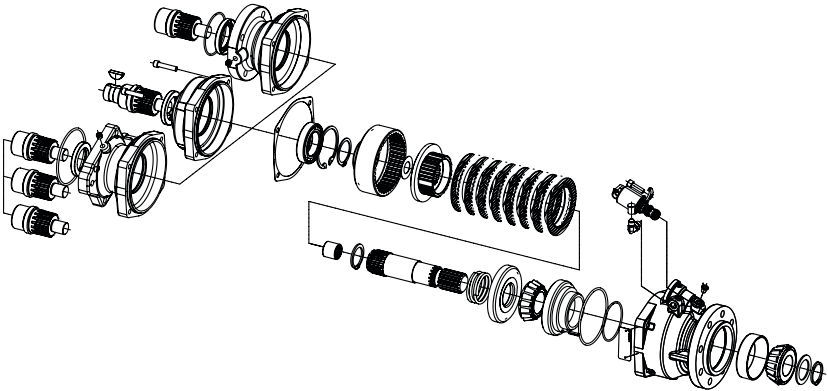

Chelsea P.T.O. Safety Label Instructions

1. The two black and orange on white 5" x 7" pressure sensitive vinyl labels, part number 379274; must be placed on the vehicle frame rails (one (1) on each side), in a position that would be **HIGHLY** visible to anyone that would go under the truck near the P.T.O. rotating shaft. If the vehicle is to be painted after these labels are installed, cover them with two (2) blank masking covers. Remove the masking covers after painting.
2. Place the one (1) black and orange on white 3.5" x 5" pressure sensitive vinyl label, part number 379275, on the visor nearest the operator of the vehicle, this must be placed near the P.T.O. visor label.
3. Place the one (1) red and white with black lettering 3.5" x 7.5" sensitive vinyl label, part number 379915, on the opposite side of the visor from the above label # 379275.
4. Place the one (1) white and black heavy duty card, part number 379276, in the vehicle glove box. Again in a position highly visible to the operator, for example: try to place this card on top of whatever may be in the glove box.

If you require labels, please order part number 328946X at no charge from your local Chelsea Warehouse or send request direct to:

**Parker Hannifin Corporation
Chelsea Products Division
8225 Hacks Cross Road
Olive Branch, MS 38654
Customer Service: (662) 895-1011**

Function of Auxiliary Power Shafts

An auxiliary power shaft transmits torque from the power source to the driven accessory. The shaft must be capable of transmitting the maximum torque and R.P.M. required of the accessory, plus any shock loads that develop.

An auxiliary power shaft operates through constantly relative angles between the power source and the driven accessory, therefore, the length of the auxiliary power shaft must be capable of changing while transmitting torque. This length change, commonly called "slip movement", is caused by movement of the power train due to torque reactions and chassis deflections.

Joint operating angles are very important in an auxiliary power joint application. In many cases, the longevity of a joint is dependent on the operating angles. (See chart below)

This information is limited to 1000 through 1310 series applications. For applications requiring a series larger than 1310, contact your local Chelsea distributor.

Determining Shaft Type

1. Solid or tubular?
 - a. In applications requiring more than 1000 R.P.M. or where the application necessitates a highly balanced auxiliary power shaft, a tubular shaft should be used.
 - b. Spicer's solid shafting auxiliary power joints are designed for 1000 or less R.P.M. intermittent service such as:
 - Driving small hydraulic pumps
 - Driving winches
 - Driving low speed product pumps
2. Joint Series should be determined using the chart on the following page.

Spicer® Universal Joint Operating Angles			
Prop. Shaft R.P.M.	Max. Normal Operating Angle	Prop. Shaft R.P.M.	Max. Normal Operating Angle
3000	5° 50'	1500	11° 30'
2500	7° 00'	1000	11° 30'
2000	8° 40'	500	11° 30'

Above based on angular acceleration of 100 RAD/SEC²

Spicer® Universal Joint Engineering Data

JOINT SERIES	1000	1100	1280	1310	
TORQUE RATING Automotive (Gas or Diesel Engine) Lbs. ft. Continuous	50	54	95	130	
TUBING Diameter Wall Thickness W = WELDED S = SEAMLESS	1.750 .065 W	1.250 .095 S	2.500 .083 W	3.00 .083 W	
FLANGE DIAMETER (Swing Diameter) Rectangular Type	3.500	3.500	3.875	3.875	
BOLT HOLES - Flange Yoke Circle Diameter Number Male Pilot Dia.	2.750 .312 4 2.250	2.750 .312 4 2.250	3.125 .375 4 2.375	3.125 .375 4 2.375	
DISTANCE ACROSS LUGS Snap Ring Construction	2.188	2.656	3.469	3.469	
BEARING DIAMETER	.938	.938	1.062	1.062	
MAXIMUM OPERATING SPEED * BY TUBE SIZE, SOLID SHAFT SIZE, AND LENGTH *(For speed below 500 R.P.M. or over 2500 R.P.M., contact your Chelsea Distributor)					
Tube Dia. & Wall Thickness Joint & Shaft (W=Welded S=Seamless)	MAX. INSTALLED LENGTH IN INCHES FOR GIVEN R.P.M. Centerline to Centerline of Joints For a Two Joint Assembly or Centerline of Joint to Centerline of Center Bearing for a Joint & Shaft R.P.M. - Revolutions per Minute				
	500	1000	1500	2000	2500
1.750" x .065" W	117"	82"	67"	58"	52"
1.250" x .095" S	91"	64"	52"	45"	40"
2.500" x .083" W	122"	87"	70"	62"	55"
3.000" x .083" W	-	-	-	85"	76"
SOLID SHAFT Diameter					
.750"	60"	42"	35"	30"	27"
.812"	62"	44"	36"	31"	28"
.875"	65"	46"	37"	32"	29"
1.000"	69"	49"	40"	35"	31"
1.250"	77"	55"	45"	39"	35"

NOTE: CAT transmission needs to be equipped with the optional rear P.T.O. drive arrangement.

Mounting the P.T.O. on the Transmission

When installing a P.T.O., always wear protective clothing and safety glasses.

WARNING: Oil may be hot. Use extreme caution to assure that you do not accidentally come in contact with hot oil.

1. Drain transmission oil before removing the rear aperture plate. After draining transmission fluid reinstall plug. **(Fig. 1)**
2. Remove the P.T.O. rear aperture plate with an 18 mm socket. **(Fig. 1)**
3. Remove the O-Ring and clean the aperture surface. **(Fig. 2)**

NOTE: Do not reuse the O-Ring that comes with the transmission cover plate.

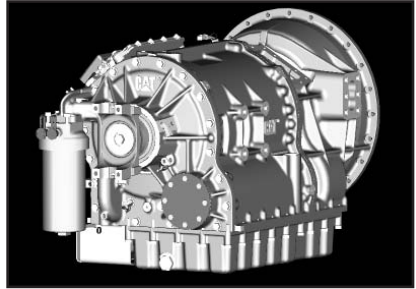

Fig. 1

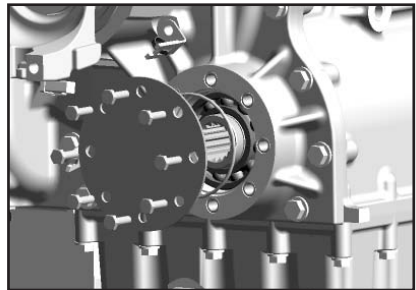

Fig. 2

“XV” Output

4. Mounting Constant Drive “XV” Output.
 - a. Install O-Ring, furnished with P.T.O., on transmission mounting surface **(Fig. 3)**. To prevent damage to O-Ring make sure it is installed in groove as shown.

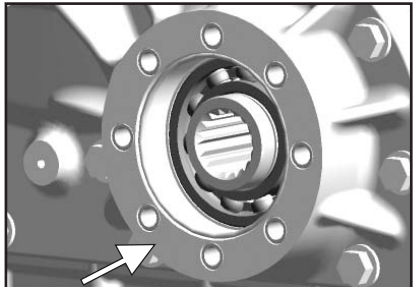

Fig. 3

Mounting the P.T.O. on the Transmission (continued)

- b. Install studs as shown in **Fig. 4**.

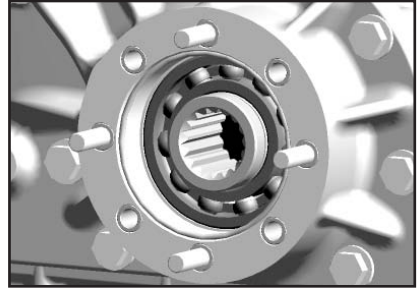

Fig. 4

- c. DO NOT bottom studs in holes. Install until shoulder is approximately one to two threads from the Transmission mounting surface. To verify correct installation measure from end of stud to transmission mounting surface. Correct length should be between 1.31 - 1.25 in. [33.2 - 31.8 mm].

- d. Mount P.T.O. as shown in **Fig. 5** and install flange nuts.

NOTE: Do not use sealing compounds because they are generally incompatible with Automatic transmission fluid.

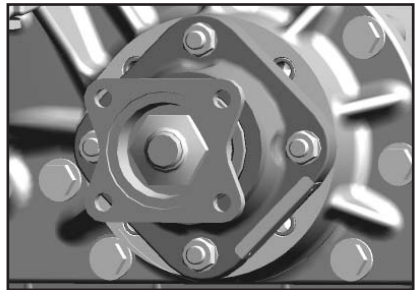

Fig. 5

- e. Tighten and torque in pattern shown in **Fig. 6**. Torque to 55 - 60 Lbs. ft. [75 - 81 N.m.]

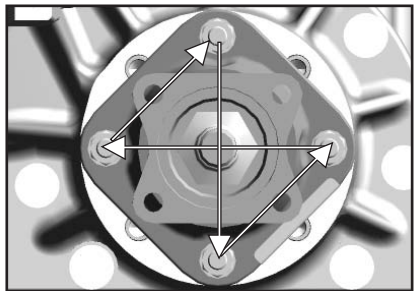

Fig. 6

Mounting the P.T.O. on the Transmission (continued)

CAUTION: Caterpillar transmissions have a different weight limit for rear mount P.T.O./Pump applications than Chelsea's recommended limits, see [page 4](#) of this manual or contact Caterpillar for weight limits on rear mount applications.

Direct Pump Drive Outputs

5. Mounting Constant Drive Pump Shafts
 - a. Install O-Ring as shown in **Fig. 7**.

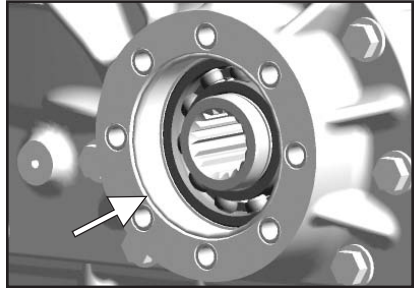

Fig. 7

- b. Install Studs as shown in **Fig. 8**
 - c. DO NOT bottom studs in holes. Install until shoulder is approximately one to two threads from the Transmission mounting surface. To verify correct installation measure from end of stud to transmission mounting surface. Correct length should be between 1.31 - 1.25 in. [33.2 - 31.8 mm].

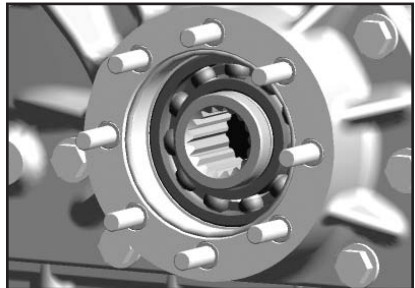

Fig. 8

- d. Install spring into pump shaft as shown in **Fig. 9**.

NOTE: Verify that snap ring has been installed on shaft.

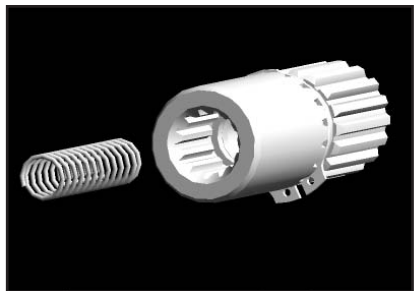

Fig. 9

Mounting the P.T.O. on the Transmission (continued)

- e. Install P.T.O. shaft into transmission counter shaft as shown in **Fig. 10**.



Fig. 10

NOTE: Verify that snap ring is installed on shaft before installing into transmission.

- f. Mount P.T.O. housing to transmission as shown in **Fig. 11**.
- g. Install flange nuts. Tighten and torque in a crossing pattern and Torque to 55 - 60 Lbs. ft. [75 - 81 N.m.].
- h. Refill transmission with fluid.

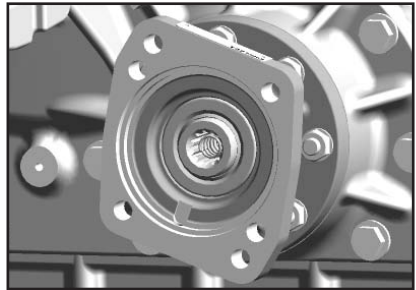

Fig. 11

6. Wet Spline Installation

- a. Wet spline installation will be the same as above (step through of the pump mount installation item 4 [page 12](#))
- b. The P.T.O. housing will not have an oil seal and there will be a "plug" (1/8" NPT) in the housing (**Fig. 12**).
- c. Install O-Ring that is supplied with kit in flange as shown (**Fig. 12**).
- d. Carefully mount pump so as not to damage O-Ring and torque as required.

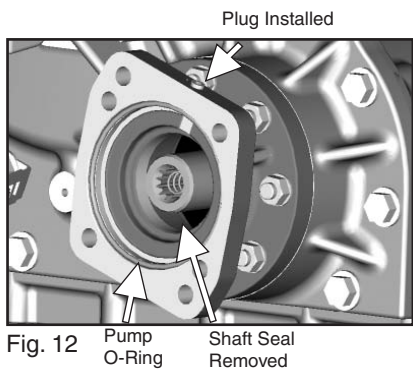

Fig. 12

CAUTION: Check Transmission Oil Level before running P.T.O. Assure that the transmission oil is at the proper level recommended by Caterpillar. Refer to Caterpillar for correct fluid types.

Mounting the P.T.O. on the Transmission

When installing a P.T.O., always wear protective clothing and safety glasses.

WARNING: Oil may be hot. Use extreme caution to assure that you do not accidentally come in contact with hot oil.

1. Drain transmission oil before removing the rear aperture. After draining transmission fluid reinstall plug.

2. Remove the P.T.O. rear aperture plate with an 18 mm socket. (Fig. 13)

3. Remove the O-Ring and clean the aperture surface. (Fig. 14)

NOTE: Do not reuse the O-Ring that comes with the transmission cover plate.

4. Install O-Ring, furnished with P.T.O., (Fig. 15). To prevent damage to O-Ring make sure it is installed in groove as shown.

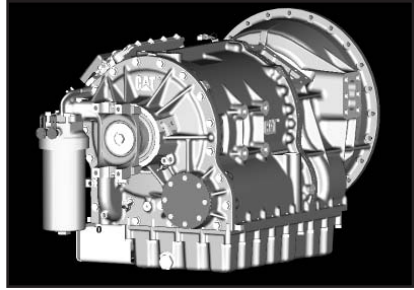

Fig. 13

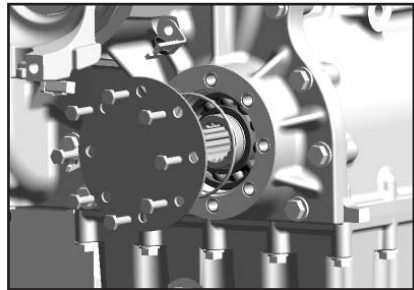

Fig. 14

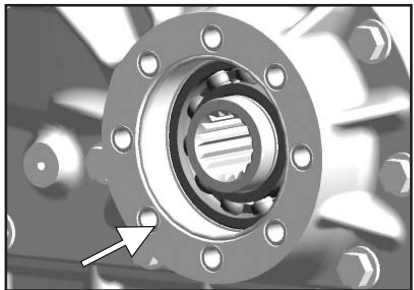

Fig. 15

Mounting the P.T.O. on the Transmission (continued)

5. Install Studs as shown in **Fig. 16**. DO NOT bottom studs in holes. Install until shoulder is approximately one to two threads from the transmission mounting surface. To verify correct installation measure from end of stud to transmission mounting surface. Correct length should be between 1.31 - 1.25 in. [33.2 - 31.8 mm].

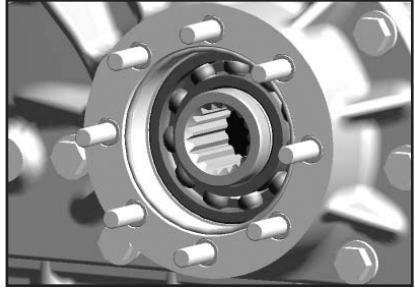

Fig. 16

NOTE: Prior to mounting the P.T.O. install pressure switch into P.T.O. Torque to 10 - 12 Lbs. ft. [13 - 16 N.m.].

6. Mount P.T.O. to transmission as shown using the flange nuts provided with Power Take-Off.

NOTE: Position of P.T.O. solenoid between 12 o'clock and 3 o'clock position when viewed from rear. (**Fig. 17**)



Fig. 17

Tighten and Torque flange nuts in a crossing pattern to 50 - 60 Lbs. ft. [75 - 81 N.m.]

7. Install the 90° elbow in the transmission pressure port as shown. Connect hose to the transmission pressure port as shown. Connect other end of hose to the P.T.O. 90° elbow located near the P.T.O. solenoid. (**Fig. 18**)

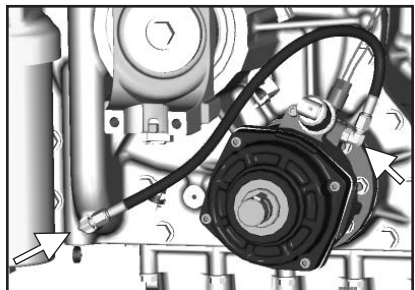

Fig. 18

Mounting the P.T.O. on the Transmission (continued)

8. Keep the bend radius of the hose as large as possible to avoid collapsing the hose and restriction of flow. Minimum bend radius is measured on the inside bend of the hose. To determine minimum bend, divide the total distance between ends (B length) by 2. For example, B = 6", minimum bend radius = 3" (**Fig. 19**).

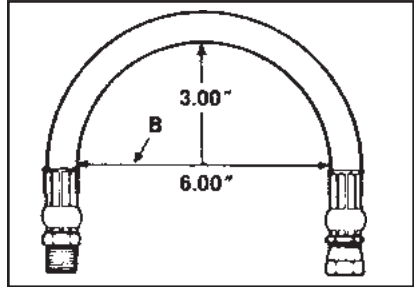

Fig. 19

9. Route hose and secure to stay out of the path (swing diameter) of the transmission output yoke (**Fig. 20**).

NOTE: It is not recommended to route the hose under the P.T.O. due to the possibility of the hose being exposed to road hazards.

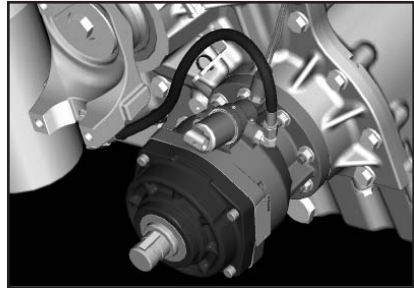

Fig. 20

10. See SK-424, [page 18](#) for complete wiring & P.T.O. plumbing installation information.

11. Refill transmission with fluid.

CAUTION: Check transmission oil level before running P.T.O. Assure that the transmission oil is at the proper level recommended by Caterpillar. Refer to Caterpillar for correct fluid types.

Pre-Installation Overview

Prior to installing P.T.O. determine pump port location for hose routing.

Pump Port Locations

The 560V Pump section comes with the pressure & suction port located opposite the P.T.O. Solenoid Valve ("1" position).

1. The pressure port can be indexed either opposite the solenoid or aligned with the solenoid.
2. The suction port can be indexed in 90° increments starting at the #1 position.

Starting at the #1 position when viewed from the rear of the P.T.O. and the pressure port opposite the solenoid, we can index the suction port at 1, 2, 3 & 4. With the pressure port aligned with the solenoid we can index the suction port at 5, 6, 7 & 8.

NOTE: Prior to mounting the P.T.O. install pressure switch into P.T.O. Torque to 10 - 12 Lbs. ft. [13 - 16 N.m.].

Port Locations

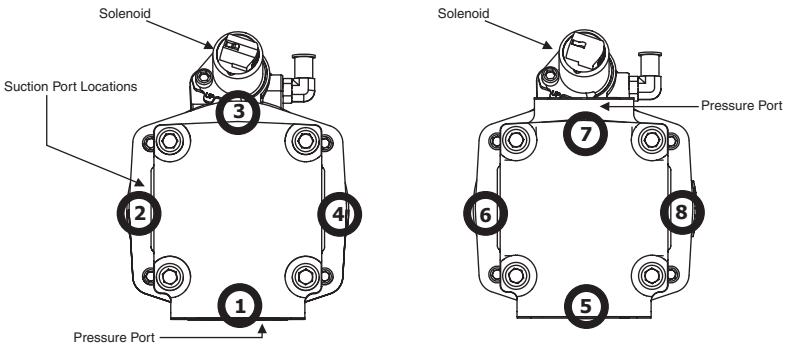

Mounting the P.T.O. on the Transmission

When installing a P.T.O., always wear protective clothing and safety glasses.

WARNING: Oil may be hot. Use extreme caution to Assure that you do not accidentally come in contact with hot oil.

1. Drain transmission oil before removing the rear aperture plate. After draining transmission fluid reinstall plug.
2. Remove the P.T.O. rear aperture plate with an 18 mm socket. (**Fig. 21**)
3. Remove the O-Ring and clean the aperture surface. (**Fig. 22**)

NOTE: Do not reuse the O-Ring that comes with the transmission cover plate.

4. Install O-Ring, furnished with P.T.O., (**Fig. 23**). To prevent damage to O-Ring make sure it is installed in groove as shown.
5. Install Studs as shown in **Fig. 24** DO NOT bottom studs in holes. Install until shoulder is approximately one to two threads from the transmission mounting surface. To verify correct installation measure from end of stud to transmission mounting surface. Correct length should be between 1.31 - 1.25 in. [33.2 - 31.8 mm].

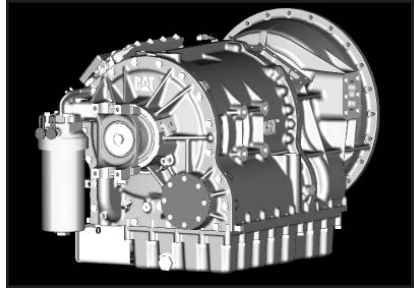

Fig. 21

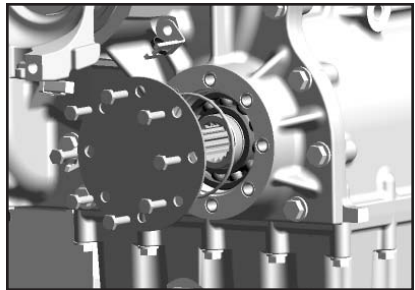

Fig. 22

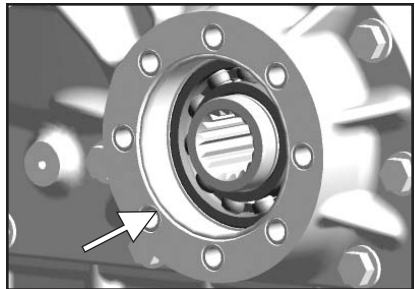

Fig. 23



Fig. 24

Mounting the P.T.O. on the Transmission (continued)

6. Mount P.T.O. to transmission as shown using the flange nuts provided with Power Take-Off.

NOTE: Position the P.T.O. solenoid between 12 o'clock and 3 o'clock position when viewed from rear. (Fig. 25)

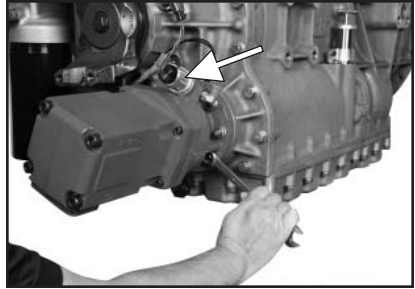

Fig. 25

7. DO NOT INSTALL P.T.O. with the solenoid between the 8 o'clock to 11 o'clock position as it could come into contact with the output yoke/ flange on the transmission. (Fig. 26)

Tighten and torque flange nuts in a crossing pattern to 50 - 60 Lbs. ft. [75 - 81 N.m.]

8. Install the 90° elbow in the transmission pressure port as shown. Connect hose to the transmission port as shown. Connect other end of hose to the P.T.O. 90° elbow located near the P.T.O. solenoid. (Fig. 27)

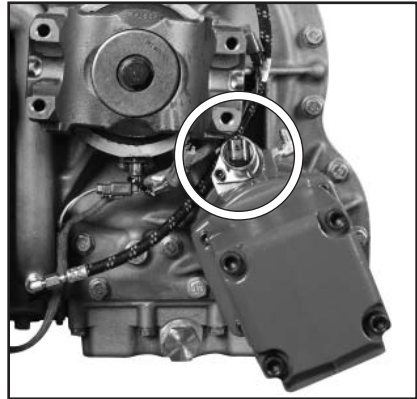

Fig. 26

NOTE: Route hose and secure to stay out of the path (swing diameter) of the transmission output yoke. It is not recommended to route the hose under the P.T.O. due to the possibility of the hose being exposed to road hazards.

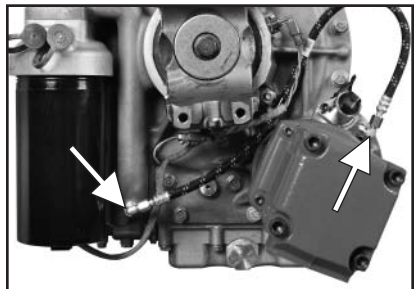

Fig. 27

Mounting the P.T.O. on the Transmission (continued)

9. Keep the bend radius of the hose as large as possible to avoid collapsing the hose and restriction of flow. Minimum bend radius is measured on the inside bend of the hose. To determine minimum bend, divide the total distance between ends (B length) by 2. For example, B = 6", minimum bend radius = 3". **(Fig. 28)**

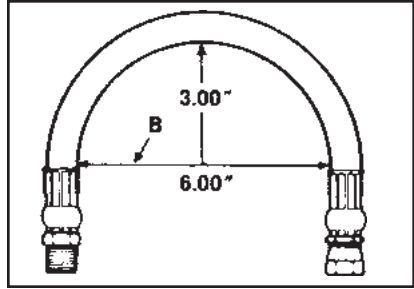

Fig. 28

10. See SK-424, [page 22](#) for complete wiring & P.T.O. plumbing installation information.
11. Refill transmission with fluid.

CAUTION: Check transmission oil level before running P.T.O. Assure that the transmission oil is at the proper level recommended by Caterpillar. Refer to Caterpillar for correct fluid types.

12. Connect hydraulic hoses to pump and complete installation of truck hydraulic circuit.

NOTE: It is not recommended to run the P.T.O. / pump before the truck hydraulic circuit is complete.

See [page 23](#) for complete pump start up information

**12V Electrical & Hydraulic Installation CAT-H & 560V
 (SK-424 Rev B)**

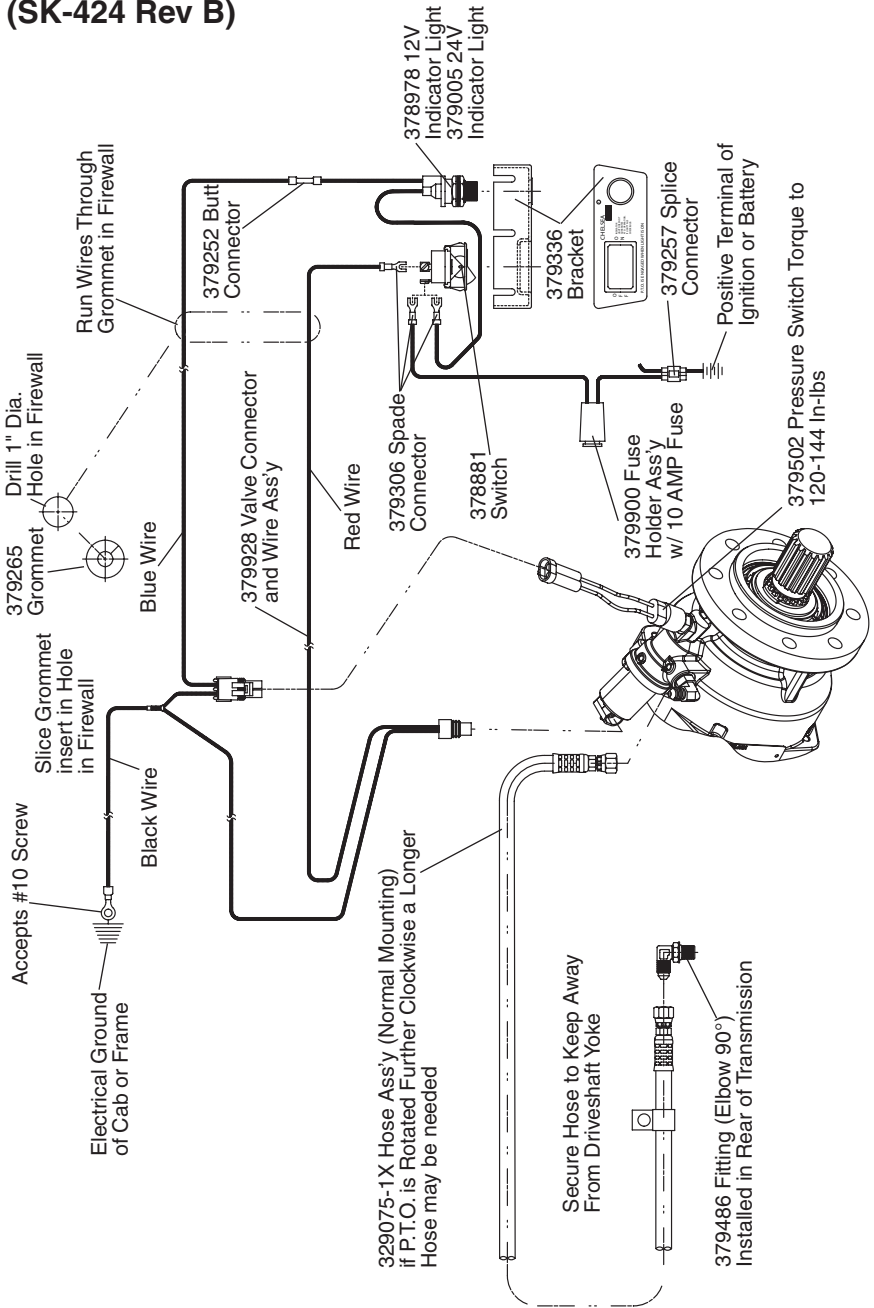

Start-Up Instructions

General

All DENISON Hydraulics vane pumps & motors are individually tested to provide the best quality & reliability. Modifications, conversions & repairs can only be done by authorized dealers or OEM to avoid invalidation of the guarantee.

The pumps & motors are to be used in the design limits indicated in all the sales bulletins.

Do not modify or work on the pump under pressure or when the engine is on. Qualified personnel are required to assemble and set-up hydraulic devices.

Always conform to regulations (safety, electrical, environment).

The following instructions are important to follow to obtain good service life from the unit.

Rotation & Ports Indication

- The rotation and ports orientation are viewed from the shaft end.
- CW stands for clockwise, right-hand rotation.
- CCW stands for counter-clockwise, left-hand rotation.

Start-Up Check-Up

Check that the assembly of the power unit is correct:

The distance between the suction pipe & the return lines in the tank should be as great as possible.

A bevel on both suction & return lines is recommended to increase the surface and so lower the velocity. We suggest a 45° minimum angle.

Velocities : inlet $0.5 < x < 19$ m/s ($164 < x < 6.23$ ft per sec.)

: return $x < 6$ m/s ($x < 19.7$ ft per sec.)

: Always insure that all return and suction lines are under the oil level to avoid forming aeration or vortex effect. This should be done under the most critical situation (all cylinders extended for example). Straight and short pipes are the best.

Start-Up Instructions (continued)

$$V = \frac{Q \text{ (Lpm)}}{6 \times \pi \times r^2 \text{ (cm)}} = \text{m/s}$$

$$V = \frac{Q \text{ (GPM)}}{3.12 \times \pi \times r^2 \text{ (in)}} = \text{ft/s}$$

The size of the air filter should be 3 times greater than the max. instant return flow (all cylinders in movement for example).

DENISON does not recommend inlet strainers. If needed, a 100 mesh (149 microns) is the finest mesh recommended.

Make sure that all protective plugs & covers have been removed.

Start-up:

- The tank has been filled up with a clean fluid in proper conditions.
- Flushing the system with an external pump prior to the start-up is good.
- To allow a good priming of the pump, the air should be bled off.
- The first valve on the circuit should be open to tank.
- Air bleed off valves are available on the market place.
- It is possible to bleed off the air by creating a leak in the P port of the pump.



WARNING: This has to be done in low pressure mode as it could create a dangerous fluid leak. Make sure that the pressure cannot rise (open center valve to tank, pressure relief valve unloaded).

- When oil free of air appears, tighten the connectors to the correct torque.
- The pump should prime within a few seconds. If not, please read the troubleshooting guide ([page 38](#)).
- If the pump is noisy, please troubleshoot the system.
- Never operate the pump at top speed and pressure without checking the completion of pump priming.

Minimum Inlet Pressure



This symbol warns of possible personal injury.

Model Code	Part Number	Vendor Description	Displacement in ³ /rev [ml/rev]	Flow (1) GPM [l/m]	Max Pressure PSI [Bar] (2)		Speed RPM (3)	
					Intermittent	Continuous	Minimum	Maximum
03	380418-03	CARTR T6CM UNIT CCW S1	0.66 [10.8]	3.42 [12.9]	4000 [275]	3500 [240]	400	2800
05	380418-05	CARTR T6CM UNIT CCW S1	1.05 [17.2]	5.45 [20.6]	4000 [275]	3500 [240]	400	2800
06	380418-06	CARTR T6CM UNIT CCW S1	1.30 [21.3]	6.76 [25.6]	4000 [275]	3500 [240]	400	2800
08	380418-08	CARTR T6CM UNIT CCW S1	1.61 [26.4]	8.36 [31.7]	4000 [275]	3500 [240]	400	2800
10	380418-10	CARTR T6CM UNIT CCW S1	2.08 [34.1]	10.81 [41.0]	4000 [275]	3500 [240]	400	2800
12	380418-12	CARTR T6CM UNIT CCW S1	2.26 [37.1]	11.76 [44.4]	4000 [275]	3500 [240]	400	2800
14	380418-14	CARTR T6CM UNIT CCW S1	2.81 [46.0]	14.58 [55.3]	4000 [275]	3500 [240]	400	2800
17	*380418-17	CARTR T6CM UNIT CCW S1	3.56 [58.3]	18.48 [70.0]	4000 [275]	3500 [240]	400	2800
20	380418-20	CARTR T6CM UNIT CCW S1	3.89 [63.8]	20.23 [76.5]	4000 [275]	3500 [240]	400	2800
22	*380418-22	CARTR T6CM UNIT CCW S1	4.29 [70.3]	22.28 [84.4]	4000 [275]	3500 [240]	400	2800
25	*380418-25	CARTR T6CM UNIT CCW S1	4.84 [79.3]	25.14 [95.2]	4000 [275]	3500 [240]	400	2500
28	380418-28	CARTR T6CM UNIT CCW S1	5.42 [88.8]	27.90 [106.6]	3000 [210]	2300 [160]	400	2500
31	*380418-31	CARTR T6CM UNIT CCW S1	6.10 [100.0]	31.70 [119.9]	3000 [210]	2300 [160]	400	2500

*Released

(1) Flow at 1200 rpm pump speed, 960 R.P.M. engine and 0 PSI

(2) Pressures are stated for antiwear petroleum base only

(3) Based on antiwear petroleum or non antiwear petroleum base.

For synthetic fluids, water in oil emulsions or water glycols MAX RPM is 1800.

Contact Chelsea for availability of other cartridge sizes.

Hydraulic Fluid Recommendations:

Please read the charts in the sales leaflets as the minimum requested inlet pressure varies versus the displacement and the speed. Never go under 0.8 bar Absolute (-0.2 bar relative) 11.6 PSI Absolute (-2.9 PSI G).

Maximum Inlet Pressure

It is recommended to always have at least 1.5 bar (22 PSI) differential between inlet and outlet. Standard shaft seals are limited to 0.7 bar (10 PSI G) but some allow 7 bar (100 PSI G).

Minimum Outlet Pressure

It is recommended to always have at least 1.5 bar (22 PSI) differential between inlet and outlet.

Fluids:

DENISON Classifications

Types of fluids: For all types of fluids, DENISON's products have different pressures, speeds & temperature limits. Please refer to the sales leaflets.

HF-0 = Anti-wear petroleum base.

HF-1 = Non anti-wear petroleum base.

HF-2 = Anti-wear petroleum base.

HF-3 = Water-in-oil invert emulsions.

HF-4 = Water glycol solutions.

HF-5 = Synthetic fluids.

Filtration Recommendations

NAS 1638 class 8 or better.

ISO 18 / 14 or better.

Inlet strainers: DENISON does not recommend inlet strainers. If requested, a 100 mesh (149 microns) is the finest mesh recommended.

Recommended Fluids

Petroleum based antiwear R & O fluids. These fluids are the recommended fluids for pumps & motors. Maximum catalog ratings and performance data are based on operation with these fluids. These fluids are covered by DENISON Hydraulics HF-0 and HF-2 specifications.

Acceptable Alternate Fluids

The use of fluids other than petroleum based antiwear R & O fluids requires that the maximum ratings of the pumps will be reduced. In some cases the minimum replenishment pressures must be increased.

Viscosity

	Mobile	Industrial
Max. (cold start, low speed & pressure)	2000 cSt - 9400 SUS	860 cSt - 3900 SUS
Max. (full speed & pressure)	108 cSt - 500 SUS	108 cSt - 500 SUS
Optimum (max. life)	30 cSt - 140 SUS	30 cSt - 140 SUS
Min. (full speed & pressure for HF-1, HF-3, HF-4 & HF-5 fluids)	18 cSt - 90 SUS	18 cSt - 90 SUS
Min. (full speed & pressure for HF-0 & HF-2 fluids)	10 cSt - 60 SUS	10 cSt - 60 SUS

Viscosity Index

90 min. Higher values extend the range of operating temperatures.

Temperatures

The usual limiting factor of temperature (low or high) comes from the obtained viscosity. The seals are sometimes the limit: standard seals range from -30° C to 90° C (-9.4° F to 194° F).

Maximum fluid temperature (Ø)	° C	° F
HF-0, HF-1, HF-2	+100	+ 212
HF-3, HF-4	+50	+ 122
HF-5	+70	+ 158
Biodegradable fluids (esters & rapeseed base)	+65	+ 149
Minimum fluid temperature (Ø) (also depend on max. viscosity)	° C	° F
HF-0, HF-1, HF-2, HF-5	-18	-0.4
HF-3, HF-4	+10	+50
Biodegradable fluids (esters & rapeseed base)	-18	-0.4
Over or under these values, please contact DENISON.		

Water Contamination In The Fluid

Maximum acceptable content of water:

- 0.10 % for mineral base fluids.
- 0.05 % for synthetic fluids, crankcase oils, biodegradable fluids.

If the amount of water is higher, then it should be drained off the circuit.

Pump & Cartridge Breakdown Drawing

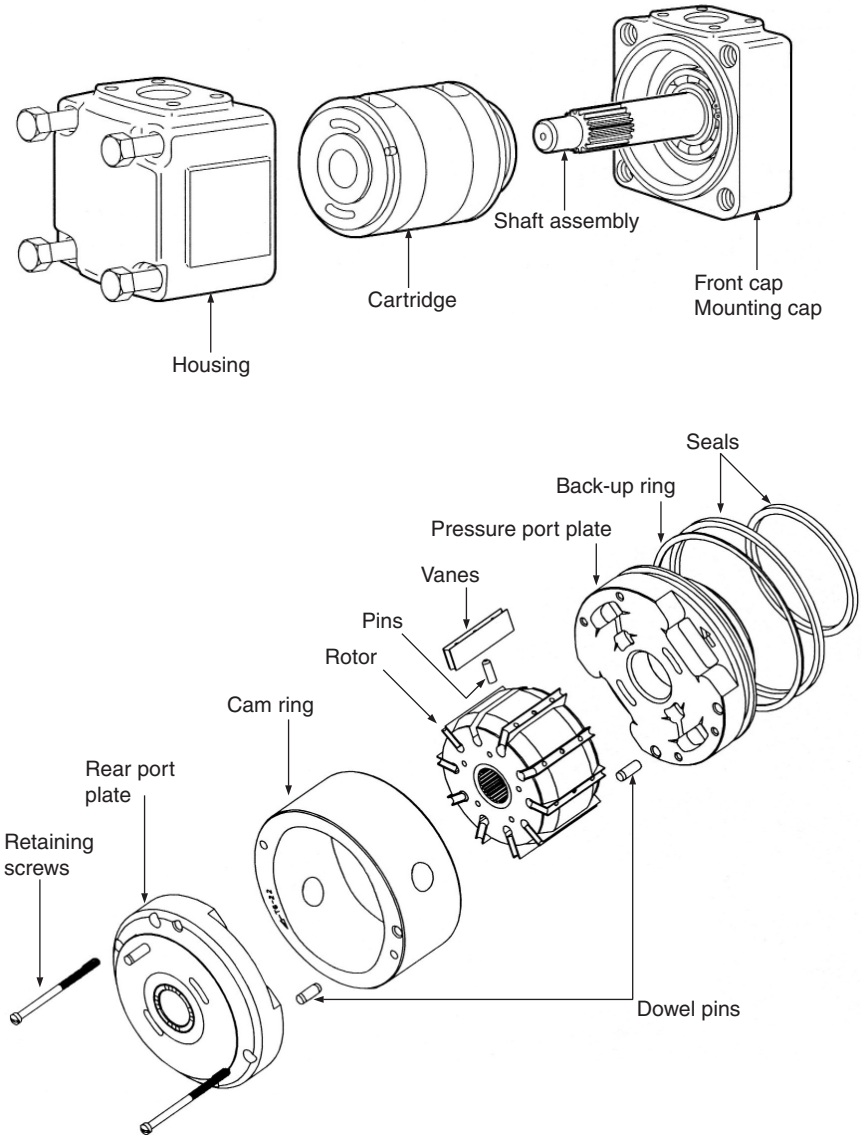

! WARNING: The purpose of the two screws is just to hold the cartridge together. When tightening them, check the rotation of the rotor & vane assembly.

Changing Cartridge

Removal

1. Install the PTO/Pump on the table. (A hole in the table or a bracket will help to unscrew the 4 pump bolts.) **(Fig. 29)**

NOTE: P.T.O. must be supported on table



Fig. 29

2. Unscrew the 4-Bolts **(Fig. 30)**.

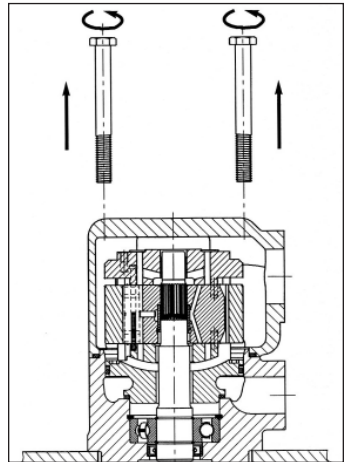

Fig. 30

Changing Cartridge (continued)

3. Remove the housing (Fig. 31).



WARNING: This seal can sometimes stay in the housing.

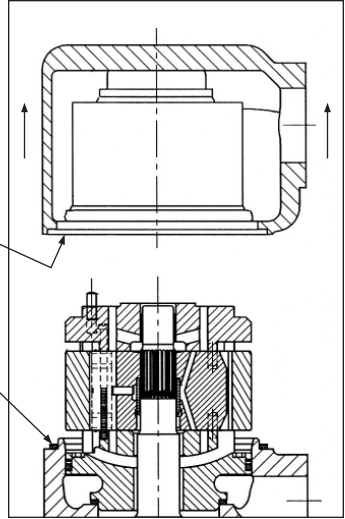

Fig. 31

4. Disassemble the cartridge / front cap with an extractor (Fig. 32).

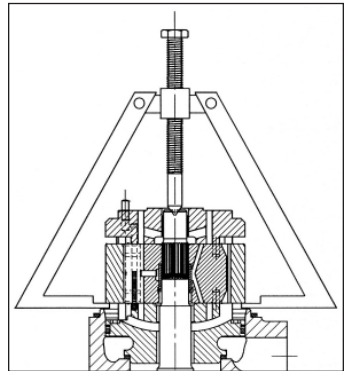

Fig. 32

 This symbol warns of possible personal injury.

Changing Cartridge (continued)

 **WARNING:** If you want to reassemble a new cartridge, go to [page 11](#) (Fig. 33).

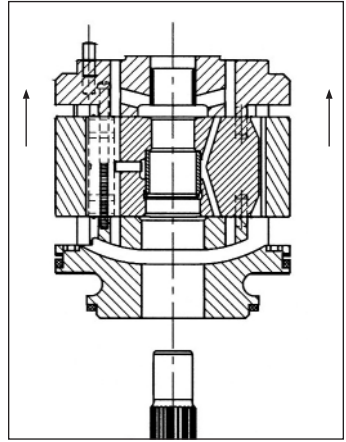

Fig. 33

5. Remove cartridge from shaft (Fig. 34).

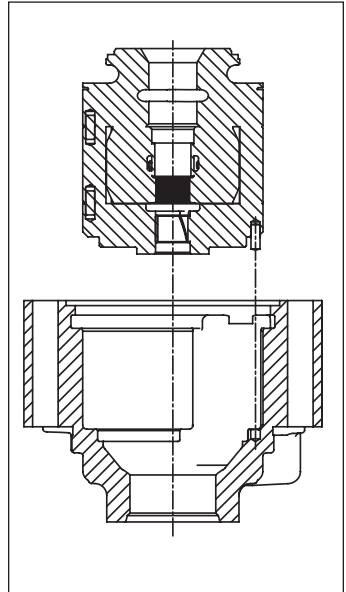

Figure 34

 This symbol warns of possible personal injury.

Changing Cartridge (continued)

Installation

6. Fit the cartridge into the housing (Fig. 35).

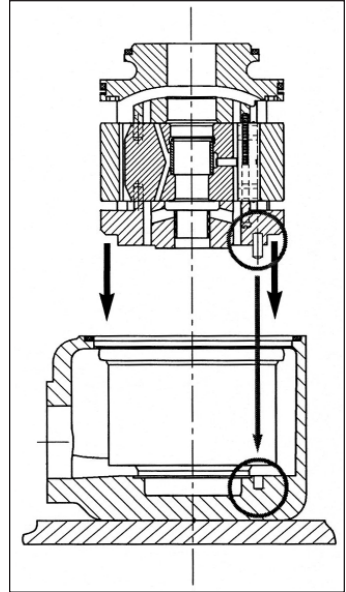

Fig. 35

7. Check if the dowel pin is in its position in the housing by trying to rotate the cartridge (Fig. 36).

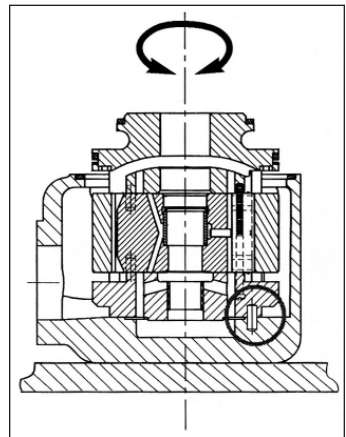



Fig. 36

 This symbol warns of possible personal injury.

Changing Cartridge (continued)

 **WARNING:** Put some grease on the seals to prevent them from moving. If the cartridge does rotate, the dowel pin is not in the hole. Take the cartridge out and try again.

 **WARNING:** Never use a hammer. The cartridge is to fit into the housing without any tools. (Fig. 37)

8. Assemble the front cap ass'y on the housing & cartridge ass'y (Fig. 38).

 **WARNING:** Position the shaft / front cap ass'y only if the cartridge is well positioned, dowel pin in the housing dowel pin hole. Put some grease on the seals to prevent them from moving.

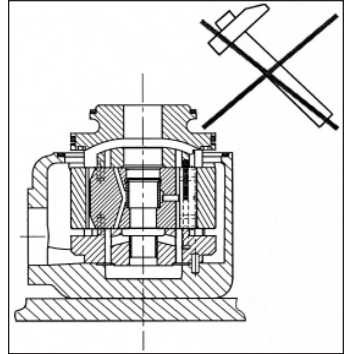

Fig. 37

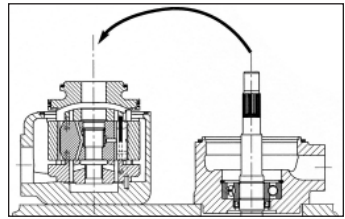

Fig. 38

 This symbol warns of possible personal injury.

Changing Cartridge (continued)

9. Final ass'y (**Fig. 39**).
 - a. Always check if the shaft rotates freely. If not, disassemble and go back to the previous step.
 - b. Flip / rotate the pump to fit the 4 screws.
 - c. Fix the pump to the table (see [page 30](#)) before tightening the pump's bolts.
 - d. Check the porting configuration (see [table page 36](#)).
 - e. Tighten the 4-Bolts. Step by step to avoid damaging the seals (**Fig. 40**).
 - f. Always check if the shaft rotates freely. If not, disassemble and go back to the previous step.

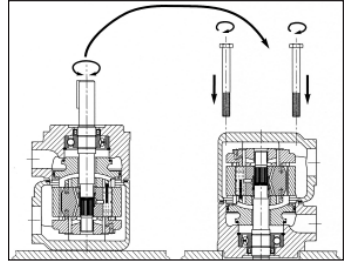

Fig. 39

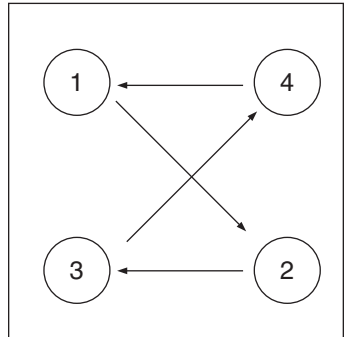

Fig. 40

Torque Requirements.

108-115 N.m.	80-85 Lbs. ft.
--------------	----------------

Changing Porting - Suction Port

1. Install the pump on the table. (A hole in the table or a bracket will help to unscrew the 4 pump bolts.) **(Fig. 41)**
2. Unscrew the four 3/8" Hex Socket capscrews (.500" - 13" x 4.00").
3. Keep two bolts.

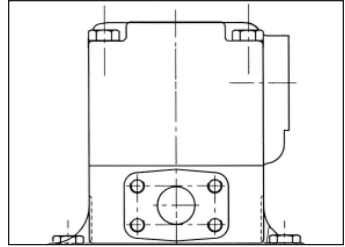

Fig. 41

4. Rotate the housing with a bar blocked between the two screws **(Fig. 42)**.

NOTE: The cartridge will rotate with the housing.



WARNING: Do not lift the housing, this to prevent the dowel pin from leaving its position in the housing.

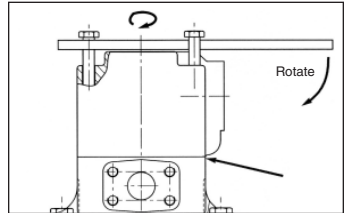

Fig. 42

5. Put the 3/8" capscrews (.500" - 13" x 4.00") back **(Fig. 43)**.

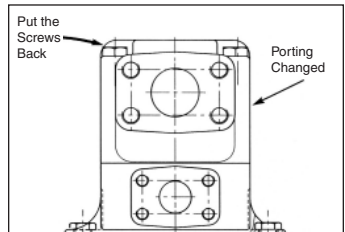

Fig. 43

Changing Porting - Suction Port (continued)

6. Tighten to the correct torque (see table hereunder).
 - a. Always check if the shaft rotates freely. If not, disassemble and go back to the previous step.
 - b. Check the porting configuration (see [page 36](#)).
 - c. Tighten the four 3/8" Hex Socket capscrews (.500" - 13" x 4.00"). Step by step to avoid damaging the seals (**Fig. 44**).
 - d. Always check if the shaft rotates freely. If not, disassemble and go back to the previous step.

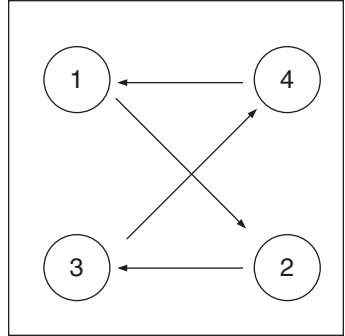

Fig. 44

Torque Requirements.

108-115 N.m.	80-85 Lbs. ft.
--------------	----------------

NOTE: When removing the four 1/4" socket capscrews from the pressure port section of the P.T.O. housing. Reinstall the 4 capscrews and torque to the following - 30-35 N.m. [22-26 Lbs.ft]

Vane Troubleshooting Guide

1. No flow, no pressure
 - a. Is the pump rotating?
 - a-1. Check if the coupling is rotating. If not, check the rotation of the electric motor.
 - a-2. Check the keys of the pump and E motor shaft.
 - a-3. Check if the shaft is not broken.
 - b. Is the rotation in the correct direction?
 - b-1. Check if the rotation of the pump corresponds to the arrow on the name plate.
 - b-2. Check if the wiring of the electric motor is correct.
 - c. Is the air bleed-off done?
 - c-1. Check that no air is still located in the pressure line. Loosen a connector.
 - d. How are the inlet conditions?
 - d-1. Check if the inlet gate valve is not closed.
 - d-2. Check the oil level.
 - d-3. Check if the inlet hose in the tank is under the oil tank level.
 - d-4. Check if an air intake is not disturbing the inlet (missing inlet flange seal, air trapped in suction line as examples).
 - d-5. Check if the pump is not located too high above the oil level.
 - d-6. Check if the tank is not completely sealed. Then the lack of atmospheric pressure will not allow the pump to prime.
 - d-7. Check if all connections and seals are air-tight.
 - e. Is the Viscosity not too high?
 - e-1. Check if the oil characteristics are not incompatible with the temperature and the pumps requirements. Too high Viscosity will “stick” the vein fluid and enable the pump to suck the oil correctly.
 - f. Is the pump flow not going somewhere else?
 - f-1. Check the hydraulic circuit and the main sequences. Doing so, you will check if all the valves are set or work properly.
 - f-2. Check if the main relief valve is not set at an extremely low pressure and therefore bringing all the flow back to the tank.
 - f-3. Check if in the directional valves the spools are not sticking in a position that brings the flow back to the tank.
 - f-4. Check if the check valve is not mounted “upside down”.

Vane Troubleshooting Guide (continued)

g. Is the receptor working correctly?

- g-1. Check if the motor does not let all the flow leak internally.
- g-2. Check if the cylinder inner seals are not ruined.

h. Is the speed high enough?

- h-1. Check if the minimum speed is reached. Mobile pumps require 400 rpm and industrial pumps require 600 rpm.

2. Not enough flow (or not the flow required)

a. Are the components OK?

- a-1. Check the displacement of the pump.
- a-2. Check if the speed of the pump is not too low or too high (E motor or thermic engine sized too small so dropping the speed too low).
- a-3. Check if the main relief valve is not set at an extremely low pressure and therefore venting some flow back to the tank.
- a-4. Check if in the directional valves the spools are not sticking in a position that brings part of the flow back to the tank.
- a-5. Check if the hydraulic motor is not leaking internally due to a bad efficiency, low viscosity.
- a-6. Check if the cylinder inner seals are not ruined and therefore allow internal leakage.

b. Is the connection from the tank to the pump correct?

- b-1. Check if there is no air intake between the pump and the inlet pipe (bad seals for example).
- b-2. Check if the inlet hose is convenient for the required velocity ($0,5 < V < 1,9$ m/s).
- b-3. Check if the pump is not too high compared to the oil level or if the pump is not too far from the tank (check the inlet absolute pressure with the catalog values).
- b-4. Check if the gate valve is not semi-open.
- b-5. Check if the inlet strainer is sized correctly (250 m mesh mini.) or not clogged.

c. Is the tank design correct?

- c-1. Check if the oil level is correct.
- c-2. Check if the suction pipe is under the oil level during the complete cycle of the machine.
- c-3. Check if the inlet hose fitted in the tank is cut with an angle wider than 45° .
- c-4. Check if this inlet hose is not too close to the tank wall or to the bottom of the tank and therefore limits the "vein flow".

Vane Troubleshooting Guide (continued)

- c-5. Check if the suction hose is not located near the return line and therefore sucking a lot of air coming from these turbulences.
 - c-6. Check if baffles are required to allow correct aeration of the fluid.
 - c-7. Check if the air filter is not clogged or undersized (not well dimensioned).
 - c-8. Check if the tank is not fully tight, not allowing the atmospheric pressure to apply.
- d. Is the oil convenient?
- d-1. Check if the oil characteristics are not incompatible with the pumps requirements.
 - d-2. Check if the viscosity is not too high, therefore "sticking" some vanes in the rotor or blocking the vein fluid.
 - d-3. Check if the high temperature does not destroy the viscosity of the fluid. Doing so, the internal leakage will "consume" the flow.
3. No pressure
- a. Is the hydraulic circuit correctly designed?
 - a-1. Check the hydraulic circuit schematic.
 - b. Is the circuit correctly piped?
 - b-1. Compare the schematic to the piped circuit.
 - c. Are the components working properly?
 - c-1. Check the main sequences. Doing so, you will check if all the valves are set or work properly.
 - c-2. Check if the main relief valve is not set at an extremely low pressure and therefore bringing all the flow back to the tank.
 - c-3. Check if in the directional valves the spools are not sticking in a position that brings the flow back to the tank.
4. Not enough pressure
- a. Check as when "no pressure" 3.
 - b. Is the system well dimensioned?
 - b-1. Check if the flow required is not over the available flow and therefore cannot build-up pressure.
 - c. Is there an internal leakage somewhere that maintains a certain pressure?
 - c-1. Check all the possible faulty components, from the pump to all the receptors and intermediates (high pressure seals, mechanical wear).

Vane Troubleshooting Guide (continued)

5. Uncommon noise level

a. Is the noise coming from the pump?

- a-1. Check the mechanical link of the pump shaft: alignment, balancing of the coupling or Universal joint, key properly fastened.
- a-2. Check if the air bleed has been done correctly.
- a-3. Check if there is no air intake from the tank to the pump (nor through the shaft seal).
- a-4. Check if the hose strain force does not create this noise.
- a-5. Check if the oil level is correct.
- a-6. Check if the oil in the tank is not aerated.
- a-7. Check if the strainer is not clogged or under-dimensioned.
- a-8. Check if the inlet pipe is under the oil level.
- a-9. Check if the air filter is not clogged or too small.
- a-10. Check if the speed is not incompatible with the catalog values.
- a-11. Check if the oil is compatible with the catalog recommendations.
- a-12. Check if the inlet pressure is not higher than the outlet pressure.

b. Is the noise coming from the surroundings?

- b-1. Check the hoses and see if the noise is not coming back to the pump this way.
- b-2. Check the pressure piping and see if its length dumps or amplifies the noise.
- b-3. Check if the structure of the tank is stiff enough to avoid amplification / resonance.
- b-4. Check the E motor fan.
- b-5. Check the balancing of the E motor.
- b-6. Check the water cooler and its theoretical limits.
- b-7. Check the filtration unit, its capacity and if the noise does not come from the opened by-pass valve.

6. Unusual heat level

a. Does the heat appear when the pump is running without pressure?

- a-1. Check the oil level and the suction pipe. Is the oil coming to the pump (check the length of the pipe, its internal diameter, all that could influence the inlet pressure)?
- a-2. Check if the air bleed has been done correctly.
- a-3. Check if the flow versus the volume of oil in the tank is correct to obtain a good cooling effect.
- a-4. Check if a cooler is required or, if there is one, if it is well dimensioned.
- a-5. If there is a cooler, check if it is working (example for water cooler: is the water flow open or sufficient).
- a-6. Check if the hydraulic circuit is not bringing back the flow directly to the inlet port. Doing so, it would create a very small closed circuit not able to cool down the fluid.

Vane Troubleshooting Guide (continued)

- a-7. Check the quality of the fluid.
 - a-8. Check the velocity of the fluid.
 - a-9. Check the filtration unit, its capacity and if the heat does not come from the open by-pass valve or if it is under-dimensioned (bigger delta P).
- b. Does the heat appear when the pump is running with pressure?
- b-1. Check the viscosity.
 - b-2. Check the pressure rating.
 - b-3. Check if the cooler is working correctly or well dimensioned.
 - b-4. Check if the relief valve is not creating this heat because always open.
 - b-5. Check if any other component in the system is not creating this heat due to an internal defect.
 - b-6. Check if there is a big temperature differential between the inlet and the outlet.
7. Shaft seal leakage
- a. Is the seal destroyed?
 - a-1. Check the alignment and the correct power transmission (non homokinetic movement, high radial force as examples).
 - a-2. Check the inlet pressure and compare it to the catalog values.
 - a-3. Check if the bad suction conditions do not create a vacuum that could even reverse the seal lip.
 - a-4. Check if the external environment is not too dirty and therefore ruining the seal.
 - b. Is the seal only leaking?
 - b-1. Check the alignment of the front shaft and check if there is not any radial load.
 - b-2. Check if seal lip has not been cut during a maintenance operation.
 - b-3. Check if the inlet pressure is not over or under the catalog values. This has to be done for the whole cycle because the inlet pressure can vary from time to time.
 - b-4. Check if the seal material has not been modified because of a too warm environment. The seal can vulcanize and stop sealing correctly.
 - b-5. Check the acidity of the oil that can "burn" the seals material. It will therefore destroy the elasticity of the sealing.
 - b-6. Check if the chosen seal (high pressure seal for example) is not too stiff for the use. If the environment requires some elasticity due to a gentle misalignment, a high pressure seal will not be able to follow the movement and therefore leak.

Power Take-Off Maintenance

Due to the normal and sometime severe torsional vibrations that Power Take-Off units experience, operators should follow a set maintenance schedule for inspections. Failure to service loose bolts or Power Take-Off leaks could result in potential auxiliary Power Take-Off or transmission damage.

Periodic P.T.O. MAINTENANCE is required by the owner/operator to ensure proper, safe and trouble free operation.

Daily: Check all air, hydraulic and working mechanisms before operating P.T.O. Perform maintenance as required.

Monthly: Inspect for possible leaks and tighten all air, hydraulic and mounting hardware, if necessary. Torque all bolts, nuts, etc. to Chelsea specifications. Ensure that splines are properly lubricated, if applicable. Perform maintenance as required.

With regards to the direct mounted pump splines, the P.T.O. requires the application of a specially formulated anti-fretting, high pressure, high temperature grease. The addition of the grease has been proven to reduce the effects of the torsional vibrations, which result in fretting corrosion on the P.T.O. internal splines as well as the pump external splines. Fretting corrosion appears as a "rusting and wearing" of the pump shaft splines. Severe duty applications, which require long P.T.O. running times and high torque may require more frequent regreasing. Applications such as Utility Trucks that run continuously and are lightly loaded also require frequent regreasing due to the sheer hours of running time. It is important to note that service intervals will vary for each and every application and is the responsibility of the end user of the product. Chelsea also recommends that you consult your pump owners manuals and technical services for their maintenance guidelines. Fretting corrosion is caused by many factors and without proper maintenance; the anti-fretting grease can only reduce its effects on components.

Chelsea offers the grease to our customers in two packages. The first is a 5/8 fluid ounce tube (379688), which is included with every applicable P.T.O., and the second is a 14-ounce grease cartridge (379831). Chelsea also offers greaseable shafts for most all output designators.

Warranty: Failure to comply entirely with the provisions set forth in the appropriate Owner's Manual will result in voiding of ALL Warranty consideration.

Offer of Sale

The items described in this document and other documents and descriptions provided by Parker Hannifin Corporation, its subsidiaries and its authorized distributors ("Seller") are hereby offered for sale at prices to be established by Seller. This offer and its acceptance by any customer ("Buyer") shall be governed by all of the following Terms and Conditions. Buyer's order for any item described in its document, when communicated to Seller verbally, or in writing, shall constitute acceptance of this offer. All goods, services or work described will be referred to as "Products".

1. Terms and Conditions. Seller's willingness to offer Products, or accept an order for Products, to or from Buyer is subject to these Terms and Conditions or any newer version of the terms and conditions found on-line at www.parker.com/saleterms/. Seller objects to any contrary or additional terms or conditions of Buyer's order or any other document issued by Buyer.

2. Price Adjustments; Payments. Prices stated on Seller's quote or other documentation offered by Seller are valid for 30 days, and do not include any sales, use, or other taxes unless specifically stated. Unless otherwise specified by Seller, all prices are F.C.A. Seller's facility (INCOTERMS 2010). Payment is subject to credit approval and is due 30 days from the date of invoice or such other term as required by Seller's Credit Department, after which Buyer shall pay interest on any unpaid invoices at the rate of 1.5% per month or the maximum allowable rate under applicable law.

3. Delivery Dates; Title and Risk; Shipment. All delivery dates are approximate and Seller shall not be responsible for any damages resulting from any delay. Regardless of the manner of shipment, title to any products and risk of loss or damage shall pass to Buyer upon placement of the products with the shipment carrier at Seller's facility. Unless otherwise stated, Seller may exercise its judgment in choosing the carrier and means of delivery. No deferment of shipment at Buyer's request beyond the respective dates indicated will be made except on terms that will indemnify, defend and hold Seller harmless against all loss and additional expense. Buyer shall be responsible for any additional shipping charges incurred by Seller due to Buyer's acts or omissions.

4. Warranty. Seller warrants that all products sold, other than the 590 Series, conform to the applicable Parker Chelsea standard specification for the lesser period of 2 years (24 Months) from date of service or 2-1/2 years (30 Months) from date of build (as marked on the product name plate). Seller warrants that the 590 Series will conform to the applicable Seller standard specification for the lesser period of 2 years (24 Months) from date of service or 2000 hours of usage. The prices charged for Seller's products are based upon the exclusive limited warranty stated above, and upon the following disclaimer: **DISCLAIMER OF WARRANTY: THIS WARRANTY COMPRISES THE SOLE AND ENTIRE WARRANTY PERTAINING TO PRODUCTS PROVIDED HEREUNDER. SELLER DISCLAIMS ALL OTHER WARRANTIES, EXPRESS AND IMPLIED, INCLUDING DESIGN, MERCHANTABILITY AND FITNESS FOR A PARTICULAR PURPOSE.**

5. Claims; Commencement of Actions. Buyer shall promptly inspect all Products upon delivery. No claims for shortages will be allowed unless reported to the Seller within 10 days of delivery. No other claims against Seller will be allowed unless asserted in writing within 30 days after delivery. Buyer shall notify Seller of any alleged breach of warranty within 30 days after the date the defect is or should have been discovered by Buyer. Any action based upon breach of this agreement or upon any other claim arising out of this sale (other than an action by Seller for an amount due on any invoice) must be commenced within 12 months from the date of the breach without regard to the date breach is discovered.

6. LIMITATION OF LIABILITY. UPON NOTIFICATION, SELLER WILL, AT ITS OPTION, REPAIR OR REPLACE A DEFECTIVE PRODUCT, OR REFUND THE PURCHASE PRICE. IN NO EVENT SHALL SELLER BE LIABLE TO BUYER FOR ANY SPECIAL, INDIRECT, INCIDENTAL OR CONSEQUENTIAL DAMAGES ARISING OUT OF, OR AS THE RESULT OF, THE SALE, DELIVERY, NON-DELIVERY, SERVICING, USE OR LOSS OF USE OF THE PRODUCTS OR ANY PART THEREOF, OR FOR ANY CHARGES OR EXPENSES OF ANY NATURE INCURRED WITHOUT SELLER'S WRITTEN CONSENT, EVEN IF SELLER HAS BEEN NEGLIGENT, WHETHER IN CONTRACT, TORT OR OTHER LEGAL THEORY. IN NO EVENT SHALL SELLER'S LIABILITY UNDER ANY CLAIM MADE BY BUYER EXCEED THE PURCHASE PRICE OF THE PRODUCTS.

7. User Responsibility. The user, through its own analysis and testing, is solely responsible for making the final selection of the system and Product and assuring that all performance, endurance, maintenance, safety and warning requirements of the application are met. The user must analyze all aspects of the application and follow applicable industry standards and Product information. If Seller provides Product or system options, the user is responsible for determining that such data and specifications are suitable and sufficient for all applications and reasonably foreseeable uses of the Products or systems.

8. Loss to Buyer's Property. Any designs, tools, patterns, materials, drawings, confidential information or equipment furnished by Buyer or any other items which become Buyer's property, will be considered obsolete and may be destroyed by Seller after two consecutive years have elapsed without Buyer ordering the items manufactured using such property. Seller shall not be responsible for any loss or damage to such property while it is in Seller's possession or control.

9. Special Tooling. A tooling charge may be imposed for any special tooling, including without limitation, dies, fixtures, molds and patterns, acquired to manufacture Products. Such special tooling shall be and remain Seller's property notwithstanding payment of any charges by Buyer. In no event will Buyer acquire any interest in apparatus belonging to Seller which is utilized in the manufacture of the Products, even if such apparatus has been specially converted or adapted for such manufacture and notwithstanding any charges paid by Buyer. Unless otherwise agreed, Seller shall have the right to alter, discard or otherwise dispose of any special tooling or other property in its sole discretion at any time.

10. Buyer's Obligation; Rights of Seller. To secure payment of all sums due or otherwise, Seller shall retain a security interest in the goods delivered and this agreement shall be deemed a Security Agreement under the Uniform Commercial Code. Buyer authorizes Seller as its attorney to execute and file on Buyer's behalf all documents Seller deems necessary to perfect its security interest.

Offer of Sale (continued)

11. Improper use and Indemnity. Buyer shall indemnify, defend, and hold Seller harmless from any claim, liability, damages, lawsuits, and costs (including attorney fees), whether for personal injury, property damage, patent, trademark or copyright infringement or any other claim, brought by or incurred by Buyer, Buyer's employees, or any other person, arising out of: (a) improper selection, improper application or other misuse of Products purchased by Buyer from Seller; (b) any act or omission, negligent or otherwise, of Buyer; (c) Seller's use of patterns, plans, drawings, or specifications furnished by Buyer to manufacture Product; or (d) Buyer's failure to comply with these terms and conditions. Seller shall not indemnify Buyer under any circumstance except as otherwise provided.

12. Cancellations and Changes. Orders shall not be subject to cancellation or change by Buyer for any reason, except with Seller's written consent and upon terms that will indemnify, defend and hold Seller harmless against all direct, incidental and consequential loss or damage. Seller may change product features, specifications, designs and availability with notice to Buyer.

13. Limitation on Assignment. Buyer may not assign its rights or obligations under this agreement without the prior written consent of Seller.

14. Force Majeure. Seller does not assume the risk and shall not be liable for delay or failure to perform any of Seller's obligations by reason of circumstances beyond the reasonable control of Seller (hereinafter "Events of Force Majeure"). Events of Force Majeure shall include without limitation: accidents, strikes or labor disputes, acts of any government or government agency, acts of nature, delays or failures in delivery from carriers or suppliers, shortages of materials, or any other cause beyond Seller's reasonable control.

15. Waiver and Severability. Failure to enforce any provision of this agreement will not waive that provision nor will any such failure prejudice Seller's right to enforce that provision in the future. Invalidation of any provision of this agreement by legislation or other rule of law shall not invalidate any other provision herein. The remaining provisions of this agreement will remain in full force and effect.

16. Termination. Seller may terminate this agreement for any reason and at any time by giving Buyer thirty (30) days written notice of termination. Seller may immediately terminate this agreement, in writing, if Buyer: (a) commits a breach of any provision of this agreement (b) appoints a trustee, receiver or custodian for all or any part of Buyer's property (c) files a petition for relief in bankruptcy on its own behalf, or by a third party (d) makes an assignment for the benefit of creditors, or (e) dissolves or liquidates all or a majority of its assets.

17. Governing Law. This agreement and the sale and delivery of all Products hereunder shall be deemed to have taken place in and shall be governed and construed in accordance with the laws of the State of Ohio, as applicable to contracts executed and wholly performed therein and without regard to conflicts of laws principles. Buyer irrevocably agrees and consents to the exclusive jurisdiction and venue of the courts of Cuyahoga County, Ohio with respect to any dispute, controversy or claim arising out of or relating to this agreement.

18. Indemnity for Infringement of Intellectual Property Rights. Seller shall have no liability for infringement of any patents, trademarks, copyrights, trade dress, trade secrets or similar rights except as provided in this Section. Seller will defend and indemnify Buyer against allegations of infringement of U.S. patents, U.S. trademarks, copyrights, trade dress and trade secrets ("Intellectual Property Rights"). Seller will defend at its expense and will pay the cost of any settlement or damages awarded in an action brought against Buyer based on an allegation that a Product sold pursuant to this Agreement infringes the Intellectual Property Rights of a third party. Seller's obligation to defend and indemnify Buyer is contingent on Buyer notifying Seller within ten (10) days after Buyer becomes aware of such allegations of infringement, and Seller having sole control over the defense of any allegations or actions including all negotiations for settlement or compromise. If a Product is subject to a claim that it infringes the Intellectual Property Rights of a third party, Seller may, at its sole expense and option, procure for Buyer the right to continue using the Product, replace or modify the Product so as to make it noninfringing, or offer to accept return of the Product and return the purchase price less a reasonable allowance for depreciation. Notwithstanding the foregoing, Seller shall have no liability for claims of infringement based on information provided by Buyer, or directed to Products delivered hereunder for which the designs are specified in whole or part by Buyer, or infringements resulting from the modification, combination or use in a system of any Product sold hereunder. The foregoing provisions of this Section shall constitute Seller's sole and exclusive liability and Buyer's sole and exclusive remedy for infringement of Intellectual Property Rights.

19. Entire Agreement. This agreement contains the entire agreement between the Buyer and Seller and constitutes the final, complete and exclusive expression of the terms of sale. All prior or contemporaneous written or oral agreements or negotiations with respect to the subject matter are herein merged.

20. Compliance with Law, U.K. Bribery Act and U.S. Foreign Corrupt Practices Act. Buyer agrees to comply with all applicable laws and regulations, including both those of the United Kingdom and the United States of America, and of the country or countries of the Territory in which Buyer may operate, including without limitation the U. K. Bribery Act, the U.S. Foreign Corrupt Practices Act ("FCPA") and the U.S. Anti-Kickback Act (the "Anti-Kickback Act"), and agrees to indemnify and hold harmless Seller from the consequences of any violation of such provisions by Buyer, its employees or agents. Buyer acknowledges that they are familiar with the provisions of the U. K. Bribery Act, the FCPA and the Anti-Kickback Act, and certifies that Buyer will adhere to the requirements thereof. In particular, Buyer represents and agrees that Buyer shall not make any payment or give anything of value, directly or indirectly to any governmental official, any foreign political party or official thereof, any candidate for foreign political office, or any commercial entity or person, for the purpose of influencing such person to purchase products or otherwise benefit the business of Seller.

07/14

Parker Worldwide

Europe, Middle East, Africa

AE – United Arab Emirates, Dubai

Tel: +971 4 8127100
parker.me@parker.com

AT – Austria, Wiener Neustadt

Tel: +43 (0)2622 23501-0
parker.austria@parker.com

AT – Eastern Europe, Wiener Neustadt

Tel: +43 (0)2622 23501 900
parker.easteurope@parker.com

AZ – Azerbaijan, Baku

Tel: +994 50 22 33 458
parker.azerbaijan@parker.com

BE/LU – Belgium, Nivelles

Tel: +32 (0)67 280 900
parker.belgium@parker.com

BG – Bulgaria, Sofia

Tel: +359 2 980 1344
parker.bulgaria@parker.com

BY – Belarus, Minsk

Tel: +375 17 209 9399
parker.belarus@parker.com

CH – Switzerland, Etoy

Tel: +41 (0)21 821 87 00
parker.switzerland@parker.com

CZ – Czech Republic, Klecany

Tel: +420 284 083 111
parker.czechrepublic@parker.com

DE – Germany, Kaarst

Tel: +49 (0)2131 4016 0
parker.germany@parker.com

DK – Denmark, Ballerup

Tel: +45 43 56 04 00
parker.denmark@parker.com

ES – Spain, Madrid

Tel: +34 902 330 001
parker.spain@parker.com

FI – Finland, Vantaa

Tel: +358 (0)20 753 2500
parker.finland@parker.com

FR – France, Contamine s/Arve

Tel: +33 (0)4 50 25 80 25
parker.france@parker.com

GR – Greece, Athens

Tel: +30 210 933 6450
parker.greece@parker.com

HU – Hungary, Budaoers

Tel: +36 23 885 470
parker.hungary@parker.com

IE – Ireland, Dublin

Tel: +353 (0)1 466 6370
parker.ireland@parker.com

IT – Italy, Corisico (MI)

Tel: +39 02 45 19 21
parker.italy@parker.com

KZ – Kazakhstan, Almaty

Tel: +7 7273 561 000
parker.easteurope@parker.com

NL – The Netherlands, Oldenzaal

Tel: +31 (0)541 585 000
parker.nl@parker.com

NO – Norway, Asker

Tel: +47 66 75 34 00
parker.norway@parker.com

PL – Poland, Warsaw

Tel: +48 (0)22 573 24 00
parker.poland@parker.com

PT – Portugal, Leca de Palmeira

Tel: +351 22 999 7360
parker.portugal@parker.com

RO – Romania, Bucharest

Tel: +40 21 252 1382
parker.romania@parker.com

RU – Russia, Moscow

Tel: +7 495 645-2156
parker.russia@parker.com

SE – Sweden, Spånga

Tel: +46 (0)8 59 79 50 00
parker.sweden@parker.com

SK – Slovakia, Banská Bystrica

Tel: +421 484 162 252
parker.slovakia@parker.com

SL – Slovenia, Novo Mesto

Tel: +386 7 337 6650
parker.slovenia@parker.com

TR – Turkey, Istanbul

Tel: +90 216 4997081
parker.turkey@parker.com

UA – Ukraine, Kiev

Tel: +380 44 494 2731
parker.ukraine@parker.com

UK – United Kingdom, Warwick

Tel: +44 (0)1926 317 878
parker.uk@parker.com

ZA – South Africa, Kempton Park

Tel: +27 (0)11 961 0700
parker.southafrica@parker.com

North America

CA – Canada, Milton, Ontario

Tel: +1 905 693 3000

MX – Mexico, Toluca

Tel: +52 72 2275 4200

Asia Pacific

AU – Australia, Castle Hill

Tel: +61 (0)2-9634 7777

CN – China, Shanghai

Tel: +86 21 2899 5000

HK – Hong Kong

Tel: +852 2428 8008

IN – India, Mumbai

Tel: +91 22 6513 7081-85

JP – Japan, Fujisawa

Tel: +81 (0)4 6635 3050

KR – South Korea, Seoul

Tel: +82 2 559 0400

MY – Malaysia, Shah Alam

Tel: +60 3 7849 0800

NZ – New Zealand, Mt Wellington

Tel: +64 9 574 1744

SG – Singapore

Tel: +65 6887 6300

TH – Thailand, Bangkok

Tel: +662 717 8140

TW – Taiwan, New Taipei City

Tel: +886 2 2298 8987

South America

AR – Argentina, Buenos Aires

Tel: +54 3327 44 4129

BR – Brazil, Cachoeirinha RS

Tel: +55 51 3470 9144

CL – Chile, Santiago

Tel: +56 2 623 1216

Pan Am, Miami

Tel: +1 305-470-8800

Parker Hannifin Corporation

Chelsea Products Division
8225 Hacks Cross Road
Olive Branch, Mississippi 38654 USA
Tel: (662) 895-1011
Fax: (662) 895-1069
www.parker.com/chelsea

