

Chelsea® 523 Series

Two Gear Mechanically Shifted
Rear Mount P.T.O.



Overview:

The two gear designed rear mount P.T.O. provides a compact housing which helps eliminate clearance issues along with two speed ratios to meet your application requirements. High capacity bearings and superior gear designs provide torque ratings up to 260 Lbs. ft. or 350 N.m. for the ultimate performance. The superior design of this P.T.O. provides all the power you will need so there is no need to de-rate the P.T.O. for continuous applications. The 523 has 18 mounting adapters that allow it to fit on 133 transmissions and features four shift options integrated into the P.T.O. housing for a space saving design. The Cam lock shift mechanism provides a positive engagement for each shift cycle. The 3 direct mount pump flange options come standard with our Wet Spline design that provides increased P.T.O. and pump shaft life. Versatility, power, ease of maintenance and installation make the 523 Series the only choice for your vocational truck requirements.



- Fire
- Refuse
- Aerial
- Sewer and Sanitation
- Tippers

Product Features and Benefits:

Contact Information:

Parker Hannifin Corporation
Chelsea Products Division
8225 Hacks Cross Road
Olive Branch, MS 38654 USA

Phone: 1-888-PH4-TRUK
(1-888-744-8785)

Fax: 1-662-895-1069
chelseacustserv@parker.com

www.parker.com/chelsea

- Continuous torque rating of 350 N.m. or 260 Lbs. ft.
- Rear mount design - requires less mounting space and simplifies installation.
- No gear back lash to set - simplifying installation.
- Wet Spline outputs - Extend P.T.O. and Pump Shaft Life. Eliminates the need to disassemble to grease the mating Pump and P.T.O. shafts.
- 3 Direct mount pump options.
- 5 Shift Options.



ENGINEERING YOUR SUCCESS.

523 SERIES POWER TAKE-OFF SPECIFICATIONS AND TECHNICAL DATA

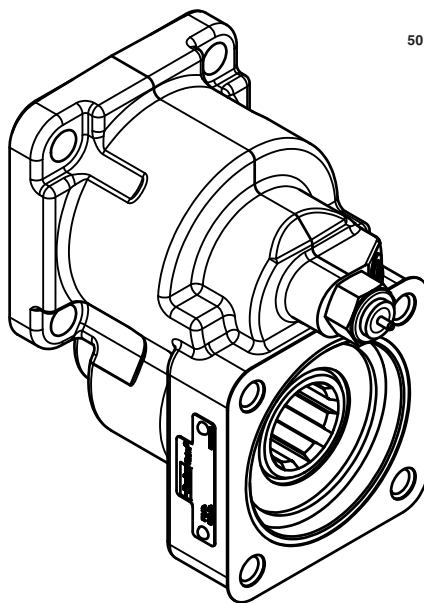
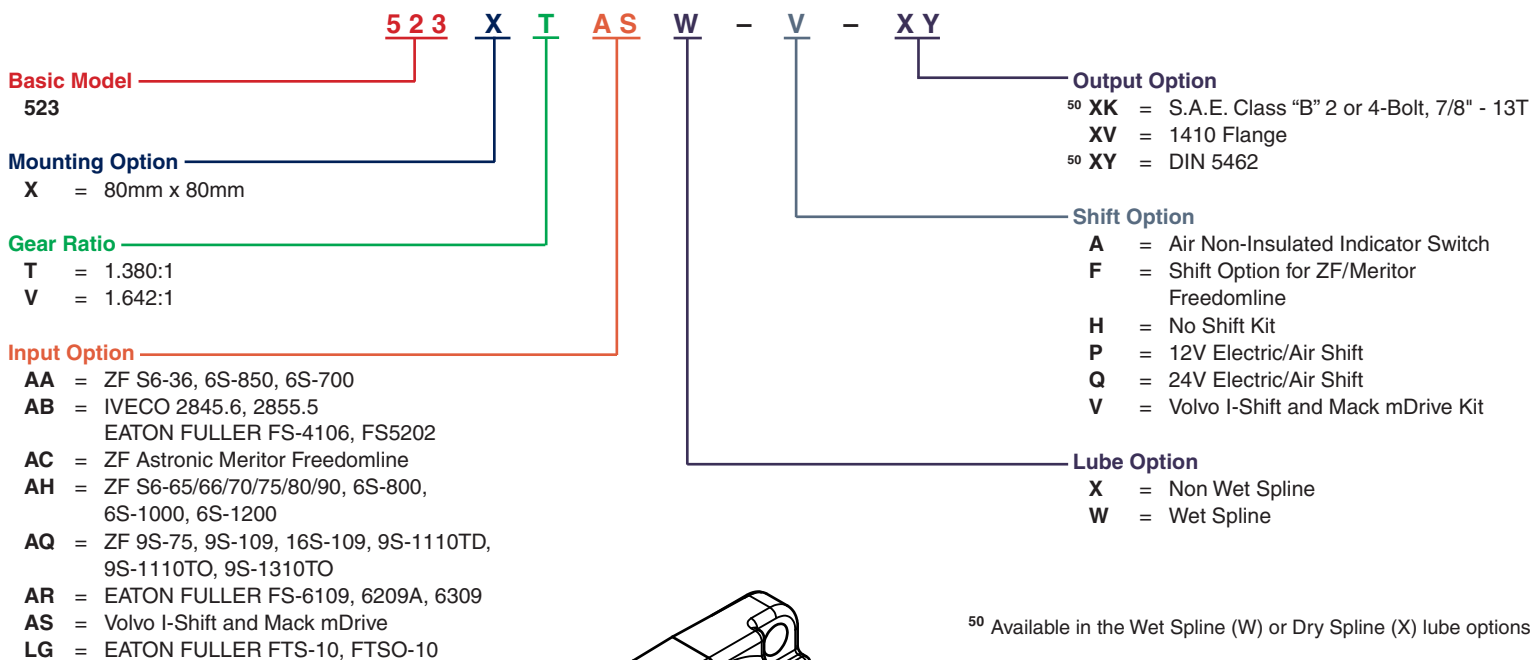

Specifications Chart

	523*T	523*V
Standard Output Shaft Size	4-Bolt DIN 5462	
Intermittent & Continuous Torque Rating (Lbs. ft.)	258	258
Intermittent & Continuous Torque Rating (N.m.)	350	350
Horsepower Rating for Intermittent & Continuous Service		
At 500 R.P.M. of Output Shaft (HP)	25	25
At 1000 R.P.M. of Output Shaft (HP)	49	49
At 500 R.P.M. of Output Shaft (Kw)	18	18
At 1000 R.P.M. of Output Shaft (Kw)	37	37
Approximate Weight:	12.0 lbs. [5.4 kg]	

© 2015 Parker Hannifin Corporation

Supercedes HY25-0155-B1/US September 2014 HY25-0155-B1/US January 2015



ENGINEERING YOUR SUCCESS.