

CHELSEA[®]

Bulletin HY25-2560-M1/US

Parts List 560V Series

Effective: August 16, 2012

Supersedes: HY25-2560-M1/US July 16, 2012





WARNING — User Responsibility

FAILURE OR IMPROPER SELECTION OR IMPROPER USE OF THE PRODUCTS DESCRIBED HEREIN OR RELATED ITEMS CAN CAUSE DEATH, PERSONAL INJURY AND PROPERTY DAMAGE.

This document and other information from Parker-Hannifin Corporation, its subsidiaries and authorized distributors provide product or system options for further investigation by users having technical expertise.

The user, through its own analysis and testing, is solely responsible for making the final selection of the system and components and assuring that all performance, endurance, maintenance, safety and warning requirements of the application are met. The user must analyze all aspects of the application, follow applicable industry standards, and follow the information concerning the product in the current product catalog and in any other materials provided from Parker or its subsidiaries or authorized distributors.

To the extent that Parker or its subsidiaries or authorized distributors provide component or system options based upon data or specifications provided by the user, the user is responsible for determining that such data and specifications are suitable and sufficient for all applications and reasonably foreseeable uses of the components or systems.

Offer of Sale

The items described in this document are hereby offered for sale by Parker Hannifin Corporation, its subsidiaries or its authorized distributors. This offer and its acceptance are governed by the provisions stated in the "Offer of Sale".

© Copyright 2012, Parker Hannifin Corporation, All Rights Reserved

Contents

Exploded View	1
Bill of Materials	2-3
Housing Dimension	3
Model Number Designator.....	4
560 T6C Cartridge Chart.....	4
Kits Bill of Materials	5
Offer of Sale	8

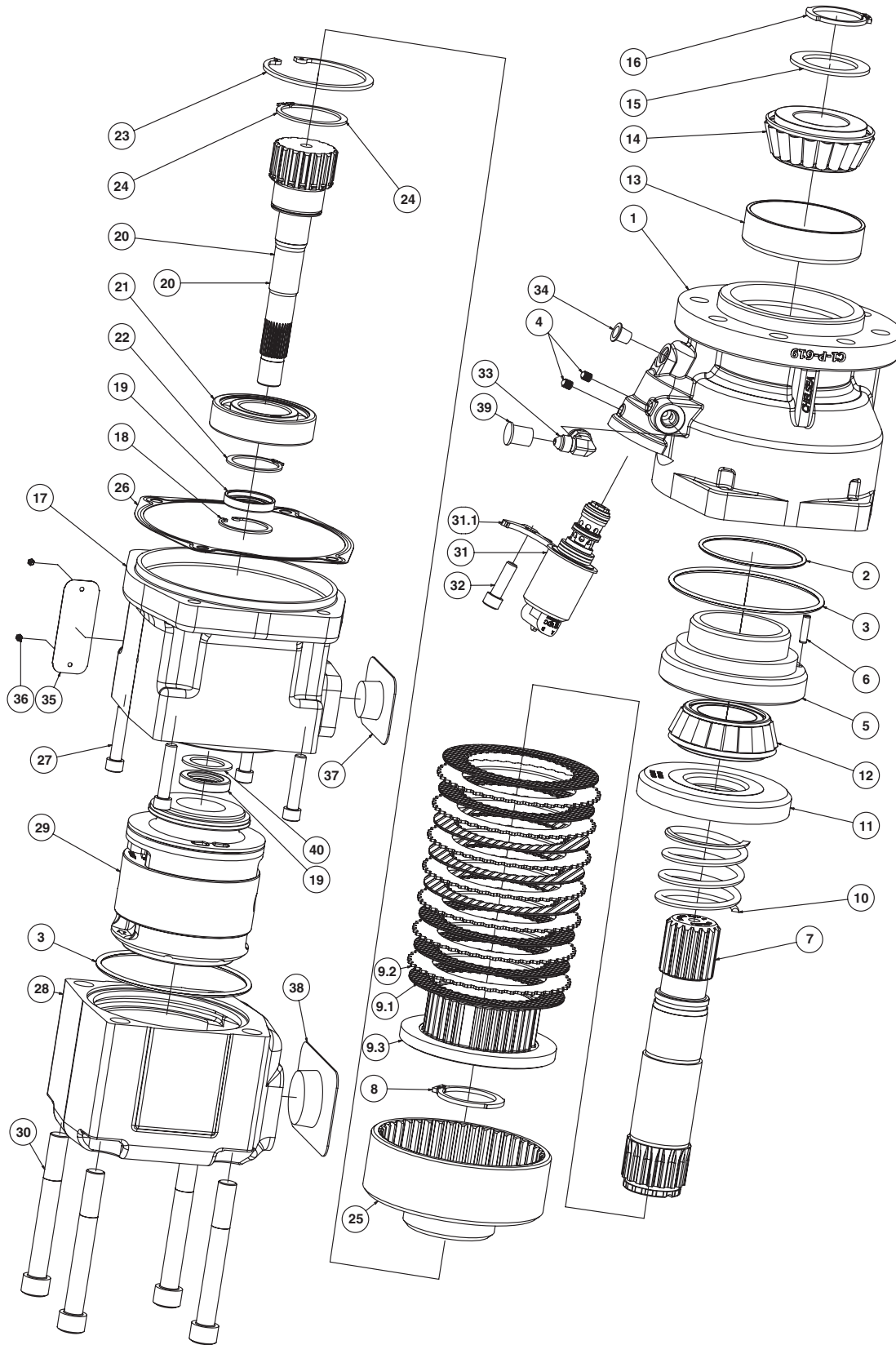

Bill of Materials

Item	Part Number	Description	Qty
1	1-P-620	Housing Input	1
2	28-P-284	O-Ring 2.737" x .103"	1
3	28-P-259	O-Ring 3.984" x .139"	2
4	380008	Plug Steel Ball & Sleeve	2
5	66-P-25	Piston Oil Actuated	1
6	500597-10	Pin Roll .188" x .750"	1
7	3-P-990	Shaft Input	1
8	379052	Lockring	1
9	329666X	Gear & Plates Kit	1
9.1	379485	Disc Friction	8
9.2	379595	Plate Clutch	7
9.3	2-P-858	Gear Output	1
10	37-P-39	Spring 2.552" x 1.985"	1
11	66-P-26	Plate Pressure	1
12	561022	Bearing Tapered Cone 1.625" x 1.010"	1
13	561024	Bearing Tapered Cup 3.251" x .906"	1
14	561023	Bearing Tapered Cone 1.500" x 1.164"	1
15	31-P-70	Washer Thrust 1.507" x 2.167" x .094"	1
16	379746	Lockring	1
17	21-P-780	Housing Pump Adapter	1
18	378849	Lockring	1
19	28-P-119	Oil Seal 1.379" x .875" x .250"	2
20	3-P-1087	Shaft Pump Drive	1
21	550010	Bearing Ball 1.378" x 2.8346" x .6693"	1
22	378098	Lockring	1
23	378895	Lockring	1
24	379668	Lockring	1
25	2-P-854	Clutch Bell	1
26	22-P-101	Gasket	1
27	378447-8	Capscrew SH .312" x 18" x 1.500"	4
28	380419-1	Pump Vane Housing	1
29	See Page 4	Pump Vane Cartridge	1
30	379435-17	Capscrew SH .500" x 13" x 4.000"	4
31	379993-12	Valve Cartridge Pressure Regulating 12V	1
	379993-24	Valve Cartridge Pressure Regulating 24V	1
31.1	379995	Clamp Included w/ 379993	1
32	378447-6	Capscrew SH .312" x 18" x 1.000"	1
33	379486	Elbow 90 Degree .438" x 20"	1
34	500897-5	Plug Shipping	1
35	68-P-51	Plate Name	1
36	378422	Screw Drive	2
37	380427-16	Cover S.A.E. 16 Split Flange	1
38	380427-24	Cover S.A.E. 24 Split Flange	1
39	379564-2	Cap Thread .438"	1
40	378811	Plate Seal Backup	1

Continued on Next Page

Bill of Materials

Item	Part Number	Description	Qty
		Loose Parts	
	7170-120X	Mounting & Stud Kit.....	1
	328948-29X	Installation Kit.....	1
	329443-12X	Installation Kit 12V.....	1
	329443-24X	Installation Kit 24V.....	1
	329075-1X	High Pressure Hose 25.0".....	1
		Service Parts	
	329071-56X	Bearing Kit.....	1
	329071-57X	Gasket & Seal Kit.....	1
	329071-58X	Clutch Repair Kit.....	1

Housing Dimension

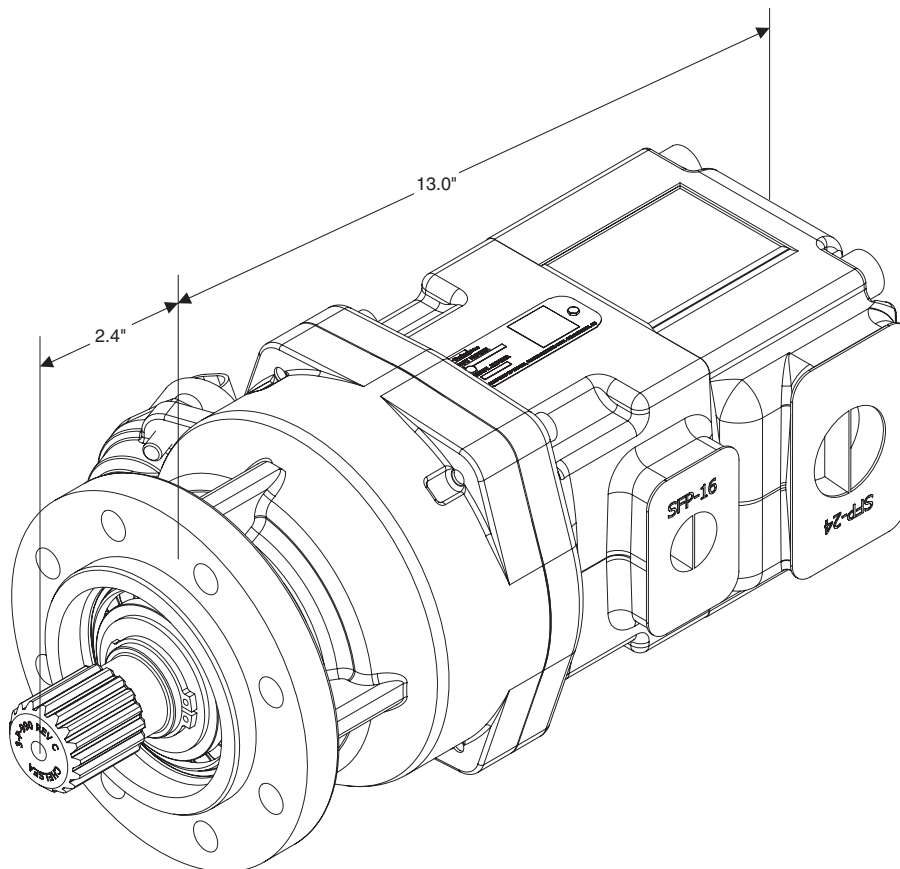

Model Number Designator

**Parts List
560V Series**

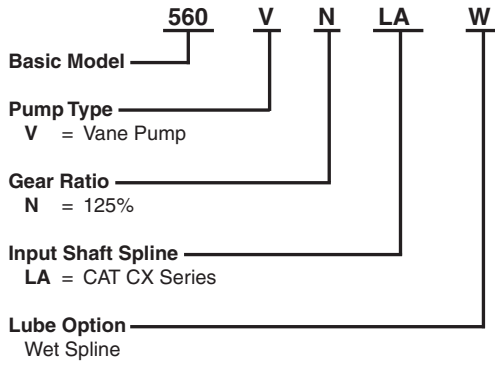

Pump Size

- 17 = B17 Cartridge 3.56 in³/rev
- 22 = B22 Cartridge 4.29 in³/rev
- 25 = B25 Cartridge 4.84 in³/rev
- 31 = B31 Cartridge 6.10 in³/rev

Assembly Arrangement

- 1 = Pressure Port 180° to Valve - Suction Port Inline w/ Pressure Port (Standard Assembly)
- 2 = Pressure Port 180° to Valve - Suction Port 90° CW from Pressure Port
- 3 = Pressure Port 180° to Valve - Suction Port 180° CW from Pressure Port
- 4 = Pressure Port 180° to Valve - Suction Port 270° CW from Pressure Port
- 5 = Pressure Port Inline to Valve - Suction Port Inline to Valve
- 6 = Pressure Port Inline to Valve - Suction Port 90° CW from Pressure Port
- 7 = Pressure Port Inline to Valve - Suction Port 180° CW from Pressure Port
- 8 = Pressure Port Inline to Valve - Suction Port 270° CW from Pressure Port

CW = Clock Wise Rotation When Viewed from the Rear

Shift Option

- B** = 12V Electric/Hydraulic
- D** = 24V Electric/Hydraulic

Chelsea 560 T6C Cartridge Chart

Model Code	Part Number	Vendor Description	Displacement In ³ /Rev
03	380418-03	Cartridge T6CM Unit B03 CCW S1	0.66"
05	380418-05	Cartridge T6CM Unit B05 CCW S1	1.05"
06	380418-06	Cartridge T6CM Unit B06 CCW S1	1.30"
08	380418-08	Cartridge T6CM Unit B08 CCW S1	1.61"
10	380418-10	Cartridge T6CM Unit B010 CCW S1	2.08"
12	380418-12	Cartridge T6CM Unit B012 CCW S1	2.26"
14	380418-14	Cartridge T6CM Unit B014 CCW S1	2.81"
17	380418-17	Cartridge T6CM Unit B017 CCW S1	3.56"
20	380418-20	Cartridge T6CM Unit B020 CCW S1	3.89"
22	380418-22	Cartridge T6CM Unit B022 CCW S1	4.29"
25	380418-25	Cartridge T6CM Unit B025 CCW S1	4.84"
28	380418-28	Cartridge T6CM Unit B028 CCW S1	5.42"
31	380418-31	Cartridge T6CM Unit B031 CCW S1	6.10"

Bxx = Cam Ring

CCW = Counter Clockwise

S1 = Seal Class (for Mineral Oil)

329071-56X	Bearing Kit	
500597-10	Pin Roll	1
561023	Bearing Tapered Cone.....	1
379668	Lockring	1
550010	Bearing Ball	1
379746	Lockring	1
379052	Lockring	1
561024	Bearing Tapered Cup.....	1
561022	Bearing Tapered Cone.....	1
66-P-25	Piston Oil Actuated.....	1
378098	Lockring	1

329071-57X	Gasket & Seal Kit	
22-P-101	Gasket	1
28-P-119	Oil Seal	2
28-P-259	O-Ring 3.984" x .139".....	2
379668	Lockring	1
378895	Lockring	1

329071-58X	Clutch Repair Kit	
379595	Clutch Plate	7
28-P-284	O-Ring 2.737" x .103".....	1
379746	Lockring	1
379485	Disc Friction.....	8
28-P-259	O-Ring 3.984" x .139".....	1
379052	Lockring	1

329443-12X	12 Volt Installation Kit	
378881	Rocker Switch.....	1
378978	Indicator.....	1
379252	Butt Connector.....	1
379257	Splice Connector	1
379265	Grommet.....	1
379306	Fork Connector.....	3
379336	Bracket Switch.....	1
379502	Pressure Switch.....	1
379928	Valve Connector	1
379900	Fuse Ass'y	1
379061X	Tie Wire	1

329443-24X	24 Volt Installation Kit	
378881	Rocker Switch.....	1
379005	Indicator.....	1
379252	Butt Connector.....	1
379257	Splice Connector	1
379265	Grommet.....	1
379306	Fork Connector.....	3
379336	Bracket Switch.....	1
379502	Pressure Switch.....	1
379928	Valve Connector	1
379900	Fuse Ass'y	1
379061X	Tie Wire	1

328948-29X	Installation Kit	
328946X	Caution Kit.....	1
28-P-259	O-Ring 3.984" x .139".....	1
379486	90 Degree Elbow	1
Owners Manual	HY25-1569-M1/US	1

7170-120X	Mounting/Stud Kit	
379745	Flange Nut .438" - 20	8
379429-22	Stud M12 - 1.75" x 2.250" x .438" - 20	8

Offer of Sale

The items described in this document and other documents and descriptions provided by Parker Hannifin Corporation, its subsidiaries and its authorized distributors ("Seller") are hereby offered for sale at prices to be established by Seller. This offer and its acceptance by any customer ("Buyer") shall be governed by all of the following Terms and Conditions. Buyer's order for any item described in its document, when communicated to Seller verbally, or in writing, shall constitute acceptance of this offer. All goods, services or work described will be referred to as "Products".

1. Terms and Conditions. Seller's willingness to offer Products, or accept an order for Products, to or from Buyer is subject to these Terms and Conditions or any newer version of the terms and conditions found on-line at www.parker.com/saleterms/. Seller objects to any contrary or additional terms or conditions of Buyer's order or any other document issued by Buyer.

2. Price Adjustments; Payments. Prices stated on Seller's quote or other documentation offered by Seller are valid for 30 days, and do not include any sales, use, or other taxes unless specifically stated. Unless otherwise specified by Seller, all prices are F.C.A. Seller's facility (INCOTERMS 2010). Payment is subject to credit approval and is due 30 days from the date of invoice or such other term as required by Seller's Credit Department, after which Buyer shall pay interest on any unpaid invoices at the rate of 1.5% per month or the maximum allowable rate under applicable law.

3. Delivery Dates; Title and Risk; Shipment. All delivery dates are approximate and Seller shall not be responsible for any damages resulting from any delay. Regardless of the manner of shipment, title to any products and risk of loss or damage shall pass to Buyer upon placement of the products with the shipment carrier at Seller's facility. Unless otherwise stated, Seller may exercise its judgment in choosing the carrier and means of delivery. No deferment of shipment at Buyer's request beyond the respective dates indicated will be made except on terms that will indemnify, defend and hold Seller harmless against all loss and additional expense. Buyer shall be responsible for any additional shipping charges incurred by Seller due to Buyer's acts or omissions.

4. Warranty. Parker Chelsea warrants that all products sold conform to the applicable Parker Chelsea standard specification for the lesser period of: 2 years (24 Months) from Date of service or 2-1/2 years(30 Months) from date of build (as marked on the product name plate). The prices charged for Seller's products are based upon the exclusive limited warranty stated above, and upon the following disclaimer: **DISCLAIMER OF WARRANTY: THIS WARRANTY COMPRISES THE SOLE AND ENTIRE WARRANTY PERTAINING TO PRODUCTS PROVIDED HEREUNDER. SELLER DISCLAIMS ALL OTHER WARRANTIES, EXPRESS AND IMPLIED, INCLUDING DESIGN, MERCHANTABILITY AND FITNESS FOR A PARTICULAR PURPOSE.**

5. Claims; Commencement of Actions. Buyer shall promptly inspect all Products upon delivery. No claims for shortages will be allowed unless reported to the Seller within 10 days of delivery. No other claims against Seller will be allowed unless asserted in writing within 30 days after delivery. Buyer shall notify Seller of any alleged breach of warranty within 30 days after the date the defect is or should have been discovered by Buyer. Any action based upon breach of this agreement or upon any other claim arising out of this sale (other than an action by Seller for an amount due on any invoice) must be commenced within 12 months from the date of the breach without regard to the date breach is discovered.

6. LIMITATION OF LIABILITY. UPON NOTIFICATION, SELLER WILL, AT ITS OPTION, REPAIR OR REPLACE A DEFECTIVE PRODUCT, OR REFUND THE PURCHASE PRICE. IN NO EVENT SHALL SELLER BE LIABLE TO BUYER FOR ANY SPECIAL, INDIRECT, INCIDENTAL OR CONSEQUENTIAL DAMAGES ARISING OUT OF, OR AS THE RESULT OF, THE SALE, DELIVERY, NON-DELIVERY, SERVICING, USE OR LOSS OF USE OF THE PRODUCTS OR ANY PART THEREOF, OR FOR ANY CHARGES OR EXPENSES OF ANY NATURE INCURRED WITHOUT SELLER'S WRITTEN CONSENT, EVEN IF SELLER HAS BEEN NEGLIGENT, WHETHER IN CONTRACT, TORT OR OTHER LEGAL THEORY. IN NO EVENT SHALL SELLER'S LIABILITY UNDER ANY CLAIM MADE BY BUYER EXCEED THE PURCHASE PRICE OF THE PRODUCTS.

7. User Responsibility. The user, through its own analysis and testing, is solely responsible for making the final selection of the system and Product and assuring that all performance, endurance, maintenance, safety and warning requirements of the application are met. The user must analyze all aspects of the application and follow applicable industry standards and Product information. If Seller provides Product or system options, the user is responsible for determining that such data and specifications are suitable and sufficient for all applications and reasonably foreseeable uses of the Products or systems.

8. Loss to Buyer's Property. Any designs, tools, patterns, materials, drawings, confidential information or equipment furnished by Buyer or any other items which become Buyer's property, will be considered obsolete and may be destroyed by Seller after two consecutive years have elapsed without Buyer ordering the items manufactured using such property. Seller shall not be responsible for any loss or damage to such property while it is in Seller's possession or control.

9. Special Tooling. A tooling charge may be imposed for any special tooling, including without limitation, dies, fixtures, molds and patterns, acquired to manufacture Products. Such special tooling shall be and remain Seller's property notwithstanding payment of any charges by Buyer. In no event will Buyer acquire any interest in apparatus belonging to Seller which is utilized in the manufacture of the Products, even if such apparatus has been specially converted or adapted for such manufacture and notwithstanding any charges paid by Buyer. Unless otherwise agreed, Seller shall have the right to alter, discard or otherwise dispose of any special tooling or other property in its sole discretion at any time.

10. Buyer's Obligation; Rights of Seller. To secure payment of all sums due or otherwise, Seller shall retain a security interest in the goods delivered and this agreement shall be deemed a Security Agreement under the Uniform Commercial Code. Buyer authorizes Seller as its attorney to execute and file on Buyer's behalf all documents Seller deems necessary to perfect its security interest.

11. Improper use and Indemnity. Buyer shall indemnify, defend, and hold Seller harmless from any claim, liability, damages, lawsuits, and costs (including attorney fees), whether for personal injury, property damage, patent, trademark or copyright infringement or any other claim, brought by or incurred by Buyer, Buyer's employees, or any other person, arising out of: (a) improper selection, improper application or other misuse of Products purchased by Buyer from Seller; (b) any act or omission, negligent or otherwise, of Buyer; (c) Seller's use of patterns, plans, drawings, or specifications furnished by Buyer to manufacture Product; or (d) Buyer's failure to comply with these terms and conditions. Seller shall not indemnify Buyer under any circumstance except as otherwise provided.

12. Cancellations and Changes. Orders shall not be subject to cancellation or change by Buyer for any reason, except with Seller's written consent and upon terms that will indemnify, defend and hold Seller harmless against all direct, incidental and consequential loss or damage. Seller may change product features, specifications, designs and availability with notice to Buyer.

13. Limitation on Assignment. Buyer may not assign its rights or obligations under this agreement without the prior written consent of Seller.

14. Force Majeure. Seller does not assume the risk and shall not be liable for delay or failure to perform any of Seller's obligations by reason of circumstances beyond the reasonable control of Seller (hereinafter "Events of Force Majeure"). Events of Force Majeure shall include without limitation: accidents, strikes or labor disputes, acts of any government or government agency, acts of nature, delays or failures in delivery from carriers or suppliers, shortages of materials, or any other cause beyond Seller's reasonable control.

15. Waiver and Severability. Failure to enforce any provision of this agreement will not waive that provision nor will any such failure prejudice Seller's right to enforce that provision in the future. Invalidation of any provision of this agreement by legislation or other rule of law shall not invalidate any other provision herein. The remaining provisions of this agreement will remain in full force and effect.

16. Termination. Seller may terminate this agreement for any reason and at any time by giving Buyer thirty (30) days written notice of termination. Seller may immediately terminate this agreement, in writing, if Buyer: (a) commits a breach of any provision of this agreement (b) appoints a trustee, receiver or custodian for all or any part of Buyer's property (c) files a petition for relief in bankruptcy on its own behalf, or by a third party (d) makes an assignment for the benefit of creditors, or (e) dissolves or liquidates all or a majority of its assets.

17. Governing Law. This agreement and the sale and delivery of all Products hereunder shall be deemed to have taken place in and shall be governed and construed in accordance with the laws of the State of Ohio, as applicable to contracts executed and wholly performed therein and without regard to conflicts of laws principles. Buyer irrevocably agrees and consents to the exclusive jurisdiction and venue of the courts of Cuyahoga County, Ohio with respect to any dispute, controversy or claim arising out of or relating to this agreement.

18. Indemnity for Infringement of Intellectual Property Rights. Seller shall have no liability for infringement of any patents, trademarks, copyrights, trade dress, trade secrets or similar rights except as provided in this Section. Seller will defend and indemnify Buyer against allegations of infringement of U.S. patents, U.S. trademarks, copyrights, trade dress and trade secrets ("Intellectual Property Rights"). Seller will defend at its expense and will pay the cost of any settlement or damages awarded in an action brought against Buyer based on an allegation that a Product sold pursuant to this Agreement infringes the Intellectual Property Rights of a third party. Seller's obligation to defend and indemnify Buyer is contingent on Buyer notifying Seller within ten (10) days after Buyer becomes aware of such allegations of infringement, and Seller having sole control over the defense of any allegations or actions including all negotiations for settlement or compromise. If a Product is subject to a claim that it infringes the Intellectual Property Rights of a third party, Seller may, at its sole expense and option, procure for Buyer the right to continue using the Product, replace or modify the Product so as to make it noninfringing, or offer to accept return of the Product and return the purchase price less a reasonable allowance for depreciation. Notwithstanding the foregoing, Seller shall have no liability for claims of infringement based on information provided by Buyer, or directed to Products delivered hereunder for which the designs are specified in whole or part by Buyer, or infringements resulting from the modification, combination or use in a system of any Product sold hereunder. The foregoing provisions of this Section shall constitute Seller's sole and exclusive liability and Buyer's sole and exclusive remedy for infringement of Intellectual Property Rights.

19. Entire Agreement. This agreement contains the entire agreement between the Buyer and Seller and constitutes the final, complete and exclusive expression of the terms of sale. All prior or contemporaneous written or oral agreements or negotiations with respect to the subject matter are herein merged.

20. Compliance with Law, U. K. Bribery Act and U.S. Foreign Corrupt Practices Act. Buyer agrees to comply with all applicable laws and regulations, including both those of the United Kingdom and the United States of America, and of the country or countries of the Territory in which Buyer may operate, including without limitation the U. K. Bribery Act, the U.S. Foreign Corrupt Practices Act ("FCPA") and the U.S. Anti-Kickback Act (the "Anti-Kickback Act"), and agrees to indemnify and hold harmless Seller from the consequences of any violation of such provisions by Buyer, its employees or agents. Buyer acknowledges that they are familiar with the provisions of the U. K. Bribery Act, the FCPA and the Anti-Kickback Act, and certifies that Buyer will adhere to the requirements thereof. In particular, Buyer represents and agrees that Buyer shall not make any payment or give anything of value, directly or indirectly to any governmental official, any foreign political party or official thereof, any candidate for foreign political office, or any commercial entity or person, for the purpose of influencing such person to purchase products or otherwise benefit the business of Seller.

02/12



Parker Hannifin Corporation
Chelsea Products Division
8225 Hacks Cross Road
Olive Branch, Mississippi 38654 USA
Tel: (662) 895-1011
Fax: (662) 890-5379
www.parker.com/chelsea

BLI 09/12 20C

