



HY13-1597-01/US

# 3Z Motor Series Service Procedure

Effective: September 2020

---



## 3ZG Low Speed, High Torque Hydraulic Motors

---

 **WARNING**

This product can expose you to chemicals including lead and DEHP, which are known to the State of California to cause cancer, and birth defects or other reproductive harm. For more information go to [www.p65warnings.ca.gov](http://www.p65warnings.ca.gov)

 **WARNING**

FAILURE OR IMPROPER SELECTION OR IMPROPER USE OF THE PRODUCTS AND/OR SYSTEMS DESCRIBED HEREIN OR RELATED ITEMS CAN CAUSE DEATH, PERSONAL INJURY AND PROPERTY DAMAGE.

This document and other information from Parker Hannifin Corporation, its subsidiaries and authorized distributors provide product and/or system options for further investigation by users having technical expertise. It is important that you analyze all aspects of your application and review the information concerning the product or system in the current product catalog. Due to the variety of operating conditions and applications for these products or systems, the user, through its own analysis and testing, is solely responsible for making the final selection of the products and systems and assuring that all performance, safety and warning requirements of the application are met.

The products described herein, including without limitation, product features, specifications, designs, availability and pricing, are subject to change by Parker Hannifin Corporation and its subsidiaries at any time without notice.

**Offer of Sale**

The items described in this document are hereby offered for sale by Parker Hannifin Corporation, its subsidiaries or its authorized distributors. This offer and its acceptance are governed by the provisions stated in the "Offer of Sale".

© Copyright 2020, Parker Hannifin Corporation, All Rights Reserved

Definitions..... 3

Introduction ..... 4

Troubleshooting Guide ..... 5

Troubleshooting Checklist ..... 6

Conversions ..... 7

Exploded Assembly View ..... 8

Disassembly & Inspection ..... 9–14

Assembly ..... 15–21

Offer of Sale ..... Inside Back Cover

**Definitions**

- NOTE:** A NOTE provides key information to make a procedure easier or quicker to complete.
- CAUTION:** A CAUTION refers to procedure that must be followed to avoid damaging the Transmission or other system components.
- WARNING:** A WARNING REFERS TO PROCEDURE THAT MUST BE FOLLOWED FOR THE SAFETY OF THE EQUIPMENT OPERATOR AND THE PERSON INSPECTING OR REPAIRING THE TRANSMISSION.

**Disclaimer**

This Service Manual has been prepared by Parker Hannifin for reference and use by mechanics who have been trained to repair and service hydraulic motors and systems on commercial and non-commercial equipment applications. Parker Hannifin has exercised reasonable care and diligence to present accurate, clear and complete information and instructions regarding the techniques and tools required for maintaining, repairing and servicing the complete line of Parker Integrated Hydrostatic Transmission Units. However, despite the care and effort taken in preparing this general Service Manual, Parker **makes no warranties** that (a) the Service Manual or any explanations, illustrations, information, techniques or tools described herein are either accurate, complete or correct as applied to a specific Transmission unit, or (b) any repairs or service of a particular Transmission unit will result in a properly functioning Transmission unit.

If inspection or testing reveals evidence of abnormal wear or damage to the unit or if you encounter circumstances not covered in the Manual, STOP – CONSULT THE EQUIPMENT MANUFACTURER’S SERVICE MANUAL AND WARRANTY. DO NOT TRY TO REPAIR OR SERVICE A UNIT WHICH HAS BEEN DAMAGED OR INCLUDES ANY PART THAT SHOWS EXCESSIVE WEAR UNLESS THE DAMAGED AND WORN PARTS ARE REPLACED WITH ORIGINAL PARKER REPLACEMENT AND SERVICE PARTS AND THE UNIT IS RESTORED TO PARKER SPECIFICATIONS FOR THE UNIT.

It is the responsibility of the mechanic performing the maintenance, repairs or service on a particular Transmission unit to (a) inspect the unit for abnormal wear and damage, (b) choose a repair procedure which will not endanger his/her safety, the safety of others, the equipment, or the safe operation of the Transmission, and (c) fully inspect and test the unit and the hydraulic system to insure that the repair or service of the unit has been properly performed and that the Transmission will function properly.



This service manual has one purpose: to guide you in maintaining, troubleshooting, and servicing the 3Z Motor Series.

Material in this manual is organized so you can work on the 3Z Motors and get results without wasting time or being confused. To get these results, you should read this entire manual before you begin any work on the 3Z motor.

This manual also contains troubleshooting information and checklist. If you must service the 3Z motor, the checklist will help you to determine where the problem may be.

The three-column format of the Disassembly, Inspection, and Assembly sections will make it easier for you to conduct major work on the 3Z motor.

Column 1 gives a brief key for each procedure.

Column 2 explains in detail the procedure you should follow. Column 3 illustrates this procedure with photographs. Read all material carefully and pay special attention to the notes, cautions, and warnings.

Service part list charts are also provided in this manual with the part names and exploded view item numbers cross referenced to Parker service part numbers.

As you gain experience in servicing the 3Z motor, you may find that some information in this manual could be clearer or more complete. If so, let us know about it. Do not try to second guess the manual. If you are stuck, contact us. Servicing the 3Z motor should be a safe and productive procedure, in order for the unit to deliver the reliable, long-life operation engineered into it.

Note: Before troubleshooting any system problem, check service literature published by the equipment and/or component manufacturers. Follow their instructions, if given, for checking any component other than the 3Z unit.

## Preparation

Make your troubleshooting easier by preparing as follows:

- work in a clean, well-lighted place;
- have proper tools and materials nearby;
- have an adequate supply of clean petroleum-based solvent.

**WARNING: SINCE SOLVENTS ARE FLAMMABLE, BE EXTREMELY CAREFUL WHEN USING ANY SOLVENT, EVEN A SMALL EXPLOSION OR FIRE COULD CAUSE INJURY OR DEATH.**

**WARNING: WEAR EYE PROTECTION AND BE SURE TO COMPLY WITH OSHA AND OTHER MAXIMUM AIR PRESSURE REQUIREMENTS.**

## Preliminary Checks

Hydraulic systems are often trouble-free. Hence, the problem an operator complains of could be caused by something other than the hydraulic components.

Thus, once you have determined that a problem exists, start with the easy-to-check items, such as:

- parts damaged from impact that were not properly repaired, or that should have been replaced; and
- improper replacement parts used in previous servicing
- mechanical linkage problems such as binding, broken, or loose parts or slipping belts

## Hydraulic Components

If you think the problem is caused by a hydraulic component, start by checking the easy-to-reach items.

Check all hoses and lines for cracks, hardening, or other signs of wear. Reroute any usable hoses that are kinked, severely bent, or that rest against hot engine parts. Look for leaks, especially at couplings and fittings. Replace any hoses or lines that don't meet system flow and pressure ratings.

Next, go to the reservoir and filter or filters. Check fluid level and look for air bubbles. Check the filter(s). A filter with a maximum 40 micron filtration is recommended for the 3Z system.

Visually check other components to see if they are loosely mounted, show signs of leaks, or other damage or wear.

Excessive heat in a hydraulic system can create problems that can easily be overlooked. Every system has its limitation for the maximum amount of temperature.

After the temperature is attained and passed, the following can occur:

- oil seal leaks
- loss of efficiency such as speed and torque
- pump loss of efficiency
- pump failure
- hoses become hard and brittle
- hose failure

A normal temperature range means an efficient hydraulic system. Consult the manuals published by equipment and/or component manufacturers for maximum allowable temperature and hydraulic tests that may be necessary to run on the performance of the hydraulic components. The 3Z is not recommended for hydraulic systems with maximum temperatures above 200°F (93.3°C).

**Troubleshooting Checklist****3ZG Series**

<b>Trouble</b>	<b>Cause</b>	<b>Remedy</b>
<b>Oil Leakage</b>	1. Hose fittings loose, worn or damaged.	Check & replace damaged fittings or "O" Rings. Torque to manufacturers specifications
	2. Oil seal rings (4) deteriorated by excess heat.	Replace oil seal rings by disassembling 3Z unit
	3. Special bolt (1, 1A, 1B or 1C) loose or its sealing area deteriorated by corrosion.	(a) Loosen then tighten single bolt to torque specification. (b) Replace bolt.
	4. Internal shaft seal (16) worn or damaged.	Replace seal. Disassembly of 3Z unit necessary.
<b>Significant loss of speed under load</b>	1. Lack of sufficient oil supply	(a) Check for faulty relief valve and adjust or replace as required. (b) Check for and repair worn pump. (c) Check for and use correct oil for temperature of operation.
	2. Excessive heat.	Locate excessive heat source (usually a restriction) in the system and correct the condition.
<b>Low mechanical efficiency or undue high pressure required to operate unit</b>	1. Line blockage	Locate blockage source and repair or replace.
	2. Internal interference	Disassemble 3Z unit, identify and remedy cause and repair, replacing parts as necessary
	3. Lack of pumping pressure	Check for and repair worn pump.
	4. Excessive binding or loading in system external to 3Z unit.	Locate source and eliminate cause

**CAUTION: If the hydraulic system fluid becomes overheated [in excess of 200°F (93.3°C)], seals in the system can shrink, harden or crack, thus losing their sealing ability.**

### CONVERSIONS

<b>INCHES</b>	<b>mm</b>	<b>INCHES</b>	<b>mm</b>
.020	.51	1.060	26.92
.021	.53	1.295	32.89
.029	.74	1.297	32.94
.030	.76	1.396	35.46
.111	2.81	1.398	35.51
.119	3.02	1.500	38.10
.152	3.86	1.620	41.15
.160	4.06	1.622	41.20
.296	7.52	1.983	50.37
.304	7.72	1.985	50.42
.460	11.68	2.000	50.80
.470	11.94	2.120	53.85
.500	12.70	2.122	53.90
.585	14.86	2.233	56.72
.595	15.11	2.235	56.77
.660	16.76	2.483	63.07
.675	17.15	2.485	63.12
.750	19.05	2.500	63.50
1.000	25.40	2.880	73.20
1.058	26.87		

3ZG Exploded View - Service Bulletin

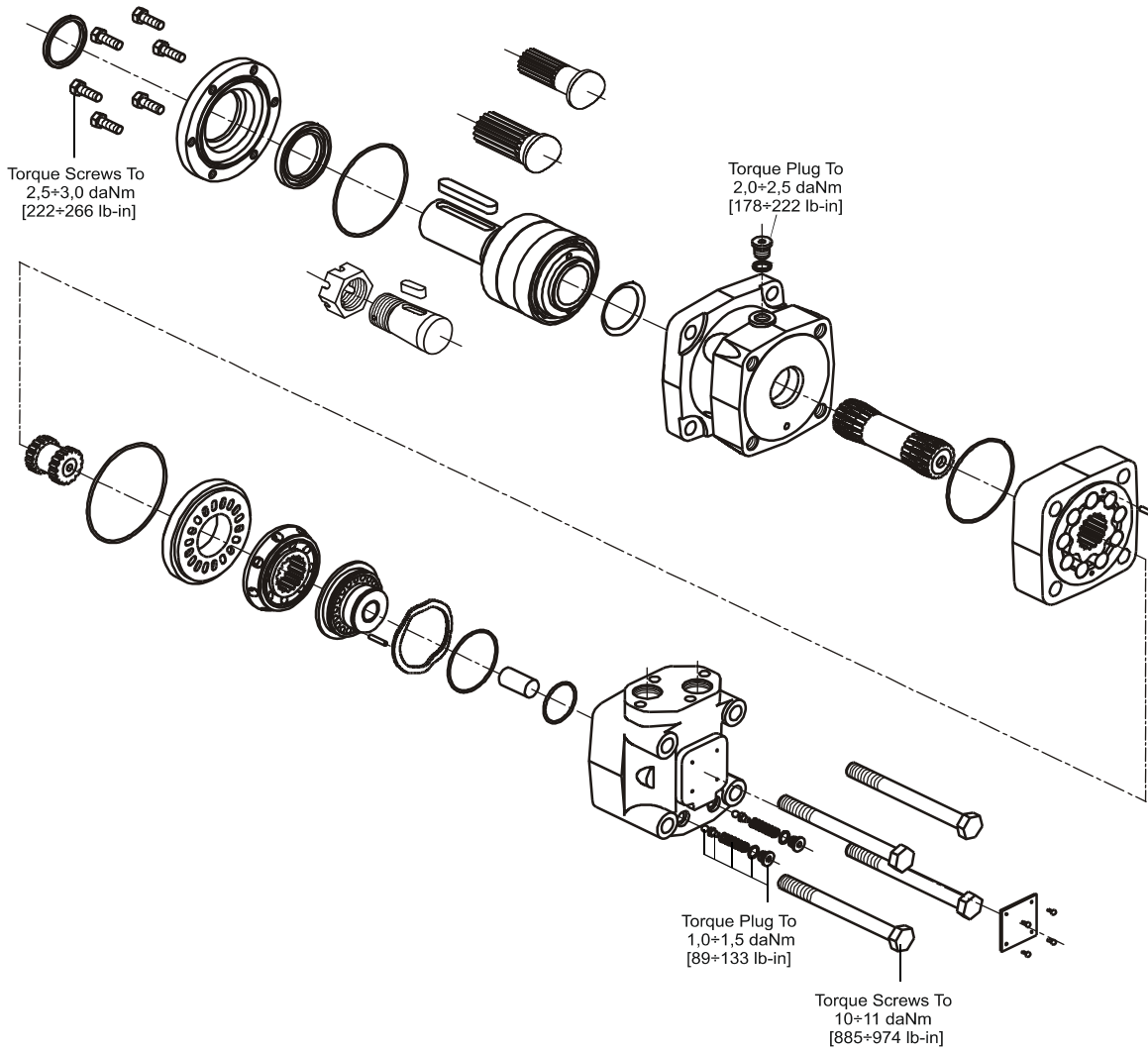

**Disassembly and Inspection**

---

**Preparation Before Disassembly**

- Before you disassemble the 3Z unit or any of its components read this entire manual. It provides important information on parts and procedures you will need to know to service the 3Z.
- Determine the type of end construction from the alternate views shown on the exploded view.
- Refer to “Tools and Materials Required for Services” section for tools and other items required to service the 3Z and have them available.
- Thoroughly clean off all outside dirt, especially from around fittings and hose connections, before disconnecting and removing the 3Z. Remove rust or corrosion from coupling shaft.
- Remove coupling shaft connections and hose fittings and immediately plug port holes and fluid lines.
- Remove the 3Z from system, drain it of fluid and take it to a clean work surface.
- Clean and dry the 3Z before you start to disassemble the unit.
- As you disassemble the 3Z clean all parts, except seals, in clean petroleum-based solvent, and blow them dry.

**WARNING:** petroleum-base solvents are flammable. Be extremely careful when using any solvent. Even a small explosion or fire could cause injury or death.

**WARNING:** WEAR EYE PROTECTION AND BE SURE TO COMPLY WITH OSHA OR OTHER MAXIMUM AIR PRESSURE REQUIREMENTS.

**CAUTION:** Never steam or high pressure wash hydraulic components. Do not force or abuse closely fitted parts.

- Keep parts separate to avoid nicks and burrs.
- Discard all seals and seal rings as they are removed from the 3Z. Replace all seals, seal rings and any damaged or worn parts with genuine Parker or OEM approved service parts.

**Disassembly and Inspection****Reference Exploded Assembly View**

**Place Motor in a Vise** Place the motor in a soft jawed vise, with coupling shaft pointed down and the vise jaws clamping firmly on the sides of the housing. (Figure 1)

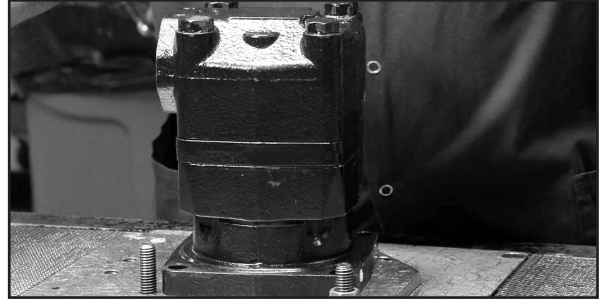

Figure 1

**Scribe Alignment Mark** Using a paint pen, place an alignment mark down and across the motor components from end cover to housing to facilitate reassembly orientation where required.

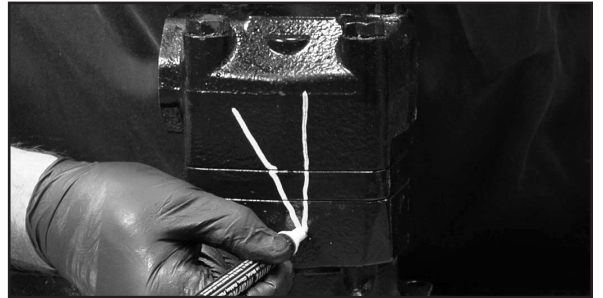

Figure 2

**WARNING** If the motor is not firmly held in the vise it could be dislodged during the service procedures, causing injury. (Figure 2)

**Remove Bolts** Using a torque wrench, remove four 7/8" bolts that hold the end cover onto motor. (Figure 3)

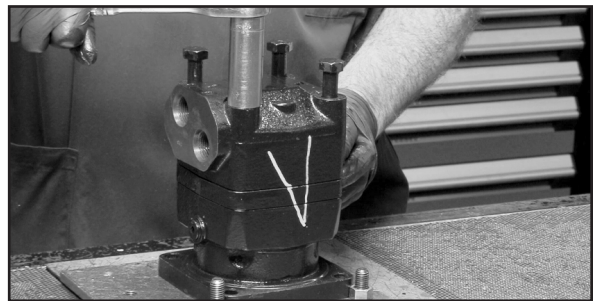

Figure 3

**Inspect Bolts** Inspect each bolt for damaged or stretched threads. (Figure 4)



Figure 4

**Remove End Cover** Remove end cover from motor and thoroughly wash the end cover in proper solvent and blow dry. Inspect end cover for any damage. (Figure 5)



Figure 5

**Disassembly and Inspection**

**NOTE** See diagram of end cover components. The next five disassembly steps will be directly related to removing components from within the end cover. (Figure 6)

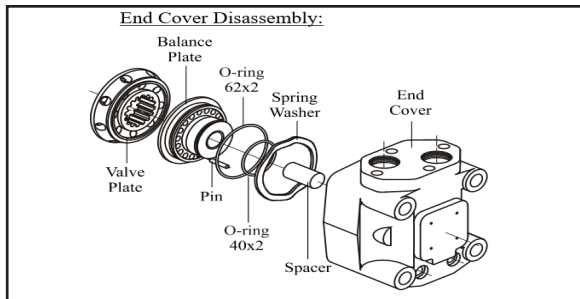

Figure 6

**Remove Roll Pin**

Remove roll pin from the end cover.

**NOTE** If the roll pin does not fall out as you remove the end cover, turn the end cover with the disc valve facing down onto a clean soft surface. Knock several times using plastic hammer on the rear end cover. Set aside fallen parts in order as shown above. (Figure 7)

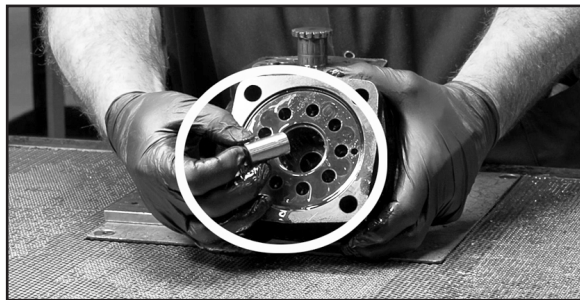

Figure 7

**Remove O-rings from Endcover**

Using a small screw driver, remove the O-ring from the endcover. (Figure 8)

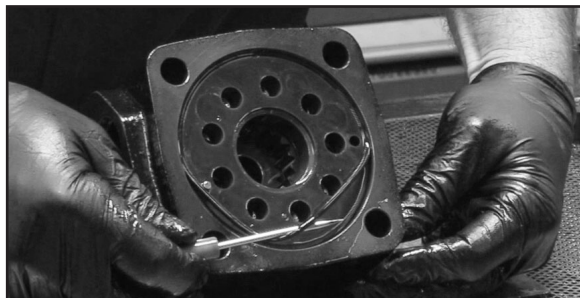

Figure 8

**Remove Disc Valve and Balance Plate**

Remove disc valve and inspect for any spline chipping or other damage. Insert your fingers into the middle of the end cover, lightly spinning as you lift the plates out of the end cover. (Figure 9)



Figure 9

**Remove the Valve and Timing Plates**

Separate the valve plate from the timing plate. (Figure 10)

**NOTE** Set end cover, disc valve, balance plate, and timing plate to the side. Return to the motor housing in the vice to continue with disassembly.



Figure 10

**Disassembly and Inspection****Add Alignment Marks to Rotor Spline & Drive Link**

Using a grease pen or etching ink, add a mark to the stator for reference on reassembly. (Figure 11)

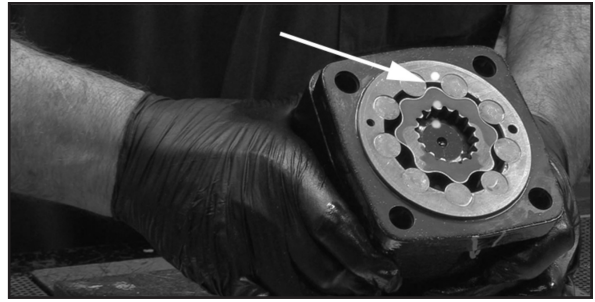

Figure 11

**Remove the Stator**

Remove the stator from the motor and set aside. (Rotor and roller vanes will remain loose on the motor). (Figure 12)

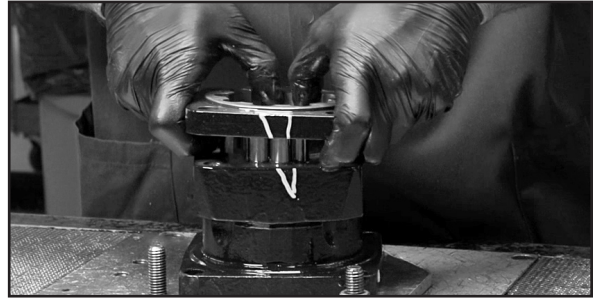

Figure 12

**Remove the Roller Vanes**

Roller vanes will likely slide out of the stator as you remove it from the motor. Make sure to place the roller vanes aside for reassembly later on (Figure 13)



Figure 13

**Remove O-ring from Stator**

Remove the O-ring from the groove in the stator. (Figure 14)

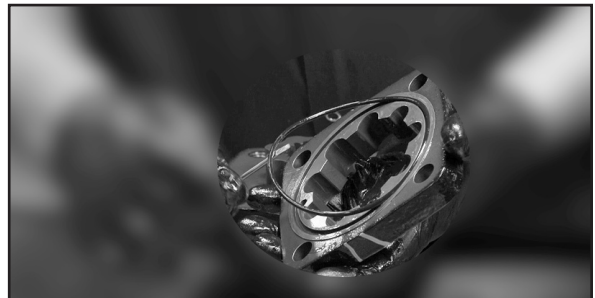

Figure 14

**Remove # 2 Drive Link**

Remove the shorter drive link from the disc valve. Inspect for chipping or other damage to the drive link (Figure 15)



Figure 15

**Disassembly and Inspection**

**Remove the Rotor**

Remove the rotor from the drive link. (Figure 16)



Figure 16

**Alignment Marks from Drive Link to Housing**

Using a grease pen, add alignment mark from the drive link to the housing. (Figure 17)



Figure 17

**Remove Drive Link**

Remove the drive link from the coupling shaft. Inspect for chipping and other visual damages. (Figure 18)



Figure 18

**NOTE**

Set Housing Aside so End Cover can be Disassembled.

**Rotate Motor**

Rotate the motor so the output shaft is facing up. (Figure 19)

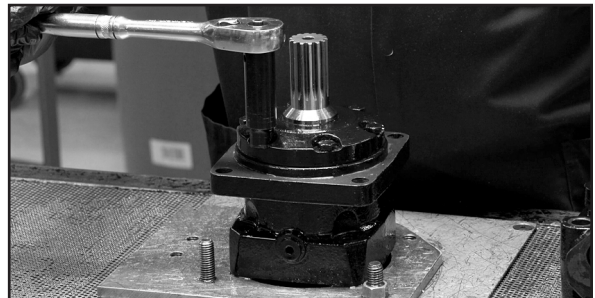

Figure 19

**Remove Output Shaft Bolts from Motor Housing**

With a wrench, remove the six bolts from the output shaft endcover.

**Inspect Bolts**

Inspect each bolt for damaged or stretched threads. (Figure 20)



Figure 20

**Disassembly and Inspection****Remove Output Shaft Cover**

Use a small screwdriver to pry off the output shaft endcover. (Figure 21)

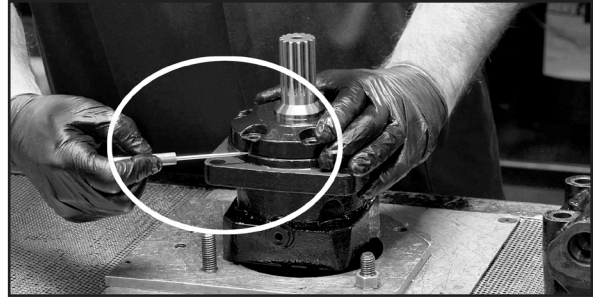

Figure 21

**Remove O-rings from Output Shaft Cover**

Remove the O-ring from the output shaft cover. This will be the larger O-ring. (Figure 22)



Figure 22

**Remove Shaft Seal**

Remove the shaft seal from the output shaft cover with an arbor press. If you do not have an arbor press, you can use a flathead screwdriver and rubber mallet to push out the seal (Figure 23)

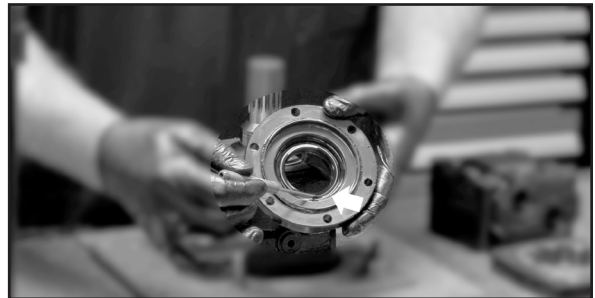

Figure 23

**Remove Dust Seal (D&W)**

Remove the dust seal (D&W) from the output shaft cover with an arbor press. If you do not have an arbor press, you can use a flathead screwdriver and rubber mallet to push out the seal. (Figure 24)



Figure 24

**NOTE**

Do not damage the separating flange. Make sure the tool is clearly below the cast flange that separates the dust seal and the shaft seal. (Figure 25)



Figure 25

**Disassembly Complete**

- Replace all seals and seal rings with new ones each time you reassemble the 3Z unit. Lubricate all seals and seal rings with SAE 10W40 oil or clean grease before assembly.
- **NOTE: Individual seals and seal rings as well as a complete seal kit are available. The parts should be available through most OEM parts distributors or Parker approved 3Z distributors. (Contact your local dealer for availability).**
- **NOTE: Unless otherwise indicated, do not oil or grease parts before assembly.**
- Wash all parts in clean petroleum-based solvents before assembly. Blow them dry with compressed air. Remove any paint chips from mating surfaces of the end cover, commutator set, manifold rotor set, wear plate and housing and from port and sealing areas.

**WARNING**

**WARNING: SINCE THEY ARE  
FLAMMABLE, BE EXTREMELY CAREFUL  
WHEN USING ANY SOLVENT. EVEN A  
SMALL EXPLOSION OR FIRE COULD  
CAUSE INJURY OR DEATH**

**WARNING**

**WARNING: WEAR EYE PROTECTION  
AND BE SURE TO COMPLY WITH OSHA  
OR OTHER MAXIMUM AIR PRESSURE  
REQUIREMENTS.**

**Begin reassembly**

Begin motor reassembly on a stable work surface or within a vice. Wipe all parts of the motor body down before reassembly to ensure all debris and paint chips are removed. (Figure 26)

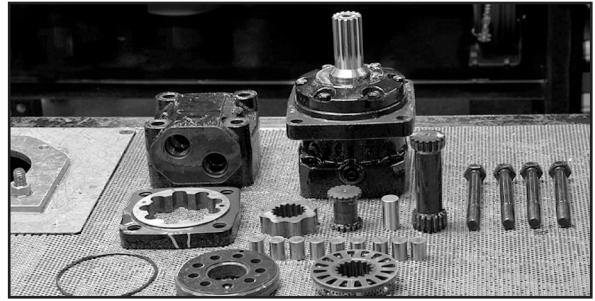

Figure 26

**WARNING**

If the motor is not firmly held stable or in the vise, it could tip over during the service procedures, causing injury.

**Install the Dust Seal (D&W)**

Place the dust seal onto the output shaft endcover. With a rubber mallet, lightly tap it in until it fits flush with the endcover. (Figure 27)

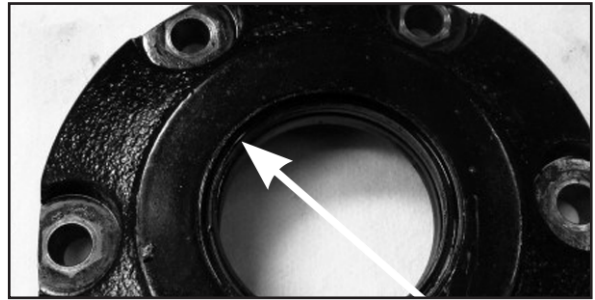

Figure 27

**Install Shaft Seal**

Using an arbor press, install the shaft seal to the output shaft cover. (Figure 28)

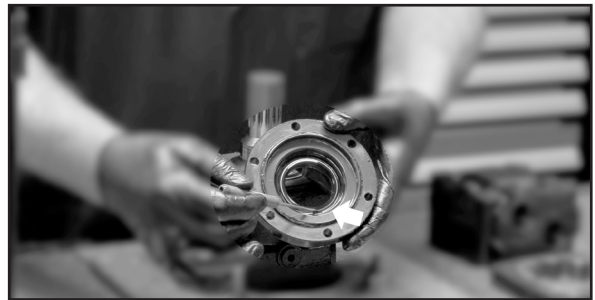

Figure 28

**Install Output Shaft Endcover O-rings**

Install the new O-ring into the output shaft cover. Press down with fingers to ensure the O-ring is fully seated. (Figure 29)



Figure 29

**Install Shaft End Cover**

With the output shaft facing you, install the shaft endcover. (Figure 30)

**CAUTION**

Be sure not to roll or pinch the O-rings as you place the output shaft endcover over the shaft itself.



Figure 30

**NOTE**

Grease all six bolts of the output shaft endcover with Loctite prior to wrenching/torquing them down. (Figure 31)



Figure 31

**Torque Bolts into Output Shaft Endcover**

Insert bolts into output shaft endcover and torque down to 222—266 lb-in. (Figure 32)



Figure 32

**NOTE**

Remember to tighten bolts down in star pattern. (Figure 33)

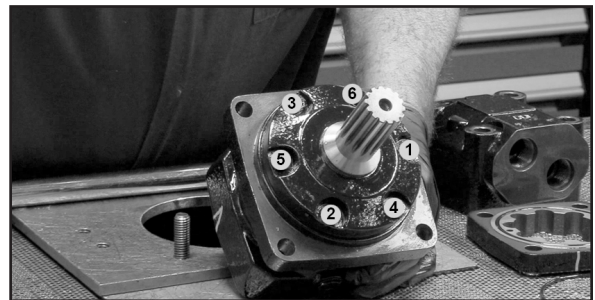

Figure 33

**Rotate Motor**

Flip motor over in vice so the output shaft is facing down. (Figure 34)

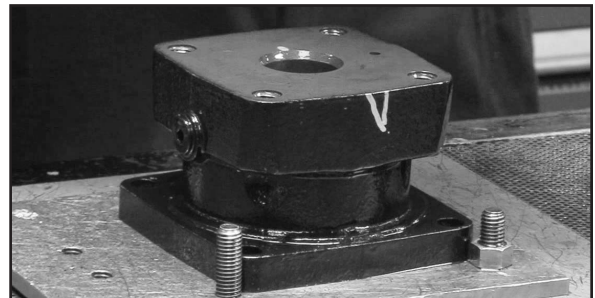

Figure 34

**Reinstall Drive Link**

Wipe surface clean of oil and debris. Then, install the drive link. (Figure 35)



Figure 35

**Line Up Alignment Marks**

Make sure the alignment marks on the housing face and the drive link are aligned. (Figure 36)

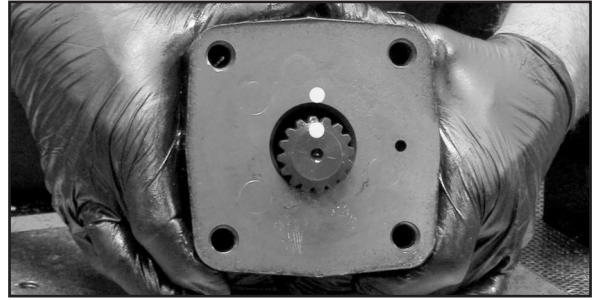

Figure 36

**Install Rotor**

Reinstall the rotor onto the drive link. Make sure the alignment mark on the rotor are aligned with the alignment mark on the drive link. (Figure 37)

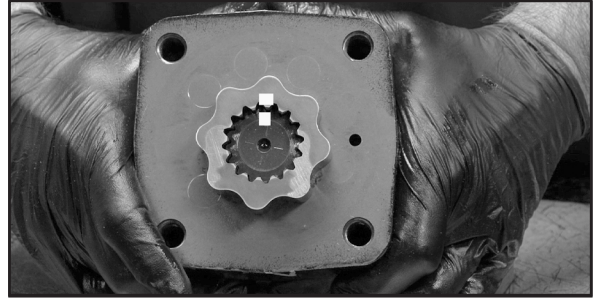

Figure 37

**Install Stator O-Rings**

Install the O-rings into the stator groove. (Figure 38)

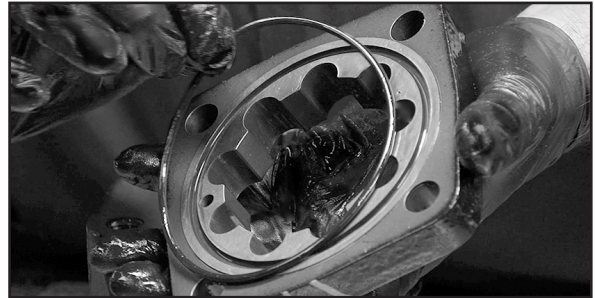

Figure 38

**Install Stator**

Install the stator onto the motor with the O-ring facing down. (Figure 39)

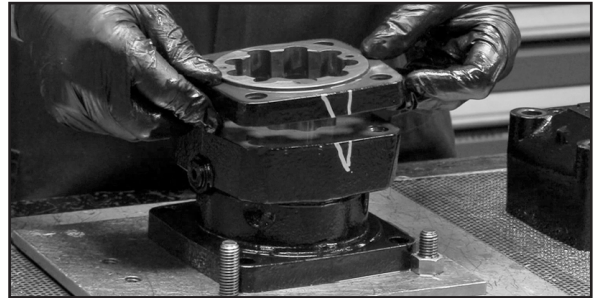

Figure 39

**NOTE**

Make sure the alignment marks on the outside of the motor line up in the correct direction.

**Install Rotor Vanes**

Replace all nine (9) roller vanes into the stator. (Figure 40)



Figure 40

**NOTE**

Timing Alignment diagram for Reference (Figure 41)

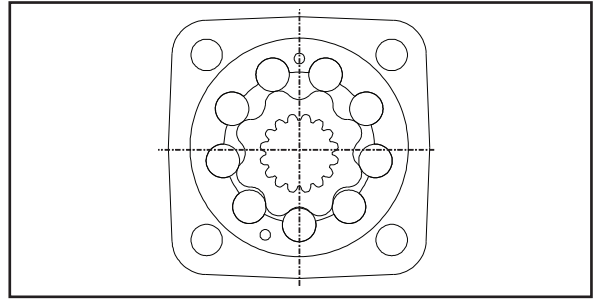

Figure 41

**Install #2 Drive Link**

Install the smaller drive link into the rotor set. (Figure 42)

Make sure to line up the guide pins with the pin holes in the motor body.

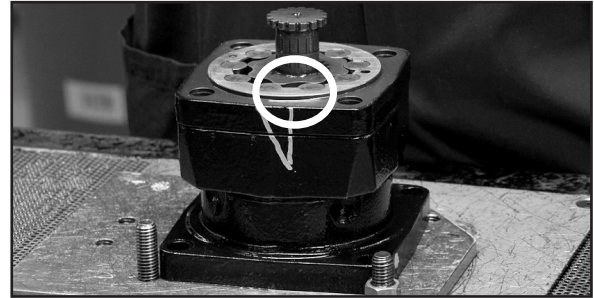

Figure 42

**Install Balance Plate**

Reinstall the balance plate onto the motor. (Figure 43)

**NOTE**

Make sure to line up the guide pins with the pin holes in the motor body.

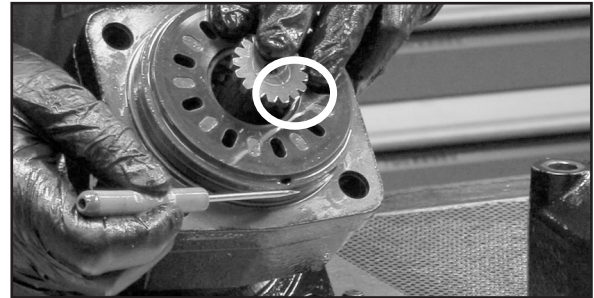

Figure 43

**Install Channel Plate**

Place the channel plate over top of the balance plate. (Figure 44)



Figure 44

**Standard Rotation Procedure**

Looking straight down at the manifold from above, align the alignment mark on the drive link with any one of the holes on the disc valve and set the disc valve down onto the drive link.

Rotate the drive link 15 degrees counter clockwise to achieve standard rotation. (Figure 45)

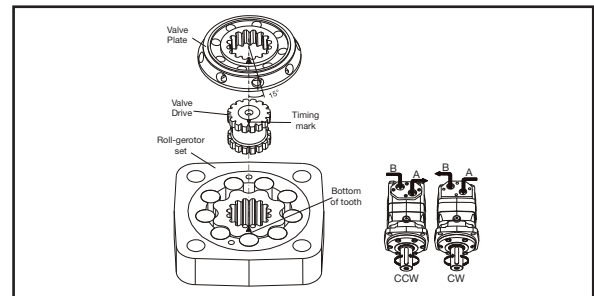

Figure 45

**Assembly**

**Reverse Timing Rotation Procedure**

Looking straight down at the manifold from above, align the alignment mark on the drive link with any one of the holes on the disc valve and set the disc valve down onto the drive link.

Rotate the drive link 15 degrees clockwise to achieve reverse rotation. (Figure 46)

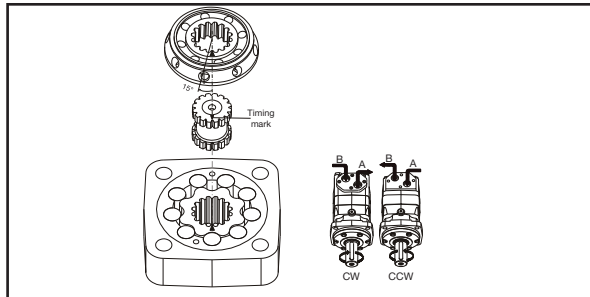

Figure 46

**Install O-ring into Balance Plate**

Replace the O-ring seal onto the bottom of the balance plate. (Figure 47)



Figure 47

**NOTE**

Use your fingers to fit the seal firmly into the balance plate groove. (Figure 48)



Figure 48

**Install Roll Pin**

Reinstall roll pin inside the end cover. Make sure the roll pin is flush with the end cover. (Figure 49)

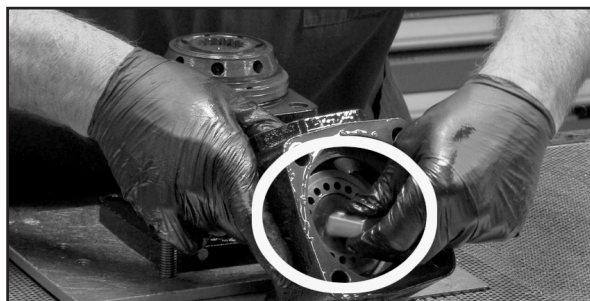

Figure 49

**Install End Cover onto Motor Body**

Install the end cover onto the motor body. (Figure 50)

**NOTE**

Verify alignment markings on the outside of the motor match.

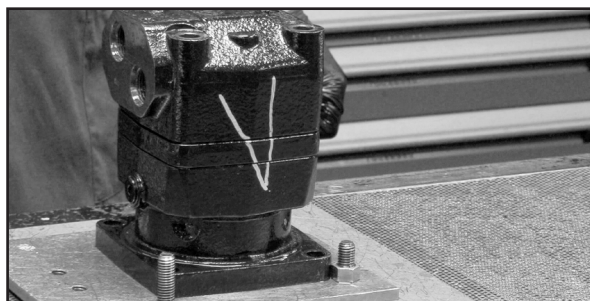

Figure 50

**Assembly****3ZG Series****Install Bolts**

Install the four (4) motor bolts.  
Do not grease these bolts  
before reinstalling. Hand tighten  
first in an X pattern. (Figure 51)

Torque bolts to 885 to 974 lb-in.



Figure 51

**End of Assembly**

(Figure 52)

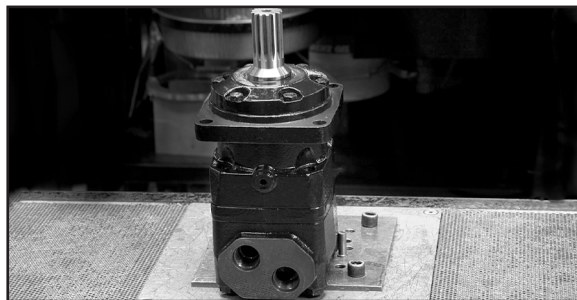

Figure 52



## 3Z Motor Service Procedure 3ZG Series

### Offer of Sale

The items described in this document and other documents and descriptions provided by Parker Hannifin Corporation, its subsidiaries and its authorized distributors ("Seller") are hereby offered for sale at prices to be established by Seller. This offer and its acceptance by any customer ("Buyer") shall be governed by all of the following Terms and Conditions. Buyer's order for any item described in its document, when communicated to Seller verbally, or in writing, shall constitute acceptance of this offer. All goods, services or work described will be referred to as "Products".

**1. Terms and Conditions.** Seller's willingness to offer Products, or accept an order for Products, to or from Buyer is subject to these Terms and Conditions or any newer version of the terms and conditions found on-line at [www.parker.com/saleterms/](http://www.parker.com/saleterms/). Seller objects to any contrary or additional terms or conditions of Buyer's order or any other document issued by Buyer.

**2. Price Adjustments; Payments.** Prices stated on Seller's quote or other documentation offered by Seller are valid for 30 days, and do not include any sales, use, or other taxes unless specifically stated. Unless otherwise specified by Seller, all prices are F.C.A. Seller's facility (INCOTERMS 2010). Payment is subject to credit approval and is due 30 days from the date of invoice or such other term as required by Seller's Credit Department, after which Buyer shall pay interest on any unpaid invoices at the rate of 1.5% per month or the maximum allowable rate under applicable law.

**3. Delivery Dates; Title and Risk; Shipment.** All delivery dates are approximate and Seller shall not be responsible for any damages resulting from any delay. Regardless of the manner of shipment, title to any products and risk of loss or damage shall pass to Buyer upon placement of the products with the shipment carrier at Seller's facility. Unless otherwise stated, Seller may exercise its judgment in choosing the carrier and means of delivery. No deferment of shipment at Buyers' request beyond the respective dates indicated will be made except on terms that will indemnify, defend and hold Seller harmless against all loss and additional expense. Buyer shall be responsible for any additional shipping charges incurred by Seller due to Buyer's acts or omissions.

**4. Warranty.** Seller warrants that the Products sold hereunder shall be free from defects in material or workmanship for a period of eighteen months from the date of delivery to Buyer or 2,000 hours of normal use, whichever occurs first. The prices charged for Seller's products are based upon the exclusive limited warranty stated above, and upon the following disclaimer: **DISCLAIMER OF WARRANTY: THIS WARRANTY COMPRISES THE SOLE AND ENTIRE WARRANTY PERTAINING TO PRODUCTS PROVIDED HEREUNDER. SELLER DISCLAIMS ALL OTHER WARRANTIES, EXPRESS AND IMPLIED, INCLUDING DESIGN, MERCHANTABILITY AND FITNESS FOR A PARTICULAR PURPOSE.**

**5. Claims; Commencement of Actions.** Buyer shall promptly inspect all Products upon delivery. No claims for shortages will be allowed unless reported to the Seller within 10 days of delivery. No other claims against Seller will be allowed unless asserted in writing within 30 days after delivery. Buyer shall notify Seller of any alleged breach of warranty within 30 days after the date the defect is or should have been discovered by Buyer. Any action based upon breach of this agreement or upon any other claim arising out of this sale (other than an action by Seller for an amount due on any invoice) must be commenced within 12 months from the date of the breach without regard to the date breach is discovered.

**6. LIMITATION OF LIABILITY.** UPON NOTIFICATION, SELLER WILL, AT ITS OPTION, REPAIR OR REPLACE A DEFECTIVE PRODUCT, OR REFUND THE PURCHASE PRICE. IN NO EVENT SHALL SELLER BE LIABLE TO BUYER FOR ANY SPECIAL, INDIRECT, INCIDENTAL OR CONSEQUENTIAL DAMAGES ARISING OUT OF, OR AS THE RESULT OF, THE SALE, DELIVERY, NON-DELIVERY, SERVICING, USE OR LOSS OF USE OF THE PRODUCTS OR ANY PART THEREOF, OR FOR ANY CHARGES OR EXPENSES OF ANY NATURE INCURRED WITHOUT SELLER'S WRITTEN CONSENT, EVEN IF SELLER HAS BEEN NEGLIGENT, WHETHER IN CONTRACT, TORT OR OTHER LEGAL THEORY. IN NO EVENT SHALL SELLER'S LIABILITY UNDER ANY CLAIM MADE BY BUYER EXCEED THE PURCHASE PRICE OF THE PRODUCTS.

**7. User Responsibility.** The user, through its own analysis and testing, is solely responsible for making the final selection of the system and Product and assuring that all performance, endurance, maintenance, safety and warning requirements of the application are met. The user must analyze all aspects of the application and follow applicable industry standards and Product information. If Seller provides Product or system options, the user is responsible for determining that such data and specifications are suitable and sufficient for all applications and reasonably foreseeable uses of the Products or systems.

**8. Loss to Buyer's Property.** Any designs, tools, patterns, materials, drawings, confidential information or equipment furnished by Buyer or any other items which become Buyer's property, will be considered obsolete and may be destroyed by Seller after two consecutive years have elapsed without Buyer ordering the items manufactured using such property. Seller shall not be responsible for any loss or damage to such property while it is in Seller's possession or control.

**9. Special Tooling.** A tooling charge may be imposed for any special tooling, including without limitation, dies, fixtures, molds and patterns, acquired to manufacture Products. Such special tooling shall be and remain Seller's property notwithstanding payment of any charges by Buyer. In no event will Buyer acquire any interest in apparatus belonging to Seller which is utilized in the manufacture of the Products, even if such apparatus has been specially converted or adapted for such manufacture and notwithstanding any charges paid by Buyer. Unless otherwise agreed, Seller shall have the right to alter, discard or otherwise dispose of any special tooling or other property in its sole discretion at any time.

**10. Buyer's Obligation; Rights of Seller.** To secure payment of all sums due or otherwise, Seller shall retain a security interest in the goods delivered and this agreement shall be deemed a Security Agreement under the Uniform Commercial Code. Buyer authorizes Seller as its attorney to execute and file on Buyer's behalf all documents Seller deems necessary to perfect its security interest.

**11. Improper use and Indemnity.** Buyer shall indemnify, defend, and hold Seller harmless from any claim, liability, damages, lawsuits, and costs (including attorney fees), whether for personal injury, property damage, patent, trademark or copyright infringement

or any other claim, brought by or incurred by Buyer, Buyer's employees, or any other person, arising out of: (a) improper selection, improper application or other misuse of Products purchased by Buyer from Seller; (b) any act or omission, negligent or otherwise, of Buyer; (c) Seller's use of patterns, plans, drawings, or specifications furnished by Buyer to manufacture Product; or (d) Buyer's failure to comply with these terms and conditions. Seller shall not indemnify Buyer under any circumstance except as otherwise provided.

**12. Cancellations and Changes.** Orders shall not be subject to cancellation or change by Buyer for any reason, except with Seller's written consent and upon terms that will indemnify, defend and hold Seller harmless against all direct, incidental and consequential loss or damage. Seller may change product features, specifications, designs and availability with notice to Buyer.

**13. Limitation on Assignment.** Buyer may not assign its rights or obligations under this agreement without the prior written consent of Seller.

**14. Force Majeure.** Seller does not assume the risk and shall not be liable for delay or failure to perform any of Seller's obligations by reason of circumstances beyond the reasonable control of Seller (hereinafter "Events of Force Majeure"). Events of Force Majeure shall include without limitation: accidents, strikes or labor disputes, acts of any government or government agency, acts of nature, delays or failures in delivery from carriers or suppliers, shortages of materials, or any other cause beyond Seller's reasonable control.

**15. Waiver and Severability.** Failure to enforce any provision of this agreement will not waive that provision nor will any such failure prejudice Seller's right to enforce that provision in the future. Invalidation of any provision of this agreement by legislation or other rule of law shall not invalidate any other provision herein. The remaining provisions of this agreement will remain in full force and effect.

**16. Termination.** Seller may terminate this agreement for any reason and at any time by giving Buyer thirty (30) days written notice of termination. Seller may immediately terminate this agreement, in writing, if Buyer: (a) commits a breach of any provision of this agreement (b) appoints a trustee, receiver or custodian for all or any part of Buyer's property (c) files a petition for relief in bankruptcy on its own behalf, or by a third party (d) makes an assignment for the benefit of creditors, or (e) dissolves or liquidates all or a majority of its assets.

**17. Governing Law.** This agreement and the sale and delivery of all Products hereunder shall be deemed to have taken place in and shall be governed and construed in accordance with the laws of the State of Ohio, as applicable to contracts executed and wholly performed therein and without regard to conflicts of laws principles. Buyer irrevocably agrees and consents to the exclusive jurisdiction and venue of the courts of Cuyahoga County, Ohio with respect to any dispute, controversy or claim arising out of or relating to this agreement.

**18. Indemnity for Infringement of Intellectual Property Rights.** Seller shall have no liability for infringement of any patents, trademarks, copyrights, trade dress, trade secrets or similar rights except as provided in this Section. Seller will defend and indemnify Buyer against allegations of infringement of U.S. patents, U.S. trademarks, copyrights, trade dress and trade secrets ("Intellectual Property Rights"). Seller will defend at its expense and will pay the cost of any settlement or damages awarded in an action brought against Buyer based on an allegation that a Product sold pursuant to this Agreement infringes the Intellectual Property Rights of a third party. Seller's obligation to defend and indemnify Buyer is contingent on Buyer notifying Seller within ten (10) days after Buyer becomes aware of such allegations of infringement, and Seller having sole control over the defense of any allegations or actions including all negotiations for settlement or compromise. If a Product is subject to a claim that it infringes the Intellectual Property Rights of a third party, Seller may, at its sole expense and option, procure for Buyer the right to continue using the Product, replace or modify the Product so as to make it noninfringing, or offer to accept return of the Product and return the purchase price less a reasonable allowance for depreciation. Notwithstanding the foregoing, Seller shall have no liability for claims of infringement based on information provided by Buyer, or directed to Products delivered hereunder for which the designs are specified in whole or part by Buyer, or infringements resulting from the modification, combination or use in a system of any Product sold hereunder. The foregoing provisions of this Section shall constitute Seller's sole and exclusive liability and Buyer's sole and exclusive remedy for infringement of Intellectual Property Rights.

**19. Entire Agreement.** This agreement contains the entire agreement between the Buyer and Seller and constitutes the final, complete and exclusive expression of the terms of sale. All prior or contemporaneous written or oral agreements or negotiations with respect to the subject matter are herein merged.

**20. Compliance with Law, U.K. Bribery Act and U.S. Foreign Corrupt Practices Act.** Buyer agrees to comply with all applicable laws and regulations, including both those of the United Kingdom and the United States of America, and of the country or countries of the Territory in which Buyer may operate, including without limitation the U. K. Bribery Act, the U.S. Foreign Corrupt Practices Act ("FCPA") and the U.S. Anti-Kickback Act (the "Anti-Kickback Act"), and agrees to indemnify and hold harmless Seller from the consequences of any violation of such provisions by Buyer, its employees or agents. Buyer acknowledges that they are familiar with the provisions of the U. K. Bribery Act, the FCPA and the Anti-Kickback Act, and certifies that Buyer will adhere to the requirements thereof. In particular, Buyer represents and agrees that Buyer shall not make any payment or give anything of value, directly or indirectly to any governmental official, any foreign political party or official thereof, any candidate for foreign political office, or any commercial entity or person, for the purpose of influencing such person to purchase products or otherwise benefit the business of Seller.

2/12





Parker Hannifin Corporation  
**Pump & Motor Division**  
2745 Snapps Ferry Road  
Greeneville, TN 37745 USA  
phone: 423-639-8151  
fax: 423-787-2418  
[www.parker.com/pumpmotor](http://www.parker.com/pumpmotor)