

SBW110 Training

Next generation Steering Systems

- SBW110 Safety Description

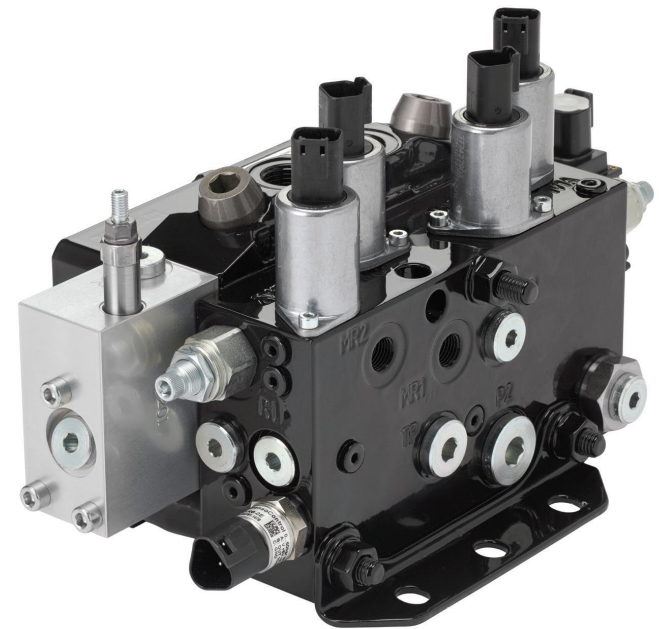

ENGINEERING YOUR SUCCESS.

SBW110 Safety, Short Description

Main function: - Flow from workport

Safety Functions: - Maintained steering
- No unintended steering

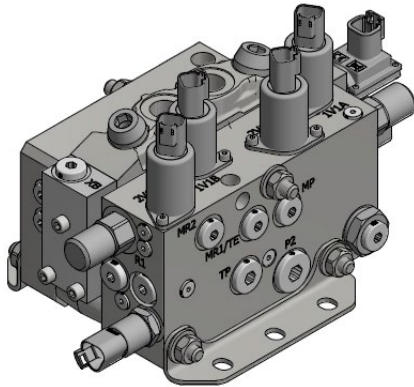

Why:

- Can be used with both safety functions:
“Maintained steering” and “No unintended steering”
- In many cases allows machine speed >20 km/h

OEM requirements:

- ISO 13849 category 3 / 4
- Up to PL d
- Up to PL e (extra pressure sensor required)

SBW110 Safety Description

- The SBW110 can be used in systems requiring a level of risk reduction depending on the complete steering system layout. It is the OEM responsibility to fulfill the performance level for the complete Steer-by-Wire system where the SBW110 is a component.
- SBW110 could be equipped with sensors used for diagnostic, failure detection shall be made in OEM control system.
- SBW110 can be used in systems requiring ISO 13849-1:2015 PLr a to e. Required performance level (PLr) for the steering is defined in the relevant C standard for the application or can be decided by the OEM.
- The SBW110 is designed according to ISO 13849-1:2015 and ISO 13849-2:2012 with design architecture category 3 (single fault tolerant), and the requirements in ISO 5010:2019 for rubber tired machines that has a maximum speed > 20 km/h.
- The valve **main function** (performance) is defined as **flow to workport**.
- The SBW110 is designed with **two safety functions** in mind:
 - **No unintended steering**, flow out from workport is not more than stated maximum leakage when there is no actuation current to the valve.
 - **Maintained steering**, in case of single failure the valve will maintain >70% flow out from workport.
- When fulfilling the requirements in instruction handbook H318000, the SBW110 is claimed to be single fault tolerant as a component in an OEM Steer-by-Wire system

SBW110 Reliability Data

Customer has to define which performance level they require and how many steering cycles per year. Then look if SBW110 MTTFd value is ok for the required performance level:

Reliability Data for SBW110	
Category	3
Diagnostic Coverage (DC) *	99%
MTTF_D	
$n_{op} \geq 1\,000\,000$	50
$1\,000\,000 > n_{op} \geq 500\,000$	75
$500\,000 > n_{op} \geq 250\,000$	100
$250\,000 > n_{op}$	120

Number of actuations per year gives the MTTFd value for SBW110.

* Diagnostic coverage (DC) value is met if diagnostic function 1 and 2 (DF1 & DF2) is implemented according to SBW110 Instruction Handbook

Picture from ISO13849-1.

Shows the achieved performance level depending on category, MTTFd and DC.

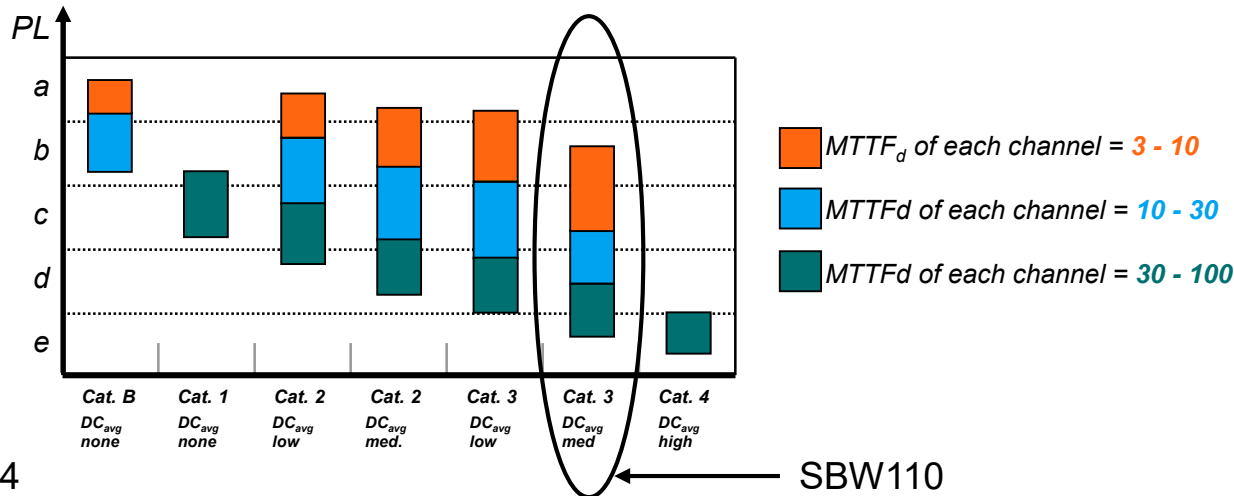

Denotation (DC avg)	Range
None	DC < 60%
Low	60% ≤ DC < 90%
Medium	90% ≤ DC < 99%
High	99% ≤ DC