

PowerTilt Series Service and Repair Manual



Table of Contents

Introduction

Table of Contents.....	2
Product Overview.....	3
Operation Technology.....	5
General Safety Guidelines.....	6
Product Identification.....	7

Installation and Maintenance

Installation and Mounting.....	8
Hydraulic Requirements and Plumbing.....	10
Maintenance.....	13
Adjusting Endplay.....	14
Troubleshooting Guide.....	17

Tools

Tools Required.....	18
---------------------	----

Drawings

Assembly Drawings.....	19
Piston Drawings.....	23
Exploded View.....	24
Parts List.....	25

Disassembly

Component Identification.....	34
Product Inspection.....	35
Standard Pin-on Coupler Removal.....	35
End Cap, Lock Ring and Cross Port Relief Valve Removal.....	37
Shaft Removal.....	38
Piston Sleeve Assembly Removal.....	39
Seal and Bearing Removal.....	40
Component and Timing Mark Inspection.....	41

Assembly

Dry Assembly.....	42
Seal and Bearing Installation.....	42
Piston Sleeve Installation.....	46
Shaft Installation.....	47
End Cap and Lock Ring Installation.....	48
Cross Port Relief Valve Installation.....	49
Standard Pin-on Coupler Installation.....	50

Post Assembly

Testing and Greasing.....	54
---------------------------	----

Offer of Sale

Offer of Sale.....	56
--------------------	----

Product Overview

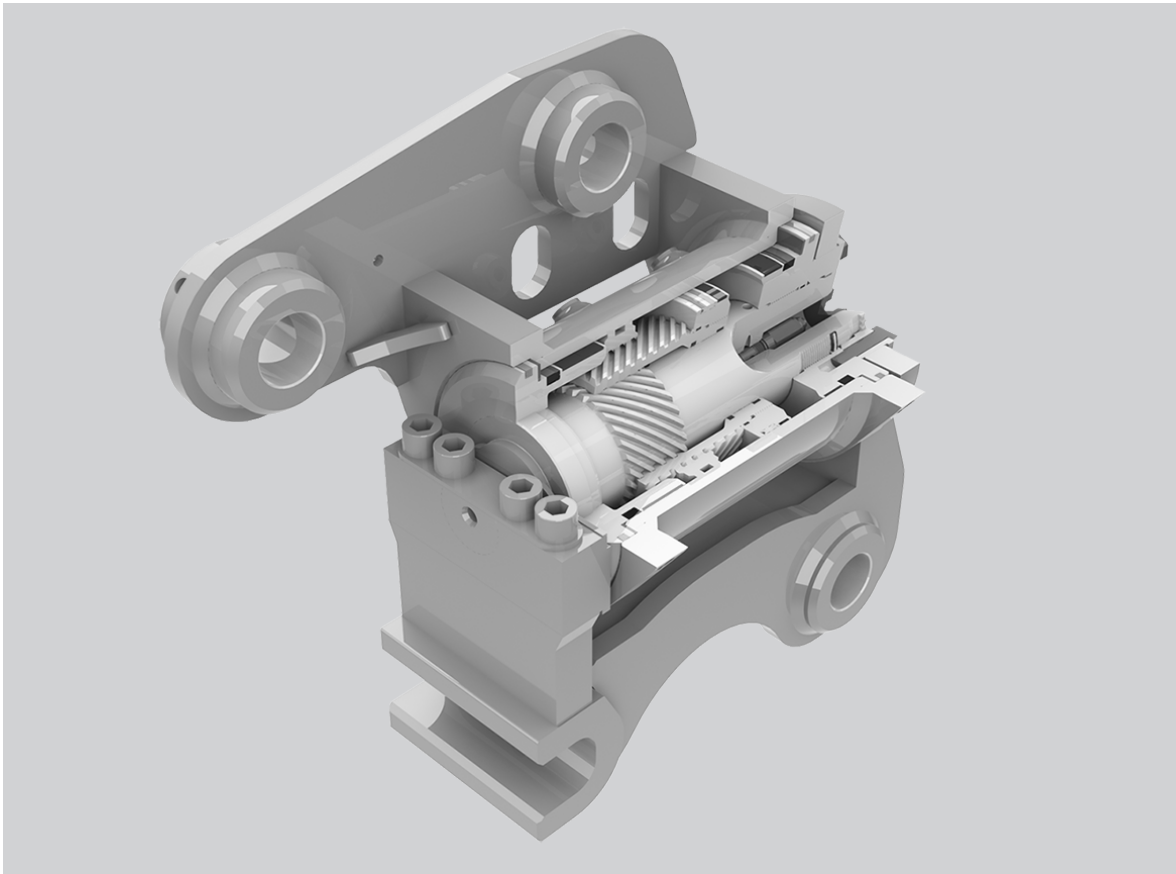

Product Introduction

Content in this Instruction, Service and Repair Manual applies to all current product models unless noted otherwise. For information on maintaining, servicing or repairing earlier product models

(TT, TTB and TBB series) please contact your local dealer or Parker's Service Department at 1-800-797-8458 (US and Canada) or email at CAD.mobile@support.parker.com.

Helac PowerTilt®, a construction equipment attachment from Parker Hannifin, can increase the productivity, profitability and versatility of backhoes or excavators by simply tilting the attachment instead of moving the entire machine.

PowerTilt is ideal for performing everyday tasks, or completing jobs that haven't been tried. Thousands of contractors worldwide have come to rely on PowerTilt since 1990 for cleaning ditches, clearing land, digging beveled trenches, spreading rip-rap, and positioning brushcutters, mowers and hydraulic hammers.

When used in combination with Helac PowerGrip®, a multi-purpose bucket, companies can achieve unmatched, hand-like manipulation and dexterity, dramatically maximizing productivity.

Product Overview

Basic Configurations



PT Series

Standard housing with welded-on ears. Lower end can be welded directly to a quick coupler or bucket.

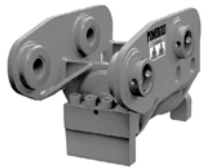

PTA/PTB Series

The housing and shaft are designed for customization. Ideal for integrating quick couplers at both the top and bottom. PTA Series housing is designed for welding; PTB Series housing incorporates drilled and tapped holes for bolt-mounting.



Custom Designs

Depending on the order quantity, custom-engineered configurations can be provided.

Specifications for PT, PTA and PTB Series

Model Size		6	7	8	9	10	11	12
Maximum Machine Weight	lb (kg)	10,500 (4,775)	15,000 (6,800)	20,000 (9,100)	28,700 (13,000)	45,000 (20,000)	60,000 (27,000)	75,000 (34,000)
Approximate PowerTilt Weight*	lb (kg)	180 (85)	320 (145)	425 (195)	575 (260)	850 (385)	1,200 (545)	1,500 (680)
Total Tilt		180°**	180°	180°	134°	134°	134°	134°
Output Torque	in-lbs (Nm)	25,000 (2,820)	42,000 (4,740)	63,000 (7,110)	94,000 (10,620)	130,000 (14,690)	165,000 (18,640)	220,000 (24,860)
Holding Torque	in-lbs (Nm)	50,000 (5,640)	84,000 (9,480)	126,000 (14,220)	188,000 (21,240)	260,000 (29,380)	330,000 (37,280)	440,000 (49,720)

* Weights may vary depending on model size. Approximate weights for PTA and PTB Series do not include mounting brackets or couplers.

** Actual rotation may vary slightly.

Operation Technology

PowerTilt uses Helac innovative, sliding-spline operating technology to convert linear piston motion into powerful shaft rotation. Each actuator is composed of a housing and two moving parts — the central shaft and piston.

Helical spline teeth on the shaft engage matching teeth on the piston's inside diameter. A second set of splines on the piston's outside diameter mesh with the gear in the housing.

Starting position

The piston is completely bottomed out. Bars indicate starting positions of piston and shaft. Arrows indicate directions they will rotate. The housing with integral ring gear remains stationary.

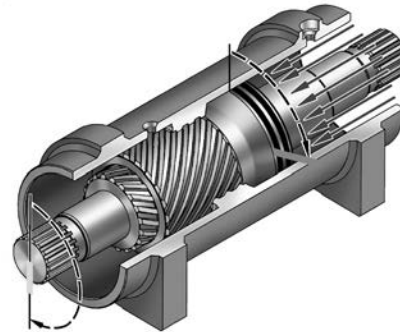
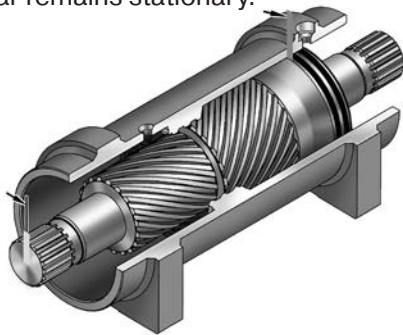

Ending position

When hydraulic pressure is applied to the piston, it moves axially, while the helical gearing causes the piston and shaft to rotate simultaneously. Applying pressure to the opposite port will return the piston and shaft to their original starting positions.

General Safety Guidelines

Cautionary Notices

Before beginning disassembly of the PowerTilt, there are several cautionary notices that should be considered. If you are not comfortable with repair or maintenance of this product, contact your local dealer or Parker Hannifin Corporation's Service Department for assistance.



⚠ WARNING
To avoid personal injury and machinery damage:
Read the Service and Repair Manual for proper installation, maintenance and repair procedures.



⚠ WARNING
Pinch point hazard:
Moving parts can cause serious injury.
Keep hands clear during operation.



⚠ WARNING
To avoid personal injury and machinery damage:
Make sure PowerTilt and/or attachment does not come in contact with boom, boom cylinder and/or operator area, particularly in fully curled position.



⚠ WARNING
To avoid personal injury and machinery damage:
Make sure no personnel are standing within the arc described by the movement of the attachment. PowerTilt increases the swing radius of buckets and tools.



⚠ CAUTION
To avoid personal injury and machinery damage:
Do not use PowerTilt or quick coupler for lifting or craning materials. PowerTilt should only be used to perform tasks for which it was designed.



NOTICE
To avoid damage to seals or other internal components:
Do not weld directly onto PowerTilt when it is fully assembled. Modifications may void product warranty.

Other Safety Guidelines and Precautions

1. PowerTilt should only be used to perform tasks for which it was designed. Abusing the product and/or using it for purposes for which it was not intended can expose the operator and others to hazards as well as result in damage to the PowerTilt, carrier and/or other attachments.
2. Modification to the PowerTilt is done at the owner's risk and may void the Helac Corporation, Attachments Division warranty.
3. PowerTilt is designed for a maximum bucket width as noted below. Applying the full force of the excavator or backhoe to the corner of a wide bucket (e.g. corner digging with a wide bucket) may cause premature wear and/or reduced equipment life. It is also recommended that the bucket widths are not exceeded.

Maximum Recommended Bucket Width for Use with PowerTilt

PowerTilt Model	Maximum Bucket Width
PT-6	47" (1,200 mm)
PT-7	55" (1,400 mm)
PT-8	59" (1,500 mm)
PT-9	66" (1,700 mm)
PT-10	70" (1,800 mm)
PT-11	82" (2,100 mm)
PT-12	94" (2,400 mm)

4. A decrease in breakout force may be experienced due to the increased tip radius and the added weight of the PowerTilt to the stick.
5. It is the owner's responsibility to be sure all safety equipment is in place and operating properly at all times. If safety decals fade, are damaged or become unreadable from a distance of 10 feet, they should be replaced immediately.

General Safety Guidelines

Be sure to post the warning decal provided by Parker Hannifin to the cab of the carrier machine.

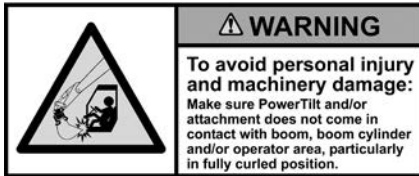

- PowerTilt should be used in conjunction with attachments that do not adversely affect the stability of the machine.

Important Notice

Parker Hannifin Corporation does not assume any responsibility beyond the design and performance of its construction equipment attachment products. The customer is solely responsible for engineering of mating structures, fasteners, and other associated components related to the installation of the product and its ultimate application.

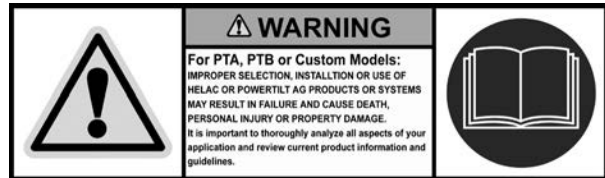

Product Identification

PowerTilt Identification

A unique serial number is located on each PowerTilt. This serial number is stamped on the housing and is also located on an Identification (ID) Tag. The serial number is located near the hydraulic ports, and may be required before parts and/or service issues can be resolved. It may be necessary to remove paint to expose the serial number.



Installation and Mounting

Each PowerTilt is engineered for a specific backhoe or excavator and is designed to be pin mounted directly to the machine. When using the Standard Pin-on Coupler, two sets of pins are required: one set to mount the PowerTilt to the dipper stick and a second set to mount the bucket or attachment to the PowerTilt. When using Universal or Hydraulic Quick Couplers, contact the respective coupler manufacturer for instructions and maintenance.

PT Series — Installing the PowerTilt onto the Carrier

All PowerTilt models should be mounted to the carrier according to the instructions outlined below.

1. Position the PowerTilt close to the carrier boom to ensure easy use of the lifting reach and range of the carrier boom.
2. Lower the dipper to approximately 2-3 inches (50-75 mm) above the PowerTilt. Roll out the bucket cylinder to lower the link bars to the PowerTilt.
3. Align the PowerTilt and link bar holes and install the link pin.
4. Slowly lift the PowerTilt to a safe height with the bucket and boom cylinders.
5. Curl the bucket cylinder until the PowerTilt and dipper holes align and install the bucket pivot pin. Rotate the pins as necessary and install the required retainers.

NOTICE

Do not attach a bucket or attachment to the PowerTilt until the hydraulic tool circuit for the PowerTilt is installed and operating correctly.

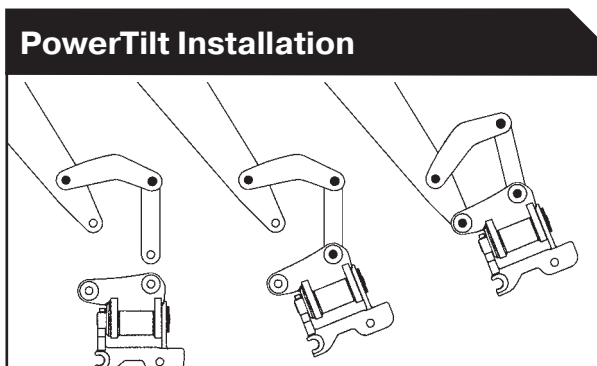

Installation and Mounting

PT Series — Mounting a Bucket or Attachment to the PowerTilt

To mount a bucket or an attachment to the PowerTilt with the Standard Pin-on Coupler, follow the steps listed below.

1. Install the hook pin in the bucket or attachment and position the bucket or attachment so the pin can be easily reached with the PowerTilt hook as shown in the below image.
2. Hook the bucket pin, being sure the hook is properly aligned to avoid damaging the hook.
3. Lift the bucket off the ground, then extend the bucket cylinder to pivot the PowerTilt until the second hole of the bucket or attachment aligns with the PowerTilt coupler pin hole.
4. Install the second pin and retain properly.
5. After mounting the bucket for the first time, the jacking bolt(s) on the back side of the hook require adjustment. Loosen the jam nut and thread the bolt until it touches the pin, then tighten the jam nut to lock the bolt in place. Proper adjustment will make it easier to align the mounting pins when changing buckets.

Attachment Mounting

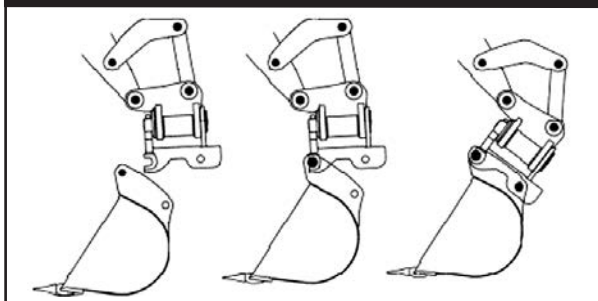

PT Series — Removing a Bucket or Attachment from the PowerTilt

To remove a bucket or an attachment from the PowerTilt with the Standard Pin-on Coupler, follow the steps listed below.

1. Position the bucket or attachment so it is lightly supported by the ground and in a position so it will not move or fall when a pin is removed. Remove the coupler pin (the pin furthest from the cab).
2. Gently place the bucket or attachment on the ground and move the PowerTilt away from the bucket or attachment to disengage completely. Use the bucket cylinder if necessary to make disengagement easier. Be careful not to damage the PowerTilt hook while removing the bucket or attachment.

Attachment Removal

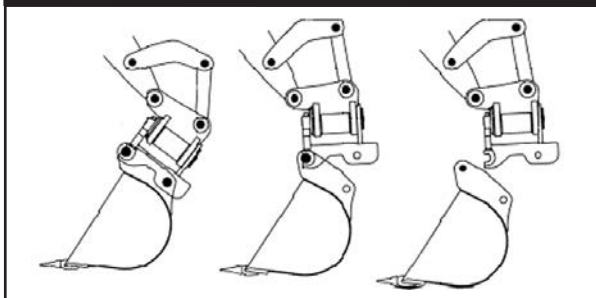

Hydraulic Requirements and Plumbing

Hydraulic Requirements

The Typical PowerTilt Circuit Chart (shown on this page) and the Tool Circuit Requirements Table (shown on the following page) illustrate the control circuit requirements for the PowerTilt. The hydraulic pressures and flow requirements must be observed or damage to the actuator can occur.

The installer of the PowerTilt is responsible for selecting the control circuits that are compatible with the excavator and meet the tool circuit requirements. Helac can be contacted for additional control circuits and methods for controlling the PowerTilt.

NOTICE

Most PowerTilts manufactured after 1997 incorporate an integral cross port relief valve mounted inside the shaft. If this secondary relief does not exist, then the circuit pressure must be lowered to match the cross port relief valve pressure.

Each PowerTilt model is manufactured with two ports, P1 and P2. This is done to assist in the hose routing. Refer to the Suggested Hose Routings Diagram on Page 12 for the recommended routings.

NOTICE

The majority of PowerTilts delivered to customers in North America incorporate SAE type ports. Customers outside of North America typically have BSPP type ports.

Typical PowerTilt Circuit

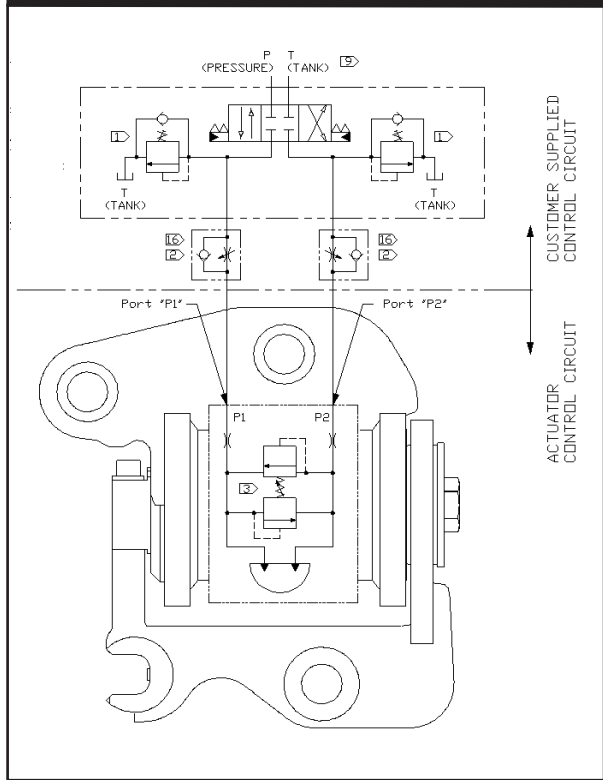

Tool Circuit Requirements for PT, PTA, PTB Series

Model Sizes		6	7	8	9	10	11	12
Displacement	in ³	32	62	89	118	159	215	277
	(cm ³)	(525)	(1060)	(1460)	(1935)	(2600)	(3515)	(4540)
Suggested Oil Flow***	gpm	1.3-4	3-9	4-12	5-15	7-21	9-27	12-36
	(l/min)	(5-16)	(11-32)	(15-44)	(19-58)	(26-78)	(35-105)	(45-136)
Port Connections*	SAE	4	4	6	6	6	6	6
	BSPP	(1/4)	(1/4)	(1/4)	(1/4)	(1/4)	(1/4)	(3/8)
Hydraulic Hose and Tube Sizing								
Hose, Tube (Optional)	in	3/8	3/8	3/8	1/2	1/2	5/8	5/8
	(mm)	(10)	(10)	(10)	(12)	(12)	(16)	(16)
Min. Whip Hose	in	1/4	1/4	1/4	3/8	3/8	3/8	3/8
	(mm)	(6)	(6)	(6)	(10)	(10)	(10)	(10)
Hydraulic Pressures								
Cross Port Relief Valve Pressure**		3,050-3,450 psi (220-230 bar)						
Circuit Pressure		2,900-3,000 psi (200-207 bar)						
Maximum Circuit Back Pressure		580 psi (40 bar)						

* Most PowerTilt models are manufactured with four ports: two ports (P1) and two ports (P2). The majority of all PowerTilts delivered to North American customers incorporate SAE port connections. PowerTilts delivered to customers outside of North America incorporate BSPP port connections.

** PowerTilts are equipped with factory-installed integral cross port relief valves.

***Suggested oil flows will yield a speed of 6 seconds at the low end and 2 seconds at the high end, stop to stop.

Hydraulic Requirements and Plumbing

Plumbing

Hose and tube size recommendations can be found in the Tool Circuit Requirements Chart shown below.

The position of the hoses is important for reliable operation. Refer to the Suggested Hose Routings Chart on Page 12 for suggested hose routings.

Hoses should be routed between the housing brackets and not through the openings in the brackets adjacent to the ports which are used for the manufacturing process. Depending on the geometry of the installation, it may be advisable to cover the hoses with protective sheathing.

Connect hydraulic hoses to the appropriate ports using fittings as shown on Pages 16 through 20. Be sure the hoses do not cross, foul, crush or chafe when operating the PowerTilt or machine.

Verify proper hose routing for all possible positions of the PowerTilt and all attachments, which are to be used with the PowerTilt. Repair any oil leaks immediately.

NOTICE

When installing a new tool circuit or hydraulic lines, flush all the tool circuit lines with hydraulic oil prior to connecting the PowerTilt. This will remove any contaminants from the circuit components which may have accumulated during manufacturing and/or installation.

Hydraulic Requirements and Plumbing

Suggested Hose Routings

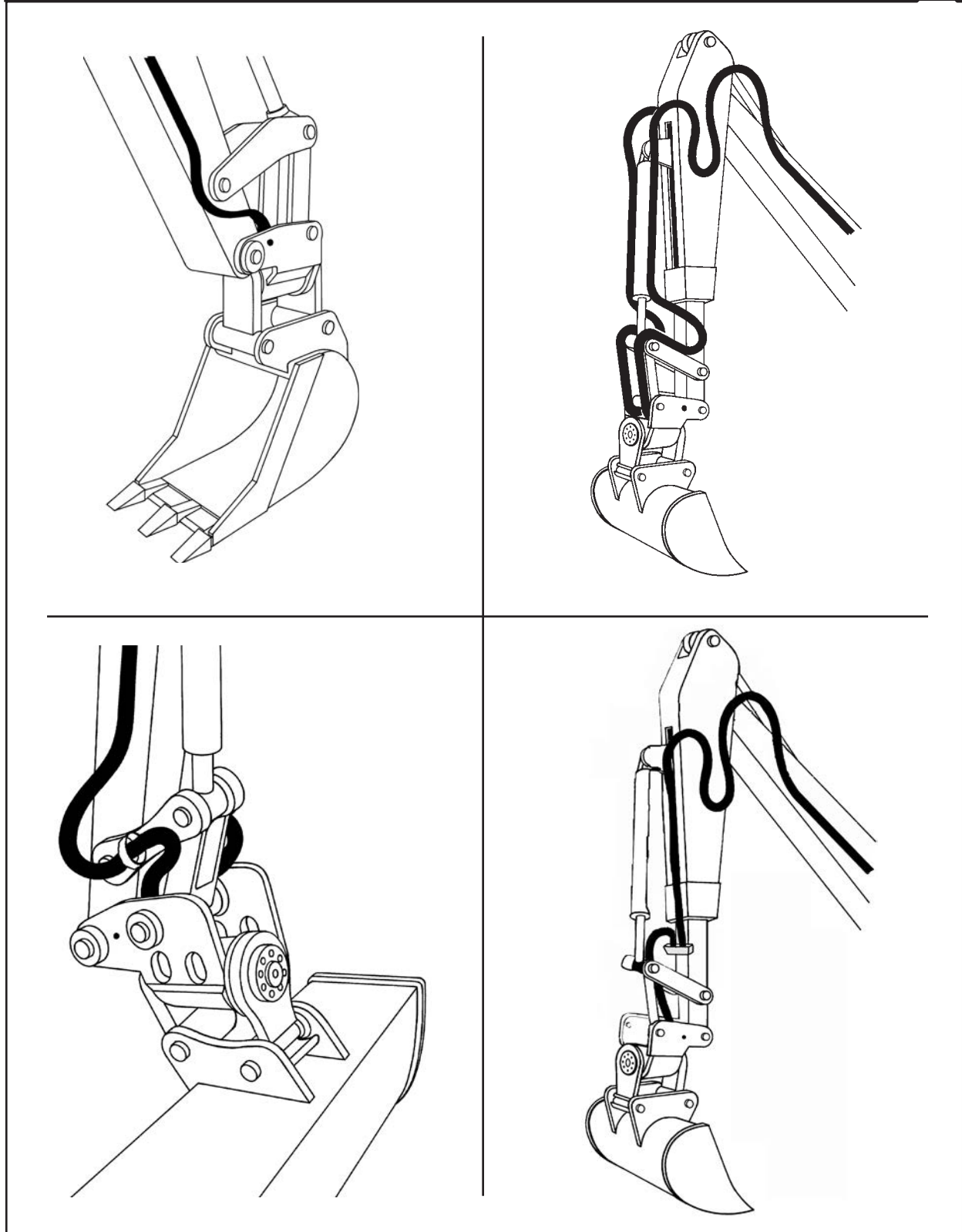

Maintenance

Daily

1. Grease the thrust washers at the two grease fittings with a high quality Lithium-based grease. Apply grease until clean grease flows from the grease reliefs. Severe operating conditions such as abrasive dust or prolonged submersion in water may require more frequent grease applications.
2. Make sure the grease reliefs are functioning properly. Open or replace non-functioning grease reliefs immediately.

NOTICE

Never replace the grease relief valves with grease fittings or plugs.

NOTICE

Do not operate the PowerTilt if the grease reliefs are not functioning.

3. Inspect the PowerTilt for loose, worn or damaged components and replace or repair immediately.
4. Mounting pins should be greased upon installation and thereafter according to the equipment manufacturer's instructions.

Monthly

Check shaft end play. When the end play exceeds 0.38 mm, the end cap must be tightened. See page 14 and 15 for detailed instructions.

Adjusting Endplay

Checking Shaft Endplay

Measure the end play with a dial indicator. Rotate the PowerTilt all the way one direction and zero out the dial indicator while the PowerTilt is still pressurized. Rotate the PowerTilt all the way the other direction. Take the reading from the dial indicator while still pressurized. Maximum shaft endplay allowed is 0.38 mm (0.015”) due to thrust washer wear before tightening the end cap is required. Allowing more endplay can cause damage to the shaft, end cap and housing.



- 1. Loosen and remove the lock ring bolts.

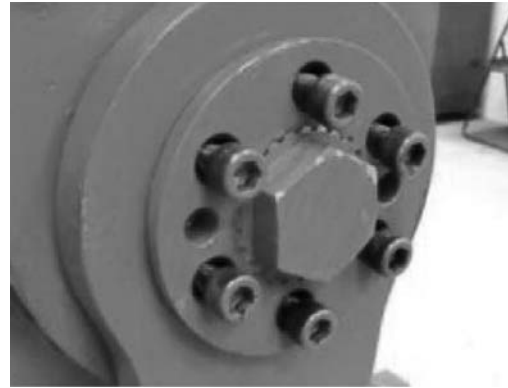

- 2. Remove the lock ring by turning in the set screws.

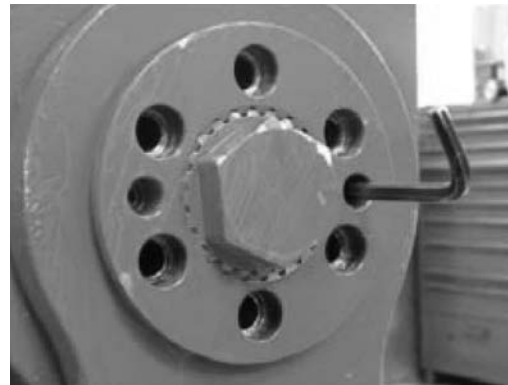

NOTICE

For easier disassembly / assembly of the lock ring, it is recommended to loosen the bolts on the opposite end of the shaft.

Adjusting Endplay

The end-cap can be tightened a total of 1/2 turn safely before the thrust washers should be replaced. Tightening beyond 1/2 turn could cause the end cap to gall to the shaft.

Adjusting Endplay

- The end cap with the threaded holes is now visible under the lock ring.

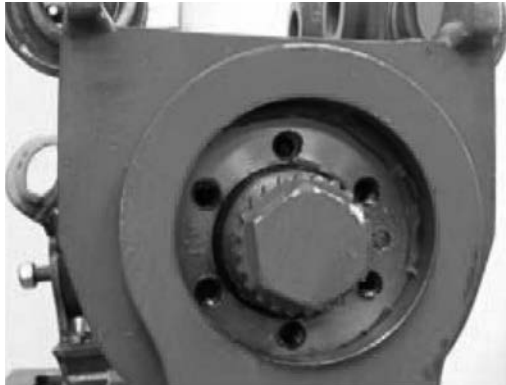

- Now mount the re-adjustment tool and tighten the end cap with the torque wrench by turning it clockwise or hydraulically by holding the end cap stationary and pressurizing port P2 to the values in table on page 41.



NOTICE

Install lock ring before operating the PowerTilt again.

Neglecting to do so poses the risk that the shaft might rotate in relation to the end cap and the adjusted torque changes, when the PowerTilt is operated.

Measuring PowerTilt Side to Side Movement

The table below shows the tolerances allowed for total side to side movement, which includes actual gear backlash, hydraulic seal movement / compression, and oil compression. No endplay.

Maximum Backlash Measured at Outside Diameter of Shaft for a New PowerTilt

Model	Measurement
PT-6	2.0 mm
PT-7	2.4 mm
PT-8	2.7 mm
PT-9	3.1 mm
PT-10	3.5 mm
PT-11	3.8 mm
PT-12	4.1 mm

These measurements represent 1.5° of backlash. Measurements should be taken with the bucket in the air and with the machine shut off and pressure relieved. With a wide bucket installed, a person can stand on one corner of the bucket, make matching marks on the shaft and housing per the illustration below, then stand on the other corner of the bucket and make a second mark on the housing and take a measurement between the marks on the housing. This method is not exact but can be useful to help determine where movement is coming from. Air in the system or shaft endplay (see next section) can contribute to the perceived backlash and should be watched for.

Adjusting Endplay

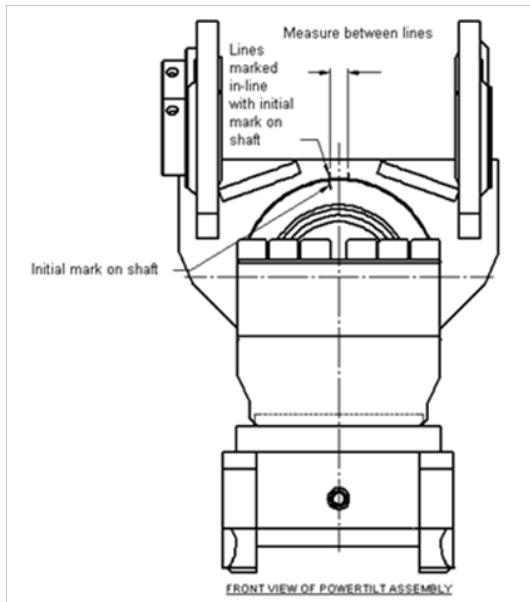

A new unit should have 1 – 1.5° total backlash that includes actual clearance between the internal splines, seal movement and a small amount of oil compression. If more backlash is noted on a new PowerTilt, the cause is most likely air in the PowerTilt. Bleed the air out of the PowerTilt and check the hydraulic oil level in the tank. A low oil level in the hydraulic tank can introduce air into the oil.

Troubleshooting Guide

Problem	Possible Cause	Solution
PowerTilt does not hold position	Excessive down pressure applied by the excavator can cause buildup of pressure in the PowerTilt which is opening the cross port relief valve. Control valve leaking oil. Faulty cross port relief valve. Seals leaking oil.	This is normal. The integral cross port relief valve is designed to protect the PowerTilt from excessive internal pressures that can damage the unit. Test, repair or replace as needed. Remove the integral cross port relief valve and visually inspect for damage or debris. Check pressure setting of the cross port relief valve which can be found in the Tool Circuit Requirements Chart shown on page 11. Test and replace seals as needed.
PowerTilt swings in only one direction.	Single directional control valve is being used. Cross port relief valve damaged. Both lines connected to either both P1 or P2 ports of PowerTilt.	Replace with bi-directional control valve. Inspect, test and replace as needed. Refer to page 16 for proper port connection location.
PowerTilt has spongy feel side to side.	Air in PowerTilt or hydraulic circuit. Diameter of tubing/hoses larger or longer than recommended.	Bleed air from circuit and check for cause. Install new tubing/hoses with recommended diameters. Install pilot operated check valve in lines as close as possible to PowerTilt.
Forward and backward movement of shaft in the housing (shaft endplay).	Worn or missing thrust washers.	Tighten end cap according to the End Cap Torque Chart on page 38. Replace or install thrust washers if necessary.
Side to side bucket movement.	Some movement is normal due to clearance required between internal spline teeth.	Normal movement is 1° to 1-1/2°. If greater, check shaft end play; excessive end play can contribute to side to side movement. If shaft end play is not within acceptable limits, consult PowerTilt AG.
PowerTilt will not accept grease at fittings.	Grease relief valve is not functioning, or it has been replaced with a grease fitting or plug.	Clean or replace grease relief valves.
PowerTilt squeals at maximum tilt or when stalled.	Relief valve is opening from machine pressure.	Check relief pressure, and if within range, reduce the pressure from the machine to below relief pressure setting. See page 10 for pressure settings.

Tools Required

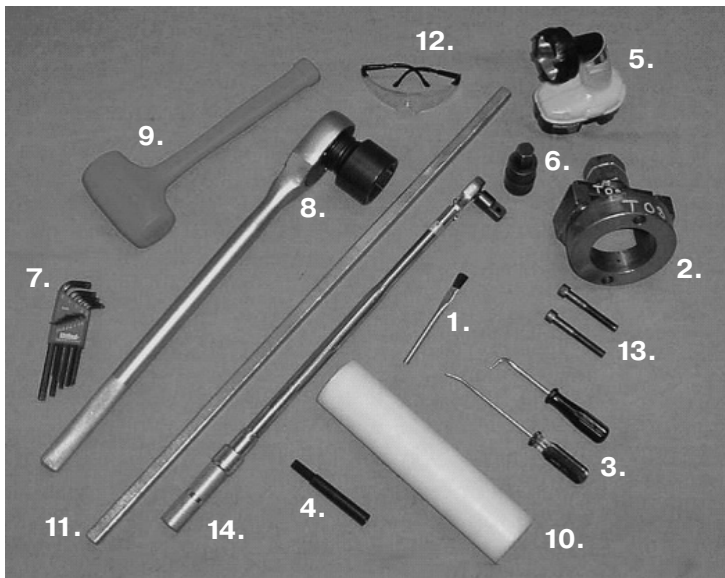

Several basic tools are required for the disassembly and reassembly of the PowerTilt. The suggested tools are outlined below:

1. Brush
2. Customized end cap tool
3. Customized seal tools
4. Permanent marker
5. Flashlight
6. Hex driver
7. Hex wrenches
8. Large socket wrench
9. Plastic or rubber mallet
10. Plastic mandrel
11. Pry bar
12. Safety glasses
13. Threaded bolts
14. Torque wrench

NOTICE All fasteners are metric.

Making a Seal Tool

The seal tool is merely a customized standard flat head screwdriver.

1. Heat the flat end with a torch until it glows.
2. Secure the heated end of the screwdriver in a vise and bend the heated end to a slight radius.
3. Round off all sharp edges of the heated tip to a polished finish. The tool may be modified slightly to your own personal preference.



	CAUTION
	<p>To avoid injury:</p> <p>Be careful when handling the screwdriver when hot.</p>

PT Assembly Drawing

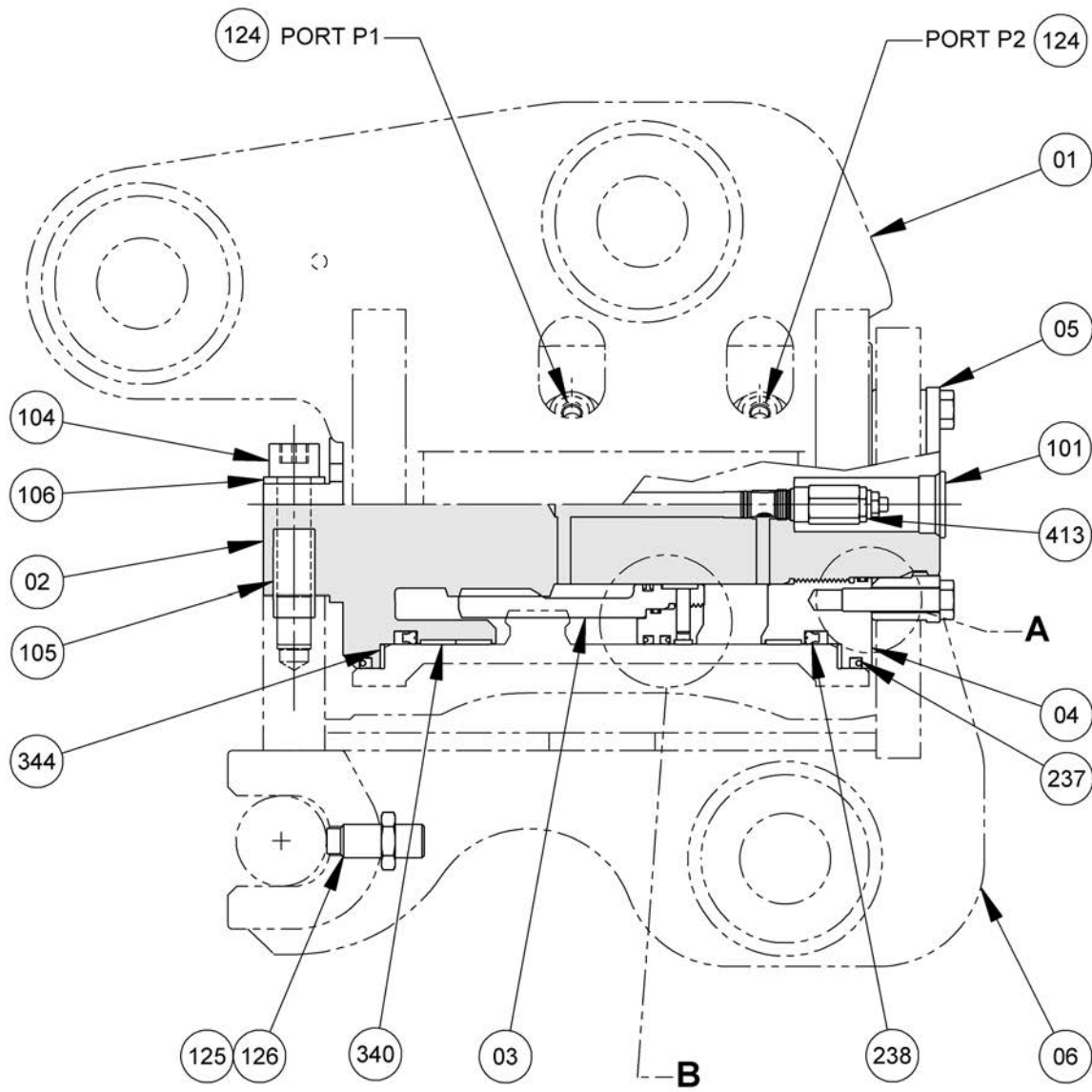

SEE PAGE 20

PT Assembly Drawing

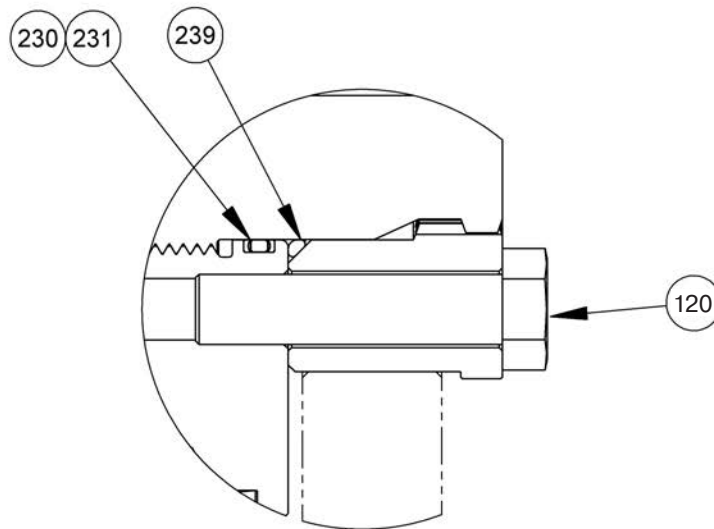
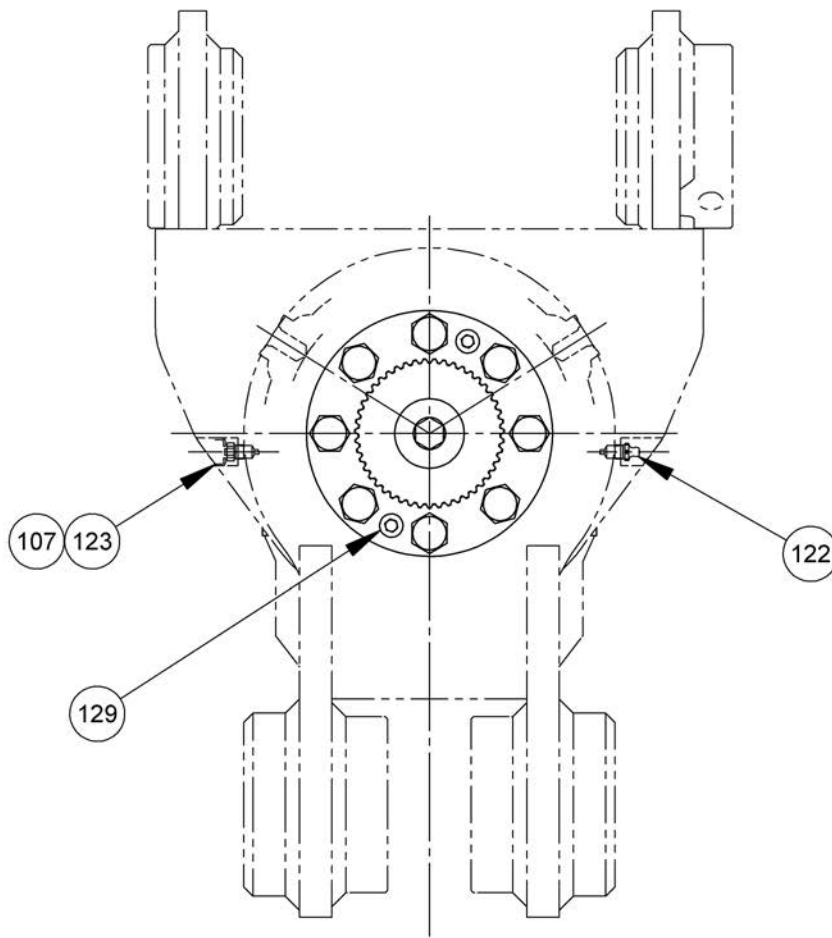

PTA Assembly Drawing

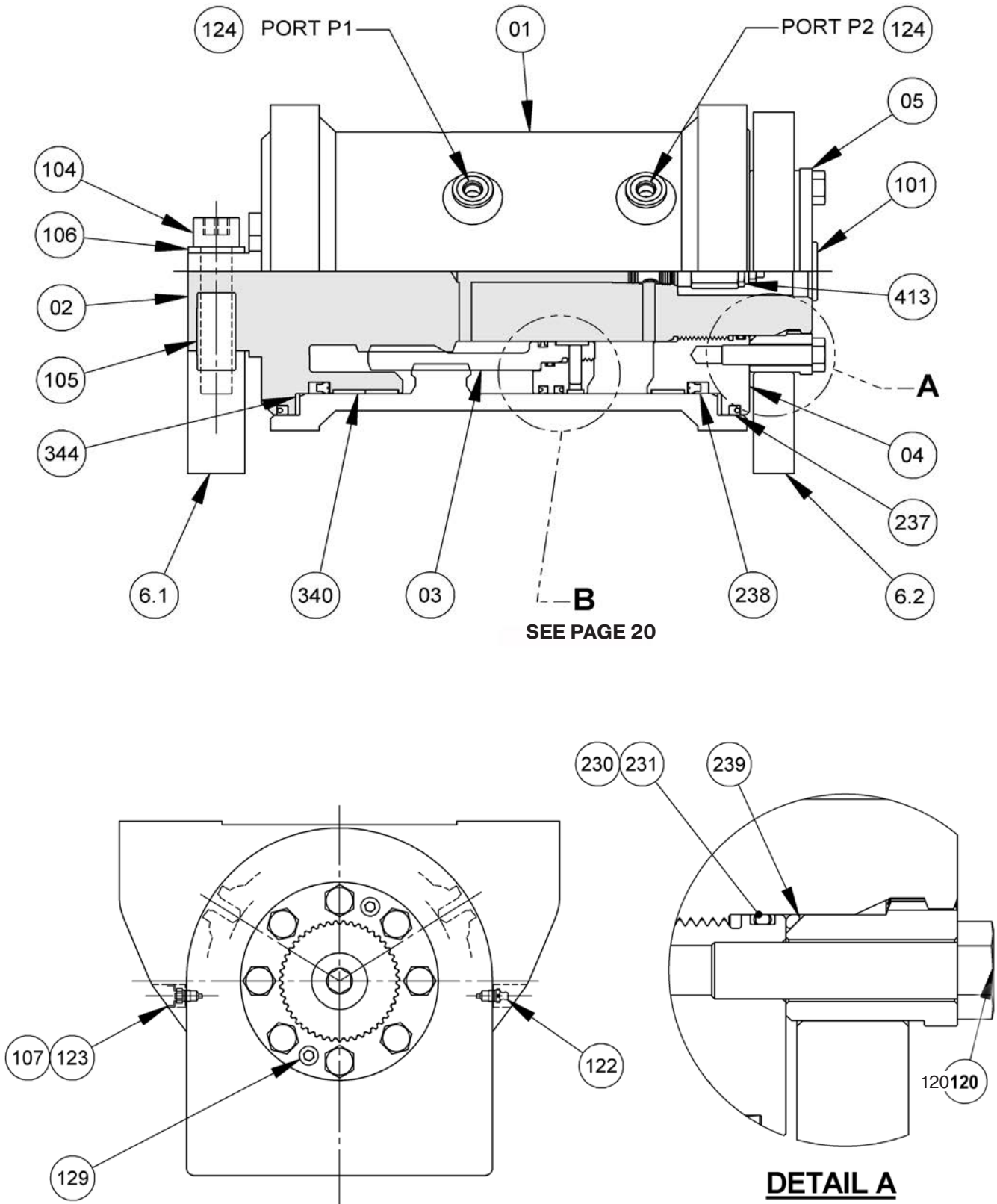

PTB Assembly Drawing

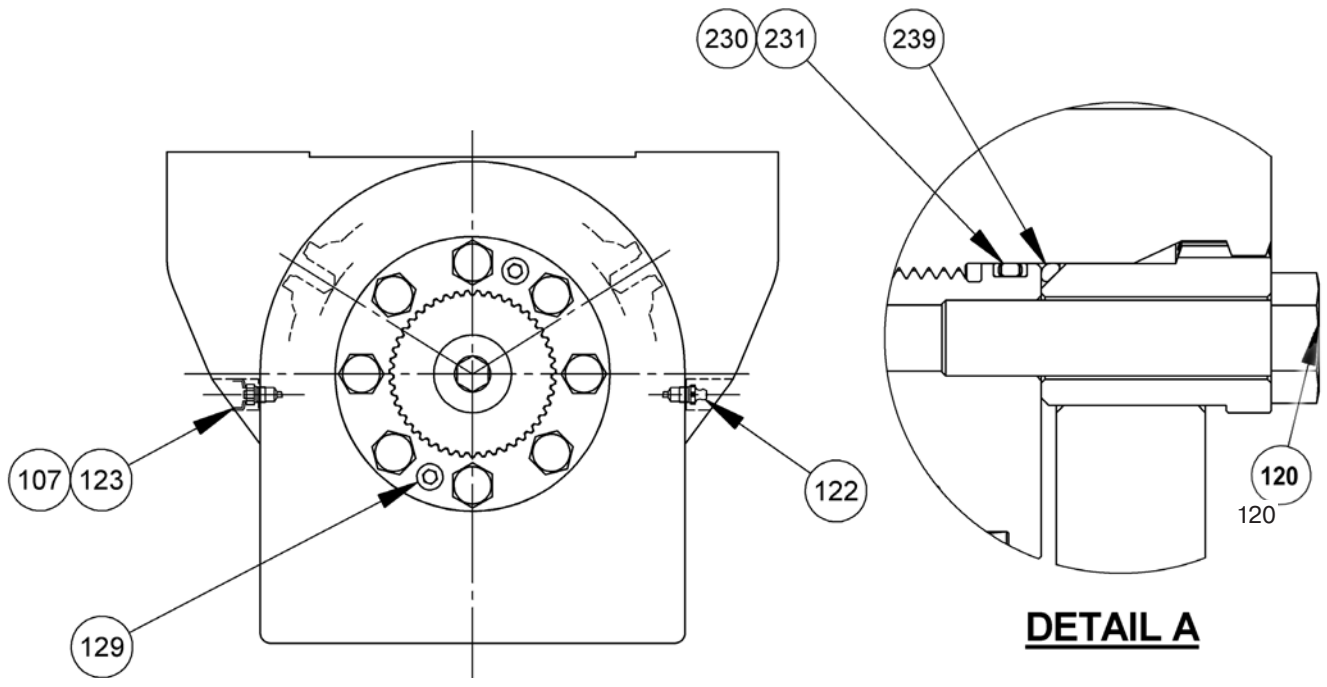
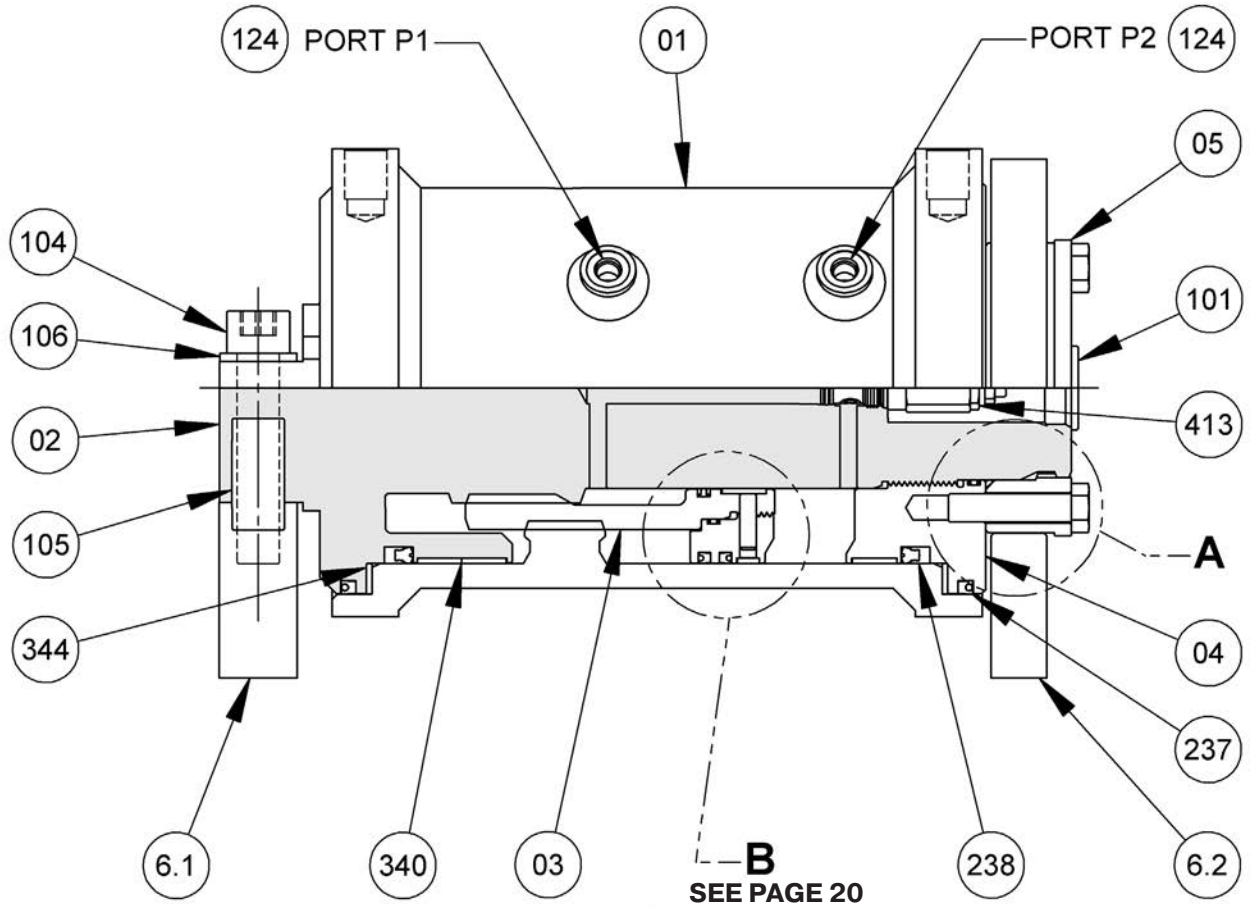

PT Piston Drawing

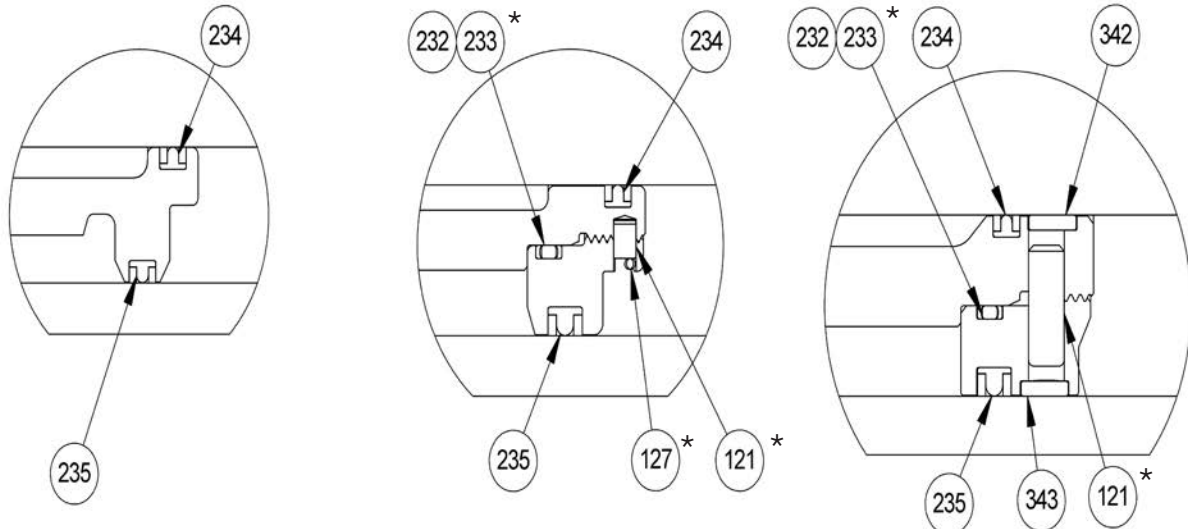

DETAIL B
MODEL 06

DETAIL B
MODEL 07

DETAIL B
MODEL 08

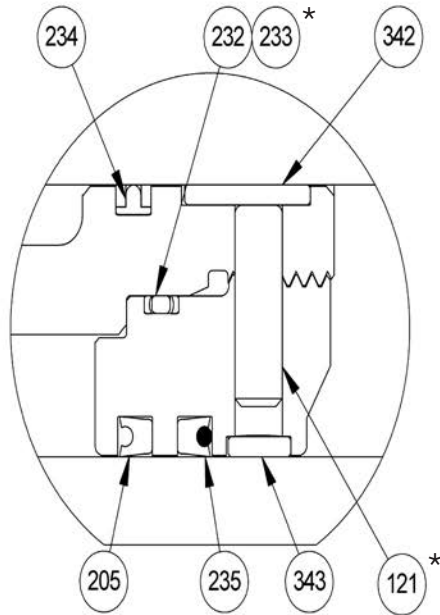

DETAIL B
MODEL 09

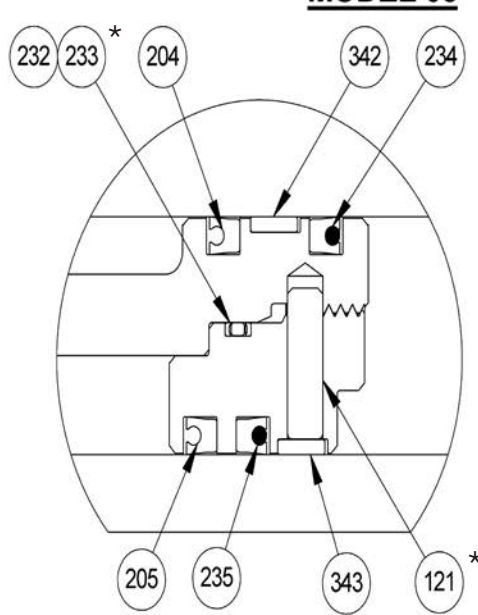

DETAIL B
MODELS 10, 11 & 12

* Service normally not required.

PT Exploded View

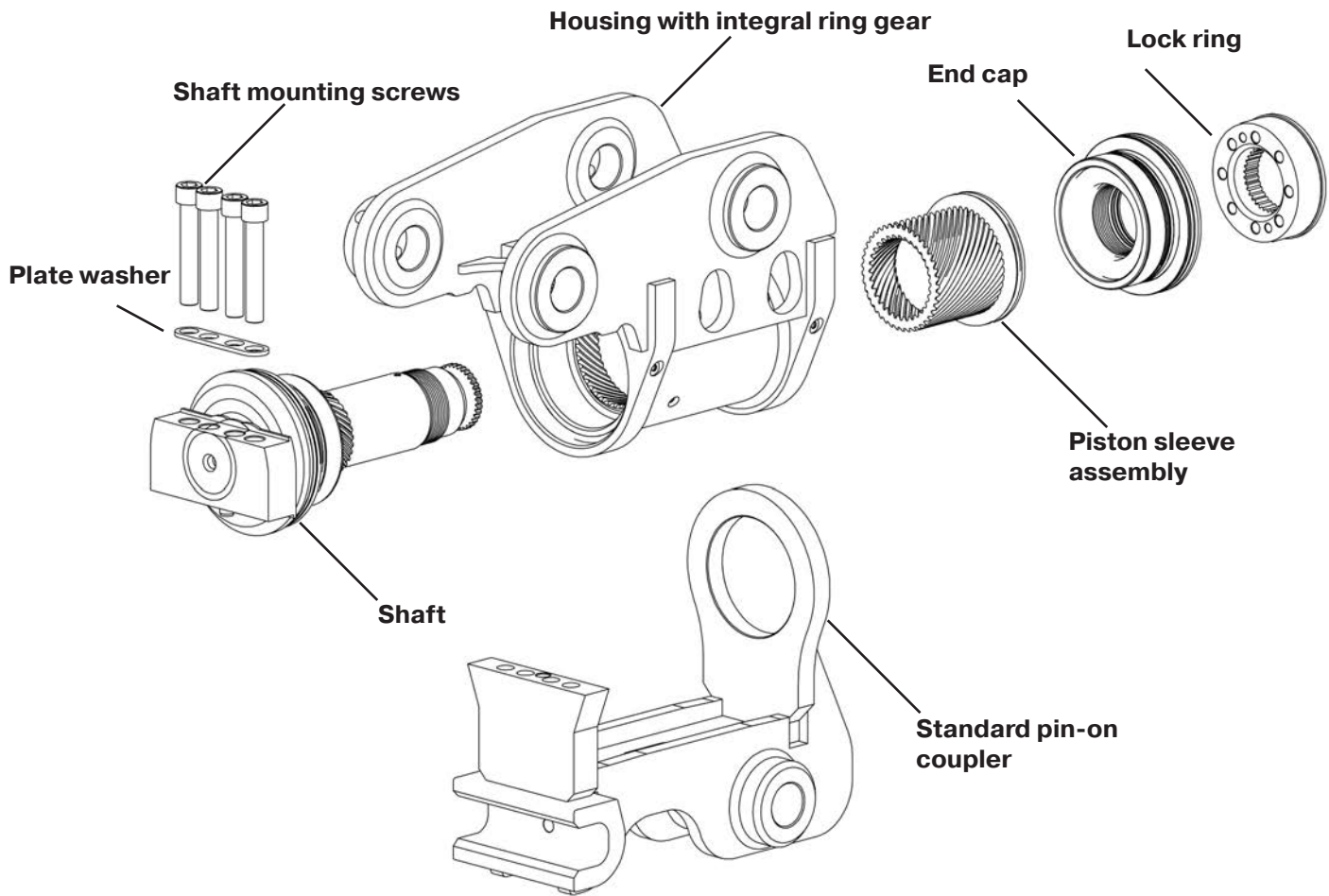

Parts List - PT-06

Parts

Part Number	Item #	Description	Qty
Consult Factory	01	Housing - PT (with side plates and bosses)	1
67750PB	01	Housing - PTA (BSPP ports, no side plates or bosses)	1
67750PS	01	Housing - PTA (SAE Ports, no side plates or bosses)	1
67708PB	01	Housing - PTB (BSPP ports, no side plates or bosses)	1
67708PS	01	Housing - PTB (SAE ports, no side plates or bosses)	1
67535-H	02	Shaft 180 (with relief valve cavity)	1
67854	02	Shaft 180 (without relief valve cavity)	1
67528	03	Piston Sleeve 180	1
62397	04	End Cap	1
66413-H	05	Coupler (not available)	1
Multiple	06	Torque (not available)	1
Multiple	6.1	Torque Foot (not available)	1
Multiple	6.2	Idler Foot (not available)	1
67980	101	Shaft Port Plug (SAE-20 Hex head plug modified)	1
9551048	104	Torque Foot Screw (SHCS; M16-2.0-100 Grade 12.9)	4
965003-H	105	Torque Foot Dowel Pin (12mm x 30mm hardened)	1
6364-1	106	Torque Foot Washer	1
74897	107	**Grease Relief Valve Cover	2
9551021	120	Lock Ring Screw (SHCS; M12-1.75-045 Grade 12.9)	6
936002	122	Grease Fitting (Balcrank, 5000 Lincoln, 1/8-27 NPT)	2
938001	123	**Grease Relief Valve (50500, 1/8-27 NPT, Alemite 400-650 PSI)	2
977015	124	Port Plug (BSPP G1/4 hollow hex)	2
9601005	125	Jacking Screw (socket head set screw M16-2.00-045 Grade 10.9)	1
9511002	126	Jam Nut (M16-2.00 thin Grade 10.9)	1
9601008	129	Lock Ring Set Screw (SHSS; M12-1.75-020, half-dog Grade 10.9)	2
949020	413	Cross-port Relief Valve	1

**Items included in seal kit

Serial Number Fit by Seal Kit

Part Number	Between Beginning #	And Ending #	Beginning Year Made	End Year Made	Comment
S66664	T61757	T68574	2005	2012	First number after "T" designates model size.
	552245	898674	2012	2017	S/N has no relation to model size. Need to know model size.
	HE1064	HE1064	2015	2015	
	A14485	A98431	2018	2018	
	B8591	B16516	2019	2019	

Seal and Bearing Kits

Part Number	Item #	Description	Qty
S66664		Seal Kit (parts listed below included)	1
		relief valve seal kit	1
	107	Grease relief Valve Cover	2
	123	Grease relief Valve	2
	230	Seal	1
	231	Seal	2
	234	Seal	1
	235	Seal	1
	237	Seal	2
	238	Seal	2
239	O-Ring	1	
63791		Bearing Kit (parts listed below included)	1
	341	Bearing	2
	344	Thrust Washer	2

Seal and Bearing kits can be ordered online at <http://www.parker.com/helac>

Parts List - PT-07

Parts

Part Number	Item #	Description	Qty
Consult Factory	01	Housing - PT (with side plates and bosses)	1
67653PB	01	Housing - PTA (BSPP ports, no side plates or bosses)	1
67653PS	01	Housing - PTA (SAE Ports, no side plates or bosses)	1
67652PB	01	Housing - PTB (BSPP ports, no side plates or bosses)	1
67652PS	01	Housing - PTB (SAE ports, no side plates or bosses)	1
67496-H	02	Shaft 180 (with relief valve cavity)	1
67588	02	Shaft 180 (without relief valve cavity)	1
S67493	03	Piston Sleeve 180	1
62372	04	End Cap	1
65991-H	05	Lock Ring	1
Multiple	06	Coupler (not available)	1
Multiple	6.1	Torque Foot (not available)	1
Multiple	6.2	Idler Foot (not available)	1
977031	101	Shaft Port Plug (SAE-20 hollow hex plug)	1
9551042	104	Torque Foot Screw (SHCS; M20-2.50-120 Grade 12.9)	4
965002	105	Torque Foot Dowel Pin (M16 x 40 mm harden)	1
63121	106	Torque Foot Washer	1
74897	107	**Grease Relief Valve Cover	2
9551021	120	Lock ring Screw (SHCS; M12-1.75-045 Grade 12.9)	8
965006-H	121	Cross Pin (6 mm x 8 mm harden)	2
936002	122	Grease Fitting (Balcrank, 5000 Lincoln, 1/8-27 NPT)	2
938001	123	**Grease Relief Valve (50500, 1/8-27 NPT, Alemite 400-650 PSI)	2
977015	124	Port Plug (BSPP G1/4 hollow hex)	2
9601005	125	Jacking Screw (socket head set screw M16-2.00-045 Grade 10.9)	1
9511002	126	Jam Nut (M16-2.00 thin Grade 10.9)	1
64320	127	**Dowel Pin Retainer Wire	1
9601008	129	Lock Ring Set Screw (SHSS; M12-1.75-020, half-dog Grd 10.9)	2
949020	413	Cross-port Relief Valve Cartridge	

**Items included in seal kit

Seal and Bearing Kits

Part Number	Item #	Description	Qty
S67520		Seal Kit (parts listed below included)	1
		Relief Valve Seal Kit	1
	107	Grease relief Valve Cover	2
	123	Grease relief Valve	2
	230 / 239	Seal	2
	231	Seal	2
	232	O-Ring	1
	233	Back-up Ring	2
	234	Seal	1
	235	Seal	1
	237	Seal	2
238	Seal	2	
63787		Seal Kit (parts listed below included)	1
		Relief Valve Seal Kit	1
	107	Grease Relief Valve Cover	2
	123	Grease Relief Valve	2
	230	Seal	2
	231	Seal	2
	232	O-Ring	1
	233	Back-up Ring	2
	234	Seal	1
	235	Seal	1
	237	Seal	2
238	Seal	2	
63788		Bearing Kit (parts listed below included)	1
	340 / 341	Bearing	2
	342	Bearing	1
	344	Thrust Washer	2

Seal and Bearing kits can be ordered online at <http://www.parker.com/helac>

Parts List - PT-07

Serial Number Fit by Seal Kit

<i>Part Number</i>	<i>Between Beginning #</i>	<i>And Ending #</i>	<i>Beginning Year Made</i>	<i>End Year Made</i>	<i>Comment</i>
S67520	T73414	T79223	2005	2012	First number after "T" designates model size.
	TC76017	TC76764	2009	2010	First number after "TC" designates model size.
	552242	955672	2012	2017	S/N has no relation to model size. Need to know model size.
	HE1007	HE1063	2013	2014	
	A10902	A98531	2018	2018	
	B1533	B19173	2018	2019	
63787	T71986	T73413	2003	2005	TT-07 seal kit used

Parts List - PT-08

Parts

Part Number	Item #	Description	Qty
Consult Factory	01	Housing - PT (with side plates and bosses)	1
67413PB	01	Housing - PTA (BSPP ports, no side plates or bosses)	1
67413PS	01	Housing - PTA (SAE Ports, no side plates or bosses)	1
67414PB	01	Housing - PTB (BSPP ports, no side plates or bosses)	1
67414PS	01	Housing - PTB (SAE ports, no side plates or bosses)	1
66782	02	Shaft 180 (with relief valve cavity)	1
66799	02	Shaft 180 (without relief valve cavity)	1
S66785	03	Piston Sleeve 180	1
62639-H	04	End Cap	1
66352	05	Lock Ring	1
Multiple	06	Coupler (not available)	1
Multiple	6.1	Torque Foot (not available)	1
Multiple	6.2	Idler Foot (not available)	1
977031	101	Shaft Port Plug (SAE-20 hollow hex plug)	1
9551005	104	Torque Foot Screw (SHCS; M24-3.0-120; Grade 12.9)	4
62684-H	105	Torque Foot Dowel Pin	1
63122	106	Torque Foot Washer	1
74897	107	**Grease Relief Valve Cover	2
9541022	120	Lock Ring Hex Screw (HHCS; M16-2.0-070; Grade 10.9)	6
964011	121	Cross Pin (.375" x 1.00" hardened)	2
936002	122	Grease Fitting (Balcrank, 5000 Lincoln, 1/8-27 NPT)	2
938001	123	**Grease Relief Valve (50500, 1/8-27 NPT, Alemite 400-650 PSI)	2
977015	124	Port Plug (BSPP G1/4 hollow hex)	2
9601005	125	Jacking Screw (socket head set screw M16-2.00-045 Grade 10.9)	1
9511002	126	Jam Nut (M16-2.00 thin Grade 10.9)	1
9601009	129	Lock Ring Set Screw (M16-2.00-030, Grd 10.9)	2
949020	413	Cross-port Relief Valve Cartridge	1

**Items included in seal kit

Seal and Bearing Kits

Part Number	Item #	Description	Qty
S66935		Seal Kit (parts listed below included)	1
		Relief Valve Seal Kit	1
	107	Grease relief Valve Cover	2
	123	Grease relief Valve	2
	230 / 239	Seal	2
	231	Seal	2
	232	O-Ring	1
	233	Back-up Ring	2
	234	Seal	1
	235	Seal	1
	237	Seal	2
238	Seal	2	
S63092		Seal Kit (parts listed below included)	1
		Relief Valve Seal Kit	1
	107	Grease Relief Valve Cover	2
	123	Grease Relief Valve	2
	230	Seal	1
	231	Seal	2
	232	O-Ring	1
	233	Back-up Ring	2
	234	Seal	1
	235	Seal	1
	237	Seal	2
238	Seal	2	
63044		Bearing Kit (parts listed below included)	1
	340	Bearing	2
	341	Bearing	1
	342	Bearing	1
	343	Bearing	1
	344	Thrust Washer	2

Seal and Bearing kits can be ordered online at <http://www.parker.com/helac>

Parts List - PT-08

Serial Number Fit by Seal Kit

<i>Part Number</i>	<i>Between Beginning #</i>	<i>And Ending #</i>	<i>Beginning Year Made</i>	<i>End Year Made</i>	<i>Comment</i>
S66935	T81946	T88791	2004	2012	First number after "T" designates model size.
	552277	900802	2012	2018	S/N has no relation to model size. Need to know model size.
	A11098	A99932	2018	2018	
	B1988	B25462	2018	2019	
	HE1009	HE1062	2013	2013	
Odd numbers: 3073, 3074, 307533726, 112578, 112579, 112581, 112582					
S63092	T81148	T81945	2003	2004	TT-08 seal kit used

Parts List - PT-09

Parts

Part Number	Item #	Description	Qty
Consult Factory	01	Housing - PT (with side plates and bosses)	1
67366PB	01	Housing - PTA (BSPP ports, no side plates or bosses)	1
67366PS	01	Housing - PTA (SAE Ports, no side plates or bosses)	1
67367PB	01	Housing - PTB (BSPP ports, no side plates or bosses)	1
67367PS	01	Housing - PTB (SAE ports, no side plates or bosses)	1
67355	02	Shaft 140	1
S68434	03	Piston Sleeve 140	1
62201-H	04	End Cap	1
66073-H	05	Lock Ring	1
Multiple	06	Coupler (not available)	1
Multiple	6.1	Torque Foot (not available)	1
Multiple	6.2	Idler Foot (not available)	1
977031	101	Shaft Port Plug (SAE-20 hollow hex plug)	1
9551005	104	Torque Foot Screw (SHCS; M24-3.0-120; Grade 12.9)	4
62308	105	Torque Foot Dowel Pin	1
63123	106	Torque Foot Washer	1
74897	107	**Grease Relief Valve Cover	2
9541004	120	Lock Ring Screw (HHCS; M16-2.0-080; Grade 10.9)	6
964012	121	Cross Pin (.375" x 1.00" hardened)	2
936002	122	Grease Fitting (Balcrank, 5000 Lincoln, 1/8-27 NPT)	2
938001	123	**Grease Relief Valve (50500, 1/8-27 NPT, Alemite 400-650 PSI)	2
977015	124	Port Plug (BSPP G1/4 hollow hex)	2
9601007	125	Jacking Screw (socket head set screw M24-3.00-070 Grade 10.9)	1
9511001	126	Jam Nut (M24-3.00 thin Grade 10.9)	1
9601009	129	Lock Ring Set Screw (M16-2.00-030, Grd 10.9)	2
949020	413	Cross-port Relief Valve Cartridge	1

**Items included in seal kit

Serial Number Fit by Seal Kit

Part Number	Between Beginning #	And Ending #	Beginning Year Made	End Year Made	Comment
S67347	T93000	T96496	2005	2012	First number after "T" designates model size.
	552243	899808	2012	2018	S/N has no relation to model size. Need to know model size.
	A15321	A99995	2018	2018	
	B2027	B24932	2018	2019	
	HE1004	HE1050	2013	2013	
62506-H	T91370	T92151	2003	2005	TT-09 seal kit used
	Also fits all TT/TTB/TBB-09 models				

Seal and Bearing Kits

Part Number	Item #	Description	Qty
S67347		Seal Kit (parts listed below included)	1
		Relief Valve Seal Kit	1
	107	Grease relief Valve Cover	2
	123	Grease relief Valve	2
	205	Seal	1
	230 / 239	Seal; O-Ring	2
	231	Seal; B/U Ring	2
	232	Seal, O-Ring	1
	233	Seal; B/U Ring	2
	234	Seal	1
	235	Seal	1
	237	Seal	2
	238	Seal	2
62506-H		Seal Kit (parts listed below included)	1
		Relief Valve Seal Kit	1
	107	Grease Relief Valve Cover	2
	123	Grease Relief Valve	2
	205	Seal	1
	230	Seal; O-Ring	1
	231	Seal; B/U Ring	2
	232	Seal; O-Ring	1
	233	Seal; B/U Ring	2
	234	Seal	1
	235	Seal	1
	237	Seal	2
	238	Seal	2
62507		Bearing Kit (parts listed below included)	1
	342	Bearing	1
	343	Bearing	1
	340/341	Bearing	3
	344	Thrust Washer	2

Seal and Bearing kits can be ordered online at

<http://www.parker.com/helac>

Parts List - PT-10

Parts

Part Number	Item #	Description	Qty
Consult Factory	01	Housing - PT (with side plates and bosses)	1
67719PB	01	Housing - PTA (BSPP ports, no side plates or bosses)	1
67719PS	01	Housing - PTA (SAE Ports, no side plates or bosses)	1
67720PB	01	Housing - PTB (BSPP ports, no side plates or bosses)	1
67720PS	01	Housing - PTB (SAE ports, no side plates or bosses)	1
67685	02	Shaft 140	1
S60533	03	Piston Sleeve 140	1
60833-H	04	End Cap	1
67129	05	Lock Ring	1
Multiple	06	Coupler (not available)	1
Multiple	6.1	Torque Foot (not available)	1
Multiple	6.2	Idler Foot (not available)	1
977031	101	Shaft Port Plug (SAE-20 hollow hex plug)	1
9551003	104	Torque Foot Screw (SHCS; M30-3.5-140; Grade 12.9)	4
62308	105	Torque Foot Dowel Pin	1
63124	106	Torque Foot Washer	1
74897	107	**Grease Relief Valve Cover	2
9541029	120	Lock Ring Screw (HHCS; M16-2.0-090; Grade 10.9)	8
964012	121	Cross Pin (.375" x 1.25" hardened)	2
936002	122	Grease Fitting (Balcrank, 5000 Lincoln, 1/8-27 NPT)	2
938001	123	**Grease Relief Valve (50500, 1/8-27 NPT, Alemite 400-650 PSI)	2
977015	124	Port Plug (BSPP G1/4 hollow hex)	2
9601007	125	Jacking Screw (socket head set screw M24-3.00-070 Grade 10.9)	1
9511001	126	Jam Nut (M24-3.00 thin Grade 10.9)	1
9601009	129	Lock Ring Set Screw (M16-2.00-030, Grd 10.9)	2
949020	413	Cross-port Relief Valve Cartridge	1

**Items included in seal kit

Seal and Bearing Kits

Part Number	Item #	Description	Qty
S62104		Seal Kit (parts listed below included)	1
		Relief Valve Seal Kit	1
	107	Grease relief Valve Cover	2
	123	Grease relief Valve	2
	204	Seal	1
	205	Seal	1
	230 / 239	O-Ring	2
	231	Back-up Ring	2
	232	O-Ring	1
	233	Back-up Ring	2
	234	Seal	1
	235	Seal	1
	237	Seal	2
	238	Seal	2
62342		Bearing Kit (parts listed below included)	1
	340	Bearing	3
	342	Bearing	1
	343	Bearing	2
	344	Thrust Washer	2

Seal and Bearing kits can be ordered online at <http://www.parker.com/helac>

Serial Number Fit by Seal Kit

Part Number	Between Beginning #	And Ending #	Beginning Year Made	End Year Made	Comment
S62104	T101675	T103555	2004	2012	First two numbers after "T" designates model size.
	552244	900787	2012	2018	S/N has no relation to model size. Need to know model size.
	A16108	A92194	2018	2018	
	B5223	B27121	2019	2019	
	HE1001	HE1052	2013	2013	
Also fits all TT/TTB/TBB-10 models.					

Parts List - PT-11

Parts

Part Number	Item #	Description	Qty
Consult Factory	01	Housing - PT (with side plates and bosses)	1
67908PB	01	Housing - PTA (BSPP ports, no side plates or bosses)	1
67908PS	01	Housing - PTA (SAE Ports, no side plates or bosses)	1
67907PB	01	Housing - PTB (BSPP ports, no side plates or bosses)	1
67907PS	01	Housing - PTB (SAE ports, no side plates or bosses)	1
67826	02	Shaft 140	1
S67823	03	Piston Sleeve 140	1
63833	04	End Cap	1
66467-H	05	Lock Ring	1
Multiple	06	Coupler (not available)	1
Multiple	6.1	Torque Foot (not available)	1
Multiple	6.2	Idler Foot (not available)	1
977031	101	Shaft Port Plug (SAE-20 hollow hex plug)	1
9551031	104	Torque Foot Screw (SHCS; M30-3.5-140; Grade 12.9)	6
62308	105	Torque Foot Dowel Pin	1
63939	106	Torque Foot Washer	1
74897	107	**Grease Relief Valve Cover	2
9541029	120	Lock Ring Screw (HHCS; M16-2.0-090; Grade 10.9)	8
964015	121	Cross Pin (.437" x 1.50" hardened)	2
936002	122	Grease Fitting (Balcrank, 5000 Lincoln, 1/8-27 NPT)	2
938001	123	**Grease Relief Valve (50500, 1/8-27 NPT, Alemite 400-650 PSI)	2
977015	124	Port Plug (BSPP G1/4 hollow hex)	4
9601007	125	Jacking Screw (socket head set screw M24-3.00-070 Grade 10.9)	1
9511001	126	Jam Nut (M24-3.00 thin Grade 10.9)	1
9601009	129	Lock Ring Set Screw (M16-2.00-030, Grd 10.9)	2
949020	413	Cross-port Relief Valve Cartridge	1

**Items included in seal kit

Seal and Bearing Kits

Part Number	Item #	Description	Qty
S67897		Seal Kit (parts listed below included)	1
		Relief Valve Seal Kit	1
	107	Grease relief Valve Cover	2
	123	Grease relief Valve	2
	204	Seal	1
	205	Seal	1
	230 / 239	O-Ring	2
	231	Back-up Ring	2
	232	O-Ring	1
	233	Back-up Ring	2
	234	Seal	1
	235	Seal	1
	236	Seal	2
238	Seal	2	
64034		Bearing Kit (parts listed below included)	1
	340	Bearing	2
	341	Bearing	1
	342	Bearing	1
	343	Bearing	1
	344	Thrust Washer	2

Seal and Bearing kits can be ordered online at

<http://www.parker.com/helac>

Serial Number Fit by Seal Kit

Part Number	Between Beginning #	And Ending #	Beginning Year Made	End Year Made	Comment
S67897	T11263	T111106	2005	2012	First two numbers after "T" designates model size.
	555448	900826	2012	2018	S/N has no relation to model size. Need to know model size.
	A11037	A88662	2018	2018	
	B16654	B16737	2018	2019	

Parts List - PT-12

Parts

Part Number	Item #	Description	Qty
Consult Factory	01	Housing - PT (with side plates and bosses)	1
68023PB	01	Housing - PTA (BSPP ports, no side plates or bosses)	1
68024PB	01	Housing - PTB (BSPP ports, no side plates or bosses)	1
67140	02	Shaft 140	1
S60819	03	Piston Sleeve 140	1
60822	04	End Cap	1
68003	05	Lock Ring	1
Multiple	06	Coupler (not available)	1
Multiple	6.1	Torque Foot (not available)	1
Multiple	6.2	Idler Foot (not available)	1
977031	101	Shaft Port Plug (SAE-20 hollow hex plug)	1
9551022	104	Torque Foot Screw (SHCS; M30-3.5-180; Grade 12.9)	6
62308	105	Torque Foot Dowel Pin	1
63205	106	Torque Foot Washer	1
68331	107	**Grease Relief Valve Cover	2
9541006	120	Lock Ring Screw (HHCS; M20-2.5-100; Grade 10.9)	8
964015	121	Cross Pin (.437" x 1.50" hardened)	2
936002	122	Grease Fitting (Balcrank, 5000 Lincoln, 1/8-27 NPT)	2
938001	123	**Grease Relief Valve (50500, 1/8-27 NPT, Alemite 400-650 PSI)	2
977023	124	Port Plug (BSPP G1/4 hollow hex)	4
9601007	125	Jacking Screw (socket head set screw M24-3.00-070 Grade 10.9)	1
9511001	126	Jam Nut (M24-3.00 thin Grade 10.9)	1
9601010	129	Lock Ring Set Screw (M20-2.5-030, Grd 10.9)	2
949020	413	Cross-port Relief Valve Cartridge	1

**Items included in seal kit

Seal and Bearing Kits

Part Number	Item #	Description	Qty
S62110		Seal Kit (parts listed below included)	1
		Relief Valve Seal Kit	1
	107	Grease relief Valve Cover	2
	123	Grease relief Valve	2
	204	Seal	1
	205	Seal	1
	230 / 239	O-Ring	2
	231	Back-up Ring	2
	232	O-Ring	1
	233	Back-up Ring	2
	234	Seal	1
	235	Seal	1
	237	Seal	2
	238	Seal	2
62505		Bearing Kit (parts listed below included)	1
	340	Bearing	5
	342	Bearing	1
	343	Bearing	1
	344	Thrust Washer	2

Seal and Bearing kits can be ordered online at <http://www.parker.com/helac>

Serial Number Fit by Seal Kit

Part Number	Between Beginning #	And Ending #	Beginning Year Made	End Year Made	Comment
S62110	T12462	T12711	2005	2012	First two numbers after "T" designates model size.
	552259	898956	2012	2017	S/N has no relation to model size. Need to know model size.
	A42213	A92175	2018	2018	
	B5245	B25009	2018	2019	
	Also fits all TT/TTB/TBB- 12 models				

Component Identification



	<p>CAUTION</p> <p>Spraying fluids: Contents under pressure. Wear approved eye protection. Use caution when removing port plugs and fittings.</p>
---	--

	<p>CAUTION</p> <p>To avoid injury or damage to product: Secure product to work bench.</p>
---	---

<p>NOTICE</p> <p>To avoid contamination to machined parts: Make sure work area is clean.</p>

NOTICE All numbers that appear in parenthesis () in the following sections are referring to items on Page 25.

The PowerTilt is comprised of the following components:

1. Housing with integral ring gear
2. Shaft
3. Piston sleeve assembly
4. End cap
5. Lock ring
6. Standard pin-on coupler

Product Inspection

Make sure the PowerTilt is thoroughly cleaned prior to disassembly. Continue to clean all machined parts in a wash tank and dry with compressed air. Inspect the PowerTilt for corrosion prior to disassembly.

Severe corrosion can make it difficult to remove the lock ring screws (120) or set screws (129) and unthread the end cap (04). If corrosion is evident, soak the screws with penetrating oil for several hours before disassembly.

Standard Pin-on Coupler Removal

1. Begin with removing the port fittings and plugs (124) to drain the hydraulic oil into a suitable container.



2. When removing the standard pin-on coupler or torque foot (6.1) and idler foot (6.2), remove the shaft mounting screws (104).

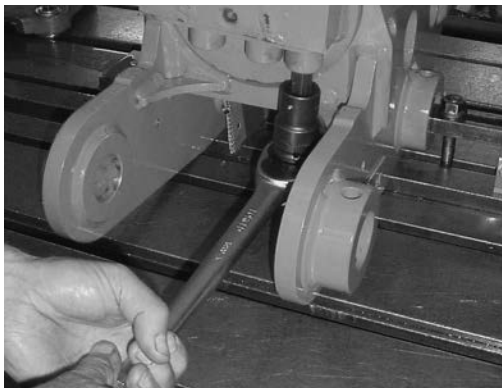

3. Secure the coupler using a hoist or similar device.



4. Unthread and remove the lock ring screws (120).



Standard Pin-on Coupler Removal

5. Tighten the two lock ring set screws (129) into the lock ring (05). Turn the set screws equally, backing the lock ring off the end cap (04) and idler foot (6.2).



7. Using a hoist or similar lifting device, lift off the standard pin-on coupler (06) or feet (6.1, 6.2).



6. Insert threaded bolts into the lock ring (05) and pull straight out.

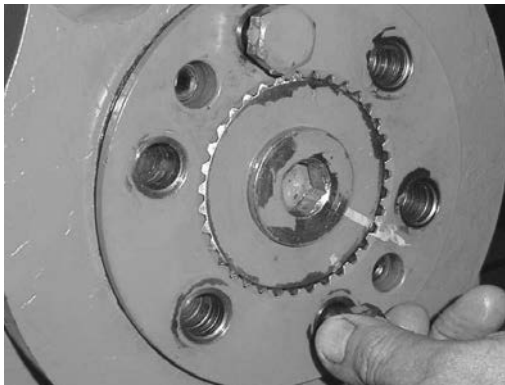

NOTICE

There is an alignment dowel pin (105) between the shaft and the torque foot (6.1) to prevent sliding.



End Cap, Lock Ring and Cross Port Relief Valve Removal

1. Unthread the port plug (101) on the end of the shaft to remove the cross port relief valve (413).
3. Unthread the end cap (04) from the shaft (02) using two bolts and a pry bar.

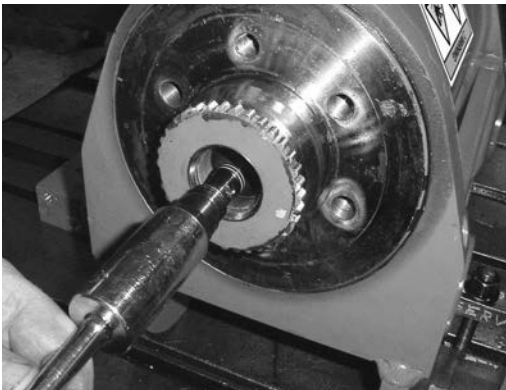

4. Remove the thrust washer (344) from the end cap (04) or the housing collar.



2. Remove the lock ring O-ring (239) from the shaft.



Shaft Removal

NOTICE

Do not remove the shaft (02) at this point. Component gearing is aligned for correct timing. Timing is critical for correct operation of the PowerTilt.

1. Rotate the shaft (02) completely clockwise, then slowly rotate the shaft counterclockwise while tapping the threaded end of the shaft to begin removing the shaft from the piston sleeve assembly (03). Stop when the shaft gearing becomes visible.



2. Locate the timing marks on the housing ring gear (1.4), piston sleeve assembly (03) and shaft (02). Small punch marks are usually found on the face of the piston teeth and ring gear. The shaft timing marks may be located in the root or "V" of the helical gearing. Piston sleeve timing marks are best seen when the splined end of the piston sleeve is flush with the ring gear inside the housing.

If you are unable to locate the factory-made timing marks, use a paint stick or a permanent marker to mark the orientation between the housing ring gear, shaft and the piston sleeve assembly.



3. Remove the shaft (02) by rotating and sliding the shaft gear teeth out of engagement with the inside diameter gear teeth of the piston sleeve assembly (03).



NOTICE

To avoid damage to gear teeth and housing bore:

Carefully support the weight of the shaft as it clears the housing.

Piston Sleeve Assembly Removal

1. Before removing the piston sleeve assembly (03), double check the timing marks of the housing ring gear (1.4) in relation to the piston sleeve assembly.

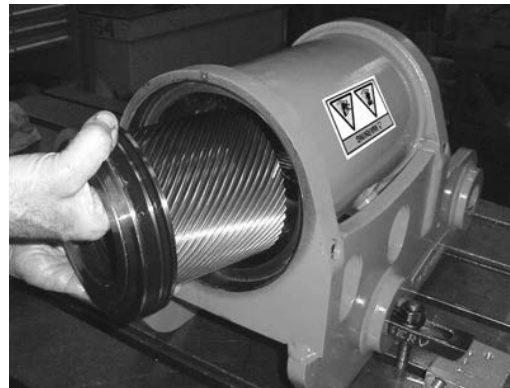
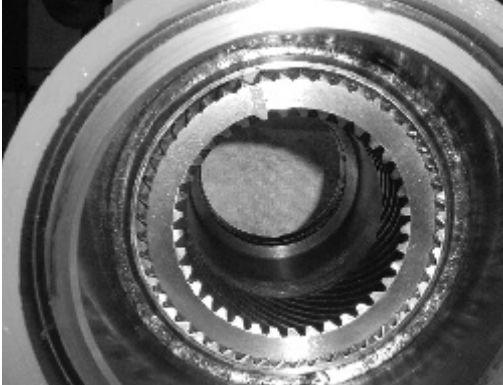

NOTICE

To avoid damage to gear teeth and housing bore:

Carefully support the weight of the piston as it clears the housing.

2. Using a rubber or plastic hammer and mandrel, gently tap the piston sleeve assembly (03) to disengage the O.D. gear teeth from the housing ring gear teeth inside the housing bore.

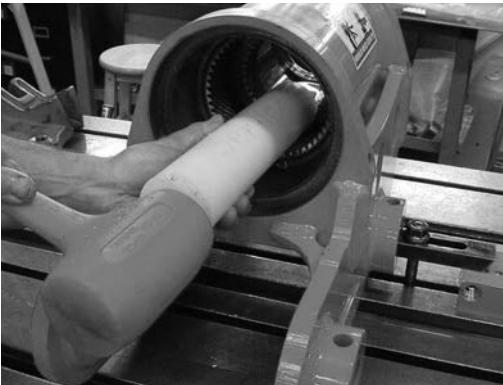

Seal and Bearing Removal

NOTICE
To avoid damage to machined parts:
Carefully remove seals using removal tools with rounded edges.

1. Use the seal tools to remove all seals, wear guides and thrust washers (344) from the piston sleeve assembly (03), end cap (04) and shaft (02).

Note that several product models may not have wear guides on the I.D. and/or O.D. of the piston sleeve assembly (03).

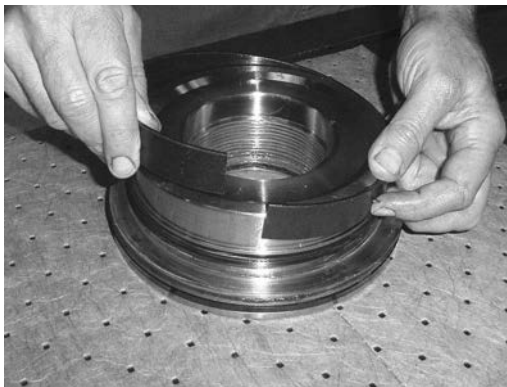

2. Remove the grease fittings (122), grease relief covers (107) and grease reliefs (123).

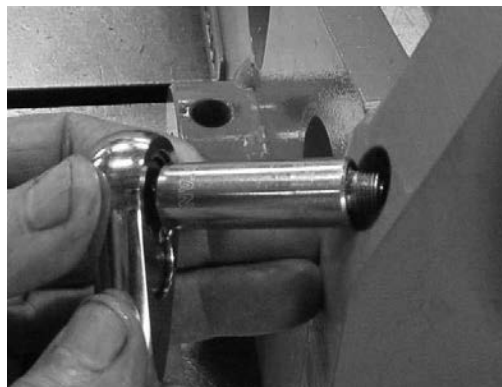

NOTICE

Replace all seals, bearings and thrust washers (344) as required.

Component and Timing Mark Inspection

1. Clean all machined components thoroughly in a wash tank and dry with compressed air.
2. Carefully inspect all critical areas: Seal grooves, wear guide grooves, thrust surfaces, shaft surfaces, housing bore and gear teeth for any wear, corrosion and any other signs of damage.
3. Locate the timing marks on the shaft (02), piston sleeve assembly (03) and housing ring gear (1.4). Re-mark with a permanent marker or paint stick if needed.

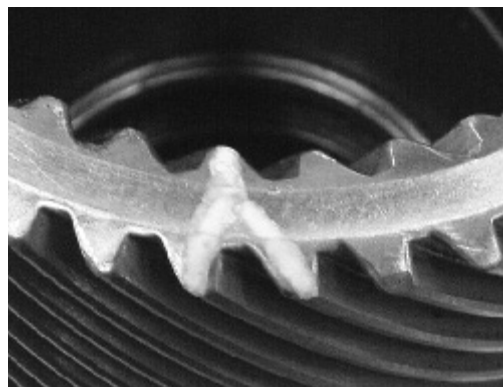
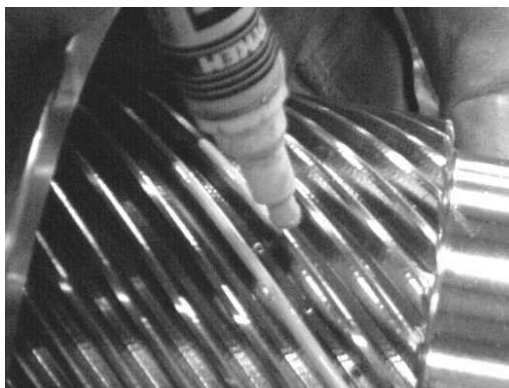
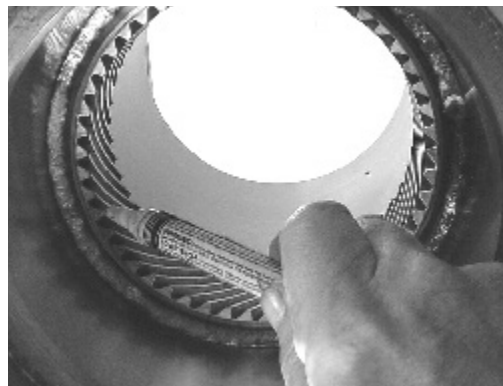

Dry Assembly

	CAUTION
	Spraying fluids: Contents under pressure. Wear approved eye protection. Use caution when removing port plugs and fittings.

	CAUTION
	To avoid injury or damage to product: Secure product to work bench.

NOTICE
To avoid contamination to machined parts:
Make sure work area is clean.

Make sure work area is clean.

In some cases, for repair personnel not familiar with the assembly process, it may be beneficial to perform a “dry” assembly. This will provide a better idea of how to properly align the gear teeth.

A “dry” assembly is typically done without seals, yet requires the wear guides and thrust washers to be installed.



Seal and Bearing Installation

Before installing seals and bearings, coat the seals and machined surfaces with a high quality hydraulic oil.



NOTICE

Replace all seals, bearings and thrust washers (344) as required.

NOTICE

The exact location and number of seals or bearings used varies by product model.

End Cap Seals and Bearing Installation

Before installing the end cap seals and bearings in the below sequence, lay the end cap (04) on the table with the inside facing up. Note orientation of all seals on assembly drawings before installing.

1. First install the O.D. exclusion seal (237).



Seal and Bearing Installation

2. Lightly coat both sides of the thrust washer (344) with lithium grease and install on the thrust face of the end cap (04).

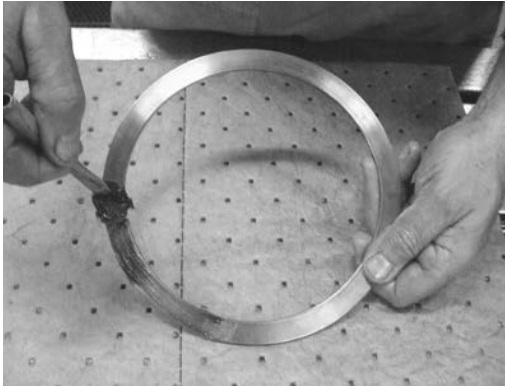

5. Now install the O-ring (230) and backup ring (231) into the I.D. seal groove on the end cap (04).



3. Next install the O.D. pressure seal (238) with the lip facing inboard toward the hydraulic pressure.

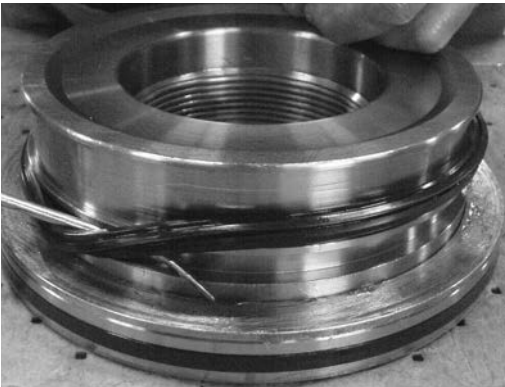

4. Then install the wear guides (340, 341) in the wide groove of the end cap (04).



Seal and Bearing Installation

Piston Seal and Bearing Installation

1. Before installing the cup seals on some PowerTilt models, remove the energizer O-ring from one O.D. and one I.D. seal and install them nearest to the piston gearing. Failure to do so may cause premature seal wear and pressure trapping.

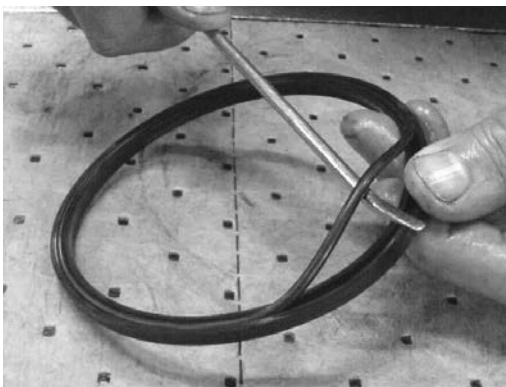

NOTICE

To avoid premature seal wear and pressure trapping on some PowerTilt models:

Remove the energizer O-ring from one I.D. and one O.D. seal nearest to the piston gearing.

2. For product models with cup and/or T-seals, install the seals on the O.D. and I.D. (234, 235) of the piston sleeve assembly. Note that the lips are facing away from each other on models with cup seals.

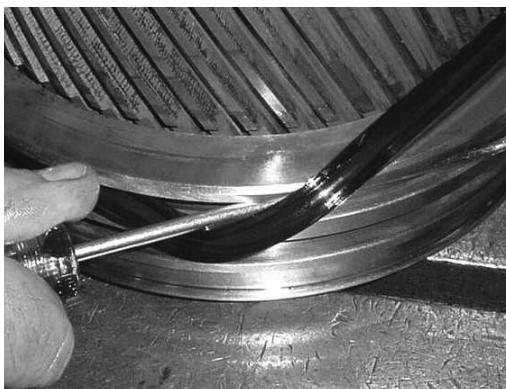

3. When used, install the wear guide(s) on the O.D. and/or I.D. (342, 343)



Seal and Bearing Installation

Shaft Seal and Bearing Installation

1. First install the exclusion seal (237) onto the shaft (02).



2. Lightly coat both sides of the thrust washer (344) with Lithium grease and install onto the shaft (02).

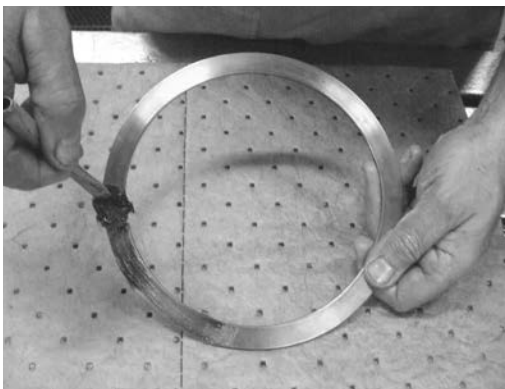

3. Then install the pressure seal (238) with the lip facing inboard, toward the hydraulic pressure.

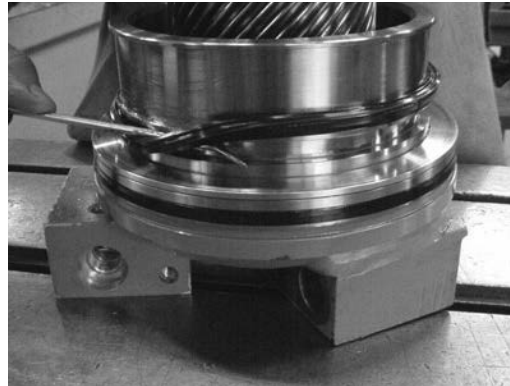

4. Now install the wear guides (340, 341).

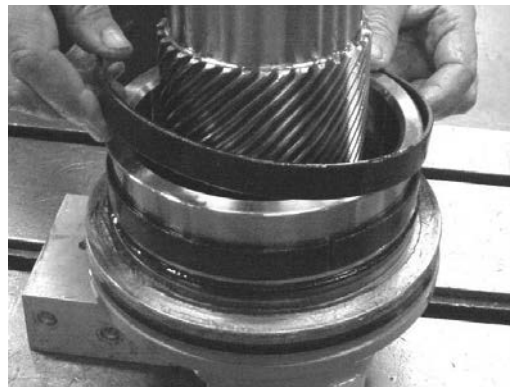

Piston Sleeve Installation

1. Before installing the piston sleeve assembly (03), coat the piston and housing bore with high quality hydraulic oil to reduce chance of seal damage.

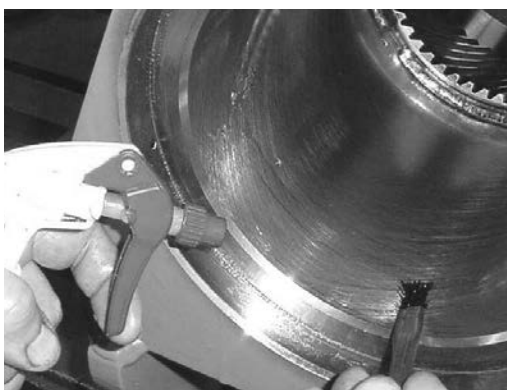

2. Carefully slide the piston sleeve assembly (03) into the housing (01). Gently tap the piston to compress the seals through the housing chamfer. Continue tapping until the piston sleeve contacts the housing ring gear (1.4).

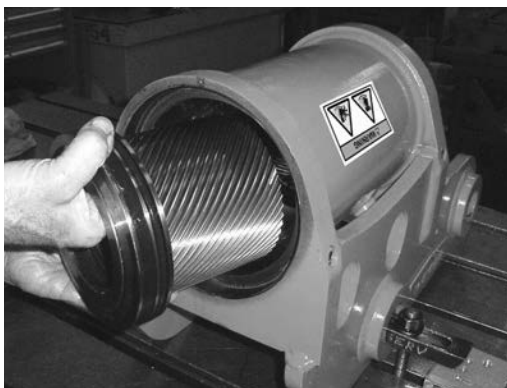

3. Confirm proper timing by aligning the piston sleeve assembly (03) timing marks with the housing ring gear (1.4) timing marks.

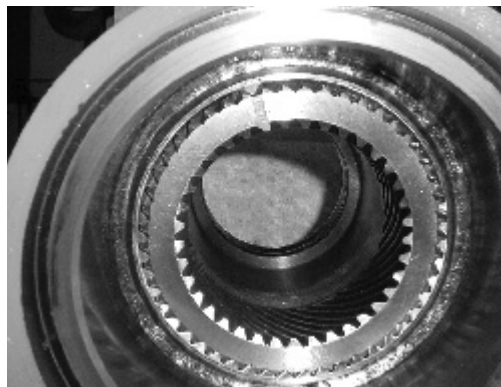

4. Then using a plastic or rubber mallet and mandrel, engage the piston sleeve (03) into the housing ring gear (1.4). Continue tapping until the piston sleeve bottoms out against the housing ring gear.

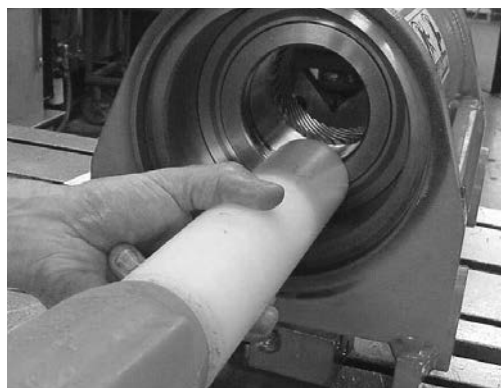

Shaft Installation

1. Before installing the shaft (02), coat the shaft with high quality hydraulic oil.

NOTICE

Temporarily cover the shaft threads with tape to prevent seal damage. Remove the tape after the shaft has been installed.

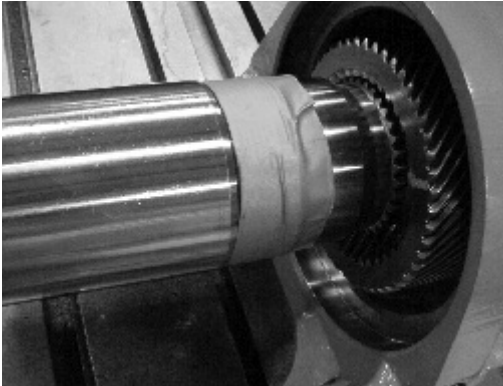

2. Insert the shaft (02) into the piston sleeve assembly (03), carefully aligning the timing marks on the shaft with the piston (03). Take care not to damage the I.D. piston seals (204, 205) with the threaded end of the shaft.

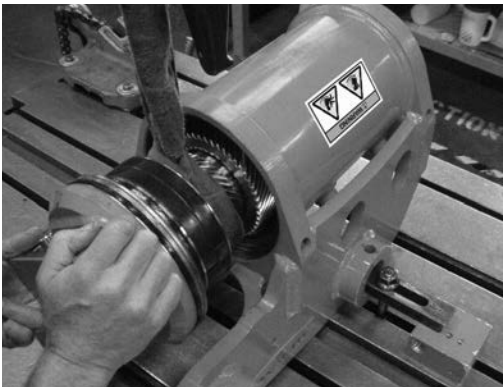

3. Verify timing marks before rotating the shaft all the way into the housing (01).



4. Use a pry bar to rotate the shaft (02) in until it is completely bottomed out in the housing (01).

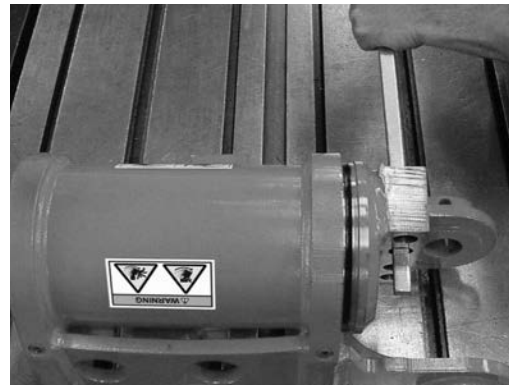

End Cap and Lock Ring Installation

1. Before installing the end cap (04), coat the end cap and shaft threads with anti-seize grease.



2. Install two screws into the end cap. Thread the end cap (04) onto the shaft (02) until the seal contacts the housing.



3. Using a pry bar, continue to rotate clockwise and tighten until the thrust washer (344) makes contact with the housing (01) collar.



4. Remove the two screws and tighten the end cap (04) using a torque wrench and customized end cap tool to the torque specifications shown on the End Cap Torque Chart on Page 41.

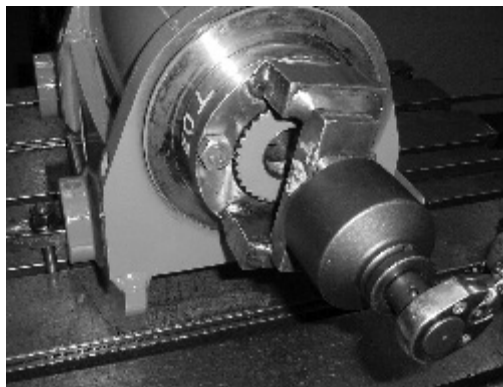

5. Then install the lock ring (05), trying different splines to find the best alignment between the lock ring splines and the end cap (04) holes. If the holes do not align, thread the end cap by no more than one spline tooth to



End Cap and Lock Ring Installation

- Now make an alignment mark between the lock ring (05) and shaft (02) splines. Then remove the lock ring.



End Cap Torque Specifications

Model	Torque (Nm)	Hydraulic Pressure (bar)
4.5	135–150	35–40
06	475–680	35–40
07	750–910	35–40
08	1360–1630	40–45
09	1770–2175	35–40
10	2210–2650	35–40
11	2780–3330	35–40
12	3500–4200	35–40

Cross Port Relief Valve Installation

- Reinstall the cross port relief valve (413) with new O-rings and back up rings and torque to 60 Nm.
- Coat the shaft port plug (101) threads with Loctite 242 and install into the end of the shaft (02) and torque to 305 Nm.

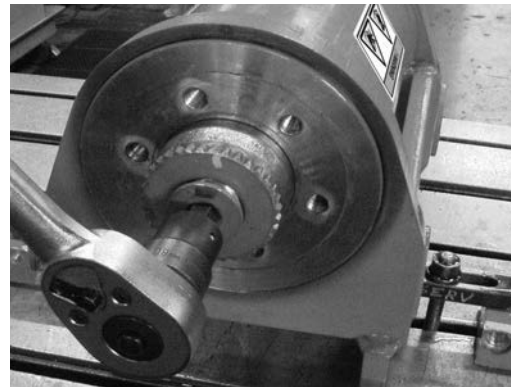
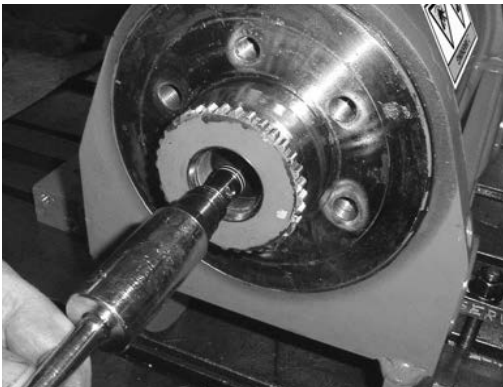

Standard Pin-on Coupler Installation

1. Reinstall the lock ring (05), aligning the timing marks. Then install and tighten two screws into the lock ring (05) to lock the end cap (04) and shaft (02) together.
2. Then using a pry bar, rotate the shaft until the torque foot (6.1) mounting surface is horizontal.

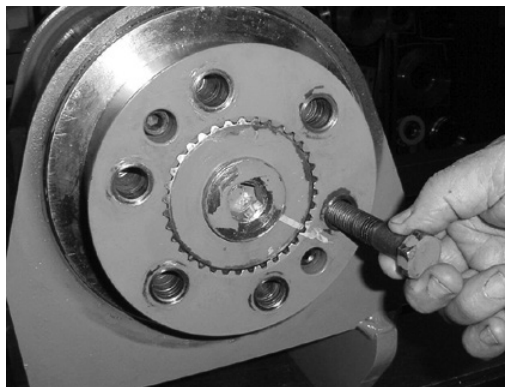
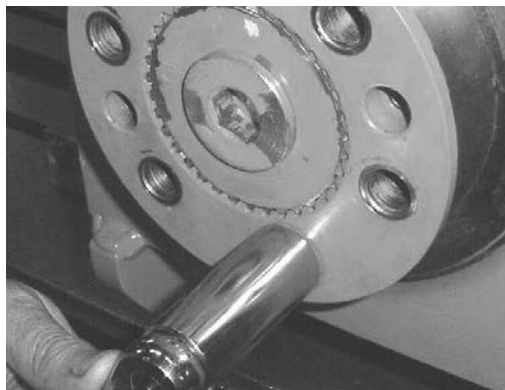
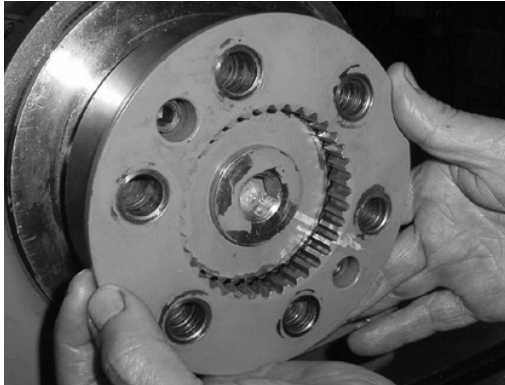

Standard Pin-on Coupler Installation

3. Remove the two screws and lock ring (05).

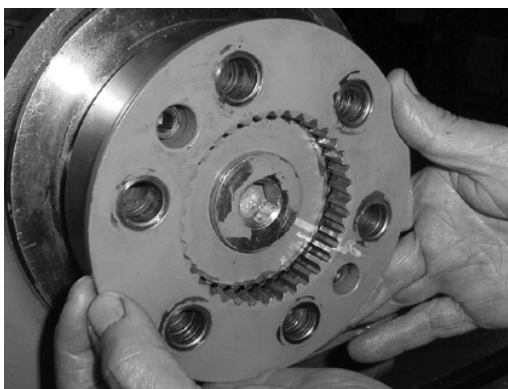

4. Install the alignment dowel pin (105) into the torque foot (6.1) if it is not already in place.



5. Then install the coupler (06) onto the shaft (02). Align the dowel pin (105) on the shaft to the torque foot (6.1).



6. Coat the end of the shaft (02), the lock ring (05) and the outside of the end cap (04) with waterproof grease.

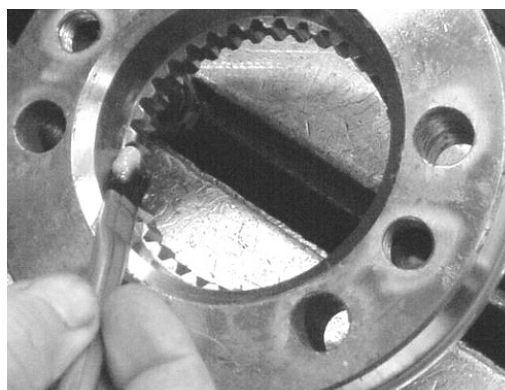

Standard Pin-on Coupler Installation

7. Install the lock ring O-ring (239) onto the shaft. 10. Coat the lock ring set screws (129) with Loctite 545, thread until tight and torque to (41 Nm).

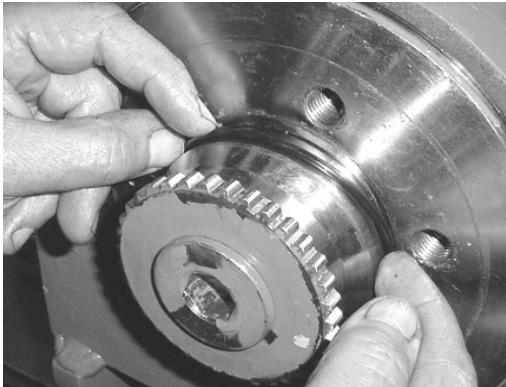

8. Next install the lock ring (05) using two threaded bolts as handles.



9. Coat the lock ring screw (120) threads with Loctite 242, install and torque per the Fastener Torque Chart on Page 42.



Standard Pin-on Coupler Installation

11. Coat the shaft mounting screw (104) threads with anti-seize grease and install.

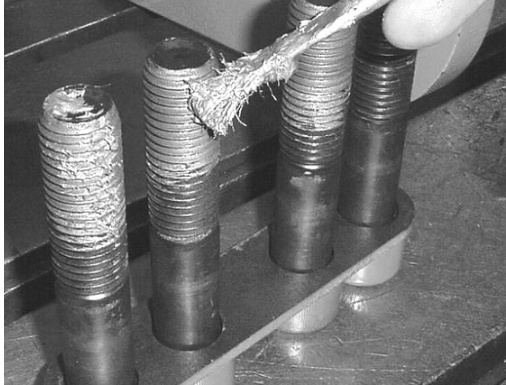

12. Torque the fasteners to the specifications shown on the Torque Specifications Charts.

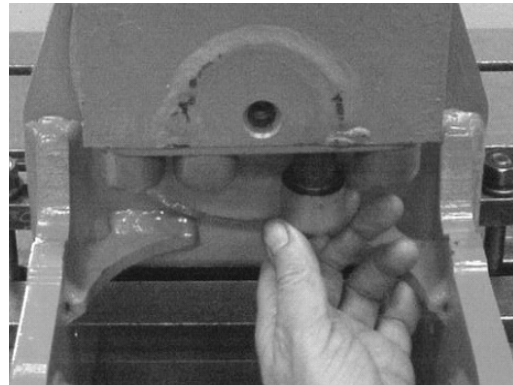

Fastener Torque Specifications

Torque Values for Port Plugs

Plug Size	Torque Value - Hollow Hex Head Plugs Nm	Torque Value – Hex Head Port Plugs Nm
BSPP G1/8	14 +/- 1	14 +/- 1
BSPP G1/4	31 +/- 1	31 +/- 1
BSPP G3/8	65 +/- 4	65 +/- 4

Torque Values for Metric Fasteners

Fastener Size	Socket Head Bolt (grd 12.9) Nm	Hex Head Bolt (grd 10.9) Nm	Jam Nut (grd 12.9) Nm
M10 x 1.50	70 +/- 3	44 +/- 3	27 +/- .2
M12 x 1.75	125 +/- 5	75 +/- 4	41 +/- .3
M16 x 2.00	310 +/- 7	187 +/- 5	54 +/- .5
M20 x 2.50	615 +/- 20	365 +/- 14	61 +/- 1
M24 x 3.00	1100 +/- 27	630 +/- 20	68 +/- 2
M30 x 3.50	2150 +/- 41	1253 +/- 34	

* All Shaft mounting screws are Grade 12.9 / All Lock Ring screws are Grade 10.9.

Testing and Greasing

	⚠ WARNING
	Pinch point hazard: Moving parts can cause serious injury. Keep hands clear during operation.

	⚠ CAUTION
	Spraying fluids: Contents under pressure. Wear approved eye protection. Use caution when removing port plugs and fittings.

	⚠ CAUTION
	To avoid injury or damage to product: Secure product to work bench.

NOTICE
To avoid contamination to machined parts:
Make sure work area is clean.

Testing the Carrier's Hydraulic System

If symptoms of poor performance develop, refer to the Troubleshooting Guide on Page 17 for general instructions. If you need help with more specific application issues, contact Helac Corporation's Service Department.

It is the responsibility of your service technician to verify that the carrier and hydraulic circuit are operating correctly. Because the PowerTilt receives its power from the carrier, a thorough check of the carrier hydraulic system is mandatory before performing any PowerTilt service or adjustments.

Testing and Greasing

Attach the PowerTilt to either a hydraulic test bench or portable pump for greasing and testing. Make sure the PowerTilt is secured to prevent movement. Install the grease fittings, grease reliefs and covers.

1. After the PowerTilt is assembled but before it is put back into service, the exclusion seals and thrust washers must be packed with Lithium grease.



2. Locate the grease fittings (122) or ports on the end of the PowerTilt and using a grease gun, pack the exclusion seal and thrust washer with grease until it exhausts from the grease reliefs (123).



3. Cycle the PowerTilt slowly and re-grease as necessary. During testing, it is recommended the PowerTilt be cycled 20 to 30 times to check for leaks and the proper degrees of rotation.

Testing and Greasing

Testing for Internal Leakage

1. Connect a 350 bar test gauge into the hydraulic line to Port P1. Pressurize until the shaft reaches the end of rotation and bottoms out externally, e.g. the shaft bracket or torque foot contacts the housing or mounting bracket.

NOTICE If the shaft is not completely bottomed out, hydraulic fluid will exhaust from Port P2 at a high velocity.

2. Remove and cap the hydraulic line to Port P2. Pressurize Port P1 to 175 bar. Check for leakage at Port P2 and from around the main shaft and end cap seals. Leaks indicate improperly installed parts.
3. Reconnect the hydraulic line to Port P2 and pressurize as in Step 1 above.
4. Check for leaks at Port P1 and around the main shaft and end cap seals as in Step 2 above.

Testing the Cross Port Relief Valve

The integral cross port relief valve vents hydraulic oil around the internal piston assembly of the PowerTilt at approximately 210 to 238 bar.

To test the valve:

1. Connect a 350 bar test gauge into the line to Port P1. Pressurize until the shaft reaches the end of rotation and bottoms out externally, e.g. the shaft bracket or torque foot contacts the housing or mounting bracket.
2. Relieve pressure to P2 and disconnect the hydraulic hose and cap it.
3. Install a temporary hydraulic hose to P2 with the end of the hose vented to an appropriate container.

NOTICE The cross port relief valve is set at the factory and cannot be adjusted.

4. Slowly pressurize Port P1 noting the pressure at which oil flows from P2. The relief should vent at approximately 210 to 238 bar.
5. Test at Port P2 using the same procedure.
6. If test pressure does not meet specification, the valve must be replaced. If piston seal leakage is suspected, relief port test plugs are available from the factory.

Offer of Sale

The items described in this document and other documents and descriptions provided by Parker Hannifin Corporation, its subsidiaries and its authorized distributors ("Seller") are hereby offered for sale at prices to be established by Seller. This offer and its acceptance by any customer ("Buyer") shall be governed by all of the following Terms and Conditions. Buyer's order for any item described in this document, when communicated to Seller verbally, or in writing, shall constitute acceptance of this offer. All goods, services or work described will be referred to as "Products".

1. Terms. All sales of Products by Seller will be governed by, and are expressly conditioned upon Buyer's assent to, these Terms. These Terms are incorporated into any Quote provided by Seller to Buyer. Buyer's order for any Products whether communicated to Seller verbally, in writing, by electronic data interchange or other electronic commerce, shall constitute acceptance of these Terms. Seller objects to any contrary or additional terms or conditions of Buyer. Reference in Seller's order acknowledgement to Buyer's purchase order or purchase order number shall in no way constitute an acceptance of any of Buyer's terms or conditions of purchase. Any Quote made by Seller to Buyer shall be considered a firm and definite offer and shall not be deemed to be otherwise despite any language on the face of the Quote. Seller reserves all rights to accept or reject any purported acceptance by Buyer to Seller's Quote if such purported acceptance attempts to vary the terms of the Quote. If Seller ships Products after Buyer issues an acceptance to the Quote, any additional or different terms proposed by Buyer will not become part of the parties' business relationship unless agreed to in a writing that is signed by an authorized representative of Seller, excluding email correspondence. If the transaction proceeds without such agreement on the part of Seller, the business relationship will be governed solely by these Terms and the specific terms in Seller's Quote.

2. Price; Payment. The Products set forth in the Quote are offered for sale at the prices indicated in the Quote. Unless otherwise specifically stated in the Quote, prices are valid for thirty (30) days and do not include any sales, use, or other taxes or duties. Seller reserves the right to modify prices for any reason and at any time by giving ten (10) days prior written notice. Unless otherwise specified by Seller, all prices are F.C.A. Seller's facility (INCOTERMS 2020). All sales are contingent upon credit approval and full payment for all purchases is due thirty (30) days from the date of invoice (or such date as may be specified in the Quote). Under any circumstances, Buyer may not withhold or suspend payment of any amounts due and payable as a deduction, set-off or recoupment of any amount, claim or dispute with Seller. Unpaid invoices beyond the specified payment date incur interest at the rate of 1.5% per month or the maximum allowable rate under applicable law. Seller reserves the right to require advance payment or provision of securities for first and subsequent deliveries if there is any doubt, in Seller's sole determination, regarding the Buyer's creditworthiness or for other business reasons. If the requested advance payment or securities are not provided to Seller's satisfaction, Seller reserves the right to suspend performance or reject the purchase order, in whole or in part, without prejudice to Seller's other rights or remedies, including the right to full compensation. Seller may revoke or shorten any payment periods previously granted in Seller's sole determination. The rights and remedies herein reserved to Seller are cumulative and in addition to any other or further rights and remedies available at law or in equity. No waiver by Seller of any breach by Buyer of any provision of these terms will constitute a waiver by Seller of any other breach of such provision.

3. Shipment; Delivery; Title and Risk of Loss. All delivery dates are approximate, and Seller is not responsible for damages or additional costs resulting from any delay. All deliveries are subject to our ability to procure materials from our suppliers. Regardless of the manner of shipment, delivery occurs and title and risk of loss or damage pass to Buyer, upon placement of the Products with the carrier at Seller's facility. Unless otherwise agreed prior to shipment and for domestic delivery locations only, Seller will select and arrange, at Buyer's sole expense, the carrier and means of delivery. When Seller selects and arranges the carrier and means of delivery, freight and insurance costs for shipment to the designated delivery location will be prepaid by Seller and added as a separate line item to the invoice. Buyer shall be responsible for any additional shipping charges incurred by Seller due to Buyer's acts or omissions. Buyer shall not return or repack any Products without the prior written authorization from Seller, and any return shall be at the sole cost and expense of Buyer.

4. Warranty. The warranty for the Products is as follows: (i) Goods are warranted against defects in material or workmanship for a period of eighteen (18) months from the date of delivery or 2,000 hours of use, whichever occurs first; (ii) Services shall be performed in accordance with generally accepted practices and using the degree of care and skill that is ordinarily exercised and customary in the field to which the Services pertain and are warranted for a period of six (6) months from the date of completion of the Services; and (iii) Software is only warranted to perform in accordance with applicable specifications provided by Seller to Buyer for ninety (90) days from the date of delivery or, when downloaded by a Buyer or end-user, from the date of the initial download. All prices are based upon the exclusive limited warranty stated above, and upon the following disclaimer: **EXEMPTION CLAUSE; DISCLAIMER OF WARRANTY, CONDITIONS, REPRESENTATIONS: THIS WARRANTY IS THE SOLE AND ENTIRE WARRANTY, CONDITION, AND REPRESENTATION, PERTAINING TO PRODUCTS. SELLER DISCLAIMS ALL OTHER WARRANTIES, CONDITIONS, AND REPRESENTATIONS, WHETHER STATUTORY, EXPRESS OR IMPLIED, INCLUDING BUT NOT LIMITED TO THOSE RELATING TO DESIGN, NON-INFRINGEMENT, MERCHANTABILITY, AND FITNESS FOR A PARTICULAR PURPOSE. SELLER DOES NOT WARRANT THAT THE SOFTWARE IS ERROR-FREE OR FAULT-TOLERANT, OR THAT BUYER'S USE THEREOF WILL BE SECURE OR UNINTERRUPTED, UNLESS OTHERWISE AUTHORIZED IN WRITING BY SELLER, THE SOFTWARE SHALL NOT BE USED IN CONNECTION WITH HAZARDOUS OR HIGH-RISK ACTIVITIES OR ENVIRONMENTS. EXCEPT AS EXPRESSLY STATED HEREIN, ALL PRODUCTS ARE PROVIDED "AS IS".**

5. Claims; Commencement of Actions. Buyer shall promptly inspect all Products upon receipt. No claims for shortages will be allowed unless reported to Seller within ten (10) days of delivery. Buyer shall notify Seller of any alleged breach of warranty within thirty (30) days after the date the non-conformance is or should have been discovered by Buyer. Any claim or action against Seller based upon breach of contract or any other theory, including tort, negligence, or otherwise must be commenced within twelve (12) months from the date of the alleged breach or other alleged event, without regard to the date of discovery.

6. LIMITATION OF LIABILITY. IN THE EVENT OF A BREACH OF WARRANTY, SELLER WILL, AT ITS OPTION, REPAIR OR REPLACE THE NON-CONFORMING PRODUCTS, RE-PERFORM THE SERVICES, OR REFUND THE PURCHASE PRICE PAID WITHIN A REASONABLE PERIOD OF TIME. IN NO EVENT IS SELLER LIABLE FOR ANY SPECIAL, INDIRECT, INCIDENTAL OR CONSEQUENTIAL DAMAGES INCLUDING ANY LOSS OF REVENUE OR PROFITS, WHETHER BASED IN CONTRACT, TORT OR OTHER LEGAL THEORY. IN NO EVENT SHALL SELLER'S LIABILITY UNDER ANY CLAIM MADE BY BUYER EXCEED THE PURCHASE PRICE PAID FOR THE PRODUCTS.

7. Confidential Information. Buyer acknowledges and agrees that Confidential Information has been and will be received in confidence and will remain the property of Seller. Buyer further agrees that it will not use Seller's Confidential Information for any purpose other than for the benefit of Seller and shall return all such Confidential Information to Seller within thirty (30) days upon request.

8. Loss to Buyer's Property. Buyer's Property will be considered obsolete and may be destroyed by Seller after two (2) consecutive years have elapsed without Buyer ordering the Products manufactured using Buyer's Property. Also, Seller shall not be responsible for any loss or damage to Buyer's Property while it is in Seller's possession or control.

9. Special Tooling. Seller may impose a tooling charge for any Special Tooling. Special Tooling shall be and remain Seller's property. In no event will Buyer acquire any interest in the Special Tooling, even if such Special Tooling has been specially converted or adapted for manufacture of Goods for Buyer and notwithstanding any charges paid by Buyer. Unless otherwise agreed, Seller has the right to alter, discard or otherwise dispose of any Special Tooling or other property owned by Seller in its sole determination at any time.

10. Security Interest. To secure payment of all sums due from Buyer, Seller retains a security interest in all Products delivered to Buyer and, Buyer's acceptance of these Terms is deemed to be a Security Agreement under the Uniform Commercial Code. Buyer authorizes Seller as its attorney to execute and file on Buyer's behalf all documents Seller deems necessary to perfect Seller's security interest.

11. User Responsibility. Buyer, through its own analysis and testing, is solely responsible for making the final selection of the Products and assuring that all performance, endurance, maintenance, safety and warning requirements of the application of the Products are met. Buyer must analyze all aspects of the application and follow applicable industry standards, specifications, and any technical information provided with the Quote or the Products, such as Seller's instructions, guides and specifications. If Seller provides options of or for Products based upon data or specifications provided by Buyer, Buyer is responsible for determining that such data and specifications are suitable and sufficient for all applications and reasonably foreseeable uses of the Products. In the event Buyer is not the end-user of the Products, Buyer will ensure such end-user complies with this paragraph.

12. Use of Products, Indemnity by Buyer. Buyer shall comply with all instructions, guides and specifications provided by Seller with the Quote or the Products. If Buyer uses or resells the Products in any way prohibited by Seller's instructions, guides or specifications, or Buyer otherwise fails to comply with Seller's instructions, guides and specifications, Buyer acknowledges that any such use, resale, or non-compliance is at Buyer's sole risk. Further, Buyer shall indemnify, defend, and hold Seller harmless from any losses, claims, liabilities, damages, lawsuits, judgments and costs (including attorney fees and defense costs), whether for personal

PowerTilt Tilting Coupler PowerTilt Series Service & Repair Manual

injury, property damage, intellectual property infringement or any other claim, arising out of or in connection with: (a) improper selection, design, specification, application, or any misuse of Products; (b) any act or omission, negligent or otherwise, of Buyer; (c) Seller's use of Buyer's Property; (d) damage to the Products from an external cause, repair or attempted repair by anyone other than Seller, failure to follow instructions, guides and specifications provided by Seller, use with goods not provided by Seller, or opening, modifying, deconstructing, tampering with or repackaging the Products; or (e) Buyer's failure to comply with these Terms, including any legal or administrative proceedings, collection efforts, or other actions arising from or relating to such failure to comply. Seller shall not indemnify Buyer under any circumstance except as otherwise provided in these Terms.

13. Cancellations and Changes. Buyer may not cancel or modify, including but not limited to movement of delivery dates for the Products, any order for any reason except with Seller's written consent and upon terms that will indemnify, defend and hold Seller harmless against all direct, incidental and consequential loss or damage and any additional expense. Seller, at any time, may change features, specifications, designs and availability of Products.

14. Assignment. Buyer may not assign its rights or obligations without the prior written consent of Seller.

15. Force Majeure. Seller is not liable for delay or failure to perform any of its obligations by reason of any events or circumstances beyond its reasonable control. Such circumstances include without limitation: accidents, labor disputes or stoppages, government acts or orders, acts of nature, pandemics, epidemics, other widespread illness, or public health emergency, cyber related disruptions, cyber-attacks, ransomware sabotage, delays or failures in delivery from carriers or suppliers, shortages of materials, sudden increases in the price of raw material or components, shutdowns or slowdowns affecting the supply of raw materials or components, or the transportation thereof, oil shortages or oil price increases, energy crisis, energy or fuel interruption, war (whether declared or not) or the serious threat of same, riots, rebellions, acts of terrorism, embargoes, fire or any reason whether similar to the foregoing or otherwise. Seller will resume performance as soon as practicable after the event of force majeure has been removed. All delivery dates affected by an event of force majeure shall be tolled for the duration of such event of force majeure and rescheduled for mutually agreed dates as soon as practicable after the event of force majeure ceases to exist. The right to allocate capacity is in the Seller's sole discretion. An event of force majeure shall not include financial distress, insolvency, bankruptcy, or other similar conditions affecting one of the parties, affiliates and/or sub-contractors. An event of force majeure in the meaning of these Terms means any circumstances beyond Seller's control that temporarily or permanently hinders performance, even where that circumstance was already foreseen. Buyer shall not be entitled to cancel any orders following its claim of an event of force majeure.

16. Waiver and Severability. Failure to enforce any provision of these Terms will not invalidate that provision; nor will any such failure prejudice either party's right to enforce that provision in the future. Invalidation of any provision of these Terms shall not invalidate any other provision herein and, the remaining provisions will remain in full force and effect.

17. Duration. Unless otherwise stated in the Quote, any agreement governed by or arising from these Terms shall: (a) be for an initial duration of one (1) year; and (b) shall automatically renew for successive one-year terms unless terminated by Buyer with at least 180-days written notice to Seller or if Seller terminates the agreement pursuant to Section 19 of these Terms.

18. Termination. Seller may, without liability to Buyer, terminate any agreement governed by or arising from these Terms for any reason and at any time by giving Buyer thirty (30) days prior written notice. Seller may immediately terminate, in writing, if Buyer: (a) breaches any provision of these Terms, (b) becomes or is deemed insolvent, (c) appoints or has appointed a trustee, receiver or custodian for all or any part of Buyer's property, (d) files a petition for relief in bankruptcy on its own behalf, or one is filed against Buyer by a third party, (e) makes an assignment for the benefit of creditors, or (f) dissolves its business or liquidates all or a majority of its assets.

19. Ownership of Rights. Buyer agrees that (a) Seller (and/or its affiliates) owns or is the valid licensee of Seller's IP and (b) the furnishing of information, related documents or other materials by Seller to Buyer does not grant or transfer any ownership interest or license in or to Seller's IP to Buyer, unless expressly agreed in writing. Without limiting the foregoing, Seller retains ownership of all Software supplied to Buyer. In no event shall Buyer obtain any greater right in and to the Software than a right in a license limited to the use thereof and subject to compliance with any other terms provided with the Software. Buyer further agrees that it will not, directly or through intermediaries, reverse engineer, decompile, or disassemble any Software (including firmware) comprising or contained within a Product, except and only to the extent that such activity may be expressly permitted, either by applicable law or, in the case of open source software, the applicable open source license.

20. Indemnity for Infringement of Intellectual Property Rights. Seller is not liable for infringement of any Intellectual Property Rights except as provided in this Section. Seller will defend at its expense and will pay the cost of any settlement or damages awarded in an action brought against Buyer based on a third-party claim that one or more of the Products infringes the Intellectual Property Rights of a third party in the country of delivery of the Products by Seller to Buyer. Seller's obligation to defend and indemnify Buyer is contingent on Buyer notifying Seller within ten (10) days after Buyer becomes aware of any such claim, and Seller having sole control over the defense of the claim including all negotiations for settlement or compromise. If one or more Products is subject to such a claim, Seller may, at its sole expense and option, procure for Buyer the right to continue using the Products, replace or modify the Products to render them non-infringing, or offer to accept return of the Products and refund the purchase price less a reasonable allowance for depreciation. Seller has no obligation or liability for any claim of infringement: (i) arising from information provided by Buyer (including Seller's use of Buyer's Property); or (ii) directed to any Products for which the designs are specified in whole or part by Buyer; or (iii) resulting from the modification, combination or use in a system of any Products. The foregoing provisions of this Section constitute Seller's sole and exclusive liability and Buyer's sole and exclusive remedy for claims of infringement of Intellectual Property Rights.

21. Governing Law. These Terms, the terms of any Quote, and the sale and delivery of all Products are deemed to have taken place in, and shall be governed and construed in accordance with, the laws of the State of Ohio, as applicable to contracts executed and wholly performed therein and without regard to conflicts of laws principles. Buyer irrevocably agrees and consents to the exclusive jurisdiction and venue of the courts of Cuyahoga County, Ohio with respect to any dispute, controversy or claim arising out of or relating to the sale and delivery of the Products.

22. Entire Agreement. These Terms, along with the terms set forth in the Quote, forms the entire agreement between the Buyer and Seller and constitutes the final, complete and exclusive expression of the terms of sale and purchase. In the event of a conflict between any term set forth in the Quote and these Terms, the terms set forth in the Quote shall prevail. All prior or contemporaneous written or oral agreements or negotiations with respect to the subject matter shall have no effect. No modification to these Terms will be binding on Seller unless agreed to in a writing that is signed by an authorized representative of Seller, excluding email correspondence, "clickwrap" or other purported electronic assent to different or additional terms. Sections 2-25 of these Terms shall survive termination or cancellation of any agreement governed by or arising from these Terms.

23. No "Wrap" Agreements/No Authority to Bind. Seller's clicking any buttons or any similar action, such as clicking "I Agree" or "Confirm," to utilize Buyer's software or webpage for the placement of orders, is NOT an agreement to Buyer's Terms and Conditions. NO EMPLOYEE, AGENT OR REPRESENTATIVE OF SELLER HAS THE AUTHORITY TO BIND SELLER BY THE ACT OF CLICKING ANY BUTTON OR SIMILAR ACTION ON BUYER'S WEBSITE OR PORTAL.

24. Compliance with Laws. Buyer agrees to comply with all applicable laws, regulations, and industry and professional standards, including those of the United States of America, and the country or countries in which Buyer may operate, including without limitation the U.S. Foreign Corrupt Practices Act ("FCPA"), the U.S. Anti-Kickback Act ("Anti-Kickback Act"), U.S. and E.U. export control and sanctions laws ("Export Laws"), the U.S. Food Drug and Cosmetic Act ("FDCA"), and the rules and regulations promulgated by the U.S. Food and Drug Administration ("FDA"), each as currently amended. Buyer agrees to indemnify, defend, and hold harmless Seller from the consequences of any violation of such laws, regulations and standards by Buyer, its employees or agents. Buyer represents that it is familiar with all applicable provisions of the FCPA, the Anti-Kickback Act, Export Laws, the FDCA and the FDA and certifies that Buyer will adhere to the requirements thereof and not take any action that would make Seller violate such requirements. Buyer represents and agrees that Buyer will not make any payment or give anything of value, directly or indirectly, to any governmental official, foreign political party or official thereof, candidate for foreign political office, or commercial entity or person, for any improper purpose, including the purpose of influencing such person to purchase Products or otherwise benefit the business of Seller. Buyer further represents and agrees that it will not receive, use, service, transfer or ship any Products from Seller in a manner or for a purpose that violates Export Laws or would cause Seller to be in violation of Export Laws. Buyer agrees to promptly and reliably provide Seller all requested information or documents, including end-user statements and other written assurances, concerning Buyer's ongoing compliance with Export Law. (9/22)

Notes

Notes

Notes

Parker Hannifin Corporation
Cylinder and Accumulator Division
225 Battersby Avenue
Enumclaw, WA 98022 USA
phone (360) 825-1601
fax (360) 825-1603
www.parker.com/helac

