

Value Propositions

VA450

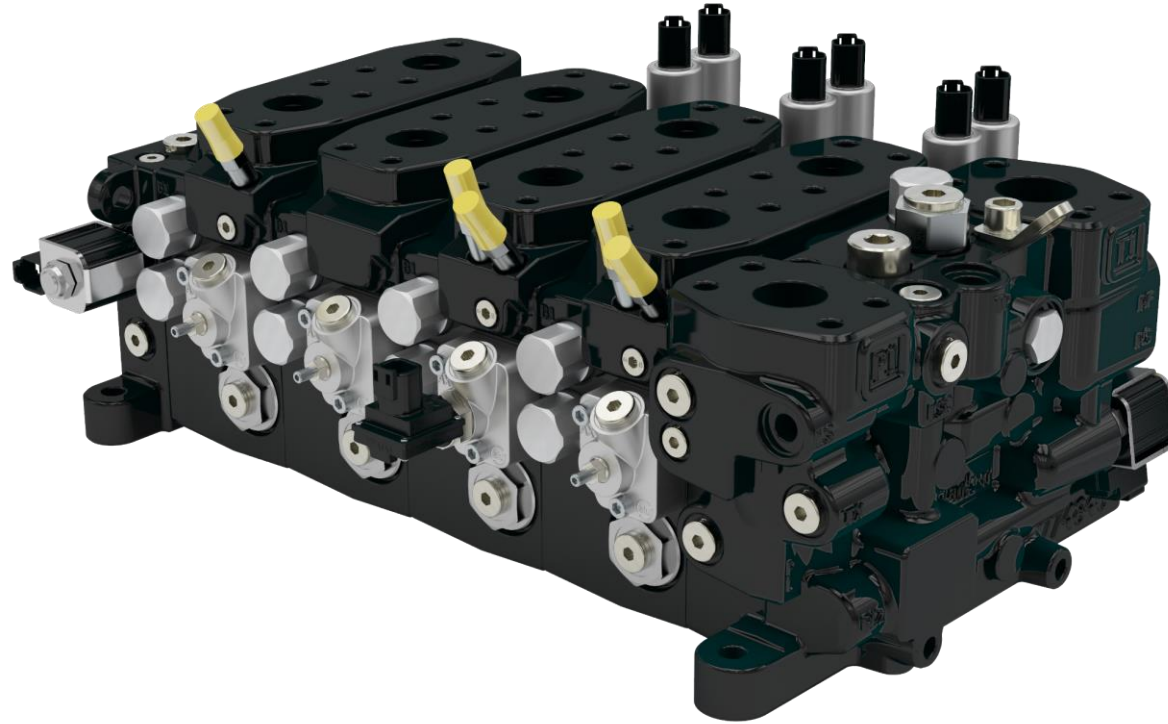

Leading with
Purpose

August 21, 2024

ENGINEERING YOUR SUCCESS.

Market type – Value Propositions

Forestry

Product

VA450

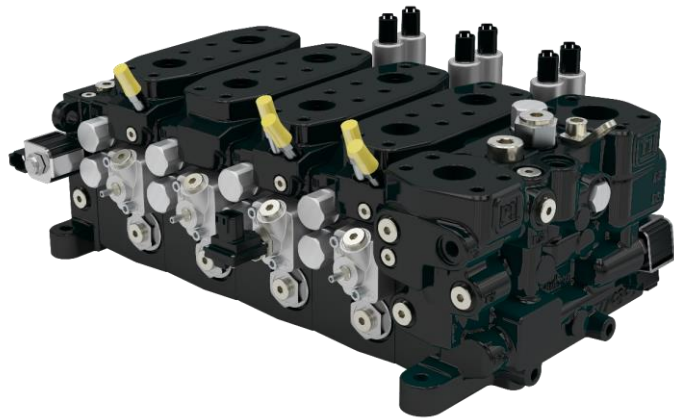

VA450 is characterized by industry leading properties regarding robustness, control precision and energy efficiency

Market & Applications



Forestry

- Harvesters
- Forwarders
- Harvesting heads
- Forest truck cranes

Value Propositions

- Precise movement control for single and simultaneous operated functions
- High productivity and energy efficiency
- Robust – built to last in tough environments
- Function adapted manifolds
- Modern platform to suit future needs of high productivity & reliability



Market type – Value Propositions

Construction

Product

VA450



VA450 is characterized by industry leading properties regarding robustness, control precision and energy efficiency

Market & Applications



Construction

- High end backhoes & Multi purpose machines
- Wheel loaders

Value Propositions

- Precise movement control for single and simultaneous operated functions
- High productivity and energy efficiency
- Robust – built to last in tough environments
- Function adapted manifolds
- Modern platform to suit future needs of high productivity & reliability



Market type – Value Propositions

Mining

Product

VA450



VA450 is characterized by industry leading properties regarding robustness, control precision and energy efficiency

Market & Applications



Mining

- Drill rigs
- Mine loaders
- Demolition machines

Value Propositions

- Precise movement control for single and simultaneous operated functions
- High productivity and energy efficiency
- Robust – built to last in tough environments
- Function adapted manifolds
- Modern platform to suit future needs of high productivity & reliability



Market type – Value Propositions

Material handling

Product

VA450

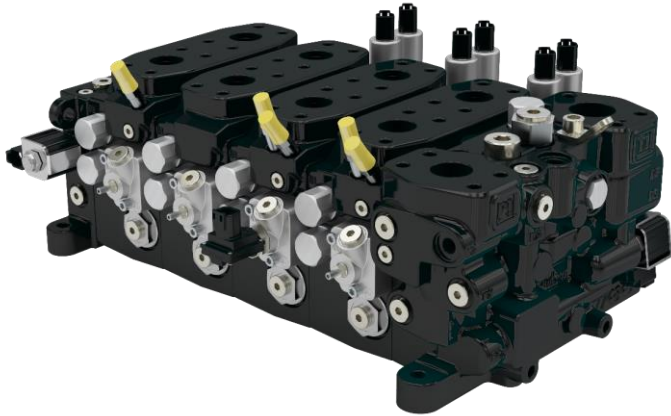

VA450 is characterized by industry leading properties regarding robustness, control precision and energy efficiency

Market & Applications



Material handling

- Cranes
- Forklifts
- Reach stackers

Value Propositions

- Precise movement control for single and simultaneous operated functions
- High productivity and energy efficiency
- Robust – built to last in tough environments
- Function adapted manifolds
- Modern platform to suit future needs of high productivity & reliability



Key Attributes

VA450

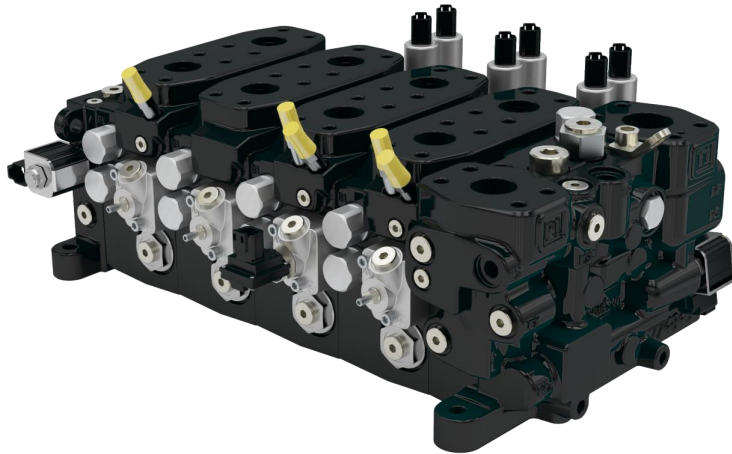

- Maximum operating pressure 380 bar
- Flow rate from workport 450 l/min at ΔP (P-LS) 20 bar
- Proportional spool actuators electric and hydraulic
- Function adapted spools
- Pre-compensated valve with possibility of flow sharing function
- Spool position and workport pressure sensors used for diagnostics
- Oil circulation circuit
- Float function in end section
- Individual workport pressure LS limiters
- Electric proportional workport pressure LS limiter
- Port relief valves with good precision
- Low internal leakage from pump to tank
- Designed for high duty applications, long fatigue life
- Service and installation friendly
- Function-adapted manifolds to meet specific requirements