

VA Series VA450

Next generation Load Sensing valves

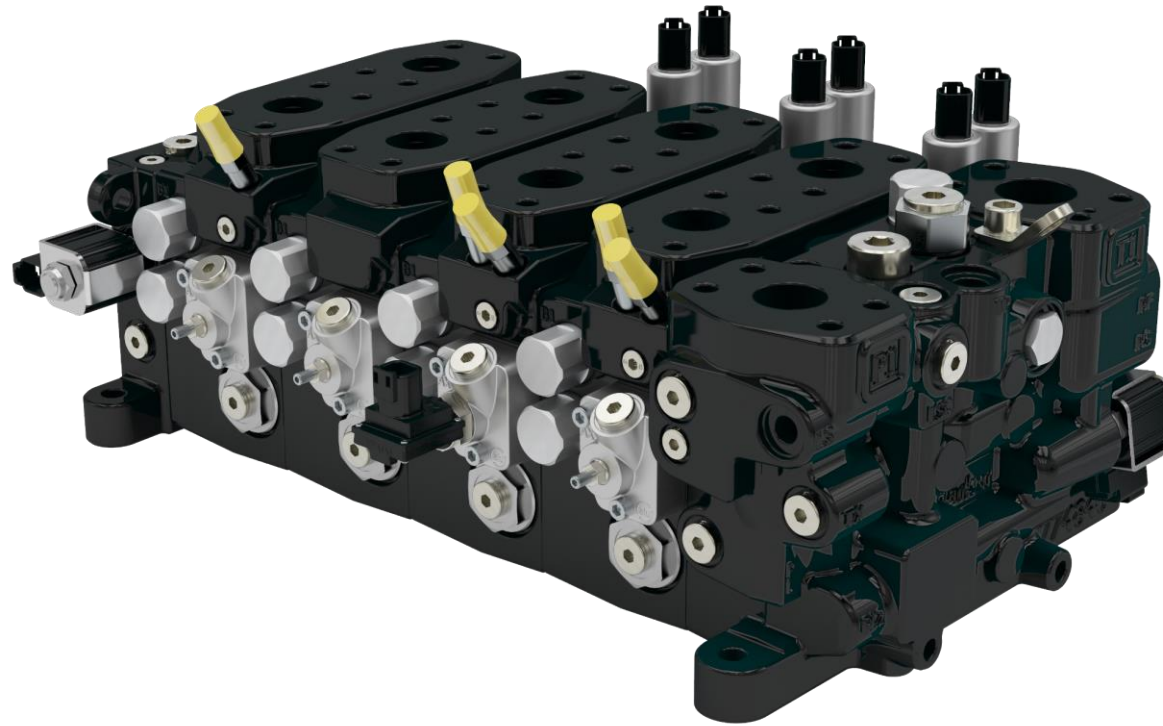

Leading with
Purpose

August 21, 2024

ENGINEERING YOUR SUCCESS.

VA Series

Next Generation Pre-Compensated Load Sensing Valves

- Robustness
- Modernized platform
- Increased flow range
- Efficient valve combinations
- Energy efficiency
- Productivity
- Controllability
- Connectivity
- Software options
- Serviceability

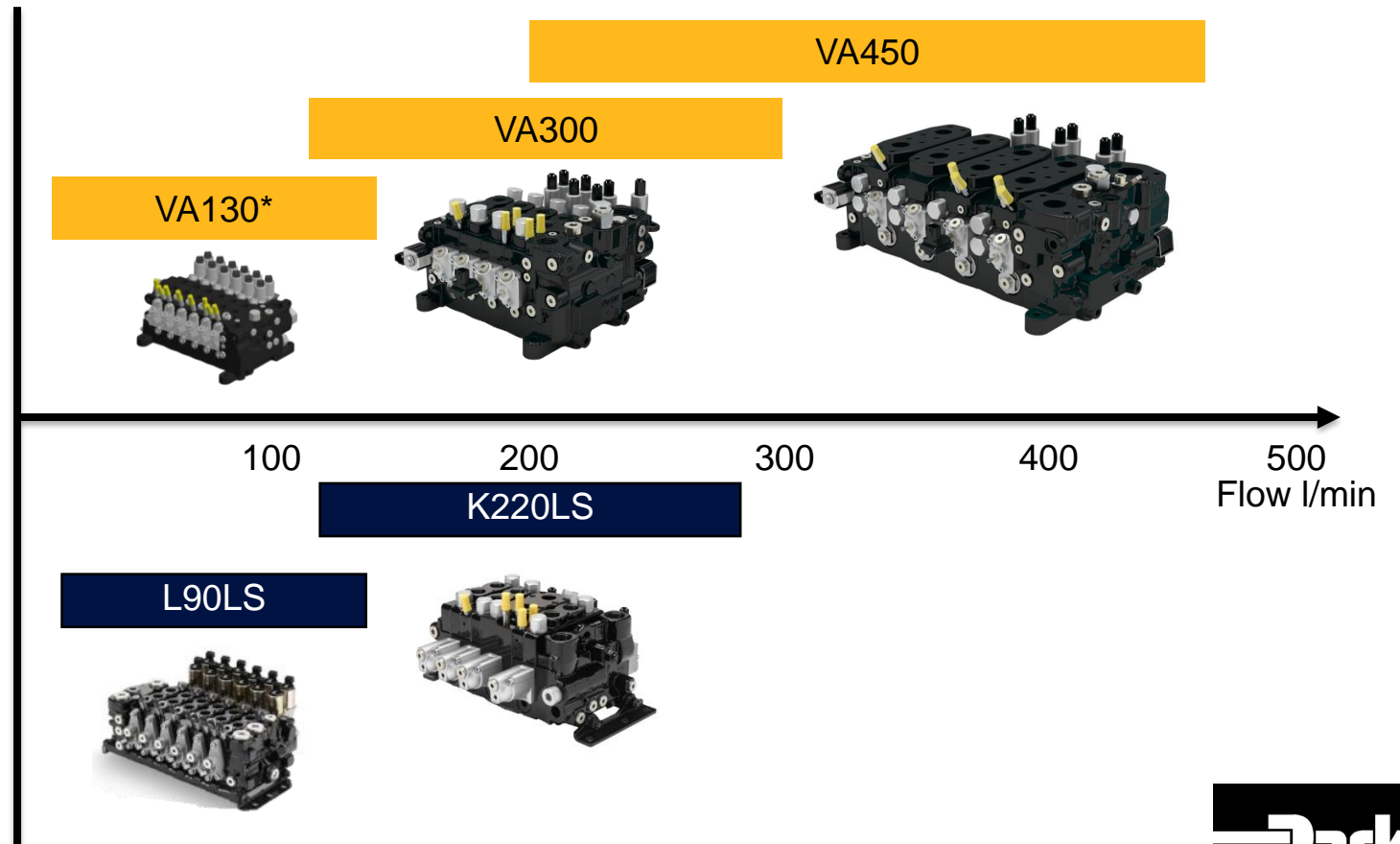

*Under development



VA Series

Functionality and Modularity

“Flexible combination possibilities enables adding new technology in your own pace”.

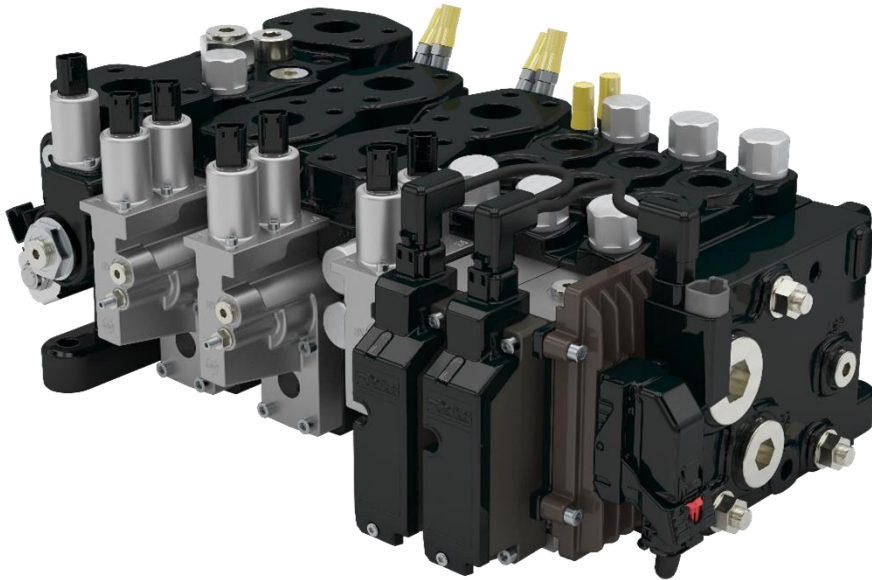

- VA Series valves can be combined
- Well-known hydraulic function
Based on K220LS and L90LS experience
- New hydraulic functions
Counter pressure with active refill, Electric proportional feed reducer, Pilot blocking, Oil circulation, Float function etc.
- Diagnostics
Workport pressure sensors, Spool position sensors
- CAN spool actuator
Integrated Workport pressure-, Spool position, Temperature sensors & Pilot valves
- Software functions with CAN actuator VC1/VCM1
- Customer adaptation

VA Series

Customer Values

Robustness

Zero Defects

Proven technology

Built to last



Energy Efficiency & Productivity

Optimized design

New options and technology

Integration of Electronics

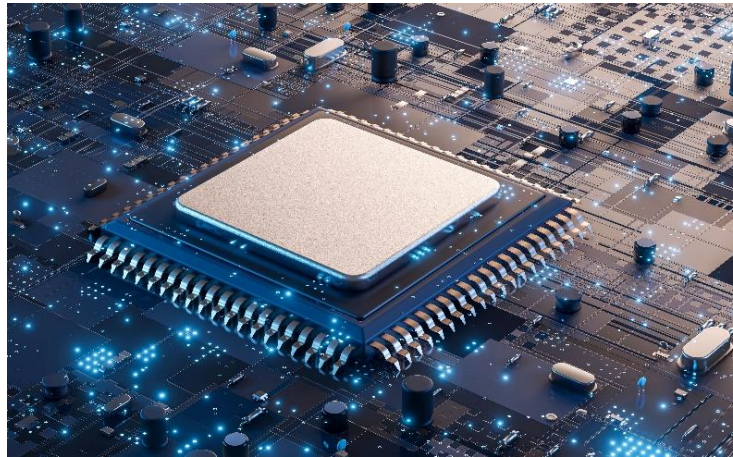

Modularity

Efficient valve combinations

Optimized envelope size and flow

High customization

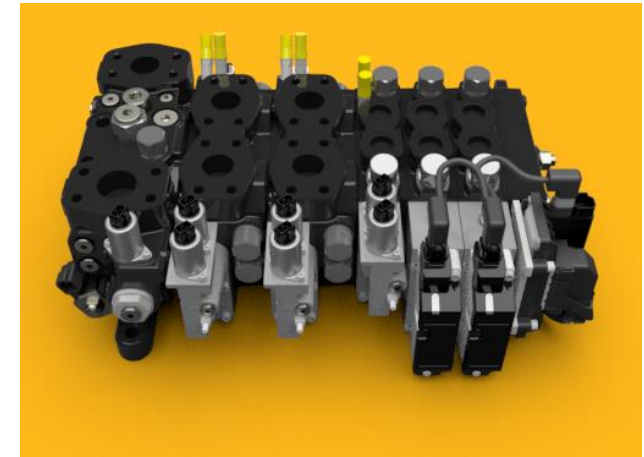

VA Series

Customer Values

Increased Flow Range

New markets

New applications

Machine efficiency



Compact Design and Serviceability

Reduced space claim

Common layout between valve sizes

Simplified installation and service

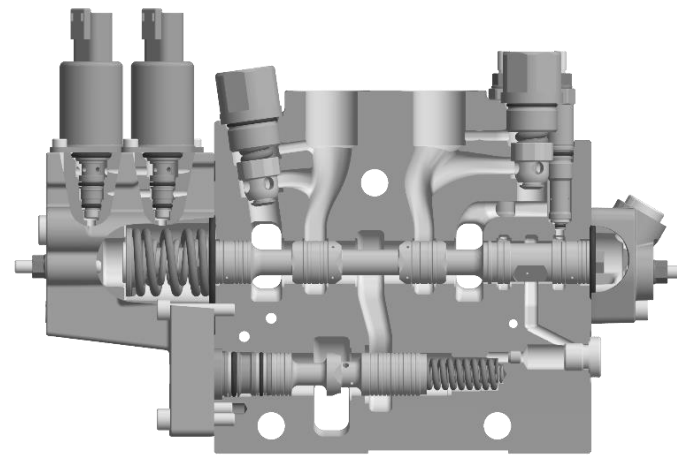

Sustainability

ISO 14001 certified facility

Reduction in size

Reduced environmental footprint



VA Series

Why VA Series?

Modern platform

- Neat packaging of new functions
- Flexible & Efficient combination possibilities
- On board electronics VC1
- Future development focus

Reduced space claim

- Compact solution
- Main spool, spring pack, compensator & pilot valves accessible from same side
- Section component layout consistent for all VA Series valves
- No mounting brackets

Future efficient combinations

- Combine with future VA Series valves without complex combination inlets
- Same tie rod interface throughout valve stack

Increased performance

- Increased flow range
- Increased pressure rating

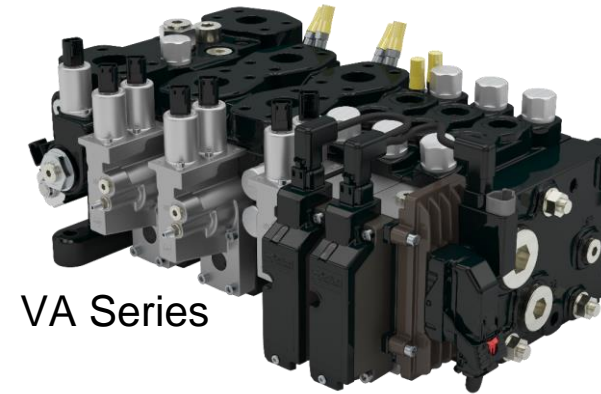

VA Series



VA450



VA300



Key Attributes

VA450

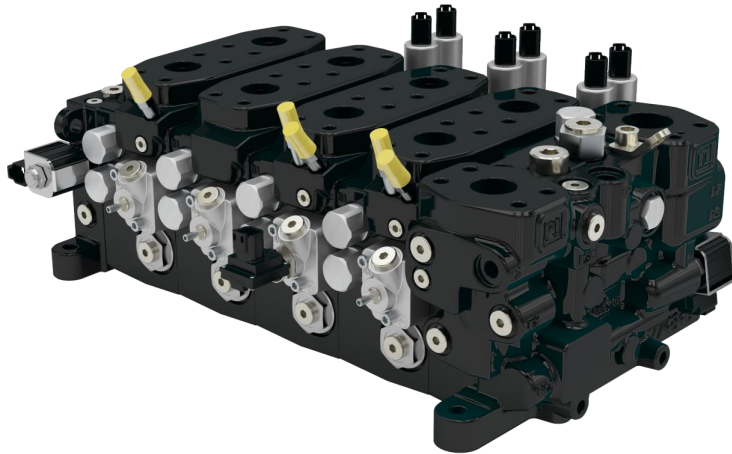

- Maximum operating pressure 380 bar
- Flow rate from workport 450 l/min at ΔP (P-LS) 20 bar
- Proportional spool actuators electric and hydraulic
- Function adapted spools
- Pre-compensated valve with possibility of flow sharing function
- Spool position and workport pressure sensors used for diagnostics
- Oil circulation circuit
- Float function in end section
- Individual workport pressure LS limiters
- Electric proportional workport pressure LS limiter
- Port relief valves with good precision
- Low internal leakage from pump to tank
- Designed for high duty applications, long fatigue life
- Service and installation friendly
- Function-adapted manifolds to meet specific requirements