



**Parker Hannifin Corporation
Cylinder Division**
500 South Wolf Road
Des Plaines, IL 60016
(847) 298-2400

**Parker Hannifin Corporation
Motion and Control Division**
160 Chisholm Drive
Milton, Ontario
Canada L9T 3G9
(905) 693-3000

Service Bulletin 1110-M3

**Series 2H, 2HD, 7" & 8" Bore
3H & 3HD, VH, HD, 3L & 2A
Hydraulic/Pneumatic Cylinders**

Issued: September, 2021
Supersedes: November, 2009

Series 2H, 2HD, 7" & 8" Bore 3H & 3HD, VH, HD, 3L & 2A Hydraulic and Pneumatic Cylinders

Parts Identification, Maintenance Instructions & Seal Kits

Service Assemblies and Seal Kits

Service Assemblies and Seal Kits for Parker hydraulic and pneumatic cylinders simplify the ordering and maintenance processes. They contain sub-assemblies which are ready for installation, and are supplied with full instructions. When ordering Service Assemblies and Seal Kits, please refer to the identification plate on the cylinder body, and supply the following information:

Serial Number - Bore - Stroke - Model Number - Fluid Type

Key to Part Numbers

- 1 Head
- 7 Cap
- 14 Gland
- 15 Cylinder body
- 17 Piston
- 18 Cushion sleeve
- 19 Tie rod
- 23 Tie rod nut
- 26 Back-up washer
(7" & 8" 3H, VH & HD Series)
- 27 Retainer
- 34 Piston rod
- 40 Wiperseal – for 14

- 71 Ball – cushion check valve
- 72 Cushion check valve screw
- 73 Floating cushion bushing
- 74 Retaining ring for cushion bushing
- 115 Back-up washer, gland to head o-ring
- 119³ Hi-Load Piston seal
- 120³ Energizing ring for Hi-Load seal
- 121 Wear ring for Hi-Load piston and 8" & larger 2A Series cylinders
- 122 Retainer Bolt

¹ 3L uses 2 or 3 rings; all other series use 4 rings.

² In some cases, the adjusting screw is installed in a cartridge.

³ 7" & 8" Bore HD, 3H & 3HD cylinders have only one Hi-Load piston seal and energizing ring.

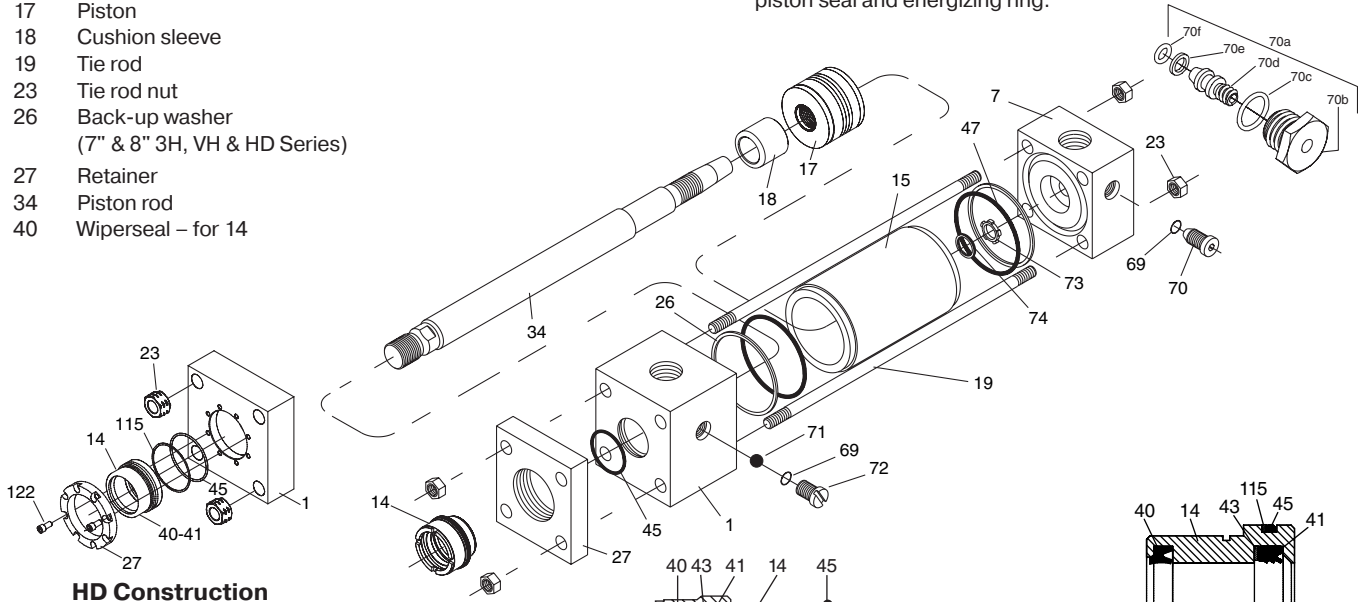

HD Construction

**2H, 3H, VH, 3L & 2A
Gland Assembly**

HD Gland Assembly

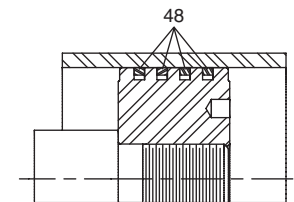

**Ring Type Piston
(All Series except 2A)**

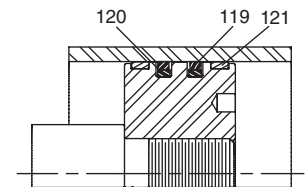

**Hi-Load Piston
(All Series except 2A & 3L)**

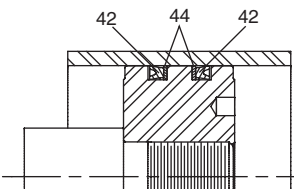

Lipseal Piston (All Series)

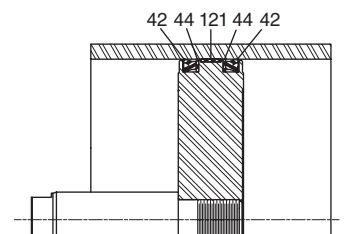

**Lipseal Piston with Wear Ring
2A Series Bores 8, 10, 12 & 14**

- 41 Lipseal – for 14
- 42 Lipseal, Piston
- 43 Back-up washer, gland lipseal 41
(not hydraulic Class 1 seals)
- 44 Back-up washer, Lipseal
- 45 O-ring – gland/head
- 47 O-ring – cylinder body
- 48¹ Cast iron rings
- 69 O-ring – needle valve and check valve screws
- 70² Needle valve, cushion adjustment
- 70a² Needle valve, cushion adjustment – cartridge type
- 70b Cartridge screw
- 70c O-ring – cartridge screw
- 70d Needle screw
- 70e Back-up washer – needle screw
- 70f O-ring – needle screw

(See Bulletin 1110-M4 for 2HD and 3HD Gland Assembly Instructions)

Operating Fluids and Temperature Ranges

The table shows the main types of fluid used with hydraulic cylinders. If the operating conditions of the particular application cannot be met

by the seal classes described, please consult the factory and supply complete application details.

| Class No | Typical Fluids | Temperature Range |
|--|--|---|
| 1 Nitrile & Polyurethane | Air, Nitrogen, Hydraulic Oil, Mil-H-5606 Oil | -10°F (-23°C) to +165°F (+74°C) |
| 2 Nitrile, Nitroxile and Fluorocarbon | Water, Water Glycol, H.W.C.F. - See Class 6 below. Water-in-Oil Emulsion - Houghto-Safe 271, 620, 5040 Mobil Pyrogard D, Shell IruS 905 Ucon Hydrolube J-4 | -10°F (-23°C) to +165°F (+74°C) |
| 5 Fluorocarbon | High Temperature Houghto-Safe 1010, 10551 1120 Fyrquel 150, 220, 300, 550 Mobil Pyrogard 42, 43, 53, 55 Note: Fluorocarbon seals are not suitable for use with Skydrol fluid, but can be used with hydraulic oil if desired. | -10°F (-23°C) to +250°F (+121°C) (Class 5 seals may be operated up to +400°F [+204°C] with reduced service life) |
| 6 Nitroxile, Fluorocarbon, and Nitrile | H.W.C.F. - Houghton Hydrolubric 120B Sonsol Lubrizol, for other H.W.C.F. consult factory | +40°F (+4°C) to +120°F (+49°C) |

Service Kit Numbers

Gland Cartridge Kits and Rod Seal Kits

Series 2H, 7" & 8" Bore 3H, VH & 3L**

| Rod. Dia. | Seal Type | | | |
|-----------|--|----------------|----------------------------|----------------|
| | Class 1 Service (Polyurethane & Nitrile) | | Class 2 Service* (Nitrile) | |
| | Gland Cartridge Kits† | Rod Seal Kits† | Gland Cartridge Kits† | Rod Seal Kits† |
| 1/2 | RG2HLTS051 | RK2HLTS051 | RG2AHL0051 | RK2AHL0051 |
| 5/8 | RG2HLTS061 | RK2HLTS061 | RG2AHL0061 | RK2AHL0061 |
| 1 | RG2HLTS101 | RK2HLTS101 | RG2AHL0101 | RK2AHL0101 |
| 1 3/8 | RG2HLTS131 | RK2HLTS131 | RG2AHL0131 | RK2AHL0131 |
| 1 3/4 | RG2HLTS171 | RK2HLTS171 | RG2AHL0171 | RK2AHL0171 |
| 2 | RG2HLTS201 | RK2HLTS201 | RG2AHL0201 | RK2AHL0201 |
| 2 1/2 | RG2HLTS251 | RK2HLTS251 | RG2AHL0251 | RK2AHL0251 |
| 3 | RG2HLTS301 | RK2HLTS301 | RG2AHL0301 | RK2AHL0301 |
| 3 1/2 | RG2HLTS351 | RK2HLTS351 | RG2AHL0351 | RK2AHL0351 |
| 4 | RG2HLTS401 | RK2HLTS401 | RG2AHL0401 | RK2AHL0401 |
| 4 1/2 | RG2HLTS451 | RK2HLTS451 | RG2AHL0451 | RK2AHL0451 |
| 5 | RG2HLTS501 | RK2HLTS501 | RG2AHL0501 | RK2AHL0501 |
| 5 1/2 | RG2HLTS551 | RK2HLTS551 | RG2AHL0551 | RK2AHL0551 |

Series HD

| Rod. Dia. | Seal Type | |
|-----------|---|----------------|
| | Class 1 Service*** (Polyurethane & Nitrile) | |
| | Gland Cartridge Kits† | Rod Seal Kits† |
| 5/8 | RG1HDL0061 | RK1HDL0061 |
| 1 | RG1HDL0101 | RK1HDL0101 |
| 1 3/8 | RG1HDL0131 | RK1HDL0131 |
| 1 3/4 | RG1HDL0171 | RK1HDL0171 |
| 2 | RG1HDL0201 | RK1HDL0201 |
| 2 1/2 | RG1HDL0251 | RK1HDL0251 |
| 3 | RG1HDL0301 | RK1HDL0301 |
| 3 1/2 | RG1HDL0351 | RK1HDL0351 |
| 4 | RG1HDL0401 | RK1HDL0401 |
| 4 1/2 | RG1HDL0451 | RK1HDL0451 |
| 5 | RG1HDL0501 | RK1HDL0501 |
| 5 1/2 | RG1HDL0551 | RK1HDL0551 |

* **Series 2H, 7 & 8" Bore 3H, VH, & 3L** rod gland cartridge kit & rod seal kit part numbers shown identify class 2 seals. To order class 5 or 6 seals substitute 5 or 6 as required for the last digit of the kit number.

** See Bulletin 1110-M4 for gland cartridge kits and rod seal kits to service Series 2HD and 7" & 8" bore 3HD cylinders.

*** **Series HD** rod gland cartridge kit & rod seal kit part numbers shown identify class 1 seals. To order class 1, 2, 5 or 6 seals substitute 1, 2, 5, or 6 as required for the last digit of the kit number.

Series 2A

| Rod. Dia. | Seal Type | | | |
|-----------|---------------------------|----------------|---------------------------------|----------------|
| | Class 1 Service (Nitrile) | | Class 5 Service* (Fluorocarbon) | |
| | Gland Cartridge Kits† | Rod Seal Kits† | Gland Cartridge Kits† | Rod Seal Kits† |
| 1/2 | RG2AHL0051 | RK2AHL0051 | RG2AHL0055 | RK2AHL0055 |
| 5/8 | RG2AHL0061 | RK2AHL0061 | RG2AHL0065 | RK2AHL0065 |
| 1 | RG2AHL0101 | RK2AHL0101 | RG2AHL0105 | RK2AHL0105 |
| 1 3/8 | RG2AHL0131 | RK2AHL0131 | RG2AHL0135 | RK2AHL0135 |
| 1 3/4 | RG2AHL0171 | RK2AHL0171 | RG2AHL0175 | RK2AHL0175 |
| 2 | RG2AHL0201 | RK2AHL0201 | RG2AHL0205 | RK2AHL0205 |
| 2 1/2 | RG2AHL0251 | RK2AHL0251 | RG2AHL0255 | RK2AHL0255 |
| 3 | RG2AHL0301 | RK2AHL0301 | RG2AHL0305 | RK2AHL0305 |
| 3 1/2 | RG2AHL0351 | RK2AHL0351 | RG2AHL0355 | RK2AHL0355 |
| 4 | RG2AHL0401 | RK2AHL0401 | RG2AHL0405 | RK2AHL0405 |
| 4 1/2 | RG2AHL0451 | RK2AHL0451 | RG2AHL0455 | RK2AHL0455 |
| 5 | RG2AHL0501 | RK2AHL0501 | RG2AHL0505 | RK2AHL0505 |
| 5 1/2 | RG2AHL0551 | RK2AHL0551 | RG2AHL0555 | RK2AHL0555 |

† **Contents and Part Numbers of Seal Kits For Glands** (See key to part numbers on page 1)

Gland Cartridge Kits – Contain items 14, 40, 41, 45, 115 (HD only), (43 class 2, 5, & 6 only)

Rod Seal Kits – Contain items 40, 41, 45, 115 (HD only), (43 class 2, 5, & 6 only)

Cushion Screw Assembly – Screw type: 69, 70. Cartridge type: 70, b, 70c, 70d, 70e, 70f

Cushion Assembly – Screw type: 69, 71, 72



**Piston Seal Kits and Body Seal Kits
Series 2H, 7 & 8" Bore 3H, VH, HD & 3L**

| Bore Size | Class 1 & 2 Service* | | | | |
|-----------|--------------------------------------|--------------------------------------|----------------------------------|-----------------|-------------|
| | Piston Seal Type | | | Body Seal Kits† | |
| | Piston Lipseal Kits† | Piston Ring Kits† | Hi-Load Piston Seal Kits† | | |
| | Series 2H, 2HD, 3H, 3HD, VH, HD & 3L | Series 2H, 2HD, 3H, 3HD, VH, HD & 3L | Series 2H, 2HD, 3H, 3HD, VH & HD | | |
| 1 | PK102HLL01 | PR102H0001 | - | CB102HL0001 | |
| 1 1/2 | PK152HLL01 | PR152H0001 | PK152HK001 | CB152HL0001 | |
| 2 | PK202HLL01 | PR202H0001 | PK202HK001 | CB202HL0001 | |
| 2 1/2 | PK252HLL01 | PR252H0001 | PK252HK001 | CB252HL0001 | |
| 3 1/4 | PK322HLL01 | PR322H0001 | PK322HK001 | CB322HL0001 | |
| 4 | PK402HLL01 | PR402H0001 | PK402HK001 | CB402HL0001 | |
| 5 | PK502HLL01 | PR502H0001 | PK502HK001 | CB1502HL0001 | |
| 6 | PK602HLL01 | PR602H0001 | PK602HK001 | CB602HL0001 | |
| 7 | Excp 3H & 3HD | PK702HLL01 | PR702H0001 | PK702HK001 | CB702HL0001 |
| | 3H & 3HD | N/A | PR703H0001 | PK703HK001 | CB703HL0001 |
| 8 | Excp 3H & 3HD | PK802HLL01 | PR802K0001 | PK802HK001 | CB802HL0001 |
| | 3H & 3HD | N/A | PR803H0001 | PK803HK001 | CB803HL0001 |

* Series 2H, 2HD, 7 & 8" Bore 3H & 3HD, VH, HD & 3L piston seal kit & body seal kit part numbers shown identify class 1 & 2 seals. To order class 5 or 6 seals substitute 5 or 6 as required for the last digit of the kit number.

† **Contents and Part Numbers of Seal Kits For Pistons & Bodies**
(See key to part numbers on page 1)

Piston Lipseal Kits – (Includes Cylinder Body End Seals) Contain two each of items 47, 42, & 44 (26 3H, 3HD, & 7" - 8" HD only).

Piston Ring Kits – (Includes Cylinder Body End Seals) Contain two each of item 47, (26 3H, 3HD, & 7" - 8" HD only) & four each of item 48.

Hi-Load Piston Seal Kits – (Includes Cylinder Body End Seals): Contains two each of items 47, 119, 120 & 121 (26 3H, 3HD, & 7" - 8" HD only).

Cylinder Body End Seal Kits – Contains two each of item 47 (26 3H, 3HD, & 7" - 8" HD only).

Series 2A

| Bore Size | Piston Seal Kits | | Body Seal Kits | |
|-----------|-------------------------------|--------------------------------|-------------------------------|--|
| | Class 1 & 2 Service (Nitrile) | Class 5 Service (Fluorocarbon) | Class 1 & 2 Service (Nitrile) | Class 5 Service (Fluorocarbon) |
| 1 | PK1002A001 | PK1002A005 | CB102HL001 | CB102HL005 |
| 1 1/2 | PK1502A001 | PK1502A005 | CB152HL001 | CB152HL005 |
| 2 | PK2002A001 | PK2002A005 | CB202HL001 | CB202HL005 |
| 2 1/2 | PK2502A001 | PK2502A005 | CB252HL001 | CB252HL005 |
| 3 1/4 | PK3202A001 | PK3202A005 | CB322A0001 | USE (PK) PISTON SEAL KITS FOR THESE SIZES |
| 4 | PK4002A001 | PK4002A005 | CB402A0001 | |
| 5 | PK5002A001 | PK5002A005 | CB502A0001 | |
| 6 | PK6002A001 | PK6002A005 | CB602A0001 | |
| 7 | PK7002A001 | PK7002A005 | CB702A0001 | |
| 8 | PK8002A001 | PK8002A005 | CB802A0001 | |
| 10 | PK9002A001 | PK9002A005 | CB902A0001 | |
| 12 | PK9202A001 | PK9202A005 | CB922A0001 | |
| 14 | PK9402A001 | PK9402A005 | CB942A0001 | |

Cylinder Modifications or Repairs

Cylinders as shipped from the factory are not to be disassembled and or modified. If cylinders require modifications, these modifications must be done at company locations or by The Company's certified facilities. The Cylinder Division Engineering Department must be notified in the event of a mechanical fracture or permanent deformation of any cylinder component (excluding seals). This includes a broken piston rod, tie rod, mounting accessory or any other cylinder component. The notification should include all operation and application details. This information will be used to provide an engineered repair that will prevent recurrence of the failure.

It is allowed to disassemble cylinders for the purpose of replacing seals or seal assemblies. However, this work must be done by strictly following all the instructions provided in this bulletin.

Although Parker Hydraulic Cylinders are designed to make on-site maintenance or repairs as easy as possible, some operations can only be carried out in our factory. It is standard policy to fit a cylinder returned to the factory for repair with those replacement parts which are necessary to return it to 'as good as new' condition. Should the condition of the returned cylinder be such that repair would be uneconomical, you will be notified.

The piston is sealed and securely locked to the piston rod with an-aerobic adhesive. This threaded connection is ONLY to be disassembled or reassembled by factory trained personnel.

⚠ WARNING: Some cylinders contain heavily loaded springs. Improper disassembly of these cylinders can cause severe bodily injury or death. Always disassemble a cylinder containing a spring by following the instructions in Bulletin 0805-G-TSD-1.

After the cylinder has been disassembled, carefully remove the seals that will be replaced to avoid damaging groove surfaces. Carefully clean all parts.

Seals will be easier to install if they are lubricated. Always lubricate seals and other components of a hydraulic cylinder with the operating fluid. Pneumatically operated cylinders should be lubricated with Lub-A-Cyl. Neither hydraulic nor pneumatic cylinders fitted with Class 3 seals (EPR) can be lubricated or operated with petroleum based products.

Servicing Piston Seals

The cylinder bore and piston must be closely examined for signs of scoring. If either the cylinder body or piston is damaged they must be replaced.

When a cylinder is overhauled, a new set of piston seals is required. It is also recommended that the cylinder be reassembled with new cylinder body O-rings. All piston seal kits contain piston seals as well as two cylinder body O-rings (47) and for 7 and 8 inch bore hydraulic cylinders, their mating back-up washers (26).

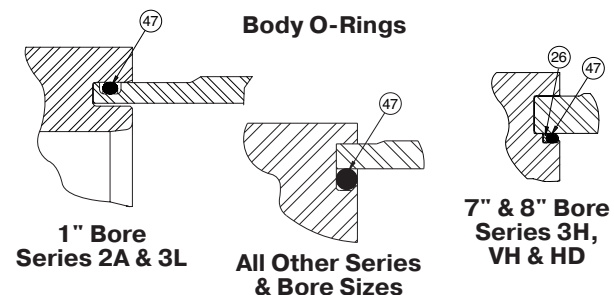

Lipseal Piston

PK kits for Lipseal pistons contain two lipseals (42) and two back-up washers (44). Additionally, kits for 8 inch bore and larger 2A Series cylinders contain one wear ring (121).

Apply lubricant to the piston OD and all grooves. Install one piston seal in the groove nearest the rod. The two 'lips' of this Lipseal should face toward the rod end of the piston. Install the back-up washer in the same groove opposite the 'lips' of the seal. Lubricate the cylinder body ID and insert the piston – cap end first – into the cylinder body as shown.

Next, turn the cylinder body on its side and push the piston through the tube just far enough to expose the groove for the second seal. Now, install the second Lipseal and back-up washer in the exposed groove with the two 'lips' facing away from the rod. If the piston has a groove for a wear ring, install the wear ring in the groove and lubricate the wear ring OD. Then pull the piston into the cylinder body.

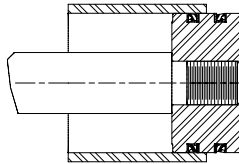

Hi-Load Piston

Kits for Hi-Load pistons contain two sets of seals for Series 2H and 2HD cylinders, and for 1½" - 6" bore Series HD cylinders. They contain one set of seals for Series 3H and 3HD cylinders, and for 7" - 8" bore Series HD and VH cylinders. Each seal set includes one filled PTFE sealing ring (119) and an elastomeric energizing ring (120). The kit also contains two wear rings. (121). Install the inner energizing ring(s) in the seal groove(s).

Install the wear rings in the two grooves on each end of the piston. Stretch the PTFE seal ring(s) by hand until it fits over the wear ring. Push the outer ring(s) over the wear ring and into the seal groove(s). With the outer ring(s) in the groove(s), compress them with a ring compressor. Alternatively, the PTFE rings can be compressed using a large hose clamp over thin shim stock. In all cases, take care not to damage the sealing ring(s). Keep the sealing ring(s) compressed for some time before inserting the piston into the body. A starting sleeve having an ID the same size as the cylinder bore, and tapered at one end, will aid the installation process.

Cast Iron Piston Rings

Kits for cast iron piston rings contain four rings (48). Most 3L Series cylinders use only three rings and in some larger sizes, only two. All other series cylinders use four rings.

Iron piston rings seldom need replacement. If the rings show no signs of damage or abnormal wear, they may be reused. To install piston rings, collapse the rings one at a time while inserting the piston into the cylinder body, using a light oil to aid this process.

Cylinder Assembly

The cylinder should be re-assembled as follows:

- 1) The back-up washers, where fitted, and then the body O-rings should be lightly lubricated and pressed into the grooves in the head and cap, without twisting. The cylinder body, with the piston and rod already fitted, can then be assembled to the cap by 'rocking' it down over the O-ring until the cylinder body is in contact with the cap. The head is then fitted over the piston rod and assembled to the cylinder body. Rock gently until the body and head are in metal-to-metal contact.
- 2) Lightly lubricate the gland seals.
- 3a) Cylinders having a threaded gland (All cylinders except HD Series)

Screw the gland into the retainer about one thread short of the retainer face that contacts the cylinder head. Slide the gland/retainer assembly over the piston rod end, taking care not to damage the seal lips. Orient holes in full square retainers over the tie rod holes in the head or line up holes in smaller retainers with threaded mounting holes. Assemble bolts that secure bolt-on retainers finger tight.

3b) HD Series Cylinders

Slide the gland/retainer/head assembly over the piston rod end, taking care not to damage the seal lips.

- 4) Ensuring that the head and cap are kept in alignment, refit the cylinder tie rods.

Note: Some cylinder configurations have tie rods threaded into a component other than tie rod nuts (e.g. head, cap, flange plate, etc). Before torquing the tie rods, use paint on the tie rods as an indicator that adequate thread engagement is achieved. Ensure that no unpainted thread is exposed at the connection to the mating component.

For both style retainers, torque tie rod nuts to values listed on page 6. **Torque tie rods gradually starting at one corner and work in a diagonal pattern to ensure evenness of tightening. DO NOT TORQUE ONE TIE ROD COMPLETELY AND THEN THE OTHERS.** Then, on cylinders with bolt-on retainers, torque bolts to the values listed on page 6.

Trunnion Mounts

Trunnion mount with trunnion in groove on cylinder body – Torque cap end tie rods to value listed in table, then torque head tie rods to the same value.

Trunnion mounts with trunnion located against a single shoulder on the cylinder body – Torque tie rods on the larger diameter side of the shoulder to approx. 10% of torque table value. Then torque the tie rods on the opposite end to the full table value.

Trunnion mounts located on a cylinder body without a shoulder – Assemble short set of tie rods first, using paint marks on the cylinder body as a location guide. Ensure the trunnion pins are square to the body. Install the longer tie rods and torque to values in the table.

- 5) To complete the assembly of cylinders with a threaded gland, tighten the gland firmly against the cylinder head. To aid this process, a Gland Wrench Set should be used. A specially designed face-type gland wrench with flared lugs slips into an exact, sure fit on the gland, while a self-locking spanner wrench grips the gland wrench securely. You can order the Cartridge Wrench or Spanner Wrench to fit the piston rod size used in your Parker Hannifin Cylinder. See table on page 5.

Servicing Cushion Needle and Check Valves

Leakage from cushion adjusters or check valve screws indicates that the screw or cartridge-type assembly must be replaced. The replacement assembly includes a new O-ring.

Removal

The screw/cartridge assembly should be unscrewed and its mounting hole cleaned, paying close attention to the surface on which the O-ring sits.

Installation – Cushion Needle Valves

Where a cartridge-type adjuster is fitted, lightly lubricate the screw threads and torque to the figures shown in the table on page 6. With both types, the hex-headed screw may be adjusted to provide the required cushioning performance.

Installation – Check Valve

Ensure that the ball is correctly positioned. Screw-type adjusters should be screwed fully home, and then backed off by a full turn.

Servicing Cylinder Gland Seals

Fluid leakage from the piston rod at the gland normally indicates worn gland seals. The cylinder should, if possible, be removed for overhaul, or the piston rod disconnected.

Removal

- 1) Inspect the piston rod to make sure it is free from burrs or damage which would prevent the gland sliding off the rod.

The Parker gland is a cartridge design consisting of a bronze gland (14), primary rod seal (41), back-up washer (43) for all hydraulic cylinder seal classes, and a double lip wiperseal (40). For HD Series cylinders the gland kit also contains an O-ring (45) and back-up washer (115) that seals the gland to the

cylinder head. The HD gland is usually held in place with a bolt-on retainer. However, some HD Series mounting styles in bores 1½"-4" with code 2 piston rod diameters will utilize a retainer plate held in place by tie rods. For all other series of cylinders, the gland is threaded into a gland retainer plate. These glands are usually removable without disturbing the tie rod torque. In some cases, where a large diameter rod gland is threaded into a large square retainer, it may be necessary to loosen the tie rods to remove the gland.

- 2) Where the gland is screwed into a square retainer, unscrew the gland using a Gland Wrench and Spanner described on the previous page, and slide the gland off the piston rod.

Where the gland is screwed into a circular retainer, undo the socket head cap screws and slide the gland/retainer assembly off the piston rod. Unscrew and withdraw the gland from the inner face of the retainer.

- 3) Remove the seals using a sharp pointed instrument, taking care not to damage the gland. Clean and inspect the gland bore and seal grooves. If any wear is present replace with a Gland Cartridge Kit containing seals of the correct type for the conditions.

Installation

Inspect the surface of the piston rod for damage which could cause early seal failure. When fitting the gland over the rod thread, a slight rotary motion will help prevent damage to the seals. In addition, shim stock or other thin, tough material can be wrapped around the threads to protect the seal lips.

- 1) Ensure that the kit contains seals of the correct type. Lubricate the gland and seals, and fit the wiper (40) into the groove closest to the outside face of the gland.

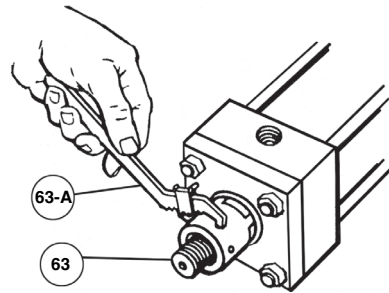
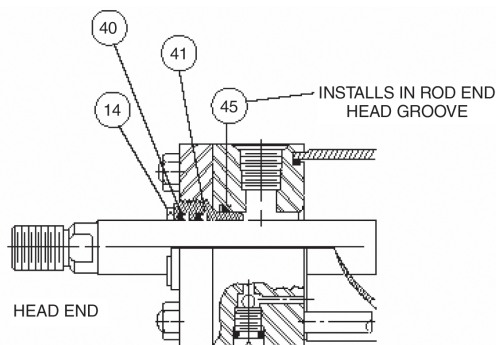

- 2) If a Class 1 material rod seal, for a hydraulic cylinder, is being fitted to a standard gland, no back-up washer is necessary. A back-up washer (43) is included in seal kits for all other service classes. Install this in the rod seal groove, against the wall closest to the wiper. Install the lip-seal (41) in the groove, **with the lips facing the pressure (cylinder) side of the gland.**
- 3) Before installing HD Series cylinder glands, replace O-ring (45) and back-up washer (115). Lubricate these components and install them into the groove at the base of the gland on the OD. Orient the O-ring and back-up washer as shown in the drawing on page 1.

All gland seals for HD Series cylinders, including the OD O-ring, must be lubricated prior to assembly. Slide the gland cartridge over the piston rod end thread and into the cylinder head. Place the retainer plate over the gland, install the mounting bolts and torque to the values listed on page 6. Note that some mounting styles in bores 1½"-4" with code 2 piston rod diameters will utilize a retainer plate held in place by tie rods.

- 4) Each kit with a threaded type gland contains an O-ring (45) which seals the gland to the cylinder head. This O-ring is a static seal, and the original must be left in place unless it is faulty.

Note: Some seal kits contain more than one O-ring. In this case, fit the one which is identical in size and thickness to the existing O-ring. Any extra O-rings should be discarded.

Slide the gland cartridge over the piston rod and thread it into the retainer. Tighten the gland firmly against the cylinder head using a Gland Wrench and Spanner. In some cases (especially large piston rod diameters) it may be necessary to loosen the tie rod nuts or retainer bolts, and remove the retainer, in order to thread the gland back into place. In those cases, thread the gland into the retainer about one thread short of the retainer face that contacts the cylinder head. Slide the gland assembly over the piston rod and orient holes in large retainers with tie rod holes and holes in bolt-on retainers with threaded mounting holes. Seat the retainer against the cylinder head. Assemble bolts that secure bolt-on retainers finger tight. For both style retainers, torque tie rod nuts to values listed on page 6. **Torque ties rods gradually starting at one corner and work in a diagonal pattern to ensure evenness of tightening. DO NOT TORQUE ONE TIE ROD COMPLETELY AND THE OTHERS.** Then, on cylinders with bolt-on retainers, torque bolts to the values listed on page 6. To complete the assembly, in all cases, tighten the gland cartridge firmly against the cylinder head using a Gland Wrench and Spanner.

Gland seals are pressure activated and do not need adjustment.

See Bulletin 1110-M4 for instructions to service gland and seals in Series 2HD and 3HD cylinders.

Tie Rod Torque

An extreme pressure lubricant (such as molybdenum disulphide) should be used on tie rod threads and nut bearing surfaces to control friction and reduce tie rod twist.

| Bore Size | | Tie Rod Torque Series 2A, 3L | |
|-----------|----|------------------------------|---------------|
| 1 | 2A | 15 - 17 lb-in | 17 - 19 kg-cm |
| | 3L | 35 - 40 lb-in | 41 - 47 kg-cm |
| 1 1/2 | | 60 - 70 lb-in | 69 - 81 kg-cm |
| 2 | | 11 - 12 lb-ft | 15 - 16 N-m |
| 2 1/2 | | 11 - 12 lb-ft | 15 - 16 N-m |
| 3 1/4 | | 25 - 26 lb-ft | 34 - 35 N-m |
| 4 | | 25 - 26 lb-ft | 34 - 35 N-m |
| 5 | | 60 - 64 lb-ft | 81 - 87 N-m |
| 6 | | 60 - 64 lb-ft | 81 - 87 N-m |
| 7 | | 90 - 94 lb-ft | 81 - 87 N-m |
| 8 | | 110 - 114 lb-ft | 149 - 155 N-m |
| 10 | | 148 - 155 lb-ft | 201 - 211 N-m |
| 12 | | 172 - 181 lb-ft | 233 - 245 N-m |
| 14 | | 275 - 289 lb-ft | 373 - 392 N-m |

Cartridge Cushion Adjuster Torque

| Nominal Screw Size | Torque | |
|--------------------|---------------|-------------|
| M8 | 6 - 7 lb-ft | 9 - 10 N-m |
| M10 | 18 - 22 lb-ft | 25 - 30 N-m |
| M14 | 44 - 48 lb-ft | 60 - 65 N-m |

| Rod Diameter | Gland Wrench (Symbol 63) | Spanner Wrench (Symbol 63-A) |
|--------------|--------------------------|------------------------------|
| 5/8" | 0695900000 | 0116760000 |
| 1" | 0695910000 | |
| 1 3/8" | 0695920000 | 0117030000 |
| 1 3/4" | 0695930000 | 0116770000 |
| 2" | 0695940000 | |
| 2 1/2" | 0695950000 | 0116770000 |
| 3" | 0695960000 | |
| 3 1/2" | 0695970000 | 0116780000 |
| 4" | 0695980000 | |
| 4 1/2" | 0838770000 | |
| 5" | 0695990000 | |
| 5 1/2" | 0696000000 | |

| Bore Size | Tie Rod Torque* | |
|-----------|---------------------------------|-----------------|
| | Series 2H, 2HD, 3H, 3HD, VH, HD | |
| 1 1/2 | 18 - 19 lb-ft | 24 - 25 N-m |
| 2 | 45 - 49 lb-ft | 61 - 67 N-m |
| 2 1/2 | 45 - 49 lb-ft | 61 - 67 N-m |
| 3 1/4 | 120 - 124 lb-ft | 163 - 169 N-m |
| 4 | 131 - 135 lb-ft | 178 - 184 N-m |
| 5 | 312 - 316 lb-ft | 423 - 429 N-m |
| 6 | 528 - 544 lb-ft | 716 - 738 N-m |
| 7 | 800 - 816 lb-ft | 1085 - 1107 N-m |
| 8 | 1168 - 1184 lb-ft | 1584 - 1606 N-m |

* The tie rod torque values listed in this table are intended for 2H, 2HD, 3H, 3HD, HD and VH Series cylinders having a pressure envelope pressure rating of 3000 psi. Consult factory for tie rod torque of 2H, 2HD, 3H, 3HD, HD and VH Series cylinders having a higher pressure rating.

**Retainer Bolt Torque
For Cylinders with Round Gland Retainers**

| Screw Size | Torque | |
|------------|---------------|---------------|
| #10 | 56 - 58 lb-in | 6.3 - 6.6 N-m |
| 1/4 | 11 - 12 lb-ft | 15 - 16 N-m |
| 5/16 | 23 - 24 lb-ft | 31 - 32 N-m |
| 3/8 | 41 - 43 lb-ft | 54 - 56 N-m |
| 7/16 | 65 - 68 lb-ft | 88 - 92 N-m |

⚠ PROP 65 WARNING

Warning: This product can expose you to chemicals including: Carbon Black which is known to the State of California to cause cancer; Lead and Lead Compounds which are known to the State of California to cause cancer and birth defects or other reproductive harm. For more information go to www.P65Warnings.ca.gov

⚠ Warning

FAILURE OR IMPROPER SELECTION OR IMPROPER USE OF THE PRODUCTS AND/OR SYSTEMS DESCRIBED HEREIN OR RELATED ITEMS CAN CAUSE DEATH, PERSONAL INJURY AND PROPERTY DAMAGE.

This document and other information from Parker Hannifin Corporation, its subsidiaries and authorized distributors provide product and/or system options for further investigation by users having technical expertise. It is important that you analyze all aspects of your application, including consequences of any failure and review the information concerning the product or system in the current product catalog. Due to the variety of operating conditions and applications for these products or systems, the user, through its own analysis and testing, is solely responsible for making the final selection of the products and systems and assuring that all performance, safety and warning requirements of the application are met.

The product described herein, including without limitation, product features, specifications, designs, availability and pricing, are subject to change by Parker Hannifin Corporation and its subsidiaries at any time without notice.

Offer of Sale

The items described in this document are hereby offered for sale by Parker Hannifin Corporation, its subsidiaries or its authorized distributors. This offer and its acceptance are governed by provisions stated in the 'Offer of Sale'.

