

VA450 Training

Next generation Load Sensing valves

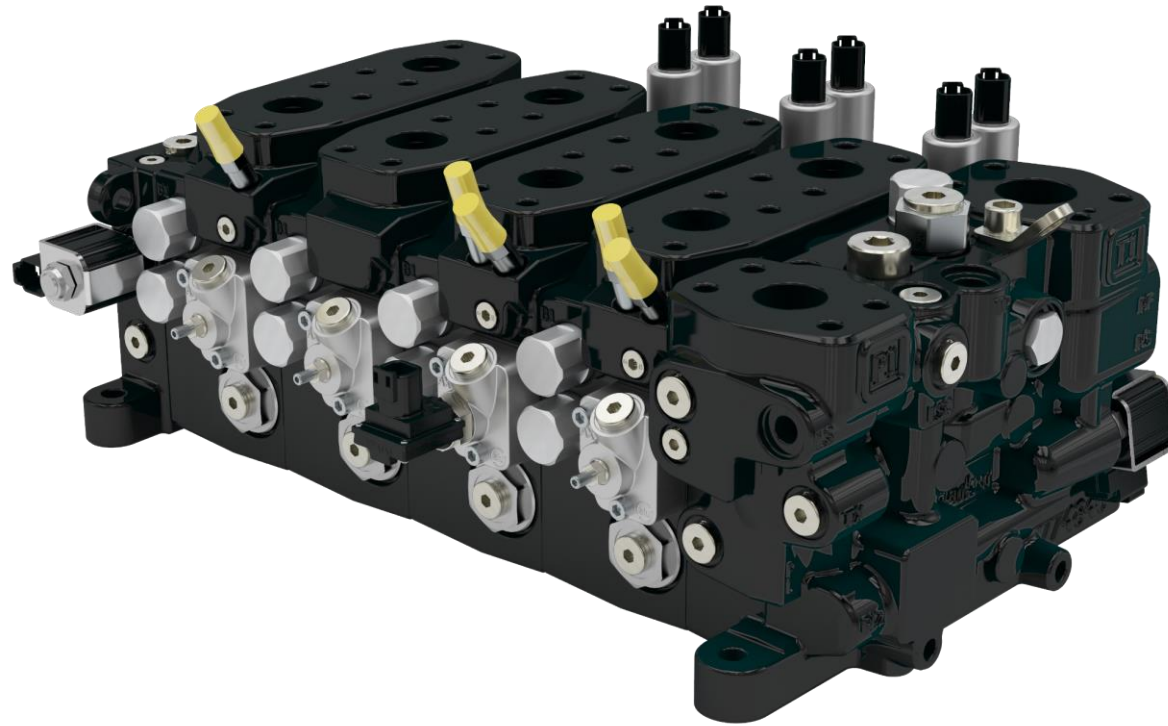

Leading with
Purpose

August 13, 2024

ENGINEERING YOUR SUCCESS.

VA450 Valve Layout

Proportional, Load sensing, Pre-compensated

- 1-8 work sections*
- Combinable with VA300 and future VA-valves in the same valve stack
- Each work section individually configurable
- Custom manifold integration possible
- Unique online configurator

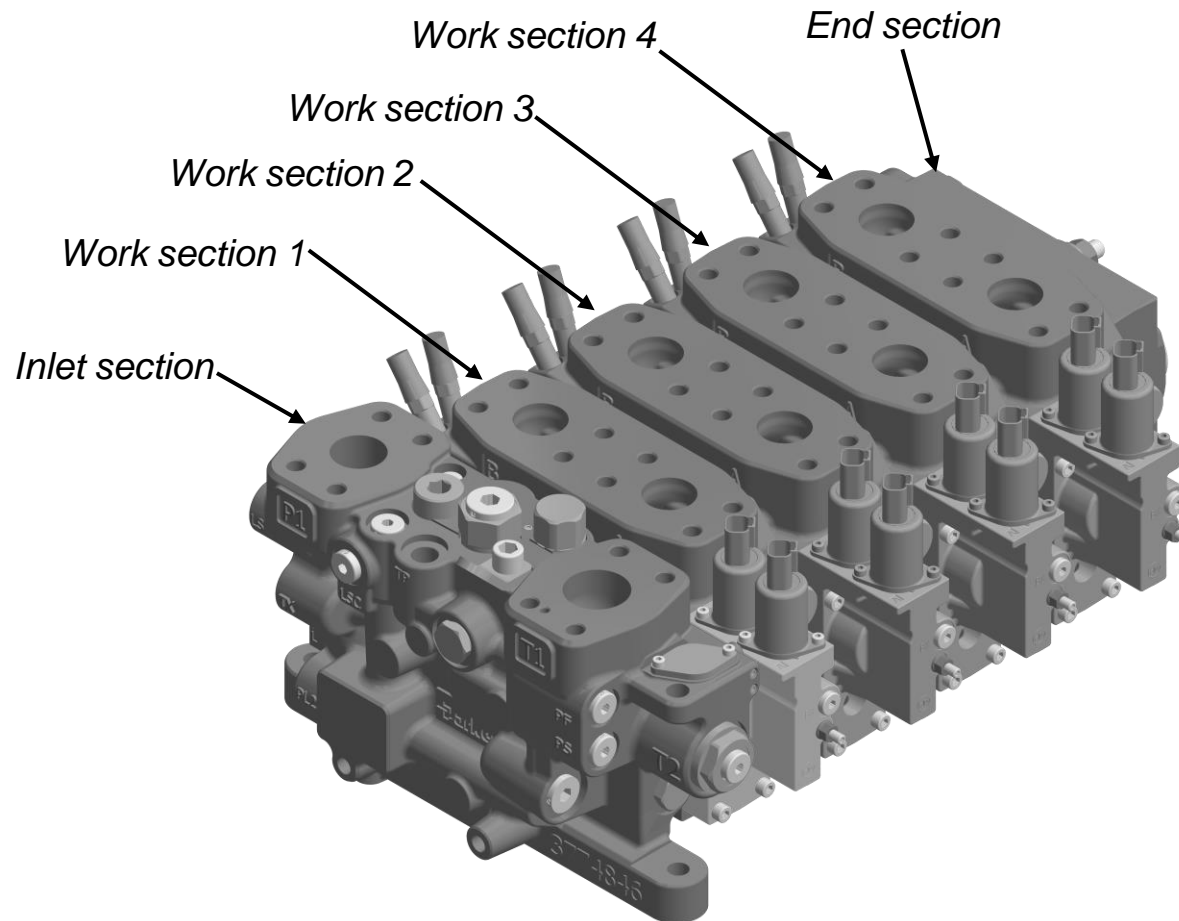

*See more information in the catalogue regarding combination-limits with VA300



VA450 Technical Data

Pressure, Flow and Dimensions

Max pressure, unlimited number of cycles:

- Pump: 380 bar
- Workport: 380 bar
- Tank: 20 bar

Flow capacity:

- Compensated flow to workport: 450 l/min

Dimensions

- Inlet section LS450
- End section US300:
- Work section WS450:

Section width

- 105 mm
- 47 mm
- 90 mm

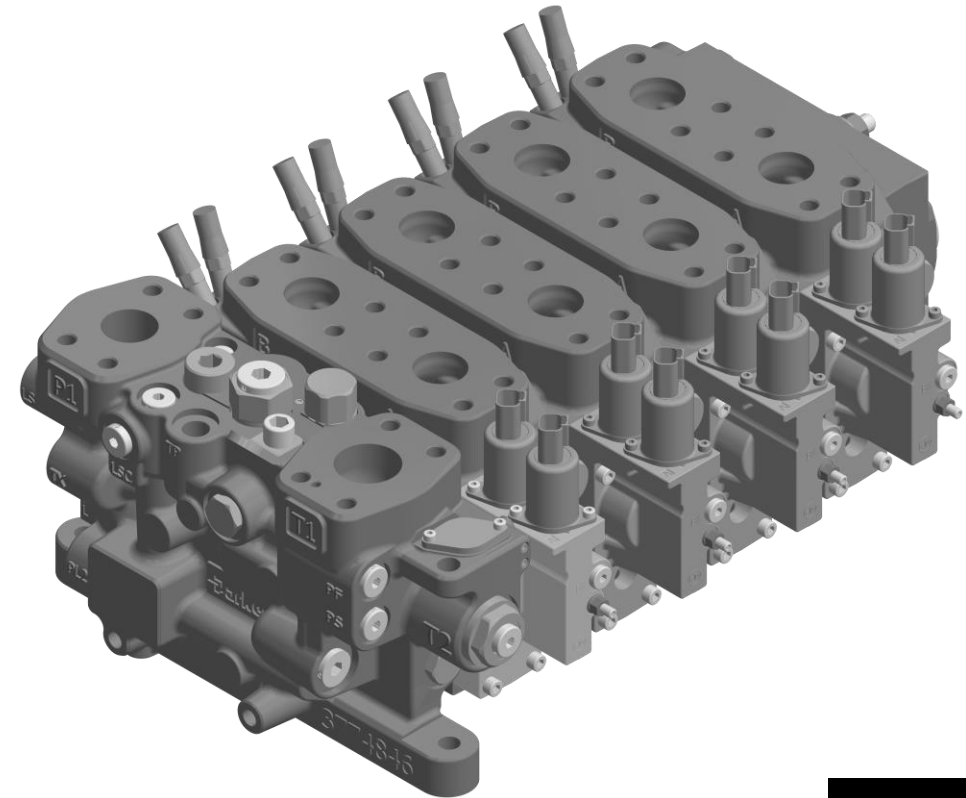

VA450 Inlet section

LS450

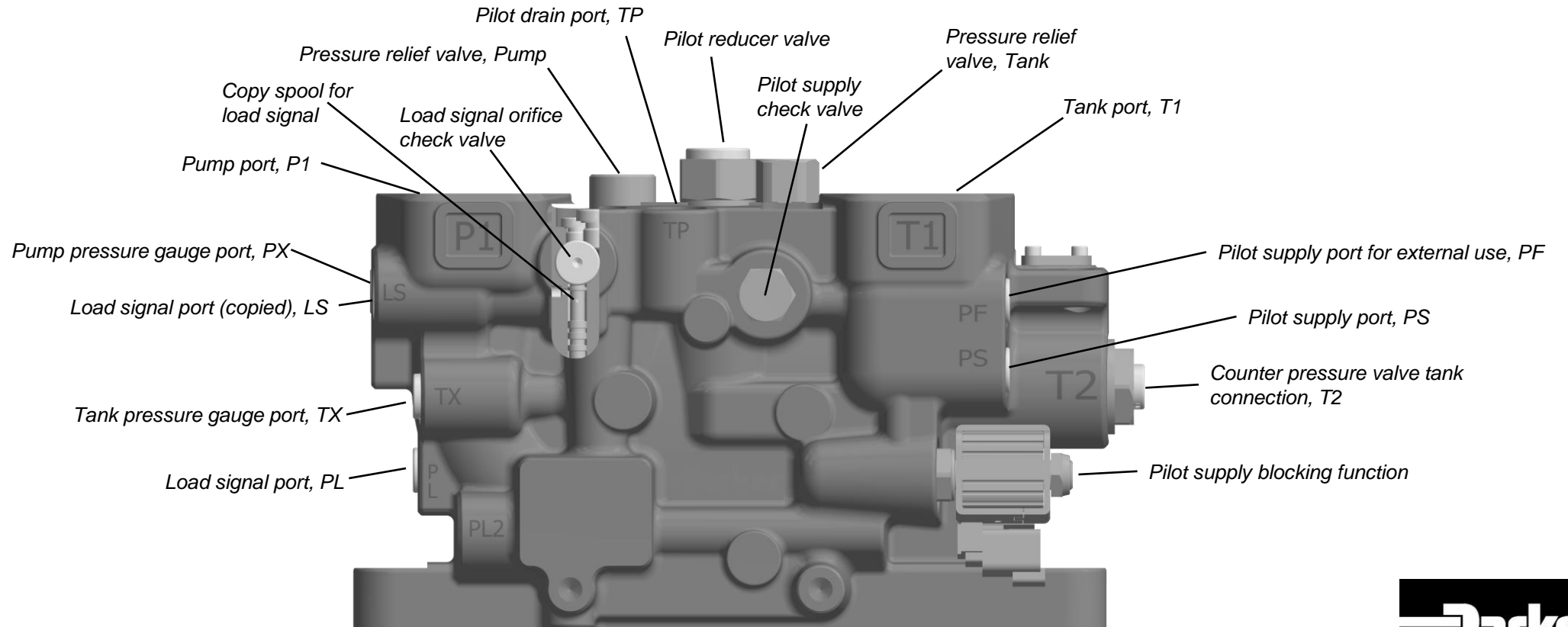

VA450 Inlet section

Functionality

- **Pump and tank ports**

- Connection ports:

- P1 – Pump port.
- PX – Pump pressure gauge port.
- T1 – Tank port.
- T2 – Tank port. Can be fitted with a counter pressure valve.
- TX – Tank pressure gauge port.

- Counter pressure valve - Increases the pressure in the valve's tank gallery to a fixed pressure level. By raising the counter pressure level, the anti-cavitation characteristics is improved. Available with active refill function allowing the tank gallery to be supplied with oil from the pump, further improving the anti-cavitation characteristics.

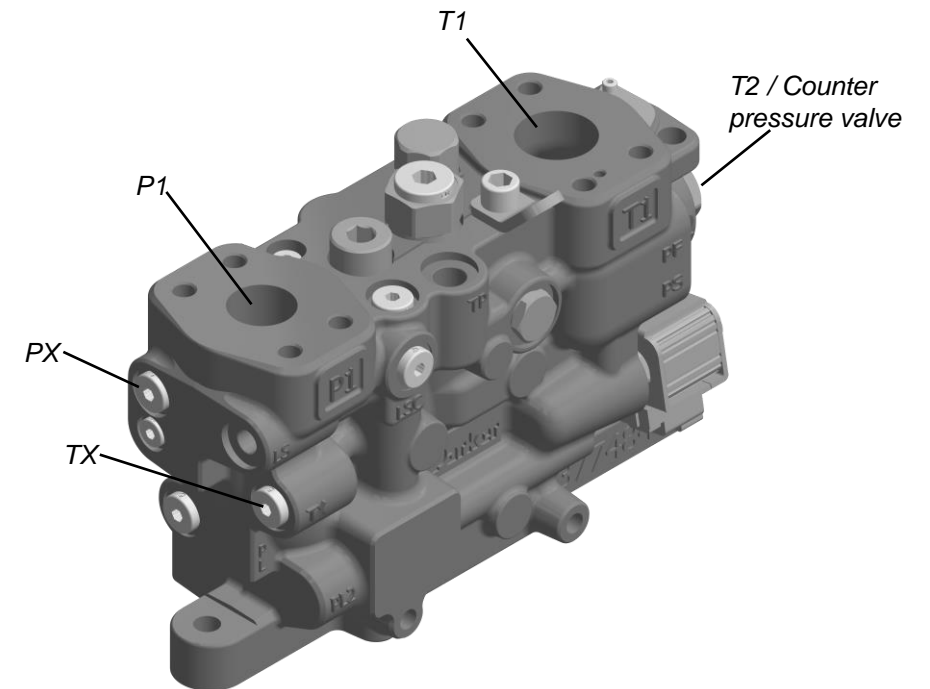

VA450 Inlet section

Functionality

- **Pressure limitation**
 - Main pressure relief valve in pump gallery – Protects pump and valve from pressure peaks in the system.
 - Pressure relief valve in tank gallery – Limits the pressure before the counter pressure valve in tank gallery to 50 bar.

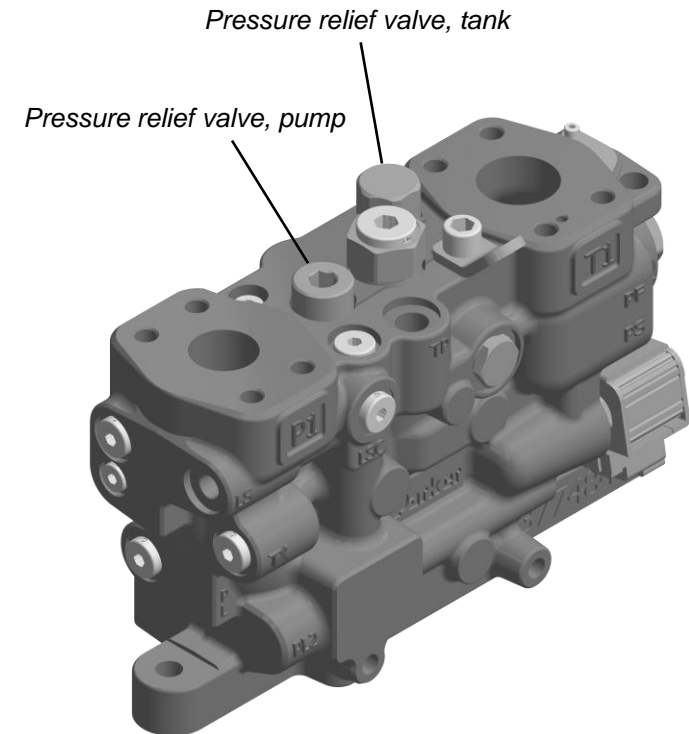

VA450 Inlet section

Functionality

- **Load signal system**

- Load signal copy function – Copies the highest load signal using pump oil and sends it to port LS. Avoids oil consumption from workport.
- Load signal orifice check valve – Restricts the flow towards the valve to allow for a smoother destroking of the pump in case of a sudden decrease in load pressure.
- Connection ports:
 - LS – Copied load signal. Primary port for connecting the load signal to the pump regulator. Oil supplied from pump.
 - PL – Uncopied load signal. Oil supplied from workport.

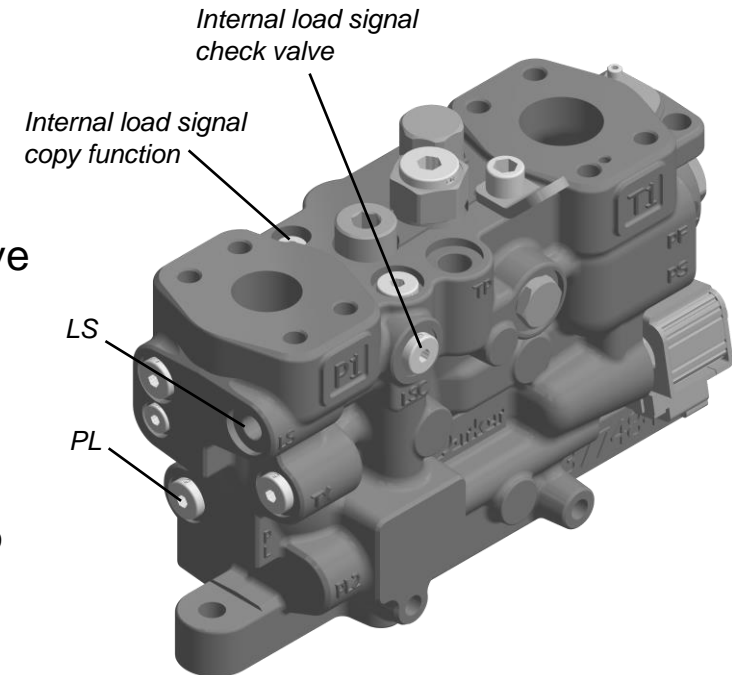

VA450 Inlet section

Functionality

- **Pilot pressure system**

- Pilot pressure supply function – Reduces pump pressure to a set level to ensure that there is enough pressure to supply the spool actuators. The reduced pressure can either be internally connected directly or via e.g., an external filter. Also includes:
 - A coarse filtration strainer.
 - A pressure relief valve to protect the pilot circuit.
 - An optional check valve to prevent oil from leaking back to pump.
- Pilot pressure supply blocking function – An electrically controlled safety function which makes it possible to block the connection between the reduced pilot pressure and work sections.

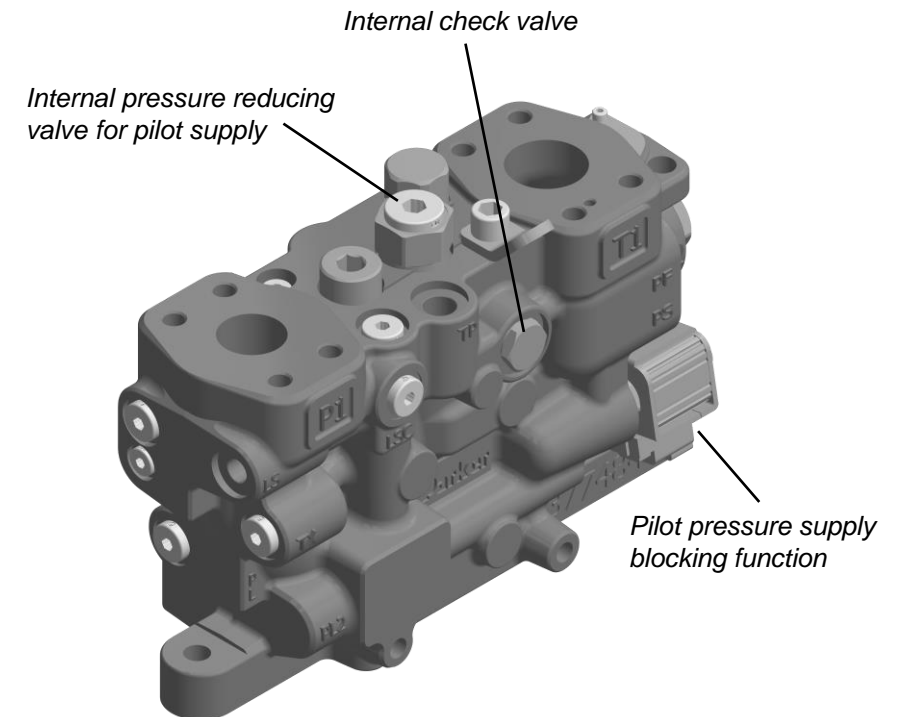

VA450 Inlet section

Functionality

- Pilot drain function – The pilot return can either be internally connected directly to the main tank or via a check valve to raise the pressure in pilot tank, or externally drained.
- Connection ports:
 - PF – Port for external use of the reduced pilot pressure. Can be connected to e.g., an external filter or remote-control valve.
 - PS – Pilot supply port.
 - TP – Pilot tank port for external drainage of pilot return.

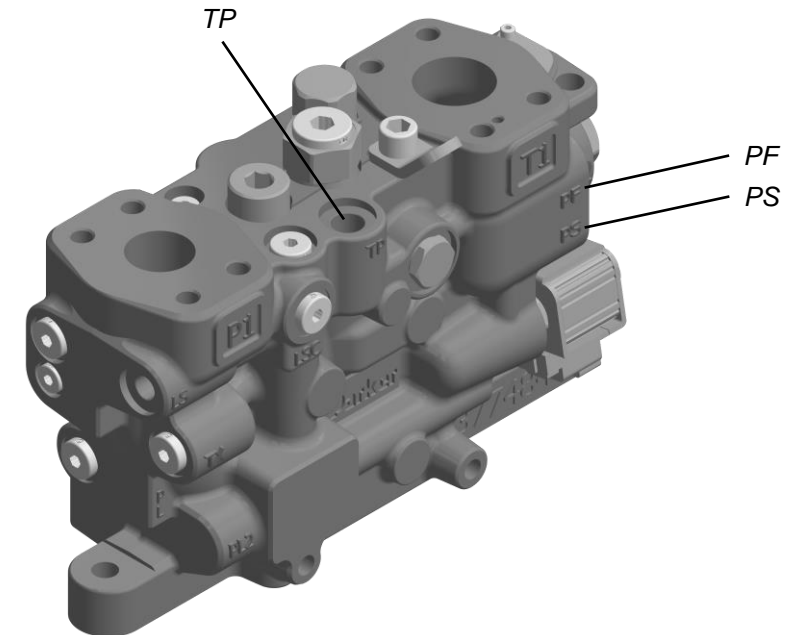

VA450 Work section

WS450

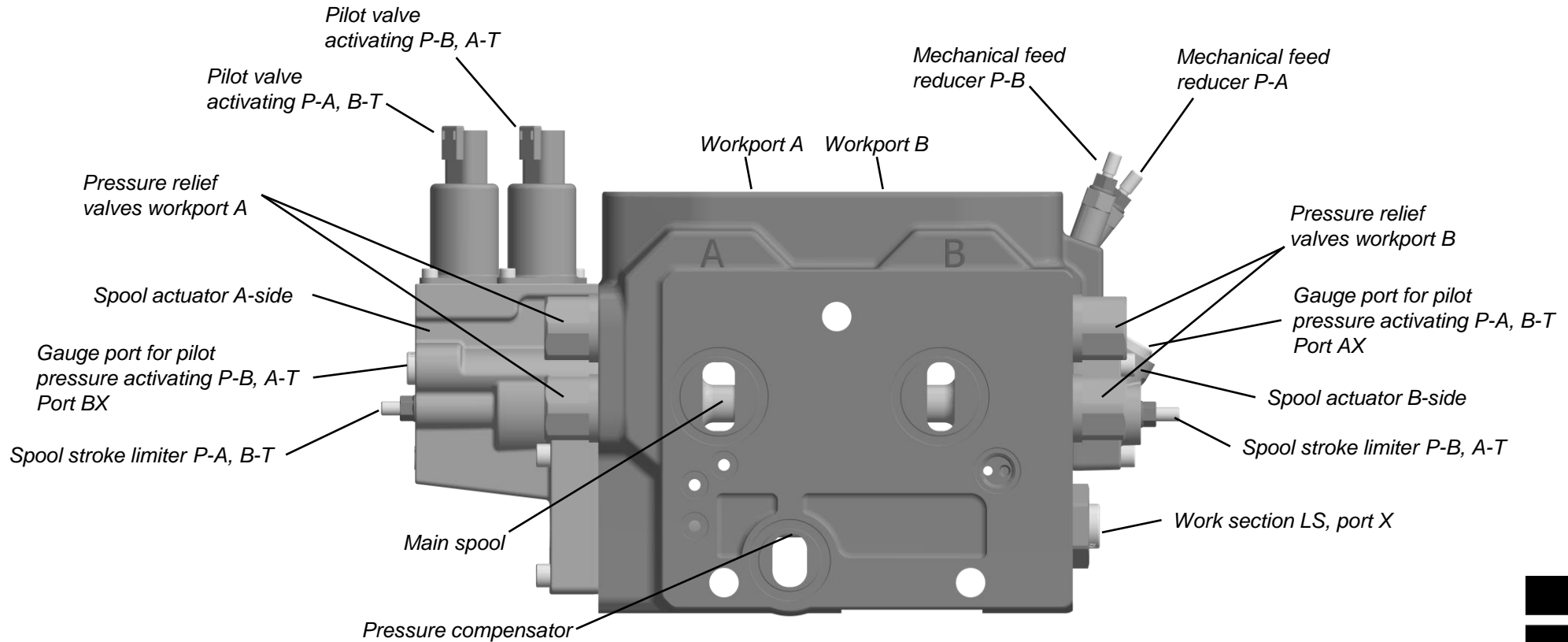

VA450 Work section

Functionality

- **Spool actuator A-side**

- EC – Electric proportional spool actuator controlled by two pilot valves. Supplied internally with pilot pressure oil.
- ECWP – Same as EC but with possibility to measure workport pressure in cap.
- PC – Hydraulic, proportional spool actuator controlled by external pilot pressure.

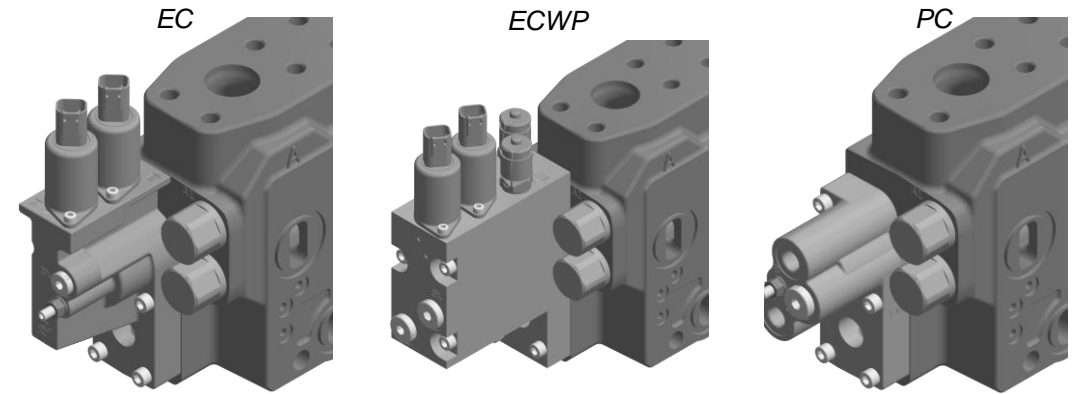

- **Spool actuator B-side**

- CAP – Standard cap.
- CH – Cap with lever control possibility.

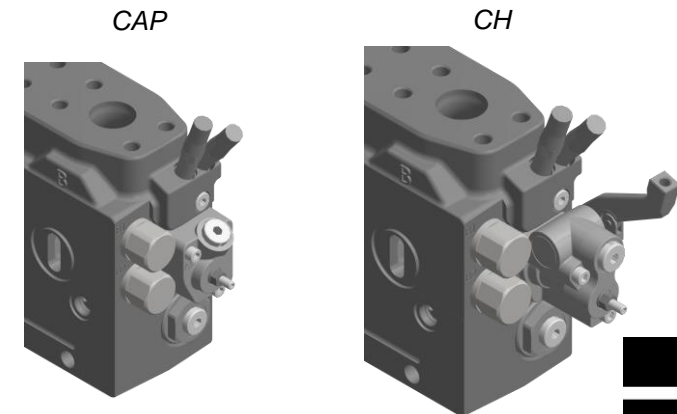

VA450 Work section

Functionality

- **Spool actuator related functions**

- Spool stroke limiters – Mechanically limit the spool stroke in either direction, adding flexibility in maximum flow to workport.
- Pilot signal damping – Dampens the pilot signal to provide a smoother start and stop of a function.
- Spool position sensor – Diagnostics of the spool's position.
 - Analog – Output signal proportional to the spool position.
 - Digital – ON/OFF output signal for indication when spool is inside/outside neutral position.
- Workport gauge ports – Measure workport pressure for valve diagnostics.

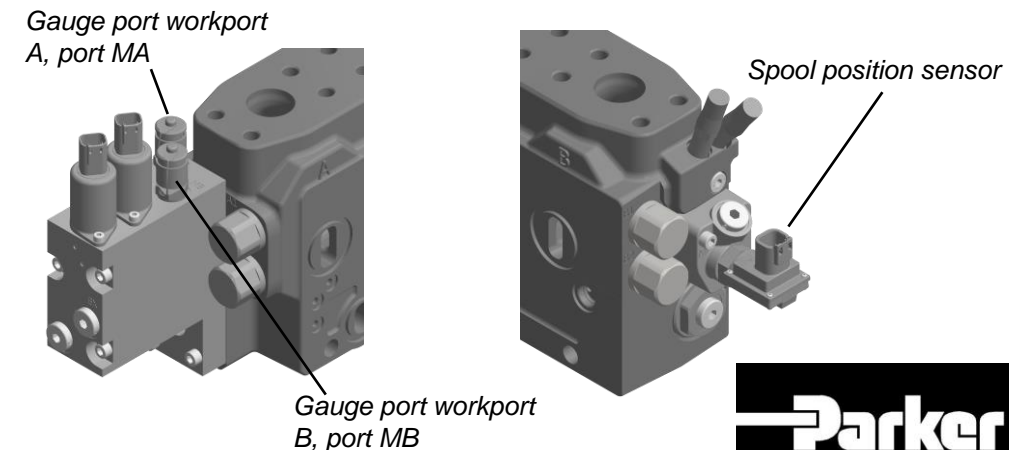
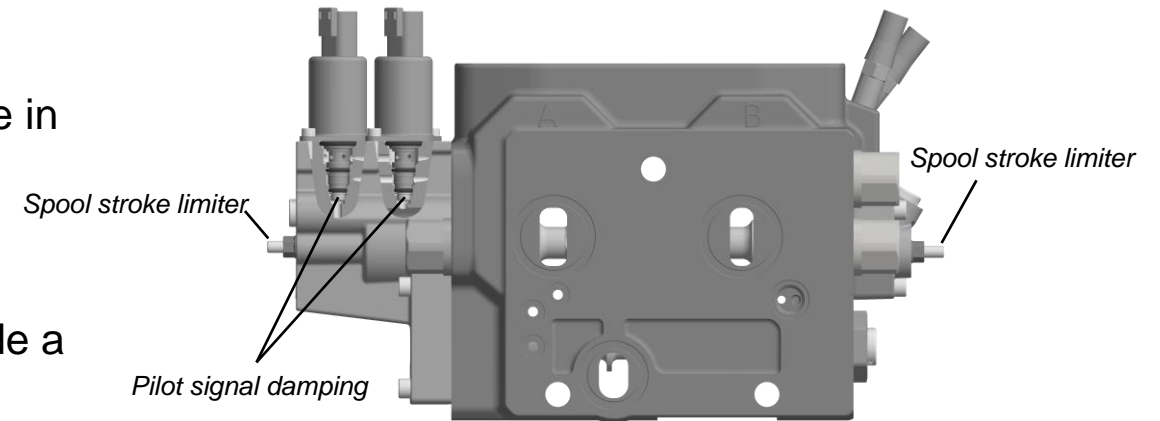

VA450 Work section

Functionality

- **Spool related functions**
 - Main spool – Function adapted main spools with pressure compensated flow rate up to 450 l/min.
 - Pressure compensator – Maintains constant speed of function regardless of the load and pressure variations in the system.
 - Integrated check valve to prevent oil from going back to pump in case of lower pressure in pump gallery.
 - Force feedback – Stabilizing effect on the hydraulic system providing a smoother operation when starting a high inertia load. The operator feels the increase/decrease in load pressure better.

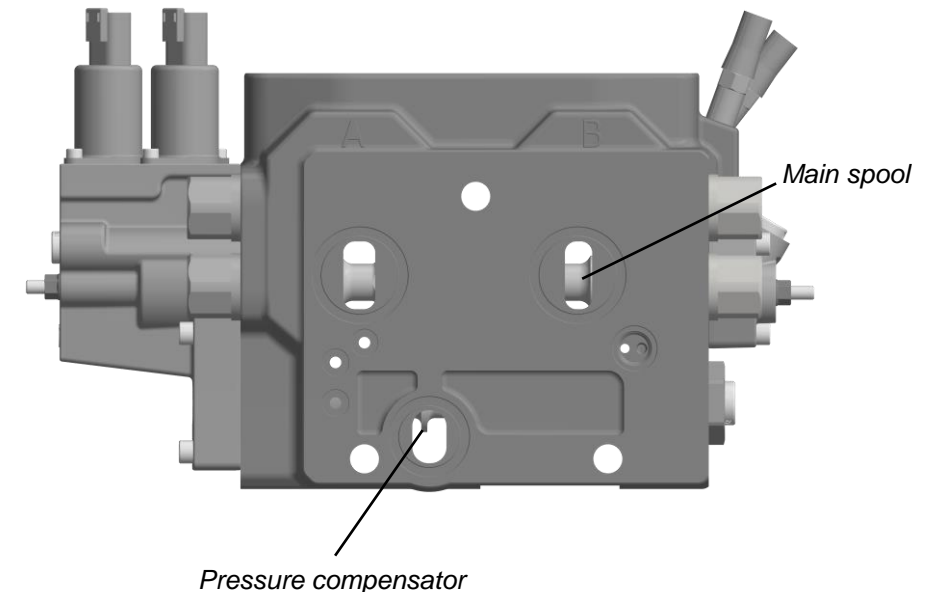

VA450 Work section

Functionality

- **Workport related functions**

- Mechanical feed reducers – Set maximum pressure in workport individually by limiting the load signal with low energy loss, consumes ~2 l/min.
- Electric proportional feed reducer – Control maximum pressure in workport proportionally up to 350 bar.
- Pressure relief valve in workports – Protects the workports and consumer from pressure peaks.
 - Integrated anti-cavitation function allowing workports to be refilled with tank oil in the event of negative pressure in workport, lowering the risk for cavitation.

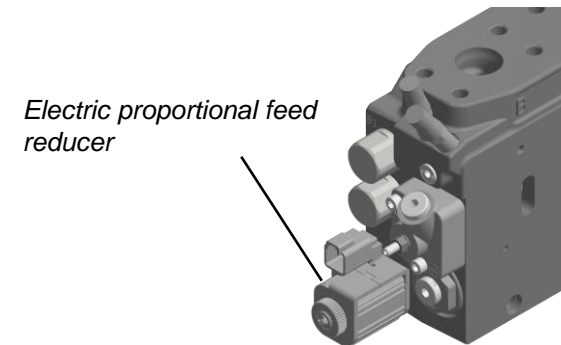
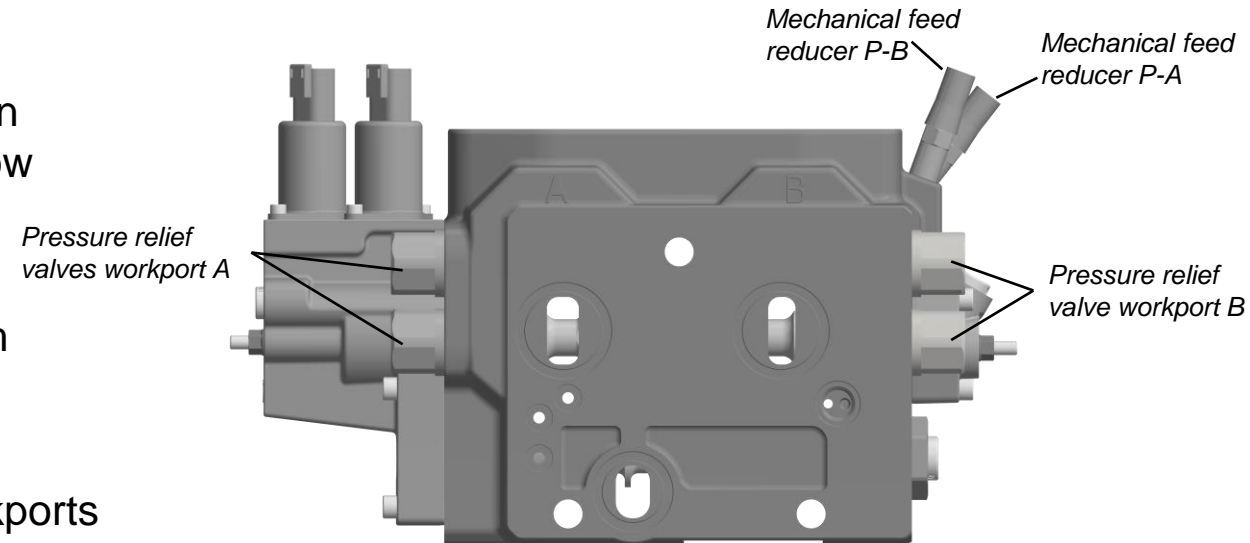

VA450 End section

US450

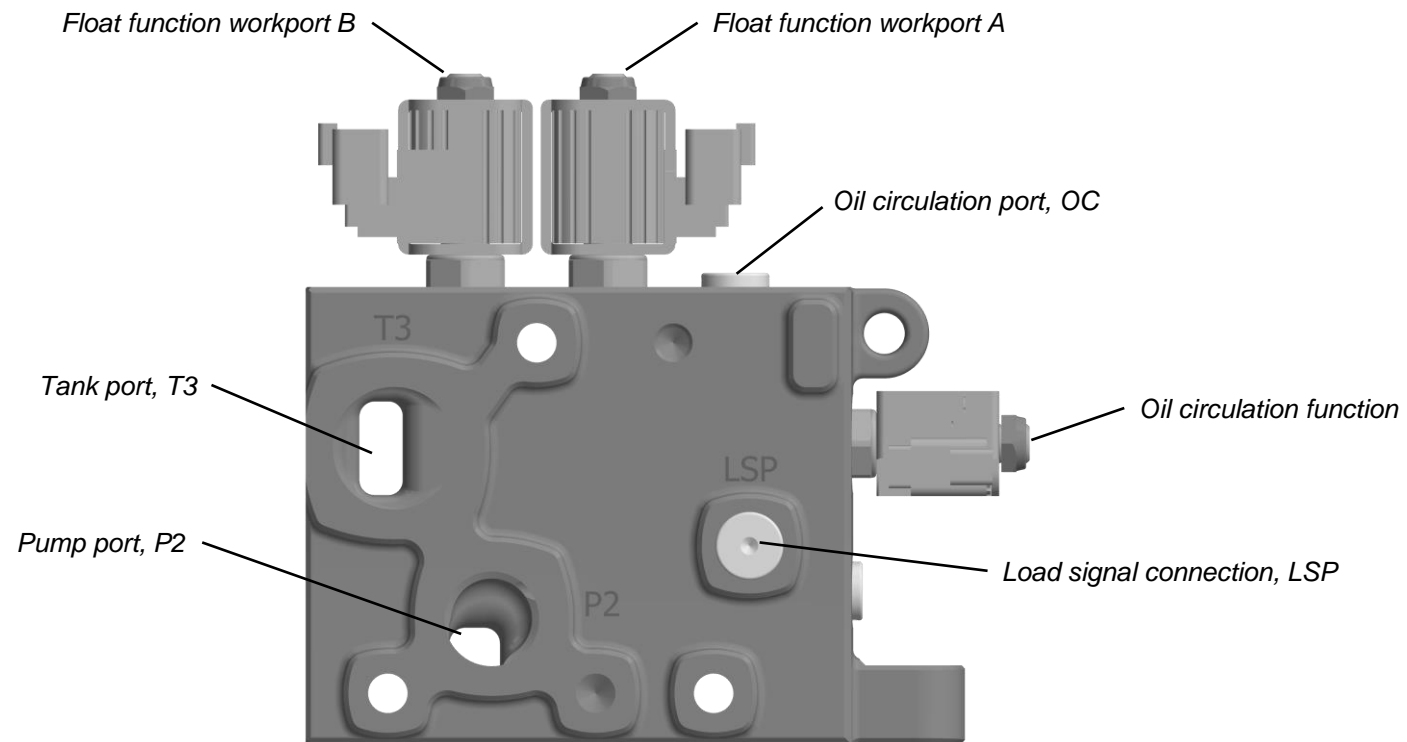

VA450 End section

Functionality

- **End section functions**

- Float function – Opens a connection between workports and tank to e.g., allow an implement to freely float on rough terrain.
- Oil circulation – Opens a connection from pump to either the tank gallery for internal circulation, or to port OC for external circulation. Can be used as e.g., a warmup-, cool down-, filtering-, or lubrication circuit.
- LSP port – Connection for the load signal from a parallelly connected valve.

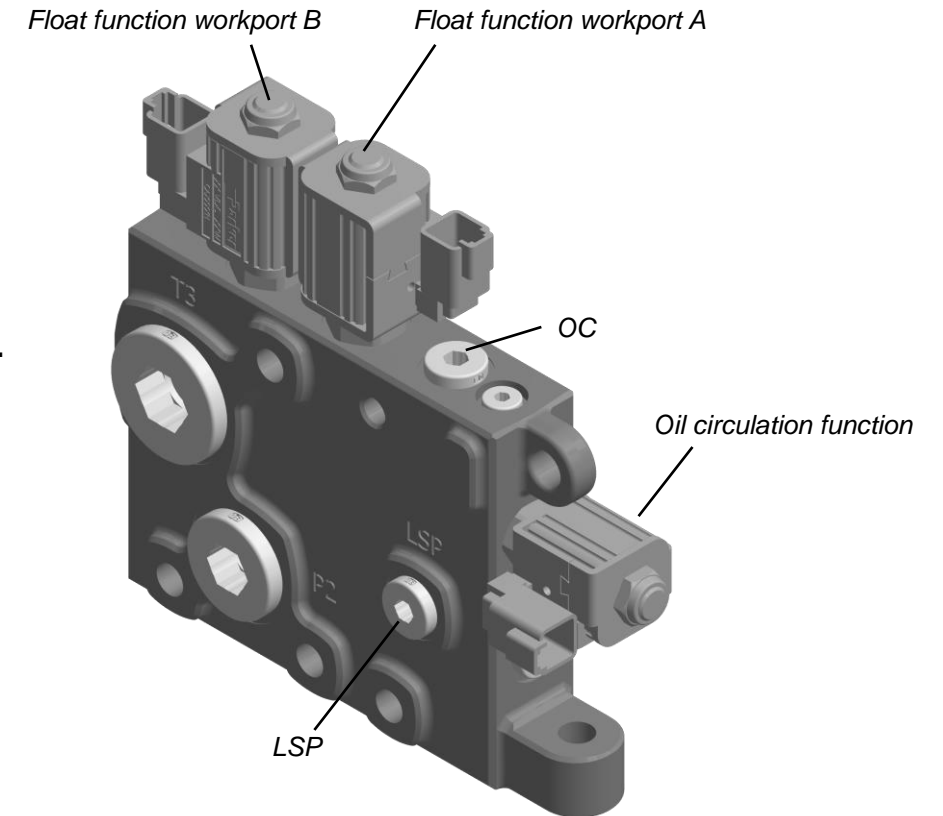

VA450 Manifold integration

- **Customer unique manifolds**

- Designed completely in accordance with the customer's specific needs regarding functionality, such as feed- and control functions for brake-, steering, suspension, cooling controls etc.
 - Consists of high-quality components from Parker's many divisions.
 - Neater and smarter packaging of functions reduces space claim and simplifies the hydraulic system.

VA450 Online configurator

- **Customer unique manifolds**

- Online configurator with all information for the unique valve available in one place:
 - Code report
 - Hydraulic schematics
 - Spare parts list
 - 3D-model
 - 2D-drawing
 - Learn More files for each function

The screenshot displays the eSYBER online configurator interface. The top navigation bar includes 'HOME', 'CREATE', and 'SEARCH'. The main content area is divided into 'CONTENT' and 'SCHEMATICS' tabs. The 'CONTENT' tab shows a list of components for 'VA300-08-064088, 01', including various functions like Hoist, Saw, Tilt, Stick, Clamp, Accumu, Level, and End Section. The 'SCHEMATICS' tab shows a detailed hydraulic schematic with various ports labeled (T2, PX, LS, LSC, PL, AX, B, A, P1, T1, TP, PF, PS, TX). To the right of the schematic is a 'Parker Valve Configuration VA300-08-064088-01' report. The report includes customer information (MSDE), system parameters (P1010, P1020, P1030, P1050), valve specifications (P1040, P1060, P1070), and a detailed list of components under 'Inlet section' and 'Pump and Tank ports'.

System			Valve		
Pos	Label	Code	Pos	Label	Code
P1010	Pump flow	360	P1040	Port connections	MJ
P1020	Pump pressure limited to (bar)	350	P1060	Surface treatment	P
P1030	Pump regulator setting (bar)	20	P1070	Type of nameplate	Std
P1050	System voltage	24			

Inlet section			Inlet section continued		
Pos	Label	Code	Pos	Label	Code
P2020	Port style	PT	Pilot pressure system		
P2010	Type of inlet	LS300	P2300	Pilot pressure supply	R
Pressure limitation			P2300S	Pressure level (bar)	35
P2030	Pressure relief	PA1	P2310	Check valve	RCV
P2030S	Setting (bar)	330	P2330	Filtration	X
P2170	Pressure relief tank	PAT	P2331	PX, External pilot filter port	C
P2170S	Setting (bar)	50	P2320	Pilot blocking function	X
Load signal system			P2341	PS, Pilot pressure port	C
P2050	Load signal copy function	KS	P2360	Pilot drain function	TP
P2250	LSC, Load signal port function	X	P2351	TP, Pilot tank port	O
Pump and Tank ports					
P2221	LS, Load signal port (copied)	O	P2101	P1, Pump port	O
P2201	PL, Load signal port	C	P2211	PX, Pump gauge port	C
			P2151	T1, Tank port	O

