



PM 3141-04

Service Parts Guide

Effective: February, 1996

PAVC SERIES VARIABLE VOLUME PISTON PUMP

Model PAVC 65 * * * * 13

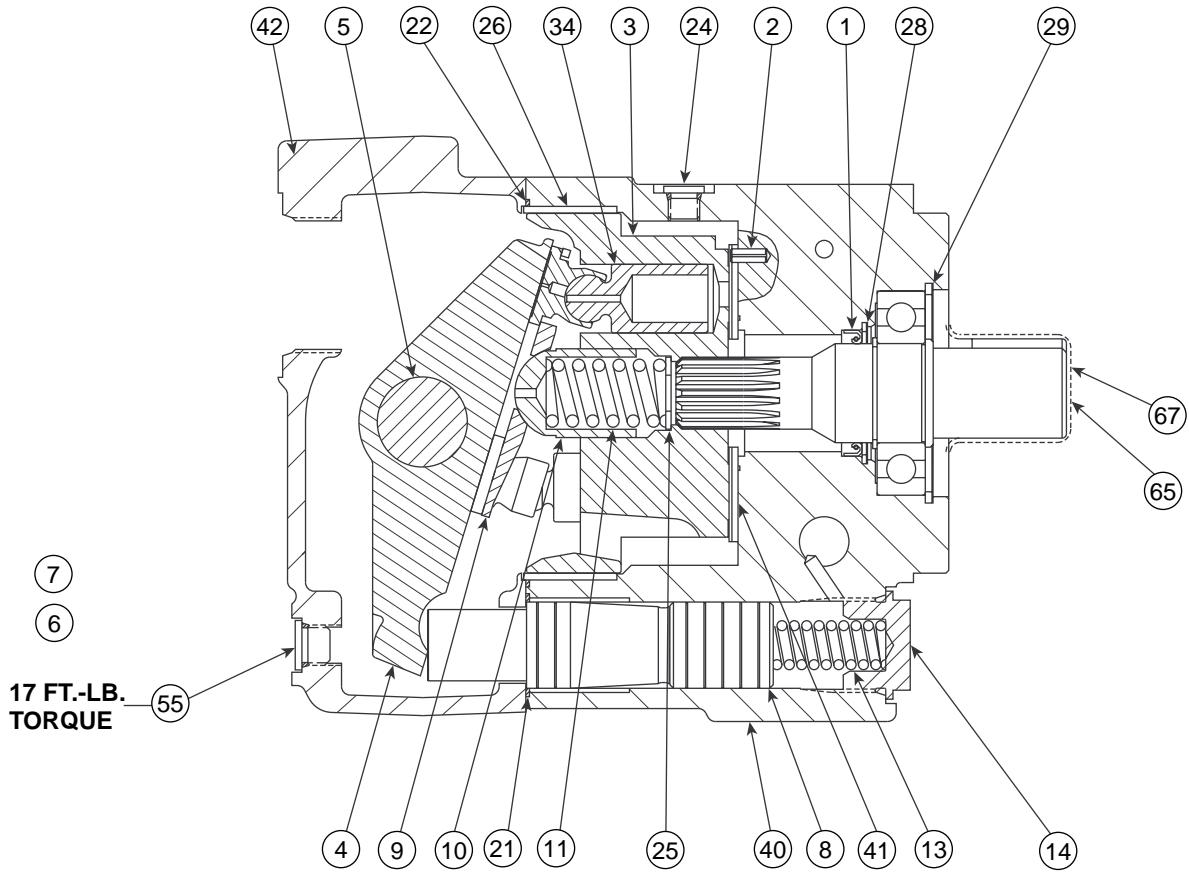

SECTION A-A

NOTE:
 Pump shown with Inlet
 Port Option 'Omit' (Rear Port)

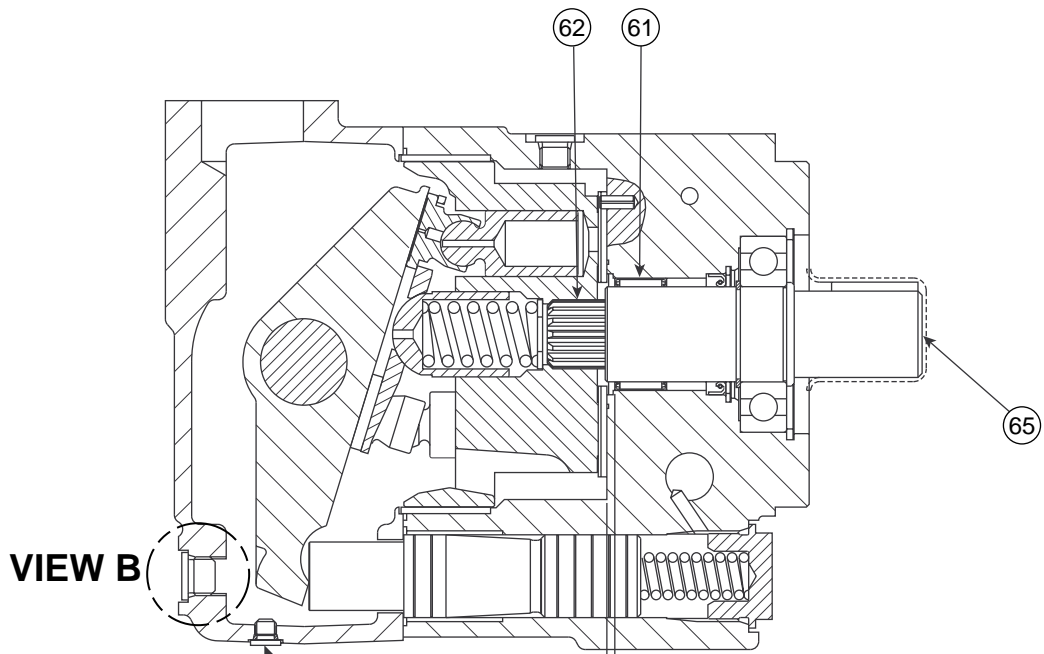

VIEW B

NOTE:
 Pump shown with Inlet
 Port Option '2' (Top Port)

\leftarrow \leftarrow **.070**
.090 **INSTALLED DEPTH OF NEEDLE**
BEARING, ITEM #61 BELOW
PORT PLATE FACE OF HOUSING

SECTION A-A

DUAL SHAFT BEARING
CONFIGURATION SHOWN (OPTION 9)

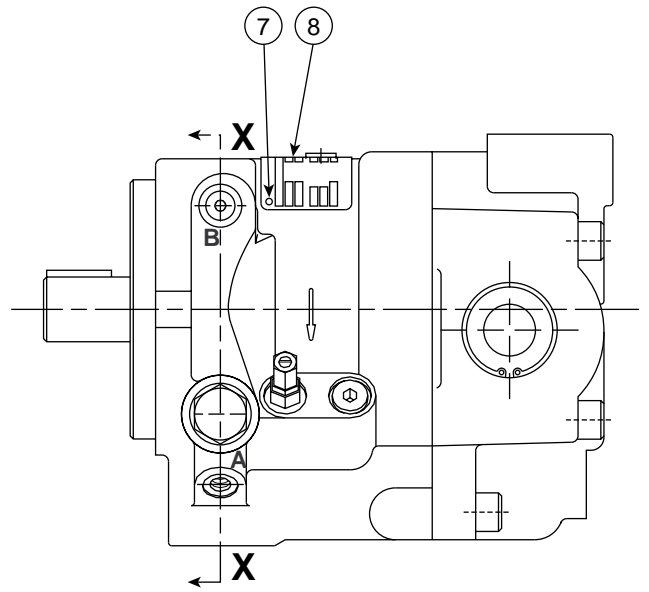
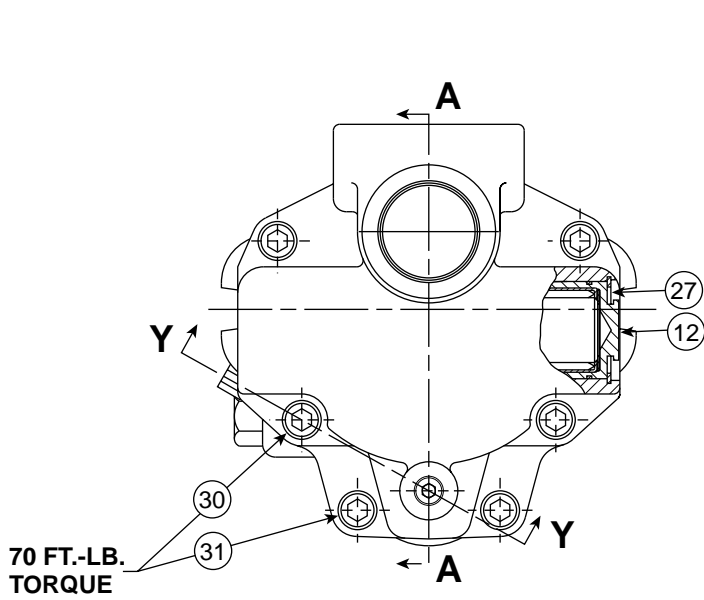

VIEW B

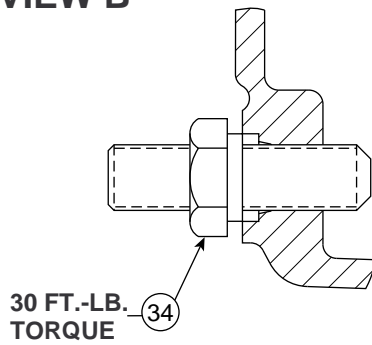

MAXIMUM VOLUME STOP VARIATION - 2

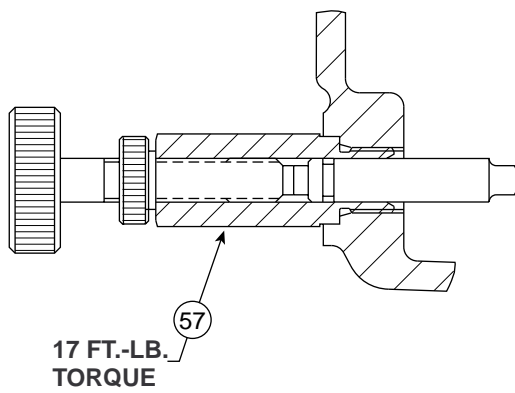

MAXIMUM VOLUME STOP VARIATION - 5

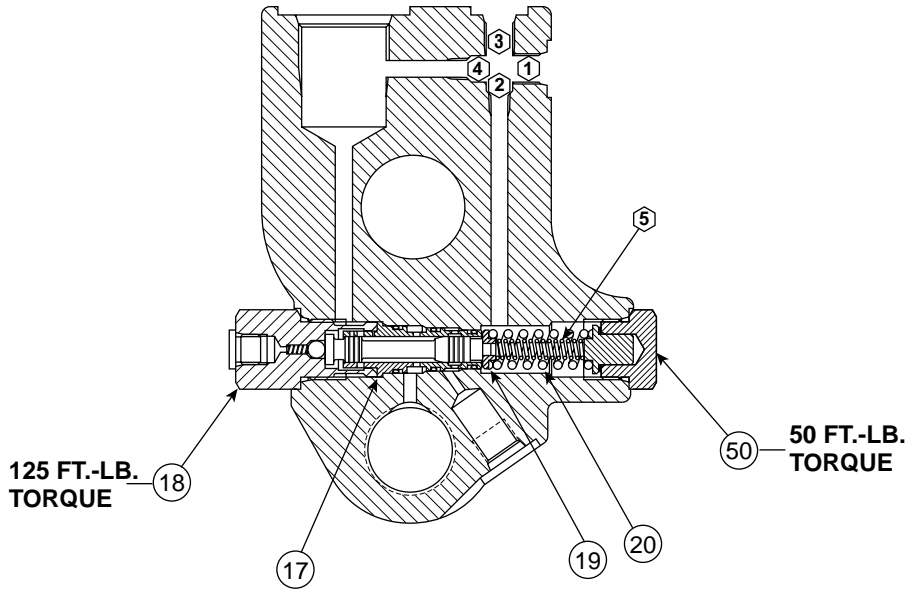

SECTION X-X
VARIATION "OMIT" NON-ADJ. DIFF.

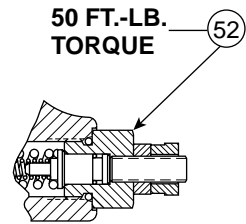

VARIATION "4"
ADJUSTABLE DIFFERENTIAL

CONTROL OPTION	POSITION				
	①	②	③	④	⑤
OMIT	OPEN	800599	108X4 ◊	108X4 ◊	OMIT
A	102X1	800599	OPEN	108X4 ◊	MA787474
C	102X1	800599	OPEN	108X4 ◊	MA787474
H	OPEN	800599	108X4 ◊	108X4 ◊	OMIT
M	800599	OPEN	OPEN	108X4 ◊	OMIT
ME	102X1	800599	OPEN	108X4 ◊	MA787474
S	800599	OPEN	OPEN	108X4 ◊	OMIT
SE	102X1	800599	OPEN	108X4 ◊	OMIT
AM	102X1	800599	786635 ◊	OPEN	MA787474
CM	102X1	800599	786635 ◊	OPEN	MA787474
HM	800599	OPEN	OPEN	108X4 ◊	OMIT

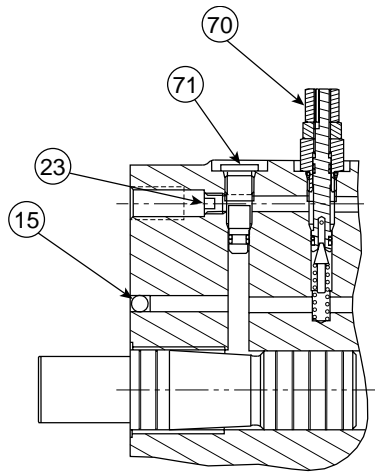

SECTION Y-Y

CONTROL OPTION OMIT
“A”, “M”, “ME”, & “AM”

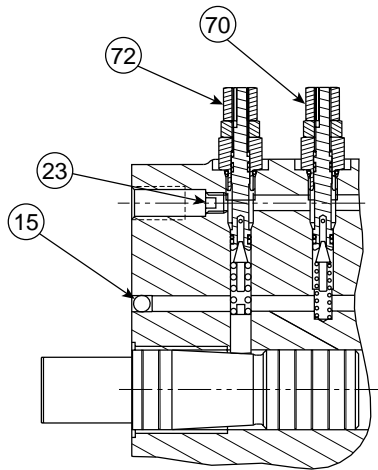

SECTION Y-Y

CONTROL OPTION
“C”, “H”, “CM”, & “HM”

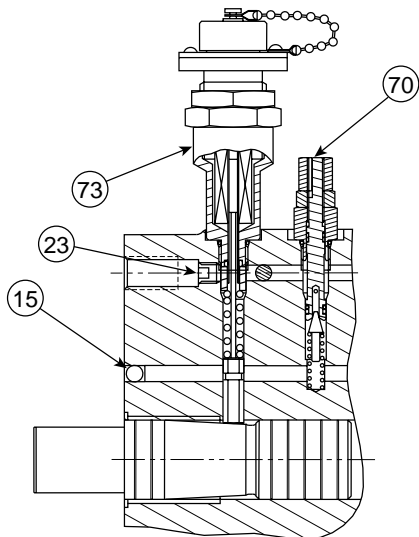

SECTION Y-Y

CONTROL OPTION
“S”, & “SE”

THESE ITEMS ARE SHOWN IN POSITION FOR CONTROL OPTION "OMIT" SEE SEPARATE DIAGRAM FOR OTHER CONTROL OPTIONS

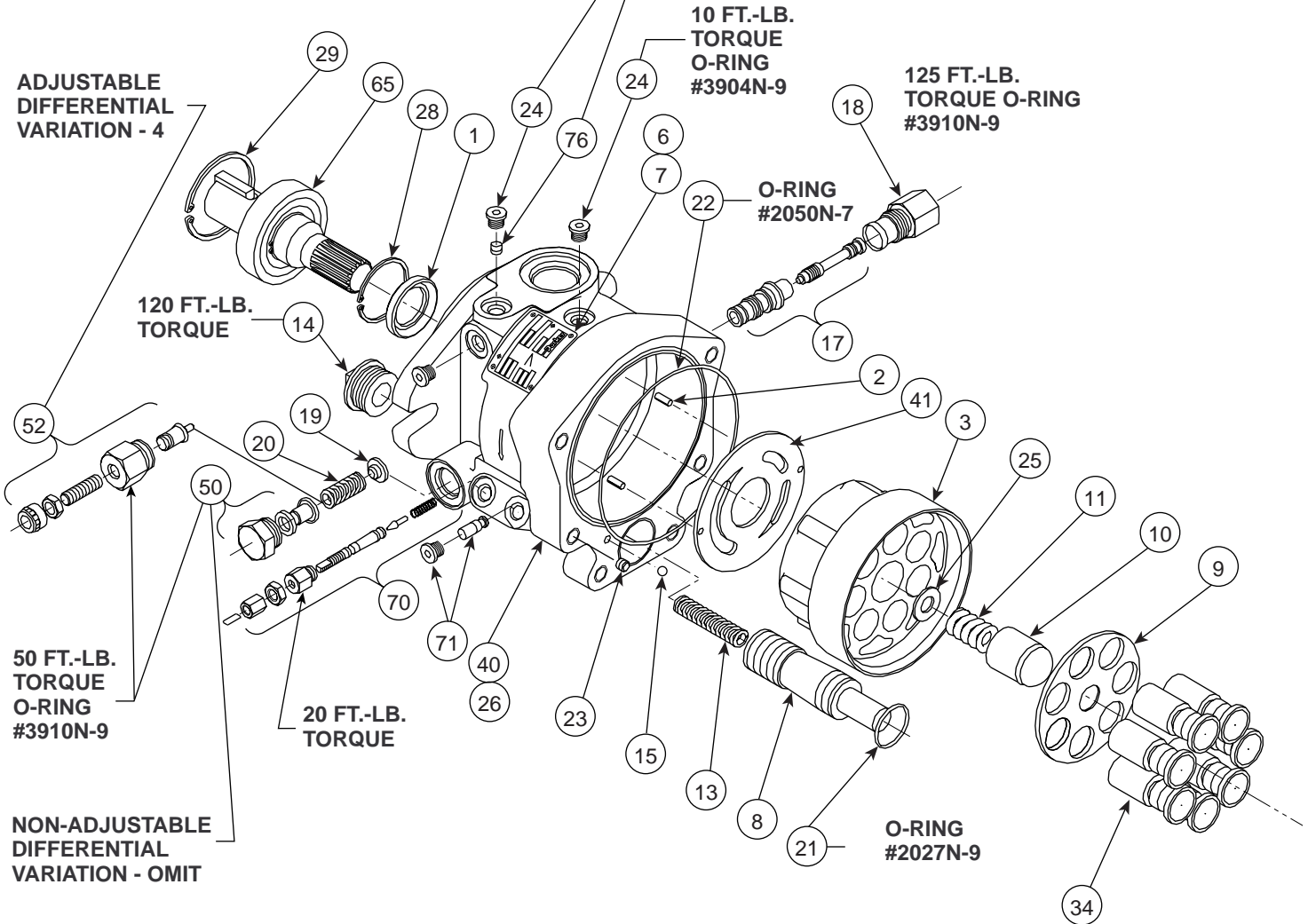

NOTES:

1. Pump shown is clockwise rotation, control option omit, and rear inlet port. For counter clockwise rotation outlet port, control drain and pump controls will be on opposite side.

2. Seal Kit P/N SKPAVC65** (** – Design Series).

3. Rotating Group Kit RRKPAVC65 ** (** – Design Series).

- R (CW)
- L (CCW)

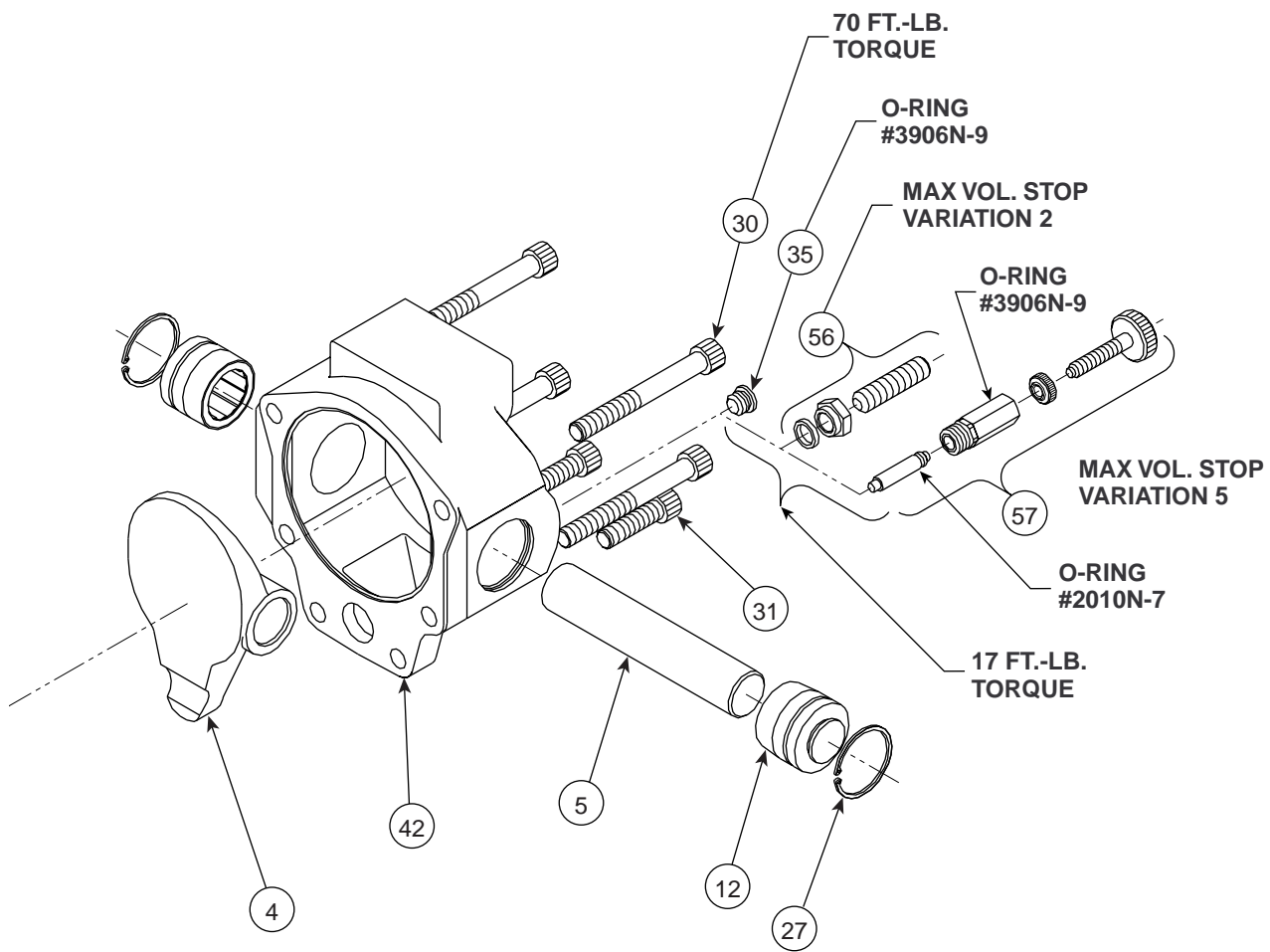

PAVC 65

	ITEM	PART NUMBER	QTY	DESCRIPTION
OMIT	1	787347	1	SHAFT SEAL
W	1	788029	1	SHAFT SEAL

	ITEM	PART NUMBER	QTY	DESCRIPTION
	2	99X81	2	ROLL PIN
	3	786293	1	BARREL
	4	786295	1	SWASH PLATE
P	5	786305	1	PIN-TRUNNION
	6	39X10	2	DRIVE SCREW
	7	800511	1	NAME PLATE
	8	786301	1	SERVO PISTON
A	9	786663	1	SLIPPER RETAINER
	10	786661	1	BALLSEAT
	11	787983	1	SPRING-BARREL
	12	787065 ○	2	TRUN. CAP ASS'Y.
V	13	786302	1	SPRING-SERVO
	14	787064 ○	1	PLUG-SERVO ASS'Y
	15	98X16	1	BALL
	16			
C	17	787056 ○	1	SPOOL & SLEEVE ASS'Y
	18	786946 ○	1	AIRBLEED ASS'Y
	19	786116	1	RETAINER-SPRING
	20	786113	1	SPRING-MOD.
6	21	2027○-9	1	O-RING
	22	2050○-7	1	O-RING
	23	102X1	1	PLUG
	24	108X4	1	PLUG
5	25	786393	1	RETAINER
	26	786888	1	BARREL-BUSHING
	27	56X325	2	SNAP RING
	28	56X352	1	SNAP RING
	29	56X337	1	SNAP RING
	30	10X301	4	CAP SCREW
	31	10X293	2	CAP SCREW
	32			
	33			
	34	787979	7	PISTON ASS'Y

O M I T	O	65	787598	1	SHFT ASS'Y-STR-1 PC	
		66				
		67	801111	1	PROTECTIVE CAP	
	B	65	787599	1	SHFT ASS'Y-SPL-1 PC	
9	O M I T	O	65	787577	1	SHFT ASS'Y-STR-2 PC
			66		1	
			67	801111	1	PROTECTIVE CAP
	B	65	787514	1	SHFT ASS'Y-SPL-2 PC	
		61	787351	1	NEEDLE BEARING	
	62	787469	1	IDLER SHAFT		

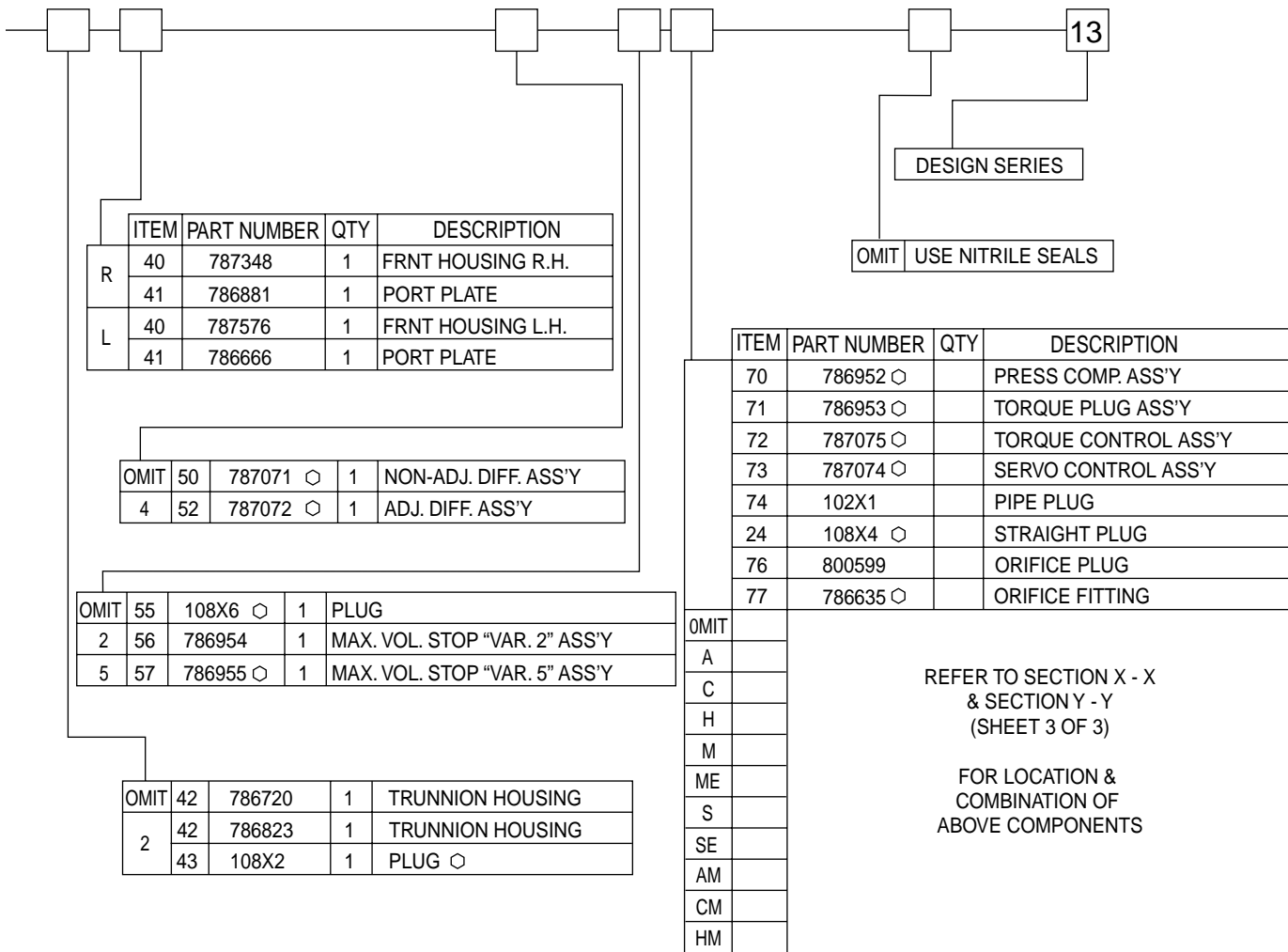

⚠ CAUTION

These service parts are intended for use in hydraulic pumps. Incorrect installation or assembly of these parts could cause the pump or pumps being repaired to fail in subsequent use, or to operate incorrectly.

The following precautions should be followed:

1. All parts should be cleaned and then lightly coated with mineral oil, or another lubricating fluid compatible with the system fluid being used, prior to assembly.
2. The pump should be disassembled, repaired, and reassembled in a clean environment.
3. Use proper tools to disassemble and reassemble the pump.
4. If you are uncertain as to how to install these parts, you should obtain assistance either from a Parker Hannifin distributor, or from the Fluidpower Pump Division.



Parker Hannifin Corporation
Hydraulic Pump/Motor Division
2745 Snapps Ferry Road
Greeneville, TN 37745 USA
Tel: (423) 639-8151
Fax: (423) 787-2418
Web site: www.parker.com/pumpmotor