

ENGINEERING **YOUR** SUCCESS.

PCH NETWORK PORTAL (PROFINET)

PCH1xNxxxx-Px



User Manual

Document Number: 1610PDN.02UM.00

Effective: Dec. 2020

© 2020 Parker Hannifin Corporation
All Rights Reserved.



Table of Contents

Table of Contents

	Page
CHAPTER - 1 General	5
1.1 Trademark Information.....	6
1.2 About this Guide.....	6
1.3 Safety Information.....	6
1.4 Important User Information.....	7
1.5 Intended Use.....	7
1.6 Service Information.....	7
1.7 Assumptions of Technical Experience.....	8
1.8 Product Naming.....	8
1.9 Notes, Cautions, and Warnings.....	8
CHAPTER - 2 Overview	9
2.1 Product Overview.....	10
2.2 Module Overview.....	11
2.3 Power Supply Connectors.....	12
2.4 Grounding.....	15
2.5 I/O and IO-Link.....	16
2.6 Status LEDs/Bluetooth Enable Button.....	19
2.7 USB connector and Rotary Switches:.....	21
2.8 Network Communication Ports NT1 and NT2.....	23
2.9 Connection to H Universal Air Supply.....	23
2.10 Port and Port LED Descriptions.....	27
2.11 IO Port LED Indication.....	28
CHAPTER - 3 Technical Data	29
3.1 Dimensions:.....	30
3.2 Mechanical Data.....	31
3.3 Operating Conditions.....	31
3.4 Electrical Data.....	31
CHAPTER - 4 PCH Portal Function	32
4.1 Slots and Module Description.....	33
4.1.1 Device Status and Control Module.....	34
4.1.2 Standard IO Module.....	35
4.1.3 Valve Module.....	35
4.1.4 IO-Link Modules.....	36
4.1.5 IO-Link IO Submodules.....	37
4.1.6 IO-Link Status Submodule.....	39
4.1.7 Extended Module.....	39

Table of Contents

4.2	Module Parameters	40
4.2.1	Port Configuration and Module Parametrization	40
4.2.2	Standard IO Module Parameters	41
4.2.3	Valve Module Parameters	44
4.2.4	IO-Link Module Parameters	47
4.3	Record Data Access	48
4.4	IO-Link Events	53
4.5	IO-Link Device parametrization	54
4.6	Protocol Dependent Functions	54
4.7	TIA Portal	54
4.7.1	Integration	55
4.7.2	Module Configuration	56
4.7.3	Module Parameters	56
CHAPTER - 5	Configuration Tool/Web Interface	59
5.1	The PC Configuration Tool/Web Interface	60
5.1.1	Status Screen	64
5.1.2	Port Configuration Screen	65
5.1.3	Pin Config	66
5.1.4	Digital Input Configuration Screen	67
5.1.5	Digital Output Configuration Screen	68
5.1.6	IO-Link Port Configuration Screen	69
5.1.7	IO-Link Events Screen	70
5.1.8	Valve Configuration Screen	71
5.1.9	IODD Configuration Screen :	72
5.1.10	Force Mode Screen	73
5.1.11	Help Screen	73
5.1.12	System Configuration Screen	74
5.1.13	Node Configuration Screen	75
5.1.14	Logs Screen	76
5.2	Bluetooth Mobile Application	77
CHAPTER - 6	Troubleshooting	78
6.1	Troubleshooting	79
CHAPTER - 7	Abbreviation List	87
7.1	Abbreviations	88
CHAPTER - 8	Appendix	89
8.1	IO-Link Events	90
8.1.1	IO-Link Event Qualifier:	90
8.1.2	IO-Link Event Codes	91
8.2	Power Consumption Chart	92

Table of Contents

8.3 Ordering Information 93

8.4 Connectivity and Integration Support 93

CHAPTER - 1 **General**

General

1.1 Trademark Information

PROFINET® is a registered trademark of PROFIBUS and PROFINET International (PI).

1.2 About this Guide

This user guide is intended for those who are responsible for installing, configuring, and troubleshooting PCH Portal and its associated software and accessories.

1.3 Safety Information

Please read and follow all the safety information for the Parker Communication for H-Series (PCH) Portal, including the warning and caution statements in this guide, before installing or operating the system.



WARNING: The PCH Portal is used to control electrical and mechanical components of motion control systems in industrial environments. To avoid serious injury or damage to equipment, test the motion system for safety under all potential conditions.



WARNING: The PCH Portal is not intended for any use in systems, machines, or applications where failure or fault of the Products could reasonably be seen to lead to death or serious bodily injury of any person, or to severe physical or environmental damage (“High-Risk Use”). You are not permitted to use, distribute, or sublicense the use of these Products in High-Risk use applications. High-Risk use is **STRICTLY PROHIBITED**.



WARNING: The PCH Portal contains no user-serviceable parts. To avoid personal injury or damage to the product, do not attempt to open the case or to replace any internal component of the PCH Portal, Modules, or Accessories.



WARNING: USER RESPONSIBILITY- Improper use of the products described herein or related items can cause death, personal injury and property damage.



CAUTION: Modification of endplate must always be done under the supervision of a Parker representative. If not, this may void any warranties.

1.4 Important User Information

This document and other information from Parker Hannifin Corporation, its subsidiaries or authorized distributors provides product or system options for further investigation by users having technical expertise.

The user, through their own analysis and testing, is solely responsible for making the final selection of the system and components and assuring that all performance, endurance, maintenance, safety and warning requirements of the application are met. The user must analyse all aspects of the application, follow applicable industry standards, and follow the information concerning the product in the current product catalogue and in any other materials provided from Parker, its subsidiaries, or authorized distributors.

To the extent that Parker, its subsidiaries, or authorized distributors provide component or system options based upon data or specifications provided by the user, the user is responsible for determining that such data and specifications are suitable for all applications and reasonably foreseeable uses of the components or systems.

1.5 Intended Use

The PCH Portal must be used as follows:

- As intended for industrial environments and conditions as compliant with the regulatory agencies of the region.
- In the original state without unauthorized modifications to the unit. The only permissible configurations and/or modifications allowed are mentioned in the documentation supplied with the product.
- In perfect technical condition.
- The PCH Portal has been developed and manufactured in accordance with the basic and proven safety principles of EN ISO 13849, LVD 2014/35/EU (low voltage directive) and EN61000-6-2 (Electromagnetic compatibility) and European Machinery Directive 2006/42/EC. The requirements of EN ISO 13849-1 and EN ISO 13849-2 must be taken into consideration to implement and operate the PCH Portal. When using this product in machines or systems subject to specific C standards, the requirements specified in these standards must be observed.
- This product is not CSA Certified. To conform to CSA C22.2 requirements please ensure the PCH Portal is connected to a class 2 power supply or equal as outlined in CSA Article 2.024 for low voltage equipment. The output of this power supply may not exceed 100 VA, with the operating voltage not more than 30 V rms, 42.4 V peak, or 60 V dc.

If standard accessories/components are connected (e.g., sensors, actuators, etc.) the specified limits of pressure, temperature, electrical data, torques, etc. must be complied with.

Even though care has been taken in the preparation and publication of the contents of this manual, we do not assume legal or other liability for any inaccuracy, mistake, misstatement, or any other error of whatsoever nature contained herein. The material in this manual is for information purposes only and is subject to change without notice.

1.6 Service Information

Consult the local Parker Service Agent if you have any technical problems or queries.

1.7 Assumptions of Technical Experience

Parker Hannifin Corporation assumes qualified personnel are involved in the servicing of industrial control systems and trained in recognizing hazards in products with hazardous energy levels. To install and troubleshoot the PCH Portal, the personnel must have a fundamental understanding of the following:

- Electronic concepts such as voltage, current, and switches
- Knowledge on the mechanical aspects of mounting the PCH Portal in the machine tool environment.
- Good understanding of the Networking concepts and implementation of safety circuitry

1.8 Product Naming

This guide describes the following product:

- PCH Portal

NOTE: For ordering information/part number structure, refer to 8.3

1.9 Notes, Cautions, and Warnings

This guide uses notes, cautions, and warnings throughout the text to draw attention to information that is especially important or useful.



WARNING: A warning provides information about a potential for property damage, personal injury, or death.



CAUTION: A caution provides information intended to help prevent improper use of the product or damage to the product hardware or software.

NOTE: A note provides information intended to make the best use of the product from Parker Hannifin Corporation.

CHAPTER - 2 **Overview**

2.1 Product Overview

The PCH Portal is a networked slave IO control device that supports multiple “Industrial Ethernet” communication protocols to communicate with other industrial controllers in the automation industry.

The PCH Portal is engineered to interface with a manifold containing up to 32 H ISO Universal valve channels as well as to offer a wide variety of discrete and IO-Link input/output arrangements for motion control, while withstanding the temperature ranges, vibrations, and electrical noise of industrial environments.



Figure 1 — PCH Portal

2.2 Module Overview

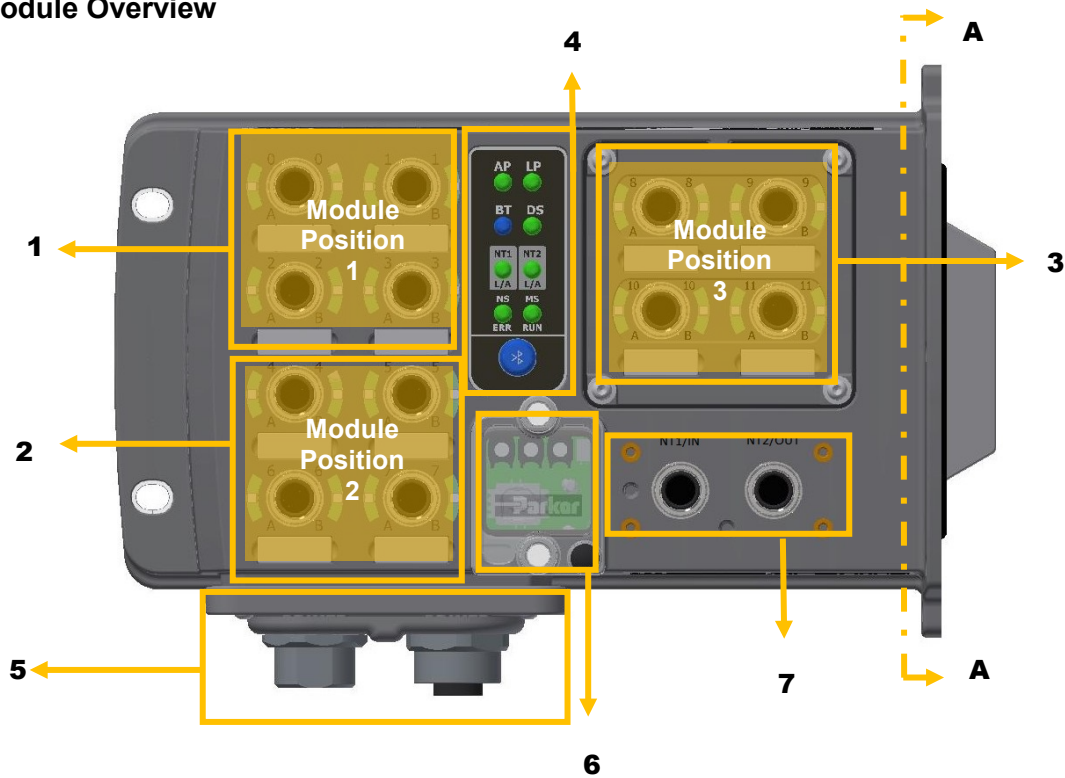

Figure 2 — Module Overview

Table 1 — Module Overview

Module Overview	
Item No	Part Name
1	Module Position 1 *
2	Module Position 2 *
3	Module Position 3 **
4	Status LEDs/Bluetooth enable button
5	Power Supply Connectors
6	Rotary Switches, USB connector (Type B)
7	Network Communication Ports – NT1 and NT2
A	Connection to H Universal Air Supply

NOTE:

* Possible options: “A” Module, “B” Module, “C” Module.

** Possible options: “A” Module, “B” Module, “C” Module, Blank Plate.

Overview

2.3 Power Supply Connectors

The Aux and Logic power connectors supply the power to all modules of the PCH Portal, the mother board and other modules.

The following four types of power connectors are available based on the end user's requirement. Power consumption requirements must be considered when selecting a power connection. When using the power out connector to supply downstream power, the total power consumption available for downstream devices is equal to maximum capacity of connector pins ($AUX_{PT} = 20A$ and $LOG_{PT} = 20A$) less the current draw of PCH. The PCH internal limits are as follows: $AUX_{PCH} = 12A$ and $LOG_{PCH} = 8A$. The PCH internal limits include devices connected to any of the 3 IO/IO-Link modules, and total wattage of the valve coils. Care must be taken in knowing the downstream current draw in order not to overload the maximum current rating of the pins. User can select 4-pin or 5-pin connectors configurations. Zone 1-3 is 24Vdc ,3.84A and Zone 4 is 24V, 1.28A.

NOTE: 5 pin connectors utilize pin 3 for protective earth ground.

Table 2 — Types of Aux Power Connectors

Type of Aux Power Connectors	Connector Pin	Connector Configuration	Description
A and B	4 Pin	IN OUT	4 Pin - A - Power IN - Power OUT
	5 Pin	IN OUT	5 Pin - B - Power IN - Power OUT
C and D	4 Pin	IN IN	4 Pin - C - Power IN - Power IN
	5 Pin	IN IN	5 Pin - D - Power IN - Power IN

Type 1: 4 Pin "A" (Power IN-Power OUT)

Table 3 — 4 Pin "A" (Power IN-Power OUT)

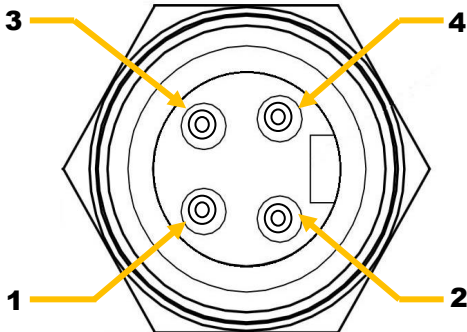
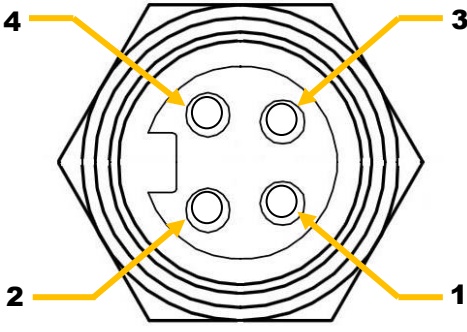
Power In (Male)			Power Out (Female)		
					
Pin	Function	Description	Function	Description	
1	+24 V	+24V V2 (VAUX)	+24 V	+24V V2 (VAUX)	
2	+24 V	+24V V1 (VLOG)	+24 V	+24V V1 (VLOG)	
3	0 V	GND V1 (VLOG)	0 V	GND V1 (VLOG)	
4	0 V	GND V2 (VAUX)	0 V	GND V2 (VAUX)	

Overview

Type 2: 5 Pin “B” (Power IN-Power OUT)

Table 4 — 5 Pin “B” (Power IN-Power OUT)

Power In (Male)			Power Out (Female)		
Pin	Function	Description	Pin	Function	Description
1	0 V	GND V2 (VAUX)	1	0 V	GND V2 (VAUX)
2	0 V	GND V1 (VLOG)	2	0 V	GND V1 (VLOG)
3	Protective Earth	Protective Earth	3	Protective Earth	Protective Earth
4	+24 V	+24V V1 (VLOG)	4	+24 V	+24V V1 (VLOG)
5	+24 V	+24V V2 (VAUX)	5	+24 V	+24V V2 (VAUX)

Type 3: 4 Pin “C” (Power IN-Power IN)

Table 5 — 4 Pin “C” (Power IN-Power IN)

Power In (Male)			Valve Power In (Male)		
Pin	Function	Description	Pin	Function	Description
1	+24V	+24V V2 (VAUX)	1	+24V	+24V V2 (VAUX) 1-3
2	+24V	+24V V1 (VLOG)	2	+24V	+24V V2 (VAUX) 4
3	0V	GND V1 (VLOG)	3	0V	Safe GND 1-3
4	0V	GND V2 (VAUX)	4	0V	Safe GND 4

Overview

Type 4: 5 Pin “D” (Power IN-Power IN)

Table 6 — 5 Pin “D” (Power IN-Power IN)

Power In (Male)			Valve Power In (Male)		
Pin	Function	Description		Function	Description
1	0V	GND V2 (VAUX)		+24V	+24V V2 (VAUX) 1-3
2	0V	GND V1 (VLOG)		+24V	+24V V2 (VAUX) 4
3	Protective Earth	Protective Earth		Protective Earth	Protective Earth
4	+24V	+24V V1 (VLOG)		0V	Safe GND 1-3
5	+24V	+24V V2 (VAUX)		0V	Safe GND 4

All four types of power connectors are capable of operating with SAFE pulsed power; however, it is recommended to use the 4 Pin C type and 5 Pin D type connector boards to connect SAFE 24Vdc auxiliary source in PP or PM mode for valve control as the grounds are isolated. The connection diagram is as shown below:

Overview

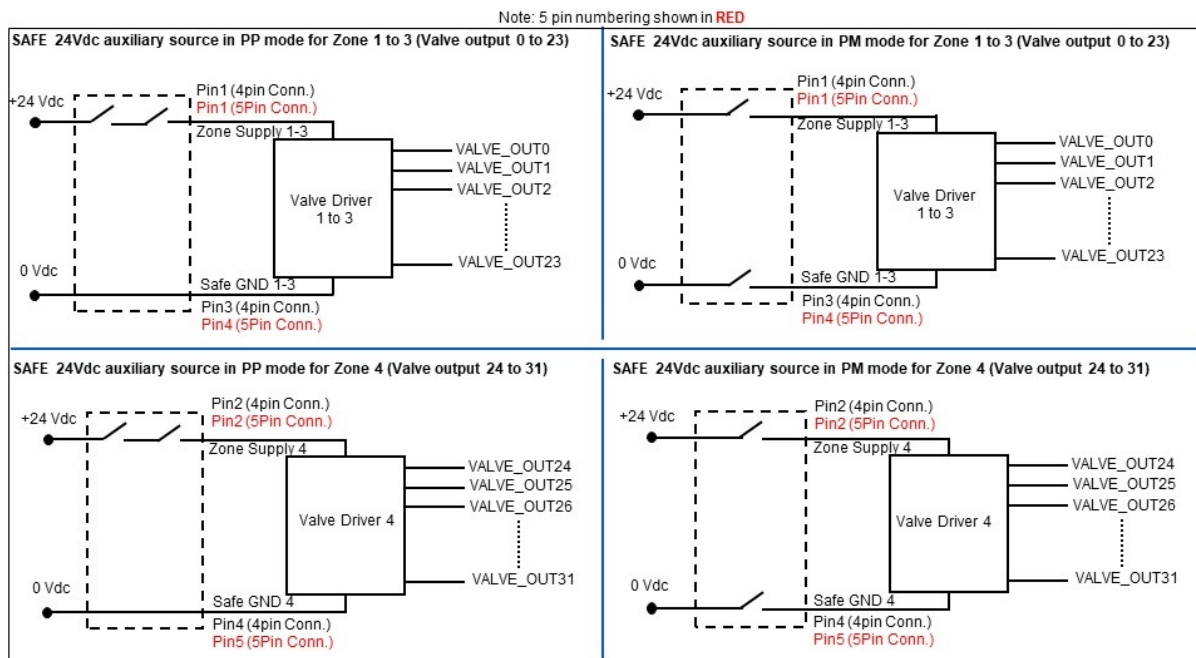

Figure 3 — C and D Board Wiring

NOTE:

The power back-up functionality (storing of cycle counts and error/warning/event log) of PCH Portal is not guaranteed to function if the PCH Portal is operated outside operating voltage range i.e., when the logic voltage is $\leq 20.4V$

If Aux voltage goes below the operating voltage range for the duration of 225 ± 25 msec then the valve outputs and aux voltage digital outputs are turned OFF for safety purpose. This behaviour is not applicable for A module as outputs on this module operate on logic supply.

To avoid unwanted motion in field a hysteresis of 200 mV is maintained to turn ON/OFF outputs in case of aux voltage error condition.

2.4 Grounding

The chassis ground is connected to the earth connection at the highlighted point below.



Figure 4 — Grounding Point

Overview

2.5 I/O and IO-Link

- **“A” Module (IO-Link Class A or configurable I/O):** This module has 4 M12 ports and is powered by Logic Power. Each port has the following configurations:
 - i. 1 IO-Link class A master and pin 2 configurable as input or output
OR
 - ii. 2 inputs, 24VDC (PNP or NPN)
OR
 - iii. 2 outputs (Logic Power), 250mA @ 24VDC

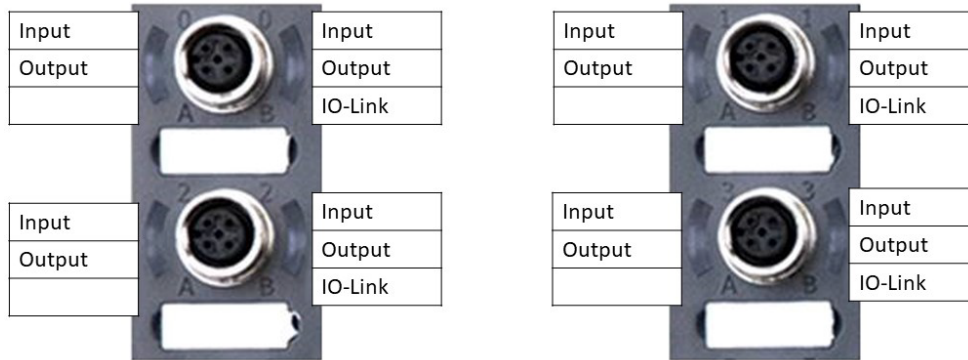

Figure 5 — “A” Module

Table 7 — “A” Module Port Details

Connector	Pin No.	Function
	1	+24V, 500mA VLOG (V1)
	2	Input (PNP or NPN)/Output +24V, 250 mA (V1)
	3	GND (V1)
	4	IO-Link/Input (PNP or NPN)/Output +24V, 250mA (V1)
	5	Not Connected

Overview

- “B” Module (IO-Link Class B or configurable I/O):** This module has 4 M12 ports. Each port has the following configurations:
 - IO-Link class B master
OR
 - 1 input, 24VDC (PNP or NPN), PIN 4
OR
 - 1 output (Logic Power), 250mA @ 24VDC, PIN 4

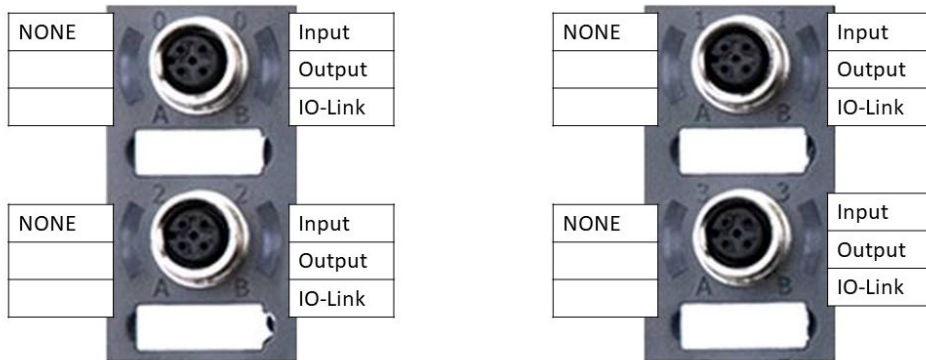

Figure 6 — “B” Module

Table 8 — “B” Module Port Details

Connector	Pin No.	Function
	1	+24V, 250mA VLOG (V1)
	2	+24V, 1.2A VAUX (V2)
	3	GND (V1)
	4	IO-Link/Input (PNP or NPN)/Output +24V, 250mA (V1)
	5	GND (V2)

Overview

- **“C” Module (IO-Link Class B or configurable I/O with Aux Outputs):** This module has 4 M12 ports. Each port has the following configurations:
 - i. 2 M12 ports with Digital Output.
 - a. 2 outputs (Aux Power), 500mA @ 24VDC
 - ii. 2 M12 ports with each port having the following configuration:
 - a. 1 IO-Link class B master
OR
 - b. 1 input, 24VDC (PNP or NPN), PIN 4
OR
 - c. 1 output (Logic Power), 250mA @ 24VDC, PIN 4

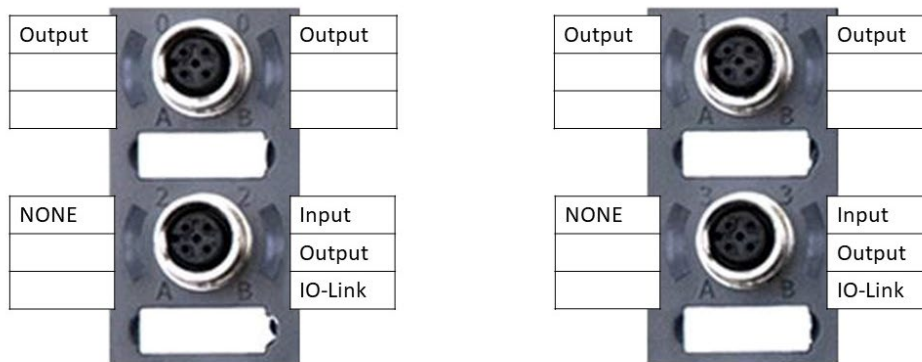

Figure 7 — “C” Module

Table 9 — “C” Module Aux Output Port Details (Port 0 and 1 of this Module)

Connector	Pin No.	Function
	1	Not Connected
	2	Output +24VAUX (V2), 500mA
	3	GND (V2)
	4	Output +24VAUX (V2), 500mA
	5	Not Connected

Table 10 — “C” Module IO-Link Class B Port Details (Port 2 and 3 of this Module)

Connector	Pin No.	Function
	1	+24V, 250mA VLOG (V1)
	2	+24V, 1.2A VAUX (V2)
	3	GND (V1)
	4	IO-Link/Input (PNP or NPN)/Output +24V, 250 mA (V1)
	5	GND (V2)

2.6 Status LEDs/Bluetooth Enable Button

Status LEDs: The LED's are used to indicate the status of Aux Power (AP), Logic Power (LP), Bluetooth Module Status (BT), Network Status (NS), Module Status (MS), Device Status (DS), Network Port 1 Link/Activity (NT1) and Network Port 2 Link/Activity (NT2).

Bluetooth Enables button: Press and hold this button for more than 3 seconds to enable/disable the Bluetooth functionality. The Bluetooth communication is used to connect to PCH Portal via Bluetooth mobile application and PC Configuration Tool (refer to CHAPTER - 5). To connect using PC Configuration Tool over Bluetooth, a low energy Bluetooth (BLE) USB Dongle must be connected to a USB port of Windows PC.



Figure 8 — Status LEDs/Bluetooth Enable button

The following table gives the status indication of the Aux Power, Logic Power, Bluetooth, Device and Network ports:

Table 11 — PCH Device LED Indication

LED Label	LED State	Indication	Description
Network Status (NS)	OFF	Offline	<ul style="list-style-type: none"> No power No connection with IO Controller
	Green	Online (RUN)	<ul style="list-style-type: none"> Connection with IO Controller established IO Controller in RUN state
	Green, 1 flash	Online (STOP)	<ul style="list-style-type: none"> Connection with IO Controller established IO Controller in STOP state or IO data bad IRT synchronization not finished
	Green, blinking	Blink	Used by engineering tools to identify the node on the network (Wink Functionality)
	Red	Fatal event	Major internal error (this indication is combined with a red module status LED)
	Red, 1 flash	Station Name error	Station Name not set
	Red, 2 flashes	IP Address error	IP address not set
	Red, 3 flashes	Configuration error	Expected Identification differs from Real Identification

Overview

LED Label	LED State	Indication	Description
Module Status (MS)	Off	Not Initialized	No power OR Module in SETUP or NW_INIT state.
	Green	Normal Operation	Module has shifted from the NW_INIT state.
	Green, 1 flash	Diagnostic Event(s)	Diagnostic event(s) present
	Red	Exception error	Device in state EXCEPTION.
Link/Activity LED for Ethernet Ports (NT1/IN, NT2/OUT)	OFF	NA	No link, No activity
	Solid Green	NA	100 Mbps link established
	Flashing Green	NA	100 Mbps Network Activity
Bluetooth (BT)	OFF	NA	Bluetooth communication OFF
	Solid Blue	NA	Bluetooth module is communicating with PC Utility over Bluetooth Interface
	Flashing Blue	NA	Bluetooth module is ON and waiting to be paired or Bluetooth module firmware upgrade in progress if Device status (DS) LED is flashing yellow
Auxiliary Power (AP)	Solid Red	NA	Auxiliary Power below 19.4 V or above 29.4V
	Flashing Red	NA	Auxiliary Power between 19.4V to 20.3V or 28.9V to 29.4V
	Solid Green	NA	Auxiliary Power between 20.4 V to 28.8V
	Solid Magenta	NA	Auxiliary Current above 12 Amps
Logic Power (LP)	OFF	NA	Logic Power below 16V or above 29.4V
	Solid Red	NA	Logic Power below 19.3V
	Flashing Red	NA	Logic Power between 19.4V to 20.3V or 28.9V to 29.4V
	Solid Green	NA	Logic Power between 20.4V to 28.8V
	Flashing Magenta	NA	Logic current between 7.5 Amps to 8 Amps
	Solid Magenta	NA	Logic current above 8 Amps
Device Status (DS)	Solid Green	NA	Device in normal mode
	Flashing Green	NA	Invalid IP Address
	Flashing Red	NA	Invalid product code/Valve short circuit
	Solid Red	NA	Internal error
	Solid Yellow	NA	internal warning
	Solid Magenta	NA	Module Error
	Flashing Magenta	NA	Internal warning
	Flashing Cyan	NA	Temperature between 75 °C to 80 °C/Reset to default in progress
	Solid Cyan	NA	Temperature above 80 °C

Overview

2.7 USB connector and Rotary Switches:

USB Connector: The USB 2.0 OTG, Type-B standard connector is used to interface with the configuration software. The configuration software is used to configure and monitor the PCH Portal product.

Rotary Switches: PCH Portal contains 3 rotary switches. These are used to set the Factory Default, Static IP, Enable FTP and DHCP mode. Refer Table 13 for details.

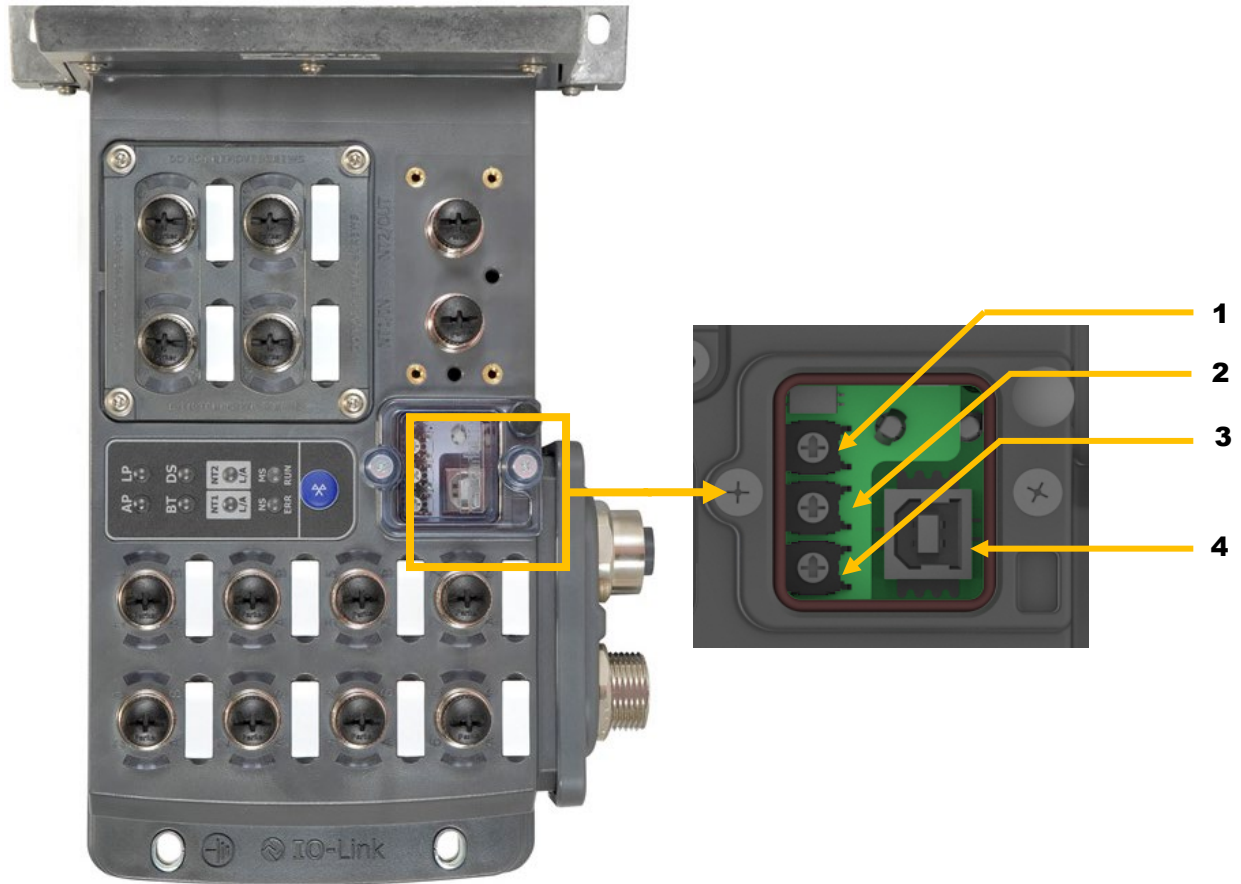

Figure 9 — USB Port and Rotary Switch Details

Table 12 — USB Port and Rotary Switch Details

Callout No.	Details
1	Rotary Switch x1
2	Rotary Switch x10
3	Rotary Switch x100
4	USB Port

Overview

The rotary switches are housed besides the USB port. The rotary switches are used to configure the PCH Portal for the following functionalities based on the rotary switch settings shown in Table 13.

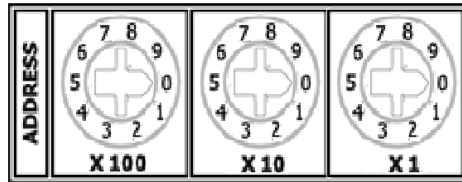

Figure 10 — Rotary Switch Configuration Details

Table 13 — Rotary Switch Settings

Rotary Switch Setting	Description
333	A setting of 333 on the rotary switch and power cycle of the PCH device will allow the config utility over USB and web interface to configure all the four octets of IP address of the PCH Portal. After IP address configuration through utility, power cycle PCH Portal so that it boot-up with IP address configured using the config tool.
387	A setting of 387 on the rotary switch and power cycle of the PCH device will Enable the FTP.
888	A setting of 888 on the rotary switch and power cycle of the PCH Portal will configure PCH Portal to use IP address assigned by DHCP server.
999	A setting of 999 on the rotary switch and power cycle of the PCH Portal will reset PCH Portal to default setting.

NOTE:

The Rotary Switch setting mentioned in the above table are special settings values and are not typically used for configuring the IP address. In most cases the IP address of the device is configured through DCP Protocol using a PROFINET Master or PROFINET Network configurator.

Table 15 — Valve Output Pinout Details

Connector	Pin Number	Function
	1	GND V2/Safe GND 1
	2	GND V2/Safe GND 1
	3	GND V2/Safe GND 1
	4	GND V2/Safe GND 1
	5	GND V2/Safe GND 1
	6	Protective Earth
	7	VALVE_OUT0
	8	VALVE_OUT1
	9	VALVE_OUT2
	10	VALVE_OUT3
	11	VALVE_OUT4
	12	VALVE_OUT5
	13	VALVE_OUT6
	14	VALVE_OUT7
	15	VALVE_OUT8
	16	VALVE_OUT9
	17	VALVE_OUT10
	18	VALVE_OUT11
	19	VALVE_OUT12
	20	VALVE_OUT13
	21	VALVE_OUT14
	22	VALVE_OUT15
	23	VALVE_OUT16
	24	VALVE_OUT17
	25	VALVE_OUT18
	26	VALVE_OUT19
	27	VALVE_OUT20
	28	VALVE_OUT21
	29	VALVE_OUT22
	30	VALVE_OUT23

Table 16 — Valve Output Pinout Details

Connector	Pin Number	Function
	1	GND V2/Safe GND 2
	2	GND V2/Safe GND 2
	3	VALVE_OUT24
	4	VALVE_OUT25
	5	VALVE_OUT26
	6	VALVE_OUT27
	7	VALVE_OUT28
	8	VALVE_OUT29
	9	VALVE_OUT30
	10	VALVE_OUT31

NOTE: The valve outputs operate on aux voltage and have latching behaviour. In case the logic voltage drops below operating range (< 16 V or > 30V), the valve outputs remain latched to the state they were set to when the PCH Portal logic supply was in operating range.

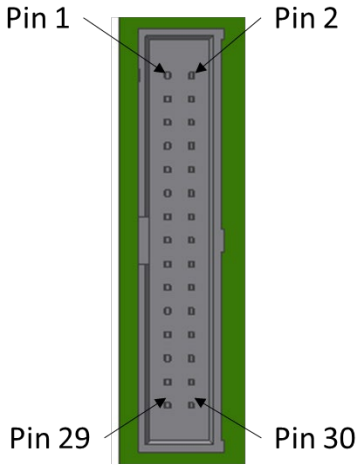
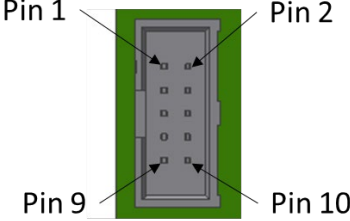

CAUTION: To comply with the protection class IP65, seal the unused ports with the appropriate plugs or cover caps.

Overview

- The PCH Network Portal can use the following H ISO Universal Valves:
 - ISO 15407-2 – sizes 02 & 01
 - ISO 5599-2 – sizes 1, 2 & 3
- The PCH Network Portal can support up to 32 addresses as shown
- The data map and PCH Tool refers to each address with a Valve_X designator. Each Valve_X designator is as shown.
- Addresses 25-31 can be accessed using an Intermediate Air Supply with Electric Expansion
- Each address is one solenoid

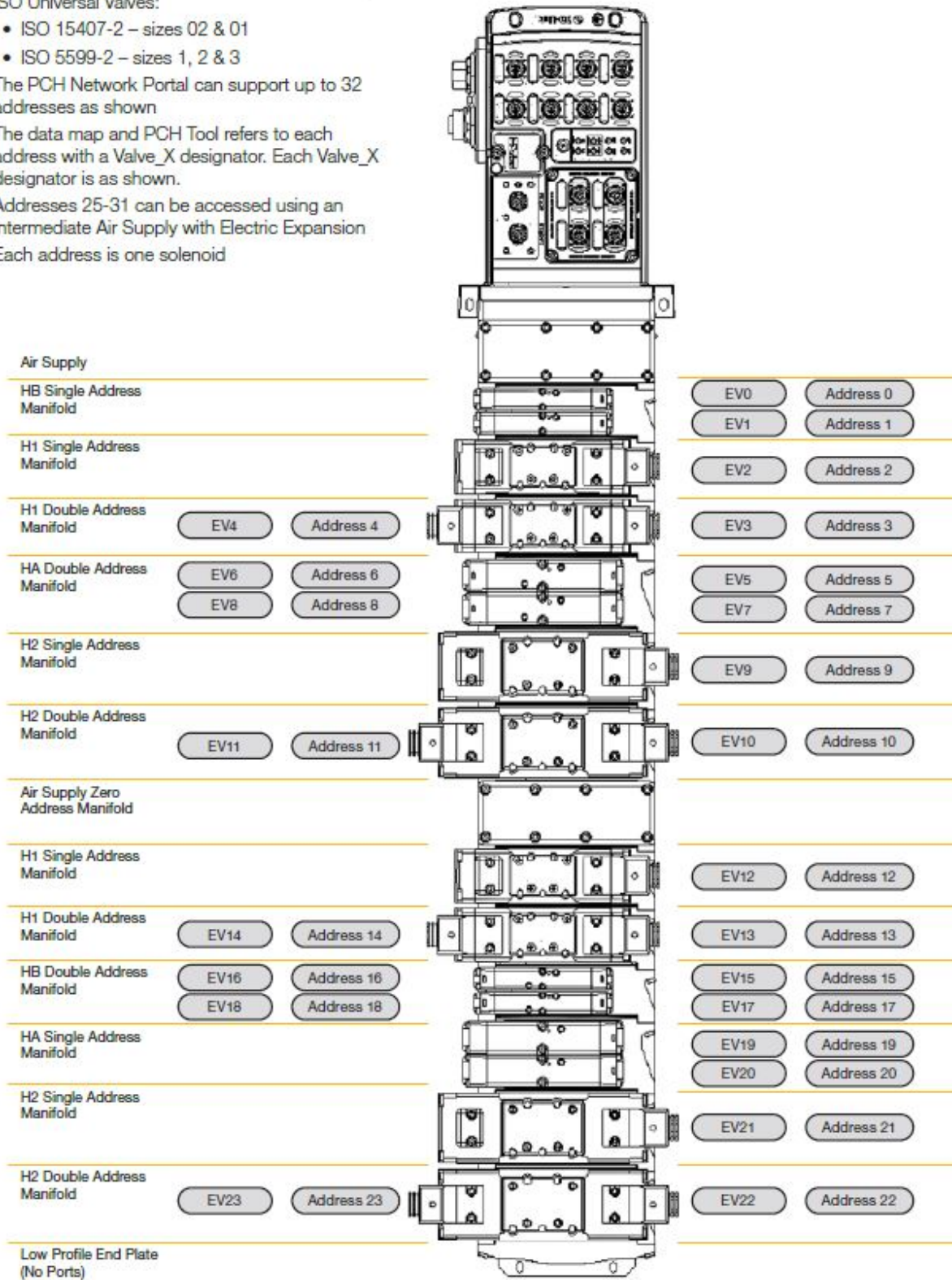

Figure 12 — Solenoid addressing

Overview

2.10 Port and Port LED Descriptions

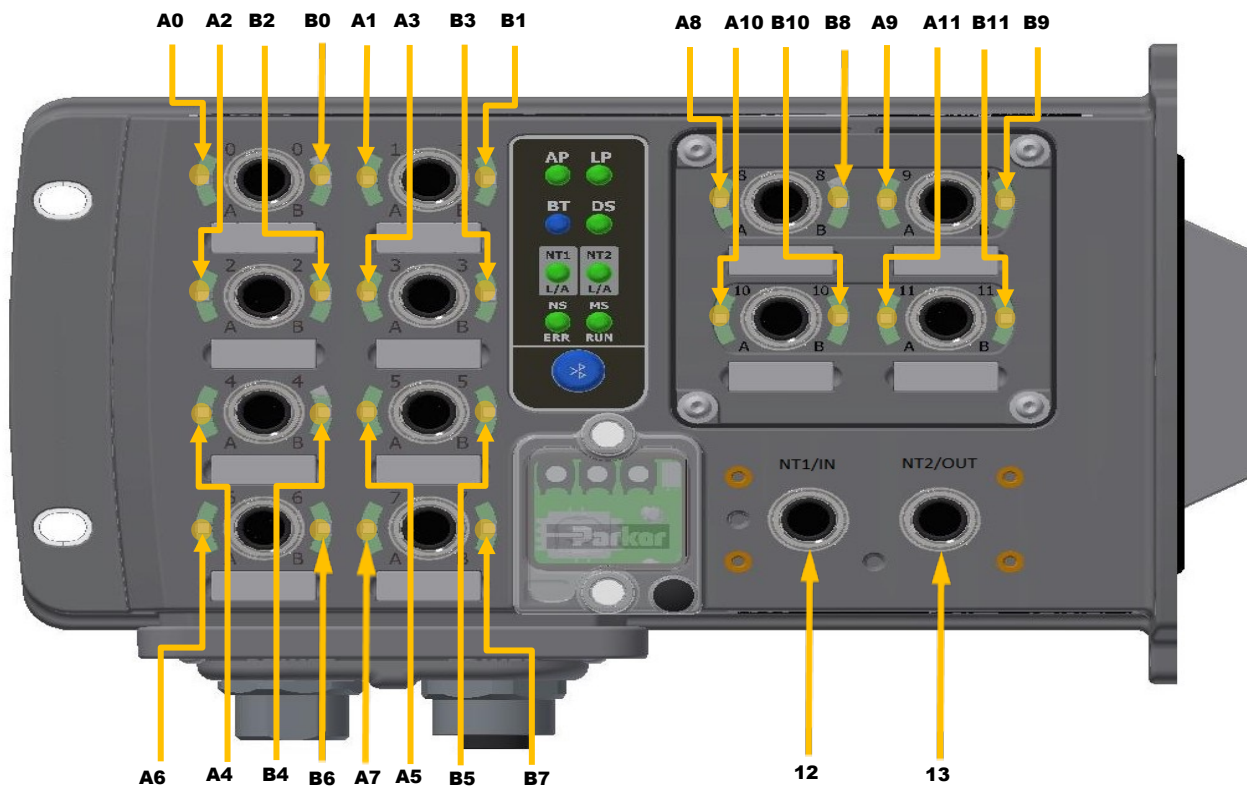

Figure 13 — Port Description

Table 17 — Port Description

Port Description		Port Description	
Callout No.	Port Number	Callout No.	Port Number
A0 (Channel 0)	Port 0/A (Pin 2)	B6 (Channel 13)	Port 6/B (Pin 4)
B0 (Channel 1)	Port 0/B (Pin 4)	A7 (Channel 14)	Port 7/A (Pin 2)
A1 (Channel 2)	Port 1/A (Pin 2)	B7 (Channel 15)	Port 7/B (Pin 4)
B1 (Channel 3)	Port 1/B (Pin 4)	A8 (Channel 16)	Port 8/A (Pin 2)
A2 (Channel 4)	Port 2/A (Pin 2)	B8 (Channel 17)	Port 8/B (Pin 4)
B2 (Channel 5)	Port 2/B (Pin 4)	A9 (Channel 18)	Port 9/A (Pin 2)
A3 (Channel 6)	Port 3/A (Pin 2)	B9 (Channel 19)	Port 9/B (Pin 4)
B3 (Channel 7)	Port 3/B (Pin 4)	A10 (Channel 20)	Port 10/A (Pin 2)
A4 (Channel 8)	Port 4/A (Pin 2)	B10 (Channel 21)	Port 10/B (Pin 4)
B4 (Channel 9)	Port 4/B (Pin 4)	A11 (Channel 22)	Port 11/A (Pin 2)
A5 (Channel 10)	Port 5/A (Pin 2)	B11 (Channel 23)	Port 11/B (Pin 4)
B5 (Channel 11)	Port 5/B (Pin 4)	12	Ethernet Port 1 (NT1)
A6 (Channel 12)	Port 6/A (Pin 2)	13	Ethernet Port 2 (NT2)

Overview

2.11 IO Port LED Indication

Each of the Ports have two LEDs to indicate the I/O-States that are configured.

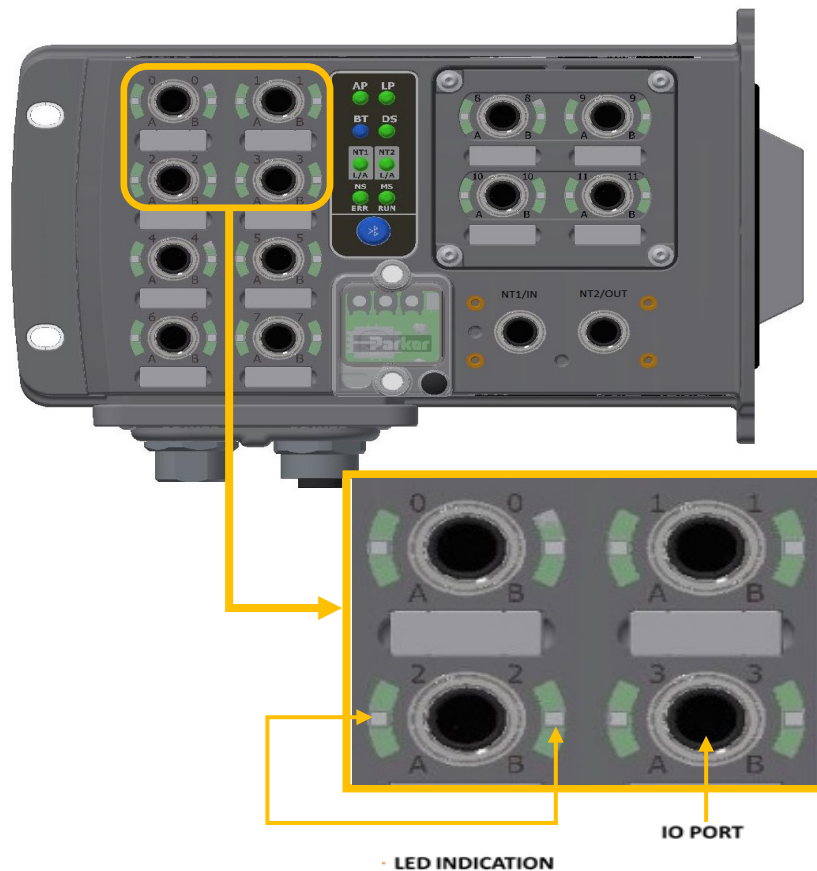

Figure 14 — IO-Port LED

Table 18 — IO Port LED Indication

Color Indication	Status
OFF	Input is configured and input is OFF
Light Blue	Output is configured and output is OFF (Type A module) OR I/O is not configurable (Type B module)
Yellow	Input is ON or Output is actuated
Yellow flashing	During firmware upgrade
Red	Over current at I/O or IO-Link point
Red flashing	Short-circuit at supply/Validation Error/Data Storage Error/
Green	IO-Link Configured, and IO-Link slave connected
Green rapid flashing	IO-Link port is getting configured
Green flashing	IO-Link Configured, and IO-Link slave not connected
Magenta	The application image present in flash is not valid
Magenta flashing	Watchdog error

CHAPTER - 3 Technical Data



Technical Data

3.1 Dimensions:

Footprint dimensions: length, width, height of entire PCH

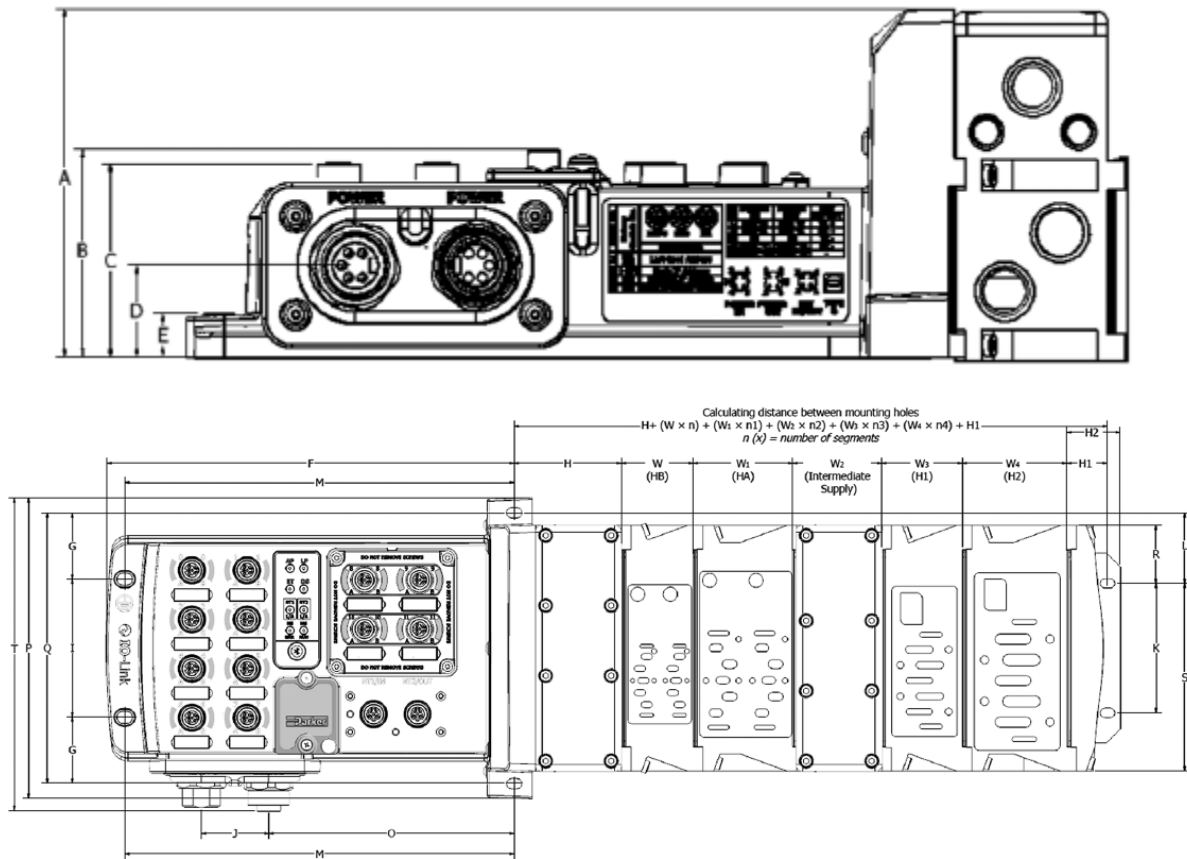

$n(x)$ = number of segments

A	B	C	D	E	F	G	H	H ₁	H ₂	J	K	L
4.42	2.64	2.46	1.17	.55	9.32	1.51	2.36	.9	1.22	1.55	2.95	1.6
(112.3)	(67.1)	(62.5)	(29.7)	(14)	(236.7)	(38.4)	(59.9)	(22.9)	(31)	(39.4)	(74.9)	(40.6)
M	O	P	Q	R	S	T	W	W ₁	W ₂	W ₃	W ₄	
8.91	5.61	6.86	6.18	1.33	4.28	7.14	1.63	2.28	2.03	1.82	2.39	
(226.3)	(142.5)	(174.2)	(157)	(33.8)	(108.7)	(181.4)	(41.4)	(57.9)	(51.6)	(46.2)	(60.7)	

Inches (mm)

Mounting holes dimensions

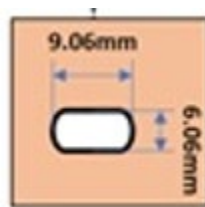

Figure 15 — Physical Dimensions

Technical Data

3.2 Mechanical Data

Table 19 — Mechanical Data

Parameters	Details
Housing material	Housing /Enclosure: PBT with 33% GF and UL94-V0 Base Cover (plate): Aluminum 380
Enclosure rating	IP 65 (only when plugged-in and threaded-in)
Supply Voltage	7/8" 4 or 5 pin male and female pin connector
Input ports/ Output ports	M12, A-coded (12 x female)
Dimensions (L x B x H in mm)	226.6mm x 130.7mm x 55mm
Mounting type	Screw Mount
Ground strap attachment	M5
Weight	Approx. 1.3 kg

3.3 Operating Conditions

Table 20 — Operating Conditions

Parameters	Details
Operating Temperature	0°C to 50°C
Storage Temperature	-25°C to 70°C
Industrial Immunity	IEC 61000-6-2
Industrial Emission	IEC 61000-6-4
Shock/Vibrations	IEC 60068-2-27:2008
	IEC 60068-2-6:2007
Electrostatic Discharge	IEC 61000-4-2
Electrical Fast Transient/ Burst	IEC 61000-4-4
Surge Immunity	IEC 61000-4-5

3.4 Electrical Data

Table 21 — Electrical Data

Topic	Details
Supply Voltage	24VDC (-15% to +20%)
Logic current at 24 V (V1)	Max Current 8A – Actual usage depends on configuration.
Auxiliary current at 24 V (V2)	Max Current 12A – Actual usage depends on configuration.
Input current at 24V (Zone 1-3)	Max Current 3.84A – Actual usage depends on configuration.
Input current at 24V (Zone 4)	Max Current 1.28A – Actual usage depends on configuration

CHAPTER - 4 PCH Portal Function

PCH Portal Function

4.1 Slots and Module Description

The PCH Portal for PROFINET is configured with the provided GSDML file. The PROFINET controller identifies PCH Portal with the GSDML file and defines the number of input and output process bytes and the module parameters for configuring the device.

Table 22 — Slot configuration

Slot No.	Module name	Properties
0	Bus Node "PCH Portal"	The bus node "PCH Portal" is always the first module in the configuration.
1	Device Status and Control Module	Status and Control module is fixed, default and non-configurable module. It has 12 status input bytes and 1 control output byte.
2	Standard Input Output Module	Standard Input Output Module is default and configurable. It has 3-bytes inputs and 3-bytes output module.
3	Valve module	Valve Module is default and configurable. It has 4 output bytes to control 32 valves.
4	Module IO-Link A or Module IO-Link B or Module IO-Link B+	IO-Link module has 4 to 8 submodules which are flexible and reconfigurable. These IO-Link submodules support varying size of the process data and can be used with respect to the byte size of IO-Link device connected.
5	Module IO-Link A or Module IO-Link B or Module IO-Link B+	IO-Link module has 4 to 8 submodules which are flexible and reconfigurable. These IO-Link submodules support varying size of the process data and can be used with respect to the byte size of IO-Link device connected.
6	Module IO-Link A or Module IO-Link B or Module IO-Link B+ for 12 Port PCH Portal Or Extended Bus for 8 Port PCH Portal	IO-Link module has 4 to 8 submodules which are flexible and reconfigurable. These IO-Link submodules support varying size of the process data and can be used with respect to the byte size of IO-Link device connected.
7	Extended Bus for 12 Port PCH Portal Or None for 8 Port PCH Portal	It is 28 input bytes and 100 output bytes. It can be used for module expansion.

PCH Portal Function

4.1.1 Device Status and Control Module

The Status Module is used to diagnose the PCH Portal. It will help in identifying the faults and warnings that will be reported by the device.

Note: for an explanation of the behaviour of the diagnostic bits contained in Bytes 0 and 1, please refer to Table 38: Process Input Status Bits.

Table 23 — Device Status and Control Module

Byte No.	Input Bits								Description
	7	6	5	4	3	2	1	0	
1	External Module	Safety	Valve	IO/IO-LINK	Network	Logic Voltage	Auxiliary Voltage	MS/CoProc	1- Error/Warning occurred 0 - No Error/Warning
2	Target Count	External Sensor Power Fault	Temperature Warning	Auxiliary Current	Logic Current	Trending Data	Warning	Error	1- Error/Warning occurred 0 - No Error/Warning
3	RESERVED			OC3	OC2	OC1	OC	FS	<u>FS - Fuse Status</u> 0 - Fuse Not Blown 1 - Fuse Blown. <u>Over Current Status</u> OC – Latched OC OCx – OC at module position x=1/2/3 0 – No OC 1 – OC detected
4	RESERVED								
5	VF07	VF06	VF05	VF04	VF03	VF02	VF01	VF00	<u>VF - Valve Fault Status</u> 0 - No Fault 1 - Short to Ground
6	VF15	VF14	VF13	VF12	VF11	VF10	VF09	VF08	
7	VF23	VF22	VF21	VF20	VF19	VF18	VF17	VF16	
8	VF31	VF30	VF29	VF28	VF27	VF26	VF25	VF24	
9	RESERVED								
10									
11									
12									
Byte No.	Output Bits								Description
	7	6	5	4	3	2	1	0	
1	RESERVED							RST	<u>RST – Reset Event</u> 1- Reset 0 - No action

NOTE: A shorted condition of Pin-1 to common/ground will open the (FS) fuse. An Over current condition of Pin-2 or Pin-4 to common/ground with the output ON will latch the OC bit and the OC1, 2, or 3 bits are set according to which module the Over current condition occurred.

Example: When Over Current occurs at Port 5B, OC2 and OC bits get set. When Over Current condition is removed OC2 bit gets reset, but OC bit remains set.

PCH Portal Function

4.1.2 Standard IO Module

This module consists of 3 bytes of Digital Inputs and 3 bytes of Digital Outputs. Since there can be maximum 24 channels of PCH Portal, all the 24 channels are sequentially mapped to the bits of this module.

Table 24 — Standard IO Module

Byte No.	Input Bits								Description
	7	6	5	4	3	2	1	0	
1	Ch. B3	Ch. A3	Ch. B2	Ch. A2	Ch. B1	Ch. A1	Ch. B0	Ch. A0	Input Channel Data(I) 0 - OFF 1 - ON if a port is configured as an IO-Link port or Output, bit must remain 0
2	Ch. B7	Ch. A7	Ch. B6	Ch. A6	Ch. B5	Ch. A5	Ch. B4	Ch. A4	
3	Ch. B11	Ch. A11	Ch. B10	Ch. A10	Ch. B9	Ch. A9	Ch. B8	Ch. A8	
Byte No.	Output Bits								Description
	7	6	5	4	3	2	1	0	
1	Ch. B3	Ch. A3	Ch. B2	Ch. A2	Ch. B1	Ch. A1	Ch. B0	Ch. A0	Output Channel Data(O) 0 - OFF 1 - ON if a channel is configured as an IO-Link port or Input, bit must remain 0
2	Ch. B7	Ch. A7	Ch. B6	Ch. A6	Ch. B5	Ch. A5	Ch. B4	Ch. A4	
3	Ch. B11	Ch. A11	Ch. B10	Ch. A10	Ch. B9	Ch. A9	Ch. B8	Ch. A8	

4.1.3 Valve Module

There is possibility of 32 valves that can be used along with PCH Portal. This module has 4 bytes, and all bits are sequentially mapped to the 32 valves that can be connected to the device.

Table 25 — Valve Module

Byte No.	Output Bits								Description
	7	6	5	4	3	2	1	0	
1	V07	V06	V05	V04	V03	V02	V01	V00	Valve Output Data Vxx -> Output on Valve xx xx range is 0 to 31
2	V15	V14	V13	V12	V11	V10	V9	V08	
3	V23	V22	V21	V20	V19	V18	V17	V16	
4	V31	V30	V29	V28	V27	V26	V25	V24	

PCH Portal Function

4.1.4 IO-Link Modules

IO-Link modules consist of 2 to 4 submodules and IO-Link status module based on the type of IO-Link module used.

Table 26 — IO-Link Modules

Module Name	Description
Module IO-Link A	The Module IO-Link A can have maximum 4 IO submodules and 4 status modules. Minimum byte size is 1 byte and maximum byte size of an IO-Link submodule can be 32. The Status module size is fixed to 6 bytes. User has flexibility to use minimum 1 and maximum 8 submodules.
Module IO-Link B	The Module IO-Link A can have maximum 4 IO submodules and 4 status modules. Minimum byte size is 1 byte and maximum byte size of an IO-Link submodule can be 32. The Status module size is fixed to 6 bytes. User has flexibility to use minimum 1 and maximum 8 submodules.
Module IO-Link B AUX	This module B AUX is a variant of Module IO-Link B except that it can host maximum 2 submodules and 2 IO-Link status modules. Minimum byte size is 1 byte and maximum byte size of an IO-Link submodule can be 32. The Status module size is fixed to 6 bytes. User has flexibility to use minimum 1 and maximum 4 submodules.

NOTE: There is limitation while using IO-Link Module with only 1 submodule at a sub-slot. Hence, minimum 2 submodules must be used and configured if only 1 IO-Link port is connected. The additional (dummy) submodule can be "IOL-1 Input byte" or "IOL-1 Output byte" from the available list of submodules to keep the byte consumption minimum.

PCH Portal Function

4.1.5 IO-Link IO Submodules

The IO-Link submodules can only be used at the sub slots of Module IO-Link. The submodules are flexible in terms of byte size and reconfigurable at any sub slots. Table 27 shows possible submodules that are available for use.

Table 27 — IO-Link IO submodules

Submodule Name	IO Type	Input/Output Bits
IOL-1 Input byte	Input	IO-Link Data - 1Byte
	Output	Not Applicable
IOL-2 Input byte	Input	IO-Link Data - 2Byte
	Output	Not Applicable
IOL-4 Input byte	Input	IO-Link Data - 4Byte
	Output	Not Applicable
IOL-6 Input byte	Input	IO-Link Data - 6Byte
	Output	Not Applicable
IOL-8 Input byte	Input	IO-Link Data - 8Byte
	Output	Not Applicable
IOL-10 Input byte	Input	IO-Link Data - 10Byte
	Output	Not Applicable
IOL-16 Input byte	Input	IO-Link Data - 16Byte
	Output	Not Applicable
IOL-24 Input byte	Input	IO-Link Data - 24Byte
	Output	Not Applicable
IOL-32 Input byte	Input	IO-Link Data - 32Byte
	Output	Not Applicable
IOL-1 Output byte	Input	Not Applicable
	Output	IO-Link Data - 1Byte
IOL-2 Output byte	Input	Not Applicable
	Output	IO-Link Data - 2Byte
IOL-4 Output byte	Input	Not Applicable
	Output	IO-Link Data - 4Byte
IOL-6 Output byte	Input	Not Applicable
	Output	IO-Link Data - 6Byte
IOL-8 Output byte	Input	Not Applicable
	Output	IO-Link Data - 8Byte
IOL-10 Output byte	Input	Not Applicable
	Output	IO-Link Data - 10Byte
IOL-16 Output byte	Input	Not Applicable
	Output	IO-Link Data - 16Byte
IOL-24 Output byte	Input	Not Applicable
	Output	IO-Link Data - 24Byte
IOL-32 Output byte	Input	Not Applicable
	Output	IO-Link Data - 32Byte
IOL-1 Input byte, IOL-1 Output byte	Input	IO-Link Data - 1Byte
	Output	IO-Link Data - 1Byte

PCH Portal Function

Submodule Name	IO Type	Input/Output Bits
IOL-2 Input byte, IOL-2 Output byte	Input	IO-Link Data - 2Byte
	Output	IO-Link Data - 2Byte
IOL-2 Input byte, IOL-4 Output byte	Input	IO-Link Data - 2Byte
	Output	IO-Link Data - 4Byte
IOL-4 Input byte, IOL-2 Output byte	Input	IO-Link Data - 4Byte
	Output	IO-Link Data - 2Byte
IOL-4 Input byte, IOL-4 Output byte	Input	IO-Link Data - 4Byte
	Output	IO-Link Data - 4Byte
IOL-2 Input byte, IOL-8 Output byte	Input	IO-Link Data - 2Byte
	Output	IO-Link Data - 8Byte
IOL-4 Input byte, IOL-8 Output byte	Input	IO-Link Data - 4Byte
	Output	IO-Link Data - 8Byte
IOL-8 Input byte, IOL-2 Output byte	Input	IO-Link Data - 8Byte
	Output	IO-Link Data - 2Byte
IOL-8 Input byte, IOL-4 Output byte	Input	IO-Link Data - 8Byte
	Output	IO-Link Data - 4Byte
IOL-8 Input byte, IOL-8 Output byte	Input	IO-Link Data - 8Byte
	Output	IO-Link Data - 8Byte
IOL-4 Input byte, IOL-32 Output byte	Input	IO-Link Data - 4Byte
	Output	IO-Link Data - 32Byte
IOL-32 Input byte, IOL-4 Output byte	Input	IO-Link Data - 32Byte
	Output	IO-Link Data - 4Byte
IOL-16 Input byte, IOL-16 Output byte	Input	IO-Link Data - 16Byte
	Output	IO-Link Data - 16Byte
IOL-24 Input byte, IOL-24 Output byte	Input	IO-Link Data - 24Byte
	Output	IO-Link Data - 24Byte
IOL-32 Input byte, IOL-32 Output byte	Input	IO-Link Data - 32Byte
	Output	IO-Link Data - 32Byte

PCH Portal Function

4.1.6 IO-Link Status Submodule

Table 28 — IO-Link Status submodules

	Input Bits								Description
	7	6	5	4	3	2	1	0	
Port x IO-Link Status Module (x = 0 to 11)	RESV	EV	SC	PDI	DF	VF	DC	IOL	<u>IOL - IO-Link Status</u> 0 - Port is not IO-Link 1 - IO-link Port enabled <u>DC - Device Connect Status</u> 0 - Not Connected/Disconnected 1 - Device Connected <u>VF - Validation Status</u> 0 - Validation ok 1 - Validation Fail <u>DF - Data Storage Validation</u> 0 - Validation OK 1 - Data Storage Validation Fail <u>PDI - Process Data status</u> 0 - Process Data Valid 1 - Process Data Invalid <u>SC - IOL Short Circuit Status</u> 0 - No IOL Short Circuit 1 - IOL Short Circuit occurred <u>EV - Event Status</u> 0 - No event present 1 - Event Present in IO-Link
	Vendor ID 1								Vendor ID
	Vendor ID 2								
	Device ID 1								Device ID
	Device ID 2								
	Device ID 3								

4.1.7 Extended Module

Table 29 — Extended Modules

Submodule Name	IO Type	Input/output Bits	Description
28 bytes Input / 100 bytes Output	Input	External Module Data	Reserved for external module data
	Output	External Module Data	

PCH Portal Function

4.2 Module Parameters

4.2.1 Port Configuration and Module Parametrization

The port configuration parameters can be found in Module Parameters of head module at slot 0. These parameters are used to configure the channels as shown in below table:

Table 30 — Port Configuration Parameters

Channel Name	Options	Values
Module Parametrization	0 - Disable. 1 - Enable	When module parameterization is enabled PCH will accept configuration from Engineering tool or PLC. Irrespective of module parameterization (Enable/Disable) PCH will accept configuration from Web interface or Configuration tool.
A0 Port Type	Option A	Option A configuration values: 1. Input PNP 2. Input NPN 3. Output Option B configuration values: 1. Input PNP 2. Input NPN 3. Output 4. IO-Link
B0 Port Type	Option B	
A1 Port Type	Option A	
B1 Port Type	Option B	
A2 Port Type	Option A	
B2 Port Type	Option B	
A3 Port Type	Option A	
B3 Port Type	Option B	
A4 Port Type	Option A	
B4 Port Type	Option B	
A5 Port Type	Option A	
B5 Port Type	Option B	
A6 Port Type	Option A	
B6 Port Type	Option B	
A7 Port Type	Option A	
B7 Port Type	Option B	
A8 Port Type	Option A	
B8 Port Type	Option B	
A9 Port Type	Option A	
B9 Port Type	Option B	
A10 Port Type	Option A	
B10 Port Type	Option B	
A11 Port Type	Option A	
B11 Port Type	Option B	

PCH Portal Function

4.2.2 Standard IO Module Parameters

The standard IO parameters which include Fault Mode, Counter Control, Counter Type, DI Inversion and De-bounce Time can be found under the properties of Standard Input Output Module.

Table 31 — Standard IO Module Parameters

Record Name	Channel Name	Values
Fault Mode	A0 Fault Mode	This parameter will have following options: 1. OFF 2. Last Good Fault Mode (FM): This field is presently not used and the same will be removed from the data map in next release
	B0 Fault Mode	
	A1 Fault Mode	
	B1 Fault Mode	
	A2 Fault Mode	
	B2 Fault Mode	
	A3 Fault Mode	
	B3 Fault Mode	
	A4 Fault Mode	
	B4 Fault Mode	
	A5 Fault Mode	
	B5 Fault Mode	
	A6 Fault Mode	
	B6 Fault Mode	
DIO Counter Control	A0 Counter Control	This parameter will have following options: 1. Disable 2. Enable This parameter enables or disables the cycle count limit notification functionality of digital input or output for the corresponding channel. It also enables/disables changing of counter type and cycle reset parameter. If this parameter is enabled, then the PCH device will raise cycle limit reached warning when the cycle count limit is reached. The cycle count limit is configured through configuration tool. This has following two values: Enable (1): Warning mode enabled. Disable (0): Warning mode disabled
	B0 Counter Control	
	A1 Counter Control	
	B1 Counter Control	
	A2 Counter Control	
	B2 Counter Control	
	A3 Counter Control	
	B3 Counter Control	
	A4 Counter Control	
	B4 Counter Control	
	A5 Counter Control	
	B5 Counter Control	
	A6 Counter Control	
	B6 Counter Control	
A7 Counter Control		

PCH Portal Function

Record Name	Channel Name	Values
DIO Counter Control	B7 Counter Control	
	A8 Counter Control	
	B8 Counter Control	
	A9 Counter Control	
	B9 Counter Control	
	A10 Counter Control	
	B10 Counter Control	
	A11 Counter Control	
	B11 Counter Control	
DIO Counter Type	A0 Counter Type	<p>This parameter will have following options:</p> <ol style="list-style-type: none"> Up Down <p>This parameter defines the behavior of cycle count parameter of the digital IO as an up counter or down counter for the corresponding channel. This parameter has following two values.</p> <p>Up counter (0): The cycle count associated with digital IO will increment by one for every cycle of digital IO. The cycle count will continue to increment beyond the configured cycle limit value (up to max limit of 20,000,000) in case cycle count type is configured as up counter. The cycle count will stop incrementing after it reaches the max limits of 20,000,000.</p> <p>Down counter (1): The cycle count associated with digital IO will decrement by one for every cycle of digital IO. The cycle count will not decrement beyond zero after the respective IO is operated more than the configured maximum cycles in case the cycle type is configured as down counter. The transition of digital IO from OFF to ON to OFF will be counted as one cycle.</p>
	B0 Counter Type	
	A1 Counter Type	
	B1 Counter Type	
	A2 Counter Type	
	B2 Counter Type	
	A3 Counter Type	
	B3 Counter Type	
	A4 Counter Type	
	B4 Counter Type	
	A5 Counter Type	
	B5 Counter Type	
	A6 Counter Type	
	B6 Counter Type	
	A7 Counter Type	
	B7 Counter Type	
	A8 Counter Type	
	B8 Counter Type	
	A9 Counter Type	
B9 Counter Type		
A10 Counter Type		
B10 Counter Type		
A11 Counter Type		
B11 Counter Type		
DI Inversion	A0 DI Inversion	
	B0 DI Inversion	
	A1 DI Inversion	
	B1 DI Inversion	
	A2 DI Inversion	
	B2 DI Inversion	
	A3 DI Inversion	
	B3 DI Inversion	
	A4 DI Inversion	
	B4 DI Inversion	
	A5 DI Inversion	

PCH Portal Function

Record Name	Channel Name	Values
DI Inversion	B5 DI Inversion	<p>This parameter will have following options:</p> <ol style="list-style-type: none"> 1. OFF 2. ON <p>This parameter enables or disables the inversion on digital input for each corresponding input channel. If this parameter is enabled, then inverted status of respective input is communicated to PLC and configuration utility. The invert functionality is not applicable to LED indication on the PCH Portal. This parameter has two values:</p> <p>ON (1): Enables the inversion mode in the PCH Portal.</p> <p>OFF (0): Disables the inversion mode in the PCH Portal.</p>
	A6 DI Inversion	
	B6 DI Inversion	
	A7 DI Inversion	
	B7 DI Inversion	
	A8 DI Inversion	
	B8 DI Inversion	
	A9 DI Inversion	
	B9 DI Inversion	
	A10 DI Inversion	
	B10 DI Inversion	
	A11 DI Inversion	
B11 DI Inversion		
De-bounce Time	A0 De-bounce Time	<p>This parameter defines the de-bounce time for each corresponding channel to avoid jitter in the input signal. This parameter applies for both ON to OFF and OFF to ON transition. If the de-bounce time configured is 0, then it disables the de-bounce logic.</p> <p>The valid range of this parameter 0 to 120 ms in decimal.</p>
	B0 De-bounce Time	
	A1 De-bounce Time	
	B1 De-bounce Time	
	A2 De-bounce Time	
	B2 De-bounce Time	
	A3 De-bounce Time	
	B3 De-bounce Time	
	A4 De-bounce Time	
	B4 De-bounce Time	
	A5 De-bounce Time	
	B5 De-bounce Time	
	A6 De-bounce Time	
	B6 De-bounce Time	
	A7 De-bounce Time	
	B7 De-bounce Time	
	A8 De-bounce Time	
	B8 De-bounce Time	
	A9 De-bounce Time	
	B9 De-bounce Time	
	A10 De-bounce Time	
	B10 De-bounce Time	
A11 De-bounce Time		
B11 De-bounce Time		

PCH Portal Function

4.2.3 Valve Module Parameters

The Valve parameters are available for user configuration when the Valve Module is used at slot 3. Following table shows all the valve parameters.

Table 32 — Valve Module Parameters

Record Name	Channel Name	Values
Fault Mode	Fault Mode 0	<p>This parameter has following options:</p> <ol style="list-style-type: none"> 1. OFF 2. Last Good <p>The Fault Value settings describes the behavior of the valve outputs in case a communication error is detected between PLC and the PCH Portal. This has following two values:</p> <p>Last Good (1): The selected valves will be set to last good value after the communication error is detected.</p> <p>Off (0): The selected valves will be set to OFF state after the communication error is detected.</p>
	Fault Mode 1	
	Fault Mode 2	
	Fault Mode 3	
	Fault Mode 4	
	Fault Mode 5	
	Fault Mode 6	
	Fault Mode 7	
	Fault Mode 8	
	Fault Mode 9	
	Fault Mode 10	
	Fault Mode 11	
	Fault Mode 12	
	Fault Mode 13	
	Fault Mode 14	
	Fault Mode 15	
	Fault Mode 16	
	Fault Mode 17	
	Fault Mode 18	
	Fault Mode 19	
	Fault Mode 20	
	Fault Mode 21	
	Fault Mode 22	
	Fault Mode 23	
	Fault Mode 24	
	Fault Mode 25	
	Fault Mode 26	
	Fault Mode 27	
	Fault Mode 28	
	Fault Mode 29	
	Fault Mode 30	
	Fault Mode 31	
Counter Control	Counter Control 0	
	Counter Control 1	
	Counter Control 2	
	Counter Control 3	
	Counter Control 4	
	Counter Control 5	
	Counter Control 6	

PCH Portal Function

Record Name	Channel Name	Values
Counter Control	Counter Control 7	<p>This parameter will have following options:</p> <ol style="list-style-type: none"> Disable Enable <p>This parameter enables or disables the cycle count limit notification functionality of valve output. If this parameter is enabled, then the PCH device will raise cycle limit reached warning when the cycle count limit is reached. The cycle count limit is configured through configuration tool. This has following two values:</p> <p>Enable (1): Warning mode enabled. Disable (0): Warning mode disabled.</p>
	Counter Control 8	
	Counter Control 9	
	Counter Control 10	
	Counter Control 11	
	Counter Control 12	
	Counter Control 13	
	Counter Control 14	
	Counter Control 15	
	Counter Control 16	
	Counter Control 17	
	Counter Control 18	
	Counter Control 19	
	Counter Control 20	
	Counter Control 21	
	Counter Control 22	
	Counter Control 23	
	Counter Control 24	
	Counter Control 25	
	Counter Control 26	
Counter Control 27		
Counter Control 28		
Counter Control 29		
Counter Control 30		
Counter Control 31		
Valve Counter Type	Counter Type 1	<p>This parameter will have following options:</p> <ol style="list-style-type: none"> Up, Down <p>This parameter defines the behavior of cycle count parameter of the valve output as an up counter or down counter. This parameter has following two values:</p> <p>Up counter (0): The cycle associated with valve will increment by one for every cycle of valve output. The cycle count will continue to increment beyond the configured cycle limit valve (up to max limit of 20,000,000) in case cycle count type is configured as up counter. The cycle count will stop incrementing after it reaches the max limits of 10,000,000.</p> <p>Down counter (1): The cycle count associated with valve will decrement by one for every cycle of valve output. The cycle count will not decrement beyond zero after the respective valve is operated for more than the configured maximum</p>
	Counter Type 2	
	Counter Type 3	
	Counter Type 4	
	Counter Type 5	
	Counter Type 6	
	Counter Type 7	
	Counter Type 8	
	Counter Type 9	
	Counter Type 10	
	Counter Type 11	
	Counter Type 12	
	Counter Type 13	
	Counter Type 14	
	Counter Type 15	
	Counter Type 16	
	Counter Type 17	

PCH Portal Function

Record Name	Channel Name	Values
Valve Counter Type	Counter Type 18	cycles in case the cycle count type is configured as down counter.
	Counter Type 19	
	Counter Type 20	The transition of valve output from OFF to ON to OFF will be counted as one cycle.
	Counter Type 21	
	Counter Type 22	
	Counter Type 23	
	Counter Type 24	
	Counter Type 25	
	Counter Type 26	
	Counter Type 28	
	Counter Type 29	
	Counter Type 30	
	Counter Type 31	

PCH Portal Function

4.2.4 IO-Link Module Parameters

The IO-Link related parameters can be found in the properties of the submodules of the IO-Link. The possible settings for IO-Link are Cycle time, Validation mode and Parameter Server.

Table 33 — IO-Link Port Configuration

Record Name	Description	Values
Parameter Server	This parameter defines the behaviour of "Parameter Server (Data Storage)" of the IO-Link.	This parameter has following five values: <ul style="list-style-type: none"> • Disable • Upload Enable • Download Enable • Upload + Download Enable • Clear
Validation mode	This parameter defines the behaviour of "Validation mode" of the IO-Link.	This parameter has following three values: <ul style="list-style-type: none"> • No Validation • Compatible • Identical
Vendor ID 0	Vendor ID and Device ID settings of IO-Link Parameters can be used as per the manual of IO-Link device connected at the port.	Vendor ID (MSB)
Vendor ID 1		Vendor ID (LSB)
Device ID 0		Device ID (MSB)
Device ID 1		Device ID (Middle Byte)
Device ID 2		Device ID (LSB)
Cycle Time	This parameter can be used to influence the IO-Link communication speed.	This parameter can be set to automatic or is selectable from 0.8 to 132.8 ms. <ul style="list-style-type: none"> • Automatic • Range: 0.8 ms to 132.8 ms
Serial Number	Serial number setting of IO-Link Parameters can be used as per the manual of IO-Link device connected at the port.	16 bytes serial number of IO-Link device.

PCH Portal Function

4.3 Record Data Access

The PCH Portal errors, warnings and IO-Link records are accessible by the index mentioned in the below table:

Table 34 — Record Index Table

Index No.	Bits								Description
	B7	B6	B5	B4	B3	B2	B1	B0	
200	RESERVED				Auxiliary Voltage Warning Level		Auxiliary Voltage Fault Level		<u>Auxiliary Voltage Status (RO)</u> 0x00 - No Fault and Warning 0x01 - Low 0x10 - High 0x11 - No Supply or Low/High Voltage Cut-off.
201	Auxiliary Voltage Value Byte 1								<u>Auxiliary Voltage in mV (RO)</u>
	Auxiliary Voltage Value Byte 2								
202	RESERVED				Logic Voltage Warning Level		Logic Voltage Fault Level		<u>Logic Voltage Status (RO)</u> 0x00 - No Fault and Warning 0x01 - Low 0x10 - High 0x11 - Reserved
203	Logic Voltage Byte 1								<u>Logic Voltage in mV (RO)</u>
	Logic Voltage Byte 2								
204	RESERVED						Database Initialization Failed	Backplane Initialization Failed	<u>Device Start-up Fail (RO)</u> <u>Backplane Initialisation Fail (RO)</u> 0 - No Failure 1 - Failure
205	RESERVED						Backplane Break <Warning>	Backplane Break <Fault>	<u>Backplane Break (RO)</u> 0 - No Break 1 - Break
206	RESERVED				Watch Dog Expired Warning/Fault		Watch Dog Module		<u>Watch Dog Module (RO)</u> 0x00 - No Error 0x01 - Co-Proc 0x10 - Valve 0x11 - IO Module <u>Watch Dog Expired (RO)</u> 0x00 - No Warning/Fault 0x01 - Warning 0x10 - Fault 0x11 - Reserved

PCH Portal Function

Index No.	Bits								Description
	B7	B6	B5	B4	B3	B2	B1	B0	
207	Module Position - Watch Dog Expired								<u>Watch Dog Expired (RO)</u> 0 - No Watch Dog Expired 1-3 – Module Position. 4-255 – Reserved
208	VCL 07	VCL 06	VCL 05	VCL 04	VCL 03	VCL 02	VCL 01	VCL 00	<u>Valve Cycle Count Limit Status</u> 0 – Limit not Reached 1 – Limit Reached Note: Valve cycle count limit bit is set for 2 secs.
	VCL 15	VCL 14	VCL 13	VCL 12	VCL 11	VCL 10	VCL 09	VCL 08	
	VCL 23	VCL 22	VCL 21	VCL 20	VCL 19	VCL 18	VCL 17	VCL 16	
	VCL 31	VCL 30	VCL 29	VCL 28	VCL 27	VCL 26	VCL 25	VCL 24	
209	VCLR 07	VCLR 06	VCLR 05	VCLR 04	VCLR 03	VCLR 02	VCLR 01	VCLR 00	<u>Valve Cycle Count Reset (WO)</u> 0 - No Change 1 - Reset the Cycle Count
	VCLR 15	VCLR 14	VCLR 13	VCLR 12	VCLR 11	VCLR 10	VCLR 09	VCLR 08	
	VCLR 23	VCLR 22	VCLR 21	VCLR 20	VCLR 19	VCLR 18	VCLR 17	VCLR 16	
	VCLR 31	VCLR 30	VCLR 29	VCLR 28	VCLR 27	VCLR 26	VCLR 25	VCLR 24	
210	RESERVED				Valve Driver - 4	Valve Driver - 3	Valve Driver - 2	Valve Driver - 1	<u>Valve - SPI Comm/ Aux Power Supply Status (RO)</u> 0 - OK 1 - Warning
211	RESERVED				Valve Driver - 4	Valve Driver - 3	Valve Driver - 2	Valve Driver - 1	<u>Valve - SPI Comm/ Aux Power Supply Status (RO)</u> 0 - OK 1 - Fault
212	RESERVED						EEPROM Corrupt	EEPROM - I2C Communication Error	<u>EEPROM - I2C Comm Status (RO)</u> 0 - Comm OK 1 - Comm Fault <u>EEPROM – Corrupt Status (RO)</u> 0 - Not Corrupted 1 - Corrupted
213	ICL B3	ICL A3	ICL B2	ICL A2	ICL B1	ICL A1	ICL B0	ICL A0	<u>DI Cycle Count Limit Status (RO)</u> 0 – Limit not Reached 1 - Limit Reached. Note: Cycle Count Limit reached bit must be set for 2 secs.
	ICL B7	ICL A7	ICL B6	ICL A6	ICL B5	ICL A5	ICL B4	ICL A4	
	ICL B11	ICL A11	ICL B10	ICL A10	ICL B9	ICL A9	ICL B8	ICL A8	

PCH Portal Function

Index No.	Bits								Description
	B7	B6	B5	B4	B3	B2	B1	B0	
214	ICLR B3	ICLR A3	ICLR B2	ICLR A2	ICLR B1	ICLR A1	ICLR B0	ICLR A0	<u>DI Cycle Count Reset (WO)</u>
	ICLR B7	ICLR A7	ICLR B6	ICLR A6	ICLR B5	ICLR A5	ICLR B4	ICLR A4	0 - No Change
	ICLR B11	ICLR A11	ICLR B10	ICLR A10	ICLR B9	ICLR A9	ICLR B8	ICLR A8	1 - Reset the Cycle Count
215	OCL B3	OCL A3	OCL B2	OCL A2	OCL B1	OCL A1	OCL B0	OCL A0	<u>DO Cycle Count Limit Status (RO)</u>
	OCL B7	OCL A7	OCL B6	OCL A6	OCL B5	OCL A5	OCL B4	OCL A4	0 - Limit not Reached
	OCL B11	OCL A11	OCL B10	OCL A10	OCL B9	OCL A9	OCL B8	OCL A8	1 - Limit Reached Note: Cycle Count Limit bit must be set for 2 sec.
216	OCLR B3	OCLR A3	OCLR B2	OCLR A2	OCLR B1	OCLR A1	OCLR B0	OCLR A0	<u>DO Cycle Count Reset (WO)</u>
	OCLR B7	OCLR A7	OCLR B6	OCLR A6	OCLR B5	OCLR A5	OCLR B4	OCLR A4	0 - No Change
	OCLR B11	OCLR A11	OCLR B10	OCLR A10	OCLR B9	OCLR A9	OCLR B8	OCLR A8	1 - Reset the Cycle Count
217	ADC - I2C Communication Warning - Module Position								<u>ADC - I2C Comm Status (RO)</u> 0 - Comm OK 1-3 - Warning at Module Position 4-255 - Reserved
218	IO-Link Transceiver - USART 1 Communication Warning - Module Position								<u>IOL USART - 1 Comm Status (RO)</u> 0 - Comm OK 1-3 - Warning at Module Position 4-255 - Reserved
219	IO-Link Transceiver - USART 2 Communication Warning - Module Position								<u>IOL USART - 2 Comm Status (RO)</u> 0 - Comm OK 1-3 - Warning at Module Position 4-255 - Reserved
220	IO-Link Transceiver - USART 3 Communication Warning - Module Position								<u>IOL USART - 3 Comm Status (RO)</u> 0 - Comm OK 1-3 - Warning at Module Position 4-255 - Reserved
221	IO-Link Transceiver - USART 4 Communication Warning - Module Position								<u>IOL USART - 4 Comm Status (RO)</u> 0 - Comm OK 1-3 - Warning at Module Position 4-255 - Reserved

PCH Portal Function

Index No.	Bits								Description
	B7	B6	B5	B4	B3	B2	B1	B0	
222	External Flash Corrupt - Module Position								<u>EEPROM - SPI Comm Status (RO)</u> 0 - Comm OK 1-3 – Module Position 4-255 – Reserved
223	ADC - I2C Communication Error - Module Position								<u>ADC - I2C Comm Status (RO)</u> 0 - Comm OK 1-3 – Error at Module Position 4-255 – Reserved
224	IO-Link Transceiver - SPI Communication Error - Module Position								<u>IOL - SPI Comm Status (RO)</u> 0 - Comm OK 1-3 – Fault at Module Position 4-255 – Reserved
225	IO-Link Transceiver - USART 1 Communication Error - Module Position								<u>IOL USART - 1 Comm Status (RO)</u> 0 - Comm OK 1-3 – Fault at Module Position 4-255 – Reserved
226	IO-Link Transceiver - USART 2 Communication Error - Module Position								<u>IOL USART - 2 Comm Status (RO)</u> 0 - Comm OK 1-3 – Fault at Module Position 4-255 – Reserved
227	IO-Link Transceiver - USART 3 Communication Error - Module Position								<u>IOL USART - 3 Comm Status (RO)</u> 0 - Comm OK 1-3 – Fault at Module Position 4-255 – Reserved
228	IO-Link Transceiver - USART 4 Communication Error - Module Position								<u>IOL USART - 3 Comm Status (RO)</u> 0 - Comm OK 1-3 – Fault at Module Position 4-255 – Reserved

PCH Portal Function

Index No.	Bits								Description
	B7	B6	B5	B4	B3	B2	B1	B0	
229	External Module - Error - Module Position Note: - This is meant for non-classified error in external module								External Module – Fault status (RO) 0 - No Error 1-3 – Module Position 4-255 – Reserved
230	Fuse Status - Fault - Module Position								Fuse Status – Fault (RO) 0 - No Fuse Fault 1-3 – Module Position 4-255 – Reserved
231	Over Current - Fault - Module Position								Over Current (OC) – Fault (RO) 0 - No Fault 1-3 – OC at Module Position 4-255 – Reserved
232	Over Current - Fault - Channel No								Over Current – Fault (RO) 0 – No Fault at any channel 0 – 23: Channel No (Refer to Table 17 for Channel Description)
233	RESERVED						PLC Output Status	IP Address Status	PLC Output, IP Address Status (RO) 0(Active/Valid), 1(Disabled/Invalid)
234	Total 214 bytes (2 bytes of Total Events, 2 bytes of Event size, 210 bytes of event data)								Port 0 IO-Link Events (RO) (Refer to Table 35 for Description)
235	Total 214 bytes (2 bytes of Total Events, 2 bytes of Event size, 210 bytes of event data)								Port 1 IO-Link Events (RO)
236	Total 214 bytes (2 bytes of Total Events, 2 bytes of Event size, 210 bytes of event data)								Port 2 IO-Link Events (RO)
237	Total 214 bytes (2 bytes of Total Events, 2 bytes of Event size, 210 bytes of event data)								Port 3 IO-Link Events (RO)
238	Total 214 bytes (2 bytes of Total Events, 2 bytes of Event size, 210 bytes of event data)								Port 4 IO-Link Events (RO)
239	Total 214 bytes (2 bytes of Total Events, 2 bytes of Event size, 210 bytes of event data)								Port 5 IO-Link Events (RO)
240	Total 214 bytes (2 bytes of Total Events, 2 bytes of Event size, 210 bytes of event data)								Port 6 IO-Link Events (RO)

PCH Portal Function

Index No.	Bits								Description
	B7	B6	B5	B4	B3	B2	B1	B0	
241	Total 214 bytes (2 bytes of Total Events, 2 bytes of Event size, 210 bytes of event data)								Port 7 IO-Link Events (RO)
242	Total 214 bytes (2 bytes of Total Events, 2 bytes of Event size, 210 bytes of event data)								Port 8 IO-Link Events (RO)
243	Total 214 bytes (2 bytes of Total Events, 2 bytes of Event size, 210 bytes of event data)								Port 9 IO-Link Events (RO)
244	Total 214 bytes (2 bytes of Total Events, 2 bytes of Event size, 210 bytes of event data)								Port 10 IO-Link Events (RO)
245	Total 214 bytes (2 bytes of Total Events, 2 bytes of Event size, 210 bytes of event data)								Port 11 IO-Link Events (RO)

4.4 IO-Link Events

IO-Link Slave events can be read acyclic for each port.

If there is an IO-Link slave event, event bit gets set for the respective IO-Link Status module (refer IO-Link Status submodule section) and events can be read via an acyclic query on PLC.

Table 35 — IO-Link Events

Module	Parameter	Bytes
Event Read Response	Number of IO-Link Events (2 Bytes)	Byte 0 (MSB) & Byte 1
	Size of each IO-Link Event in bytes (2 Bytes)	Byte 2 (MSB) & Byte 3
	IO-Link Event 1 (7 Bytes)	Byte 4 (MSB) to 10 (Refer Table 36 for 7 bytes description)
	...	
	...	
	...	
	IO-Link Event 30 (7 Bytes)	Byte 208 (MSB) to 214 (Refer Table 36 for 7 bytes description)

Format of an IO-Link Event is as given in the following table.

Table 36 — Structure of an IO-Link Event Data

Module	Bit 7	Bit 6	Bit 5	Bit 4	Bit 3	Bit 2	Bit 1	Bit 0
Timestamp	Event Timestamp Byte 1 (Higher Byte)							
	Event Timestamp Byte 2							
	Event Timestamp Byte 3							
	Event Timestamp Byte 4 (Lower Byte)							
Event Qualifier	Mode		Type		Source	Instance		
Event Code	Event Code (Higher Byte)							
	Event Code (Lower Byte)							

PCH Portal Function

4.5 IO-Link Device parametrization

The standard Siemens IO_LINK_DEVICE function block can be used to access the IO-Link Index Sub-index data. Below table provides information for different parameters used in the IO_LINK_DEVICE function block. The CAP value used is 255 for PCH Portal devices.

Table 37 — IO-Link Acyclic Index Sub-Index Configuration

Parameter Name	Description	Value	Size in bytes
PN Index/CAP	PROFINET Index	Valid Index 255	1
Port/Instance No	IO-Link Port Number	Valid Port no (0 to 11) Reserved (12 to 255)	1
Control	Read or Write control	Read (03) Write (02)	1
IOL_Index	IO-Link Index value	0...32767	2
IOL_Subindex	IO-Link Sub-index value	0...255	1
IOL_Data	IO-Link Data Field Contains read response when Control used is read. Contains write request value when Control used is write	Method Specific	232

4.6 Protocol Dependent Functions

The device Supported the following PROFINET protocol specific functions.

- Topology discovery
- Address assignment via LLDP
- MRP (Media Redundancy Protocol)
- IRT (Isochronous Real-Time)
- FSU – Fast Start-Up (Prioritize startup)

To use Fast Start-Up, User needs to enable the Prioritized Start-up in the Configuration tool and set the port properties from automatic to fixed transmission rate.

4.7 TIA Portal

The PCH Portal can be used along with masters provided by different PROFINET master manufacturers which provides their own configuration tool. The commonly used tool to configure PROFINET masters is TIA Portal. The screenshots in the following sections are taken for TIA Portal to show how typically the PCH Portal is used with Siemens masters using TIA Portal.

PCH Portal Function

4.7.1 Integration

PCH Portal can be found in the Hardware Catalog pane as shown in below screenshot:

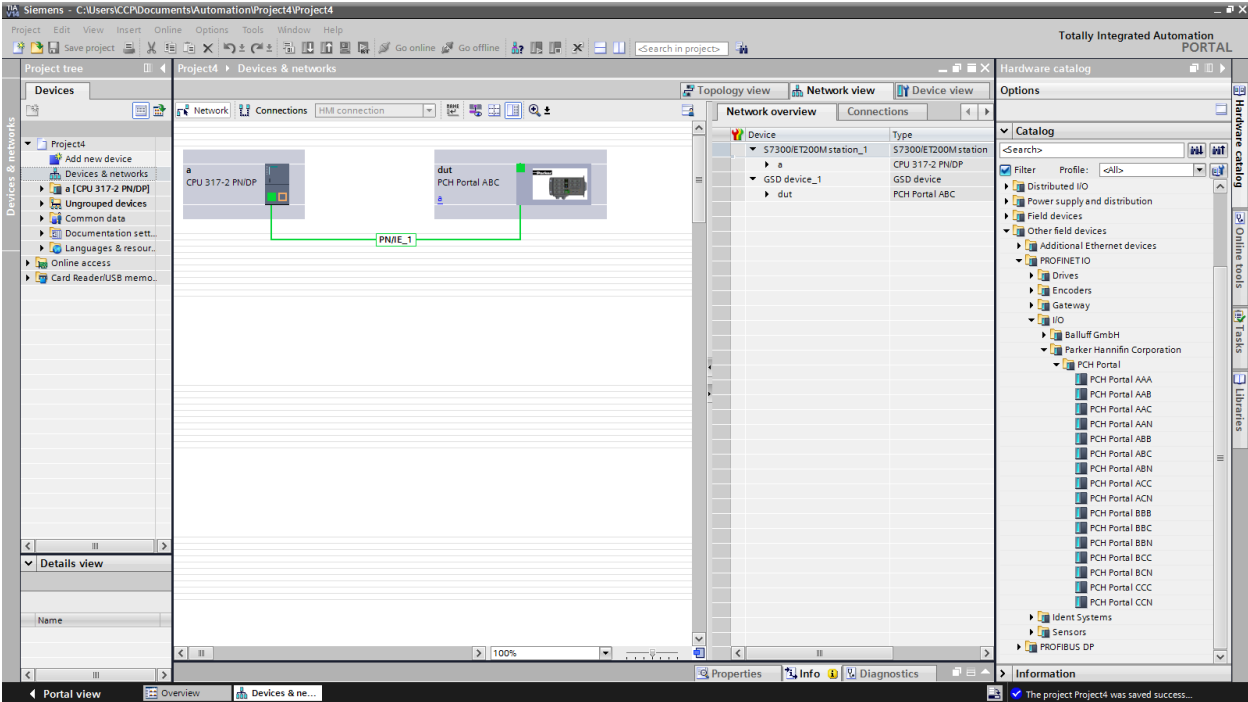

Figure 16 — PCH Portal

PCH Portal Function

4.7.2 Module Configuration

The typical module structure of PCH Portal for each slot and sub-slot is shown in the below figure:

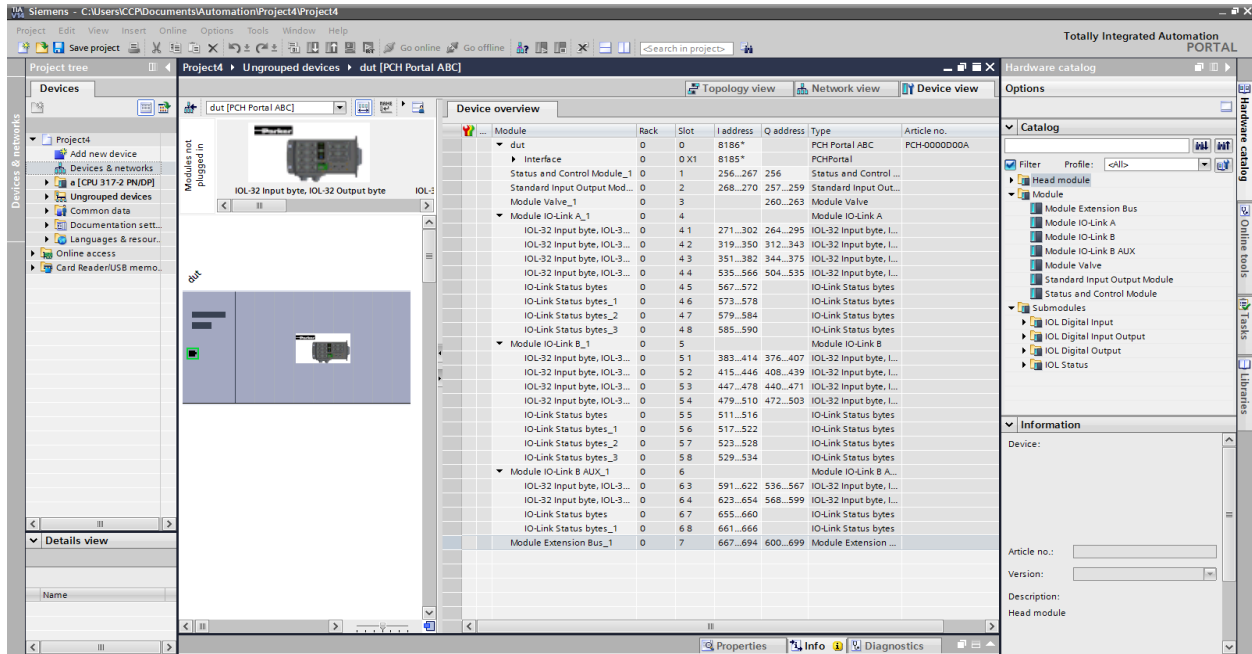

Figure 17 — Module Configuration

4.7.3 Module Parameters

The modules in the slot can be parametrized if they are used at the assigned slot location. Below subsections provides parameters associated with the modules used.

4.7.3.1 Basic Configuration Parameters

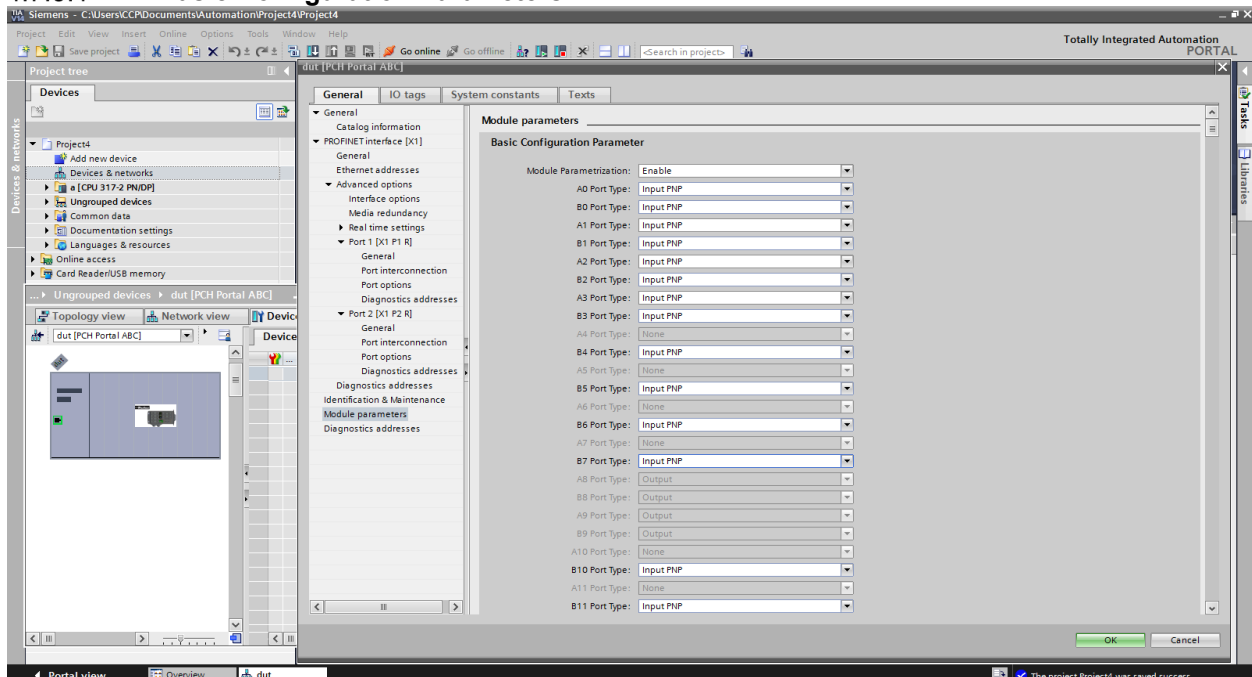

Figure 18 — Module Parameter

4.7.3.2 Standard Input Output Parameters

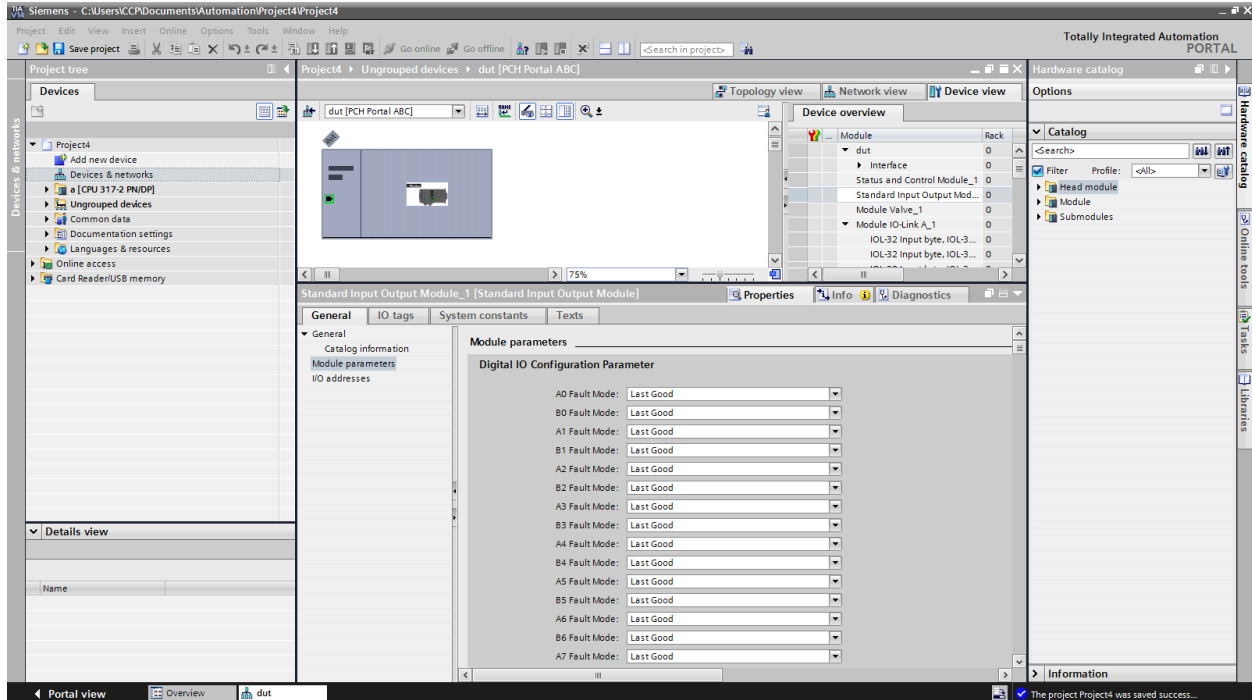

Figure 19 — Standard IO Parameter

4.7.3.3 Valve Parameters

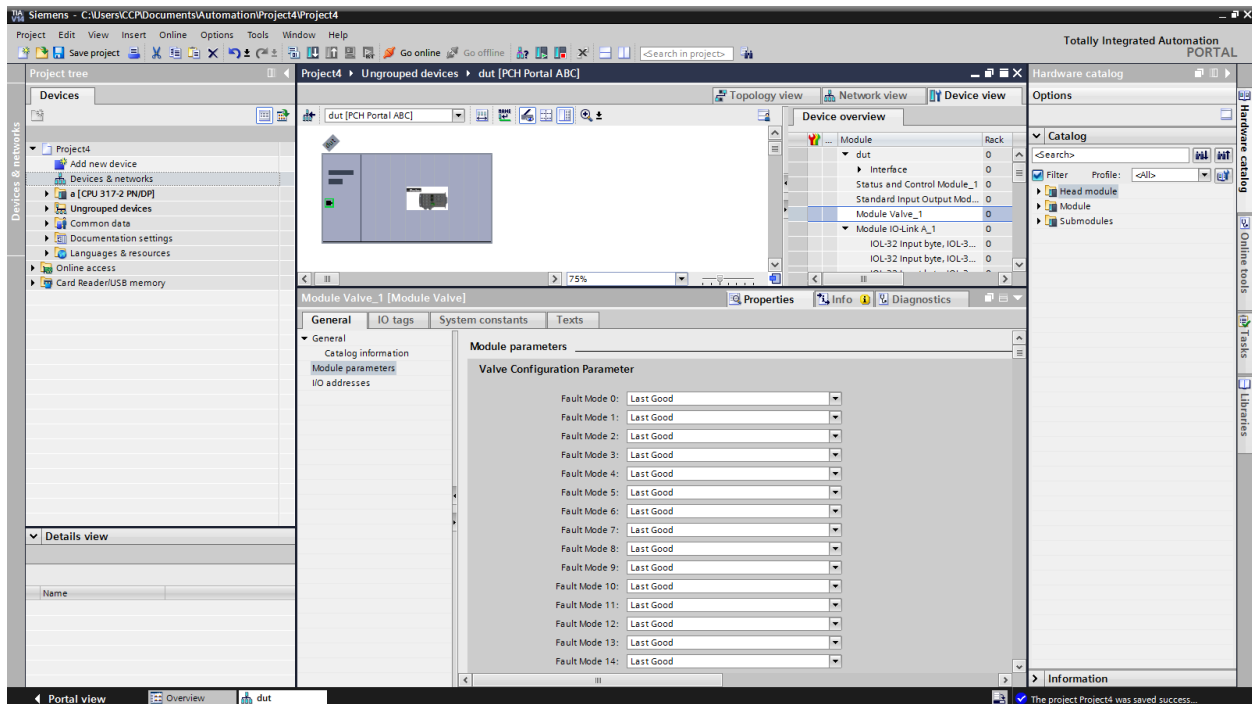

Figure 20 — Valve Parameter

4.7.3.4 IO-Link Parameters

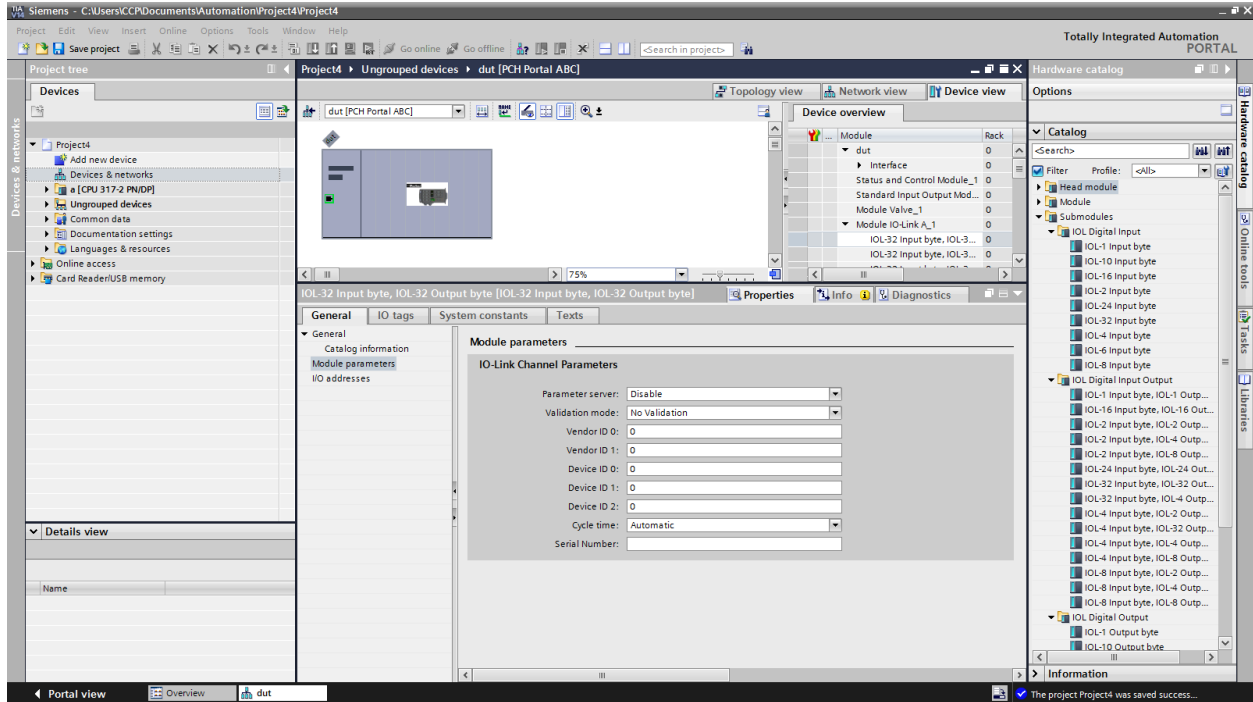

Figure 21 — IO-Link Parameters

CHAPTER - 5 **Configuration Tool/Web Interface**

Configuration Tool/Web Interface

The PCH Portal provides the following interfaces for configuration and monitoring of PCH Portal.

5.1 The PC Configuration Tool/Web Interface

The PC Configuration tool is Windows PC based windows application that communicates over USB and Bluetooth Interface to the PCH Portal.

To connect the PC configuration tool via USB interface connect the cable between the PC and PCH Portal and launch PCH Portal Configuration Tool to get connected with the PCH Portal.

To connect PCH Portal web page via Ethernet interface connect the ethernet cable between the PC and PCH Portal and enter the PCH portal's IP address in the browser.

User can select preferred language from the language dropdown. Supported languages are English, French, German, Italian, Chinese, Korean and Japanese.

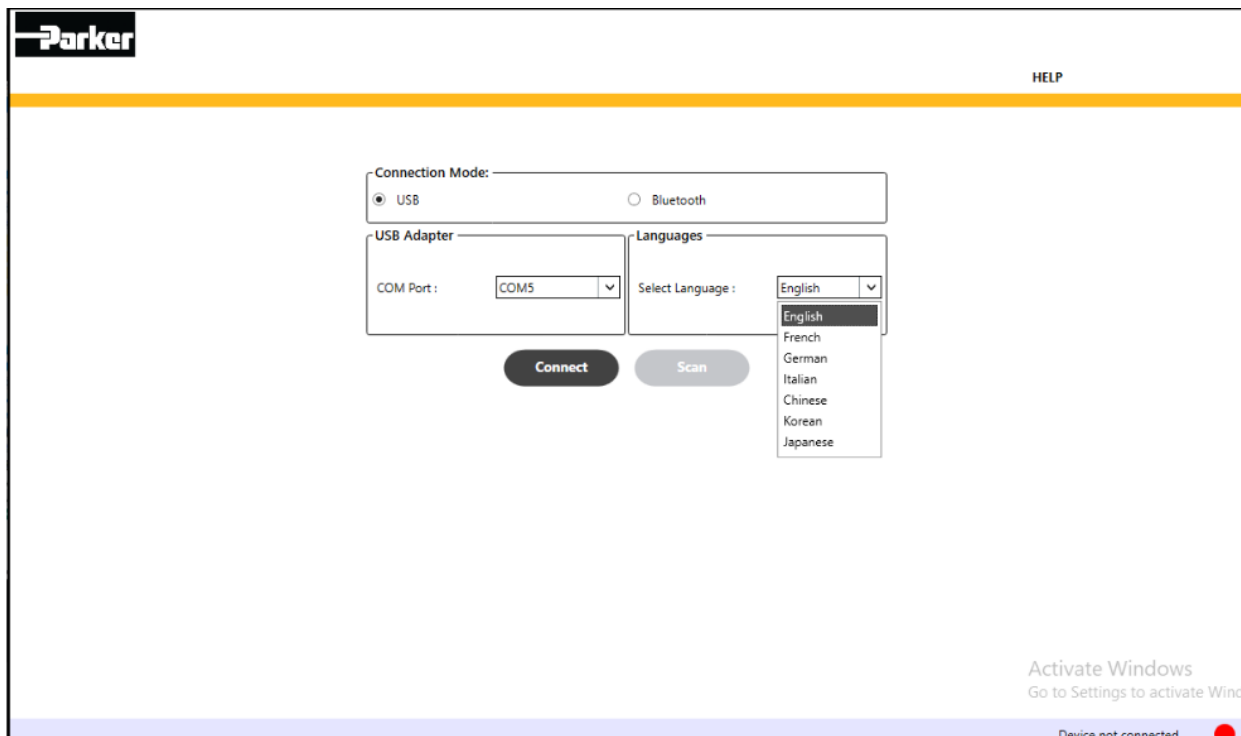

Figure 22 — PC Configuration Tool

Configuration Tool/Web Interface

To connect PC configuration tool via Bluetooth interface, a low energy USB Dongle (BLED112) must be connected to USB port of PC. Also, turn ON the Bluetooth on the PCH Portal by pressing the Bluetooth button for at least 3 seconds.

Select the 'Bluetooth' radio button on the screen. This will enable the 'Scan' button on the UI. To connect the PCH Portal, click on the 'Scan' button. After scan is completed the available PCH Portal devices will be shown. The PCH Portal device can be identified using the device name displayed in the scan device list. The PCH Portal device name will be displayed as PCH-XXXX where XXXX is the last 4 digits of the MAC address printed on the label of the PCH Portal.

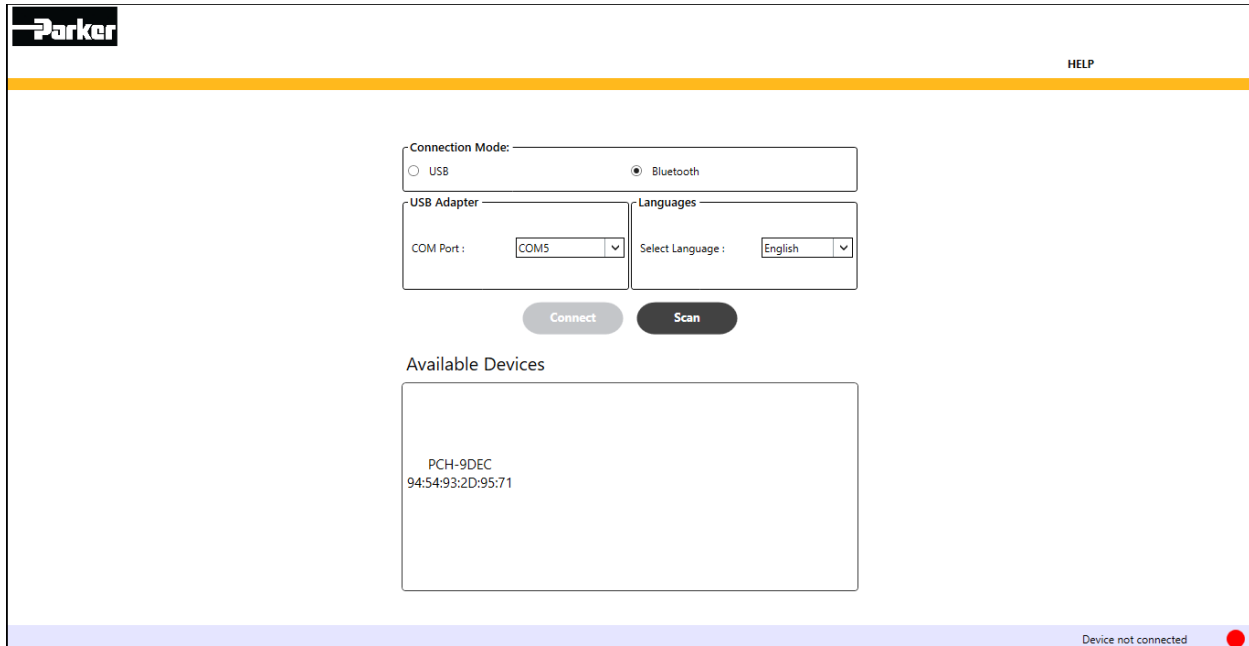

Figure 23 — Bluetooth Connection Screen

Configuration Tool/Web Interface

The screenshot displays the Parker PCH Portal web interface in a browser window. The interface is divided into several sections:

- Header:** Includes the Parker logo, navigation tabs (STATUS, CONFIGURATION, FORCE MODE, LOG, HELP), and mode selection (PLC Mode, Configure Mode). A language dropdown menu is open, showing options like English, Italian, French, German, Chinese, Korean, and Japanese.
- Status Section:** Features a photograph of the PCH10NABC0-P4 device and a table of valve tags.
- Device Information Section:** A table listing various device parameters such as Device Name, Protocol, IP Address, Bluetooth, and DHCP.
- LED Status Tables:** Two tables at the bottom show the status of various LEDs, including Aux Power, Logic Power, Bluetooth, Device Status, Port 1 LINK/Activity Status, Port 2 LINK/Activity Status, NS-ERR LED, and MS/RUN LED.
- Legend:** A color-coded legend at the bottom explains the status indicators for different LEDs.

Address	Valve Tag	Connect	state	Address	Valve Tag	Connect	state
0	EV0	OFF	●				
1	EV1	OFF	●				
2	EV2	OFF	●				
3	EV3	OFF	●				
4	EV4	OFF	●				
5	EV5	OFF	●				
6	EV6	OFF	●				
7	EV7	OFF	●				
8	EV8	OFF	●				
9	EV9	OFF	●				
10	EV10	OFF	●				
11	EV11	OFF	●				
12	EV12	OFF	●				
13	EV13	OFF	●				
14	EV14	OFF	●				
15	EV15	OFF	●				
16	EV16	OFF	●				
17	EV17	OFF	●				
18	EV18	OFF	●				
19	EV19	OFF	●				
20	EV20	OFF	●				
21	EV21	OFF	●				
22	EV22	OFF	●				
23	EV23	OFF	●				
24	EV24	OFF	●				
25	EV25	OFF	●				
26	EV26	OFF	●				
27	EV27	OFF	●				
28	EV28	OFF	●				
29	EV29	OFF	●				
30	EV30	OFF	●				
31	EV31	OFF	●				

LED	Status	Value	Description
Aux Power	●	24.45 V	Connected and within Limit
Logic Power	●	24.52 V	Connected and within Limit
Bluetooth	●	---	OFF
Device Status	●	---	Normal

LED	Status	Description
Port 1 LINK/Activity Status	●	Activity (100 Mbps)
Port 2 LINK/Activity Status	●	No link, no activity
NS-ERR LED	●	---
MS/RUN LED	●	---

Legend:

- Output Configured
- Input ON
- IO-Link Configured, but no device connected
- IO-Link Configured, device connected
- Output Forced ON
- Output Forced OFF
- IO pin is short-circuited or faulted
- Output ON

Figure 24 — Web Interface

NOTE:

- PCH Portal web page supports Microsoft Edge, Google Chrome and Mozilla Firefox browsers only.
- The GUI on web page is same as that on PC configuration tool.
- Please use latest version of browsers.

To configure PCH Portal enter Configuration mode by clicking on the “Configure mode” radio button and providing a valid password. The default password is “parker”. Configuration (write) access to PCH Portal is granted if it is not already in configuration mode.

While the PCH Portal is in Configuration mode, if the user connects the PLC, then the PLC does not gain control of the PCH until user releases the access from Configuration tool.

NOTE:

- Screens automatically refresh so inactivity is not applicable until web browser is closed and utility is closed.
- Once configuration mode is accessed by the PC Utility/Web server, the PLC cannot configure and actuate PCH Portal Outputs/Valves. PLC can read only inputs and device status from PCH Portal.

Configuration Tool/Web Interface

The “PLC Mode” radio button is selected if PLC is connected to the PCH Portal (refer to the upper right corner of the image below).

Parker PLC Mode Configure Mode

STATUS CONFIGURATION FORCE MODE LOG HELP

Status

PCH10NABC0-P4

Left click on Valve to navigate to Valve Configuration

Address	Valve Tag	Connect	State	Address	Valve Tag	Connect	State
0	EV0	OFF	ON				
1	EV1	OFF	ON				
2	EV2	OFF	ON				
3	EV3	OFF	ON				
4	EV4	OFF	ON				
5	EV5	OFF	ON				
6	EV6	OFF	ON				
7	EV7	OFF	ON				
8	EV8	OFF	ON				
9	EV9	OFF	ON				
10	EV10	OFF	ON				
11	EV11	OFF	ON				
12	EV12	OFF	ON				
13	EV13	OFF	ON				
14	EV14	OFF	ON				
15	EV15	OFF	ON				
16	EV16	OFF	ON				
17	EV17	OFF	ON				
18	EV18	OFF	ON				
19	EV19	OFF	ON				
20	EV20	OFF	ON				
21	EV21	OFF	ON				
22	EV22	OFF	ON				
23	EV23	OFF	ON				
24	EV24	OFF	ON				
25	EV25	OFF	ON				
26	EV26	OFF	ON				
27	EV27	OFF	ON				
28	EV28	OFF	ON				
29	EV29	OFF	ON				
30	EV30	OFF	ON				
31	EV31	OFF	ON				

Device Information

Device Name	pchportal		
Protocol	Profinet		
IP Address	192.168.1.8		
Bluetooth	OFF		
DHCP	Disabled		
Total Current Available	Logic	0.17 A	Aux <12 A
Maximum Current	Logic	8 A	Aux 12 A
Configuration Data Bytes	390		
Bytes Produced	500		
Bytes Consumed	492		
Serial Number	ABCD		

LED	Status	Value	Description
Aux Power	ON	24.45 V	Connected and within Limit
Logic Power	ON	24.56 V	Connected and within Limit
Bluetooth	OFF	-	OFF
Device Status	ON	-	Normal

LED	Status	Description
Port 1 LINK/Activity Status	ON	Activity (100 Mbps)
Port 2 LINK/Activity Status	OFF	No link, no activity
NS/ERR LED	ON	---
MS/RUN LED	ON	---

● Output Configured
 ● Input ON
 ● IO-Link Configured, but no device connected
 ● IO-Link Configured, device connected
● Output Forced ON
 ● Output Forced OFF
 ● IO pin is short - circuited or faulted
 ● Output ON

Device connected ●

Figure 25 — PLC Mode

Configuration Tool/Web Interface

5.1.1 Status Screen

The “Status” screen displays live status of the PCH Portal. All the device information like protocol, IP address etc. is displayed in the table on the right-hand side. Status of all the LEDs are displayed in the table at the bottom. Digital Input, Digital Output and IO-Link pin status is displayed on the device image on the left-hand side. Valve status is displayed in the table at the center

STATUS CONFIGURATION FORCE MODE LOG HELP

Status

PCH10NABC0-P4

Address	Valve Tag	Connect	State	Address	Valve Tag	Connect	State
0	EV0	OFF	ON	16	EV16	OFF	ON
1	EV1	OFF	ON	17	EV17	OFF	ON
2	EV2	OFF	ON	18	EV18	OFF	ON
3	EV3	OFF	ON	19	EV19	OFF	ON
4	EV4	OFF	ON	20	EV20	OFF	ON
5	EV5	OFF	ON	21	EV21	OFF	ON
6	EV6	OFF	ON	22	EV22	OFF	ON
7	EV7	OFF	ON	23	EV23	OFF	ON
8	EV8	OFF	ON	24	EV24	OFF	ON
9	EV9	OFF	ON	25	EV25	OFF	ON
10	EV10	OFF	ON	26	EV26	OFF	ON
11	EV11	OFF	ON	27	EV27	OFF	ON
12	EV12	OFF	ON	28	EV28	OFF	ON
13	EV13	OFF	ON	29	EV29	OFF	ON
14	EV14	OFF	ON	30	EV30	OFF	ON
15	EV15	OFF	ON	31	EV31	OFF	ON

Device Information

Device Name	pchportal		
Protocol	Profinet		
IP Address	192.168.1.8		
Bluetooth	OFF		
DHCP	Disabled		
Total Current Available	Logic	0.25 A	Aux <12 A
Maximum Current	Logic	8 A	Aux 12 A
Configuration Data Bytes	390		
Bytes Produced	500		
Bytes Consumed	492		
Serial Number	ABCD		

LED	Status	Value	Description
Aux Power	ON	24.49 V	Connected and within Limit
Logic Power	ON	24.56 V	Connected and within Limit
Bluetooth	OFF	-	OFF
Device Status	ON	-	Normal

LED	Status	Description
Port 1 LINK/Activity Status	ON	Link (100 Mbps) established
Port 2 LINK/Activity Status	OFF	No link, no activity
NS/ERR LED	OFF	---
MS/RUN LED	ON	---

● Output Configured ● Input ON ● IO-Link Configured, but no device connected ● IO-Link Configured, device connected
● Output Forced ON ● Output Forced OFF ● IO pin is short - circuited or faulted ● Output ON

Device connected ●

Figure 26 — Status Screen

Configuration Tool/Web Interface

5.1.2 Port Configuration Screen

The “Port Config” screen allows a user to view or change the pin configuration of PCH Portal. A User can make configuration changes from the pin images or from the “Port Configuration Detail” table.

Note: LED colours have different meanings between status and configuration screens.

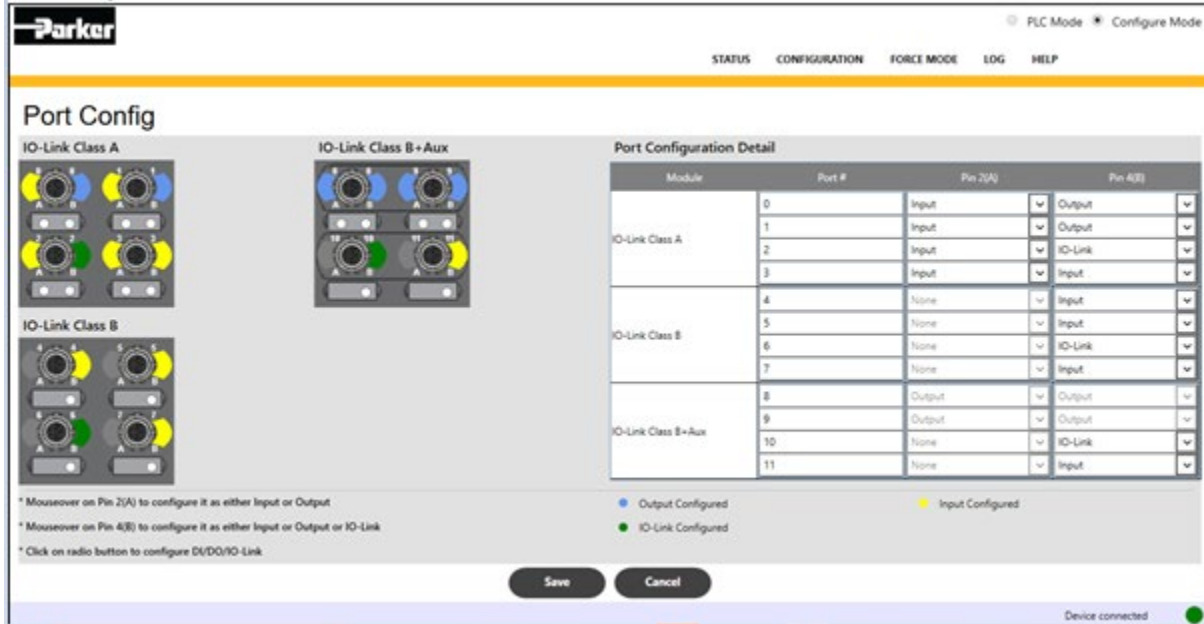

Figure 27 — Port Config Screen

Configuration Tool/Web Interface

5.1.3 Pin Config

The pin configuration can also be changed from the “Pin Config” tree structure. To see or change the configuration details of a particular Digital Input/Digital Output/IO-Link pin, select the appropriate respective radio button on the PCH Portal graphic in the “Port Config” screen.

Status

PCH10NABC0-P4

LED	Status	Value	Description
Aux Power	●	24.49 V	Connected and within Limit
Logic Power	●	24.52 V	Connected and within Limit
Bluetooth	●	-	OFF
Device Status	●	-	Normal

CONFIGURATION

Address	Valve Tag	Connect	State	Address	Valve Tag	Connect	State
0	EV0	OFF	●	16	EV16	OFF	●
1	EV1	OFF	●	17	EV17	OFF	●
2	EV2	OFF	●	18	EV18	OFF	●
3	EV3	OFF	●	19	EV19	OFF	●
4	EV4	OFF	●	20	EV20	OFF	●
5	EV5	OFF	●	21	EV21	OFF	●
6	EV6	OFF	●	22	EV22	OFF	●
7	EV7	OFF	●	23	EV23	OFF	●
8	EV8	OFF	●	24	EV24	OFF	●
9	EV9	OFF	●	25	EV25	OFF	●
10	EV10	OFF	●	26	EV26	OFF	●
11	EV11	OFF	●	27	EV27	OFF	●
12	EV12	OFF	●	28	EV28	OFF	●
13	EV13	OFF	●	29	EV29	OFF	●
14	EV14	OFF	●	30	EV30	OFF	●
15	EV15	OFF	●	31	EV31	OFF	●

Pin Configuration Tree:

- System Config
- Port Config
 - Pin 2(A)
 - Port0
 - Pin 4(B)
 - Port1
 - Port2
 - Port3
 - Port4
 - Port5
 - Port6
 - Port7
 - Port8
 - Port9
 - Port10
 - Port11
- Valve Config
- Node Config
- Pin Config
- IO-Link Config

Legend:

- Output Configured
- Input ON
- IO-Link Configured, but no device connected
- IO-Link Configured, device connected
- Output Forced ON
- Output Forced OFF
- IO pin is short - circuited or faulted
- Output ON

Device connected ●

Figure 28 — Pin Configuration Change

Configuration Tool/Web Interface

5.1.4 Digital Input Configuration Screen

User can see or change the below parameters in this screen:

- a. Description of Channel
- b. Digital Input Type
- c. Invert
- d. Debounce Time
- e. Cycle Warning Mode
- f. Cycle Count Type
- g. Upcounter cycle count notification limit/Downcounting preset to 0
- h. Cycle Reset

Digital Input All PNP All NPN Manual

i Description of Channel (Maximum of 20 characters)

Module Position

Channel Number

Digital Input Type

i Invert

i Debounce Time (0-120 ms)

i Cycle Warning Mode

Cycle Count

i Cycle Count Type

i Upcounter cycle count notification limit / Downcounting preset to 0

i Cycle Reset

i Mouseover on symbol for field description **!** Mouseover on symbol for warning description

Mouseover on field to see error text for invalid input

Save **Cancel** **Refresh**

Figure 29 — Digital Input Configuration Screen

Configuration Tool/Web Interface

5.1.5 Digital Output Configuration Screen

- a. Description of Channel
- b. Fault Mode
- c. Cycle Warning Mode
- d. Cycle Count Type
- e. Upcounter cycle count notification limit/Downcounting preset to 0
- f. Cycle Reset

Digital Output

i Description of Channel (Maximum of 20 characters)

Module Position 1

Channel Number 1

i Fault Mode ▾

i Cycle Warning Mode

Cycle Count 0

i Cycle Count Type ▾

i Upcounter cycle count notification limit / Downcounting preset to 0

i Cycle Reset

i Mouseover on symbol for field description **!** Mouseover on symbol for warning description

Mouseover on field to see error text for invalid input

Save **Cancel** **Refresh**

Figure 30 — Digital Output Configuration Screen

Configuration Tool/Web Interface

5.1.6 IO-Link Port Configuration Screen

- The live data from the connected IO-Link slave device is displayed under the “Device Information” section.
- The data in the “Optional Device Information” section is fetched when “Get Info” button is pressed.
- User can change the “Data Storage”, “Inspection Level” and “Cycle Time” from this screen as long as it is in “Configuration Mode”.
- User can read/write parameter data by entering the Index and Sub-Index in the “Parameter” section.
- User can see the cyclic input or can change the cyclic output from the “Process Data” section by selecting the “i” icon.
- The Parameter Content section displays the parameters and their respective data of the IO-Link slave device as long as the IODD file has been uploaded to the PCH Portal. Refer to 5.1.9 for IODD file management.
- “Read All” button reads all the parameter data from the connected IO-Link slave device and updates data into parameter content table.
- The “Data Storage” section at the bottom displays the “Device ID” and “Vendor ID” of the IO-Link slave device whose parameters have been uploaded on the current port.

IO-Link Port Configuration IO-Link Events

Device Information

Device ID	401152
Product Name	Parker Moduflex IO Link
Product ID	P2M2HBVL12400A (Class A) P2
Vendor Name	Parker Hannifin
Vendor ID	271
Serial Number	4217-0-0038
PD IN Length	1 Bytes
PD OUT Length	3 Bytes
Cycle Time	8.0 ms
Error Tag	No Error
Port #	3

Optional Device Information

Hardware rev	HW-V1.0
Firmware rev	FW-V1.10
Product Text	IOL V1.1.2 Connection
Application Tag	Parker
Vendor Text	Pneumatic Division

Process Data

Input	00
Output	00-00-00

Parameter

Data Storage Inspection Level

Index(dec) Sub Index(dec) Data Hex Dec Char

Data Size: 4 Bytes

0	0	
---	---	--

Read Write Apply Clear

Parameter Content (Name, Index(dec), Sub Index(dec), Data) Read All

Error with IO-Link device (refer to Error Tag) Mouseover on symbol for field description

Save Cancel Refresh

Figure 31 — IO Port Configuration Screen

Configuration Tool/Web Interface

5.1.7 IO-Link Events Screen

Events related to IO-Link are logged in the “IO-Link Events” screen of the respective IO-Link port. “The IO-Link Events” screen is accessed by selecting the “IO-Link Events” button as shown in Figure 32. User has to refresh this screen to see new logs. User can export these logs in CSV format. User can also clear the logs as long as they are in “Configuration Mode”.

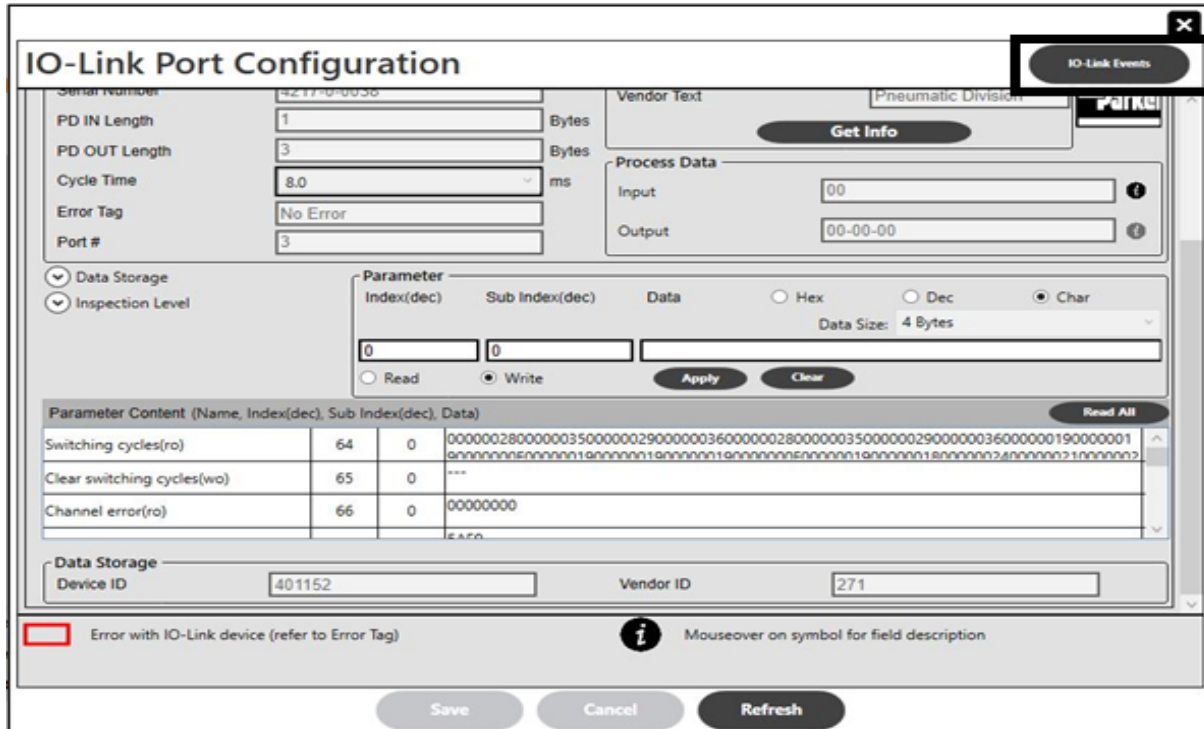

Figure 32 — Navigation to IO-Link Event

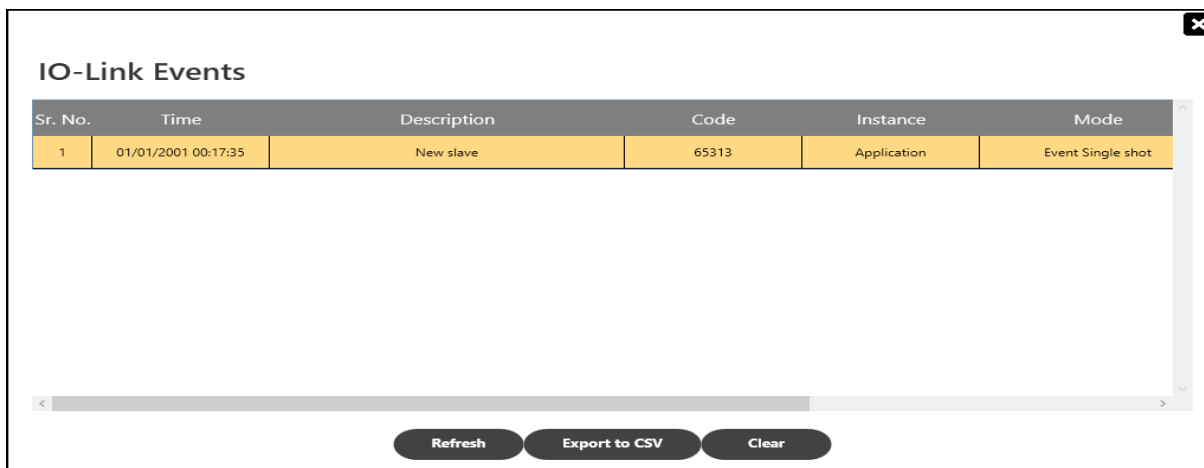

Figure 33 — IO-Link Event screen

NOTE:

- A maximum of 30 events are logged at a time.
- “Read All” button reads “Read only” and “Read Write” parameter data and updates into parameter content table as long as the IODD file has been uploaded to the PCH Portal. Refer to 5.1.9 for IODD file management.

Configuration Tool/Web Interface

5.1.8 Valve Configuration Screen

The “Valve Config” screen is used to change the configuration of any Valve. The following parameters of valves can be changed through Valve Config Screen:

- a. Valve Tag
- b. Fault Mode
- c. Cycle Warning mode
- d. Cycle Count Type
- e. Cycle Limit
- f. Cycle Reset

The screenshot displays the Parker Valve Config web interface. At the top, there is a navigation bar with the Parker logo on the left and mode selection on the right: 'PLC Mode' (unselected) and 'Configure Mode' (selected). Below the navigation bar are tabs for 'STATUS', 'CONFIGURATION', 'FORCE MODE', 'LOG', and 'HELP'. The main content area is titled 'Valve Config' and contains two side-by-side tables. Each table has five columns: 'Address', 'Valve Tag', 'Fault Mode', 'Cycle Warning Mode', and 'Cycle Count Type'. The left table lists valves from EV0 to EV15, and the right table lists valves from EV16 to EV31. In all instances, the 'Fault Mode' is 'LASTGOOD', the 'Cycle Warning Mode' is 'UPCOUN', and the 'Cycle Count Type' is 'UPCOUN'. Below the tables are three buttons: 'Save', 'Cancel', and 'Refresh'. At the bottom right, a status indicator shows 'Device connected' with a green dot.

Figure 34 — Valve Config

Configuration Tool/Web Interface

5.1.9 IODD Configuration Screen :

The “IODD Config” screen is used to upload an IODD file to the PCH Portal IODD library in the device or delete an IODD file from PCH Portal IODD library. IODD files are loaded into the IODD library regardless of what IO-Link port they are, or will be, connected to

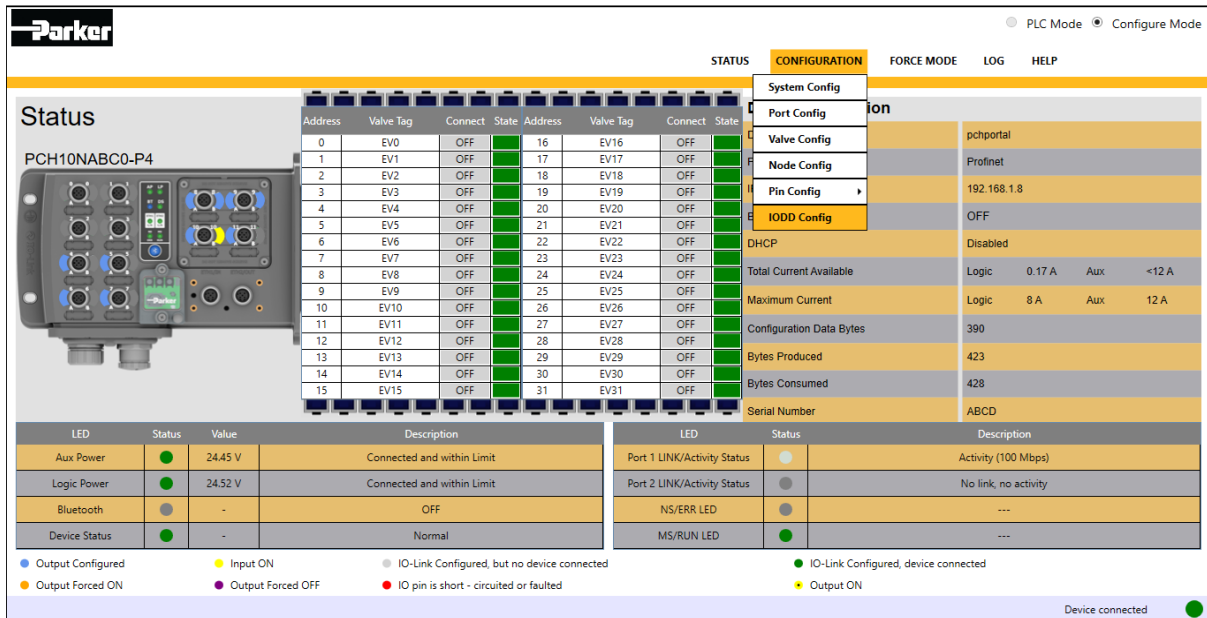

Figure 35 — Navigation to IODD config Screen

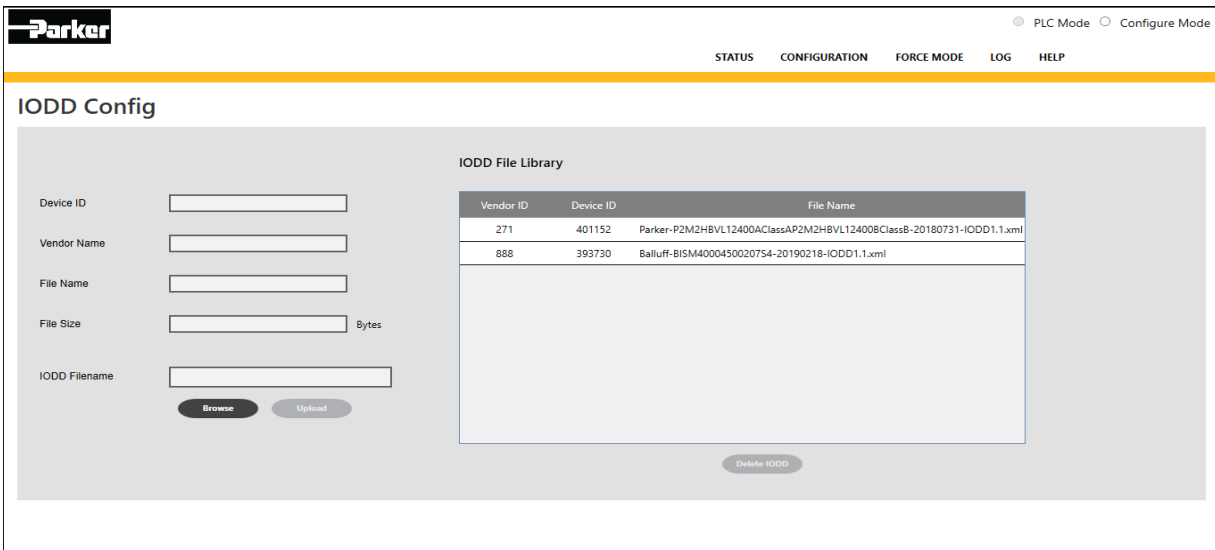

Figure 36 — IODD Config

NOTE:

- After uploading an IODD file, device image and vendor logo gets updated automatically, but in web interface user must upload the device image and vendor logo manually after uploading the IODD file.
- User does not need configuration access to upload/delete IODD files.
- User can upload maximum 12 IODD files into the PCH portal.

Configuration Tool/Web Interface

5.1.10 Force Mode Screen

To actuate DO/Valves of PCH Portal enter Force mode by clicking on “Force mode” tab, then click on the slider button and provide valid password. The default password is “parker”. Access to PCH Portal force mode will be granted if it is not already in force mode. User has to click on the radio buttons or on the Valve’s “Connect” column to actuate the Digital Outputs and Valves respectively.

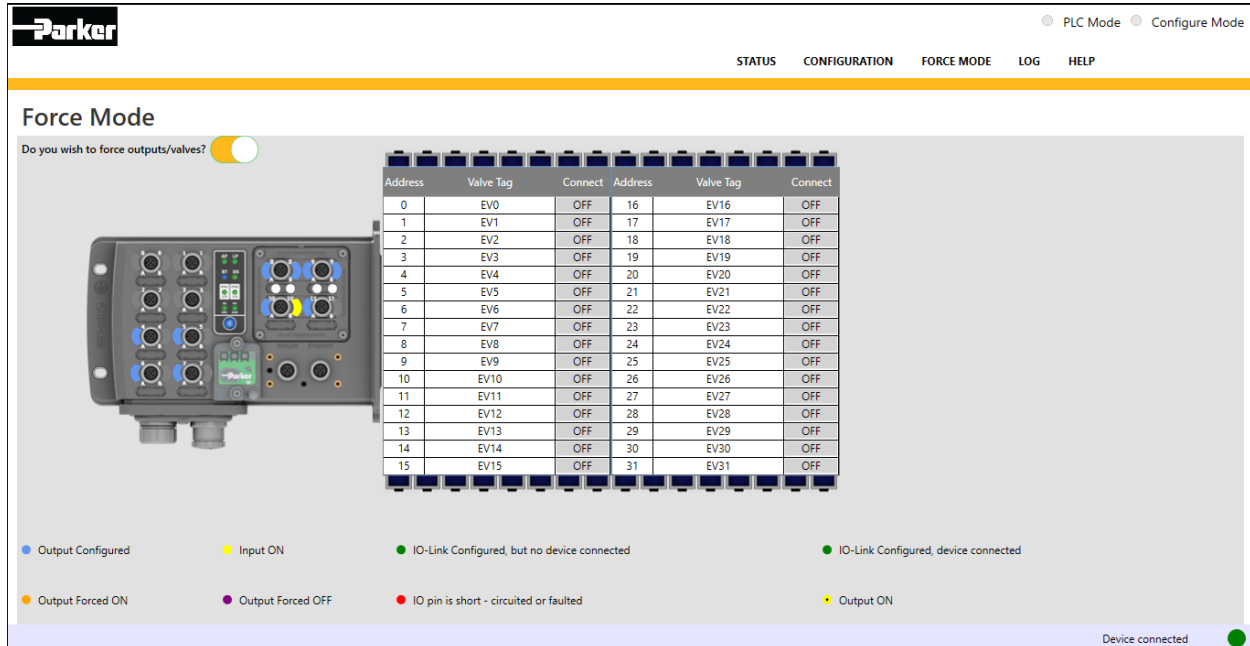

Figure 37 — Force Mode

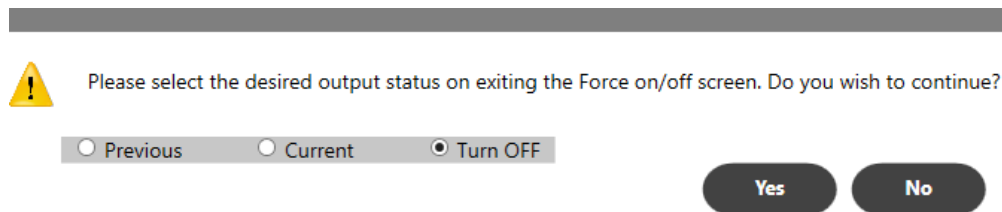

Figure 38 — Force ON/OFF Screen

On exiting the Force ON/OFF Screen, the user needs to select either Previous, Current, or Turn OFF option, which impacts Values and Digital Outputs.

5.1.11 Help Screen

User can click on the “HELP” tab to open the detailed GUI Help manual document.

Configuration Tool/Web Interface

5.1.12 System Configuration Screen

The “System Configuration” screen displays the system wide parameters such as date, time, network configuration addresses, MAC address, System ON Time, and Bluetooth configuration settings. Some of these parameters are user configurable in configuration mode.

QuickConnect Mode for Profinet – OFF, FSU (Fast Start Up)

Parker ● PLC Mode ● **Configure Mode**

STATUS CONFIGURATION FORCE MODE LOG HELP

System Configuration

Quick Connect Mode	OFF
Bluetooth	<input type="checkbox"/>
Bluetooth On Timer (1-20)	10 mins
System Up Time/ Hour Clock	0 hrs
Set System Date	08/21/2020
Set System Time	05:42:41 PM
Web Version	7.49
Firmware Package Version	05.62C

Network Configuration

IP Address	192 . 168 . 1 . 88
Subnet Mask	255 . 255 . 255 . 0
Default Gateway	192 . 168 . 1 . 1
DHCP	Disabled
MAC Address	00-30-11-1D-9E-6E
Station Name	pchportal

Device connected ●

Figure 39 — System Configuration

Configuration Tool/Web Interface

5.1.13 Node Configuration Screen

The “Node Configuration” page provides the capability to save the configuration of the PCH device to connected Windows PC, as well as to load the saved configuration from Windows PC to PCH device. It also provides the option to restore the PCH device to its factory default settings.

NOTE: In Restore to Factory Default option the PCH Portal device data will be cleared. It takes around 15 seconds to perform this operation. “Restore in Progress” is indicated via blinking cyan DS LED.

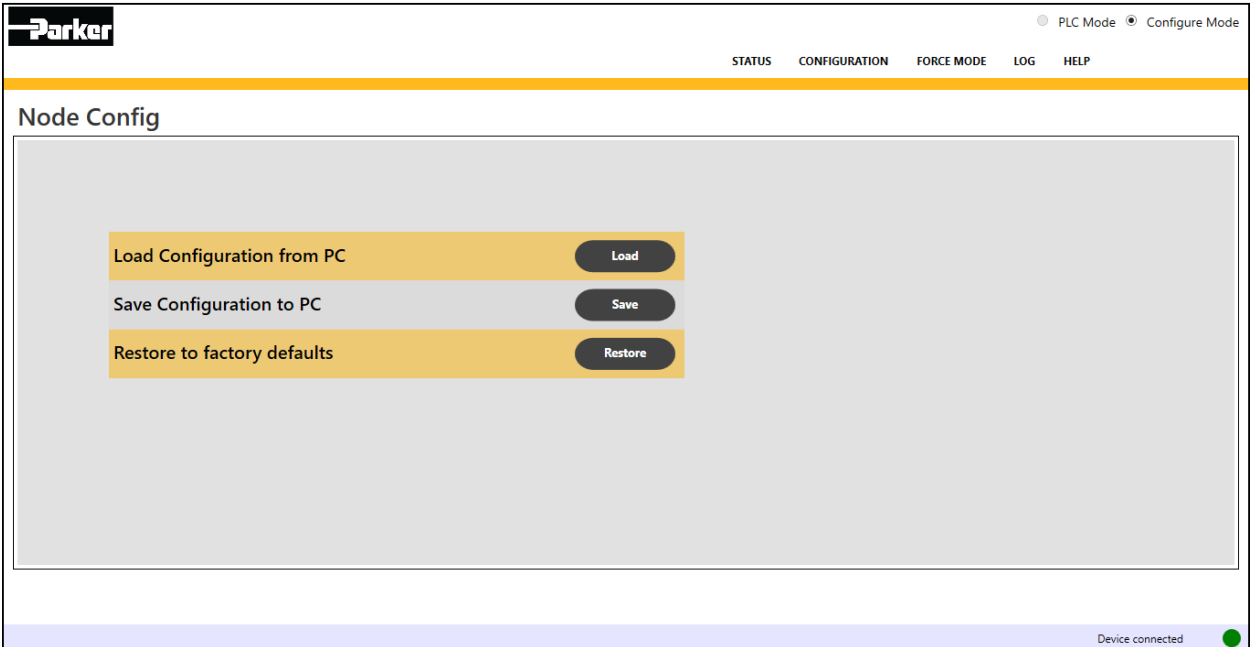

Figure 40 — Node Config

Configuration Tool/Web Interface

5.1.14 Logs Screen

The “LOGS” tab displays three options “Warnings”, “Events” and “Errors”. All the events provide time/date stamp details as well as module information. It also provides the user action required to recover from the Error and Events.

NOTE: A maximum of 40 events are logged at a time.

The screenshot shows the 'Errors' screen with the following table data:

Index	Date	Time	Module	Module Position	Description	Remarks
1	10/29/20	15:50:15	Logic Voltage	---	Low Voltage below 19.40V - [19.28V]	User needs to check the Logic voltage and take appropriate action to correct it. Once the Logic voltage sets to the normal working range device will reset the error indications to normal and log an event.
2	10/29/20	12:05:14	MS/Co-Proc	---	Database Initialization Failed	User can perform following options Option 1: Configuration download through utility or PLC Option 2: Replace the Device
3	10/29/20	11:54:38	MS/Co-Proc	---	Database Initialization Failed	User can perform following options Option 1: Configuration download through utility or PLC Option 2: Replace the Device

Additional UI elements include: Parker logo, mode selector (PLC Mode / Configure Mode), navigation menu (STATUS, CONFIGURATION, FORCE MODE, LOG, HELP), a search filter (10), pagination (1 of 1), and buttons for 'Export to CSV' and 'Refresh'. A status bar at the bottom indicates 'Device connected'.

Figure 41 — Errors Screen

The screenshot shows the 'Events' screen with the following table data:

Index	Date	Time	Module	Module Position	Description	Remarks
1	11/02/20	18:13:53	MS/Co-Proc	---	Configuration Updated	No Action Required
2	11/02/20	18:07:18	Network	---	Master/PLC Disconnected	User can perform following options Option 1: Check connection with Master/PLC and reconnect to PCH Portal if disconnected or halted
3	11/02/20	17:46:07	Network	---	Master/PLC Connected	No Action Required
4	11/02/20	17:46:07	MS/Co-Proc	---	Configuration Updated	No Action Required
5	11/02/20	16:28:41	MS/Co-Proc	---	Configuration Updated	No Action Required
6	11/02/20	16:26:51	MS/Co-Proc	---	Configuration Updated	No Action Required
7	11/02/20	16:26:51	MS/Co-Proc	---	Device Started !!!	No Action Required
8	10/30/20	21:41:36	MS/Co-Proc	---	Device Shutdown	No Action Required
9	10/30/20	21:27:05	MS/Co-Proc	---	Configuration Updated	No Action Required
10	10/30/20	21:27:05	MS/Co-Proc	---	Device Started !!!	No Action Required

Additional UI elements include: Parker logo, mode selector (PLC Mode / Configure Mode), navigation menu (STATUS, CONFIGURATION, FORCE MODE, LOG, HELP), a search filter (10), pagination (1 of 4), and buttons for 'Export to CSV' and 'Refresh'. A status bar at the bottom indicates 'Device connected'.

Figure 42 — Events Screen

Configuration Tool/Web Interface

The screenshot shows the Parker Configuration Tool/Web Interface. At the top, there is a navigation bar with 'STATUS', 'CONFIGURATION', 'FORCE MODE', 'LOG', and 'HELP'. The 'Configure Mode' is selected. Below the navigation bar, the 'Warnings' section is displayed. A dropdown menu shows '10'. The main content is a table with the following data:

Index	Date	Time	Module	Module Position	Description	Remarks
1	10/29/20	16:36:19	IO/IO-Link	001	DI 0 Cycle Count Limit Reached	User can perform following options Option 1: Need to replace corresponding DI - Sensor and Reset the cycle count
2	10/29/20	16:06:38	IO/IO-Link	001	DO 1 Cycle Count Limit Reached	User can perform following options Option 1: Need to replace corresponding DO - Actuator and Reset the cycle count
3	10/29/20	16:06:35	Valve	---	Valve 0 Cycle Count Limit Reached	User can perform following options Option 1: Need to replace corresponding Valve and Reset the cycle count
4	10/29/20	16:03:44	Valve	---	Valve 0 Cycle Count Limit Reached	User can perform following options Option 1: Need to replace corresponding Valve and Reset the cycle count
5	10/29/20	16:03:44	IO/IO-Link	001	DO 1 Cycle Count Limit Reached	User can perform following options Option 1: Need to replace corresponding DO - Actuator and Reset the cycle count
6	10/29/20	15:50:18	Logic Voltage	---	Low Voltage between 19.40V to 20.39V - [19.68V]	User needs to check the Logic voltage and take appropriate action to correct it. Once the Logic voltage sets to the normal working range device will reset the warning indications and log an event.
7	10/29/20	15:50:15	Auxiliary Voltage	---	Low Voltage between 19.40V to 20.39V - [20.28V]	User needs to check the Auxiliary voltage and take appropriate action to correct it. Once the Auxiliary voltage sets to the normal working range device will reset the warning indications to normal and log an event.
8	10/29/20	15:50:15	Logic Voltage	---	Low Voltage between 19.40V to 20.39V - [20.22V]	User needs to check the Logic voltage and take appropriate action to correct it. Once the Logic voltage sets to the normal working range device will reset the warning indications and log an event.
9	10/29/20	15:19:46	IO/IO-Link	003	IO-Link 10 - Validation Failure	User can perform following options Option 1: Need to replace IO-Link sensor with valid Vendor ID, Device ID and/or Serial

Below the table, there is a legend: * Module Positions: CPR - Co-Proc VAL - Valve BLT - Bluetooth N/W - Network. At the bottom right, there is a 'Device connected' status indicator with a green dot.

Figure 43 — Warnings screen

5.2 Bluetooth Mobile Application

The Bluetooth mobile application is also available to view status and configure the PCH Portal. This Bluetooth application is available for Android and iOS mobile devices and tablets. Please download the application from app store and install to your mobile device to get connected with PCH Portal over Bluetooth interface.

Please ensure Bluetooth communication of PCH Portal is turned ON before connecting . It can be turned on via configuration tool/web interface or by pressing Bluetooth button (and holding for more than 3 seconds) on Bluetooth module. Bluetooth LED flashes and turns solid when connected to the phone or tablet.

CHAPTER - 6 **Troubleshooting**

Troubleshooting

6.1 Troubleshooting

Table 38 — Troubleshooting Information

Description	Area/Module	Category	Event Log Message	Process Input Status Bits	User Actions
			Format: - Date Time Module Module Position Description		Note: The User Actions are displayed in Remark column for Log screen
Auxiliary Power - Low Voltage below 19.40V (Hysteresis 19.60V) Note: Under voltage cut-off: 14.70V Under voltage cut-off recovery: 15.70V	Auxiliary Voltage	Error	MM-DD-YY HRS:MIN:SEC Auxiliary Voltage --- Low Voltage below 19.40V - [<Actual Voltage>V]	Aux Voltage bit = 1 Error bit = 1	# User needs to check the Auxiliary voltage and take appropriate action to correct it. Once the Auxiliary voltage sets to the normal working range, the device resets the error indications to normal and log an event.
Auxiliary Power - Low Voltage between 19.40V and 20.40V (Hysteresis 19.60V to 20.60V)		Warning	MM-DD-YY HRS:MIN:SEC Auxiliary Voltage --- Low Voltage between 19.40V to 20.39V - [<Actual Voltage>V]	Aux Voltage bit = 1 Warning bit = 1	# User needs to check the Auxiliary voltage and take appropriate action to correct it. Once the Auxiliary voltage sets to the normal working range, the device resets the warning indications to normal and log an event.
Auxiliary Power - Voltage between 20.40V and 28.80V (Hysteresis 20.60V to 28.60V)		Event	MM-DD-YY HRS:MIN:SEC Auxiliary Voltage --- Normal Voltage between 20.40V to 28.80V - [<Actual Voltage>V]	NA	# No Action Required
Auxiliary Power - High Voltage between 28.80V and 29.50V (Hysteresis 28.60V to 29.30V)		Warning	MM-DD-YY HRS:MIN:SEC Auxiliary Voltage --- High Voltage between 28.81V to 29.50V - [<Actual Voltage>V]	Aux Voltage bit = 1 Warning bit = 1	# User needs to check the Auxiliary voltage and take appropriate action to correct it. Once the Auxiliary voltage sets to the normal working range, the device resets the warning indications to normal and log an event.
Auxiliary Power - High Voltage above 29.50V (Hysteresis 29.30V) Note: Overvoltage cut-off: 30.00 V Overvoltage cut-off recovery 29.50V		Error	MM-DD-YY HRS:MIN:SEC Auxiliary Voltage --- High Voltage above 29.50V - [<Actual Voltage>V]	Aux Voltage bit = 1 Error bit = 1	# User needs to check the Auxiliary voltage and take appropriate action to correct it. Once the Auxiliary voltage sets to the normal working range, the device resets the error indications to normal and log an event.
Logic Voltage below ~16.00V <Shutdown> Note: This event is not logged, only the indicators are mentioned wherever applicable Note: Under voltage cut-off: 14.70V Under voltage cut-off recovery: 15.70V	Logic Voltage	---	---	NA	# Power is below min limits; the unit does not power ON until voltage is above min limits
Logic Power - Low Voltage between below 19.40V (Hysteresis 19.60V)		Error	MM-DD-YY HRS:MIN:SEC Logic Voltage --- Low Voltage below 19.40V - [<Actual Voltage>V]	Logic Voltage bit = 1 Error bit = 1	# User needs to check the Logic voltage and take appropriate action to correct it. Once the Logic voltage sets to the normal working range, the device resets the error indications to normal and log an event.
Logic Power - Low Voltage between 19.40V and 20.40V (Hysteresis 19.60V to 20.60V)		Warning	MM-DD-YY HRS:MIN:SEC Logic Voltage --- Low Voltage between 19.40V to 20.39V - [<Actual Voltage>V]	Logic Voltage bit = 1 Warning bit = 1	# User needs to check the Logic voltage and take appropriate action to correct it. Once the Logic voltage sets to the normal working range, the device resets the warning indications and log an event.

Troubleshooting

Description	Area/Module	Category	Event Log Message	Process Input Status Bits	User Actions
			Format: - Date Time Module Module Position Description		Note: The User Actions are displayed in Remark column for Log screen
Logic Power -Voltage between 20.40V and 28.80V (Hysteresis 20.60V to 28.60V)	Logic Voltage	Event	MM-DD-YY HRS:MIN:SEC Logic Voltage --- Normal Voltage between 20.40V to 28.80V - [<Actual Voltage>V]	NA	# No Action Required
Logic Power - High Voltage above 28.80V (Hysteresis 28.60V)		Warning	MM-DD-YY HRS:MIN:SEC Logic Voltage --- High Voltage above 28.80V - [<Actual Voltage>V]	Logic Voltage bit = 1 Warning bit = 1	# User needs to check the Logic voltage and take appropriate action to correct it. Once the Logic voltage sets to the normal working range, the device resets the warning indications and log an event.
Logic Voltage above ~29.50V <Shutdown> Note: This event is not logged, only indicators are mentioned wherever applicable Note: Overvoltage cut-off: 30.00 V Overvoltage cut-off recovery: 29.50V		---	---	NA	# Power is above max limits; the device does not power ON until logic voltage is below max limits
Model Specification Mismatch Note: For this event no information is updated in any Data map for PLC. It is notified only through Device/Configuration Tool Indicators and Message Logging	MS/Co-Proc	Error	MM-DD-YY HRS:MIN:SEC MS/Co-Proc <Module Position> Model Specification Mismatch where <Module Position> for IO Modules is indicated as 001 - Module Position 1 002 - Module Position 2 003 - Module Position 3 and Other modules are indicated as N/W - Network Module (this indicates Protocol Mismatch) VAL - Valve Module	NA	# User can perform the following options: Option 1: Power Cycle the Device Option 2: Upgrade Firmware of the Device Option 3: Replace the IO Module as per configured Model Specification Option 4: Replace the Device
Device in Bootloader This occurs when device fails to jump from Boot mode to Application mode due to Application image corruption Note: This event is not logged, only indicators are mentioned wherever applicable		Error	---	NA	# User can perform the following options: Option 1: Upgrade Firmware of the Device Option 2: Replace the Device
Device Started		Event	MM-DD-YY HRS:MIN:SEC MS/Co-Proc --- Device Started	NA	No Action Required
Backplane Initialization Failed		Error	MM-DD-YY HRS:MIN:SEC MS/Co-Proc --- Backplane Initialization Failed	MS/CoProc bit = 1 Error bit = 1	# User can perform the following options: Option 1: Power Cycle the Device Option 2: Upgrade Firmware of the Device (i.e., to upgrade I/O module firmware) Option 3: Replace the Device
B40 Initialization Failed Note: For this event no information is updated in any Data map for PLC. It is notified only through Device/Configuration Tool Indicators and Message Logging		Error	MM-DD-YY HRS:MIN:SEC MS/Co-Proc --- N/W Module Initialization Failed	NA	# User can perform the following options: Option 1: Power Cycle the Device Option 2: Upgrade Firmware of N/W module through FTP Option 3: Replace the Device

Troubleshooting

Description	Area/Module	Category	Event Log Message	Process Input Status Bits	User Actions
			Format: - Date Time Module Module Position Description		Note: The User Actions are displayed in Remark column for Log screen
Database Initialization Failed	MS/Co-Proc	Error	MM-DD-YY HRS:MIN:SEC MS/Co-Proc --- Database Initialization Failed	MS/CoProc bit = 1 Error bit = 1	# User can perform the following options: Option 1: Configuration download through utility or PLC Option 2: Replace the Device
Device Shutdown		Event	MM-DD-YY HRS:MIN:SEC MS/Co-Proc --- Device Shutdown	NA	# No Action Required
Backplane Communication Break - <Warning>		Warning	MM-DD-YY HRS:MIN:SEC MS/Co-Proc --- Backplane Communication Break	MS/CoProc bit = 1 Warning bit = 1	# User can perform the following option: Option 1: Eliminate the Noise Source
Backplane Communication Break - <Fault>		Error	MM-DD-YY HRS:MIN:SEC MS/Co-Proc --- Backplane Communication Break	MS/CoProc bit = 1 Error bit = 1	# User can perform the following options: Option 1: Eliminate the Noise Source Option 2: Power Cycle the Device Option 3: Upgrade Firmware of the Device Option 4: Replace the Device
Backplane Communication Normal		Event	MM-DD-YY HRS:MIN:SEC MS/Co-Proc --- Backplane Communication Normal	NA	# No Action Required
Configuration Updated Note: This event occurs on any configuration change request from PCH Config Tool or through PLC		Event	MM-DD-YY HRS:MIN:SEC MS/Co-Proc --- Configuration Updated	NA	# No Action Required
Firmware Upgrade Started Note: In Application Mode this event is logged inclusive of Co-Proc Firmware Upgrade. In Boot Loader mode this event is logged excluding Co-Proc Firmware Upgrade since it is done through Boot Loader		Event	MM-DD-YY HRS:MIN:SEC MS/Co-Proc --- Firmware Upgrade Started	NA	# No Action Required
Firmware Upgrade Completed		Event	MM-DD-YY HRS:MIN:SEC MS/Co-Proc --- Firmware Upgrade Completed	NA	# No Action Required
Firmware Upgrade Failed Note: This event is limited to failure of IO-Module, Valve, Bluetooth and B40 firmware upgrade only, CoProc firmware upgrade is excluded from this event since it's firmware upgrade is done through Boot Loader		Error	MM-DD-YY HRS:MIN:SEC MS/Co-Proc <Module Position> Firmware Upgrade Failed where <Module Position> for IO Modules is indicated as 001 - Module Position. 1 002 - Module Position. 2 003 - Module Position. 3 and <Module Position> for Other modules it is indicated as VAL - Valve Module BLT - Bluetooth Module N/W - Network Module	NA	# User can perform the following options: Option 1: Power Cycle the Device Option 2: Upgrade Firmware of the Device Option 3: Replace the Device

Troubleshooting

Description	Area/Module	Category	Event Log Message	Process Input Status Bits	User Actions
			Format: - Date Time Module Module Position Description		Note: The User Actions are displayed in Remark column for Log screen
<p>Watch Dog Expired (for Count > 1 and < 5)</p> <p>Note: In case of Remote modules (i.e., Valve and I/Os) this event can only be logged if event notifying logic of these modules to Co-Proc is not hanged</p>	MS/Co-Proc	Warning	<p>MM-DD-YY HRS:MIN:SEC MS/Co-Proc <Module Position> Watch Dog Expired</p> <p>where <Module Position> for IO Modules is indicated as 001 - Module Position. 1 002 - Module Position. 2 003 - Module Position. 3 and <Module Position> for Other modules is indicated as CPR- Co-Proc Module VAL - Valve Module</p>	MS/CoProc bit = 1 Warning bit = 1	# User can perform the following options: Option 1: Power Cycle the Device Option 2: Upgrade Firmware of specified module
<p>Watch Dog Expired (for Count >= 5)</p> <p>Note: In case of Remote modules (i.e., Valve and I/Os) this event can only be logged if event notifying logic of these modules to Co-Proc is not hanged</p>		Error	<p>MM-DD-YY HRS:MIN:SEC MS/Co-Proc <Module Position> Watch Dog Expired</p> <p>where <Module Position> for IO Modules is indicated as 001 - Module Position. 1 002 - Module Position. 2 003 - Module Position. 3 and <Module Position> for Other modules it is indicated as CPR- Co-Proc Module VAL - Valve Module</p>	MS/CoProc bit = 1 Error bit = 1	# User can perform the following options: Option 1: Power Cycle the Device Option 2: Upgrade Firmware of specified module Option 3: Replace the Device
<p>SPI Communication - B40 <Warning></p> <p>Note: For this event no information is updated in any Data map for PLC. It is notified only through Device/Configuration Tool Indicators and Message Logging</p>		Warning	MM-DD-YY HRS:MIN:SEC MS/Co-proc --- N/W Module - SPI Communication Break	NA	# User can perform the following options: Option 1: Restart the device Option 2: Upgrade Firmware of N/W through FTP Option 3: Replace the Device
<p>SPI Communication - B40 Normal</p>		Event	MM-DD-YY HRS:MIN:SEC MS/Co-proc --- N/W Module - SPI Communication Normal	NA	# No Action Required
<p>RTC VBAT not available</p>		Warning	MM-DD-YY HRS:MIN:SEC MS/Co-proc --- RTC VBAT not available	NA	# User can perform the following options: Option 1: Power Cycle the Device Option 2: Insert/Replace the RTC Battery Option 3: Replace the Device
<p>Invalid Configuration from PLC</p> <p>Note: For this event no information is updated in any Data map for PLC. It is notified only through Device/Configuration Tool Indicators and Message Logging</p>		Warning	MM-DD-YY HRS:MIN:SEC MS/Co-proc --- Invalid Configuration from PLC	NA	# User can perform the following options: Option 1: Set correct configuration through PLC

Troubleshooting

Description	Area/Module	Category	Event Log Message	Process Input Status Bits	User Actions
			Format: - Date Time Module Module Position Description		Note: The User Actions are displayed in Remark column for Log screen
Auxiliary Current - Current till 12 Amps	Auxiliary Current	Event	MM-DD-YY HRS:MIN:SEC Auxiliary Current --- Normal Auxiliary Current till 12Amps	NA	# No Action Required
Auxiliary Current - Current above 12 Amps Note: - HW Cut-Off is at 12.7 Amps		Error	MM-DD-YY HRS:MIN:SEC Auxiliary Current --- High Auxiliary Current above 12Amps	Aux Current bit = 1 Error bit = 1	# User can perform the following options: Option 1: Power Cycle the Device Option 2: Replace the Device
Logic Current - Current till 7.5 Amps	Logic Current	Event	MM-DD-YY HRS:MIN:SEC Logic Current --- Normal Logic Current till 7.5Amps - [<Actual Current>Amps]	NA	# No Action Required
Logic Current - Current between 7.5 Amps to 8 Amps		Warning	MM-DD-YY HRS:MIN:SEC Logic Current --- High Logic Current between 7.5Amps to 8Amps - [<Actual Current>Amps]	Logic Current bit = 1 Warning bit = 1	# User can perform the following option: Option 1: Power Cycle the Device
Logic Current - Current above 8 Amps		Error	MM-DD-YY HRS:MIN:SEC Logic Current --- High Logic Current above 8Amps - [<Actual Current>Amps]	Logic Current bit = 1 Error bit = 1	# User can perform the following options: Option 1: Power Cycle the Device Option 2: Replace the Device
Temperature till 75 °C	Temperature	Event	MM-DD-YY HRS:MIN:SEC Temperature Warning --- Normal Temperature till 75 °C - [<Actual Temperature>°C]	NA	# No Action Required
Temperature between 75 °C to 80 °C		Warning	MM-DD-YY HRS:MIN:SEC Temperature Warning --- High Temperature between 75 °C to 80 °C - [<Actual Temperature>°C]	Temperature Warning bit = 1 Warning bit = 1	# User can perform the following options: Option 1: Eliminate the Increasing Temperature Source Option 2: Power Cycle the Device
Temperature above 80 °C		Error	MM-DD-YY HRS:MIN:SEC Temperature Warning --- High Temperature above 80 °C - [<Actual Temperature>°C]	Temperature Warning bit = 1 Error bit = 1	# User can perform the following options: Option 1: Eliminate the Increasing Temperature Source Option 2: Power Cycle the Device Option 3: Replace the Device
Cycle Count Limit Reached	Valve	Warning	MM-DD-YY HRS:MIN:SEC Valve --- Valve <Valve No> Cycle Count Limit Reached where <Valve No> varies from 0 to 31	Target Count bit = 1 Warning bit = 1	# User can perform the following option: Option 1: Need to replace corresponding Valve and reset cycle count (Acyclic Data Map - B22.0 to B25.7) Note: The corresponding bits are set for 2 seconds

Troubleshooting

Description	Area/Module	Category	Event Log Message	Process Input Status Bits	User Actions
			Format: - Date Time Module Module Position Description		Note: The User Actions are displayed in Remark column for Log screen
Short Circuit	Valve	Error	MM-DD-YY HRS:MIN:SEC Valve --- Valve <Valve No> in Fault State where <Valve No> varies from 0 to 31	Valve bit = 1 Error bit = 1 VF00 - VF31 bit = 1 (Valve fault status) w.r.t corresponding valve	# User can perform the following option: Option 1: Need to remove short circuit by replacing Valve
SPI Communication/ Auxiliary Power Supply - Valve Driver <Warning>		Warning	MM-DD-YY HRS:MIN:SEC Valve --- Valve Driver <Valve Driver No.> - SPI Communication Break/ Auxiliary Supply Fault where <Valve Driver No> varies from 1 to 4	Valve bit = 1 Warning bit = 1	# User can perform the following option: Option 1: Check Auxiliary Power Supply Option 2: Eliminate the Noise Source
EEPROM Corruption		Error	MM-DD-YY HRS:MIN:SEC Valve --- EEPROM Corrupted	Valve bit = 1 Error bit = 1	# User can perform the following options: Option 1: Power Cycle the Device Option 2: Replace the Device
SPI Communication/ Auxiliary Power Supply - Valve Driver <Fault>		Error	MM-DD-YY HRS:MIN:SEC Valve --- Valve Driver <Valve Driver No.> - SPI Communication Break/ Auxiliary Supply Fault where <Valve Driver No> varies from 1 to 4	Valve bit = 1 Error bit = 1	# User can perform the following options: Option 1: Check Auxiliary Power Supply Option 2: Eliminate Noise Source Option 3: Power Cycle the Device Option 4: Replace the Device
I2C Communication - EEPROM <Fault>		Error	MM-DD-YY HRS:MIN:SEC Valve --- EEPROM - I2C Communication Break	Valve bit = 1 Error bit = 1	# User can perform the following options: Option 1: Power Cycle the Device Option 2: Replace the Device
Cycle Count Limit Reached - DI	IO/IO-Link	Warning	MM-DD-YY HRS:MIN:SEC IO/IO-Link <Module Position> DI <Channel No> Cycle Count Limit Reached where <Channel No.> varies from 0 to 23	Target Count bit = 1 Warning bit = 1	# User can perform the following option: Option 1: Need to replace corresponding DI - Sensor and Reset the cycle count (Acyclic Data Map - B49.0 to B51.7) Note: The corresponding bits must be set for 2 sec
Cycle Count Limit Reached - DO		Warning	MM-DD-YY HRS:MIN:SEC IO/IO-Link <Module Position> DO <Channel No> Cycle Count Limit Reached where <Channel No> varies from 0 to 23	Target Count bit = 1 Warning bit = 1	# User can perform the following options: Option 1: Need to replace the corresponding DO - Actuator and Reset the cycle count (Acyclic Data Map - B69.0 to B71.7) Note: The corresponding bits are set for 2 seconds
Short to GND or Overload at Pin 2 and Pin 4 of M12		Error	MM-DD-YY HRS:MIN:SEC IO/IO-Link <Module Position> Over Current at Channel No. <Channel No> where <Channel No> varies from 0 to 23	IO/IO-Link bit = 1 Error bit = 1 OC bit = 1 OC 1,2 or 3 bit = 1 overcurrent w.r.t corresponding I/O module	# User can perform the following option: Option 1: Need to remove short circuit and Power Cycle the Device

Troubleshooting

Description	Area/Module	Category	Event Log Message	Process Input Status Bits	User Actions
			Format: - Date Time Module Module Position Description		Note: The User Actions are displayed in Remark column for Log screen
Electronic fuse trip at Pin 1 of M12 due thermal/current overload/ Short Circuit	IO/IO-Link	Error	MM-DD-YY HRS:MIN:SEC IO/IO-Link <Module Position> Logic Supply Overload	IO/IO-Link bit = 1 FS bit = 1 Error bit = 1	# User can perform the following option: Option 1: Need to remove short circuit
IO Module configuration and its relevant configuration in Co-Proc Mismatches		Warning	MM-DD-YY HRS:MIN:SEC IO/IO-Link <Module Position> IO Configuration Mismatch	IO/IO-Link bit = 1 Warning bit = 1	# It is auto corrected by Co-Proc at Start-up by default configuration in IO Module
I2C Communication - ADC <Warning>		Warning	MM-DD-YY HRS:MIN:SEC IO/IO-Link <Module Position > ADC - I2C Communication Break	IO/IO-Link bit = 1 Warning bit = 1	# User can perform the following option: Option 1: Eliminate the Noise Source
USART Communication - IO-Link Transceiver <Warning>		Warning	MM-DD-YY HRS:MIN:SEC IO/IO-Link <Module Position> IO-Link Transceiver - USART <USART No> Communication Break where <USART No> varies from 0 to 3	IO/IO-Link bit = 1 Warning bit = 1	# User can perform the following option: Option 1: Eliminate the Noise Source
External Flash Corruption		Error	MM-DD-YY HRS:MIN:SEC IO/IO-Link <Module Position> External Flash Corrupted	IO/IO-Link bit = 1 Error bit = 1	# User can perform the following options: Option 1: Power Cycle the Device Option 2: Replace the Device
I2C Communication - ADC <Fault>		Error	MM-DD-YY HRS:MIN:SEC IO/IO-Link <Module Position> ADC - I2C Communication Break	IO/IO-Link bit = 1 Error bit = 1	# User can perform the following options: Option 1: Eliminate the Noise Source Option 2: Power Cycle the Device Option 3: Replace the Device
SPI Communication - IO-Link Transceiver <Fault>		Error	MM-DD-YY HRS:MIN:SEC IO/IO-Link <Module Position> IO-Link Transceiver - SPI Communication Break	IO/IO-Link bit = 1 Error bit = 1	# User can perform the following options: Option 1: Power Cycle the Device Option 2: Replace the Device
USART Communication - IO-Link Transceiver <Fault>		Error	MM-DD-YY HRS:MIN:SEC IO/IO-Link <Module Position> IO-Link Transceiver - USART <USART No> Communication Break where <USART No> varies from 0 to 3	IO/IO-Link bit = 1 Error bit = 1	# User can perform the following options: Option 1: Eliminate the Noise Source Option 2: Power Cycle the Device Option 3: Replace the Device

Troubleshooting

Description	Area/Module	Category	Event Log Message	Process Input Status Bits	User Actions
			Format: - Date Time Module Module Position Description		Note: The User Actions are displayed in Remark column for Log screen
IO-Link - Validation Failure	IO/IO-Link	Warning	MM-DD-YY HRS:MIN:SEC IO/IO-Link <Module Position> IO-Link <Port No> - Validation Failure where <Port No> varies from 0 to 11	Refer to Table 28	# User can perform the following options: Option 1: Need to replace IO-Link sensor with valid Vendor ID, Device ID and/or Serial Number Option 2: Reconfigure Port to No Validation
IO-Link - Short Circuit		Error	Note: This is logged as part of IO-Link Events	Refer to Table 28	# User can perform the following option: Option 1: Need to remove short circuit by replacing IO-Link Sensor
IO-Link - Data Storage Error		Warning	Note: This is logged as part of IO-Link Events	Refer to Table 28	# User can perform the following options: Option 1: Need to replace the IO-Link sensor with matching Device ID and Vendor ID of data storage Option 2: Reconfigure Port to Disable/ Clear Data Storage
IO-Link - Process Data Invalid		Error	MM-DD-YY HRS:MIN:SEC IO/IO-Link <Module Position> IO-Link <Port No> - Process Data Invalid where <Port No> varies from 0 to 11	Refer to Table 28	# User can perform the following option: Option 1: Connect the IO-Link sensor
IO-Link - Device Communication Lost		Error	Note: This is logged as part of IO-Link Events	Refer to Table 28	# User can perform the following option: Option 1: Connect the IO-Link sensor
Invalid IP Address - Rotary Switch Out of Range	Network	Warning	MM-DD-YY HRS:MIN:SEC Network --- Invalid IP Address - Rotary Switch Out of Range	Network Bit = 1 Warning Bit = 1	# User can perform the following option: Option 1: Set the correct IP address by setting the Rotary Switch value within valid range
PLC - Output Access Disabled		Warning	MM-DD-YY HRS:MIN:SEC Network --- PLC - Output Access - Output Access Disabled	Network Bit = 1 Warning Bit = 1	# User can perform the following options: Option 1: Change Device Ownership since PLC is not the current owner of the device. Owner change options: 1. Exit Configure Mode of PCH Config Utility/Webserver/Bluetooth App 2. Exit Valve Testing Mode 3. Exit FTP Mode
# Master/PLC connected Online (RUN)	Network - PROFINET	Event + B40	MM-DD-YY HRS:MIN:SEC Network --- Master/PLC Connected	NA	# No Action Required
# Master/PLC disconnected		Event + B40	MM-DD-YY HRS:MIN:SEC Network --- Master/PLC Disconnected	NA	# User can perform the following option: Option 1: Check connection with Master/PLC and reconnect to PCH Portal if disconnected or halted

CHAPTER - 7 **Abbreviation List**

Abbreviation List

7.1 Abbreviations

Table 39 — Abbreviations List

Acronym	Definition
ADC	Analog to Digital Converter
AP	Auxiliary Power
AUX	Auxiliary
BLE	Bluetooth Low Energy
BT	Bluetooth Module Status/Bluetooth
CH	Channel
Comm	Communication
DBT	De-bounce Time
DI	Digital Input
DID	Device ID
DIN	Digital Inversion
DIO	Digital Input Output
DIP	Dual In-line Package
DO	Digital Output
DS	Device Status
FM	Fault Mode
FS	Fuse Status
GND	Ground
IO	Input Output
IP	Internet Protocol
IP65	Ingress Protection 65
LED	Light Emitting Diode
LOG	Logic
LP	Logic Power
MS	Module Status
NS	Network Status
OTG	On-The-Go
PCH	Parker Communication for H-Series
PLC	Programmable Logic Controller
RESV	Reserved
USB	Universal Serial Bus
VAUX	Auxiliary Voltage
VID	Vendor ID
VLOG	Logic Voltage

CHAPTER - 8 **Appendix**



Appendix

8.1 IO-Link Events

8.1.1 IO-Link Event Qualifier:

The following list of tables indicates the permissible values for various fields of Event Qualifier.

Table 40 — Permissible Values for Instances

Definition	Value
Unknown	0
Reserved	1 to 3
Application	4
Reserved	5 to 7

Table 41 — Permissible Values for Source

Definition	Value
Device (remote)	0
Master (local)	1

Table 42 — Permissible Values for Event Type

Definition	Value
Reserved	0
Notification	1
Warning	2
Error	3

Table 43 — Permissible values for mode

Definition	Value
Reserved	0
Event single shot	1
Event disappears	2
Event appears	3

Appendix

8.1.2 IO-Link Event Codes

The following table lists the PCH Portal specific events Refer to IO-Link Specification for the Events defined by IO-Link Standard. For Events generated by IO-Link Slave device, refer to the same document.

Table 44 — PCH Portal specific events

Event Code	Event Description
0xC101	Overtemperature Shutdown Level event error code
0xC102	Overtemperature Warning Level event error code
0xC103	Vdd Supply 0V event error code
0xC104	Vdd Supply UV event error code
0xC105	Vdd Supply UVLO event error code
0xC106	VL Supply UVLO event error code
0xC107	Wake-up event error code
0xC108	L+ Overcurrent Timeout event error code
0xC109	L+ Power Changed event error code
0xC10A	CQ Overcurrent Timeout event error code
0xC10B	CSense event error code
0xC201	Data Storage EEPROM access error code

Appendix

8.2 Power Consumption Chart

Table 45 — Power Consumption

Module Config	Logic Power			Auxiliary Power				
	Theoretical Max Module Power Draw	Power Available for PCH Network Portal	Power Available for Pass Through	Theoretical Max Module Power Draw	Power Available after Module Draw	Valve Power Draw	Power Available for PCH Network Portal	Power Available for Pass Through
	Logic (A)	Logic (A)	Logic (A)	Aux (A)	Aux (A)	Aux (A)	Aux (A)	Aux (A)
AAA	8.000	0.000	12.000	4.256	7.744			
AAB	6.000	2.000	14.000	9.056	2.944			
AAC	7.500	0.500	12.500	8.656	3.344			
AAN	6.000	2.000	14.000	4.256	7.744			
ABB	4.000	4.000	16.000	12.000	0.000			
ABC	6.000	2.000	14.000	12.000	0.000			
ABN	5.000	3.000	15.000	9.056	2.944			
ACC	7.000	1.000	13.000	12.000	0.000			
ACN	5.500	2.500	14.500	8.656	3.344			
BBB	5.000	3.000	15.000	12.000	0.000			
BBC	3.500	4.500	16.500	12.000	0.000			
BBN	2.000	6.000	18.000	12.000	0.000			
BCC	4.000	4.000	16.000	12.000	0.000			
BCN	2.500	5.500	17.500	12.000	0.000			
CCC	4.500	3.500	15.500	12.000	0.000			
CCN	3.000	5.000	17.000	12.000	0.000			

NOTE: “To obtain ‘Power Available for PCH Network Portal’, subtract ‘Valve Power Draw’ from ‘Power Available after Module Draw’. To obtain ‘Power Available for Pass Through’, subtract 20 A by ‘Power Available for PCH Network Portal’”.

Appendix

8.3 Ordering Information

The part number written on the label for the PCH Network Portal can be understood using the below model number structure.

IMPORTANT: This part number **cannot** be purchased from the factory. In order to purchase a PCH Network Portal, refer to the published catalogue of the PCH Network Portal for the full end plate kit part number. This can be found at the product landing page:

<https://ph.parker.com/us/17571/en/pch-network-portal/pch-portal>

For any questions, please contact pdnapps@parker.com.

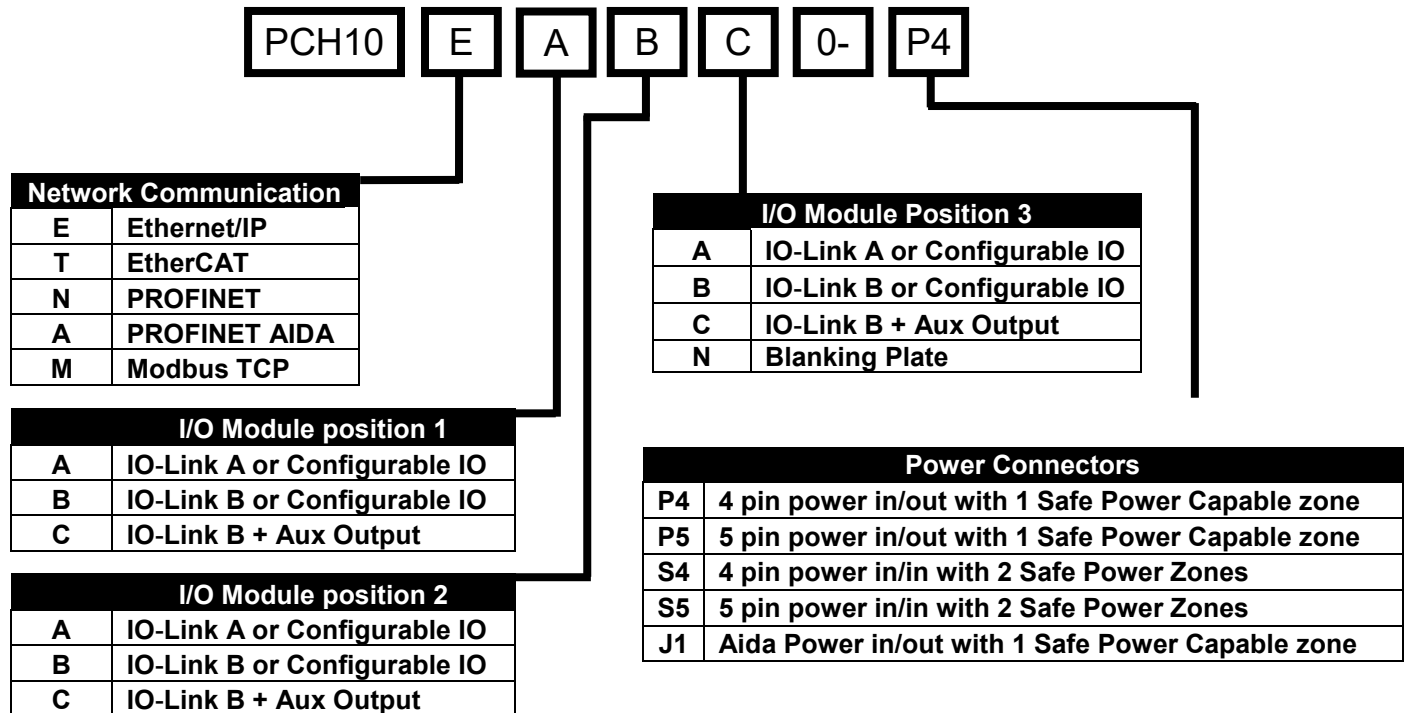

8.4 Connectivity and Integration Support

Network Connectivity Site

<https://promo.parker.com/promotionsite/network-connectivity/us/en/home>



Network Connectivity – Resource Library

http://solutions.parker.com/PDN_NetworkConnectivityResourceLibrary

Network Connectivity – Software Files

http://solutions.parker.com/PDN_softwarefiles

Parker Hannifin Corporation

Pneumatic Division

Americas USA, Canada, Mexico

c-parker@parker.com

1-800-272-7537