

ENGINEERING **YOUR** SUCCESS.

## PCH NETWORK PORTAL (MODBUS)

PCH1xMxxxx-Px



# User Manual

Document Number: 1610PDN.04UM.00

Effective: Dec. 2020

© 2020 Parker Hannifin Corporation  
All Rights Reserved.



# Table of Contents

## Table of Contents

	Page
CHAPTER - 1 General.....	5
1.1 Trademark Information .....	6
1.2 About this Guide .....	6
1.3 Safety Information.....	6
1.4 Important User Information.....	7
1.5 Intended Use .....	7
1.6 Service Information.....	7
1.7 Assumptions of Technical Experience.....	8
1.8 Product Naming .....	8
1.9 Notes, Cautions and Warnings.....	8
CHAPTER - 2 Overview .....	9
2.1 Product Overview .....	10
2.2 Module Overview .....	11
2.3 Power Supply Connectors .....	12
2.4 Grounding .....	15
2.5 I/O and IO-Link .....	16
2.6 Status LEDs/Bluetooth Enable Button.....	19
2.7 USB connector and Rotary Switches .....	21
2.8 Network Communication Ports NT1 and NT2 .....	23
2.9 Connection to H Universal Air Supply .....	23
2.10 Port and Port LED Descriptions.....	27
2.11 IO Port LED Indication.....	28
CHAPTER - 3 Technical Data .....	29
3.1 Dimensions .....	30
3.2 Mechanical Data .....	31
3.3 Operating Conditions .....	31
3.4 Electrical Data.....	31
CHAPTER - 4 PCH Portal Function .....	32
4.1 Modbus-TCP Functions .....	33
4.2 Modbus Data Registers Mapping .....	34
4.3 Configuration Data.....	35
4.3.1 Process Active Timeout .....	35
4.3.2 Parametrization .....	35
4.3.3 Port Configuration .....	36
4.3.4 Configuration of DI and DO Control Parameter .....	37
4.3.4.1 DO Fault Mode .....	38

# Table of Contents

4.3.4.2	DIO Counter Control .....	38
4.3.4.3	DIO Counter Type .....	38
4.3.4.4	DI Inversion .....	38
4.3.4.5	De-Bounce Time .....	39
4.3.5	Configuration of Valve Parameters .....	39
4.3.5.1	Valve Fault Mode .....	39
4.3.5.2	Valve Counter Control .....	39
4.3.5.3	Valve Counter Type .....	40
4.3.6	Configuration of IO-Link Port Parameters .....	40
4.3.6.1	Data Storage .....	42
4.3.6.2	Validation Type .....	42
4.3.6.3	Cycle Time .....	42
4.4	Process Data Inputs .....	44
4.4.1	Device Status Bytes .....	44
4.4.1.1	Status Bytes .....	45
4.4.1.2	Fuse and Over Current Status .....	45
4.4.1.3	Valve Fault Status .....	45
4.4.2	IO-Link Status Bytes .....	45
4.4.3	Standard Discrete Inputs .....	46
4.4.4	IO-Link Input Process Data .....	46
4.5	Process Data Outputs .....	47
4.5.1	Standard Discrete Output and Device Control .....	47
4.5.1.1	Standard Output (O0A to O11B) .....	47
4.5.1.2	Device Control .....	47
4.5.2	Valve Outputs .....	48
4.5.2.1	Valve Outputs (V00 to V31) .....	48
4.5.3	IO-Link Output Process Data .....	48
4.6	Diagnostics .....	49
4.7	Acyclic Communication .....	50
4.7.1	Auxiliary and Logic Voltage .....	53
4.7.2	MS/Co-Proc .....	53
4.7.3	Valve .....	54
4.7.4	Digital Inputs .....	54
4.7.5	Digital Outputs .....	55
4.7.6	I/O/IO-Link .....	55
4.7.7	Network .....	55
4.8	A Module cyclic Services .....	56
4.8.1	A Module cyclic Read Service .....	56
4.8.2	A Module cyclic Write Service .....	57

# Table of Contents

4.9	IO-Link Events .....	58
CHAPTER - 5	Configuration Tool/Web Interface .....	60
5.1	The PC Configuration Tool/Web Interface .....	61
5.1.1	Status Screen.....	65
5.1.2	Port Configuration Screen.....	66
5.1.3	Pin Config.....	67
5.1.4	Digital Input Config Sreen .....	68
5.1.5	Digital Output Configuration Screen.....	69
5.1.6	IO-Link Port Configuration Screen .....	70
5.1.7	IO-Link Events Screen .....	71
5.1.8	Valve Configuration Screen .....	72
5.1.9	IODD Configuration Screen .....	73
5.1.10	Force Mode Screen.....	74
5.1.11	Help Screen.....	74
5.1.12	System Configuration Screen .....	75
5.1.13	Node Configuration Screen.....	76
5.1.14	Logs Screen .....	77
5.2	Bluetooth Mobile Application .....	78
CHAPTER - 6	Troubleshooting.....	79
6.1	Troubleshooting .....	80
CHAPTER - 7	Abbreviation List.....	89
7.1	Abbreviations .....	90
CHAPTER - 8	Appendix .....	91
8.1	Process Input Data Registers.....	92
8.2	Process Output Data Registers .....	95
8.3	IO-Link Events .....	97
8.3.1	IO-Link Event Qualifier .....	97
8.3.2	IO-Link Event Codes .....	98
8.4	Power Consumption Chart .....	99
8.5	Ordering information.....	100
8.6	Connectivity and Integration Support .....	100

CHAPTER - 1 **General**

# General

## 1.1 Trademark Information

MODBUS® is a registered trademark of Schneider Electric USA, Inc.

## 1.2 About this Guide

This user guide is intended for those who are responsible for installing, configuring, and troubleshooting PCH Portal and its associated software and accessories.

## 1.3 Safety Information

Please read and follow all the safety information for the Parker Communication for H-Series (PCH) Portal, including the warning and caution statements in this guide, before installing or operating the system.



**WARNING: The PCH Portal is used to control electrical and mechanical components of motion control systems in industrial environments. To avoid serious injury or damage to equipment, test the motion system for safety under all potential conditions.**

---

---



**WARNING: The PCH Portal is not intended for any use in systems, machines, or applications where failure or fault of the products could reasonably be seen to lead to death or serious bodily injury of any person, or to severe physical or environmental damage (“High-Risk Use”). You are not permitted to use, distribute, or sublicense the use of these products in High-Risk use applications. High-Risk use is STRICTLY PROHIBITED.**

---

---



**WARNING: The PCH Portal contains no user-serviceable parts. To avoid personal injury or damage to the product, do not attempt to open the case or to replace any internal component of the PCH Portal, Modules, or Accessories.**

---

---

**WARNING: USER RESPONSIBILITY- Improper use of the products described herein or related items can cause death, personal injury, and property damage.**

---

---



**CAUTION: Modification of endplate must always be done under the supervision of a Parker representative. If not, this may void any warranties.**

---

---

## 1.4 Important User Information

This document and other information from Parker Hannifin Corporation, its subsidiaries or authorized distributors provides product or system options for further investigation by users having technical expertise.

The user, through their own analysis and testing, is solely responsible for making the final selection of the system and components and assuring that all performance, endurance, maintenance, safety, and warning requirements of the application are met. The user must analyse all aspects of the application, follow applicable industry standards, and follow the information concerning the product in the current product catalog and in any other materials provided from Parker, its subsidiaries, or authorized distributors.

To the extent that Parker, its subsidiaries, or authorized distributors provide component or system options based upon data or specifications provided by the user, the user is responsible for determining that such data and specifications are suitable for all applications and reasonably foreseeable uses of the components or systems.

## 1.5 Intended Use

The PCH Portal must be used as follows:

- As intended for industrial environments and conditions as compliant with the regulatory agencies of the region.
- In the original state without unauthorized modifications to the unit. The only permissible configurations and/or modifications allowed are mentioned in the documentation supplied with the product.
- In perfect technical condition.
- The PCH Portal has been developed and manufactured in accordance with the basic and proven safety principles of EN ISO 13849, LVD 2014/35/EU (low voltage directive) and EN61000-6-2 (Electromagnetic compatibility) and European Machinery Directive 2006/42/EC. The requirements of EN ISO 13849-1 and EN ISO 13849-2 must be taken into consideration to implement and operate the PCH Portal. When using this product in machines or systems subject to specific C standards, the requirements specified in these standards must be observed.
- This product is not CSA Certified. To conform to CSA C22.2 requirements please ensure the PCH Portal is connected to a class 2 power supply or equal as outlined in CSA Article 2.024 for low voltage equipment. The output of this power supply may not exceed 100 VA, with the operating voltage not more than 30 V rms, 42.4 V peak, or 60 V dc.

If standard accessories/components are connected (e.g., sensors, actuators, etc.) the specified limits of pressure, temperature, electrical data, torques, etc. must be complied with.

Even though care has been taken in the preparation and publication of the contents of this manual, we do not assume legal or other liability for any inaccuracy, mistake, misstatement, or any other error of whatsoever nature contained herein. The material in this manual is for information purposes only and is subject to change without notice.

## 1.6 Service Information

Consult the local Parker Service Agent if you have any technical problems or queries.

## 1.7 Assumptions of Technical Experience

Parker Hannifin Corporation assumes qualified personnel are involved in the servicing of industrial control systems and trained in recognizing hazards in products with hazardous energy levels. To install and troubleshoot the PCH Portal, the personnel must have a fundamental understanding of the following:

- Electronic concepts such as voltage, current, and switches
- Knowledge on the mechanical aspects of mounting the PCH Portal in the machine tool environment.
- Good understanding of the Networking concepts and implementation of safety circuitry

## 1.8 Product Naming

This guide describes the following product:

- PCH Portal

---

---

**NOTE:** For ordering information/part number structure, refer to 8.5

---

---

## 1.9 Notes, Cautions and Warnings

This guide uses notes, cautions, and warnings throughout the text to draw attention to information that is especially important or useful.



**WARNING:** A warning provides information about a potential for property damage, personal injury, or death.

---

---



**CAUTION:** A caution provides information intended to help prevent improper use of the product or damage to the product hardware or software.

---

---

---

---

**NOTE:** A note provides information intended to make the best use of the product from Parker Hannifin Corporation.

---

---

## CHAPTER - 2 **Overview**

# Overview

## 2.1 Product Overview

The PCH Portal is a networked slave IO control device that supports multiple “Industrial Ethernet” communication protocols to communicate with other industrial controllers in the automation industry.

The PCH Portal is engineered to interface with a manifold containing up to 32 H ISO Universal valve channels as well as to offer a wide variety of discrete and IO-Link input/output arrangements for motion control, while withstanding the temperature ranges, vibrations, and electrical noise of industrial environments.



Figure 1 — PCH Portal

# Overview

## 2.2 Module Overview

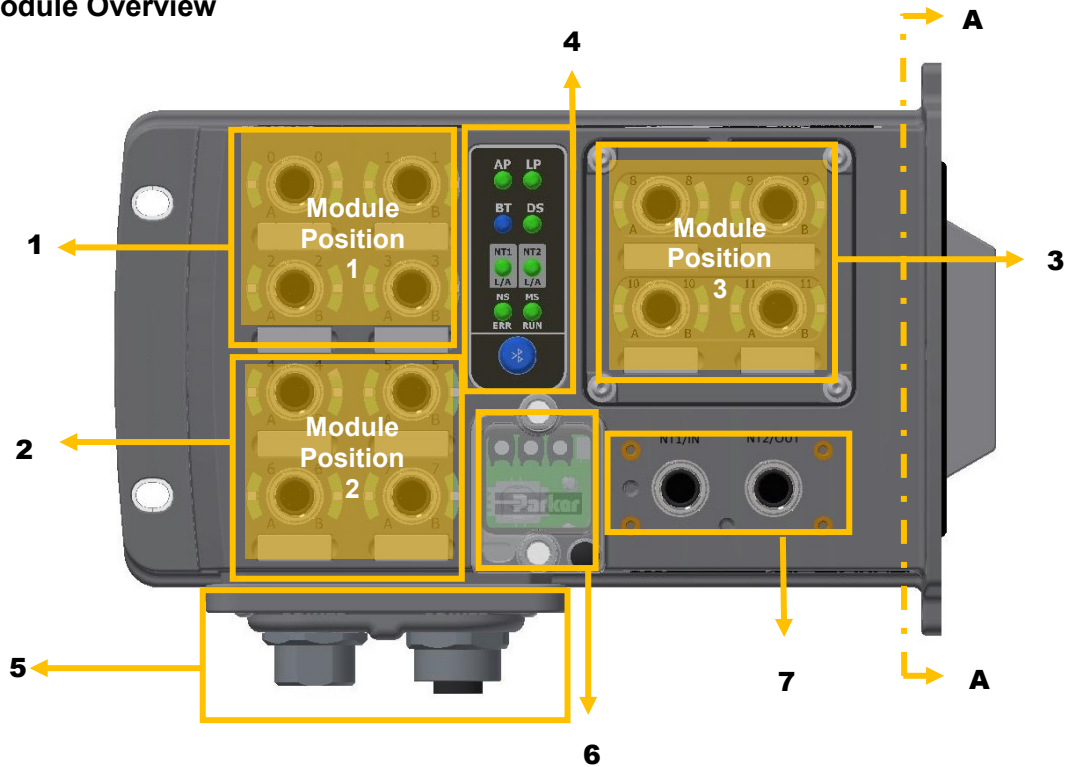

Figure 2 — Module Overview

Table 1 — Module Overview

Module Overview	
Item No	Part Name
1	Module Position 1*
2	Module Position 2*
3	Module Position 3**
4	Status LEDs/Bluetooth enable button
5	Power Supply Connectors
6	Rotary Switches, USB connector (Type B)
7	Network Communication Ports – NT1 and NT2
A	Connection to H Universal Air Supply

**NOTE:**

\* Possible options: “A” Module, “B” Module, “C” Module.

\*\* Possible options: “A” Module, “B” Module, “C” Module, Blank Plate.

# Overview

## 2.3 Power Supply Connectors

The Aux and Logic power connectors supply the power to all modules of the PCH Portal, the mother board, and other modules.

The following four types of power connectors are available based on the end user's requirement. Power consumption requirements must be considered when selecting a power connection. When using the power out connector to supply downstream power, the total power consumption available for downstream devices is equal to maximum capacity of connector pins ( $AUX_{PT} = 20A$  and  $LOG_{PT} = 20A$ ) less the current draw of PCH. The PCH internal limits are as follows:  $AUX_{PCH} = 12A$  and  $LOG_{PCH} = 8A$ . The PCH internal limits include devices connected to any of the 3 IO/IO-Link modules, and total wattage of the valve coils. Care must be taken in knowing the downstream current draw in order not to overload the maximum current rating of the pins. User can select 4-pin or 5-pin connectors configurations. Zone 1-3 is 24Vdc, 3.84A and Zone 4 is 24V, 1.28A.

**NOTE:** 5 pin connectors utilize pin 3 for protective earth ground.

**Table 1 — Types of Aux Power Connectors**

S. No.	Type of Aux Power Connectors	Connector Pin	Connector Configuration	Description
1	A and B	4 Pin	IN OUT	4 Pin - A - Power IN - Power OUT
2		5 Pin	IN OUT	5 Pin - B - Power IN - Power OUT
3	C and D	4 Pin	IN IN	4 Pin - C - Power IN - Power IN
4		5 Pin	IN IN	5 Pin - D - Power IN - Power IN

### Type 1: 4 Pin "A" (Power IN-Power OUT)

**Table 2 — 4 Pin-A- (Power IN-Power OUT)**

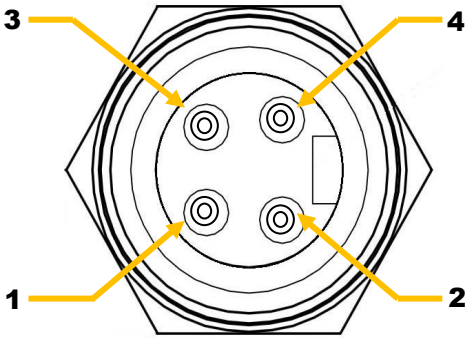
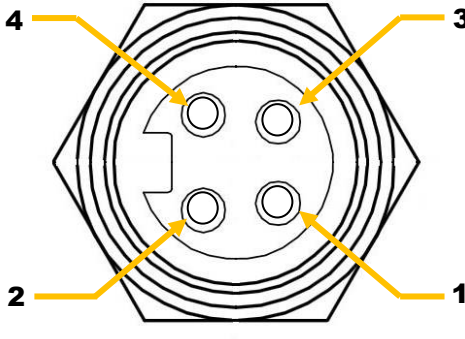
Power In (Male)			Power Out (Female)		
					
Pin	Function	Description	Pin	Function	Description
1	+24 V	+24V V2 (VAUX)	1	+24 V	+24V V2 (VAUX)
2	+24 V	+24V V1 (VLOG)	2	+24 V	+24V V1 (VLOG)
3	0 V	GND V1 (VLOG)	3	0 V	GND V1 (VLOG)
4	0 V	GND V2 (VAUX)	4	0 V	GND V2 (VAUX)

# Overview

## Type 2: 5 Pin- “B”- (Power IN-Power OUT)

Table 3 — 5 Pin- “B”- (Power IN-Power OUT)

Power In (Male)			Power Out (Female)		
Pin	Function	Description		Function	Description
1	0 V	GND V2 (VAUX)		0 V	GND V2 (VAUX)
2	0 V	GND V1 (VLOG)		0 V	GND V1 (VLOG)
3	Protective Earth	Protective Earth		Protective Earth	Protective Earth
4	+24 V	+24V V1 (VLOG)		+24 V	+24V V1 (VLOG)
5	+24 V	+24V V2 (VAUX),		+24 V	+24V V2 (VAUX)

## Type 3: 4 Pin- “C”- (Power IN-Power IN)

Table 4 — 4 Pin - “C” - (Power IN-Power IN)

Power In (Male)			Valve Power In (Male)		
Pin	Function	Description		Function	Description
1	+24V	+24V V2 (VAUX)		+24V	+24V V2 (VAUX) 1-3
2	+24V	+24V V1 (VLOG)		+24V	+24V V2 (VAUX) 4
3	0V	GND V1 (VLOG)		0V	Safe GND 1-3
4	0V	GND V2 (VAUX)		0V	Safe GND 4

# Overview

## Type 4: 5 Pin- "D"- (Power IN-Power IN)

Table 5 — 5 Pin - "D" - (Power IN-Power IN)

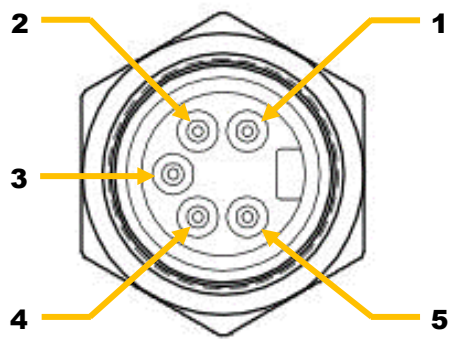
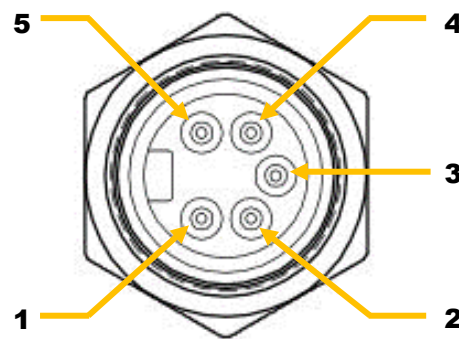
Power In (Male)			Valve Power In (Male)		
					
Pin	Function	Description		Function	Description
1	0V	GND V2 (VAUX)		+24V	+24V V2 (VAUX) 1-3
2	0V	GND V1 (VLOG)		+24V	+24V V2 (VAUX) 4
3	Protective Earth	Protective Earth		Protective Earth	Protective Earth
4	+24V	+24V V1 (VLOG)		0V	Safe GND 1-3
5	+24V	+24V V2 (VAUX)		0V	Safe GND 4

All four types of power connectors are capable of operating with SAFE pulsed power; however, it is recommended to use the 4 Pin C-type and 5 Pin D-type connector boards to connect SAFE 24Vdc auxiliary source in PP or PM mode for valve control, as the grounds are isolated. The connection diagram is as shown below:

# Overview

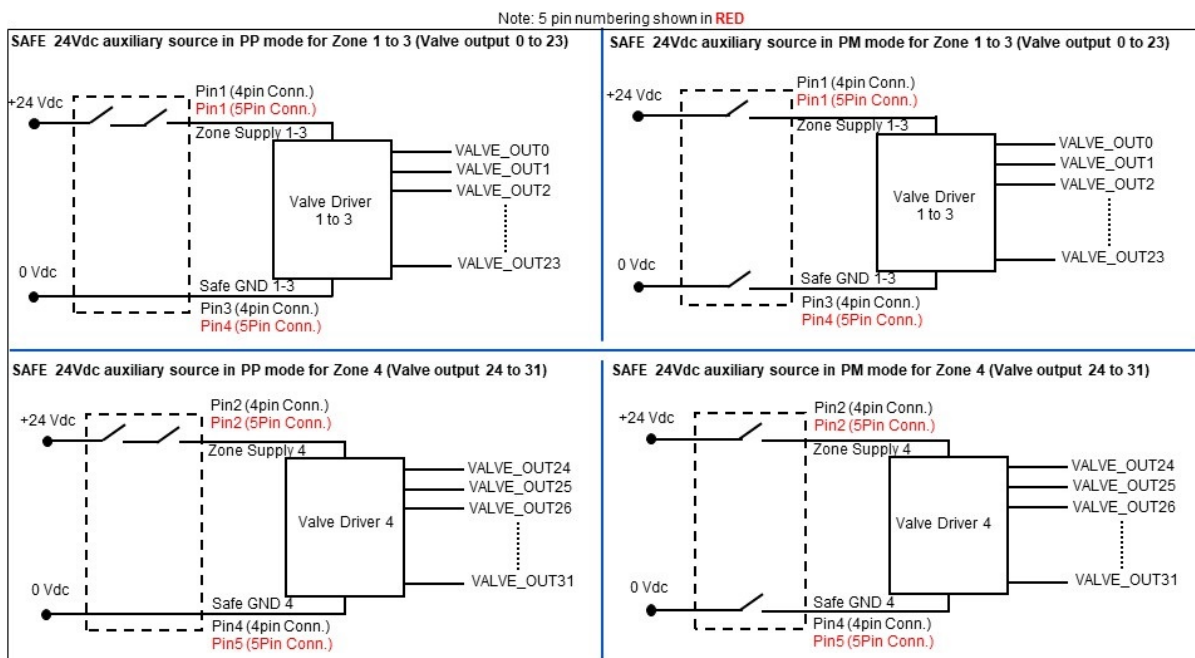

Figure 3 — C/D Board Wiring

**NOTE:** The power back-up functionality (storing of cycle counts and error/warning/event log) of PCH Portal is not guaranteed to function if the PCH Portal is operated outside operating voltage range i.e., when the logic voltage is  $\leq 20.4V$ .

If Aux voltage goes below the operating voltage range for the duration of 225 +/- 25 msec then the valve outputs and Aux voltage digital outputs are turned OFF for safety purpose. This behaviour is not applicable for A Module as outputs on this module operate on logic supply.

To avoid unwanted motion in field a hysteresis of 200 mV is maintained to turn ON/OFF outputs in case of Aux voltage error condition.

## 2.4 Grounding

The chassis ground is connected to the earth connection at the highlighted point below:



Figure 4 — Grounding Point

# Overview

## 2.5 I/O and IO-Link

- **“A” Module (IO-Link Class A or configurable I/O):** This module has 4 M12 ports and is powered by Logic Power. Each port has the following configurations:
  - i. 1 IO-Link class A master and pin 2 configurable as input or output  
OR
  - ii. 2 inputs, 24VDC (PNP or NPN)  
OR
  - iii. 2 outputs (Logic Power), 250mA @ 24VDC

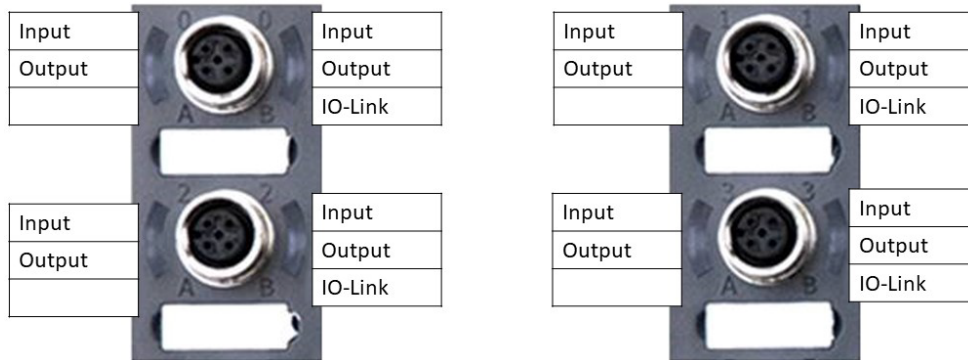

Figure 5 — A Module

Table 6 — A Module Port Details

Connector	Pin No.	Function
	1	+24V, 500mA VLOG (V1)
	2	Input (PNP or NPN)/Output +24V, 250 mA (V1)
	3	GND (V1)
	4	IO-Link/Input (PNP or NPN)/Output +24V, 250mA (V1)
	5	Not Connected

# Overview

- **“B” Module (IO-Link Class B or configurable I/O):** This module has 4 M12 ports. Each port has the following configurations:
  - IO-Link class B master  
OR
  - 1 input, 24VDC (PNP or NPN), PIN 4  
OR
  - 1 output (Logic Power), 250mA @ 24VDC, PIN 4

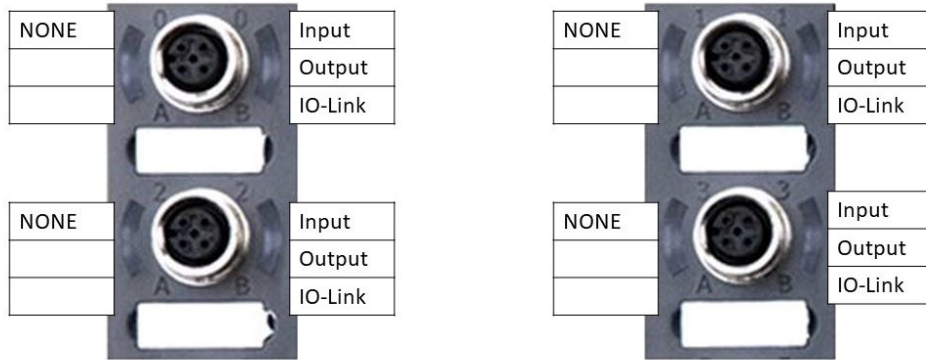

Figure 6 — B Module

Table 7 — B Module Port Details

Connector	Pin No.	Function
	1	+24V, 250mA VLOG (V1)
	2	+24V, 1.2A VAUX (V2)
	3	GND (V1)
	4	IO-Link/Input (PNP or NPN)/Output +24V, 250mA (V1)
	5	GND (V2)

# Overview

- **“C” Module (IO-Link Class B or configurable I/O with Aux Outputs):** This module has 4 M12 ports. Each port has the following configurations:
  - i. 2 M12 ports with Digital Output.
    - a. 2 outputs (Aux Power), 500mA @ 24VDC
  - ii. 2 M12 ports with each port having the following configuration:
    - a. 1 IO-Link class B master  
OR
    - b. 1 input, 24VDC (PNP or NPN), PIN 4  
OR
    - c. 1 output (Logic Power), 250mA @ 24VDC, PIN 4

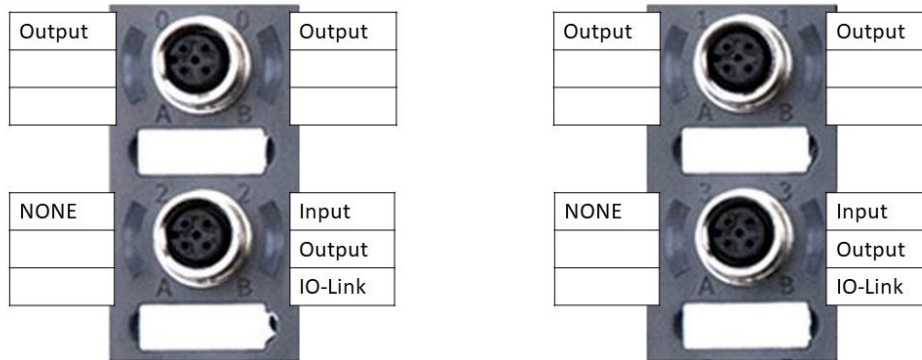

Figure 7 — C Module

Table 8 — “C” Module Aux Output Port Details (Port 0 and 1 of this Module)

Connector	Pin No.	Function
	1	Not Connected
	2	Output +24VAUX (V2), 500mA
	3	GND (V2)
	4	Output +24VAUX (V2), 500mA
	5	Not Connected

Table 9 — “C” Module IO-Link Class B Port Details (Port 2 and 3 of this Module)

Connector	Pin No.	Function
	1	+24V, 250mA VLOG (V1)
	2	+24V, 1.2A VAUX (V2)
	3	GND (V1)
	4	IO-Link/Input (PNP or NPN)/Output +24V, 250 mA (V1)
	5	GND (V2)

## 2.6 Status LEDs/Bluetooth Enable Button

**Status LEDs:** The LED's are used to indicate the status of Aux Power (AP), Logic Power (LP), Bluetooth Module Status (BT), Network Status (NS), Module Status (MS), Device Status (DS), Network Port 1 Link/Activity (NT1) and Network Port 2 Link/Activity (NT2).

**Bluetooth Enable Button:** Press and hold this button for more than 3 seconds to enable/disable the Bluetooth functionality. The Bluetooth communication is used to connect to PCH Portal via Bluetooth mobile application and PC Configuration Tool (refer to CHAPTER - 5). To connect using PC Configuration Tool over Bluetooth, a low energy Bluetooth (BLE) USB Dongle must be connected to a USB port of Windows PC.

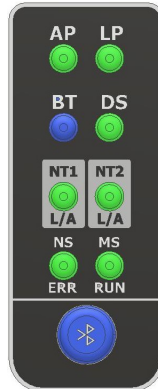

**Figure 8** — Status LEDs/Bluetooth Enable button

The following table gives the status indication of the Aux Power, Logic Power, Bluetooth, Device and Network ports.

**Table 10** — PCH Device LED Indication

LED Status Label	Indication	Description
Error LED or Network Status (NS)LED	OFF	No IP address or in state EXCEPTION
	Solid Green	At least one Modbus message received
	Flashing Green	Waiting for first Modbus message
	Solid Red	IP address conflict detected, FATAL ERROR
	Flashing Red	Connection timeout. No Modbus message has been received within the configured "process active timeout" time
Run LED or Module Status (MS)LED	OFF	No Power
	Solid Green	Normal operation
	Solid Red	Major fault in the PCH device
	Flashing Red	Minor fault in the PCH device
Link/Activity (L/A) LED for network port 1 and network port 2 (NT1, NT2)	OFF	No link, No activity
	Solid Green	100 Mbps link established
	Flashing Green	100 Mbps Network Activity
	Solid Yellow	10 Mbps link established
	Flashing Yellow	10 Mbps Network Activity

# Overview

LED Status Label	Indication	Description
Bluetooth (BT)	OFF	Bluetooth communication OFF
	Solid Blue	Bluetooth module is communicating with PC Utility over Bluetooth Interface
	Flashing Blue	Bluetooth module is not communicating with PC Utility over Bluetooth Interface or Bluetooth module firmware upgrade in progress
Auxiliary Power (AP)	Solid Red	Auxiliary Power below 19.40 V (Hysteresis 19.60V) or above 29.50V (Hysteresis 29.30V)
	Flashing Red	Auxiliary Power between 19.40V to 20.40V (Hysteresis 19.60V to 20.60V) or 28.80V to 29.50V (Hysteresis 28.60V to 29.30V)
	Solid Green	Auxiliary Power between 20.40 V to 28.80V (Hysteresis 20.60V to 28.60V)
	Solid Magenta	Auxiliary Current above 12 Amps
Logic Power (LP)	OFF	Logic Power below 16.00V or above 29.50V
	Solid Red	Logic Power between below 19.40V (Hysteresis 19.60V)
	Flashing Red	Logic Power between 19.40V to 20.40V (Hysteresis 19.60V to 20.60V) or above 28.80V (Hysteresis 28.60V)
	Solid Green	Logic Power between 20.40V to 28.80V (Hysteresis 20.60V to 28.60V)
	Flashing Magenta	Logic current between 7.5 Amps to 8 Amps
	Solid Magenta	Logic current above 8 Amps
Device Status (DS)	Solid Green	Valid product code
	Flashing Green	Invalid IP Address - Rotary Switch Out of Range
	Flashing Yellow	Invalid Configuration from PLC
	Flashing Red	Invalid product code/Valve short circuit
	Solid Red	Internal error
	Solid Yellow	Internal warning
	Flashing Magenta	Internal warning
	Solid Magenta	Internal Error on modules
	Flashing Cyan	Temperature between 75 ° C to 80 ° C/Reset to default in progress
	Solid Cyan	Temperature above 80 ° C
Solid Magenta	Module error	

# Overview

## 2.7 USB connector and Rotary Switches

**USB Connector:** The USB 2.0 OTG, Type-B standard connector is used to interface with the configuration software. The configuration software is used to configure and monitor the PCH Portal product.

**Rotary Switches:** The PCH Portal contains 3 rotary switches. These are used to set the last octet of the IP Address (assigning a static IP address), factory default, Enable FTP and DHCP mode.

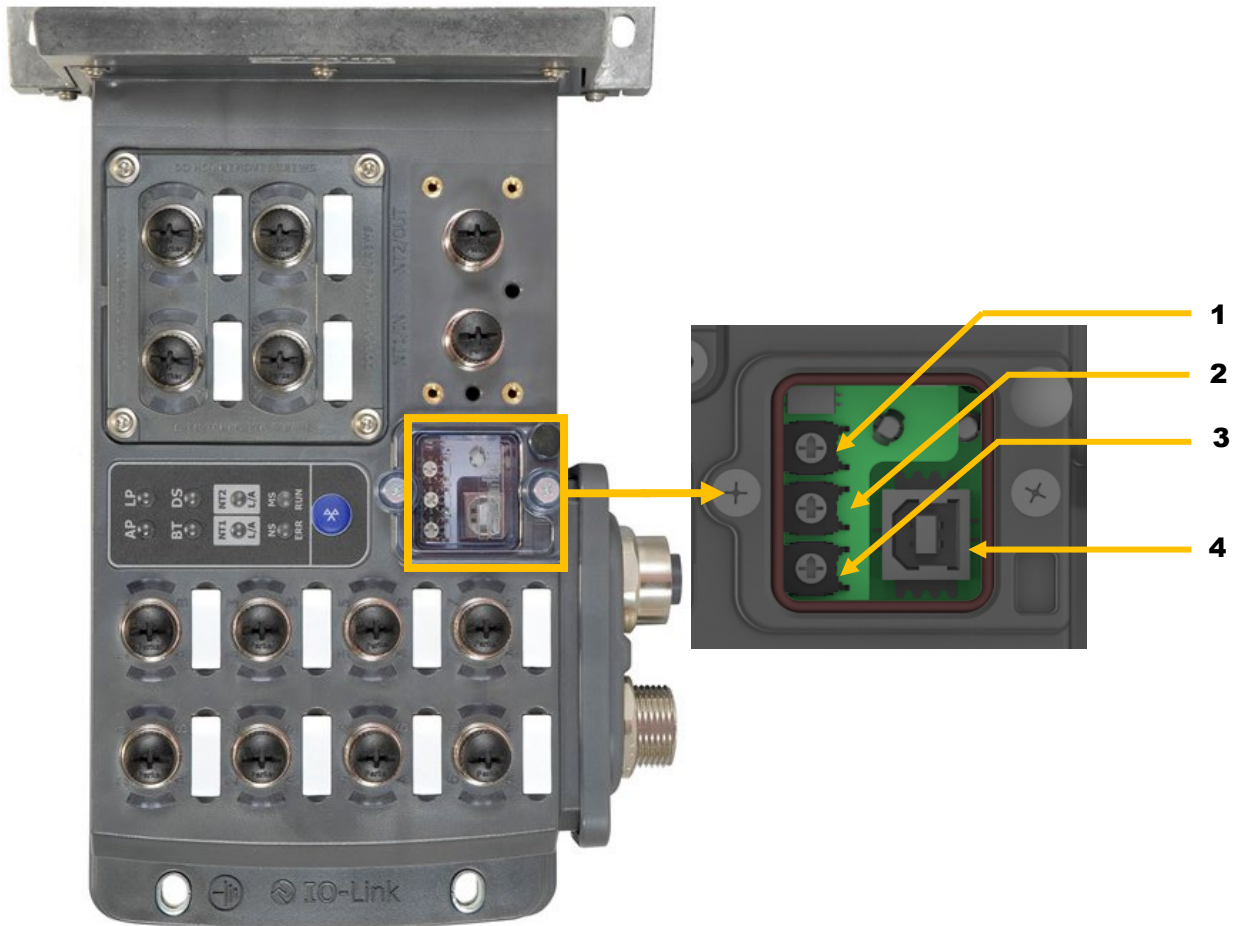

Figure 9 — USB Port and Rotary Switch Details

Table 11 — USB Port and Rotary Switch Details

Callout No.	Details
1	Rotary Switch x1
2	Rotary Switch x10
3	Rotary Switch x100
4	USB Port

# Overview

The Rotary switches are housed besides the USB port. The rotary switches are used to configure the PCH Portal product for the following functionalities based on the rotary switch settings shown in Table 13.

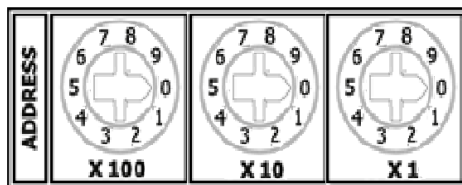

**Figure 10** — Rotary Switch Configuration Details

**Table 12** — Rotary Switch Configuration Details

Rotary Switch Setting	Description
001 – 254	A setting of 001 to 254 on rotary switch and power cycle of PCH Portal enables PCH device to use static IP address. The last octet of the IP address is as per the rotary switch setting, and the first three octets are as configured in config utility over USB and web interface. (Factory Default: IP: 192.168.1.8)
333	A setting of 333 on the rotary switch and power cycle of the PCH Portal allows config utility over USB and web interface to configure all four octets of IP address of the PCH Portal. After IP address configuration through utility, power cycle of PCH Portal once again results in PCH Portal to boot-up with IP address configured using the config tool.
387	Enable FTP
888	A setting of 888 on the rotary switch and power cycle of the PCH Portal configures PCH Portal to use IP address assigned by DHCP server.
999	A setting of 999 on the rotary switch and power cycling the PCH Portal resets all the configuration data to the factory default IP: 192.168.1.8.
Out of range	Status LED blinking GREEN, indicating IP address out of range. The last good IP address is the IP address used by the PCH Portal before last reset.

**NOTE:** A setting on rotary switch other than 001 to 254, 333, 387, 575 and 999 results in the PCH Portal boot-up with last good IP address and the Device Status LED blinking GREEN, which indicates IP address out of range. The last good IP address is the IP address used by the PCH Portal before last reset.

# Overview

## 2.8 Network Communication Ports NT1 and NT2

The Network Communication Ports are used to connect the PCH Portal to external devices in the automation system.

Table 13 — Network Interface

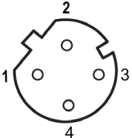
M12, D-coded, female	Pin No.	Function
	1	Tx+
	2	Rx+
	3	Tx-
	4	Rx-

## 2.9 Connection to H Universal Air Supply

There are 2 connectors (30 pin and 10 pin) for up to 32 valves. 24 valves can be connected to 30 pin connectors and 8 valves can be connected to 10-pin connector. Each valve output has a maximum of 160 mA at 24 V.

### Valve Output Pinout:

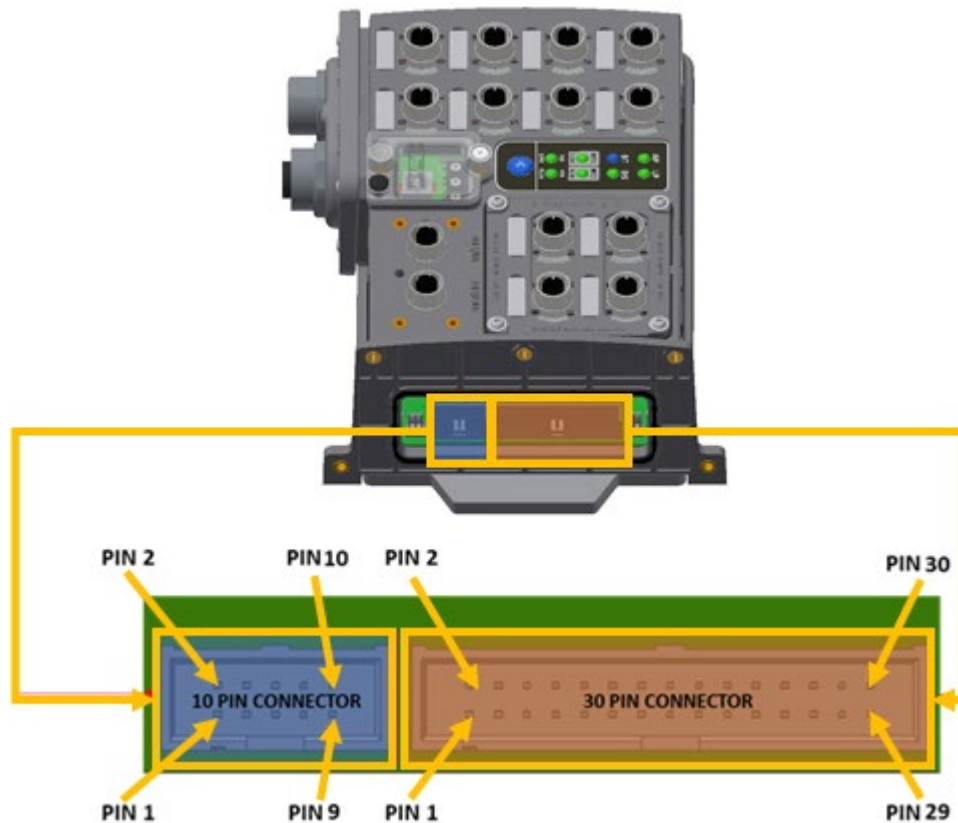
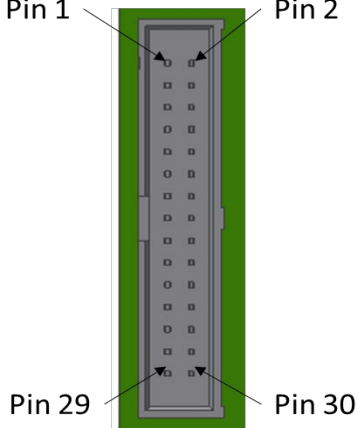
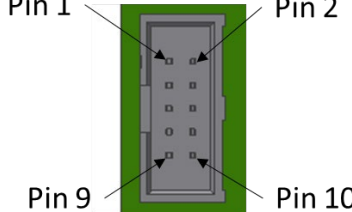

Figure 11 — Valve Output Pinout

**Table 14 — Valve Output Pinout Details**

Connector	Pin Number	Function
 <p>The diagram shows a vertical 30-pin connector. The pins are arranged in a single column. Labels with arrows point to Pin 1 (top), Pin 2 (second from top), Pin 29 (second from bottom), and Pin 30 (bottom).</p>	1	GND V2/Safe GND 1
	2	GND V2/Safe GND 1
	3	GND V2/Safe GND 1
	4	GND V2/Safe GND 1
	5	GND V2/Safe GND 1
	6	Protective Earth
	7	VALVE_OUT0
	8	VALVE_OUT1
	9	VALVE_OUT2
	10	VALVE_OUT3
	11	VALVE_OUT4
	12	VALVE_OUT5
	13	VALVE_OUT6
	14	VALVE_OUT7
	15	VALVE_OUT8
	16	VALVE_OUT9
	17	VALVE_OUT10
	18	VALVE_OUT11
	19	VALVE_OUT12
	20	VALVE_OUT13
	21	VALVE_OUT14
	22	VALVE_OUT15
	23	VALVE_OUT16
	24	VALVE_OUT17
	25	VALVE_OUT18
	26	VALVE_OUT19
	27	VALVE_OUT20
	28	VALVE_OUT21
	29	VALVE_OUT22
	30	VALVE_OUT23

**Table 15** — Valve Output Pinout Details

Connector	Pin Number	Function
	1	GND V2/Safe GND 2
	2	GND V2/Safe GND 2
	3	VALVE_OUT24
	4	VALVE_OUT25
	5	VALVE_OUT26
	6	VALVE_OUT27
	7	VALVE_OUT28
	8	VALVE_OUT29
	9	VALVE_OUT30
	10	VALVE_OUT31

**NOTE:** The valve outputs operate on Aux voltage and have latching behavior. In case the logic voltage drops below operating range ( $< 16\text{ V}$  or  $> 30\text{V}$ ), the valve outputs remain latched to the state they were set to when the PCH Portal logic supply was in operating range.



**CAUTION:** To comply with the protection class IP65, seal the unused ports with the appropriate plugs or cover caps.

# Overview

- The PCH Network Portal can use the following H ISO Universal Valves:
  - ISO 15407-2 – sizes 02 & 01
  - ISO 5599-2 – sizes 1, 2 & 3
- The PCH Network Portal can support up to 32 addresses as shown
- The data map and PCH Tool refers to each address with a Valve\_X designator. Each Valve\_X designator is as shown.
- Addresses 25-31 can be accessed using an Intermediate Air Supply with Electric Expansion
- Each address is one solenoid

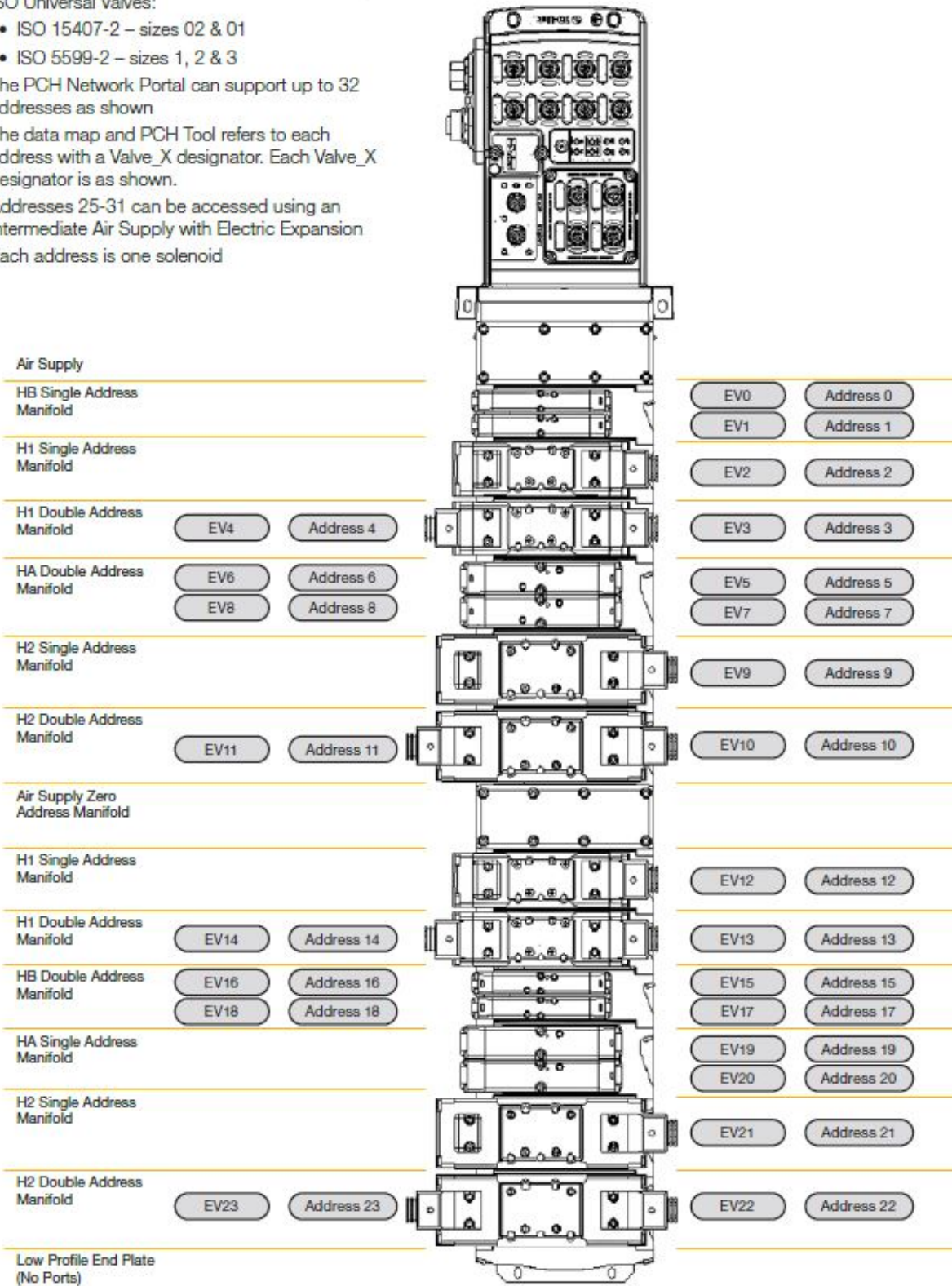

Figure 12 — Solenoid Addressing

# Overview

## 2.10 Port and Port LED Descriptions

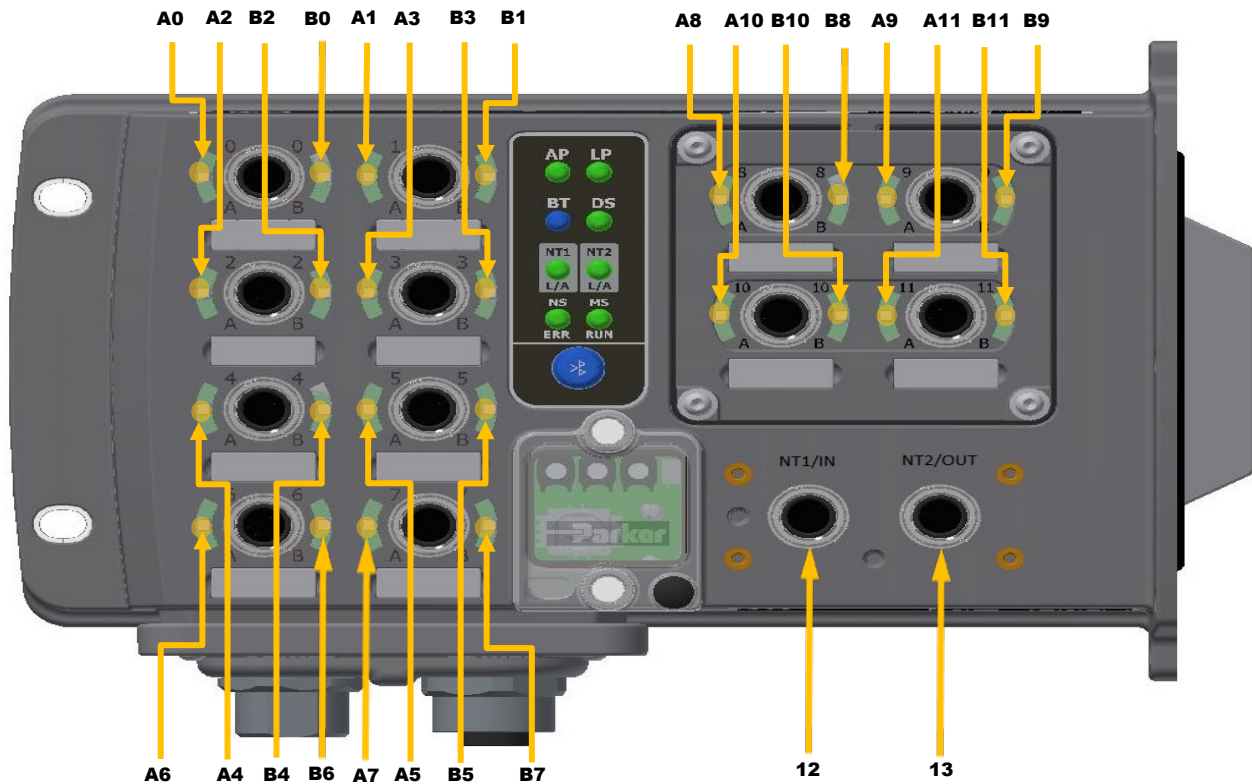

Figure 13 — Port Description

Table 16 — Port Description

Port Description		Port Description	
Callout No.	Port Number	Callout No.	Port Number
A0 (Channel 0)	Port 0/A (Pin 2)	B6 (Channel 13)	Port 6/B (Pin 4)
B0 (Channel 1)	Port 0/B (Pin 4)	A7 (Channel 14)	Port 7/A (Pin 2)
A1 (Channel 2)	Port 1/A (Pin 2)	B7 (Channel 15)	Port 7/B (Pin 4)
B1 (Channel 3)	Port 1/B (Pin 4)	A8 (Channel 16)	Port 8/A (Pin 2)
A2 (Channel 4)	Port 2/A (Pin 2)	B8 (Channel 17)	Port 8/B (Pin 4)
B2 (Channel 5)	Port 2/B (Pin 4)	A9 (Channel 18)	Port 9/A (Pin 2)
A3 (Channel 6)	Port 3/A (Pin 2)	B9 (Channel 19)	Port 9/B (Pin 4)
B3 (Channel 7)	Port 3/B (Pin 4)	A10 (Channel 20)	Port 10/A (Pin 2)
A4 (Channel 8)	Port 4/A (Pin 2)	B10 (Channel 21)	Port 10/B (Pin 4)
B4 (Channel 9)	Port 4/B (Pin 4)	A11 (Channel 22)	Port 11/A (Pin 2)
A5 (Channel 10)	Port 5/A (Pin 2)	B11 (Channel 23)	Port 11/B (Pin 4)
B5 (Channel 11)	Port 5/B (Pin 4)	12	Ethernet Port 1 (NT1)
A6 (Channel 12)	Port 6/A (Pin 2)	13	Ethernet Port 2 (NT2)

# Overview

## 2.11 IO Port LED Indication

Each of the Ports have two LEDs to indicate the I/O-States that are configured.

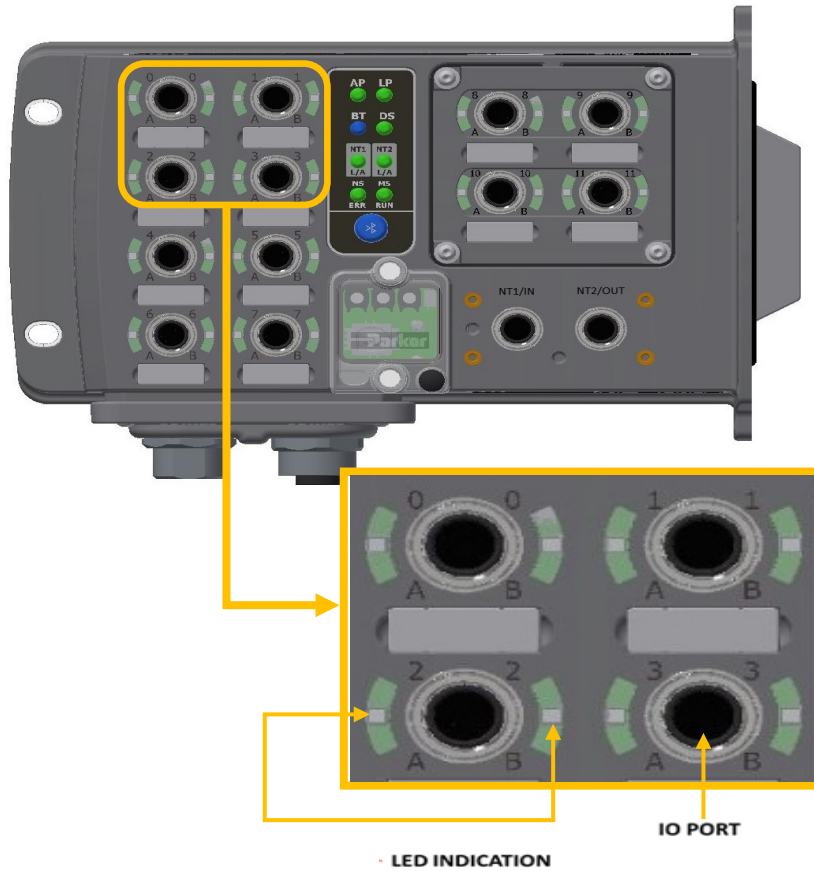

Figure 14 — IO-Port LED

Table 17 — IO Port LED Indication

Color Indication	Status
OFF	Input is configured and input is OFF
Light Blue	Output is configured and output is OFF (Type A module) OR I/O is not configurable (Type B module)
Yellow	Input is ON or Output is actuated
Yellow flashing	During firmware upgrade
Red	Over current at I/O or IO-Link point
Red flashing	Short-circuit at supply/Validation Error/Data Storage Error
Green	IO-Link Configured, and IO-Link slave connected
Green rapid flashing	IO-Link port is getting configured
Green flashing	IO-Link Configured, and IO-Link slave not connected
Magenta	The application image present in flash is not valid
Magenta flashing	Watchdog error

CHAPTER - 3 **Technical Data**



# Technical Data

## 3.1 Dimensions

Footprint dimensions: length, width, height of entire PCH

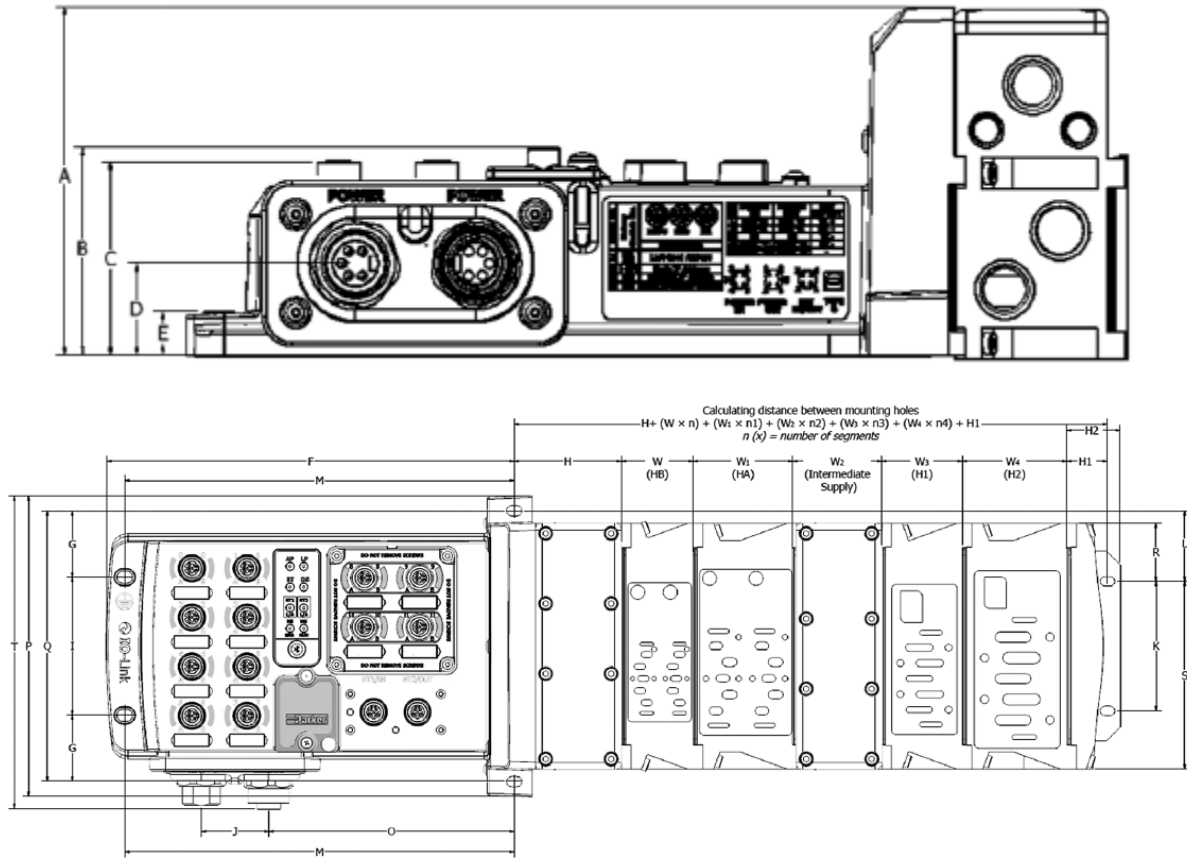

n (x) = number of segments

A	B	C	D	E	F	G	H	H1	H2	J	K	L
4.42	2.64	2.46	1.17	.55	9.32	1.51	2.36	.9	1.22	1.55	2.95	1.6
(112.3)	(67.1)	(62.5)	(29.7)	(14)	(236.7)	(38.4)	(59.9)	(22.9)	(31)	(39.4)	(74.9)	(40.6)
M	O	P	Q	R	S	T	W	W1	W2	W3	W4	
8.91	5.61	6.86	6.18	1.33	4.28	7.14	1.63	2.28	2.03	1.82	2.39	
(226.3)	(142.5)	(174.2)	(157)	(33.8)	(108.7)	(181.4)	(41.4)	(57.9)	(51.6)	(46.2)	(60.7)	

Inches (mm)

Mounting holes dimensions

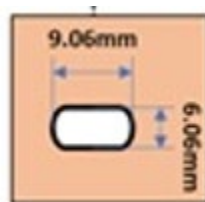

Figure 15 — Physical Dimensions

# Technical Data

## 3.2 Mechanical Data

**Table 18 — Mechanical Data**

Parameters	Details
Housing material	Housing /Enclosure: PBT with 33% GF and UL94-V0 Base Cover (plate): Aluminum 380
Enclosure rating	IP 65 (only when plugged-in and threaded-in)
Supply Voltage	7/8" 4 or 5 pin male and female pin connector or AIDA
Input ports/ Output ports	M12, A-coded (12 x female)
Dimensions (L x B x H in mm)	226.6mm x 130.7mm x 55mm
Mounting type	Screw Mount
Ground strap attachment	M5
Weight	Approx. 1.3 kg

## 3.3 Operating Conditions

**Table 19 — Operating Conditions**

Parameters	Details
Operating Temperature	0°C to 50°C
Storage Temperature	-25°C to 70°C
Industrial Immunity	IEC 61000-6-2
Industrial Emission	IEC 61000-6-4
Shock/Vibrations	IEC 60068-2-27:2008
	IEC 60068-2-6:2007
Electrostatic Discharge	IEC 61000-4-2
Electrical Fast Transient/ Burst	IEC 61000-4-4
Surge Immunity	IEC 61000-4-5

## 3.4 Electrical Data

**Table 20 — Electrical Data**

S. No.	Topic	Details
1	Supply Voltage	24VDC (-15% to +20%)
2	Logic current at 24 V (V1)	Max Current 8A – Actual usage depends on configuration.
3	Auxiliary current at 24 V (V2)	Max Current 12A – Actual usage depends on configuration.
4	Input current at 24V (Zone 1-3)	Max Current 3.84A – Actual usage depends on configuration.
5	Input current at 24V (Zone 4)	Max Current 1.28A – Actual usage depends on configuration

## CHAPTER - 4 **PCH Portal Function**

# PCH Portal Function

## 4.1 Modbus-TCP Functions

PCH Portal supports Modbus function codes listed in the Table 22, for accessing the process input data, process output data, configuration parameters, diagnostics, and device information. Exception codes supported are given in Table 23.

**Table 21 — Supported Function Codes**

Function Code	Function	Description
1	Read Coils	Read Single/Multiple Discrete Outputs Ex: Process Data – Valves, DO
2	Read Discrete Inputs	Read Single/Multiple Discrete Inputs Ex: Process Data – Standard Inputs, Status Bytes
3	Read Holding Registers	Read Single/Multiple Registers Ex: Configuration Data, Output Process Data (DO, IO-Link), Acyclic Data
4	Read Input Registers	Read Single/Multiple Input Ex: Process Data – DI, IO-Link Process Input Data and Status, Status Bytes
5	Write Single Coil	Write Single Discrete Output Ex: Actuate Valve, DO
6	Write Single Register	Write Single Holding Register Ex: Actuate Valves, DO, IO-Link Data
15	Write Multiple Coils	Write Multiple Discrete Outputs at a time Ex: Actuate Valves, DO
16	Write Multiple Registers	Write Multiple Holding Registers Ex: Configuration Data, Process Data (DO, IO-Link), Acyclic Data
23	Read/Write Multiple Registers	Write, and Read Multiple Holding Registers Ex: Configuration Data, Process Data (DO, IO-Link), Acyclic Data
43 (Sub Code 14)	Read Device Identification	Read the device identification Details.

**Table 22 — Exception Codes**

Code	Name	Description
0x01	Illegal function	The function code in the query is not supported
0x02	Illegal data address	The data address received in the query is outside valid address range
0x03	Illegal data value	The data in the request is illegal

# PCH Portal Function

## 4.2 Modbus Data Registers Mapping

The process data, configuration parameter data, diagnostic data are mapped to Modbus registers as given in the following table:

**Table 23 — Modbus Data Registers Mapping**

Modbus Registers Access Method	Description	Modbus Address Range (Decimal)
Discrete Inputs (1x) (Read Only): Bitwise access	Device Control Status (see Appendix A for more details)	0001 to 0064
	Standard Discrete Input Data (see Appendix A for more details)	0673 to 0696
Input Registers (3x) (Read Only): 16bit Register wise access	Device Status	0001 to 0006
	IO-Link Status Data	0007 to 0042
	Standard Discrete Input Data	0043 to 0044
	IO-Link Port Input Data	0045 to 0236
	Diagnostics Data	2049 to 2055
Coils (0x) (Read/Write): Bitwise access	Discrete Output Channel Data (see Appendix B for more details)	0001 to 0024
	Device Control (see Appendix B for more details)	0025 to 0032
	Valve Output Data (see Appendix B for more details)	0033 to 0064
Holding Registers (4x) (Read /Write): 16bit Register wise access	Discrete Output Channel Data/Device Control	0001 to 0002
	Valve Output Data	0003 to 0004
	IO-Link Port Output Data	0005 to 0196
	Configuration Data	4241 to 4496
	Acyclic Communication Registers	4497 to 5169

When a row of data in a table represents a byte instead of a word as shown in Table 25, location of byte in word is as per Table 26.

**Table 24 — Example for row representing a byte.**

Byte No	Register Address
Byte 1	1
Byte 2	
Byte 3	2
Byte 4	

**Table 25 — Location of byte in word**

Word		Register Address
Upper Byte	Lower Byte	
Byte 2	Byte 1	1
Byte 4	Byte 3	2

**Note:** Addresses in Modbus Messages are referenced starting from 0. Function Code field specifies which register group it operates on. For Example, holding register 40001 is addressed as register 0000 in Modbus Message.

# PCH Portal Function

## 4.3 Configuration Data

The Configuration Data registers can be accessed (Read/Write) as multiple registers (each register has 16-bit information).

1. Configuration Data can be accessed using the function code as follow:
  - a) Function Code 03: To Read the single or multiple registers.
  - b) Function Code 06: To Write single register.
  - c) Function Code 16: To Write multiple registers.
  - d) Function Code 23: To Write and read multiple registers.
2. All the address for the registers specified in the table are absolute addresses.
3. Master/PLC adds the offset to the base address while accessing (Read or Write) the registers.  
 Example: If the 5-digit addressing is used by master/PLC and base address of Holding Register is decimal 40001, then Configuration for I/O/IO-Link Port address is decimal 44240 to 44251.
4. The values written to reserved bytes is ignored.

The following tables give the information on the mapping of configuration data from the PLC.

### 4.3.1 Process Active Timeout

**Table 26 — Process Active Timeout**

Parameter	Offset		Word Count
	Dec	Hex	
Process Active Timeout (in ms)	4099	0x1003	1

Process Active Timeout defines how long PCH Portal stays connected to master after receiving a request. Default value is 0 ms. If this value is 0, “PLC Mode” radio button on Config Utility remains selected even after disconnecting master.

### 4.3.2 Parametrization

**Table 27 — Parametrization**

Bit 7	Bit 6	Bit 5	Bit 4	Bit 3	Bit 2	Bit 1	Bit 0	Offset		Word Count
								Dec	Hex	
Module Parametrization								4960	0x1360	1
RESERVED										

#### Module Parameterization

Enable = 1  
 Disable = 0

#### **NOTE:**

1. When module parameterization is enabled PCH will accept configuration from Engineering tool or PLC.
2. Irrespective of module parametrization (Enable/Disable) PCH will accept configuration from Web interface or Configuration tool.

# PCH Portal Function

## 4.3.3 Port Configuration

**Table 28 — Port Configuration**

Bit 7	Bit 6	Bit 5	Bit 4	Bit 3	Bit 2	Bit 1	Bit 0	Offset		Word Count
								Dec	Hex	
Port 0/A								4240	0x1090	12
Port 0/B										
Port 1/A								4241	0x1091	
Port 1/B										
Port 2/A								4242	0x1092	
Port 2/B										
Port 3/A								4243	0x1093	
Port 3/B										
Port 4/A								4244	0x1094	
Port 4/B										
Port 5/A								4245	0x095	
Port 5/B										
Port 6/A								4246	0x1096	
Port 6/B										
Port 7/A								4247	0x1097	
Port 7/B										
Port 8/A								4248	0x1098	
Port 8/B										
Port 9/A								4249	0x1099	
Port 9/B										
Port 10/A								4250	0x109A	
Port 10/B										
Port 11/A								4251	0x109B	
Port 11/B										

Possible values used to configure ports is given in Table 30.

**Table 29 — Pin Config**

Port Type	Value
Digital Input PNP	0
Digital Input NPN	4
Digital Output	1
IO-Link	2
None	3 or (Any value)

**NOTE:** To configure the I/O/IO-Link Ports, write/send all 12-registers data starting from offset 4240 (decimal).

# PCH Portal Function

## 4.3.4 Configuration of DI and DO Control Parameter

**Table 30 — DI/DO Configuration**

Field	Bit 7	Bit 6	Bit 5	Bit 4	Bit 3	Bit 2	Bit 1	Bit 0	Offset		Word Count
									Dec	Hex	
DO Fault Mode	P3B	P3A	P2B	P2A	P1B	P1A	P0B	P0A	4256	0x10A0	8
	P7B	P7A	P6B	P6A	P5B	P5A	P4B	P4A			
	P11B	P11A	P10B	P10A	P9B	P9A	P8B	P8A	4257	0x10A1	
	RESV	RESV	RESV	RESV	RESV	RESV	RESV	RESV			
DIO Counter Control	P3B	P3A	P2B	P2A	P1B	P1A	P0B	P0A	4258	0x10A2	
	P7B	P7A	P6B	P6A	P5B	P5A	P4B	P4A			
	P11B	P11A	P10B	P10A	P9B	P9A	P8B	P8A	4259	0x10A3	
	RESV	RESV	RESV	RESV	RESV	RESV	RESV	RESV			
DIO Counter Type	P3B	P3A	P2B	P2A	P1B	P1A	P0B	P0A	4260	0x10A4	
	P7B	P7A	P6B	P6A	P5B	P5A	P4B	P4A			
	P11B	P11A	P10B	P10A	P9B	P9A	P8B	P8A	4261	0x10A5	
	RESV	RESV	RESV	RESV	RESV	RESV	RESV	RESV			
DI Inversion	P3B	P3A	P2B	P2A	P1B	P1A	P0B	P0A	4262	0x10A6	
	P7B	P7A	P6B	P6A	P5B	P5A	P4B	P4A			
	P11B	P11A	P10B	P10A	P9B	P9A	P8B	P8A	4263	0x10A7	
	RESV	RESV	RESV	RESV	RESV	RESV	RESV	RESV			
Debounce Time	Port 0/A								4272	0x10B0	12
	Port 0/B										
	Port 1/A								4273	0x10B1	
	Port 1/B										
	Port 2/A								4274	0x10B2	
	Port 2/B										
	Port 3/A								4275	0x10B3	
	Port 3/B										
	Port 4/A								4276	0x10B4	
	Port 4/B										
	Port 5/A								4277	0x10B5	
	Port 5/B										
	Port 6/A								4278	0x10B6	
	Port 6/B										
	Port 7/A								4279	0x10B7	
	Port 7/B										
Port 8/A								4280	0x10B8		

# PCH Portal Function

Field	Bit 7	Bit 6	Bit 5	Bit 4	Bit 3	Bit 2	Bit 1	Bit 0	Offset		Word Count
									Dec	Hex	
Debounce Time	Port 8/B										
	Port 9/A								4281	0x10B9	
	Port 9/B										
	Port 10/A								4282	0x10BA	
	Port 10/B										
	Port 11/A								4283	0x10BB	
Port 11/B											

## 4.3.4.1 DO Fault Mode

This parameter defines the status of output in case of communication fault with PLC or backplane communication fault.

**Last Good (1):** Output is maintained in last known good state in case of communication fault.

**OFF (0):** Output is turned off in case of communication fault.

## 4.3.4.2 DIO Counter Control

This parameter enables or disables the cycle count limit notification functionality of digital input. If this parameter is enabled, then the PCH device raises the cycle limit reached warning when the cycle count limit is reached. The cycle count limit is configured through configuration tool.

**Enable (1):** Warning mode enabled.

**Disable (0):** Warning mode disabled.

## 4.3.4.3 DIO Counter Type

This parameter defines the behaviour of cycle count parameter of the digital IO as an up counter or down counter. This parameter has following two values.

**Up counter (0):** The cycle count associated with digital IO is incremented by one for every cycle of digital IO. The cycle count continues to increment beyond the configured cycle limit value (up to max limit of 20,000,000) in case cycle count type is configured as up counter.

**Down counter (1):** The cycle count associated with digital IO decrements by one for every cycle of digital IO. The cycle count does not decrement beyond zero after the respective IO is operated more than the configured maximum cycles in case the cycle type is configured as down counter.

The transition of digital IO from OFF to ON to OFF is counted as one cycle.

## 4.3.4.4 DI Inversion

This parameter enables or disables the inversion on digital input. If this parameter is enabled, then inverted status of respective input is communicated to PLC. The invert functionality is not applicable to LED indication on the PCH Portal. This parameter has two values:

**Enable (1):** Enables the inversion mode in the PCH Portal.

**Disable (0):** Disables the inversion mode in the PCH Portal.

---

**NOTE:** To configure DO fault mode, DIO counter control, DIO counter type and DI inversion, user need to write into all 8 registers starting from offset 4256 (0x10A0).

---

# PCH Portal Function

## 4.3.4.5 De-Bounce Time

This parameter defines the de-bounce time to ignore jitter in the input signal. This parameter applies for both ON to OFF and OFF to ON transition. If the de-bounce time configured is 0, then it disables the de-bounce logic. The valid range of this parameter is 0 to 120ms.

**NOTE:** To Configure de-bounce time parameter, user need to write into all 12 registers starting from offset 4272 (0x10B0).

## 4.3.5 Configuration of Valve Parameters

**Table 31 — Valve Configuration**

Field	Bit 7	Bit 6	Bit 5	Bit 4	Bit 3	Bit 2	Bit 1	Bit 0	Offset		Word Count
									Dec	Hex	
Valve Fault Mode	V07	V06	V05	V04	V03	V02	V01	V00	4288	0x10C0	6
	V15	V14	V13	V12	V11	V10	V09	V08			
	V23	V22	V21	V20	V19	V18	V17	V16	4289	0x10C1	
	V31	V30	V29	V28	V27	V26	V25	V24			
Valve Counter Control	V07	V06	V05	V04	V03	V02	V01	V00	4290	0x10C2	
	V15	V14	V13	V12	V11	V10	V09	V08			
	V23	V22	V21	V20	V19	V18	V17	V16	4291	0x10C3	
	V31	V30	V29	V28	V27	V26	V25	V24			
Valve Counter Type	V07	V06	V05	V04	V03	V02	V01	V00	4292	0x10C4	
	V15	V14	V13	V12	V11	V10	V09	V08			
	V23	V22	V21	V20	V19	V18	V17	V16	4293	0x10C5	
	V31	V30	V29	V28	V27	V26	V25	V24			

### 4.3.5.1 Valve Fault Mode

The Fault Value settings describes the behaviour of the valve outputs in case of communication fault with PLC or backplane communication fault. This has following two values:

**Last Good (1):** The valves are set to last good value after the communication error is detected.

**Off (0):** The valve is set to OFF state after the communication error is detected.

### 4.3.5.2 Valve Counter Control

This parameter enables or disables the cycle count limit notification functionality of valve output. If this parameter is enabled, then the PCH device raises the cycle limit reached warning when the cycle count limit is reached. The cycle count limit is configured through configuration tool. This has following two values:

**Enable (1):** Warning mode enabled.

**Disable (0):** Warning mode disabled.

# PCH Portal Function

## 4.3.5.3 Valve Counter Type

This parameter defines the behaviour of cycle count parameter of the valve output as an up counter or down counter. This parameter has the following two values:

**Up counter (0):** The cycle associated with valve increments by one, for every cycle of valve output. The cycle count continues to increment beyond the configured cycle limit valve (up to max limit of 20,000,000) in case cycle count type is configured as up counter.

**Down counter (1):** The cycle count associated with valve decrements by one for every cycle of valve output. The cycle count does not decrement beyond zero after the respective valve is operated for more than the configured maximum cycles in case the cycle count type is configured as down counter. The transition of valve output from OFF to ON to OFF is counted as one cycle.

**NOTE:** To configure Valve parameters, user need to write into 6 registers starting from offset 4288 (0x10C0).

## 4.3.6 Configuration of IO-Link Port Parameters

Table 32 — IO-Link Configuration

Port No	Bit 7	Bit 6	Bit 5	Bit 4	Bit 3	Bit 2	Bit 1	Bit 0	Offset		Word Count
									Dec	Hex	
Port 0	Data Storage								4304	0x10D0	13
	RESV										
	Validation Type								4305	0x10D1	
	RESV										
	Vendor ID Byte 1 (Higher Byte)								4306	0x10D2	
	Vendor ID Byte 2 (Lower Byte)										
	Device ID Byte 1 (Higher Byte)								4307	0x0D3	
	Device ID Byte 2										
	Device ID Byte 3 (Lower Byte)								4308	0x0D4	
	Base		Multiplier								
	Serial No. Byte 1 (Lower Byte)								4309	0x0D5	
	Serial No. Byte 2										
	Serial No. Byte 3								4310	0x0D6	
	Serial No. Byte 4										
	Serial No. Byte 5								4311	0x10D7	
	Serial No. Byte 6										
	Serial No. Byte 7								4312	0x10D8	
	Serial No. Byte 8										
	Serial No. Byte 9								4313	0x10D9	
	Serial No. Byte 10										
Serial No. Byte 11								4314	0x10DA		
Serial No. Byte 12											
Serial No. Byte 13								4315	0x10DB		
Serial No. Byte 14											

# PCH Portal Function

Port No	Bit 7	Bit 6	Bit 5	Bit 4	Bit 3	Bit 2	Bit 1	Bit 0	Offset		Word Count
									Dec	Hex	
Port 0	Serial No. Byte 15								4316	0x10DC	
	Serial No. Byte 16 (Lower Byte)										
Port 1	Same as Port 0								4320	0x10E0	13
Port 2	Same as Port 0								4336	0x10F0	13
Port 3	Same as Port 0								4352	0x1100	13
Port 4	Same as Port 0								4368	0x1110	13
Port 5	Same as Port 0								4384	0x1120	13
Port 6	Same as Port 0								4400	0x1130	13
Port 7	Same as Port 0								4416	0x1140	13
Port 8	Same as Port 0								4432	0x1150	13
Port 9	Same as Port 0								4448	0x1160	13
Port 10	Same as Port 0								4464	0x1170	13
Port 11	Same as Port 0								4480	0x1180	13

# PCH Portal Function

## 4.3.6.1 Data Storage

This parameter defines the behaviour of Parameter Server (Data Storage) of the IO-Link. This parameter has values as given in Table 34.

**Table 33** — Data Storage

Option	Value (Dec)
Disable	64
Upload	129
Download	130
Upload + Download	131
Clear	32

## 4.3.6.2 Validation Type

This parameter defines the behaviour of Validation Type of the IO-Link. This parameter has values as given in Table 35.

**Table 34** — Validation Type

Option	Value (Dec)
No Validation	0
Compatible	1
Identical	2

## 4.3.6.3 Cycle Time

This parameter can be used to influence the IO-Link communication speed. Calculated using the multiplier and the time base, the IO-Link cycle time can be increased.

The time base is described in Table 36. The multiplier is entered in decimal from 0...63.

**Bit 0 to 5: Multiplier:** These bits contain a 6-bit multiplier for the calculation of master cycle time or Min Cycle Time. Permissible values for the multiplier are 0 to 63.

**Bit 6 to 7: Time Base:** These bits specify the time base for the calculation of master cycle time or min cycle time.

Possible values of master cycle time or min cycle time

**Table 35** — Cycle Time Calculation

Time Base Encoding	Time Base Value	Calculation	Cycle Time
00	0.1 ms	Multiplier x time base	0.4 ms to 6.3 ms
01	0.4 ms	6.4 ms + multiplier x time base	6.4 ms to 31.6 ms
10	1.6 ms	32.0 ms + multiplier x time base	32.0 ms to 132.8 ms
11	RESERVED		

**NOTE:** The value 0.4 results from the minimum possible transmission time.

**NOTE:** Write in 13 registers to configure an IO-Link Port.

# PCH Portal Function

**Example:** To configure Port 0 as given in Table 37, write the following 13 values starting from register address 4305 as given in Table 38.

**Table 36** — Example IO-Link Configuration

Field	Configuration	Value (Hex)
Parameter Server	Upload Enable	81
Validation Type	Identical	2
Vendor ID	Parker	010F
Device ID	P2M Module	061F00
Cycle Time	132.8 ms	BF
Serial No	4217-0-0052	34 32 31 37 2D 30 2D 30 30 35 32

**Table 37** — Example IO-Link Configuration

Value (Hex)	Offset	
	Dec	Hex
0x0081	4304	0x10D0
0x0002	4305	0x10D1
0x0F01	4306	0x10D2
0x1F06	4307	0x10D3
0xBF00	4308	0x10D4
0x3234	4309	0x10D5
0x3731	4310	0x10D6
0x302D	4311	0x10D7
0x302D	4312	0x10D8
0x3530	4313	0x10D9
0x0032	4314	0x10DA
0x0000	4315	0x10DB
0x0000	4316	0x10DC

---

**NOTE:** Module Parameterization must be 1 for configuration to get applied.

---

# PCH Portal Function

## 4.4 Process Data Inputs

The Process Input Data Registers can be accessed (Read Only) as single register or multiple registers (each register contains 16-bit (2 Bytes) information) or can be accessed as bitwise (single or multiple bit). Refer Appendix A for bitwise access register addresses.

1. Process Input Data Registers can be accessed using the function code 04 to read the single or multiple registers.
2. Master/PLC adds the below offsets to the base address while accessing the registers.

Example: If the 5-digit addressing is used by master/PLC and base address of Input Register is decimal 30000, then Discrete Input Channel Data Address is decimal 30005 to 30006.

3. Reserved fields are read as 0.

The following Data Map (DM) describes the process input map for Modbus TCP.

### 4.4.1 Device Status Bytes

The Status Bytes are used to diagnose the PCH Portal. It will help in identifying the faults and warnings that will be reported by the device.

**NOTE:** For an explanation of the behaviour of the diagnostic Status Bytes, please refer to “Process Input Status Bits” under Table 56 .

**Table 38 — Device Status Byte**

Module	Bit 7	Bit 6	Bit 5	Bit 4	Bit 3	Bit 2	Bit 1	Bit 0	Offset	Word Count
									Dec (Hex)	
Status Bytes	External Module	RESV	Valve	IO / IO-Link	Network	Logic Voltage	Auxiliary Voltage	MS/ CoProc	0 0x0000	6
	Target Count	External Sensor Power Fault	Temperature Warning	Auxiliary Current	Logic Current	Trending Data	Warning	Error		
Fuse/ Over Current Status	RESV	RESV	RESV	OC3	OC2	OC1	OC	FS	1 0x0001	
Reserved	RESV									
Valve Fault Status	VF07	VF06	VF05	VF04	VF03	VF02	VF01	VF00	2 0x0002	
	VF15	VF14	VF13	VF12	VF11	VF10	VF09	VF08		
	VF23	VF22	VF21	VF20	VF19	VF18	VF17	VF16	3 0x0003	
	VF31	VF30	VF29	VF28	VF27	VF26	VF25	VF24		
Reserved	RESV	RESV	RESV	RESV	RESV	RESV	RESV	RESV	4 0x0004	
	RESV	RESV	RESV	RESV	RESV	RESV	RESV	RESV		
	RESV	RESV	RESV	RESV	RESV	RESV	RESV	RESV	5 0x0005	
	RESV	RESV	RESV	RESV	RESV	RESV	RESV	RESV		

# PCH Portal Function

Description of Device Status sections are as follows:

## 4.4.1.1 Status Bytes

A bit SET indicates fault condition.

Example: When the Logic Voltage is in warning range (19.V to 20.4V), the Logic Voltage and Warning Bits are SET.

## 4.4.1.2 Fuse and Over Current Status

1. **Fuse Status (FS):** A shorted condition of Pin-1 to common/ground will open the (FS) fuse and SET FS bit.
2. **Over Current (OC):** A shorted condition of Pin-2 or Pin-4 to common/ground with the output ON will latch the OC bit.
3. **Module Over Current (OC1, OC2, OC3):** These bits are set according to the board on which short condition occurred.

Example: When Over Current is occurs at Port 5B, OC2 and OC bits get SET. When Over Current condition is removed OC2 bit gets RESET, but OC bit remains SET.

## 4.4.1.3 Valve Fault Status

A bit set in this region indicates short circuit/ over current condition in corresponding valve.

## 4.4.2 IO-Link Status Bytes

**Table 39 — IO-Link Status Byte**

Port No.	Bit 7	Bit 6	Bit 5	Bit 4	Bit 3	Bit 2	Bit 1	Bit 0	Offset		Word Count
									Dec	Hex	
Port 0	RESV	EV	SC	PDI	DF	VF	DC	IOL	6	0x0006	3
	Vendor ID Byte 1 (Higher Byte)										
	Vendor ID Byte 2 (Lower Byte)								7	0x0007	
	Device ID Byte 1 (Higher Byte)										
	Device ID Byte 2 (Middle Byte)										
Device ID Byte 3 (Lower Byte)								8	0x0008		
Port 1	Same as Port 0								9	0x0009	3
Port 2	Same as Port 0								12	0x000C	3
Port 3	Same as Port 0								15	0x000F	3
Port 4	Same as Port 0								18	0x0012	3
Port 5	Same as Port 0								21	0x0015	3
Port 6	Same as Port 0								24	0x0018	3
Port 7	Same as Port 0								27	0x001B	3
Port 8	Same as Port 0								30	0x001E	3
Port 9	Same as Port 0								33	0x0021	3
Port 10	Same as Port 0								36	0x0024	3
Port 11	Same as Port 0								39	0x0027	3

# PCH Portal Function

Description of IO-Link Status Bytes are as follows:

- **IOL:** This bit is SET when the port is configured as IO-Link.
- **DC:** This bit is SET when IO-Link slave device is connected to the port.
- **VF:** This bit is SET when Inspection Level Failure condition is generated at the port.
- **DF:** This bit is SET when Data Storage Failure condition is generated at the port.
- **PDI:** This bit is SET when Process Data of connected IO-Link slave device is invalid.
- **SC:** This bit is SET when C/Q line of IO-Link device is shorted to ground.
- **EV:** This bit is SET when Port contains unread IO-Link Slave Events. This bit gets reset when Master reads IO-Link Events of corresponding port or IO-Link Slave is disconnected.
- **Vendor ID:** This field contains two bytes Vendor ID of connected IO-Link Slave.
- **Device ID:** This field contains three bytes Device ID of connected IO-Link Slave.

## 4.4.3 Standard Discrete Inputs

**Table 40** — Standard Discrete Inputs

Bit 7	Bit 6	Bit 5	Bit 4	Bit 3	Bit 2	Bit 1	Bit 0	Offset		Word Count
								Dec	Hex	
I3B	I3A	I2B	I2A	I1B	I1A	I0B	I0A	42	0x002A	2
I7B	I7A	I6B	I6A	I5B	I5A	I4B	I4A			
I11B	I11A	I10B	I10A	I9B	I9A	I8B	I8A	43	0x002B	
RESV	RESV	RESV	RESV	RESV	RESV	RESV	RESV			

A bit which is SET indicates that the corresponding Input is active. If a port is configured as DO/IO-Link, then the bit corresponding to that port remains RESET.

## 4.4.4 IO-Link Input Process Data

**Table 41** — IO-Link Input Process Data

Bit 7	Bit 6	Bit 5	Bit 4	Bit 3	Bit 2	Bit 1	Bit 0	Address		Word Count
								Dec	Hex	
Port 0 IO-Link Input Process Data								44	0x002C	16
Port 1 IO-Link Input Process Data								60	0x003C	16
Port 2 IO-Link Input Process Data								76	0x004C	16
Port 3 IO-Link Input Process Data								92	0x005C	16
Port 4 IO-Link Input Process Data								108	0x006C	16
Port 5 IO-Link Input Process Data								124	0x007C	16
Port 6 IO-Link Input Process Data								140	0x008C	16
Port 7 IO-Link Input Process Data								156	0x009C	16
Port 8 IO-Link Input Process Data								172	0x00AC	16
Port 9 IO-Link Input Process Data								188	0x00BC	16
Port 10 IO-Link Input Process Data								204	0x00CC	16
Port 11 IO-Link Input Process Data								220	0x00DC	16

# PCH Portal Function

## 4.5 Process Data Outputs

The Process Output Data Registers can be accessed (Read/Write) as single register or multiple registers (each register contains 16-bit information) or can be accessed as bitwise (single bit or multiple bits). Refer Appendix B for reading/writing the output data bitwise.

1. Process Output Data Registers can be accessed using the function code as follows:
  - a. Function Code 03: To Read the single or multiple registers.
  - b. Function Code 06: To Write single register.
  - c. Function Code 16: To Write multiple registers.
  - d. Function Code 23: To Write and read multiple registers.
2. Master/PLC adds the below offset to the base address while accessing the registers.

Example: If the 5-digit addressing is used by master/PLC and base address of Holding Register is decimal 40000, then Discrete Output Data Address is decimal 40000 to 40001.

3. Values written to reserved bytes is ignored.

The following DM describes the process output map for Modbus TCP.

### 4.5.1 Standard Discrete Output and Device Control

Table 42 — Standard Discrete Output and Device Control

Bit 7	Bit 6	Bit 5	Bit 4	Bit 3	Bit 2	Bit 1	Bit 0	Offset		Word Count
								Dec	Hex	
O3B	O3A	O2B	O2A	O1B	O1A	O0B	O0A	0	0x0000	2
O7B	O7A	O6B	O6A	O5B	O5A	O4B	O4A			
O11B	O11A	O10B	O10A	O9B	O9A	O8B	O8A	1	0x0001	
RESV	RESV	RESV	RESV	RESV	RESV	RESV	RST			

#### 4.5.1.1 Standard Output (O0A to O11B)

Writing 1 to a bit result in corresponding DO actuation. If a Port is configured as IO-Link, writing value to the bit corresponding to that port has no effect.

#### 4.5.1.2 Device Control

**Reset Event (RST):** A 0 to 1 transition clears the OC bit. OC bit is cleared only if neither of the OC1, OC2 or OC3 bit are SET.

# PCH Portal Function

## 4.5.2 Valve Outputs

**Table 43 — Valve Outputs**

Bit 7	Bit 6	Bit 5	Bit 4	Bit 3	Bit 2	Bit 1	Bit 0	Offset		Word Count
								Dec	Hex	
V07	V06	V05	V04	V03	V02	V01	V00	2	0x0002	2
V15	V14	V13	V12	V11	V10	V09	V08			
V23	V22	V21	V20	V19	V18	V17	V16	3	0x0003	
V31	V30	V29	V28	V27	V26	V25	V24			

### 4.5.2.1 Valve Outputs (V00 to V31)

Writing 1 to a bit result in corresponding Valve actuation.

## 4.5.3 IO-Link Output Process Data

**Table 44 — IO-Link Output Process Data**

Bit 7	Bit 6	Bit 5	Bit 4	Bit 3	Bit 2	Bit 1	Bit 0	Offset		Word Count
								Dec	Hex	
Port 0 IO-Link Output Process Data								4	0x0004	16
Port 1 IO-Link Output Process Data								20	0x0014	16
Port 2 IO-Link Output Process Data								36	0x0024	16
Port 3 IO-Link Output Process Data								52	0x0034	16
Port 4 IO-Link Output Process Data								68	0x0044	16
Port 5 IO-Link Output Process Data								84	0x0054	16
Port 6 IO-Link Output Process Data								100	0x0064	16
Port 7 IO-Link Output Process Data								116	0x0074	16
Port 8 IO-Link Output Process Data								132	0x0084	16
Port 9 IO-Link Output Process Data								148	0x0094	16
Port 10 IO-Link Output Process Data								164	0x00A4	16
Port 11 IO-Link Output Process Data								180	0x00B4	16

# PCH Portal Function

## 4.6 Diagnostics

1. Diagnostic Data Registers can be accessed using the function code 04 to read the single or multiple registers.
2. Master/PLC adds the below offset to the base address while accessing the registers.  
Example: If the 5-digit addressing is used by master/PLC and base address of Input Register is decimal 30000, then Diagnostic Data Registers Address is decimal 32048 to 32054.

**Table 45 — Diagnostics**

Module	Bit 7	Bit 6	Bit 5	Bit 4	Bit 3	Bit 2	Bit 1	Bit 0	Offset		Word Count
									Dec	Hex	
Event Count	RESV								2048	0x0800	7
	Diagnostic Event Count										
Event #1	Event Code								2049	0x0801	
	RESV	Severity			RESV	RESV	RESV	RESV			
Event #2	Same as Event #1								2050	0x0802	
Event #3	Same as Event #1								2052	0x0804	
Event #4	Same as Event #1								2051	0x0803	
Event #5	Same as Event #1								2052	0x0804	
Event #6	Same as Event #1								2053	0x0805	

**Diagnostic Event Count:** Provides count of total pending events which are not cleared.

**Event Code:** Value of this field is always 0xFF.

**Severity:** Table 47 describes the severity levels.

**Table 46 — Severity Levels**

Bit Combination	Severity	Comment
000	Minor, Recoverable	---
001	Minor, Un-Recoverable	Un-recoverable events cannot be deleted
010	Major, Recoverable	---
011	Major, Un-Recoverable	Causes a state shift to EXCEPTION

# PCH Portal Function

## 4.7 Acyclic Communication

PCH Portal provides Acyclic Communication method to access errors/warnings/IO-Link parameters. The Acyclic Communication Data registers can be accessed (Read/Write) as multiple registers (each register has 16-bit information).

1. Acyclic Data can be accessed using the function code as follows:
  - a. Function Code 03: To Read the single or multiple registers.
  - b. Function Code 06: To Write single register.
  - c. Function Code 16: To Write multiple registers.
  - d. Function Code 23: To Write and read multiple registers.
2. All the address for the registers specified in the table are offsets.
3. Master/PLC adds the offset to the base address while accessing (Read or Write) the registers.  
Example: If the 5-digit addressing is used by master/PLC and base address of Holding Register is decimal 40000, then Logic Voltage Diagnostic address is decimal 44512
4. The values written to reserved bytes is ignored.

The following table provides class, instance and attribute details required to read diagnostic data from PCH Portal.

**Table 47 — Acyclic Diagnostics**

Module	Bit 7	Bit 6	Bit 5	Bit 4	Bit 3	Bit 2	Bit 1	Bit 0	Access Type	Offset Dec (Hex)	Word Count
Aux Voltage	RESV				Auxiliary Voltage Warning Level		Auxiliary Voltage Fault Level		RO	4496 0x1190	2
	RESV										
	Auxiliary Voltage Reading in mV (Higher Byte)										
	Auxiliary Voltage Reading in mV (Lower Byte)										
Logic Voltage	RESV				Logic Voltage Warning Level		Logic Voltage Fault Level		RO	4512 0x11A0	2
	RESV										
	Logic Voltage Reading in mV (Higher Byte)										
	Logic Voltage Reading in mV (Lower Byte)										
MS / Co-Proc	RESV										
	RESV						Database Initialization Failed	Backplane Initialization Failed	RO	4528 0x11B0	
	RESV								RO	4529 0x11B1	
	RESV						Backplane Break <Warning>	Backplane Break <Fault>	RO		
	RESV				Watch Dog Expired Warning / Fault		Watch Dog Expired Module		RO	4530 0x11B2	

# PCH Portal Function

Module	Bit 7	Bit 6	Bit 5	Bit 4	Bit 3	Bit 2	Bit 1	Bit 0	Access Type	Offset Dec (Hex)	Word Count	
	Module Position - Watch Dog Expired								RO			
Valve	VCL 07	VCL 06	VCL 05	VCL 04	VCL 03	VCL 02	VCL 01	VCL 00	RO	4544 0x11C0	2	
	VCL 15	VCL 14	VCL 13	VCL 12	VCL 11	VCL 10	VCL 09	VCL 08				
	VCL 23	VCL 22	VCL 21	VCL 20	VCL 19	VCL 18	VCL 17	VCL 16				
	VCL 31	VCL 30	VCL 29	VCL 28	VCL 27	VCL 26	VCL 25	VCL 24				
	RST 07	RST 06	RST 05	RST 04	RST 03	RST 02	RST 01	RST 00	WO	4560 0x11D0	2	
	RST 15	RST 14	RST 13	RST 12	RST 11	RST 10	RST 09	RST 08				
	RST 23	RST 22	RST 21	RST 20	RST 19	RST 18	RST 17	RST 16				
	RST 31	RST 30	RST 29	RST 28	RST 27	RST 26	RST 25	RST 24				
		RESV				Valve Driver SPI Communication/ Auxiliary Power Supply Warning				RO	4576 0x11E0	2
		RESV										
	RESV				Valve Driver SPI Communication/ Auxiliary Power Supply Error				RO	4578 0x11E2		
	RESV						EEPROM Corrupt	EEPROM - I2C Comm. Error	RO			
Digital Inputs	ICL 03B	ICL 03A	ICL 02B	ICL 02A	ICL 01B	ICL 01A	ICL 00B	ICL 00A	RO	4592 0x11F0	2	
	ICL 07B	ICL 07A	ICL 06B	ICL 06A	ICL 05B	ICL 05A	ICL 04B	ICL 04A				
	ICL 11B	ICL 11A	ICL 10B	ICL 10A	ICL 09B	ICL 09A	ICL 08B	ICL 08A				
		RESV									4593 0x11F1	
	RST 03B	RST 03A	RST 02B	RST 02A	RST 01B	RST 01A	RST 00B	RST 00A	WO	4608 0x1200	2	
	RST 07B	RST 07A	RST 06B	RST 06A	RST 05B	RST 05A	RST 04B	RST 04A				
	RST 11B	RST 11A	RST 10B	RST 10A	RST 09B	RST 09A	RST 08B	RST 08A				
	RESV									4609 0x1201		
Digital Outputs	OCL 03B	OCL 03A	OCL 02B	OCL 02A	OCL 01B	OCL 01A	OCL 00B	OCL 00A	RO	4624 0x1210	2	
	OCL 07B	OCL 07A	OCL 06B	OCL 06A	OCL 05B	OCL 05A	OCL 04B	OCL 04A				
	OCL 11B	OCL 11A	OCL 10B	OCL 10A	OCL 09B	OCL 09A	OCL 08B	OCL 08A				
		RESV									4625 0x1211	
	RST 03B	RST 03A	RST 02B	RST 02A	RST 01B	RST 01A	RST 00B	RST 00A	WO	4640 0x1220	2	
	RST 07B	RST 07A	RST 06B	RST 06A	RST 05B	RST 05A	RST 04B	RST 04A				
	RST 11B	RST 11A	RST 10B	RST 10A	RST 09B	RST 09A	RST 08B	RST 08A				
	RESV									4641 0x1221		
I/O/ IO-Link	RESV									4656 0x1230	3	
	ADC - I2C Communication Warning - Module Position								RO			

# PCH Portal Function

Module	Bit 7	Bit 6	Bit 5	Bit 4	Bit 3	Bit 2	Bit 1	Bit 0	Access Type	Offset Dec (Hex)	Word Count
I/O/ IO-Link	IO-Link Transceiver - USART 1 Communication Warning - Module Position								RO	4657 0x1231	6
	IO-Link Transceiver - USART 2 Communication Warning - Module Position								RO		
	IO-Link Transceiver - USART 3 Communication Warning - Module Position								RO	4658 0x1232	
	IO-Link Transceiver - USART 4 Communication Warning - Module Position								RO		
	RESV									4672 0x1240	
	External Flash Corrupt - Module Position								RO		
	ADC - I2C Communication Error - Module Position								RO	4673 0x1241	
	IO-Link Transceiver - SPI Communication Error - Module Position								RO		
	IO-Link Transceiver - USART 1 Communication Error - Module Position								RO	4674 0x1242	
	IO-Link Transceiver - USART 2 Communication Error - Module Position								RO		
	IO-Link Transceiver - USART 3 Communication Error - Module Position								RO	4675 0x1243	
	IO-Link Transceiver - USART 4 Communication Error - Module Position								RO		

# PCH Portal Function

Module	Bit 7	Bit 6	Bit 5	Bit 4	Bit 3	Bit 2	Bit 1	Bit 0	Access Type	Offset Dec (Hex)	Word Count
I/O/ IO-Link	External Module - Error - Module Position								RO	4676 0x1244	
	Fuse Status - Fault - Module Position								RO		
	Over Current - Fault - Module Position								RO	4677 0x1245	
	Over Current - Fault - Channel No								RO		
Network	RESV						PLC - Output Access	IP Address	RO	4992 0x1380	1
	RESV										

Description of various fields are as follows:

## 4.7.1 Auxiliary and Logic Voltage

### Auxiliary/ Logic Voltage Fault and Warning Levels

- (00)<sub>b</sub> - No Fault and Warning
- (01)<sub>b</sub> - Low
- (10)<sub>b</sub> - High
- (11)<sub>b</sub> – No Supply or Low/High Voltage Cut-off.

**Auxiliary/ Logic Voltage Readings:** This field holds the present voltage value in mV.

Example: Voltage value of 23.4V (23400 mV) is read as 0x685B.

## 4.7.2 MS/Co-Proc

### Device Start-up Fail:

- 0 - No Failure
- 1 – Failure

### Backplane Break Fault/Warning:

- 0 - No Break
- 1 - Break

### Watch Dog Expired - Module:

- (00)<sub>b</sub> - No Error
- (01)<sub>b</sub> - CoProc
- (10)<sub>b</sub> - Valve
- (11)<sub>b</sub> - IO Module

**Watch Dog Expired - Warning/Fault:**

- (00)<sub>b</sub> - No Warning/Fault
- (01)<sub>b</sub> - Warning
- (10)<sub>b</sub> - Fault
- (11)<sub>b</sub> - Reserved

**Module Position. Watch Dog Expired:**

- 0 - No Watch Dog Expired
- 1 - 3 - Module Position
- 4 - 255 - Reserved

### 4.7.3 Valve

**Cycle Count Limit Reached (VCL):**

- 0 - No Cycle Count Limit Reached
- 1 - Cycle Count Limit Reached

---

**NOTE:** On Cycle Count Limit Reached, the corresponding VCL bit is SET for 2 seconds and then gets RESET.

---

**Cycle Count Reset (RST):**

- 0 - No Change
- 1 - Set to Reset the Cycle Count

**Valve Driver - SPI Communication/ Auxiliary Power Supply Warning/Fault:** This field consist of four bits each bit corresponds to a valve driver. A bit SET indicates the fault in corresponding valve driver.

- Bit 0 – Valve driver 1
- Bit 1 – Valve driver 2
- Bit 2 – Valve driver 3
- Bit 3 – Valve driver 4

For the following fields 0 indicate no error and 1 indicate fault/warning condition

- EEPROM - I2C Communication Fault
- EEPROM - Corrupt

### 4.7.4 Digital Inputs

**Cycle Count Limit Reached (ICL):**

- 0 - No Cycle Count Limit Reached
- 1 - Cycle Count Limit Reached

---

**NOTE:** On Cycle Count Limit Reached, the corresponding ICL bit is set for 2 seconds and then gets RESET.

---

**Cycle Count Reset (RST):**

- 0 - No Change
- 1 - Set to Reset the Cycle Count

# PCH Portal Function

---

## 4.7.5 Digital Outputs

### **Cycle Count Limit Reached (OCL):**

- 0 - No Cycle Count Limit Reached
- 1 - Cycle Count Limit Reached

---

**NOTE:** On Cycle Count Limit Reached, the corresponding OCL bit is set for 2 seconds and then gets RESET.

---

### **Cycle Count Reset (RST):**

- 0 - No Change
- 1 - Set to Reset the Cycle Count

## 4.7.6 I/O/IO-Link

For the following fields value of 0 indicate No Error. Value between 1-3 indicate Module Position of fault generated, and 4-255 are Reserved.

- ADC - I2C Communication Warning
- IO-Link Transceiver - USART - 1 Communication Warning
- IO-Link Transceiver - USART - 2 Communication Warning
- IO-Link Transceiver - USART - 3 Communication Warning
- IO-Link Transceiver - USART - 4 Communication Warning
- EEPROM - SPI Communication Fault
- ADC - I2C Communication Fault
- IO-Link Transceiver - SPI Communication Fault
- IO-Link Transceiver - USART - 1 Communication Fault
- IO-Link Transceiver - USART - 2 Communication Fault
- IO-Link Transceiver - USART - 3 Communication Fault
- IO-Link Transceiver - USART - 4 Communication Fault
- External Module - Fault
- Fuse Status - Fault
- Over Current - Fault - Module Position

### **Over Current - Fault - Channel Number:**

- 0 - 23 Channel No  
(Refer to Table 16 for Channel Description)

## 4.7.7 Network

### **IP Address:**

- 0 - Valid IP Address
- 1 - Invalid IP Address

### **PLC - Output Access:**

- 0 - Access Enabled.
- 1 - Access Disabled.

# PCH Portal Function

## 4.8 A Module cyclic Services

### 4.8.1 A Module cyclic Read Service

**Table 48 — IO-Link Acyclic Read**

Module	Parameter	Access Type	Offset		Word Count
			Dec	Hex	
Read Request	Port Number (0 to 11)	RW	4816	0x12D0	3
	Index	RW	4817	0x12D1	
	Sub-Index	RW	4818	0x12D2	
Read Response	Read Response	RO	4704	0x1260	1
	Data/Error Code	RO	4705	0x1261	111

When read request is successful, Error indicator field contains 0 and Data/Error code field contains response to the request, otherwise error indicator field contains 0x8000 and Data/Error code field contains the error code.

**NOTE:** Response to Read Request might take up to 40 seconds to reflect on registers.

Example: To read Index = 24, Sub-Index = 0 of Port 1 following steps are to be followed

1. A read request is written to the device as given in the Table 50.

**Table 49 — Example for IO-Link Read Request**

Parameter	Value (Hex)	Offset	
		Dec	Hex
Port Number	0x0001	4816	0x12D0
Index	0x0018	4817	0x12D1
Sub-Index	0x0000	4818	0x12D2

2. Response to the request contains the requested data starting at offset 4705. Up to 222 bytes of data can be read.

**Table 50 — Example IO-Link Read Response**

Area	Value in Hex	Offset	
		Dec	Hex
Error Indicator	0x0000	4704	0x1260
Data/Error Code	Data	4705	0x1261

# PCH Portal Function

## 4.8.2 A Module cyclic Write Service

**Table 51 — IO-Link Acyclic Write**

Module	Parameter	Access Type	Offset		Word Count
			Dec	Hex	
Write Request	Port Number	RW	4848	0x12F0	1
	Index	RW	4849	0x12F1	1
	Sub-Index	RW	4850	0x12F2	1
	Data Size in bytes	RW	4851	0x12F3	1
	Data	RW	4852	0x12F4	108
Write Response	Error Indicator	RO	4832	0x12E0	2
	Error Code (Upper Byte)	RO	4833	0x12E1	
	Error Code (Lower Byte)	RO			

**NOTE:** 1. To write Data, registers must be written in multiples of 16 starting from 4848.  
2. Response to Write Request might take up to 40 seconds to reflect on registers.

When write request is successful, Error indicator and Error code field contains 0, otherwise error indicator field contains 0x8000 and Error code field contains the error code.

Example: To write "PARKER" at Index = 24, Sub-Index = 0 of Port 1 following steps are to be followed:

1. A write request must be sent with the values as provided in the Table 53.

**Table 52 — Example for IO-Link Write**

Parameter	Value (Hex)	Offset	
		Dec	Hex
Port Number	0x0001	4848	0x12F0
Index	0x0018	4849	0x12F1
Sub-Index	0x0000	4850	0x12F2
Data Size in Bytes	0x0006	4851	0x12F3
Data	0x4150	4852	0x12F4
	0x7552	4853	0x12F5
	0x5245	4854	0x12F6
	0x0000	4855	0x12F7
	0x0000	4856	0x12F8
	0x0000	4857	0x12F9
	0x0000	4858	0x12FA
	0x0000	4859	0x12FB
	0x0000	4860	0x12FC
	0x0000	4861	0x12FD
	0x0000	4862	0x12FE
	0x0000	4863	0x12FF

# PCH Portal Function

2. Read the response at register 4832. If the Write is successful, value read is 0 and the Value read as 0x8000 is considered as failure of write operation and error code is read at 4833.

**Table 53** — Example IO-Link Write Response

Area	Value in Hex	Offset	
		Dec	Hex
Error Indicator	0x0000	4832	0x12E0
Error Code	0x0000	4833	0x12E1

## 4.9 IO-Link Events

IO-Link Slave events of slave which is currently connected to the port can be read via PLC/ Master. Frame format for request and response is given in the following table.

**Table 54** — IO-Link Events

Module	Parameter	Access Type	Offset		Word Count
			Dec	Hex	
Event Read Request	Port Number	RW	5168	0x1430	1
Event Read Response	RESV	RO	5056	0x13C0	1
	Number of IO-Link Events				
	RESV	RO	5057	0x13C1	1
	Size of each IO-Link Event in bytes				
IO-Link Event 1 to 30 (210 Bytes)	RO	5058	0x13C2	105	

Format of an IO-Link Event is as given in the following table.

**Table 55** — Structure of an IO-Link

Module	Bit 7	Bit 6	Bit 5	Bit 4	Bit 3	Bit 2	Bit 1	Bit 0
Timestamp	Event Timestamp Byte 1 (Higher Byte)							
	Event Timestamp Byte 2							
	Event Timestamp Byte 3							
	Event Timestamp Byte 4 (Lower Byte)							
Event Qualifier	Mode		Type		Source	Instance		
Event Code	Event Code (Higher Byte)							
	Event Code (Lower Byte)							

**NOTE:** Refer Appendix C for the definition of Event Qualifier and Event Code.

# PCH Portal Function

---

Example: To read the events of Port 1:

1. Write value 1 into register 5168.
2. Read registers 5056 and 5057 to obtain number of IO-Link Events present on the port and size of each IO-Link Event.  
For example, number of IO-Link events present at port be 4 and size of each events be 7 bytes.  
Based on this information, total size of IO-Link event data is  $4 * 7 = 28$  bytes = 14 Modbus Registers.
3. Read 14 Modbus registers starting from address 5058.

## CHAPTER - 5 **Configuration Tool/Web Interface**

# Configuration Tool/Web Interface

The PCH Portal provides the following interfaces for configuration and monitoring of PCH Portal.

## 5.1 The PC Configuration Tool/Web Interface

The PC Configuration tool is Windows PC based application that communicates over USB and Bluetooth Interface to the PCH Portal.

To connect the PC configuration tool via USB interface connect the cable between the PC and PCH Portal and launch PCH Portal Configuration Tool to get connected with the PCH Portal.

To connect PCH Portal web page via Ethernet interface connect the ethernet cable between the PC and PCH Portal and enter the PCH Portal's IP address in the browser.

User can select preferred language from the language dropdown. Supported languages are English, French, German, Italian, Chinese, Korean and Japanese.

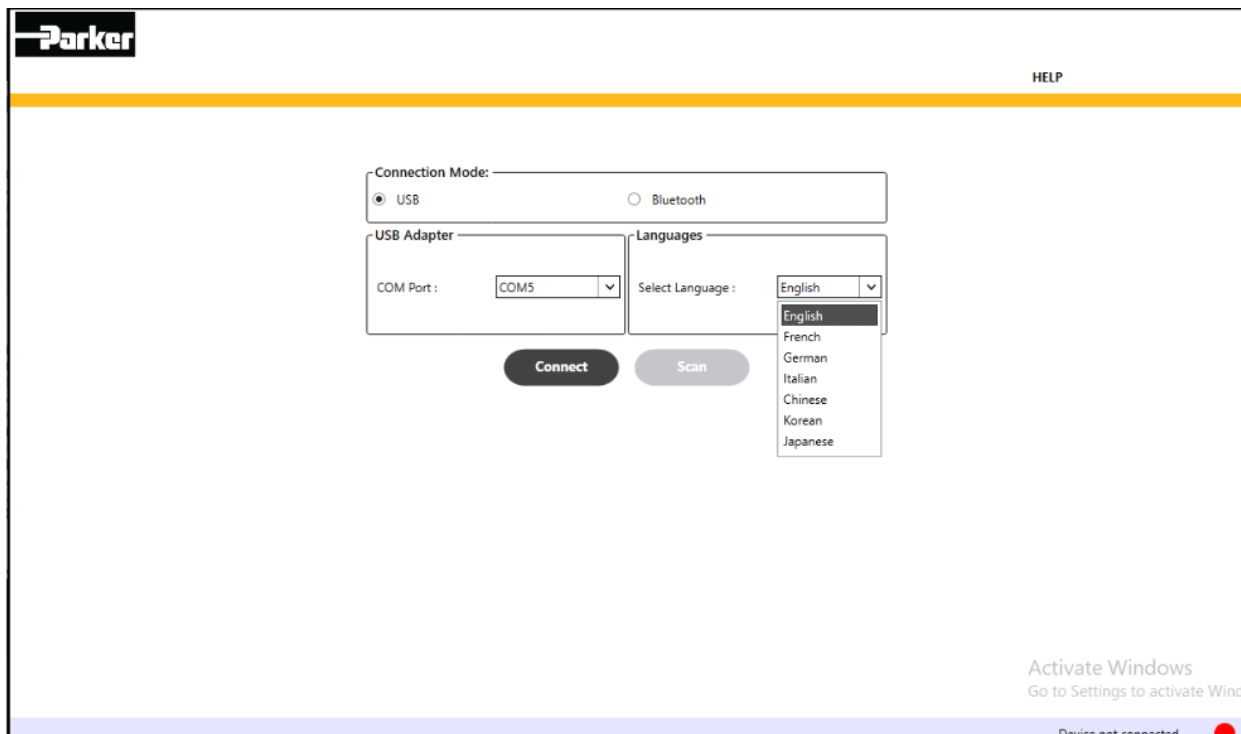

**Figure 16** — PC Configuration Tool

To connect PC configuration tool via Bluetooth interface, a low energy USB Dongle (BLED112) must be connected to USB port of Windows PC. Also, turn ON the Bluetooth on the PCH Portal by pressing the Bluetooth button for at least 3 seconds.

Select the 'Bluetooth' radio button on the screen. This will enable the 'Scan' button on the UI. To connect to the PCH Portal, click on the 'Scan' button. After scan is completed the available PCH Portal devices will be shown. The PCH Portal device can be identified using the device name displayed in the scan device list. The PCH Portal device name will be displayed as PCH-XXXX where XXXX is the last 4 digits of the MAC address printed on the label of the PCH Portal.

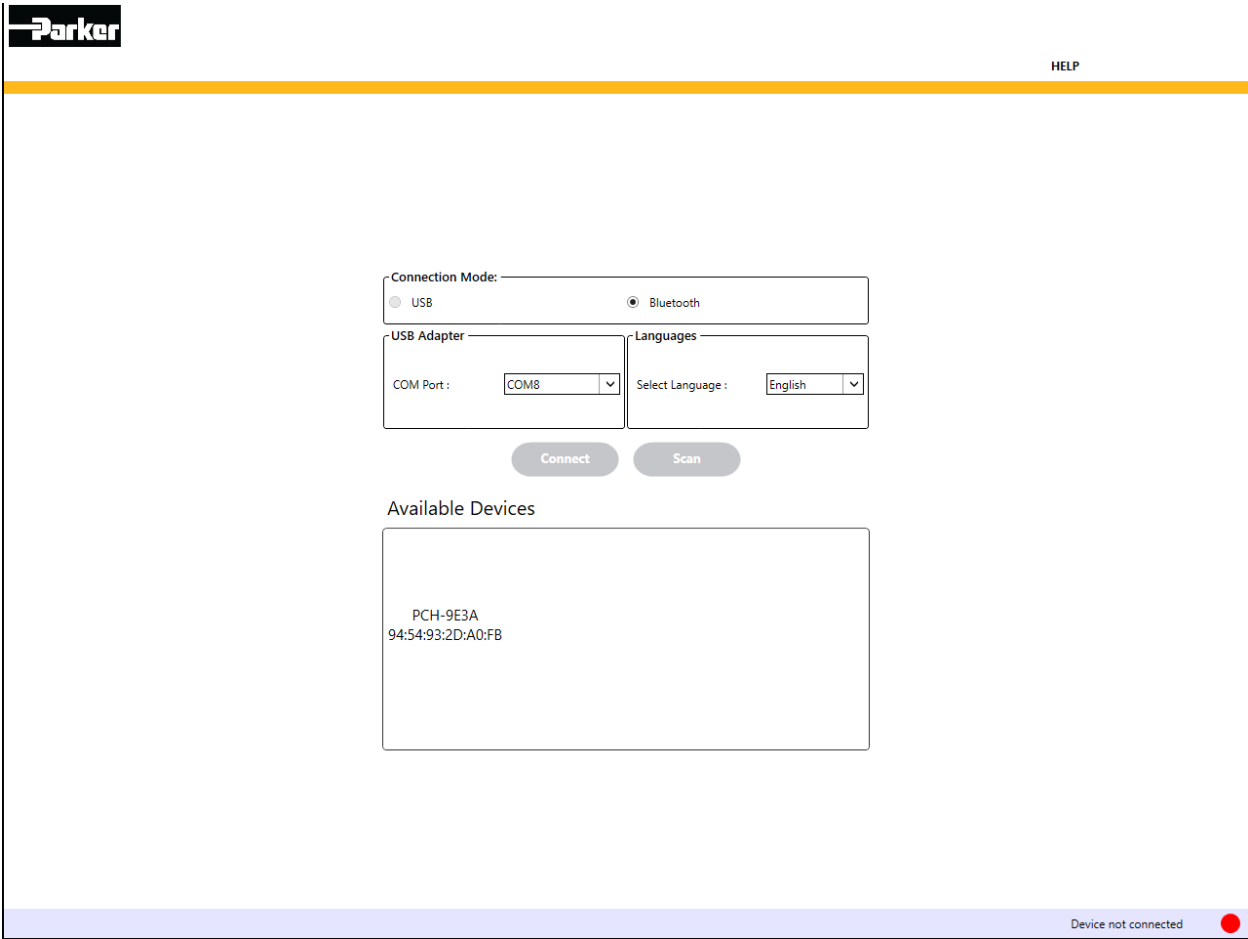

Figure 17 — Bluetooth connection screen

# Configuration Tool/Web Interface

The screenshot shows the Parker PCH Portal web interface. At the top, there is a browser address bar showing '192.168.1.99'. The Parker logo is in the top left. A navigation bar contains 'STATUS' (selected) and 'CONFIGURATION' tabs. A language dropdown menu is open, showing options: English, Italian, French, German, Chinese, Korean, and Japanese. The main content area is titled 'Status' and shows the device 'PCH10MBAB0-P4' with an image of the device. Below the image is a table of valve status:

Address	Valve Tag	Connect	State	Address	Valve Tag	Connect	State
0	EV0	OFF	Green	16	EV16	OFF	Green
1	EV1	OFF	Green	17	EV17	OFF	Green
2	EV2	OFF	Green	18	EV18	OFF	Green
3	EV3	OFF	Green	19	EV19	OFF	Green
4	EV4	OFF	Green	20	EV20	OFF	Green
5	EV5	OFF	Green	21	EV21	OFF	Green
6	EV6	OFF	Green	22	EV22	OFF	Green
7	EV7	OFF	Green	23	EV23	OFF	Green
8	EV8	OFF	Green	24	EV24	OFF	Green
9	EV9	OFF	Green	25	EV25	OFF	Green
10	EV10	OFF	Green	26	EV26	OFF	Green
11	EV11	OFF	Green	27	EV27	OFF	Green
12	EV12	OFF	Green	28	EV28	OFF	Green
13	EV13	OFF	Green	29	EV29	OFF	Green
14	EV14	OFF	Green	30	EV30	OFF	Green
15	EV15	OFF	Green	31	EV31	OFF	Green

To the right of the valve table is a 'Device Information' table:

Device Name	
Protocol	
IP Address	192.168.1.99
Bluetooth	OFF
DHCP	Disabled
Total Current Available	Logic 0.35 A Aux < 12 A
Maximum Current	Logic 8.00 A Aux 12.00 A
Configuration Data Bytes	390
Bytes Produced	500
Bytes Consumed	492
Serial Number	ABCD1234

Below these tables are two more tables showing LED status:

LED	Status	Value	Description
Aux Power	Green	24.03 V	Connected and within Limit
Logic Power	Green	24.79 V	Connected and within Limit
Bluetooth	Grey	---	OFF
Device Status	Green	---	Normal

LED	Status	Description
Port 1 LINK/Activity Status	Green	Link (100 Mbps) established
Port 2 LINK/Activity Status	Grey	No link, no activity
NS/ERR LED	Grey	---
MS/RUN LED	Green	---

At the bottom, there is a legend for the LED colors:

- Blue: Output Configured
- Yellow: Input ON
- Green: IO-Link Configured, but no device connected
- Light Green: IO-Link Configured, device connected
- Orange: Output Forced ON
- Purple: Output Forced OFF
- Red: IO pin is short-circuited or faulted
- Yellow-Green: Output ON

Figure 18 — Web Interface

**NOTE:**

- PCH Portal web page supports Microsoft Edge, Google Chrome and Mozilla Firefox browsers only.
- The GUI on web page is same as that on PC configuration tool.
- Please use latest version of browsers.

To configure PCH Portal enter Configuration mode by clicking on the “Configure mode” radio button and providing a valid password. The default password is “parker”. Configuration (write) access to PCH Portal is granted if it is not already in configuration mode.

While the PCH is in Configuration mode with, if the user connects the PLC, then the PLC does not gain control of the PCH until user releases the access from Configuration tool.

**NOTE:**

- Screens automatically refresh so inactivity is not applicable until web browser is closed and utility is closed.
- Once configuration mode is accessed by the PC Utility/Web server, the PLC cannot configure and actuate PCH Portal Outputs/Valves. PLC can only read inputs and device status from PCH Portal.

# Configuration Tool/Web Interface

The “PLC Mode” radio button is selected if PLC is connected to the PCH Portal. (refer to the upper right corner of the image below)

The screenshot shows the Parker PCH10MBAB0-P4 configuration tool web interface. At the top right, the "PLC Mode" radio button is selected. The interface includes a navigation menu with "STATUS", "CONFIGURATION", "FORCE MODE", "LOG", and "HELP".

**Status**

PCH10MBAB0-P4

Address	Valve Tag	Connect	State	Address	Valve Tag	Connect	State
0	EV0	OFF	■	16	EV16	OFF	■
1	EV1	OFF	■	17	EV17	OFF	■
2	EV2	OFF	■	18	EV18	OFF	■
3	EV3	OFF	■	19	EV19	OFF	■
4	EV4	OFF	■	20	EV20	OFF	■
5	EV5	OFF	■	21	EV21	OFF	■
6	EV6	OFF	■	22	EV22	OFF	■
7	EV7	OFF	■	23	EV23	OFF	■
8	EV8	OFF	■	24	EV24	OFF	■
9	EV9	OFF	■	25	EV25	OFF	■
10	EV10	OFF	■	26	EV26	OFF	■
11	EV11	OFF	■	27	EV27	OFF	■
12	EV12	OFF	■	28	EV28	OFF	■
13	EV13	OFF	■	29	EV29	OFF	■
14	EV14	OFF	■	30	EV30	OFF	■
15	EV15	OFF	■	31	EV31	OFF	■

**Device Information**

Device Name	PCH Portal
Protocol	Modbus TCP
IP Address	192.168.1.99
Bluetooth	OFF
DHCP	Disabled
Total Current Available	Logic 0.43 A Aux <12 A
Maximum Current	Logic 8 A Aux 12 A
Configuration Data Bytes	390
Bytes Produced	500
Bytes Consumed	492
Serial Number	ABCD1234

LED	Status	Value	Description
Aux Power	●	24.03 V	Connected and within Limit
Logic Power	●	24.79 V	Connected and within Limit
Bluetooth	●	-	OFF
Device Status	●	-	Normal

LED	Status	Description
Port 1 LINK/Activity Status	●	Activity (100 Mbps)
Port 2 LINK/Activity Status	●	No link, no activity
NS/ERR LED	●	---
MS/RUN LED	●	---

PLC Mode  Configure Mode

Output Configured     Input ON     IO-Link Configured, but no device connected     IO-Link Configured, device connected  
 Output Forced ON     Output Forced OFF     IO pin is short - circuited or faulted     Output ON

Device connected

Figure 19 — “PLC Mode” radio button selected

# Configuration Tool/Web Interface

## 5.1.1 Status Screen

The “Status” screen displays live status of the PCH Portal. All the device information like protocol, IP address etc. is displayed in the table on the right hand side. Status of all the LEDs are displayed in the table at the bottom. Digital Input, Digital Output and IO-Link pin status is displayed on the device image on the left hand side. Valve status is displayed in the table at the center.

**Parker** ● PLC Mode ○ Configure Mode

STATUS CONFIGURATION FORCE MODE LOG HELP

### Status

PCH10MBAB0-P4

Address	Valve Tag	Connect	State	Address	Valve Tag	Connect	State
0	EV0	OFF	●	16	EV16	OFF	●
1	EV1	OFF	●	17	EV17	OFF	●
2	EV2	OFF	●	18	EV18	OFF	●
3	EV3	OFF	●	19	EV19	OFF	●
4	EV4	OFF	●	20	EV20	OFF	●
5	EV5	OFF	●	21	EV21	OFF	●
6	EV6	OFF	●	22	EV22	OFF	●
7	EV7	OFF	●	23	EV23	OFF	●
8	EV8	OFF	●	24	EV24	OFF	●
9	EV9	OFF	●	25	EV25	OFF	●
10	EV10	OFF	●	26	EV26	OFF	●
11	EV11	OFF	●	27	EV27	OFF	●
12	EV12	OFF	●	28	EV28	OFF	●
13	EV13	OFF	●	29	EV29	OFF	●
14	EV14	OFF	●	30	EV30	OFF	●
15	EV15	OFF	●	31	EV31	OFF	●

### Device Information

Device Name	PCH Portal
Protocol	Modbus TCP
IP Address	192.168.1.99
Bluetooth	OFF
DHCP	Disabled
Total Current Available	Logic 0.27 A Aux <12 A
Maximum Current	Logic 8 A Aux 12 A
Configuration Data Bytes	390
Bytes Produced	500
Bytes Consumed	492
Serial Number	ABCD1234

LED	Status	Value	Description
Aux Power	●	24 V	Connected and within Limit
Logic Power	●	24.82 V	Connected and within Limit
Bluetooth	○	-	OFF
Device Status	●	-	Normal

LED	Status	Description
Port 1 LINK/Activity Status	○	No link, no activity
Port 2 LINK/Activity Status	○	No link, no activity
NS/ERR LED	○	---
MS/RUN LED	●	---

● Output Configured      ● Input ON      ○ IO-Link Configured, but no device connected      ● IO-Link Configured, device connected  
● Output Forced ON      ● Output Forced OFF      ● IO pin is short - circuited or faulted      ● Output ON

Device connected ●

Figure 20 — Status Screen

# Configuration Tool/Web Interface

## 5.1.2 Port Configuration Screen

The “Port Config” screen allows user to view or change the pin configuration of PCH Portal. User can make configuration changes from the pin images or from the “Port Configuration Detail” table.

Note: LED colours have different meanings between status and configuration screens.

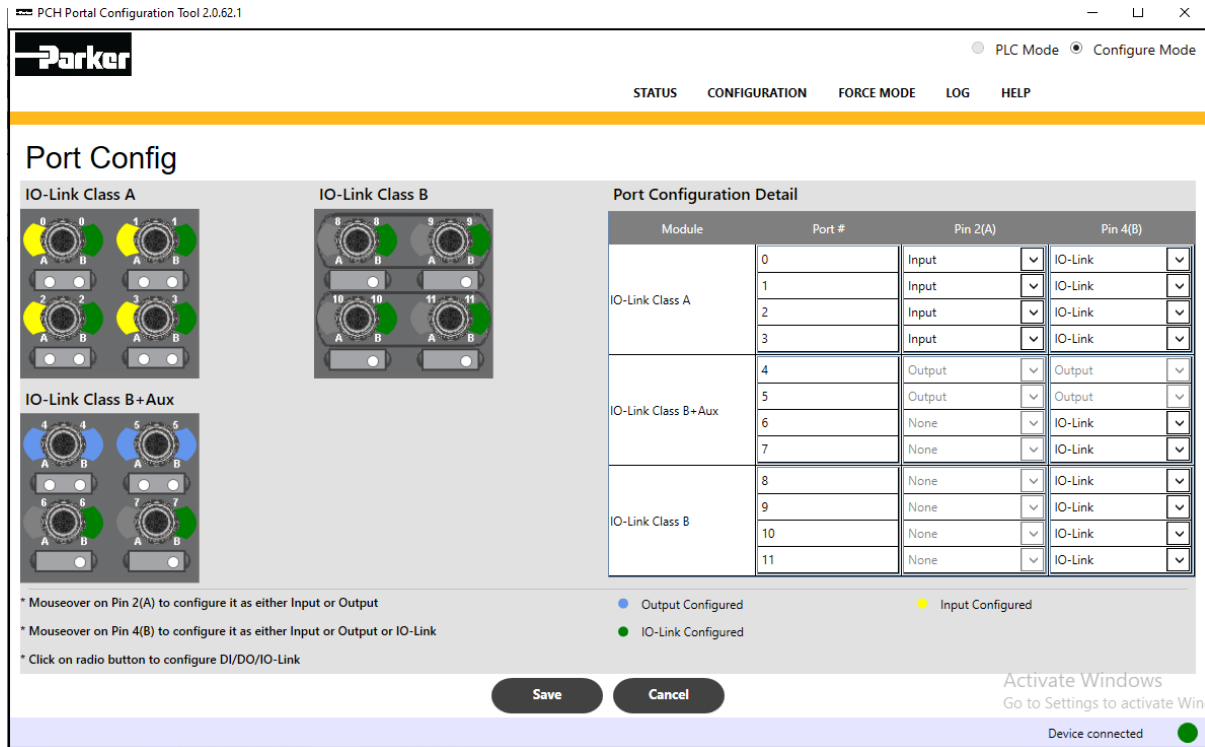

Figure 21 — Port Config screen

# Configuration Tool/Web Interface

## 5.1.3 Pin Config

The pin configuration can also be changed from the “Pin Config” tree structure. To see or change the configuration details or a particular Digital Input/Digital Output/IO-Link pin, select the appropriate respective radio button on the PCH Portal graphic in the “Port Config” screen.

The screenshot displays the Parker PCH Portal configuration tool in 'Configure Mode'. The main interface is divided into several sections:

- Status:** Shows a photograph of the PCH10MBAB0-P4 device and a table of digital inputs/outputs (EV0-EV15) with their addresses, valve tags, connection status, and states.
- Configuration:** A central menu with options for System Config, Port Config, Valve Config, Node Config, Pin Config (highlighted), and IODD Config.
- Device Information:** A table showing device details such as Name (PCH Portal), Protocol (Modbus TCP), and IP address (192.168.1.99).
- Port Configuration:** A tree view showing ports from Port0 to Port11, with Port0 expanded to show Pin 2(A) and Pin 4(B) configurations.
- LED Status:** Two tables showing the status of various LEDs like Aux Power, Logic Power, Bluetooth, Device Status, and Link/Activity LEDs.
- Legend:** A color-coded key for LED and pin status indicators.
- Footer:** A 'Device connected' indicator with a green dot.

Figure 22 — Pin Configuration Change

# Configuration Tool/Web Interface

## 5.1.4 Digital Input Config Sreen

User can see or change the below parameters on this screen:

- a. Description of Channel
- b. Digital Input Type
- c. Invert
- d. Debounce Time
- e. Cycle Warning Mode
- f. Cycle Count Type
- g. Upcounter cycle count notification limit/Downcounting preset to 0
- h. Cycle Reset.

The screenshot shows a web interface window titled "Digital Input" with a close button in the top right corner. The window contains several configuration fields:

- Description of Channel (Maximum of 20 characters):** A text input field containing "DI\_1".
- Module Position:** A numeric input field containing "1".
- Channel Number:** A numeric input field containing "0".
- Digital Input Type:** A dropdown menu with "PNP" selected.
- Invert:** A dropdown menu with "DISABLE" selected.
- Debounce Time (0-120 ms):** A numeric input field containing "0".
- Cycle Warning Mode:** A toggle switch that is currently turned off.
- Cycle Count:** A numeric input field containing "0".
- Cycle Count Type:** A dropdown menu with "UPCOUNTER" selected.
- Upcounter cycle count notification limit / Downcounting preset to 0:** A numeric input field containing "10000000".
- Cycle Reset:** A checkbox that is currently unchecked.

At the bottom of the configuration area, there are three icons with descriptions:

- An information icon (i) with the text "Mouseover on symbol for field description".
- A warning icon (!) with the text "Mouseover on symbol for warning description".
- A red square icon with the text "Mouseover on field to see error text for invalid input".

At the bottom of the window, there are three buttons: "Save", "Cancel", and "Refresh". On the far right, there is a partially visible button labeled "Activat" and "Go to Se".

Figure 23 — Digital Input Configuration Screen

# Configuration Tool/Web Interface

## 5.1.5 Digital Output Configuration Screen

- a. Description of Channel
- b. Fault Mode
- c. Cycle Warning Mode
- d. Cycle Count Type
- e. Upcounter cycle count notification limit/Downcounting preset to 0
- f. Cycle Reset

The screenshot shows a web interface window titled "Digital Output" with a close button in the top right corner. The interface contains several configuration fields:

- Description of Channel (Maximum of 20 characters):** A text input field containing "DO\_9".
- Module Position:** A text input field containing "2".
- Channel Number:** A text input field containing "8".
- Fault Mode:** A dropdown menu with "LASTGOOD" selected.
- Cycle Warning Mode:** A toggle switch that is currently turned off.
- Cycle Count:** A text input field containing "0".
- Cycle Count Type:** A dropdown menu with "UPCOUNTER" selected.
- Upcounter cycle count notification limit / Downcounting preset to 0:** A text input field containing "10000000".
- Cycle Reset:** A checkbox that is currently unchecked.

At the bottom of the configuration area, there are three icons with descriptions:

- An information icon (i) with the text "Mouseover on symbol for field description".
- A warning icon (!) with the text "Mouseover on symbol for warning description".
- A red square icon with the text "Mouseover on field to see error text for invalid input".

At the bottom of the window, there are three buttons: "Save", "Cancel", and "Refresh". In the bottom right corner, there is a partially visible "Activate" button and the text "Go to Se".

Figure 24 — Digital Output Configuration Screen

# Configuration Tool/Web Interface

## 5.1.6 IO-Link Port Configuration Screen

- The live data from the connected IO-Link slave device is displayed under the “Device Information” section.
- The data in the “Optional Device Information” section is fetched when “Get Info” button is pressed.
- User can change the “Data Storage”, “Inspection Level” and “Cycle Time” from this screen as long as it is in “Configuration Mode”.
- User can read/write Parameter data by entering the Index and Sub-Index in the “Parameter” section.
- User can see the cyclic input or can change the cyclic output from the “Process Data” section by selecting the “i” icon.
- The Parameter Content section displays the parameters and their respective data of the IO-Link slave device as long as the IODD file has been uploaded to the PCH Portal. Refer to 5.1.9 for IODD file management.
- “Read All” button reads all the parameter data from the connected IO-Link slave device and updates data into parameter content table.
- The “Data Storage” section at the bottom displays the “Device ID” and “Vendor ID” of the IO-Link slave device whose parameters have been uploaded on the current port.

**IO-Link Port Configuration** IO-Link Events

**Device Information**

Device ID: 401152  
Product Name: Parker Moduflex IO Link  
Product ID: P2M2HBVL12400A (Class A) | P2  
Vendor Name: Parker Hannifin  
Vendor ID: 271  
Serial Number: 4217-0-0038  
PD IN Length: 1 Bytes  
PD OUT Length: 3 Bytes  
Cycle Time: 8.0 ms  
Error Tag: No Error  
Port #: 3

**Optional Device Information**

Hardware rev: HW-V1.0  
Firmware rev: FW-V1.10  
Product Text: IOL V1.1.2 | Connection  
Application Tag: Parker  
Vendor Text: Pneumatic Division

**Process Data**

Input: 00  
Output: 00-00-00

**Parameter**

Data Storage  
 Inspection Level

Index(dec): 0    Sub Index(dec): 0    Data:     Hex     Dec     Char  
Data Size: 4 Bytes

Read     Write    **Apply**    **Clear**

**Parameter Content** (Name, Index(dec), Sub Index(dec), Data) **Read All**

Error with IO-Link device (refer to Error Tag)    **i** Mouseover on symbol for field description

**Save**    **Cancel**    **Refresh**

Figure 25 — IO Port Configuration Screen

# Configuration Tool/Web Interface

## 5.1.7 IO-Link Events Screen

Events related to IO-Link are displayed in the “IO-Link Events” screen of the respective IO-Link port. “The IO-Link Events” screen is accessed by selecting the “IO-Link Events” button as shown in Figure 26.” User has to refresh this screen to see new logs. User can export these logs in CSV format. User can also clear the logs as long as they are in “Configuration Mode”.

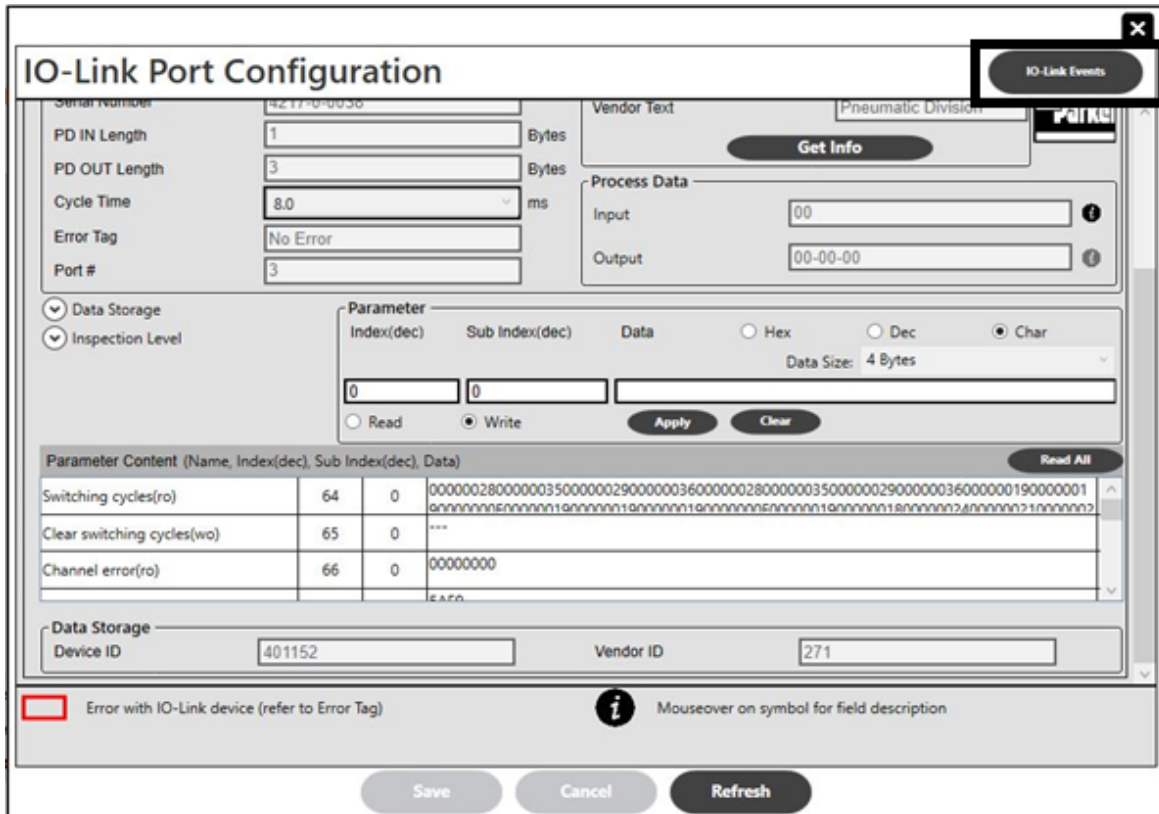

Figure 26 — Navigation to IO-Link Event Screen

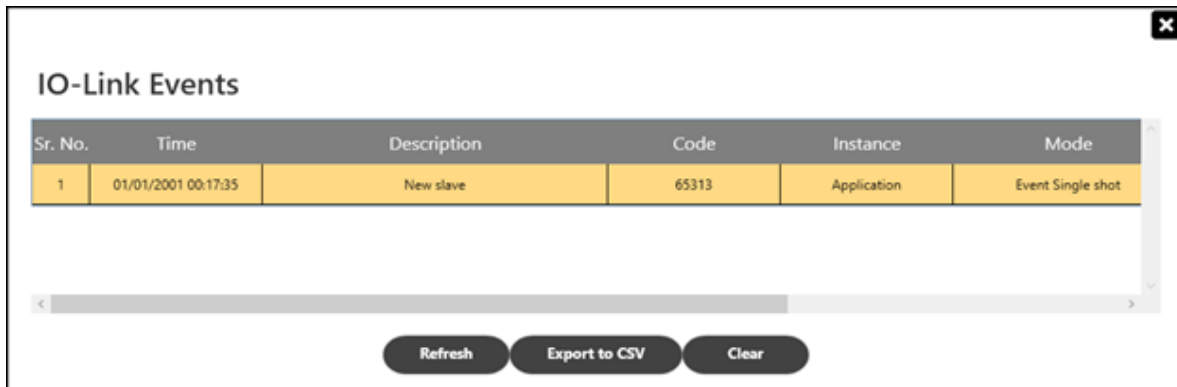

Figure 27 — IO-Link Events Screen

### NOTE:

- A maximum of 30 events are logged at a time.
- “Read All” button reads “Read only” and “Read Write” parameter data and updates into parameter content table as long as the IODD file has been uploaded to the PCH Portal. Refer to section 5.1.9 for IODD file management.

# Configuration Tool/Web Interface

## 5.1.8 Valve Configuration Screen

The “Valve Config” screen is used to change the configuration of any Valve. The following parameters of valves can be changed through Valve Config Screen:

- a. Valve Tag
- b. Fault Mode
- c. Cycle Warning mode
- d. Cycle Count Type
- e. Cycle Limit
- f. Cycle Reset

The screenshot shows the Parker Valve Config interface. At the top, there is a navigation bar with 'CONFIGURATION' selected. Below the navigation bar, the title 'Valve Config' is displayed. The main content area contains two tables of valve configurations. Each table has four columns: Address, Valve Tag, Fault Mode, and Cycle Warning. The first table lists valves from Address 0 to 15, and the second table lists valves from Address 16 to 31. All valves are currently set to 'LASTGOOD' for Fault Mode and have their Cycle Warning mode turned off. At the bottom of the screen, there are three buttons: 'Save', 'Cancel', and 'Refresh'. A status indicator at the bottom right shows 'Device connected' with a green dot.

Address	Valve Tag	Fault Mode	Cycle Warning
0	EV0	LASTGOOD	<input type="checkbox"/>
1	EV1	LASTGOOD	<input type="checkbox"/>
2	EV2	LASTGOOD	<input type="checkbox"/>
3	EV3	LASTGOOD	<input type="checkbox"/>
4	EV4	LASTGOOD	<input type="checkbox"/>
5	EV5	LASTGOOD	<input type="checkbox"/>
6	EV6	LASTGOOD	<input type="checkbox"/>
7	EV7	LASTGOOD	<input type="checkbox"/>
8	EV8	LASTGOOD	<input type="checkbox"/>
9	EV9	LASTGOOD	<input type="checkbox"/>
10	EV10	LASTGOOD	<input type="checkbox"/>
11	EV11	LASTGOOD	<input type="checkbox"/>
12	EV12	LASTGOOD	<input type="checkbox"/>
13	EV13	LASTGOOD	<input type="checkbox"/>
14	EV14	LASTGOOD	<input type="checkbox"/>
15	EV15	LASTGOOD	<input type="checkbox"/>

Address	Valve Tag	Fault Mode	Cycle Warning
16	EV16	LASTGOOD	<input type="checkbox"/>
17	EV17	LASTGOOD	<input type="checkbox"/>
18	EV18	LASTGOOD	<input type="checkbox"/>
19	EV19	LASTGOOD	<input type="checkbox"/>
20	EV20	LASTGOOD	<input type="checkbox"/>
21	EV21	LASTGOOD	<input type="checkbox"/>
22	EV22	LASTGOOD	<input type="checkbox"/>
23	EV23	LASTGOOD	<input type="checkbox"/>
24	EV24	LASTGOOD	<input type="checkbox"/>
25	EV25	LASTGOOD	<input type="checkbox"/>
26	EV26	LASTGOOD	<input type="checkbox"/>
27	EV27	LASTGOOD	<input type="checkbox"/>
28	EV28	LASTGOOD	<input type="checkbox"/>
29	EV29	LASTGOOD	<input type="checkbox"/>
30	EV30	LASTGOOD	<input type="checkbox"/>
31	EV31	LASTGOOD	<input type="checkbox"/>

Figure 28 — Valve Config Screen

# Configuration Tool/Web Interface

## 5.1.9 IODD Configuration Screen

The “IODD Config” screen is used to upload an IODD file to the PCH Portal IODD library in the device or delete an IODD file from PCH Portal IODD library. IODD files are loaded into the IODD library regardless of what IO-Link port they are, or will be, connected to.

The screenshot shows the Parker web interface in 'Configure Mode'. The main navigation bar includes 'STATUS', 'CONFIGURATION' (selected), 'FORCE MODE', 'LOG', and 'HELP'. A dropdown menu is open under 'CONFIGURATION', showing options: 'System Config', 'Port Config', 'Valve Config', 'Node Config', 'Pin Config', and 'IODD Config' (highlighted).

**Status Section:** Displays a photo of the PCH10MBAB0-P4 device and a table of valve configurations:

Address	Valve Tag	Connect	State	Address	Valve Tag	Connect	State
0	EV0	OFF	OFF	16	EV16	OFF	OFF
1	EV1	OFF	OFF	17	EV17	OFF	OFF
2	EV2	OFF	OFF	18	EV18	OFF	OFF
3	EV3	OFF	OFF	19	EV19	OFF	OFF
4	EV4	OFF	OFF	20	EV20	OFF	OFF
5	EV5	OFF	OFF	21	EV21	OFF	OFF
6	EV6	OFF	OFF	22	EV22	OFF	OFF
7	EV7	OFF	OFF	23	EV23	OFF	OFF
8	EV8	OFF	OFF	24	EV24	OFF	OFF
9	EV9	OFF	OFF	25	EV25	OFF	OFF
10	EV10	OFF	OFF	26	EV26	OFF	OFF
11	EV11	OFF	OFF	27	EV27	OFF	OFF
12	EV12	OFF	OFF	28	EV28	OFF	OFF
13	EV13	OFF	OFF	29	EV29	OFF	OFF
14	EV14	OFF	OFF	30	EV30	OFF	OFF
15	EV15	OFF	OFF	31	EV31	OFF	OFF

**Device Information Section:**

Device Name	PCH Portal
Protocol	Modbus TCP
IP Address	192.168.1.99
Bluetooth	OFF
DHCP	Disabled
Total Current Available	Logic 0.43 A Aux <12 A
Maximum Current	Logic 8 A Aux 12 A
Configuration Data Bytes	390
Bytes Produced	500
Bytes Consumed	492
Serial Number	ABCD1234

**LED Status Section:**

LED	Status	Value	Description
Aux Power	ON	24 V	Connected and within Limit
Logic Power	ON	24.79 V	Connected and within Limit
Bluetooth	OFF	-	OFF
Device Status	ON	-	Normal

**Port Activity Section:**

LED	Status	Description
Port 1 LINK/Activity Status	OFF	No link, no activity
Port 2 LINK/Activity Status	OFF	No link, no activity
NS/ERR LED	OFF	---
MS/RUN LED	ON	---

**Legend:**

- Output Configured (Blue dot)
- Output Forced ON (Orange dot)
- Input ON (Yellow dot)
- Output Forced OFF (Purple dot)
- IO-Link Configured, but no device connected (Green dot)
- IO pin is short - circuited or faulted (Red dot)
- IO-Link Configured, device connected (Dark Green dot)
- Output ON (Yellow dot)

Device connected (Green dot)

Figure 29 — Navigation to IODD Configuration screen

The screenshot shows the Parker web interface in 'Configure Mode'. The main navigation bar includes 'STATUS', 'CONFIGURATION' (selected), 'FORCE MODE', 'LOG', and 'HELP'.

**IODD Config Section:**

Form fields for entering device information:

- Device ID:
- Vendor Name:
- File Name:
- File Size:  Bytes
- IODD Filename:

Buttons: , ,

**IODD File Library Table:**

Vendor ID	Device ID	File Name
271	401152	Parker-92M2H-BVL12400A-ClassA92M2H-BVL12400B-ClassB-20180731-IODD1.1.xml
888	393730	Balkhoff-8ISM4000450020754-20190218-IODD1.1.xml

Figure 30 — IODD Config

**NOTE:**

- After uploading an IODD file, device image and vendor logo gets updated automatically but in web interface user must upload the device image and vendor logo manually after uploading the IODD file.
- User does not need configuration access to upload/delete IODD files.
- User can upload maximum 12 IODD files into the PCH portal.

# Configuration Tool/Web Interface

## 5.1.10 Force Mode Screen

To actuate DO/Valves of PCH Portal, enter Force mode by clicking on “Force mode” tab, then click on the slider button and provide valid password. The default password is “parker”. Access to PCH Portal force mode is granted if it is not already in force mode. User has to click on the radio buttons or on the Valve’s “Connect” column to actuate the Digital Outputs and Valves respectively.

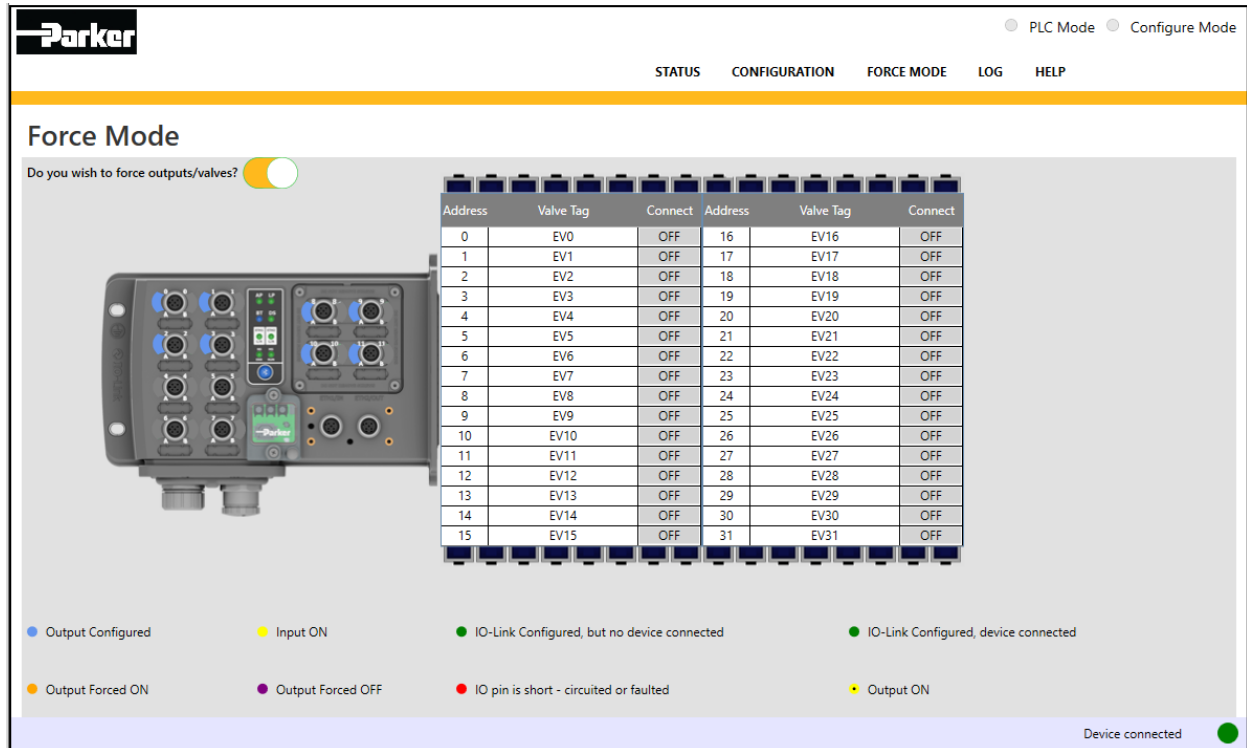

Figure 31 — Force Mode

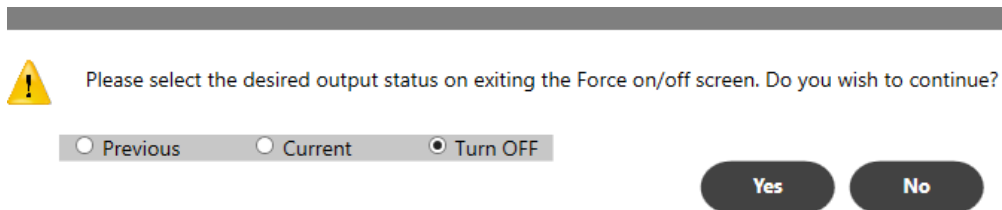

Figure 32 — Force on/off screen

On exiting the Force ON/OFF Screen, the user needs to select either Previous, Current, or Turn OFF option, which impacts Values and Digital Outputs.

## 5.1.11 Help Screen

User can click on the “HELP” tab to open the detailed GUI Help manual document.

# Configuration Tool/Web Interface

## 5.1.12 System Configuration Screen

The “System Configuration” screen displays the system wide parameters such as date, time, network configuration addresses, MAC address, System ON Time, and Bluetooth configuration settings. Some of these parameters are user configurable in configuration mode. QuickConnect is not applicable for Modbus and hence it is non-configurable.

QuickConnect Mode for Modbus TCP: OFF

**Parker** ● PLC Mode ● **Configure Mode**

STATUS CONFIGURATION FORCE MODE LOG HELP

---

### System Configuration

Quick Connect Mode	OFF
Bluetooth	<input type="checkbox"/>
Bluetooth On Timer (1-20)	10 mins
System Up Time/ Hour Clock	1 hrs
Set System Date	08-19-2020
Set System Time	04:00:21 PM
Web Version	7.46
Firmware Package Version	05.62B

### Network Configuration

IP Address	192.168.1.88
Subnet Mask	255.255.255.0
Default Gateway	192.168.1.1
DHCP	Disabled
MAC Address	00-30-11-1D-9E-3A

**Save** **Cancel**

Device connected ●

**Figure 33** — System Configuration

# Configuration Tool/Web Interface

## 5.1.13 Node Configuration Screen

The “Node Configuration” page provides the capability to save the configuration of the PCH device to connected Windows PC, as well as to load the saved configuration from PC to PCH device. It also provides the option to restore the PCH device to its factory default settings.

**NOTE:** In Restore to Factory Default option, the PCH Portal device data will be cleared. It takes around 15 seconds to perform this operation. Restore in Progress” is indicated via blinking cyan DS LED.

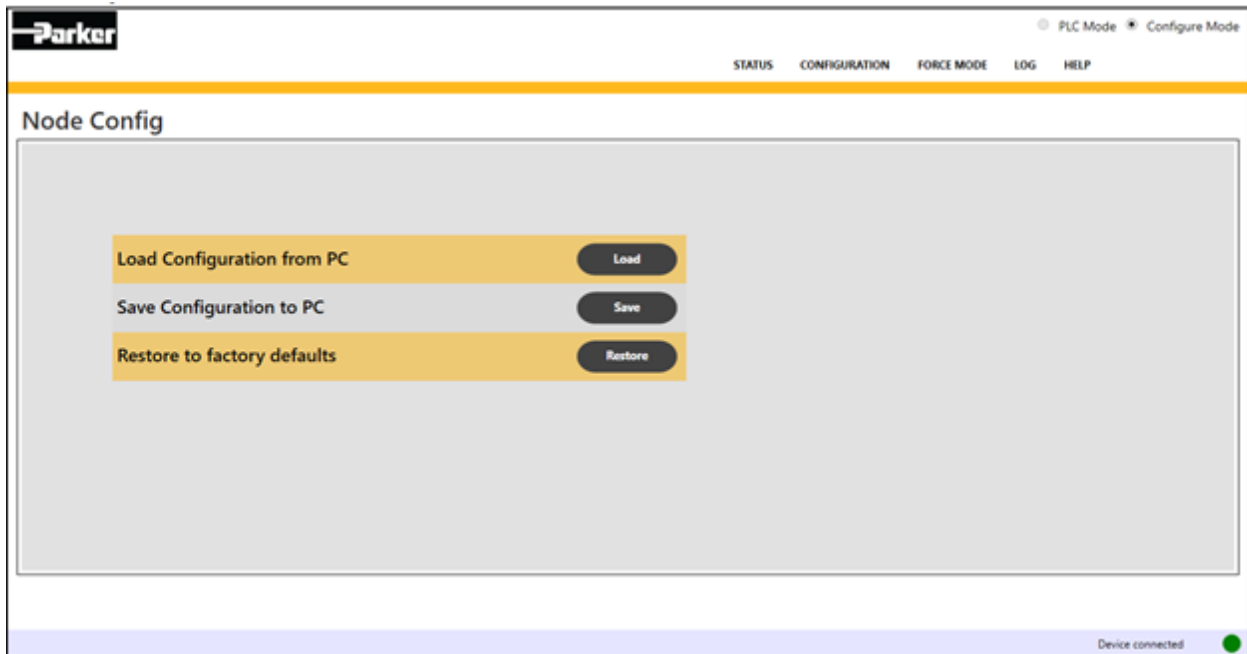

Figure 34 — Node Config

# Configuration Tool/Web Interface

## 5.1.14 Logs Screen

The “LOGS” tab displays three options; “Warnings”, “Events”, and “Errors”. All the events provide time/date stamp details as well as module information. It also provides the user action required to recover from the Error and Events.

**NOTE:** A maximum of 40 events are logged at a time.

**Errors**

Index	Date	Time	Module	Module Position	Description	Remarks
4	08/05/20	11:05:42	MS/Co-Proc	---	Database Initialization Failed	User can perform following options Option 1: Configuration download through utility or PLC Option 2: Replace the Device
5	07/31/20	14:27:15	MS/Co-Proc	---	Database Initialization Failed	User can perform following options Option 1: Configuration download through utility or PLC Option 2: Replace the Device
6	07/31/20	14:23:12	MS/Co-Proc	---	Database Initialization Failed	User can perform following options Option 1: Configuration download through utility or PLC Option 2: Replace the Device
7	07/31/20	14:13:44	MS/Co-Proc	---	Database Initialization Failed	User can perform following options Option 1: Configuration download through utility or PLC Option 2: Replace the Device
8	07/31/20	13:45:23	MS/Co-Proc	---	Database Initialization Failed	User can perform following options Option 1: Configuration download through utility or PLC Option 2: Replace the Device
9	07/31/20	13:35:43	MS/Co-Proc	---	Database Initialization Failed	User can perform following options Option 1: Configuration download through utility or PLC Option 2: Replace the Device
10	07/31/20	13:07:36	MS/Co-Proc	---	Database Initialization Failed	User can perform following options Option 1: Configuration download through utility or PLC Option 2: Replace the Device

\* Module Positions: CPR - Co-Proc VAL - Valve BLT - Bluetooth N/W - Network

Export to CSV Refresh

Device connected

Figure 35 — Error Screen

**Events**

Index	Date	Time	Module	Module Position	Description	Remarks
1	08/17/20	12:03:14	MS/Co-Proc	---	Configuration Updated	No Action Required
2	08/17/20	12:03:14	MS/Co-Proc	---	Device Started	No Action Required
3	08/17/20	12:03:14	MS/Co-Proc	---	Device Shutdown	No Action Required
4	08/17/20	12:03:14	MS/Co-Proc	---	Firmware Upgrade Completed	No Action Required
5	08/17/20	11:54:01	MS/Co-Proc	---	Firmware Upgrade Started	No Action Required
6	08/17/20	11:53:43	MS/Co-Proc	---	Configuration Updated	No Action Required
7	08/17/20	11:53:43	MS/Co-Proc	---	Device Started	No Action Required
8	08/14/20	19:53:21	MS/Co-Proc	---	Device Shutdown	No Action Required
9	08/14/20	19:13:20	MS/Co-Proc	---	Configuration Updated	No Action Required
10	08/14/20	19:13:20	MS/Co-Proc	---	Device Started	No Action Required

\* Module Positions: CPR - Co-Proc VAL - Valve BLT - Bluetooth N/W - Network

Export to CSV Refresh

Device connected

Figure 36 — Events Screen

# Configuration Tool/Web Interface

**Parker** ● PLC Mode ● **Configure Mode**

STATUS CONFIGURATION FORCE MODE LOG HELP

### Warnings

10

Index	Date	Time	Module	Module Position	Description	Remarks
1	10/29/20	16:36:19	IO/IO-Link	001	DI 0 Cycle Count Limit Reached	User can perform following options Option 1: Need to replace corresponding DI - Sensor and Reset the cycle count
2	10/29/20	16:06:38	IO/IO-Link	001	DO 1 Cycle Count Limit Reached	User can perform following options Option 1: Need to replace corresponding DO - Actuator and Reset the cycle count
3	10/29/20	16:06:35	Valve	---	Valve 0 Cycle Count Limit Reached	User can perform following options Option 1: Need to replace corresponding Valve and Reset the cycle count
4	10/29/20	16:03:44	Valve	---	Valve 0 Cycle Count Limit Reached	User can perform following options Option 1: Need to replace corresponding Valve and Reset the cycle count
5	10/29/20	16:03:44	IO/IO-Link	001	DO 1 Cycle Count Limit Reached	User can perform following options Option 1: Need to replace corresponding DO - Actuator and Reset the cycle count
6	10/29/20	15:50:18	Logic Voltage	---	Low Voltage between 19.40V to 20.39V - [19.68V]	User needs to check the Logic voltage and take appropriate action to correct it. Once the Logic voltage sets to the normal working range device will reset the warning indications and log an event.
7	10/29/20	15:50:15	Auxiliary Voltage	---	Low Voltage between 19.40V to 20.39V - [20.28V]	User needs to check the Auxiliary voltage and take appropriate action to correct it. Once the Auxiliary voltage sets to the normal working range device will reset the warning indications to normal and log an event.
8	10/29/20	15:50:15	Logic Voltage	---	Low Voltage between 19.40V to 20.39V - [20.22V]	User needs to check the Logic voltage and take appropriate action to correct it. Once the Logic voltage sets to the normal working range device will reset the warning indications and log an event.
9	10/29/20	15:19:46	IO/IO-Link	003	IO-Link 10 - Validation Failure	User can perform following options Option 1: Need to replace IO-Link sensor with valid Vendor ID, Device ID and/or Serial

\* Module Positions:- CPR - Co-Proc VAL - Valve BLT - Bluetooth N/W - Network

< 1 of 1 >

Export to CSV Refresh

Device connected ●

**Figure 37 — Warning Screen**

## 5.2 Bluetooth Mobile Application

The Bluetooth mobile application is also available to view status and configure the PCH Portal. This Bluetooth application is available for Android and iOS mobile devices and tablets. Please download the application from app store and install to mobile device to get connected with PCH Portal over Bluetooth interface.

Please ensure Bluetooth communication of PCH Portal is turned ON before connecting. It can be turned on via configuration tool/web interface or by pressing Bluetooth button (and holding for more than 3 seconds) on Bluetooth module. Bluetooth LED flashes and turns solid when connected to the phone or tablet.

## CHAPTER - 6 **Troubleshooting**

# Troubleshooting

## 6.1 Troubleshooting

**Table 56 — Troubleshooting Information**

Description	Area/Module	Category	Event Log Message	Process Input Status Bits	User Actions
			Format: Date   Time   Module   Module Position   Description		
<b>Auxiliary Power - Low Voltage below 19.40V (Hysteresis 19.60V)</b>  Note: Under voltage cut-off:14.70V Under voltage cut-off recovery:15.70V	Auxiliary Voltage	Error	MM-DD-YY   HRS: MIN:SEC   Auxiliary Voltage   ---   Low Voltage below 19.40V - [<Actual Voltage>V]	Aux Voltage bit = 1 Error bit = 1	# User needs to check the Auxiliary voltage and take appropriate action to correct it. Once the Auxiliary voltage sets to the normal working range, the device resets the error indications to normal and log an event.
<b>Auxiliary Power - Low Voltage between 19.40V and 20.40V (Hysteresis 19.60V to 20.60V)</b>		Warning	MM-DD-YY   HRS: MIN:SEC   Auxiliary Voltage   ---   Low Voltage between 19.40V to 20.39V - [<Actual Voltage>V]	Aux Voltage bit = 1 Warning bit = 1	# User needs to check the Auxiliary voltage and take appropriate action to correct it. Once the Auxiliary voltage sets to the normal working range, the device resets the warning indications to normal and log an event.
<b>Auxiliary Power - Voltage between 20.40V and 28.80V (Hysteresis 20.60V to 28.60V)</b>		Event	MM-DD-YY   HRS: MIN:SEC   Auxiliary Voltage   ---   Normal Voltage between 20.40V to 28.80V - [<Actual Voltage>V]	NA	# No Action Required
<b>Auxiliary Power - High Voltage between 28.80V and 29.50V (Hysteresis 28.60V to 29.30V)</b>		Warning	MM-DD-YY   HRS: MIN:SEC   Auxiliary Voltage   ---   High Voltage between 28.81V to 29.50V - [<Actual Voltage>V]	Aux Voltage bit = 1 Warning bit = 1	# User needs to check the Auxiliary voltage and take appropriate action to correct it. Once the Auxiliary voltage sets to the normal working range, the device resets the error indications to normal and log an event.
<b>Auxiliary Power - High Voltage above 29.50V (Hysteresis 29.30V)</b>  Note: Overvoltage cut-off: 30.00 V Overvoltage cut-off recovery: 29.50V		Error	MM-DD-YY   HRS: MIN:SEC   Auxiliary Voltage   ---   High Voltage above 29.50V - [<Actual Voltage>V]	Aux Voltage bit = 1 Error bit = 1	# User needs to check the Auxiliary voltage and take appropriate action to correct it. Once the Auxiliary voltage sets to the normal working range, the device resets the error indications to normal and log an event.
<b>Logic Voltage below ~16.00V &lt;Shutdown&gt;</b>  Note: This event is not logged, only the indicators are mentioned wherever applicable  Note: Under voltage cut-off:14.70V Under voltage cut-off recovery:15.70V	Logic Voltage	---	---	NA	# Power is below min limits; unit does not power ON until the voltage is above min limits.
<b>Logic Power - Low Voltage between below 19.40V (Hysteresis 19.60V).</b>		Error	MM-DD-YY   HRS: MIN:SEC   Logic Voltage   ---   Low Voltage below 19.40V - [<Actual Voltage>V]	Logic Voltage bit = 1 Error bit = 1	# User needs to check the Logic voltage and take appropriate action to correct it. Once the Logic voltage sets to normal working range, the device resets the error indications to normal and log an event.

# Troubleshooting

Description	Area/Module	Category	Event Log Message	Process Input Status Bits	User Actions
			Format: Date   Time   Module   Module Position   Description		
<b>Logic Power - Low Voltage between 19.40V and 20.40V (Hysteresis 19.60V to 20.60V)</b>	Logic Voltage	Warning	MM-DD-YY   HRS: MIN:SEC   Logic Voltage   ---   Low Voltage between 19.40V to 20.39V - [<Actual Voltage>V]	Logic Voltage bit = 1 Warning bit = 1	# User needs to check the Logic voltage and take appropriate action to correct it. Once the Logic voltage sets to the normal working range, device resets the warning indications and log an event.
<b>Logic Power - Voltage between 20.40V and 28.80V (Hysteresis 20.60V to 28.60V)</b>		Event	MM-DD-YY   HRS: MIN:SEC   Logic Voltage   ---   Normal Voltage between 20.40V to 28.80V - [<Actual Voltage>V]	NA	# No Action Required
<b>Logic Power - High Voltage above 28.80V (Hysteresis 28.60V)</b>		Warning	MM-DD-YY   HRS: MIN:SEC   Logic Voltage   ---   High Voltage above 28.80V - [<Actual Voltage>V]	Logic Voltage bit = 1 Warning bit = 1	# User needs to check the Logic voltage and take appropriate action to correct it. Once the Logic voltage is sets to the normal working range, the device resets the warning indications and log an event.
<b>Logic Voltage above ~29.50V &lt;Shutdown&gt;</b>  Note: This event is not logged, only indicators are mentioned wherever applicable  Note: Overvoltage cut-off: 30.00 V Overvoltage cut-off recovery: 29.50V		---	---	NA	# Power is above max limits; the device does not power on until logic voltage is below max limits
<b>Model Specification Mismatch</b>  Note: For this event no information is updated in any Data map for PLC. It is notified only through Device/Configuration Tool Indicators and Message Logging.	MS/Co-Proc	Error	MM-DD-YY   HRS:MIN:SEC   MS/Co-Proc   <Module Position>   Model Specification Mismatch  where <Module Position> for IO Modules is indicated as 001 - Module Position 1 002 - Module Position 2 003 - Module Position 3 and Other modules are indicated as N/W - Network Module (this indicates Protocol Mismatch) VAL - Valve Module	NA	# User can perform the following options: Option 1: Power Cycle the Device. Option 2: Upgrade Firmware of the Device. Option 3: Replace the IO Module as per configured Model Specification. Option 4: Replace the Device.
<b>Device in Bootloader</b>  This occurs when device fails to jump from Boot mode to Application mode due to Application image corruption  Note: This event is not logged, only indicators are mentioned wherever applicable.		Error	---	NA	# User can perform the following options: Option 1: Upgrade Firmware of the Device Option 2: Replace the Device

# Troubleshooting

Description	Area/Module	Category	Event Log Message	Process Input Status Bits	User Actions
			Format: Date   Time   Module   Module Position   Description		
<b>Device Started</b>	MS/Co-Proc	Event	MM-DD-YY   HRS: MIN:SEC   MS/Co-Proc   - --   Device Started	NA	#No Action Required
<b>Backplane Initialization Failed</b>		Error	MM-DD-YY   HRS: MIN:SEC   MS/Co-Proc   ---   Backplane Initialization Failed	MS/CoProc bit = 1 Error bit = 1	# User can perform the following options: Option 1: Power Cycle the Device Option 2: Upgrade Firmware of the Device (i.e., to upgrade I/O module firmware) Option 3: Replace the Device
<b>B40 Initialization Failed</b>  Note: For this event, no information is updated in any Data map for PLC. It is notified only through Device/Configuration Tool Indicators and Message Logging.		Error	MM-DD-YY   HRS: MIN:SEC   MS/Co-Proc   ---   N/W Module Initialization Failed	NA	# User can perform the following options: Option 1: Power Cycle the Device Option 2: Upgrade Firmware of N/W module through FTP Option 3: Replace the Device
<b>Database Initialization Failed</b>		Error	MM-DD-YY   HRS: MIN:SEC   MS/Co-Proc   ---   Database Initialization Failed	MS/CoProc bit = 1 Error bit = 1	# User can perform the following options: Option 1: Configuration download through utility or PLC Option 2: Replace the Device
<b>Device Shutdown</b>		Event	MM-DD-YY   HRS: MIN:SEC   MS/Co-Proc   ---   Device Shutdown	NA	# No Action Required
<b>Backplane Communication Break - &lt;Warning&gt;</b>		Warning	MM-DD-YY   HRS: MIN:SEC   MS/Co-Proc   ---   Backplane Communication Break	MS/CoProc bit = 1 Warning bit = 1	# User can perform the following option: Option 1: Eliminate the Noise Source
<b>Backplane Communication Break - &lt;Fault&gt;</b>		Error	MM-DD-YY   HRS: MIN:SEC   MS/Co-Proc   ---   Backplane Communication Break	MS/CoProc bit = 1 Error bit = 1	# User can perform the following options: Option 1: Eliminate the Noise Source Option 2: Power Cycle the Device Option 3: Upgrade Firmware of the Device Option 4: Replace the Device
<b>Backplane Communication Normal</b>		Event	MM-DD-YY   HRS: MIN:SEC   MS/Co-Proc   ---   Backplane Communication Normal	NA	# No Action Required
<b>Configuration Updated</b>  Note: This event occurs on any configuration change request from PCH Config Tool or through PLC		Event	MM-DD-YY   HRS: MIN:SEC   MS/Co-Proc   ---   Configuration Updated	NA	# No Action Required

# Troubleshooting

Description	Area/Module	Category	Event Log Message	Process Input Status Bits	User Actions
			Format: Date   Time   Module   Module Position   Description		
<b>Firmware Upgrade Started</b>  Note: In Application Mode this event is logged inclusive of Co-Proc Firmware Upgrade. In Boot Loader mode this event is logged excluding Co-Proc Firmware Upgrade since it is done through Boot Loader.	MS/Co-Proc	Event	MM-DD-YY   HRS: MIN:SEC   MS/Co-Proc   ---   Firmware Upgrade Started	NA	# No Action Required
<b>Firmware Upgrade Completed</b>		Event	MM-DD-YY   HRS: MIN:SEC   MS/Co-Proc   ---   Firmware Upgrade Completed	NA	# No Action Required
<b>Firmware Upgrade Failed</b>  Note: This event is limited to failure of IO-Module, Valve, Bluetooth and B40 firmware upgrade only, Co-proc firmware upgrade is excluded from this event since it's firmware upgrade is done through Boot Loader.		Error	MM-DD-YY   HRS: MIN:SEC   MS/Co-Proc   <Module Position>   Firmware Upgrade Failed  where <Module Position> for IO Modules is indicated as 001 - Module Position. 1 002 - Module Position. 2 003 - Module Position. 3 and <Module Position> for Other modules it is indicated as VAL - Valve Module BLT - Bluetooth Module N/W - Network Module	NA	# User can perform the following options: Option 1: Power Cycle the Device Option 2: Upgrade Firmware of the Device Option 3: Replace the Device
<b>Watchdog Expired (for Count &gt; 1 and &lt; 5)</b>  Note: In case of Remote modules (i.e., Valve and I/Os) this event can only be logged if event notifying logic of these modules to Co-Proc is not hanged.		Warning	MM-DD-YY   HRS: MIN:SEC   MS/Co-Proc   <Module Position>   Watch Dog Expired  where <Module Position> for IO Modules is indicated as 001 - Module Position. 1 002 - Module Position. 2 003 - Module Position. 3 and <Module Position> for Other modules it is indicated as CPR- Co-Proc Module VAL - Valve Module	MS/CoProc bit = 1 Warning bit = 1	# User can perform the following options: Option 1: Power Cycle the Device Option 2: Upgrade Firmware of specified module
<b>Watchdog Expired (for Count &gt;= 5)</b>  Note: In case of Remote modules (i.e., Valve and I/Os) this event can only be logged if event notifying logic of these modules to Co-Proc is not hanged.		Error	MM-DD-YY   HRS: MIN:SEC   MS/Co-Proc   <Module Position>   Watch Dog Expired  where <Module Position> for IO Modules is indicated as 001 - Module Position. 1 002 - Module Position. 2 003 - Module Position. 3 and <Module Position> for Other modules it is indicated as CPR- Co-Proc Module VAL - Valve Module	MS/CoProc bit = 1 Error bit = 1	# User can perform the following options: Option 1: Power Cycle the Device Option 2: Upgrade Firmware of specified module Option 3: Replace the Device

# Troubleshooting

Description	Area/Module	Category	Event Log Message	Process Input Status Bits	User Actions
			Format: Date   Time   Module   Module Position   Description		
<b>SPI Communication - B40 &lt;Warning&gt;</b>  Note: For this event, no information is updated in any Data map for PLC. It is notified only through Device/Configuration Tool Indicators and Message Logging.	MS/Co-Proc	Warning	MM-DD-YY   HRS: MIN:SEC   MS/Co-proc   ---   N/W Module - SPI Communication Break	NA	# User can perform the following options: Option 1: Restart the device Option 2: Upgrade Firmware of N/W through FTP Option 3: Replace the Device
<b>SPI Communication - B40 Normal</b>		Event	MM-DD-YY   HRS: MIN:SEC   MS/Co-proc   ---   N/W Module - SPI Communication Normal	NA	# No Action Required
<b>RTC VBAT not available</b>		Warning	MM-DD-YY   HRS: MIN:SEC   MS/Co-proc   ---   RTC VBAT not available	NA	# User can perform the following options: Option 1: Power Cycle the Device Option 2: Insert/Replace the RTC Battery Option 3: Replace the Device
<b>Invalid Configuration from PLC</b>  Note: For this event, no information is updated in any Data map for PLC. It is notified only through Device/Configuration Tool Indicators and Message Logging.		Warning	MM-DD-YY   HRS: MIN:SEC   MS/Co-proc   ---   Invalid Configuration from PLC	NA	# User can perform the following options: Option 1: Set correct configuration through PLC
<b>Auxiliary Current - Current till 12 Amps</b>	Auxiliary Current	Event	MM-DD-YY   HRS: MIN:SEC   Auxiliary Current   ---   Normal Auxiliary Current till 12Amps	NA	# No Action Required
<b>Auxiliary Current - Current above 12 Amps</b>  Note: - HW Cut-Off is at 12.7 Amps		Error	MM-DD-YY   HRS: MIN:SEC   Auxiliary Current   ---   High Auxiliary Current above 12Amps	Aux Current bit = 1 Error bit = 1	# User can perform the following options: Option 1: Power Cycle the Device Option 2: Replace the Device
<b>Logic Current - Current till 7.5 Amps</b>	Logic Current	Event	MM-DD-YY   HRS: MIN:SEC   Logic Current   ---   Normal Logic Current till 7.5Amps - [<Actual Current>Amps]	NA	# No Action Required
<b>Logic Current - Current between 7.5 Amps to 8 Amps</b>		Warning	MM-DD-YY   HRS: MIN:SEC   Logic Current   ---   High Logic Current between 7.5Amps to 8Amps - [<Actual Current>Amps]	Logic Current bit = 1 Warning bit = 1	# User can perform the following options: Option 1: Power Cycle the Device
<b>Logic Current - Current above 8 Amps</b>		Error	MM-DD-YY   HRS: MIN:SEC   Logic Current   ---   High Logic Current above 8Amps - [<Actual Current>Amps]	Logic Current bit = 1 Error bit = 1	# User can perform the following options: Option 1: Power Cycle the Device Option 2: Replace the Device

# Troubleshooting

Description	Area/Module	Category	Event Log Message	Process Input Status Bits	User Actions
			Format: Date   Time   Module   Module Position   Description		
Temperature till 75 °C	Temperature	Event	MM-DD-YY   HRS: MIN:SEC   Temperature Warning   ---   Normal Temperature till 75 °C - [<Actual Temperature>°C]	NA	# No Action Required
Temperature between 75 °C to 80 °C		Warning	MM-DD-YY   HRS: MIN:SEC   Temperature Warning   ---   High Temperature between 75 °C to 80 °C - [<Actual Temperature>°C]	Temperature Warning bit = 1 Warning bit = 1	# User can perform the following options: Option 1: Eliminate the Increasing Temperature Source Option 2: Power Cycle the Device
Temperature above 80 °C		Error	MM-DD-YY   HRS: MIN:SEC   Temperature Warning   ---   High Temperature above 80 °C - [<Actual Temperature>°C]	Temperature Warning bit = 1 Error bit = 1	# User can perform the following options: Option 1: Eliminate the Increasing Temperature Source Option 2: Power Cycle the Device Option 3: Replace the Device
Cycle Count Limit Reached	Valve	Warning	MM-DD-YY   HRS: MIN:SEC   Valve   ---   Valve <Valve No> Cycle Count Limit Reached  where <Valve No> varies from 0 to 31	Target Count bit = 1 Warning bit = 1	# User can perform the following options: Option 1: Need to replace corresponding Valve and reset cycle count (Acyclic Data Map - B22.0 to B25.7)  Note: The corresponding bits are set for 2 seconds
Short Circuit		Error	MM-DD-YY   HRS: MIN:SEC   Valve   ---   Valve <Valve No> in Fault State  where <Valve No> varies from 0 to 31	Valve bit = 1 Error bit = 1 VF00 - VF31 bit = 1 (Valve fault status) w.r.t corresponding valve	# User can perform the following options: Option 1: Need to remove short circuit by replacing Valve
SPI Communication/ Auxiliary Power Supply - Valve Driver <Warning>		Warning	MM-DD-YY   HRS: MIN:SEC   Valve   ---   Valve Driver <Valve Driver No.> - SPI Communication Break/ Auxiliary Supply Fault  where <Valve Driver No> varies from 1 to 4	Valve bit = 1 Warning bit = 1	# User can perform the following options: Option 1: Check Auxiliary Power Supply Option 2: Eliminate the Noise Source
EEPROM Corruption		Error	MM-DD-YY   HRS: MIN:SEC   Valve   ---   EEPROM Corrupted	Valve bit = 1 Error bit = 1	# User can perform the following options: Option 1: Power Cycle the Device Option 2: Replace the Device
SPI Communication/ Auxiliary Power Supply - Valve Driver <Fault>		Error	MM-DD-YY   HRS: MIN:SEC   Valve   ---   Valve Driver <Valve Driver No.> - SPI Communication Break/ Auxiliary Supply Fault  where <Valve Driver No> varies from 1 to 4	Valve bit = 1 Error bit = 1	# User can perform the following options: Option 1: Check Auxiliary Power Supply Option 2: Eliminate Noise Source Option 3: Power Cycle the Device Option 4: Replace the Device

# Troubleshooting

Description	Area/Module	Category	Event Log Message	Process Input Status Bits	User Actions
			Format: Date   Time   Module   Module Position   Description		
<b>I2C Communication - EEPROM &lt;Fault&gt;</b>	Valve	Error	MM-DD-YY   HRS: MIN:SEC   Valve   ---   EEPROM - I2C Communication Break	Valve bit = 1 Error bit = 1	# User can perform the following options: Option 1: Power Cycle the Device Option 2: Replace the Device
<b>Cycle Count Limit Reached - DI</b>	IO/IO-Link	Warning	MM-DD-YY   HRS: MIN:SEC   IO/IO-Link   < Module Position>   DI <Channel No> Cycle Count Limit Reached  where <Channel No.> varies from 0 to 23	Target Count bit = 1 Warning bit = 1	# User can perform the following options: Option 1: Need to replace corresponding DI - Sensor and Reset the cycle count (Acyclic Data Map - B49.0 to B51.7)  Note: The corresponding bits are set for 2 seconds.
<b>Cycle Count Limit Reached - DO</b>		Warning	MM-DD-YY   HRS: MIN:SEC   IO/IO-Link   <Module Position>   DO <Channel No> Cycle Count Limit Reached  where <Channel No.> varies from 0 to 23	Target Count bit = 1 Warning bit = 1	# User can perform the following options: Option 1: Need to replace corresponding DO - Actuator and Reset the cycle count (Acyclic Data Map - B69.0 to B71.7)  Note: The corresponding bits are set for 2 seconds.
<b>Short to GND or Overload at Pin 2 and Pin 4 of M12</b>		Error	MM-DD-YY   HRS: MIN:SEC   IO/IO-Link   <Module Position>   Over Current at Channel No. <Channel No>  where <Channel No.> varies from 0 to 23	IO/IO-Link bit = 1 Error bit = 1 OC bit = 1 OC 1,2 or 3 bit = 1 overcurrent w.r.t corresponding I/O module	# User can perform the following option: Option 1: Need to remove short circuit and Power Cycle the Device.
<b>Electronic fuse trip at Pin 1 of M12 due thermal /current overload/ Short Circuit</b>		Error	MM-DD-YY   HRS: MIN:SEC   IO/IO-Link   <Module Position>   Logic Supply Overload	IO/IO-Link bit = 1 FS = 1 Error bit = 1	# User can perform the following option: Option 1: Need to remove short circuit
<b>IO Module configuration and its relevant configuration in Co-Proc Mismatches</b>		Warning	MM-DD-YY   HRS: MIN:SEC   IO/IO-Link   <Module Position>   IO Configuration Mismatch	IO/IO-Link bit = 1 Warning bit = 1	# It is auto corrected by Co-Proc at Start-up by default configuration in IO Module
<b>I2C Communication - ADC &lt;Warning&gt;</b>		Warning	MM-DD-YY   HRS: MIN:SEC   IO/IO-Link   <Module Position->   ADC - I2C Communication Break	IO/IO-Link bit = 1 Warning bit = 1	# User can perform the following option: Option 1: Eliminate the Noise Source
<b>USART Communication - IO-Link Transceiver &lt;Warning&gt;</b>		Warning	MM-DD-YY   HRS: MIN:SEC   IO/IO-Link   <Module Position>   IO- Link Transceiver - USART <USART No> Communication Break  where <USART No.> varies from 0 to 3	IO/IO-Link bit = 1 Warning bit = 1	# User can perform the following option: Option 1: Eliminate the Noise Source
<b>External Flash Corruption</b>		Error	MM-DD-YY   HRS: MIN:SEC   IO/IO-Link   <Module Position>   External Flash Corrupted	IO/IO-Link bit = 1 Error bit = 1	# User can perform the following options: Option 1: Power Cycle the Device Option 2: Replace the Device

# Troubleshooting

Description	Area/Module	Category	Event Log Message	Process Input Status Bits	User Actions
			Format: Date   Time   Module   Module Position   Description		
<b>I2C Communication - ADC &lt;Fault&gt;</b>	IO/IO-Link	Error	MM-DD-YY   HRS: MIN:SEC   IO/IO-Link   <Module Position>  ADC - I2C Communication Break	IO/IO-Link bit = 1 Error bit = 1	# User can perform the following options: Option 1: Eliminate the Noise Source Option 2: Power Cycle the Device Option 3: Replace the Device
<b>SPI Communication - IO-Link Transceiver &lt;Fault&gt;</b>		Error	MM-DD-YY   HRS: MIN:SEC   IO/IO-Link   <Module Position>  IO- Link Transceiver - SPI Communication Break	IO/IO-Link bit = 1 Error bit = 1	# User can perform the following options: Option 1: Power Cycle the Device Option 2: Replace the Device
<b>USART Communication - IO-Link Transceiver &lt;Fault&gt;</b>		Error	MM-DD-YY   HRS: MIN:SEC   IO/IO-Link   <Module Position>   IO-Link Transceiver - USART <USART No> Communication Break  where <USART No> varies from 0 to 3	IO/IO-Link bit = 1 Error bit = 1	# User can perform the following options: Option 1: Eliminate the Noise Source Option 2: Power Cycle the Device Option 3: Replace the Device
<b>IO-Link - Validation Failure</b>		Warning	MM-DD-YY   HRS: MIN:SEC   IO/IO-Link   <Module Position>   IO-Link <Port No> - Validation Failure  where <Port No> varies from 0 to 11	Refer to Table 39	# User can perform the following options: Option 1: Need to replace IO-Link sensor with valid Vendor ID, Device ID and/or Serial Number Option 2: Reconfigure Port to No Validation
<b>IO-Link - Short Circuit</b>		Error	Note: This will be logged as part of IO-Link Events	Refer to Table 39	# User can perform the following options: Option 1: Need to remove short circuit by replacing IO-Link Sensor
<b>IO-Link - Data Storage Error</b>		Warning	Note: This will be logged as part of IO-Link Events	Refer to Table 39	# User can perform the following options: Option 1: Need to replace the IO-Link sensor with matching Device ID and Vendor ID of data storage Option 2: Reconfigure Port to Disable/ Clear Data Storage
<b>IO-Link - Process Data Invalid</b>		Error	MM-DD-YY   HRS: MIN:SEC   IO/IO-Link   <Module Position>  IO-Link <Port No> - Process Data Invalid  where <Port No> varies from 0 to 11	Refer to Table 39	# User can perform the following option: Option 1: Connect the IO-Link sensor
<b>IO-Link - Device Communication Lost</b>		Error	Note: This is logged as part of IO-Link Events	Refer to Table 39	# User can perform the following option: Option 1: Connect the IO-Link sensor
<b>Invalid IP Address - Rotary Switch Out of Range</b>	Network	Warning	MM-DD-YY   HRS: MIN:SEC   Network   ---   Invalid IP Address - Rotary Switch Out of Range	Network Bit = 1 Warning Bit = 1	# User can perform the following option: Option 1: Set the correct IP address by setting the Rotary Switch value within valid range

# Troubleshooting

Description	Area/Module	Category	Event Log Message Format: Date   Time   Module   Module Position   Description	Process Input Status Bits	User Actions
<b>PLC - Output Access Disabled</b>	Network	Warning	MM-DD-YY   HRS: MIN:SEC   Network   ---   PLC - Output Access - Output Access Disabled	Network Bit = 1 Warning Bit = 1	# User can perform the following options: Option 1: Change Device Ownership since PLC is not the current owner of the device. Owner change options: 1. Exit Configure Mode of PCH Config Utility/Webserver/Bluetooth App 2. Exit Valve Testing Mode 3. Exit FTP Mode
<b># Master/PLC connected At least one Modbus message received</b>	Network - MODBUS	Event + B40	MM-DD-YY   HRS: MIN:SEC   Network   ---   Master/PLC Connected	NA	# No Action Required
<b># Master/PLC disconnected Connection Timeout</b>		Event + B40	MM-DD-YY   HRS: MIN:SEC   Network   ---   Master/PLC Disconnected	NA	# User can perform the following option: Option 1: Check connection with Master/PLC and reconnect to PCH Portal if disconnected or halted

## CHAPTER - 7 **Abbreviation List**

# Abbreviation List

## 7.1 Abbreviations

**Table 57** — Abbreviations List

<b>Acronym</b>	<b>Definition</b>
ADC	Analog to Digital Converter
AP	Auxiliary Power
AUX	Auxiliary
BLE	Bluetooth Low Energy
BT	Bluetooth Module Status/Bluetooth
CH	Channel
Comm	Communication
DBT	De-bounce Time
DI	Digital Input
DID	Device ID
DIN	Digital Inversion
DIO	Digital Input Output
DIP	Dual In-line Package
DO	Digital Output
DS	Device Status
FM	Fault Mode
FS	Fuse Status
GND	Ground
IO	Input Output
IP	Internet Protocol
IP65	Ingress Protection 65
LED	Light Emitting Diode
LOG	Logic
LP	Logic Power
MS	Module Status
NS	Network Status
OTG	On-The-Go
PCH	Parker Communication for H-Series
PLC	Programmable Logic Controller
RESV	Reserved
USB	Universal Serial Bus
VAUX	Auxiliary Voltage
VID	Vendor ID
VLOG	Logic Voltage

---

CHAPTER - 8 **Appendix**

## 8.1 Process Input Data Registers

1. Process Input Data Registers can be accessed bitwise using the function code 02 to read the single bit or multiple bits.
2. Master/PLC must add the below offsets to the base address while accessing the registers.

Example: If the 5-digit addressing is used by master and base address of Discrete Input Register is decimal 10,000, then "IOA" Data Address is 10,000+ 672 = 10,672 decimal.

**Table 58 — Process Input Data Bitwise Registers Address**

Process Data	Parameter	Modbus Register Address	
		Decimal	Hex
Device Control Status	MS/ Coproc	0	0x0000
	Aux V	1	0x0001
	Logical V	2	0x0002
	Network	3	0x0003
	IO/IOLINK	4	0x0004
	Valve	5	0x0005
	Safety	6	0x0006
	External Module	7	0x0007
	Fault	8	0x0008
	Warning	9	0x0009
	Trending Data	10	0x000A
	Logic Current	11	0x000B
	Aux Current	12	0x000C
	Temp Warning	13	0x000D
	Ext Sensor Power Fault	14	0x000E
	Target Count	15	0x000F
	FRS	16	0x0010
	OC	17	0x0011
	OC1	18	0x0012
	OC2	19	0x0013
	OC3	20	0x0014
	RESV	21	0x0015
	RESV	22	0x0016
	RESV	23	0x0017
	SS 1	24	0x0018
	SS 2	25	0x0019
	SS 3	26	0x001A
	SS 4	27	0x001B
	SS 5	28	0x001C
SS 6	29	0x001D	

Process Data	Parameter	Modbus Register Address	
		Decimal	Hex
Device Control Status	SS 7	30	0x001E
	SS 8	31	0x001F
	VF00	32	0x0020
	VF01	33	0x0021
	VF02	34	0x0022
	VF03	35	0x0023
	VF04	36	0x0024
	VF05	37	0x0025
	VF06	38	0x0026
	VF07	39	0x0027
	VF08	40	0x0028
	VF09	41	0x0029
	VF10	42	0x002A
	VF11	43	0x002B
	VF12	44	0x002C
	VF13	45	0x002D
	VF14	46	0x002E
	VF15	47	0x002F
	VF16	48	0x0030
	VF17	49	0x0031
	VF18	50	0x0032
	VF19	51	0x0033
	VF20	52	0x0034
	VF21	53	0x0035
	VF22	54	0x0036
	VF23	55	0x0037
	VF24	56	0x0038
	VF25	57	0x0039
	VF26	58	0x003A
	VF27	59	0x003B
	VF28	60	0x003C
VF29	61	0x003D	
VF30	62	0x003E	
VF31	63	0x003F	
Standard Inputs Data	I0A	672	0x02A0
	I0B	673	0x02A1
	I1A	674	0x02A2
	I1B	675	0x02A3

Process Data	Parameter	Modbus Register Address	
		Decimal	Hex
	I2A	676	0x02A4
	I2B	677	0x02A5
	I3A	678	0x02A6
	I3B	679	0x02A7
	I4A	680	0x02A8
	I4B	681	0x02A9
	I5A	682	0x02AA
	I5B	683	0x02AB
	I6A	684	0x02AC
	I6B	685	0x02AD
	I7A	686	0x02AE
	I7B	687	0x02AF
	I8A	688	0x02B0
	I8B	689	0x02B1
	I9A	690	0x02B2
	I9B	691	0x02B3
	I10A	692	0x02B4
	I10B	693	0x02B5
	I11A	694	0x02B6
	I11B	695	0x02B7

## 8.2 Process Output Data Registers

1. Process Output Data Registers can be accessed bitwise using the function code as below.

- a) Function Code 01: To Read the single or multiple coil/output.
- b) Function Code 05: To Write a single coil/output.
- c) Function Code 15: To Write multiple coils/outputs.

2. Master/PLC must add the below offsets to the base address while accessing the registers.

Example: If the 5-digit addressing is used by master and base address of Coil Register is decimal 00000, then "O1A" Data Address is 00000+ 0002 = 00002 decimal.

**Table 59 — Process Output Data Bitwise Registers Address**

Process Data	Parameter	Modbus Register Address	
		Decimal	Hex
Standard Output Data	O0A	0	0x0000
	O0B	1	0x0001
	O1A	2	0x0002
	O1B	3	0x0003
	O2A	4	0x0004
	O2B	5	0x0005
	O3A	6	0x0006
	O3B	7	0x0007
	O4A	8	0x0008
	O4B	9	0x0009
	O5A	10	0x000A
	O5B	11	0x000B
	O6A	12	0x000C
	O6B	13	0x000D
	O7A	14	0x000E
	O7B	15	0x000F
	O8A	16	0x0010
	O8B	17	0x0011
	O9A	18	0x0012
	O9B	19	0x0013
	O10A	20	0x0014
	O10B	21	0x0015
	O11A	22	0x0016
O11B	23	0x0017	
Device Control	RST	24	0x0018
	RESV	25	0x0019
	RESV	26	0x001A
	RESV	27	0x001B

Process Data	Parameter	Modbus Register Address	
		Decimal	Hex
Device Control	RESV	28	0x001C
	RESV	29	0x001D
	RESV	30	0x001E
	RESV	31	0x001F
Valve Outputs	V00	32	0x0020
	V01	33	0x0021
	V02	34	0x0022
	V03	35	0x0023
	V04	36	0x0024
	V05	37	0x0025
	V06	38	0x0026
	V07	39	0x0027
	V08	40	0x0028
	V09	41	0x0029
	V10	42	0x002A
	V11	43	0x002B
	V12	44	0x002C
	V13	45	0x002D
	V14	46	0x002E
	V15	47	0x002F
	V16	48	0x0030
	V17	49	0x0031
	V18	50	0x0032
	V19	51	0x0033
	V20	52	0x0034
	V21	53	0x0035
	V22	54	0x0036
	V23	55	0x0037
	V24	56	0x0038
	V25	57	0x0039
	V26	58	0x003A
	V27	59	0x003B
	V28	60	0x003C
	V29	61	0x003D
	V30	62	0x003E
V31	63	0x003F	

## 8.3 IO-Link Events

### 8.3.1 IO-Link Event Qualifier

The following list of tables indicates the permissible values for various fields of Event Qualifier.

**Table 60** — Permissible Values for Instances

Definition	Value
Unknown	0
Reserved	1 to 3
Application	4
Reserved	5 to 7

**Table 61** — Permissible Values for Source

Definition	Value
Device (remote)	0
Master (local)	1

**Table 62** — Permissible Values for Event Type

Definition	Value
Reserved	0
Notification	1
Warning	2
Error	3

**Table 63** — Permissible values for mode

Definition	Value
Reserved	0
Event single shot	1
Event disappears	2
Event appears	3

### 8.3.2 IO-Link Event Codes

The following table lists the PCH Portal specific events. Refer to IO-Link Specification for the Events defined by IO-Link Standard. For Events generated by IO-Link Slave device, refer to the same document.

**Table 64 — PCH Portal specific events**

<b>Event Code</b>	<b>Event Description</b>
0xC101	Overtemperature Shutdown Level event error code
0xC102	Overtemperature Warning Level event error code
0xC103	Vdd Supply 0V event error code
0xC104	Vdd Supply UV event error code
0xC105	Vdd Supply UVLO event error code
0xC106	VL Supply UVLO event error code
0xC107	Wake-up event error code
0xC108	L+ Overcurrent Timeout event error code
0xC109	L+ Power Changed event error code
0xC10A	CQ Overcurrent Timeout event error code
0xC10B	C Sense event error code
0xC201	Data Storage EEPROM access error code

## 8.4 Power Consumption Chart

**Table 65** — Power Consumption

Module Config	Logic Power			Auxiliary Power				
	Theoretical Max Module Power Draw	Power Available for PCH Network Portal	Power Available for Pass Through	Theoretical Max Module Power Draw	Power Available after Module Draw	Valve Power Draw	Power Available for PCH Network Portal	Power Available for Pass Through
	Logic (A)	Logic (A)	Logic (A)	Aux (A)	Aux (A)	Aux (A)	Aux (A)	Aux (A)
AAA	8.000	0.000	12.000	4.256	7.744			
AAB	6.000	2.000	14.000	9.056	2.944			
AAC	7.500	0.500	12.500	8.656	3.344			
AAN	6.000	2.000	14.000	4.256	7.744			
ABB	4.000	4.000	16.000	12.000	0.000			
ABC	6.000	2.000	14.000	12.000	0.000			
ABN	5.000	3.000	15.000	9.056	2.944			
ACC	7.000	1.000	13.000	12.000	0.000			
ACN	5.500	2.500	14.500	8.656	3.344			
BBB	5.000	3.000	15.000	12.000	0.000			
BBC	3.500	4.500	16.500	12.000	0.000			
BBN	2.000	6.000	18.000	12.000	0.000			
BCC	4.000	4.000	16.000	12.000	0.000			
BCN	2.500	5.500	17.500	12.000	0.000			
CCC	4.500	3.500	15.500	12.000	0.000			
CCN	3.000	5.000	17.000	12.000	0.000			

**NOTE:** “To obtain ‘Power Available for PCH Network Portal’, subtract ‘Valve Power Draw’ from ‘Power Available after Module Draw’. To obtain ‘Power Available for Pass Through’, subtract 20 A by ‘Power Available for PCH Network Portal’”.

## 8.5 Ordering information

The part number written on the label for the PCH Network Portal can be understood using the below model number structure. IMPORTANT: This part number cannot be purchased from the factory. In order to purchase a PCH Network Portal, refer to the published catalog of the PCH Network Portal for the full end plate kit part number. This can be found at the product landing page:

<https://ph.parker.com/us/17571/en/pch-network-portal/pch-portal>

For any questions, please contact [pdnapps@parker.com](mailto:pdnapps@parker.com).

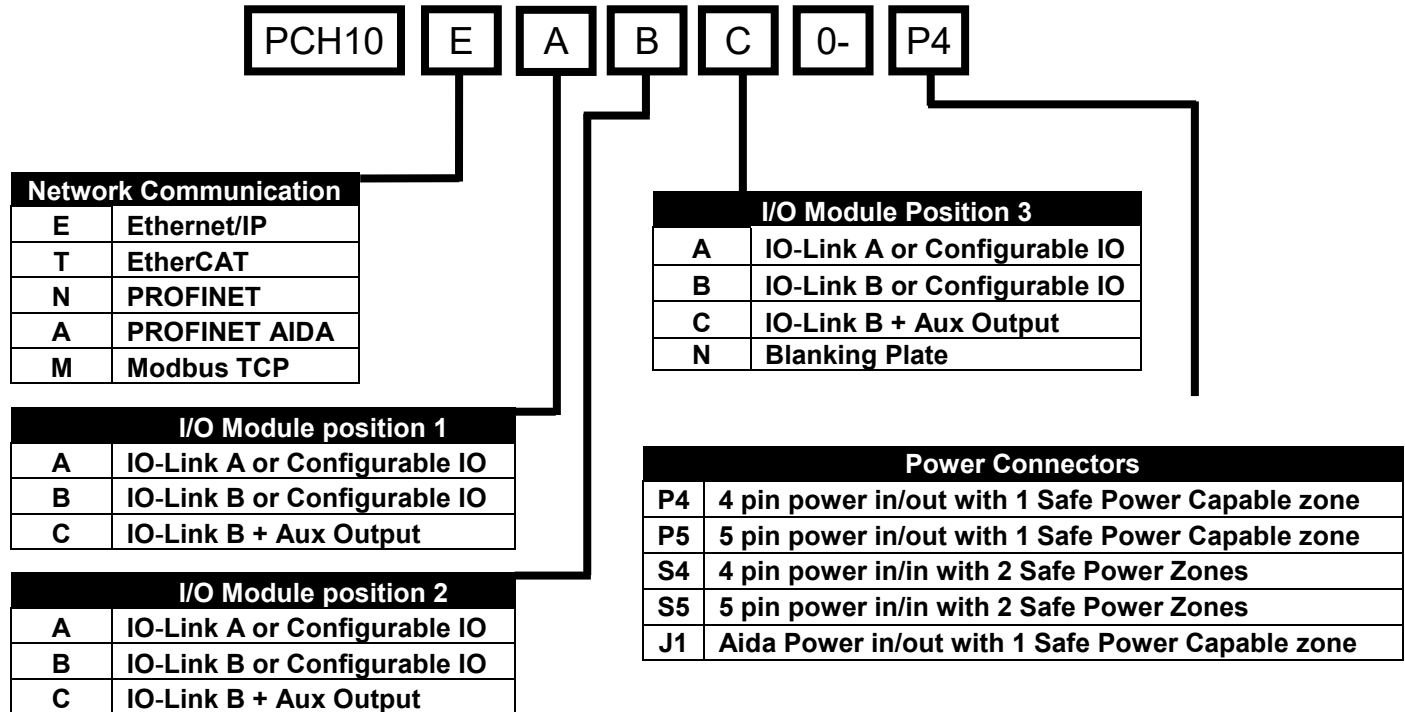

## 8.6 Connectivity and Integration Support

Network Connectivity Site

<https://promo.parker.com/promotionsite/network-connectivity/us/en/home>



Network Connectivity – Resource Library

[http://solutions.parker.com/PDN\\_NetworkConnectivityResourceLibrary](http://solutions.parker.com/PDN_NetworkConnectivityResourceLibrary)

Network Connectivity – Software Files

[http://solutions.parker.com/PDN\\_softwarefiles](http://solutions.parker.com/PDN_softwarefiles)

---

# Parker Hannifin Corporation

## Pneumatic Division

**Americas** USA, Canada, Mexico

[c-parker@parker.com](mailto:c-parker@parker.com)

1-800-272-7537