

CNG Time Fill Post User Guide



ENGINEERING YOUR SUCCESS.

CONTENTS

| | |
|--|----------|
| 1. General Instructions..... | 1 |
| 1.1. Scope..... | 1 |
| 1.2. Fail Safe..... | 1 |
| 1.3. Distribution..... | 1 |
| 1.4. User Responsibility..... | 1 |
| 1.5. Safety Devices..... | 1 |
| 1.6. Warning Labels..... | 1 |
| | |
| 2. Product Selection Instructions..... | 2 |
| 2.1. Working Pressure..... | 2 |
| 2.2. Fluid Compatibility..... | 2 |
| 2.3. Temperature Rating..... | 2 |
| 2.4. Leakage..... | 2 |
| 2.5. Severe Leakage..... | 3 |
| 2.6. Environment..... | 3 |
| 2.7. Intended Use..... | 3 |
| | |
| 3. Product Installation And Operating Instructions..... | 4 |
| 3.1. Pre-Installation Product Inspection..... | 4 |
| 3.2. Installation and Operating Considerations..... | 4 |
| 3.3. Fitting Installation..... | 5 |
| 3.4. Caps and Plugs..... | 5 |
| 3.5. Leak Test..... | 5 |
| 3.6. Functional Test..... | 6 |
| 3.7. Operating Instructions..... | 6 |
| | |
| 4. Product Maintenance Instructions..... | 9 |
| 4.1. Maintenance..... | 9 |
| 4.2. Inspection..... | 9 |
| 4.3. Routine Maintenance..... | 10 |
| 4.4. Removal..... | 10 |

| | | |
|-----------|---|-----------|
| 4.5. | Servicing | 11 |
| 4.6. | Putting Serviced Product Back into Operation..... | 11 |
| 4.7. | Replacement Intervals | 11 |
| 5. | Limitations | 11 |
| 5.1. | Liability..... | 11 |
| 5.2. | Versions..... | 11 |
| | Appendix: Fitting Assembly Instructions..... | 12 |

Definition of symbols used in this guide:



DANGER indicates a hazardous situation which, if not avoided, will result in death or serious injury.



WARNING indicates a hazardous situation which, if not avoided, could result in death or serious injury.



CAUTION, used with the safety alert symbol, indicates a hazardous situation which, if not avoided, could result in minor or moderate injury.



NOTICE addresses practices not related to personal injury.

Acronyms and abbreviations used in this guide:

| Acronym | Definition |
|---------|---|
| AHJ | Authority Having Jurisdiction |
| AISI | American Iron and Steel Institute |
| ANSI | American National Standards Institute |
| ASME | American Society for Mechanical Engineers |
| ASTM | American Society for Testing and Materials |
| AWG | American Wire Gauge |
| CEC | Canadian Electrical Code |
| CDA | Controllable Drive Actuator |
| CNG | Compressed Natural Gas |
| CPU | Central Processing Unit |
| CSA | Canadian Standards Association |
| ESD | Emergency Shut-down Device |
| EYA | Hazardous site fitting as defined by UL 886 |
| LCD | Liquid Crystal Display |
| LED | Light Emitting Diode |
| MSHA | Mine Safety and Health Administration |
| NEC | National Electrical Code |
| NEMA | National Electrical Manufacturers Association |
| NFPA | National Fire Protection Association |
| NGV | Natural Gas Vehicle |
| NIOSH | National Institute for Occupational Safety and Health |
| NPT | National Pipe Thread |
| NTEP | National Type Evaluation Program |
| PPE | Personal Protection Equipment |
| PTFE | Polytetrafluoroethylene |
| POS | Point of Sale |

USER GUIDE FOR VERIFLO DIVISION CNG TIME FILL POST ASSEMBLIES

This product is designed to carry flammable gas at high pressure (Natural Gas at 3,600 psig service pressure). Before using any Parker CNG (Compressed Natural Gas) time fill post assembly or related accessories, it is important that you read, understand, and comply with the following instructions.



Failure or improper selection or improper use of CNG time fill hoses or related accessories can cause death, personal injury, and property damage. Possible consequences of failure or improper selection or improper use of CNG time fill hoses or related accessories include but are not limited to:

- Parts thrown off at high speed.
- High velocity fluid discharge.
- Explosion or burning of the conveyed fluid.
- Contact with suddenly moving or falling objects that are to be held in position or moved by the conveyed fluid.
- Dangerously whipping hose.
- Contact with conveyed fluids that may be hot, cold, toxic, or otherwise injurious.
- Injection by high-pressure fluid discharge.
- Asphyxiation by accumulation of vapors in a confined space.

To ensure safe operation, only trained and qualified professionals with certifications in accordance with the applicable codes shall perform installation, maintenance, repair, removal, or replacement of this high pressure Natural Gas product for motor vehicle fueling.

Attempting to operate a CNG fuel system without proper training is dangerous. Only properly trained personnel should operate this device in the field. Please take the time to train field personnel in the correct procedures for using this device to fuel motor vehicles.

1. GENERAL INSTRUCTIONS

1.1. Scope

This user guide is designed to cover general guidelines on the installation, operation, and maintenance of Veriflo Division CNG Time Fill Post Assemblies (“products”). This user guide supplements and is to be used with the generic Parker Hose and Fitting Safety Guide Bulletin 4400-B.1. For copies of Safety Guide, call (330) 296-2871 or 1-800-CPARKER, or go to www.parker.com/safety.

1.2. Fail Safe

Veriflo CNG products can and do fail without warning for many reasons. Design all systems and equipment in a fail-safe mode, so that failure of Veriflo CNG products will not endanger persons or property.

1.3. Distribution

Provide a copy of this user guide to each person that is responsible for selection, installation, operation, maintenance or service of Veriflo CNG Time Fill Post Assemblies. Do not select or use Veriflo CNG Time Fill Post Assemblies without thoroughly reading and understanding this user guide.

1.4. User Responsibility

Due to the wide variety of operating conditions and applications for Veriflo CNG Time Fill Post Assemblies, Parker and its distributors do not represent or warrant that this particular Veriflo CNG product is suitable for any specific end use system. This user guide does not analyze all technical parameters that must be considered in product selection. The user, through its own analysis and testing, is solely responsible for:

- Making the final selection of the Veriflo CNG product;
- Assuring that all user’s performance, endurance, maintenance, safety, and warning requirements are met and that the application presents no health or safety hazards;
- Complying with all existing warning labels and / or providing all appropriate health and safety warnings on the equipment on which the Veriflo products are used;
- Assuring compliance with all applicable government and/or industry codes, laws, regulations, or standards;
- Wearing appropriate personal protection equipment.

1.5. Safety Devices

Safety devices should not be removed, or defeated.

1.6. Warning Labels

Warning labels should not be removed, painted over or otherwise obscured.

2. PRODUCT SELECTION INSTRUCTIONS

2.1. Working Pressure

The installer/user is responsible for assuring that the pressures applied to the product will never exceed the maximum allowable working pressure (MAWP) of the product, the MAWP of any options and accessories connected to the product, and the MAWP of any other system component. Consult product labeling for maximum allowable working pressures. Additional operating pressure considerations: CNG Time Fill Post selection must be made so that the published rated pressure of the hose assembly is equal to or greater than the maximum system pressure. Surge pressures in the system higher than the MAWP of the hose assembly will shorten the product life or result in unpredictable failure.



Do not confuse burst pressure or other pressure values with maximum allowable working pressure and do not use burst pressure or other pressure values for this purpose.

2.2. Fluid Compatibility

Veriflo CNG Time Fill Post Assemblies are for use with Compressed Natural Gas for motor vehicle use only.

2.3. Temperature Rating

Never exceed the temperature ratings of a product. Excessive heat or cold can shorten the life expectancy of a product, cause improper function, and product rupture. Veriflo CNG Time Fill Post Assemblies are rated for use between -40 °F and +150 °F. The installer is responsible for assuring that fluid and ambient temperatures, both steady and transient, do not exceed these limitations. Use caution and hand protection when connecting or disconnecting couplings that are heated or cooled by the media they are conducting or by their environment.

2.4. Leakage

Leakage can create hazardous situations due to exposure to the process fluid, accumulation of vapors in a confined space, unintended chemical reactions, loss of system pressure, or unexpected transfer of fluids and pressures within the system. Veriflo CNG Time Fill Post Assemblies are specified to be “bubble tight” at the maximum allowable working pressure (MAWP). Bubble tight means that a certified leak detecting solution does not form bubbles when applied to fittings.

2.5. Severe Leakage

The user must address in their system design, product selection, and product usage any hazards that may result from severe leakage due to product or system failure. Good system design requires consideration of the possibility of severe internal and external leakage and may require safety pressure relief devices and secondary fluid containment. Severe leakage can create hazardous situations due to exposure to the process fluid, accumulation of vapors in a confined space, unintended chemical reactions, loss of system pressure, or unexpected transfer of fluids and pressures within the system.

2.6. Environment

Many environmental conditions can affect the integrity and suitability of a product for a given application. Care must be taken to ensure that CNG products are either compatible with or protected from the environment (that is, surrounding conditions) to which they are exposed. Environmental conditions including but not limited to ultraviolet radiation, ozone, moisture, water, salt water, chemicals, and air pollutants can cause degradation and premature failure.

2.7. Intended Use

This product is intended for CNG Time Fill only and is not to be used for de-fueling, or as a vent stack for de-fueling, or other than intended purpose. CNG Time Fill Post Assemblies are not for household/home use.

3. PRODUCT INSTALLATION & OPERATING INSTRUCTIONS

3.1. Pre-Installation Product Inspection

Prior to assembly or installation, a careful examination of the product must be performed. All products must be checked for correct style, size, model number, and damage. DO NOT use any product that displays any signs of nonconformance or damage.

3.2. Installation and Operating Considerations

- Installation shall conform with the requirements of the authorities having jurisdiction or, in the absence of requirements, with the Standards NFPA 52, Compressed Natural Gas (CNG) Vehicular Fuel Systems, or CAN/CSA-B108, NGV Fuelling Stations Installation Code, as applicable.
- Installation, operation, removal, and servicing of these products shall be performed by qualified professionals with certifications in accordance with the applicable codes who have been trained and equipped for the handling, use and servicing of pressurized fluids and systems.
- The installer must identify the inlet fill and vent ports labeled on the product to ensure proper connection of hose assemblies.



Do not interchange fill and vent lines from their intended uses. Vent line should not be pressurized.

- Attach CNG Time Fill Post Assembly to a foundation with anchoring systems design to comply with the requirements of the adapted building code for the appropriate seismic and wind conditions. Parker recommends that a Professional Engineer (PE) review site installation design to ensure compliance.
- Ensure electrical bond to ground lug provided on post. Reference NFPA 77 and/or API RP 2003.
- After installation and servicing, the product must be tested for proper function and leakage. Leak test methods should be appropriate for the system leak integrity requirements.
- Do not use a product or operate a system if there is evidence of contamination (e.g. debris, particles, oils, lubricants, grease, etc.).
- A particulate filter should be installed in the system to prevent particulate matter larger than 5 microns from being delivered to a vehicle.
- Do not interchange products, components, and accessories with those that have been used in other types of gas service.
- Prior to installation, follow lockout and tagout procedures for the system and equipment. Follow all government, state and local safety and servicing practices including, but not limited, to all OSHA Lockout Tagout procedures (OSHA Standard – 29 CFR, Part 1910.147, Appendix A, The Control of Hazardous Energy – Lockout / Tagout).
- Always wear appropriate personal protection equipment such as approved safety glasses, face shield, apron, gloves, etc. during installation and/or operation of this product.
- Prior to pressurization or operation, the user should be familiar with the location and proper operation of all applicable safety equipment on site which may include, but not be limited to fire extinguishers and emergency shutdown systems.

3.3. Fitting Installation

Use a thread sealant, lubricant, or a combination of both when assembling pipe thread joints. Be sure the sealant is compatible with the system fluid or gas. The sealant must also be compatible with the maximum allowable working pressure. Use the flats provided when installing fittings. Do not use pipe wrenches or a vise on other parts of the hose assembly to hold it when installing or removing fittings as damage or loosening of threaded joints in the hose assembly could result. Do not apply excessive torque to taper pipe threads because cracking or splitting of the female component can result. There are two adapter fitting sizes provided. Both pipe thread sizes, 1/4-18 and 3/8-18, require 2 to 3 turns from finger tight. The 1/4-18 is vent and the 3/8-18 is fill. See Appendix for further tapered pipe thread and swivel nut hose connection instructions to the JIC 37° flared end of the same adapter fittings.



Never clamp or pinch the flexible part of the hose assembly with any wrench, vise, or tool.

3.4. Caps and Plugs

Use dust caps and plugs when hose assemblies are not connected to exclude dirt and contamination and to protect critical surfaces from damage.

3.5. Leak Test

After proper installation, the units should be tested for leaks. The pressures to be tested should be 100 psig followed by 3600 psig.

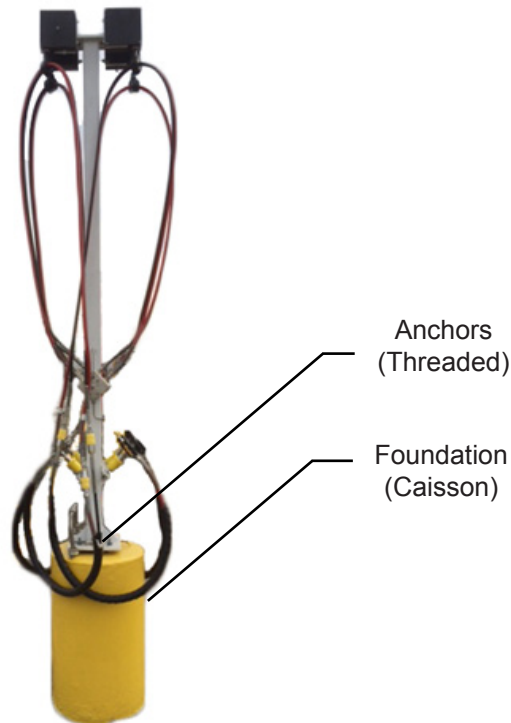

Figure 1. Typical installation of post

3.6. Functional Test

Operate the time fill post assembly starting at a low pressure and gradually increase to maximum operating pressure. Check for possible malfunctions and leaks. Personnel must avoid potential hazardous areas while testing and using the system.

3.7. Operating Instructions

NOTICE

An Emergency Shut Down (ESD) button should be available at all US-based CNG filling locations in accordance with NFPA 52. Operating personnel should locate the ESD on prior to using CNG time fill systems.



3.7.1 The ON/OFF ball valve controls gas supply pressure to the time fill post. Prior to opening the valve to the “ON” position, verify that all manifold ports are properly connected to compatible fill hose assemblies or are securely plugged with NPT fittings for use with pressures over 5000 psig.

WARNING

There shall be no open ports before applying pressure to this product and the system should have already passed a leak test performed by installation or maintenance personnel.

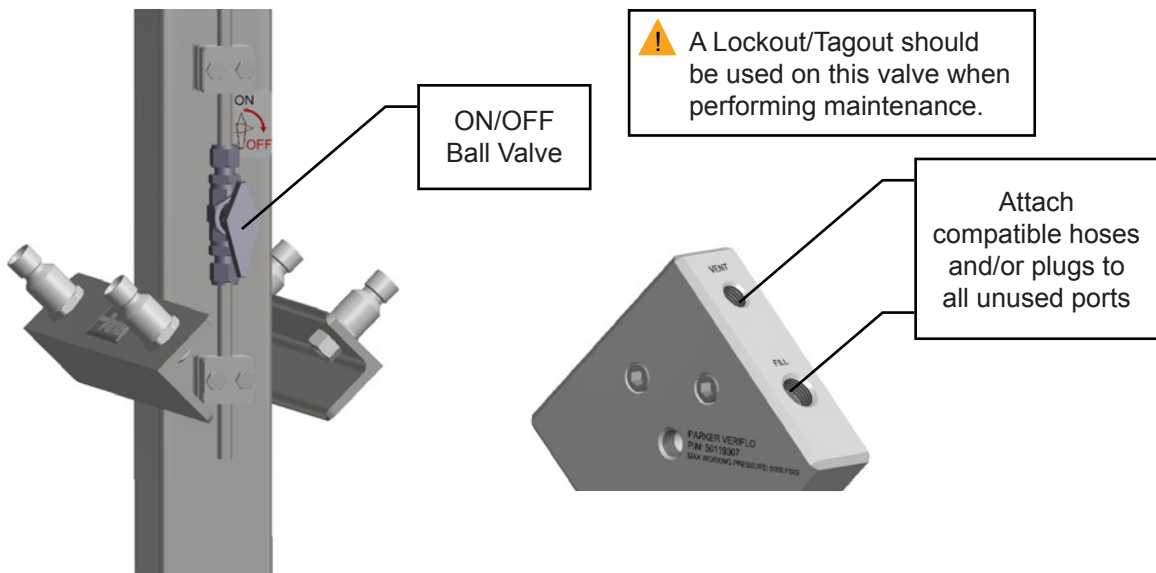

3.7.2 Ensure that the vent openings at the top of the post are free from obstructions.

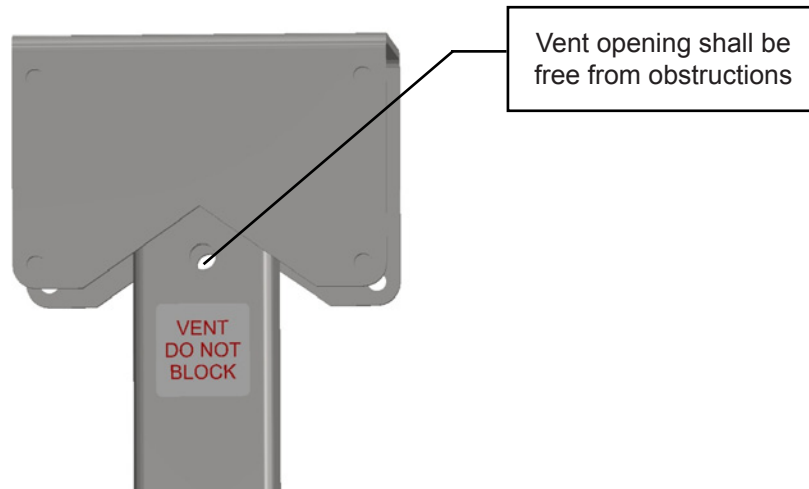

3.7.3 Ensure that the bleed valve is closed by tightening the valve nut snug with a wrench.



High pressure gas will escape from the vent tube on the bleed valve when opened. Always direct the vent hole away from operating personnel.



This valve does not contain packing. It is possible for media to leak through the threads when the valves are open.

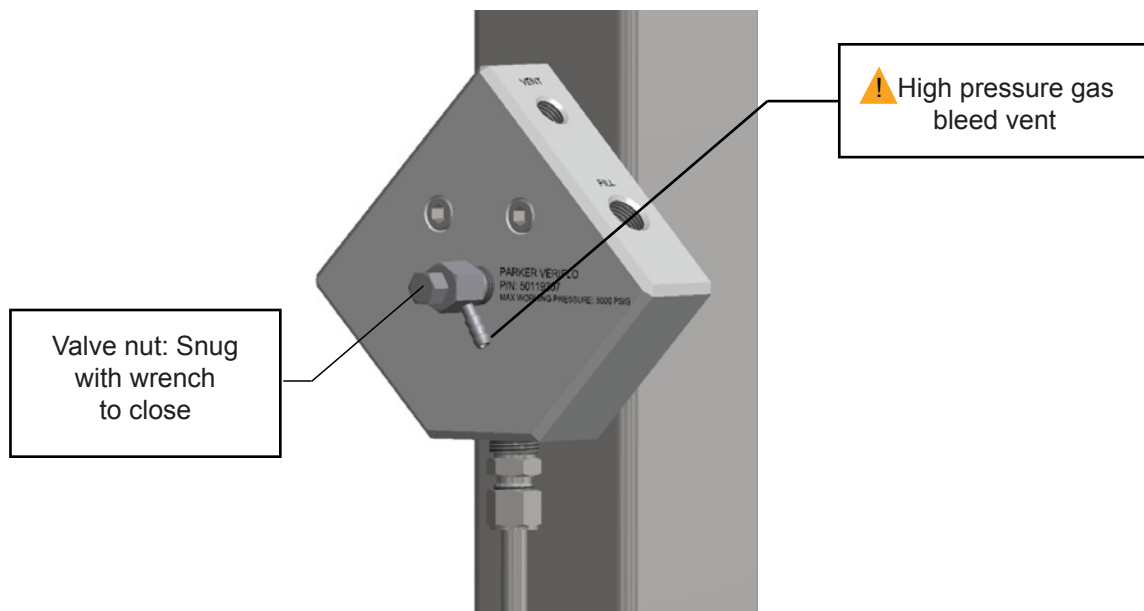

3.7.4 The pressure gauge indicates pressure applied to the post and attached fill hoses. With ball valve in the “ON” position, the post system is pressurized to the gas supply pressure for vehicle fueling. Subsequently switching the ball valve to the “OFF” position will isolate supply pressure, but the time fill post plumbing and hoses will remain pressurized unless pressure is relieved via the bleed vent.

| | |
|---|---|
|  | The time fill post may remain pressurized with the “ON/OFF” valve in the “OFF” position. |
|---|---|

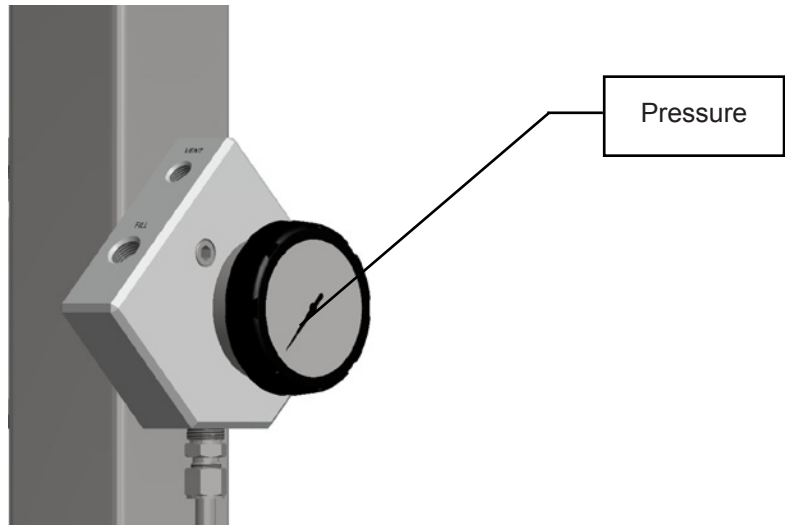

3.7.5 To relieve pressure from time fill post, “ON/OFF” valve must first be switched to the “OFF” position. Bleed valve can then be opened slowly to allow gas to escape. Refer to step 3.7.2 for closing the bleed valve securely. The time fill post system is depressurized when the pressure gauge needle moves counterclockwise and touches the peg stop.

3.7.6 With bleed valve closed securely and the ball valve in the “ON” position, the time fill post is ready for vehicle fueling at the provided supply pressure. For vehicle fueling steps, refer to instructions for the compatible hose assemblies that are in use.

3.7.7 When vehicle fill hose nozzles are not in use, they should be stowed on the nozzle docks provided.

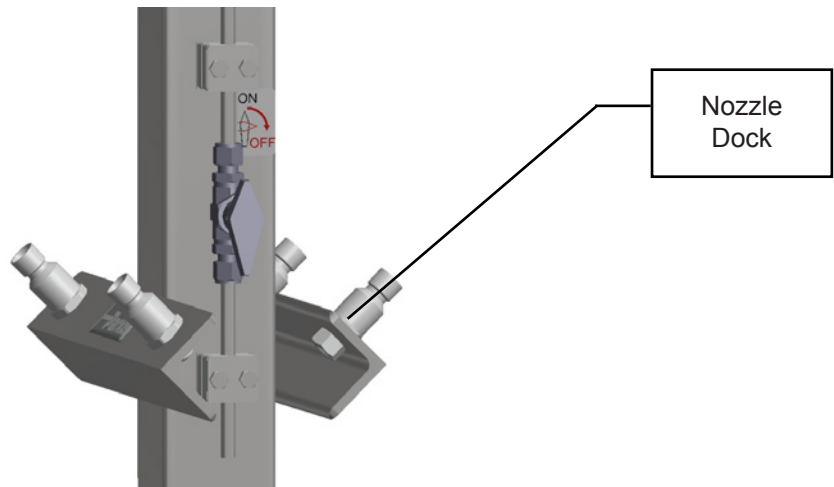

4. PRODUCT MAINTENANCE INSTRUCTIONS



Improper repair or servicing of this product can cause death, personal injury and property damage.

Veriflo Division products must pass rigid acceptance tests before leaving the factory. All repairs and servicing of this product must only be performed by factory certified personnel and tested for operation and leakage. Veriflo Division cannot assume responsibility for the performance or safety of a customer repaired or serviced product or for any damages resulting from failure of a customer repaired or serviced product or otherwise altered product.

4.1. Maintenance

Even with proper selection and installation, product service life may be significantly reduced without a continuing maintenance program. A maintenance program must be established and followed by the user and, at minimum, must include instructions 4.2 through 4.6. Maintenance, inspection, service, and replacement intervals are the sole responsibility of the user and need to be established so that products are replaced before any failure occurs. Important considerations when establishing the frequency of maintenance, inspection, service, and replacement of Veriflo Division CNG products:

- Previous performance experiences including known failures in the application or similar applications.
- Government and/or industrial standards.
- When failures could result in unacceptable down time, equipment damage or personal injury risk.
- The user is solely responsible for determining the frequency of maintenance based on the application, that the recommended checks can be safely performed, and that the recommended checks are adequate to ensure proper and safe operation of the user's system.

4.2. Inspection

A Veriflo Division CNG product that does not comply with the user-recommended checks or malfunctions in any manner must be immediately removed from service. Do not attempt repair. Any of the following conditions requires immediate system shut down and replacement of worn or damaged components.



Never approach a product or system exhibiting these or other abnormal conditions until the system has been shut down and depressurized.

- Escaping fluid and abnormal pressure readings: Escaping fluid and abnormal pressure readings may indicate severe leakage or product or system failure.
- Damaged or degraded components: Any visible signs of abnormal wear or component degradation.
- Corrosion: If any component is corroded, determine whether replacement and/or servicing is necessary.
- Kinked, crushed, or damaged hoses and plumbing: Kinked plumbing can result in restricted fluid flow and lead to unpredictable system behavior.
- Any observed improper system or component function: Immediately shut down the system and correct the malfunction.
- Excessive dirt build-up: Dirt and clutter can mask potentially hazardous situations.

4.3. Routine Maintenance

- Periodically inspect for leakage, wear, abuse, or damage.
- Periodically perform a leak test on entire system.
- Periodically test electrical bonding of ground lug. Reference NFPA 77 and/or API RP 2003
- Remove excessive dirt, grime and clutter from work areas.
- Make sure all required guards and shields are in place. Warnings and specifications on the product should not be covered or painted over. If masking is not possible, contact your local representative for replacement labels.
- Parker CNG Post Assemblies should be tested after installation and before use.

| | |
|---|---|
|  | <p>Matches, candles, open flame or other sources of ignition shall not be used for hose inspection. Leak check solutions should be rinsed off after use.</p> |
|---|---|

4.4. Removal

To avoid unpredictable system behavior that can cause death, personal injury and property damage, before attempting to remove a product from service, follow these important product removal considerations:

- Removal of these products shall be performed by qualified professionals with certifications in accordance with the applicable codes who have been trained and equipped for the handling, use and servicing of pressurized fluids and systems.
- Follow lockout and tagout procedures for the system and equipment as stated in Section 3.2 above.
- Isolate the product from all pressure sources upstream and downstream of the product by closing and locking out the appropriate valves.
- Safely depressurize the product and system, venting all pressure, both upstream and downstream.
- Properly purge hazardous fluids from the product and system.
- Always wear appropriate personal protection equipment such as approved safety glasses, face shield, apron, gloves, etc.
- After device removal, cap all connections to maintain cleanliness within the system.

4.5. Servicing

The CNG Time Fill Post Assemblies do not have any user serviceable parts. Therefore, any issues with the product shall be addressed only by the authorized service representative.

4.6. Putting Serviced Product Back into Operation

Follow the guidelines above for product installation and operating instructions, Section 3 above.

4.7. Replacement Intervals

It is the responsibility of the end user to establish an appropriate maintenance program.

5. LIMITATIONS

5.1. Liability

Parker Hannifin Corporation and its member companies accepts no liability of any kind to any party, and no responsibility for damages or loss suffered by any party, as a result of decisions made, or not made, or actions taken, or not taken, based on this document.

5.2. Versions

It should be noted that the version date of this document supersedes any prior version.

Appendix: Fitting Assembly Instructions

Tapered Pipe Thread Assembly Instructions:

The proper method of assembling tapered threaded connectors is to assemble them finger tight and then wrench tighten further to the specified number of turns from finger tight (T.F.F.T.) given in table S5. The following assembly procedure is recommended to minimize the risk of leakage and/or damage to components.

1. Inspect components to ensure that male and female port threads and sealing surfaces are free of burrs, nicks and scratches, or any foreign material.
2. Apply sealant/lubricant to male pipe threads if not pre-applied. For stainless steel fittings, the use of Parker Threadmate sealant/lubricant is strongly recommended. (Pre-applied dry sealants are preferred over other sealants). With any sealant, the first one to two threads should be left uncovered to avoid system contamination. If PTFE tape is used it should be wrapped 1-1/2 to 2 turns in a clockwise direction when viewed from the pipe thread end.
Caution: More than two turns of tape may cause distortion or cracking of the port.
3. Screw the connector into the port to the finger tight position.
4. Wrench tighten the connector to the appropriate T.F.F.T. values shown in Table S5, making sure that the tube end of a shaped connector is aligned to receive the incoming tube or hose assembly. Never back off (loosen) pipe threaded connectors to achieve alignment.
5. If leakage persists after following the above steps, check for damaged threads and total number of threads engaged.

If threads on the fitting are badly nicked or galled, replace the fitting. If port threads are damaged, re-tap, if possible, or replace the component. If the port is cracked, replace the component.

Normally, the total number of tapered threads engaged should be between 3-1/2 and 6. Any number outside of this range may indicate either under or over tightening of the joint or out of tolerance threads. If it is over tightened, check both threads, and replace the part which has out-of-tolerance threads.

As a general rule, pipe fittings with tapered threads should not be assembled to a specific torque because the torque required for a reliable joint varies with thread quality, port and fitting materials, sealant used, and other factors. Where many of these factors are well-controlled, such as a particular jobs on a assembly floor, a torque range that produces the described results may be determined by test and used in lieu of turns count for proper joint assembly.

| Tapered Pipe Thread Size | | T.F.F.T. |
|--------------------------|----------------|----------|
| BSPT | NPTF | |
| 1/8-28 | 1/8-27 | 2 - 3 |
| 1/4 -19 | 1/4 - 18 | 2 - 3 |
| 3/8 - 19 | 3/8 -18 | 2 - 3 |
| 1/2 - 14 | 1/2 -14 | 2 - 3 |
| 3/4 - 14 | 3/4 - 14 | 2 - 3 |
| 1 - 11 | 1 - 11 1/2 | 1.5 -2.5 |
| 1 1/4 - 11 | 1 1/4 - 11 1/2 | 1.5 -2.5 |
| 1 1/2 -11 | 1 1/2 - 11 1/2 | 1.5 -2.5 |
| 2 -11 | 2 - 11 1/2 | 1.5 -2.5 |

Parker Hannifin Corporation
Veriflo Division
250 Canal Blvd.
Richmond, CA 94804
phone 510 412 1100
fax 510 412 1263
email ngv@parker.com
solutions.parker.com/alternativefuels

