

930Y Series

UHP Stainless Steel Diaphragm Valve
High Flow Manifold

aerospace
climate control
electromechanical
filtration
fluid & gas handling
hydraulics
pneumatics
process control
sealing & shielding

Value Proposition:

The 930Y valve offers the same benefits as the standard two way valve. The “Y” valve configuration allows for a mix of operator combinations, reduces space requirements, and has fewer welds over standard valve alignments.

Pressure and flow requirements are unique to each valve in this offering, please reference the two way data sheet to ensure proper selection.

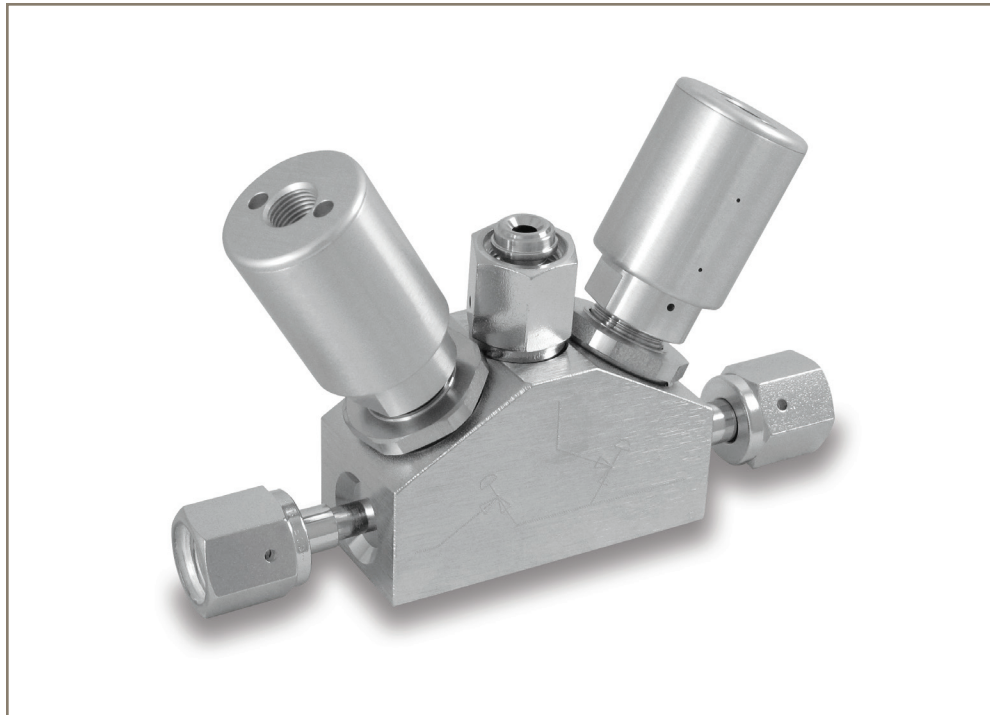

Contact Information:

Parker Hannifin Corporation
Veriflo Division
250 Canal Blvd
Richmond, California 94804

phone 510 235 9590
fax 510 232 7396
veriflo.sales@parker.com

www.parker.com/veriflo
Mobile App: m.parker.com/veriflo

Product Features:

- Standard surface finish of 10 micro inch Ra
- Internally threadless and springless
- Fully functional from vacuum to 300 psig
- High cycle life (including corrosive service)
- 100% Helium leak tested
- Standard full internal electroplish
- Minimal particle generation and particle entrapment areas
- Vericlean™, Veriflo's low sulfur high purity 316L Stainless Steel enhances electropolishing, welding, and corrosion resistance



ENGINEERING YOUR SUCCESS.

930Y Series

Dimensional Drawings

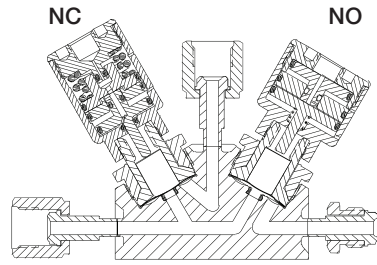

930Y1NO/NCFSMFFA

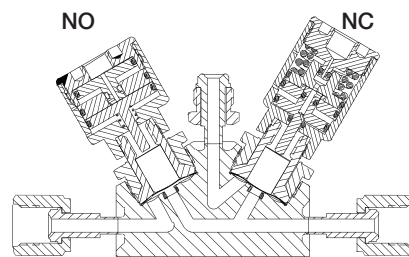
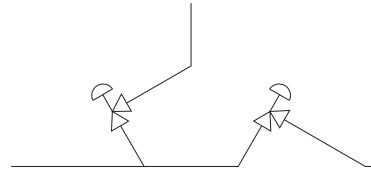

930Y2NC/NOFSMFA

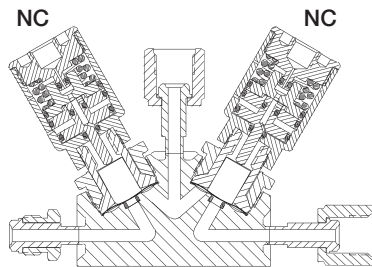
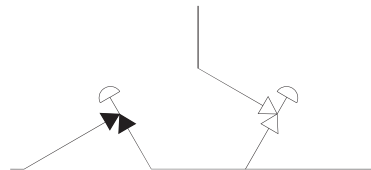

930Y3NC/NCFSFFMA

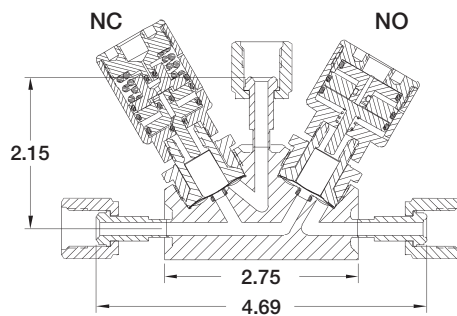
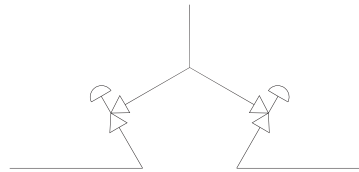

930Y1NO/NCFSFFFA

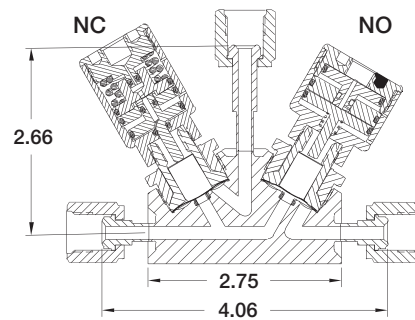

930Y1NO/NCFSFFFB

930Y Series

Ordering Information

Build a 930Y Series valve by replacing the numbered symbols with an option from the corresponding tables below.

Contact factory for most up to date lead time information.

Blue = Configurations that have selections in blue will require a price quote and lead time from the factory.

Sample: **9** **30Y** **1** **NC/NO** **FS** **MMF** **VESP** **A**
 Finished Order: **930Y1NC/NOFSMMFVESPA**

1 Basic Series
 30Y = 930Y

2 Flow Path
 1 = Down Stream Purge
 2 = Up Stream Purge
 3 = Common

3 Activating Device Type (V1/V2)
 NC = Air Operated, Low Pressure, Normally Closed
 NO = Air Operated, Low Pressure, Normally Open
 M = Mini-Lever

4 Port Style
 FS = 1/4" Face Seal
 FS8 = 1/2" Face Seal
 TS = 1/4" Tube Stub
 TS6 = 3/8" Tube Stub
 TS8 = 1/2" Tube Stub

5 Port Configuration
 M = Male Face Seal
 F = Female Face Seal

6 Optional Features
 This section can have multiple options
 PEEK = PEEK™ Seats
 VESP = Vespel® Seats
Recommended for Nitrous Oxide (N2O) Service

7 Dimensions
 A = 4.69 x 2.15
 B = 4.06 x 2.66 (FSF or TS only)

Ordering Example

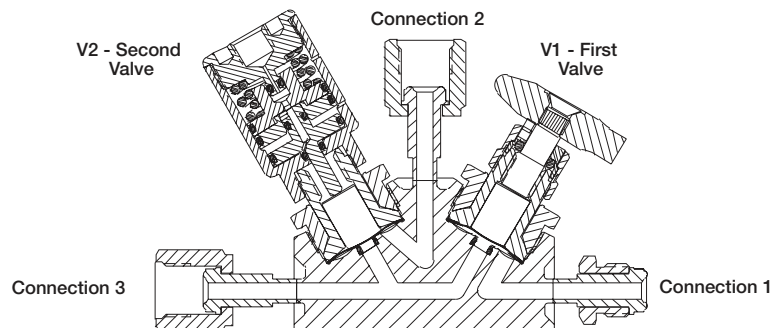

930Y1M/NCFSMFFA

930Y Series

Specifications

Materials of Construction	
Wetted	
Body	VeriClean™ 316L Stainless Steel
Diaphragm	Elgiloy® or equivalent
Seat Options	PCTFE (std), PEEK™ or Vespel®
Non-wetted	
Cap	17-4 Stainless Steel
Nut	316L Stainless Steel
Actuator Housing	Anodized Aluminum
Operating Conditions	
<i>(Operating limits based upon pressure applied at inlet port.)</i>	
Maximum Pressure	
NC, NO	125 psig (8.6 barg)
I, M	300 psig (20.7 barg)
Minimum Pressure	Vacuum
AOP Actuation Pressure	75 psig nominal (5 barg)
Temperature	-40°F to 150°F (-40°C to 66°C)
Bake Out	250°F (121°C) in the open position
AOP Air Inlet	1/8-27 NPT

For additional information on materials of construction, functional performance and operating conditions, please contact factory.

Functional Performance	
Design	
Proof Pressure	
NC, NO	188 psig (13 barg)
I, M	450 psig (31 barg)
Burst Pressure	
NC, NO	375 psig (26 barg)
I, M	900 psig (62 barg)
Flow Capacity	
Process Valve	
NC, NO, I	C _v 0.3
Lever (M)	C _v 0.22
Purge Valve	
	C _v 0.18
Leak Rate	
Inboard Test Method	
Internal	≤ 1 X 10 ⁻⁹ scc/sec He
External	≤ 2 X 10 ⁻¹⁰ scc/sec He
Surface Finish	
	10 micro inch Ra
Internal Volume	
	4.26 cc
Approx. Weight	
	2.1 lbs. (0.95 kg)

Vespel® is a registered trademark of DuPont Performance Elastomers L.L.C.
 Elgiloy® is a registered trademark of Elgiloy Company
 VeriClean™ is a trademark of Parker Hannifin Corporation
 PEEK™ is a trademark of Victrex plc.

OFFER OF SALE:

The items described in this document are hereby offered for sale by Parker-Hannifin Corporation, its subsidiaries or its authorized distributors. This offer and its acceptance are governed by the provisions stated in the detailed "Offer of Sale" elsewhere in this document or available at www.parker.com/veriflo



FAILURE OR IMPROPER SELECTION OR IMPROPER USE OF THE PRODUCTS DESCRIBED HEREIN OR RELATED ITEMS CAN CAUSE DEATH, PERSONAL INJURY AND PROPERTY DAMAGE. THIS DOCUMENT IS FOR REFERENCE ONLY. PLEASE CONSULT FACTORY FOR LATEST PRODUCT DRAWINGS AND SPECIFICATIONS

This document and other information from Parker-Hannifin Corporation, its subsidiaries and authorized distributors provide product or system options for further investigation by users having technical expertise.

The user, through its own analysis and testing, is solely responsible for making the final selection of the system and components and assuring that all performance, endurance, maintenance, safety and warning requirements of the application are met. The user must analyze all aspects of the application, follow applicable industry standards, and follow the information concerning the product in the current product catalog and in any other materials provided from Parker or its subsidiaries or authorized distributors.

To the extent that Parker or its subsidiaries or authorized distributors provide component or system options based upon data or specifications provided by the user, the user is responsible for determining that such data and specifications are suitable and sufficient for all applications and reasonably foreseeable uses of the components or systems.

The products described herein, including without limitation, product features, specifications, designs, availability and pricing are subject to change by Parker Hannifin Corp and its subsidiaries at any time without notice.

Proposition 65 Warning: This product contains chemicals known to the state of California to cause cancer or birth defects or other reproductive harm.

© 2009 Parker Hannifin Corporation



Use mobile device to scan this QR Code.

LitPN: 25000133

Rev: K

Date of Issue 05/2017



ENGINEERING YOUR SUCCESS.