



## Instructions for High Temperature Purge Adapters

### 1. APPLICATION

PGI's Purge Adapters are designed to keep a constant purge from the instrument to the process. The adapter has a connection for the purge media that goes through a filter to the flow metering element, and then into the process keeping the sensing lines from purging.

### 2. INSTALLATION

The adapters do not come with pressure gauges. We recommend using a 1-1/2" face, 1/4" MNPT, center-back mount gauge. **Operating pressure is limited to 1-1/2 times the pressure rating of pressure gauge installed.**

Installation with Purge Adapter and Manifold/Bracket Assembly

Materials	Pressure & Temperature
Grafoil® Seal with Kalrez® O-Ring	6000 psi @ 200°F 1500 psi @ 600°F
Teflon® Pressure Core® Seal with Kalrez® O-Ring	6000 psi @ 200°F 8000 psi @ 450°F
Teflon® Packed Seal with Kalrez® O-Ring	6000 psi @ 200°F 4000 psi @ 500°F

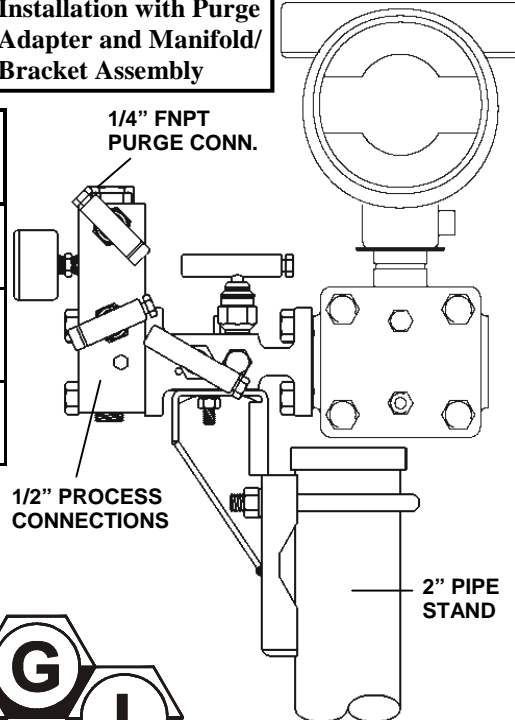

**PGI International, Ltd.**  
Excellence Through Innovation

16101 Vallen Drive—Houston, Texas 77041  
(713) 466-0056 or (800) 231-0233  
www.pgiiint.com

IOM-VM-PAHT  
Rev. 02



## Instructions for High Temperature Purge Adapters

### 1. APPLICATION

PGI's Purge Adapters are designed to keep a constant purge from the instrument to the process. The adapter has a connection for the purge media that goes through a filter to the flow metering element, and then into the process keeping the sensing lines from purging.

### 2. INSTALLATION

The adapters do not come with pressure gauges. We recommend using a 1-1/2" face, 1/4" MNPT, center-back mount gauge. **Operating pressure is limited to 1-1/2 times the pressure rating of pressure gauge installed.**

Installation with Purge Adapter and Manifold/Bracket Assembly

Materials	Pressure & Temperature
Grafoil® Seal with Kalrez® O-Ring	6000 psi @ 200°F 1500 psi @ 600°F
Teflon® Pressure Core® Seal with Kalrez® O-Ring	6000 psi @ 200°F 8000 psi @ 450°F
Teflon® Packed Seal with Kalrez® O-Ring	6000 psi @ 200°F 4000 psi @ 500°F

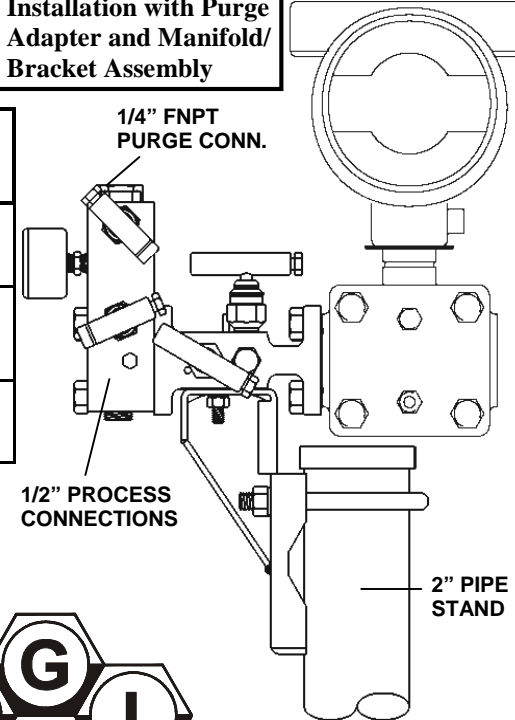

**PGI International, Ltd.**  
Excellence Through Innovation

16101 Vallen Drive—Houston, Texas 77041  
(713) 466-0056 or (800) 231-0233  
www.pgiiint.com

IOM-VM-PAHT  
Rev. 02

### 3. OPERATION

#### Start-Up:

- After the unit has been installed, close the ISOLATION valve on the two/three-valve manifold and open the BYPASS valve on the purge adapter.
- Have TEST valves in the CLOSED position.
- Turn on the purge gas and open the valves at the process connection.
- Open the TEST valves and close the BYPASS valves on the purge block.
- Close the TEST valves on the purge block to check for purge flow (pressure should come up to purge pressure).
- If the purge pressure builds up as it should, open the TEST valves and put the transmitter in service.
- Adjustable Check Valve: Both adjustable check valves should be fully open. When flowing purge gas and the test valves are open, the pressure gauges should display identical pressure. If not, adjust the low check valve to equalize the gauge pressures.

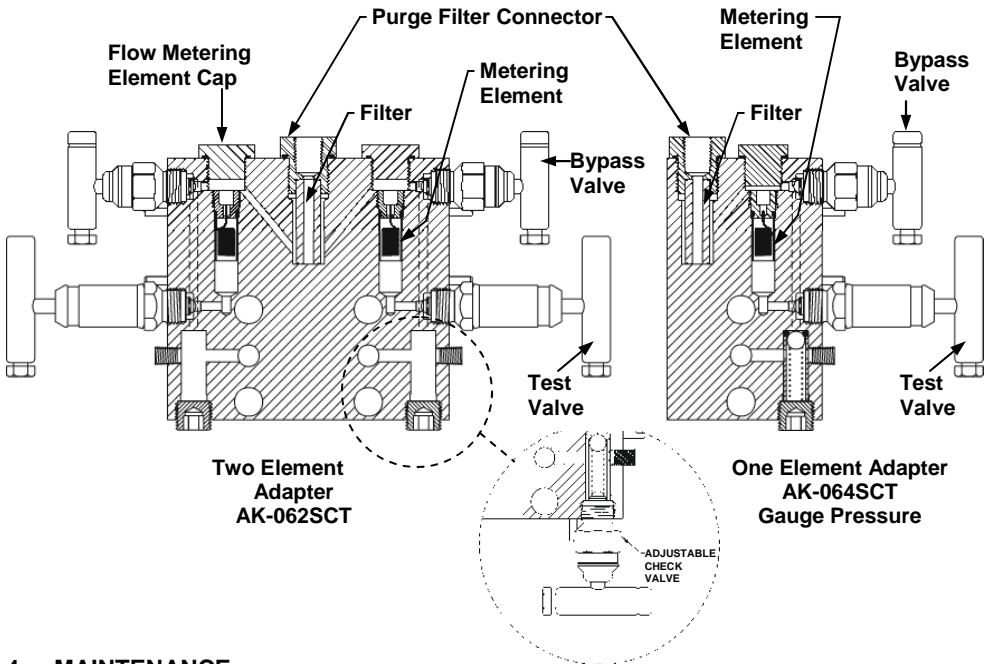

### 4. MAINTENANCE

To test the flow-metering element, close the TEST valve and observe the pressure gauge. It should reach purge pressure. If the pressure does not increase, either the flow-element or the purge filter is plugged.

#### Filter Replacement (to change the filter):

- Shut off the purge gas.
- Close the TEST valves.
- Remove the tubing from the filter connector in the center, top of the purge adapter.
- Remove the purge connector cap.
- Remove and replace the filter.

#### Flow Element Replacement:

- Block in purge gas.
- Close TEST valves.
- Shut off purge gas.
- Remove the cap for the flow-metering unit to be replaced.
- Using a 1/4" Allen wrench, remove the metering element and replace it.

### 3. OPERATION

#### Start-Up:

- After the unit has been installed, close the ISOLATION valve on the two/three-valve manifold and open the BYPASS valve on the purge adapter.
- Have TEST valves in the CLOSED position.
- Turn on the purge gas and open the valves at the process connection.
- Open the TEST valves and close the BYPASS valves on the purge block.
- Close the TEST valves on the purge block to check for purge flow (pressure should come up to purge pressure).
- If the purge pressure builds up as it should, open the TEST valves and put the transmitter in service.
- Adjustable Check Valve: Both adjustable check valves should be fully open. When flowing purge gas and the test valves are open, the pressure gauges should display identical pressure. If not, adjust the low check valve to equalize the gauge pressures.

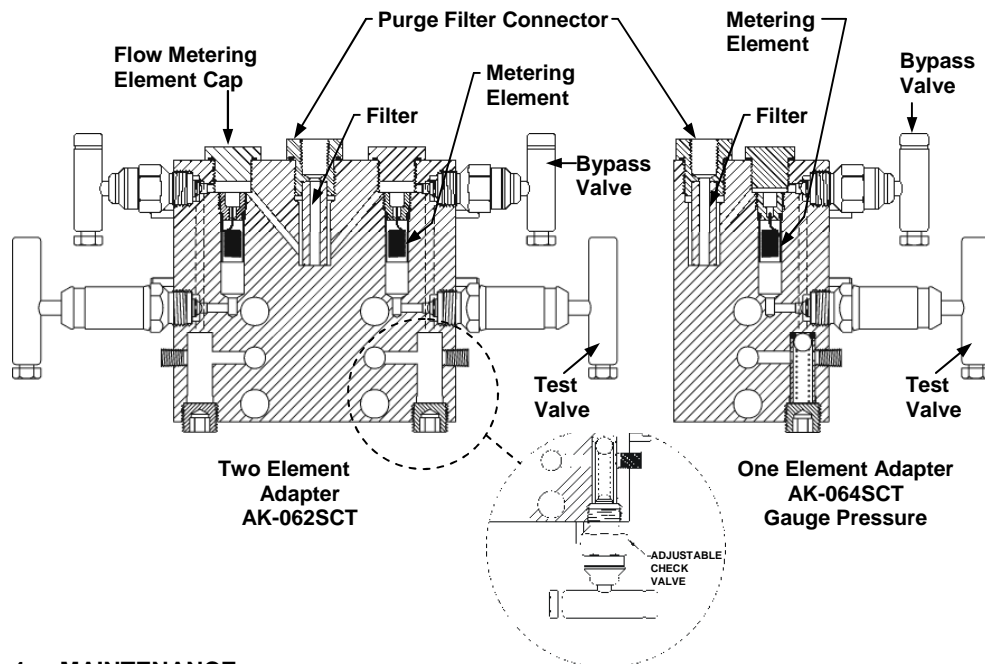

### 4. MAINTENANCE

To test the flow-metering element, close the TEST valve and observe the pressure gauge. It should reach purge pressure. If the pressure does not increase, either the flow-element or the purge filter is plugged.

#### Filter Replacement (to change the filter):

- Shut off the purge gas.
- Close the TEST valves.
- Remove the tubing from the filter connector in the center, top of the purge adapter.
- Remove the purge connector cap.
- Remove and replace the filter.

#### Flow Element Replacement:

- Block in purge gas.
- Close TEST valves.
- Shut off purge gas.
- Remove the cap for the flow-metering unit to be replaced.
- Using a 1/4" Allen wrench, remove the metering element and replace it.