

Effective: July 1, 2018  
Supersedes: December 7, 2015



# Crimper Operator's Manual

## COS-K6 with ACT™ Controller



ENGINEERING YOUR SUCCESS.



## SAFETY PRECAUTIONS



**READ INSTRUCTIONS AND IDENTIFY ALL COMPONENT PARTS BEFORE USING CRIMPER.**

**KEEP HANDS AWAY FROM PINCH POINTS.**

**CONSULT HOSE AND FITTING MANUFACTURER'S SPECIFICATIONS FOR CORRECT MACHINE SETTINGS AND CRIMP MEASUREMENTS.**

**ALWAYS WEAR EYE PROTECTION.**

COMPONENT PARTS IDENTIFICATION -----3

CRIMPER SPECIFICATIONS AND INITIAL SET UP -----4

ACT™ CONTROLLER PANEL -----5

ACT™ CONTROLLER QUICK START GUIDE -----6

COS-K6 MIC MANUAL MICROMETER -----14

DIE SET UP AND INSTALLATION -----15

INITIAL SET UP AND MAINTENANCE -----16

PLC RESET PROCEDURE -----17

TROUBLESHOOTING -----18

EXPLODED PARTS VIEW -----19

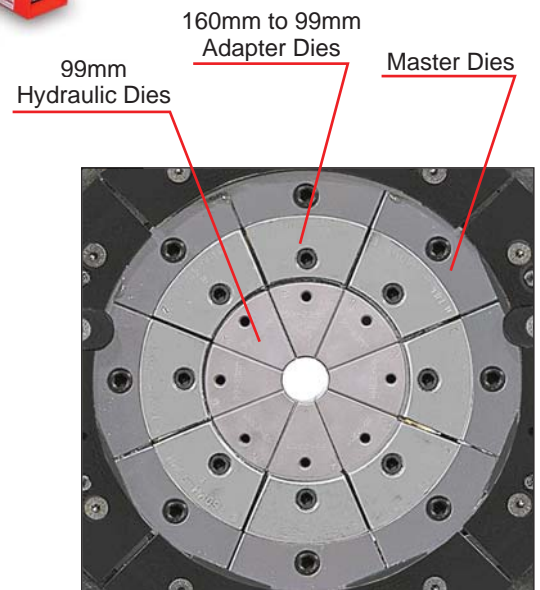
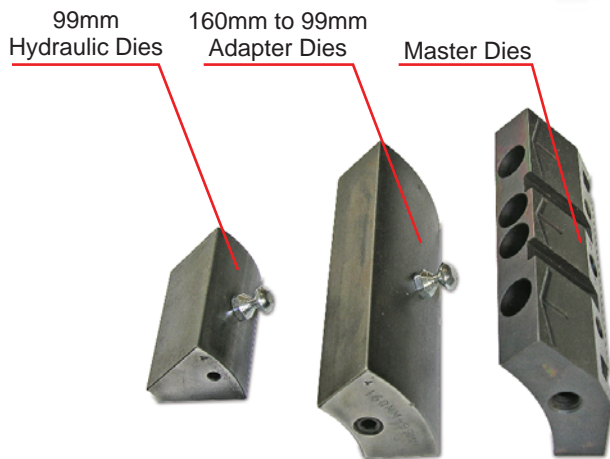
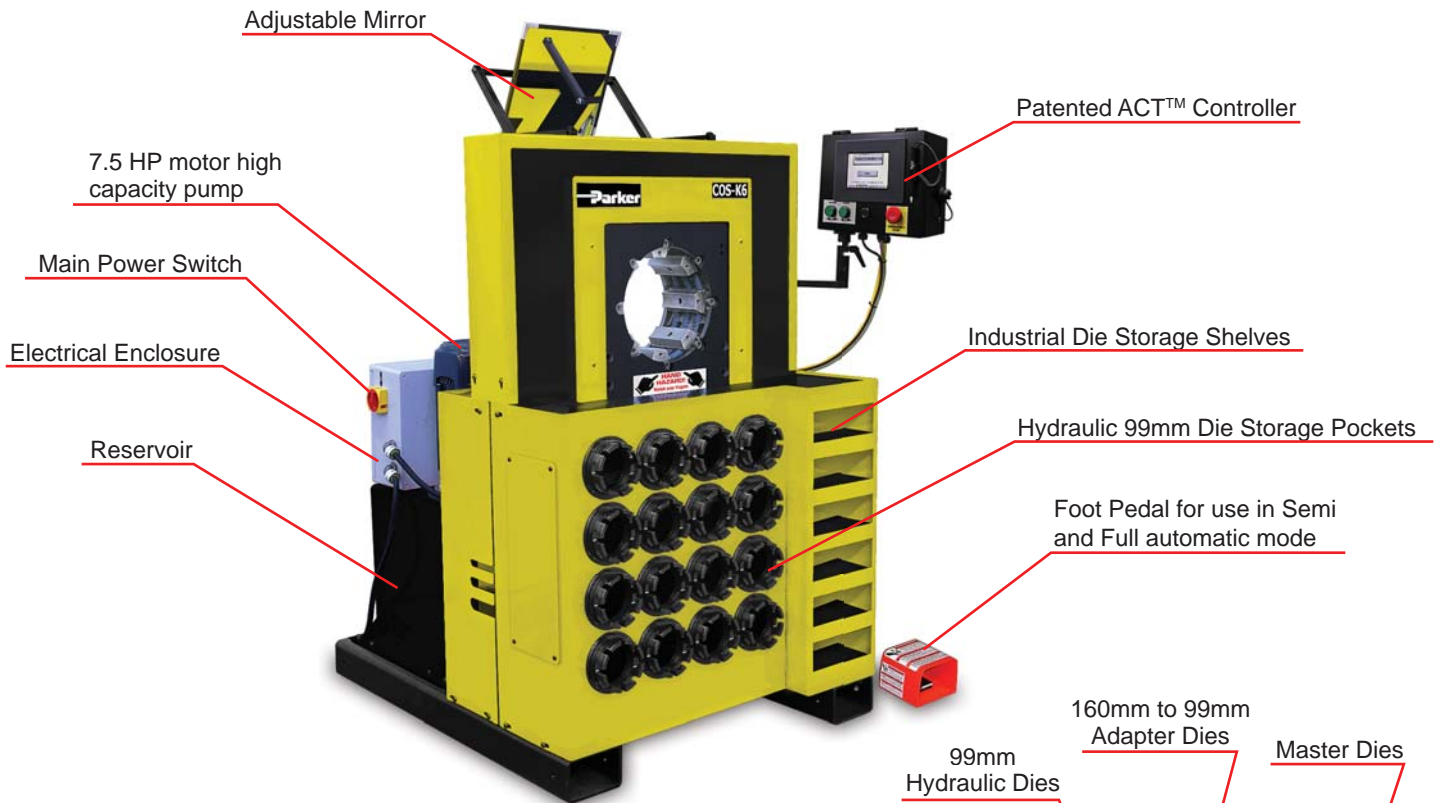

Tank View showing oil fill port and fluid level sight glass



Motor Rotation Arrow



Manual Back Stop

## **SPECIFICATIONS:**

MAX HEAD OPENING W/O DIES	-----286 MM (11.25 IN)
MASTER DIE INSIDE DIAMETER	-----160 MM (6.29 IN)
MAXIMUM DIE OPENING	-----DIE CLOSED DIAMETER + 128 MM (5 IN)
CRIMPER SIZE	-----54 IN WIDE X 49 IN DEEP X 57 IN HIGH
WEIGHT	-----4,000 LBS. (1814 KG)
ELECTRICAL REQUIREMENTS	-----230 VOLT 3 PHASE (STANDARD) ----- 440 VOLT 3 PHASE (OPTIONAL)
MOTOR	-----7.5 HP (2 STAGE PUMP) (STANDARD) -----5 HP (2 STAGE PUMP) SINGLE PHASE (OPTIONAL)
RESERVOIR CAPACITY	-----24 US GAL
OIL TYPE	-----ISO 46 HYDRAULIC OIL
ADAPTER DIES	-----160 MM TO 99 MM
HOSE CAPACITY	-----2 INCH 6 SPIRAL -----6 INCH INDUSTRIAL

## **INITIAL CRIMPER SET UP**

- CHECK RESERVOIR OIL LEVEL WITH SIGHT GLASS ON THE POWER UNIT.
  - CHECK ELECTRICAL CIRCUIT TO BE CERTAIN THAT IT MATCHES THE CRIMPER REQUIREMENTS AS SHOWN ON THE TAG ATTACHED TO THE CRIMPER CORD.
  - MAKE CERTAIN THAT MOTOR ROTATES IN THE DIRECTION OF THE ARROW SHOWN ON THE MOTOR HOUSING.
  - IF MOTOR ROTATION IS INCORRECT REVERSE ANY TWO HOT WIRES IN THE CRIMPER PLUG.
  - ALSO SEE ADDITIONAL INFORMATION ON THE INITIAL SET UP AND MAINTENANCE PAGE.
-

Products covered by all or some of these Patents:  
US 7,383,709; US 8,230,714; EP 1,909,987 and Patents Pending.

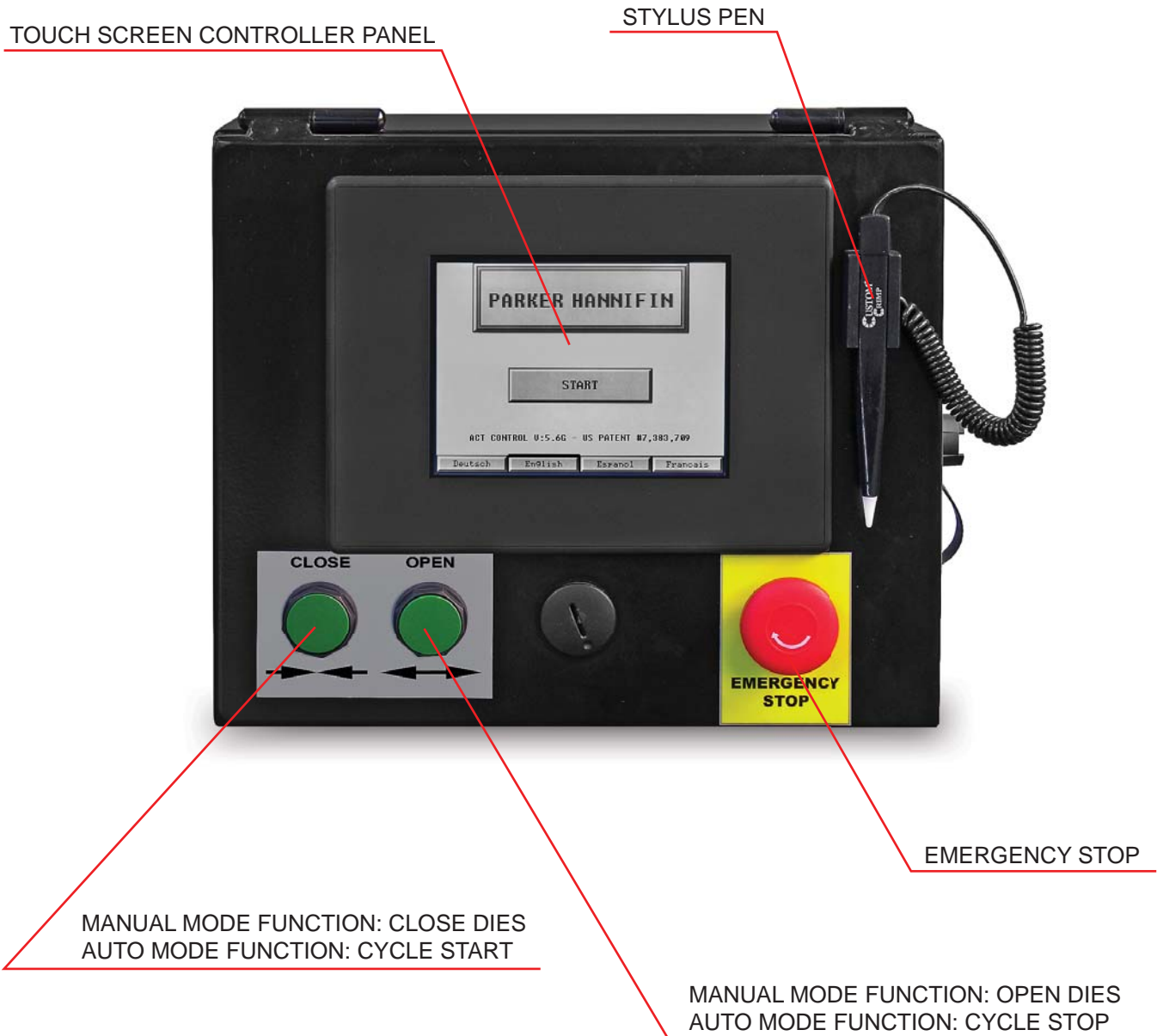

**NOTE:**

**IF THE CRIMPER IS IN MANUAL MODE, THE GREEN OPEN/CLOSE BUTTONS WILL OPEN AND CLOSE THE CRIMPER HEAD.**

**IF THE CRIMPER IS IN AUTO MODE, THE BUTTONS FUNCTION AS CYCLE START AND CYCLE STOP BUTTONS.**

**IF THE CRIMPER IS IN SEMI-AUTO MODE, PRESSING THE FOOT SWITCH OR THE CLOSE BUTTON WILL CLOSE THE CRIMPER HEAD AND RELEASING WILL HALT THE CLOSING ACTION.**

While the ACT™ crimper has the ability to perform a number of fully automatic functions, manual operation is also possible.

To make a manual crimp, two numbers are needed:

- **The closed diameter of the die** (in either in or mm).
- **The finished crimp diameter** (in either in or mm).

That's all you need to know. ACT™ does the rest.



## TO MAKE A MANUAL CRIMP

- Press **START** Button.
- Select **CRIMP TO DIAMETER**.
- Enter the closed diameter of the die set in either in or mm and press **ENTER**.

*Note: for a 25 mm die, enter 2500. ACT™ will add 2 decimal places. for a 1.5 inch die, enter 1500, ACT™ will add 3 decimal places.*

- Enter the finished crimp diameter and press **ENTER**.
- From the **ENTER CRIMP** screen, press the **MANUAL** button to put the crimper in manual mode.
- Confirm that the die and finished crimp diameters are correct and that **MANUAL MODE** is displayed.
- Press and hold the green close button until the crimper stops closing.
- Check the final crimp diameter. If a minor correction is required see **HOW TO MAKE MINOR CORRECTIONS**.

*Tip: Pressing the **CHANGE DIES** button allows the crimper head to be fully opened or closed with the green **OPEN-CLOSE** buttons on the controller front panel. When the **CHANGE DIES** button is blinking the dies can be opened and closed manually without altering any of the crimper settings.*

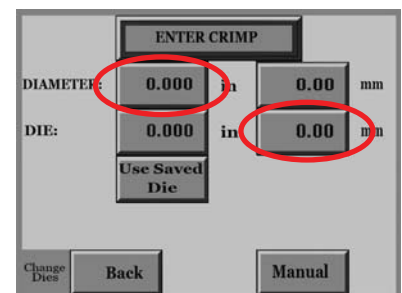
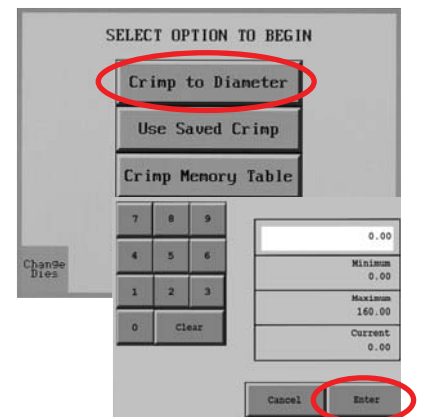
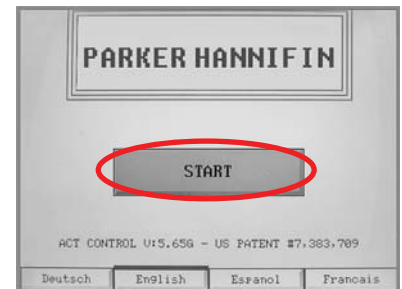

## HOW TO MAKE MINOR CORRECTIONS

Due to variations in hose and fitting tolerances a minor crimp adjustment may be required if the measured diameter of the final crimp is not within the hose and fitting manufacturer's specifications. ACT™ technology makes minor corrections a simple process which requires no addition or subtraction.

*If the finished crimp diameter is not within the required specifications:*

- Press the **ADJUST CRIMP** button.
- Enter the measured diameter of the fitting in either inches or mm
- (*Do not enter the amount of correction*) and press **ENTER**.
- Press **SAVE**.
- Make another crimp and verify that the fitting is within specifications.

### EXAMPLE:

*If the hose and fitting manufacturer specifies that the finished crimp should measure 1.500 to 1.520 and the measured crimp diameter was 1.530, simply enter the measured diameter (1530 - Controller will supply 3 decimal places) and press **SAVE**. The finished crimp diameter can be entered in either in or mm and ACT™ will make the conversion.*

While a single correction will usually bring the hose and fitting into specifications, the process can be repeated as many times as is required.

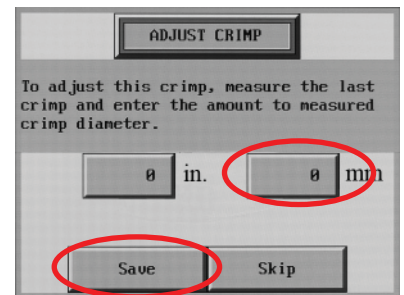
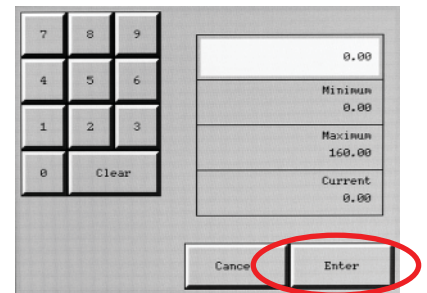
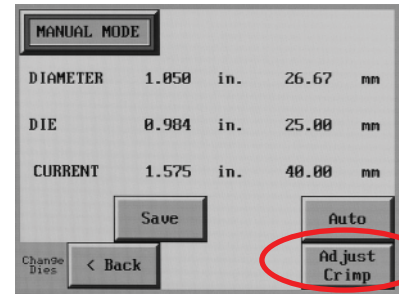

## HOW TO ADD A SAVED DIE:

Up to 50 different dies can be saved in the computer memory. These dies can be recalled in the set up process eliminating the need to re-enter the die size each time.

### TO ENTER A SAVED DIE

- From the **OPTION** screen, press **SETUP MODE**.
- Select **SAVED DIES**.
- Select the save position (1-50) where the die is to be saved and press the **EDIT** button.
- Enter a die description (up to 12 alpha/numeric characters).
- Enter diameter units (inch or metric).
- Enter the closed diameter of the die.
- Press **SAVE** and **EXIT**.

The saved die will now appear on the **SELECTED DIE** screen. From this screen individual dies can be cleared or edited.

### HOW TO RECALL A SAVED DIE

- Select **CRIMP TO DIAMETER**, and from the **OPTION** screen, select **USE SAVED DIE**.
- Select the saved die (1-50) and press **LOAD** and then **OK**. The die parameters will now be used for the crimp process.
- From the **ENTER CRIMP** screen press **MANUAL**.
- The saved die will now be shown on the crimp parameters screen.

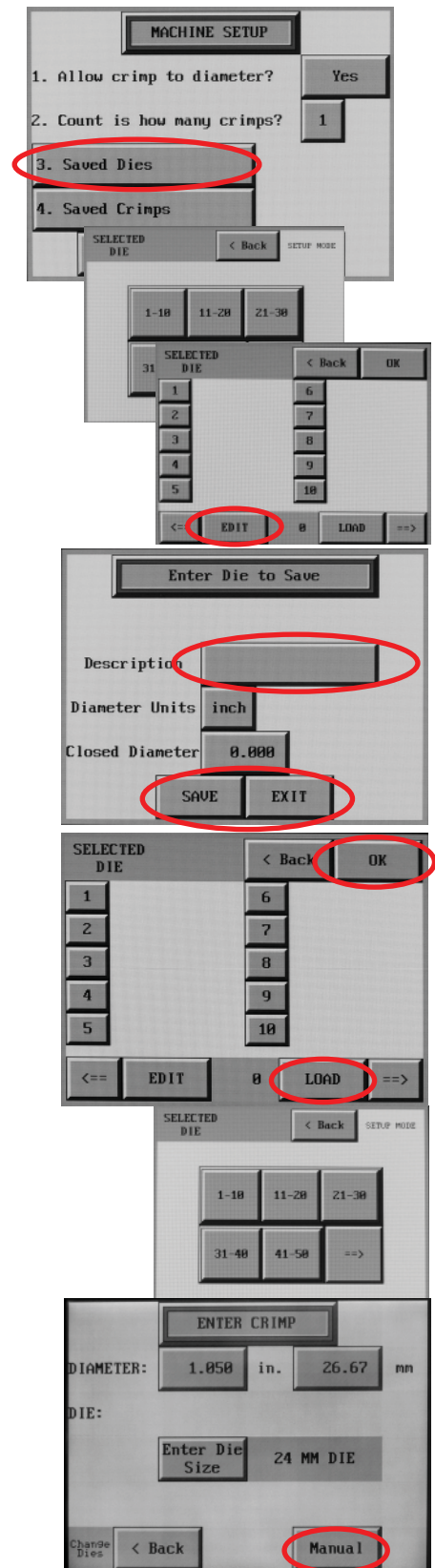

## HOW TO ADD A SAVED CRIMP

- Adjust the die diameter and crimp diameter as required and place the crimper in **MANUAL** mode.
- Press **SAVE**.
- Select a location (1-150) and press **EDIT**.
- Enter a description (up to 12 characters).
- Press **SAVE** and **EXIT**.

The die and crimp setting can now be recalled from the saved location as required

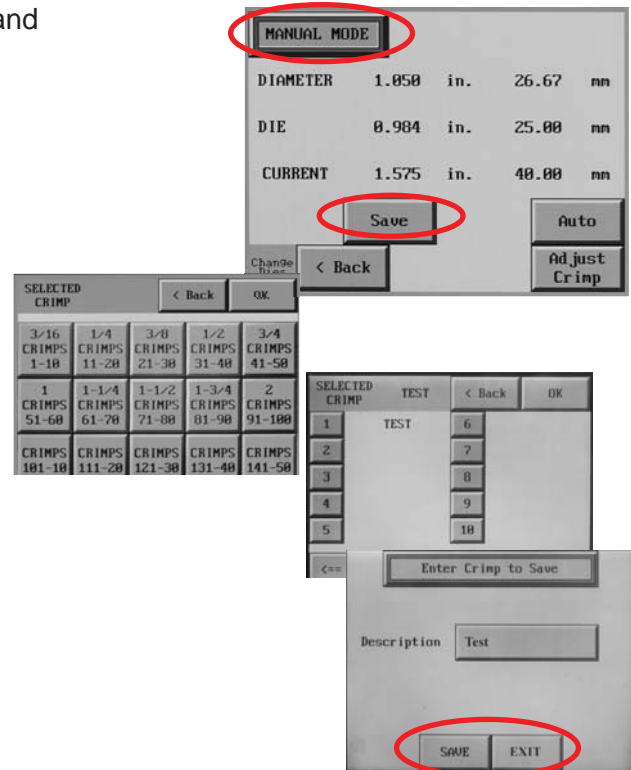

## TO RECALL SAVED CRIMP

- Select **USE SAVED CRIMP** from the option screen.
- Select a previously saved crimp from location 1-150.
- Press **LOAD**.

The saved crimp will appear on the manual screen.

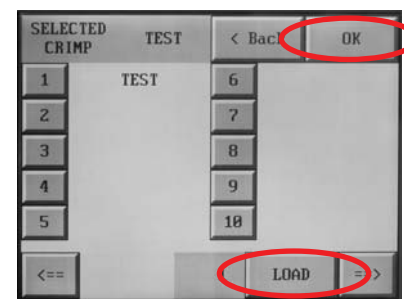
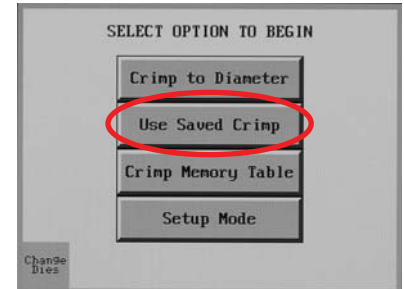

## FULL AUTO MODE

With the crimper in **FULL AUTO** mode additional functions are available:

- The crimper will cycle automatically from the **CRIMP** button on the touch screen, the green **CYCLE START** button on the panel, or the foot switch.
- To set the position to which the dies will retract, close the crimper to the desired retract position prior to pressing the **FULL AUTO** button.
- Pressing the **FULL AUTO** button will toggle the crimper into **SEMI-AUTO** mode. In **SEMI-AUTO** mode, pressing the **FOOT SWITCH** or the **CLOSE** button will close the crimper head and releasing it will cause the head to stop closing. This mode allows the crimper to be jogged into position allowing more precise positioning of a fitting in the dies. Pressing the **SEMI AUTO** button will toggle the crimper back to **FULL AUTO** mode

In **FULL AUTO** mode pressing the foot switch will start the crimp cycle and the dies will stop closing when the crimp cycle is complete.

- The **COUNT** function is activated allowing the operator to monitor the number of crimps made.
- A measurement can be required after a preset number of crimps. See [SET REQUIRED MEASUREMENT](#).

## SET REQUIRED MEASUREMENT

- Press the **PRODUCTION** button.
- Determine if 1 or 2 crimps will count as a crimp.
- Toggle the **CRIMP ADJUSTMENT REMINDER** to **ON**.
- Set the **COUNTS BETWEEN CRIMP MEASUREMENTS** to the desired number and press **OK**.
- At the set interval, the **ADJUST CRIMP** screen will come up and the operator will be asked to measure the last crimp and enter a correction if required.

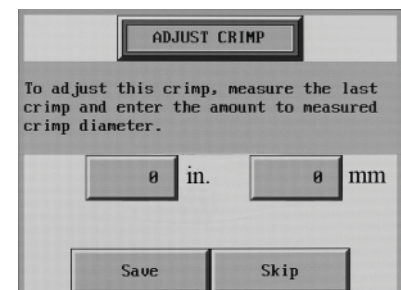
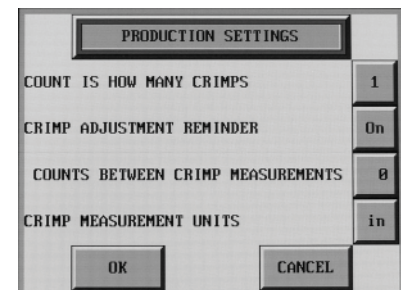
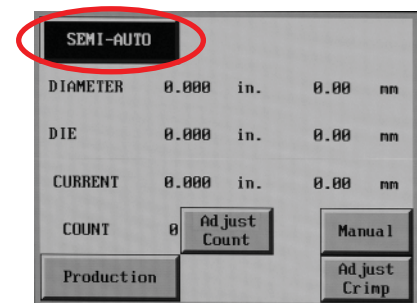
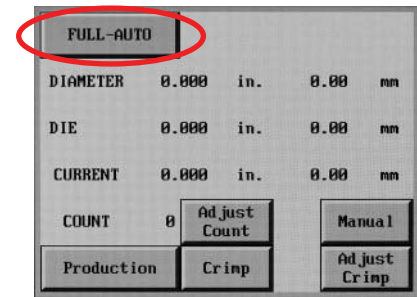

## ADJUST CRIMP COUNT

If a production operation is interrupted for some reason, it is possible to reset the counter to where the operation was at the point of interruption.

- Press the Adjust Count button from the auto crimp screen.
- Press the Crimp Counter and reset the count to the desired point.

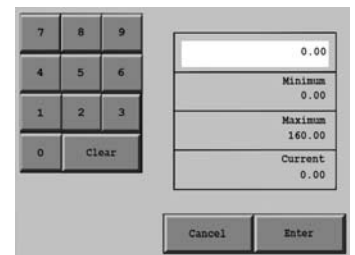
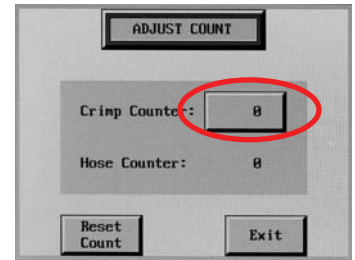
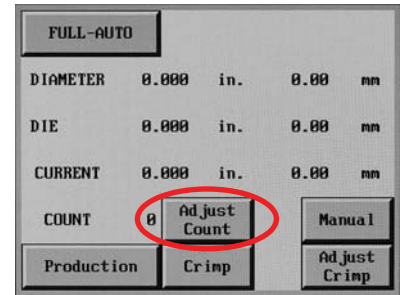

## ACT™ ADDITIONAL FEATURES

- Additional features and functions of the ACT™ controller can be accessed by pressing the **MORE** button on the **MACHINE SETUP** screen.
- When “Allow Crimp to Diameter” is set to “**YES**”, all of the adjustment functions of the crimper are available. When “Allow Crimp to Diameter” is set to “**NO**” only the settings entered as a saved crimp can be used.
- English or Spanish language options are available.
- The “Use Pressure Compensation” is set to “**YES**” for all crimpers equipped with a pressure transducer. A security code is required to turn this function on or off.

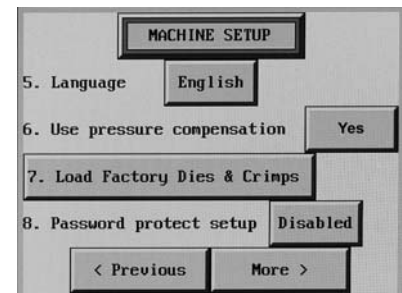

## ACT™ ADDITIONAL FEATURES

### Pre-Loaded Crimp Specifications

In addition to the ability to store up to 50 user entered dies and 150 user entered crimp settings, the ACT™ Controller has the capability of accepting pre loaded manufacturer's crimp specifications. Parker does not maintain these specifications as they are proprietary to the individual hose and fitting manufacturer. If, however, your ACT™ Controller was pre loaded with a manufacturer's crimp specifications or if they are available to you, they are accessed in the following manner:

- Press the **Crimp Memory Table** Button.
- Press the access button to bring up the stored crimp specifications.
- Scroll through the crimp specifications to select the correct one. The right hand rocker button moves through the crimp specs one line at a time and the left hand rocker button moves one screen at a time.
- When the correct crimp specification is selected, press the highlighted selection and then the Load button and select OK to write the data to the ACT™ Controller.
- This will bring up the familiar crimp screen and the crimper can then be operated in the normal manner.

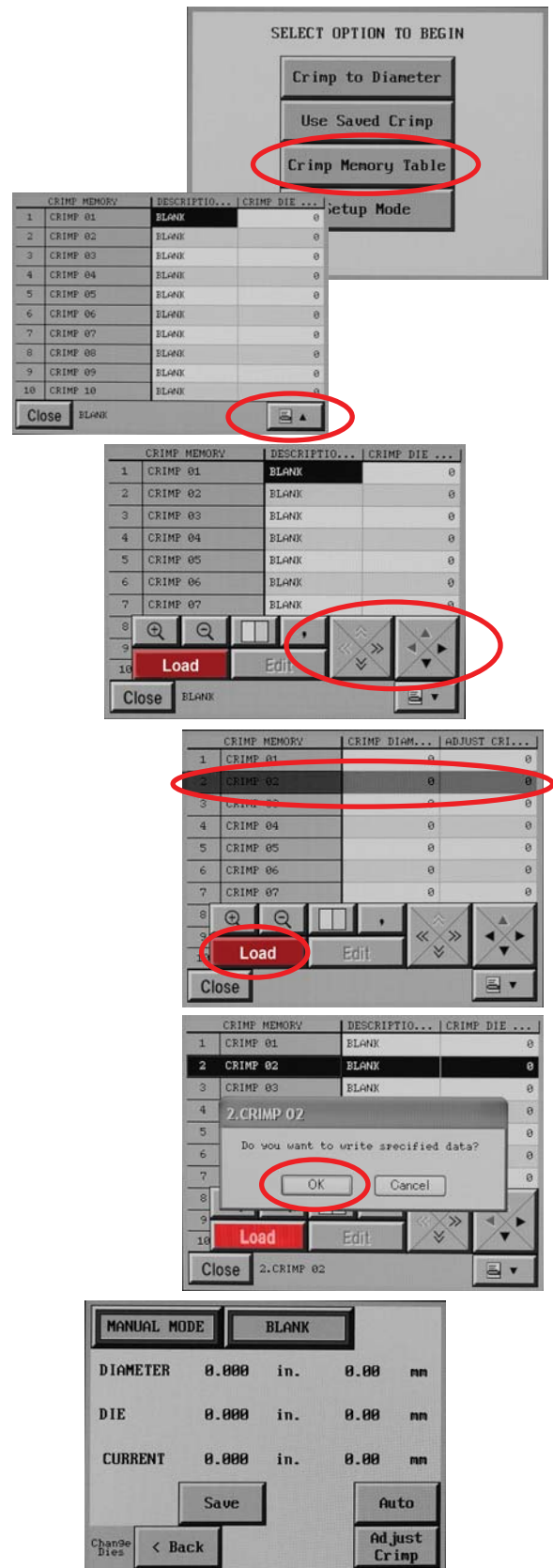

The Industrial Hose Crimp Calculator is part of the ACT™ controller package on many Parker® crimpers capable of crimping industrial hoses. With a few simple measurements, it takes the guess work out of industrial hose crimping and eliminates the need for charts and graphs.

*Note: Not all ACT™ controllers have the Industrial Crimp Calculator software. Contact your sales specialist for information on a specific crimper.*



- Press the **CRIMP TO DIAMETER** button
- Press the **INDUSTRIAL CRIMP** Button
- Press **MEASURE**
  - If the hose diameter is known or a pi tape is being used, enter the hose O.D.
  - If hose O.D. is not known, press **MEASURE** for wall thickness options
- Measure the wall thickness of the hose. Press the right arrow and take 2 more measurements of the hose wall thickness. The Industrial Crimp Calculator will average the three measurements.
- Enter the stem diameter of the fitting. For example: If the stem diameter is 4 inches, you would enter 4000 and the ACT™ controller would supply the decimal place.
- Measure and enter the wall thickness of the ferrule
- Next enter a compression factor. While this can vary depending upon the specific hose and manufacturer, the following guidelines are a starting point:

Standard Industrial hose (approximately 1/4 inch wall thickness): 22%

Standard lay flat hose: 11%

*Note: Contact your hose and fitting manufacturer for the compression factor to use on a specific hose and ferrule.*

- Press **PROCESS** and enter the die diameter if you have not already done so.
- Select and install the correct die set for the combination of hose and fitting being crimped.
- Press **MANUAL** and proceed to crimp the hose.

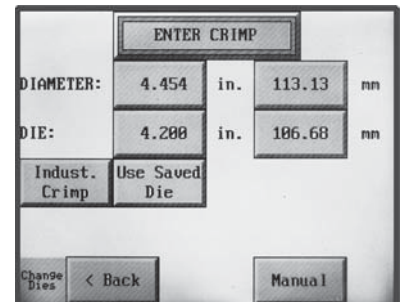
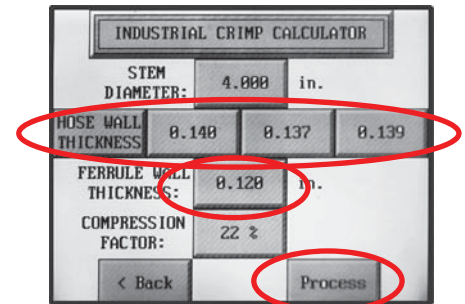
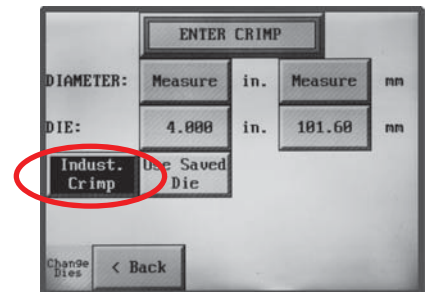
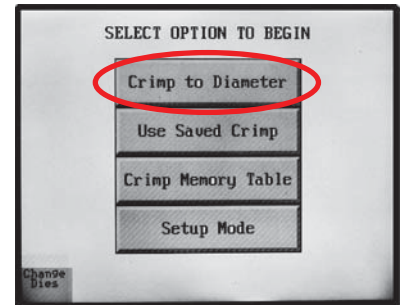

The COS-K6 MIC is available with a manual micrometer in place of the ACT™ controller. Set up and adapter and die installation are identical to the COS-K6 ACT model.

The micrometer is a direct reading metric micrometer. With the micrometer set at zero, the die set will close to the fully closed diameter stamped on the face of the die. The number set on the micrometer will be the amount **ABOVE** the closed diameter of the die at which the dies will stop closing.

**Example:**

*If the required final crimp diameter for the hose and fitting being crimped is 65.5 mm, the correct die set to use would be a 63 mm die set. The micrometer would be set at 2.5 mm as shown, and the final crimp diameter would be 65.5 mm (63 mm-closed die diameter plus 2.5 mm).*

Opening and closing of the crimper head is controlled with the foot switch. Press and hold the foot switch until the crimp is complete and the dies stop closing.

Always check the hose and fitting with a caliper to be certain that the final crimp diameter is in accordance with the hose and fitting manufacturers specifications.

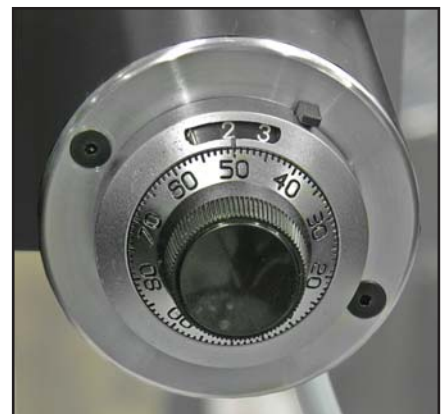

## ADAPTER DIE INSTALLATION

160 mm to 99 mm Adapter Dies are furnished with the crimper. Adapter dies are held in place by the locking screws as shown in the photo. Hydraulic dies can either be installed manually or with the die removal tool as shown. (84 mm adapter dies are also available).

*The I.D. of intermediate adapter dies must match the O.D. of the corresponding adapter die or hydraulic die or accurate crimps can not be made.*



## HYDRAULIC DIE INSTALLATION

- Install the 160 mm to 99 mm Intermediate Adapter Dies as shown making certain that the Intermediate Adapter Die I.D. matches the Hydraulic Die O.D.
- Install the Hydraulic Dies with the quick change tool as shown.
- The die size stamped on the face of the die should face toward the operator.

*Press the **CHANGE DIES** button on the ACT™ controller to easily open and close the master dies without affecting crimper settings.*

- Align the studs of the Hydraulic Dies with the holes in the Adapter Dies and with the crimper in die change mode **SLOWLY** close the crimper head on the die set.
- Bring the crimper head to a fully closed position and remove the die insertion tool.



The dies may also be inserted manually with the crimper head in the fully open position.

Proceed to the ACT™ operating instructions to set up the crimper for the hose and fitting being crimped, or adjust the manual micrometer to the correct crimp diameter.

For Hydraulic Die removal, place the crimper in die change mode and bring the crimper head to the fully closed position. Insert the quick change tool and open the crimper head releasing the Hydraulic Dies from their spring retention holes.



Check to be certain that the motor rotates in the direction of the arrow shown on the motor housing and that the voltage is correct as indicated on the tag attached to the plug. If motor rotation is opposite of the direction of the arrow, reverse any two hot wires in the electrical plug.

Damage to the pump can result if the motor does not rotate in the correct direction.

Check the oil level in the sight glass on the tank. 24 U.S. gallons of ISO 46 hydraulic oil are required to completely refill the tank.

Oil can be drained from either of the two ports at the bottom of the tank.

An additional oil cooler, while not normally required, can be plumbed into the two ports at the rear of the tank.



Flush Fitting Adapter

## LUBRICATION

Lubricate the crimping head after each 100 crimping cycles or at the start of each shift if the crimper is used in a production setting. Use only a high pressure moly-di-sulfide grease and a grease gun with a flush fitting adapter.

***Failure to lubricate the crimper can cause premature failure, loss of accuracy and may result in costly repairs to the crimper.***

Bring the master dies to the fully closed position, and lubricate the master dies through the 8 holes in the protective plates as shown in Photo "A".

With the dies still in the fully closed position grease the fittings visible through the two top grease holes in the face of the crimper as shown in Photo "B".

Bring the master dies to the fully open position and lubricate the crimper through the fittings visible through the two bottom grease holes in the face of the crimper as shown in Photo "C".

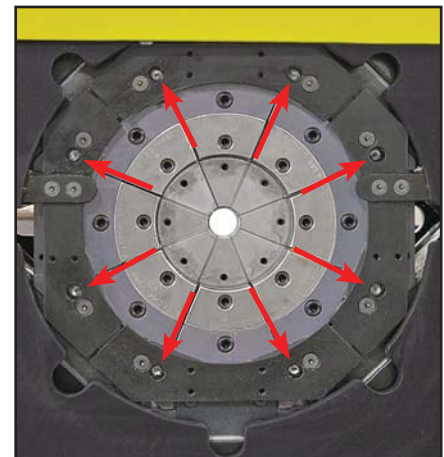

PHOTO A

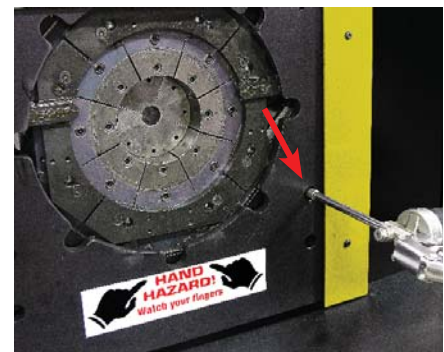

PHOTO B

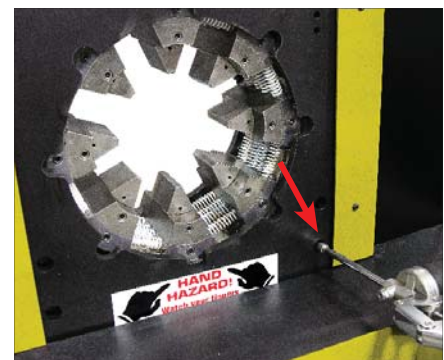
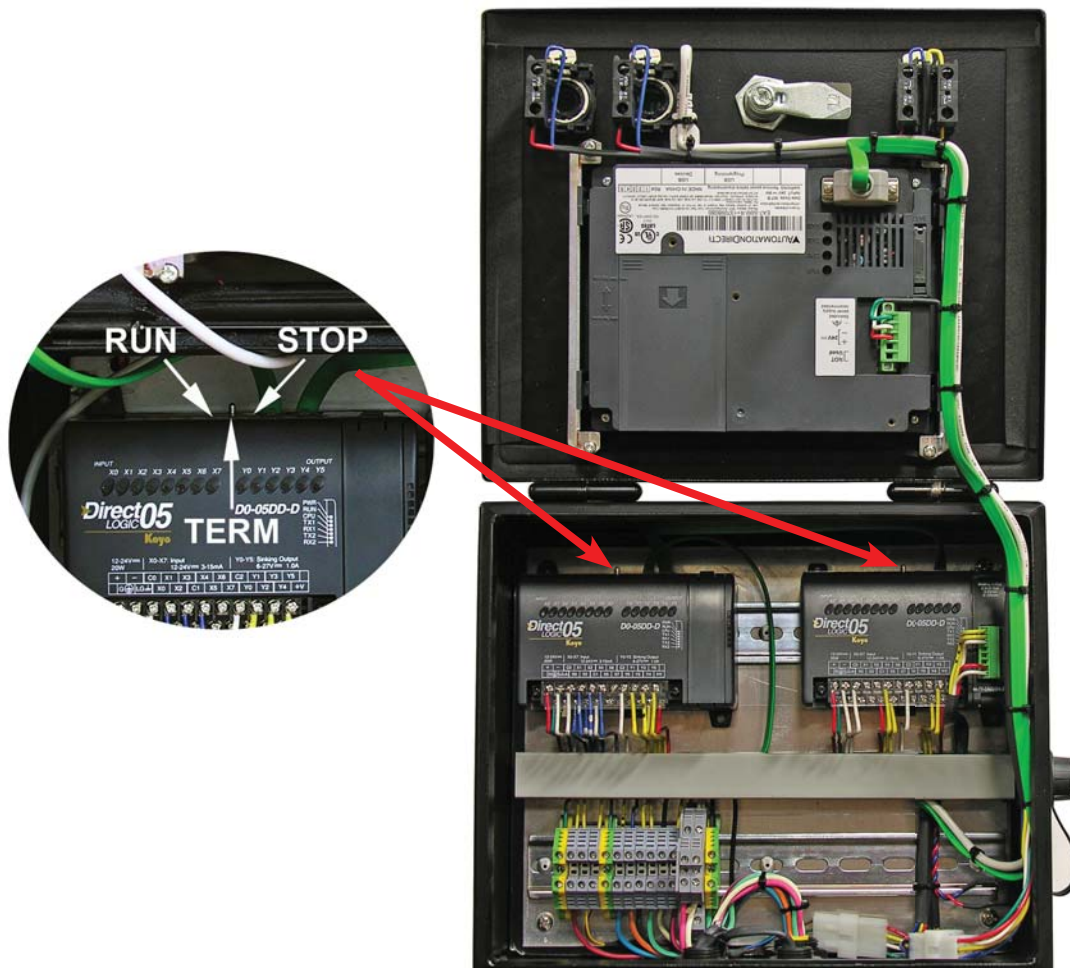

PHOTO C

The PLC (Programmable Logic Controller) requires a relatively constant source of electrical power. Power surges, outages or drops in power can cause the PLC to lose its settings. This may result in missing or misplaced information on the controller screen.

**Resetting the PLC to its original settings is a simple procedure.**

- Turn the main power switch to OFF.
- Open the front of the Control Panel.
- Power up the crimper from the main power switch. The crimper must be powered on during the PLC reset procedure.
- Move the three position toggle switch on top of the PLC right to the STOP position and then left to the RUN position.
- Return the toggle switch to the center TERM position.
- Repeat for the other PLC Unit.
- Turn the main power switch to OFF and replace the front panel.
- The PLC and the crimper should now operate normally.



## **PROBLEM: CRIMPER WILL NOT RUN AT ALL**

- Check the E-Stop switch to be certain that it is not depressed. A slight twist is required to release switch after it has been depressed.
- PLC (Programmable Logic Control) must be reset. See instructions on the previous page.

## **PROBLEM: CRIMPER RUNS BUT IS SLOW OR NON-FUNCTIONAL**

- Check supply voltage to see that it matches the voltage specified on the tag attached to the crimper. Many performance problems are the result of low voltage or inadequate electrical service.
- Check motor rotation and be certain that the motor rotates in the direction of the arrow on the motor housing. For three phase units rotation can be reversed by switching any two wires in the plug.

## **PROBLEM: CRIMPER WILL CLOSE ON FITTING BUT DOES NOT DEVELOP POWER TO COMPLETE THE CRIMP**

- Check oil level. Position dies to the fully open position and check oil sight gage in rear of machine. Be sure the oil level is in the middle of the sight glass. Use ISO 32 or 46 weight hydraulic oil.

## **PROBLEM: CRIMPER WILL NOT OPEN TO RETRACT POSITION IN AUTO MODE**

- Retract position must be at least 3 mm larger than the final crimp diameter.

*If problems persist contact Customer Service for additional troubleshooting assistance.*

---

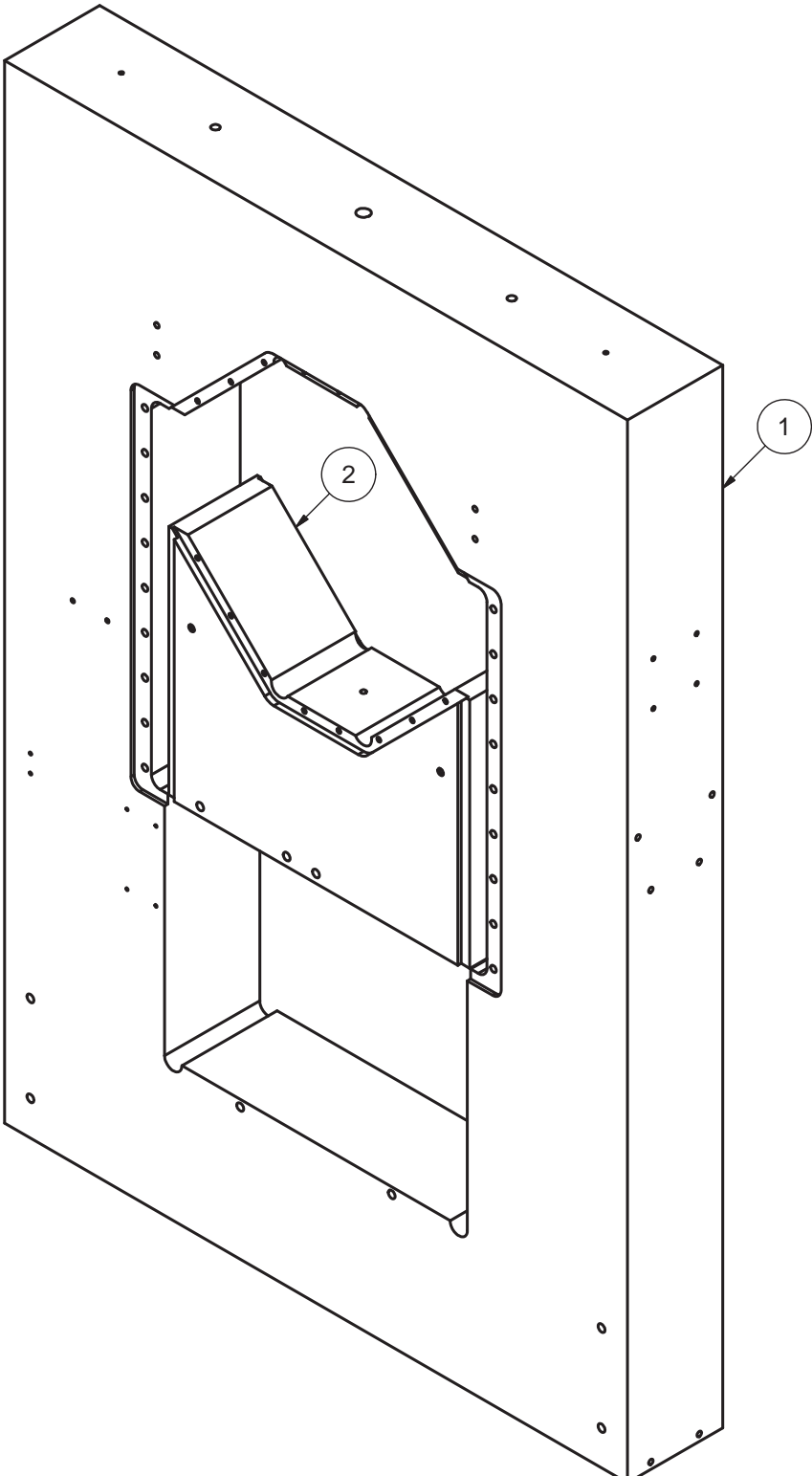

CC 650 Frame and Sliding V Block (103948)			
ITEM	PART NUMBER	DESCRIPTION	QTY
1	103323	CC600 Frame	1
2	103324	CC600 Sliding V Block	1

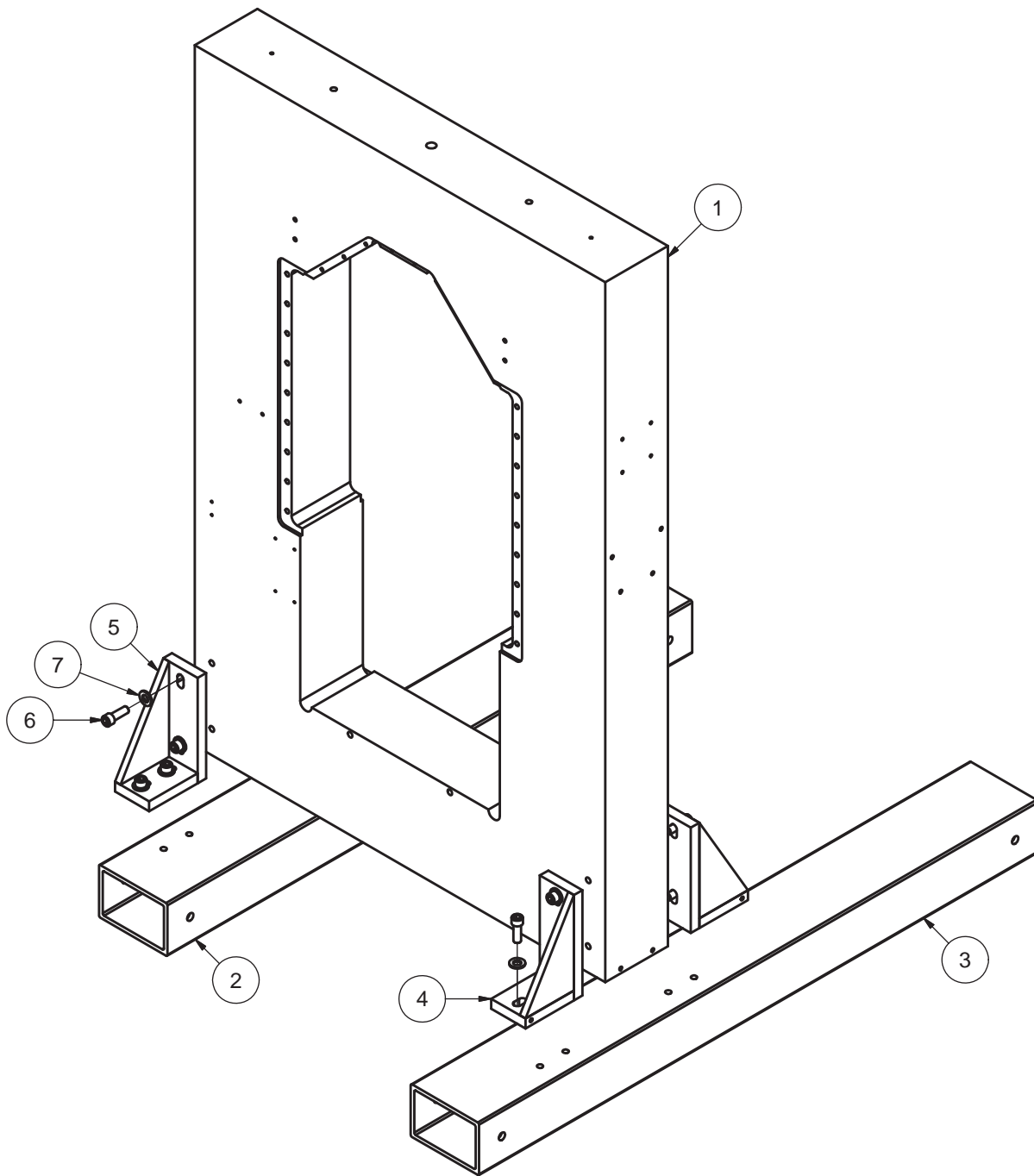

CC 650 Feet and Leg Assembly (103947)			
ITEM	PART NUMBER	DESCRIPTION	QTY
1	103323	CC600 Frame	1
2	103377	CC600 Left Foot	1
3	103378	CC600 Right Foot	1
4	103376-R	CC600 Right Leg Assembly	2
5	103376-L	CC600 Left Leg Assembly	2
6	MTS15612	M12 X 35 SHCS	16
7	WS23558	1/2 Flat Washer	16

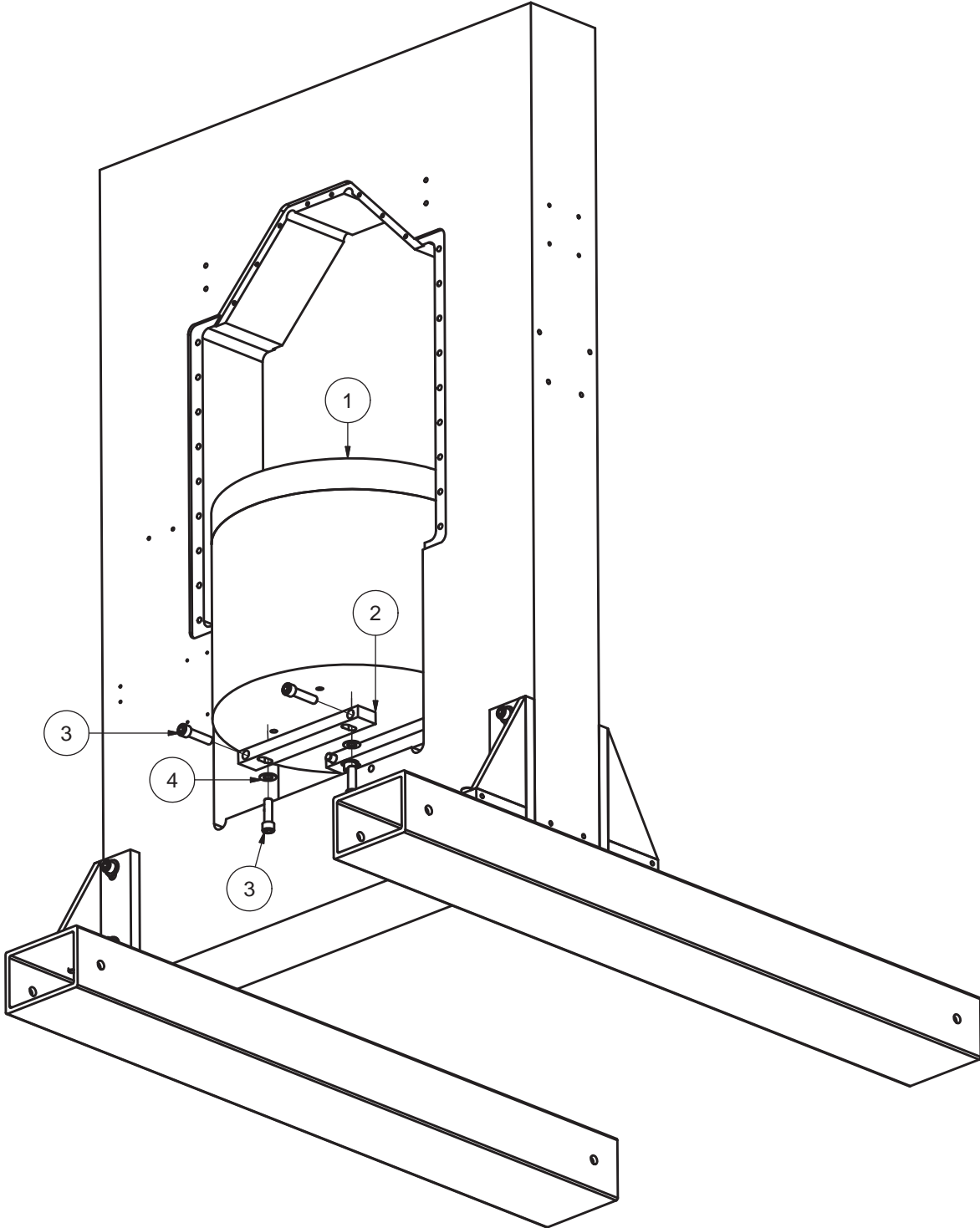

CC650 Cylinder Installation Assembly (103949)			
ITEM	PART NUMBER	DESCRIPTION	QTY
1	103913	CC 650 Cylinder Assembly	1
2	103935	Cylinder Mounting Bracket	2
3	MTS15615	M12 X 50 SHCS	8
4	WS23558	1/2 Flat Washer	4

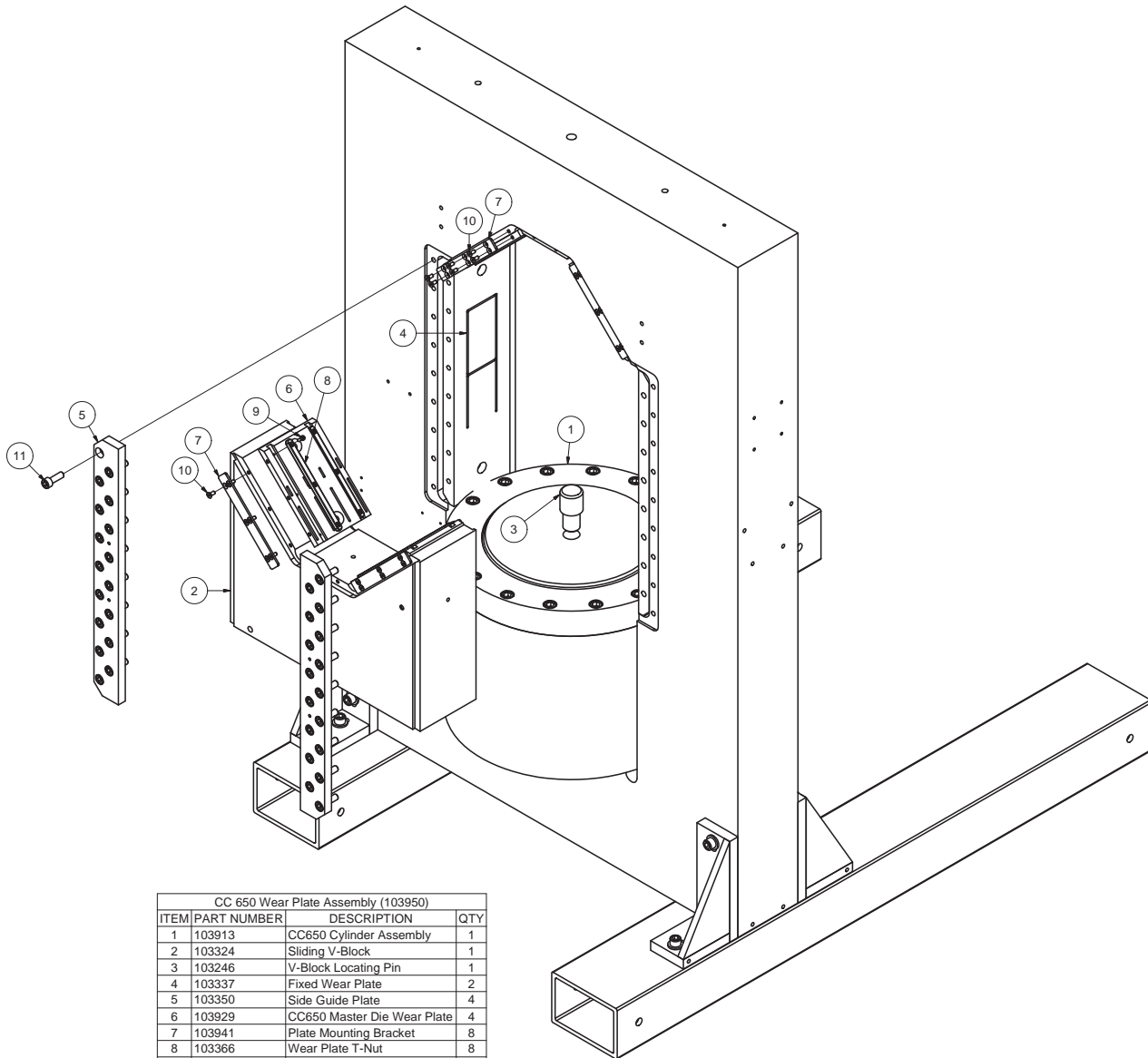

CC 650 Wear Plate Assembly (103950)			
ITEM	PART NUMBER	DESCRIPTION	QTY
1	103913	CC650 Cylinder Assembly	1
2	103324	Sliding V-Block	1
3	103246	V-Block Locating Pin	1
4	103337	Fixed Wear Plate	2
5	103350	Side Guide Plate	4
6	103929	CC650 Master Die Wear Plate	4
7	103941	Plate Mounting Bracket	8
8	103366	Wear Plate T-Nut	8
9	MTS15499	M4 X 12 SHCS	24
10	91294A210	M5 X 12 FHCS	48
11	MTS15583	M10 X 30 SHCS	68

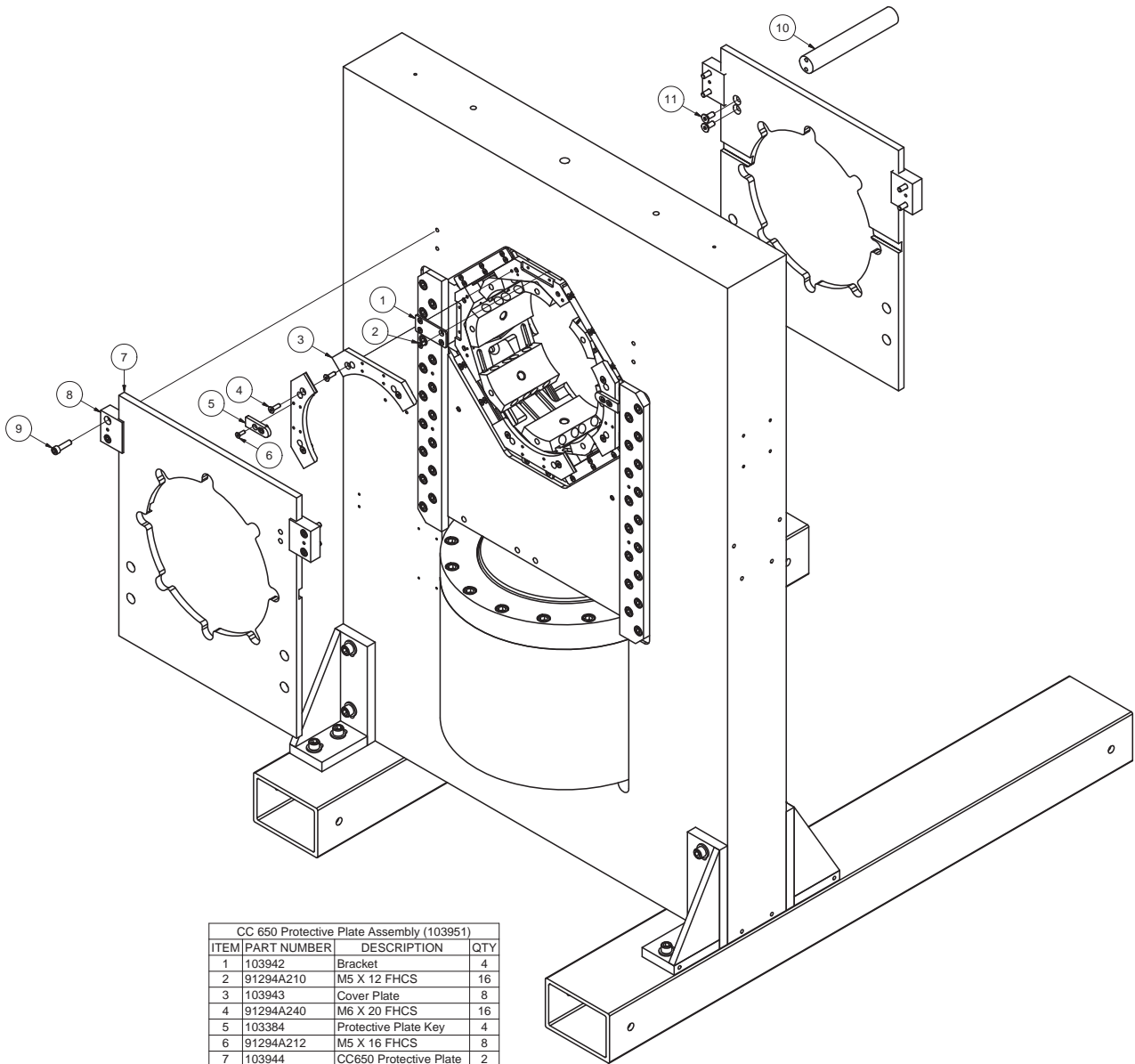

CC 650 Protective Plate Assembly (103951)			
ITEM	PART NUMBER	DESCRIPTION	QTY
1	103942	Bracket	4
2	91294A210	M5 X 12 FHCS	16
3	103943	Cover Plate	8
4	91294A240	M6 X 20 FHCS	16
5	103384	Protective Plate Key	4
6	91294A212	M5 X 16 FHCS	8
7	103944	CC650 Protective Plate	2
8	103387	Alignment Tab	4
9	MTS15554	M8 X 30 SHCS	8
10	103391	Backstop Mount	1
11	91294A284	M8 X 20 FHCS	2

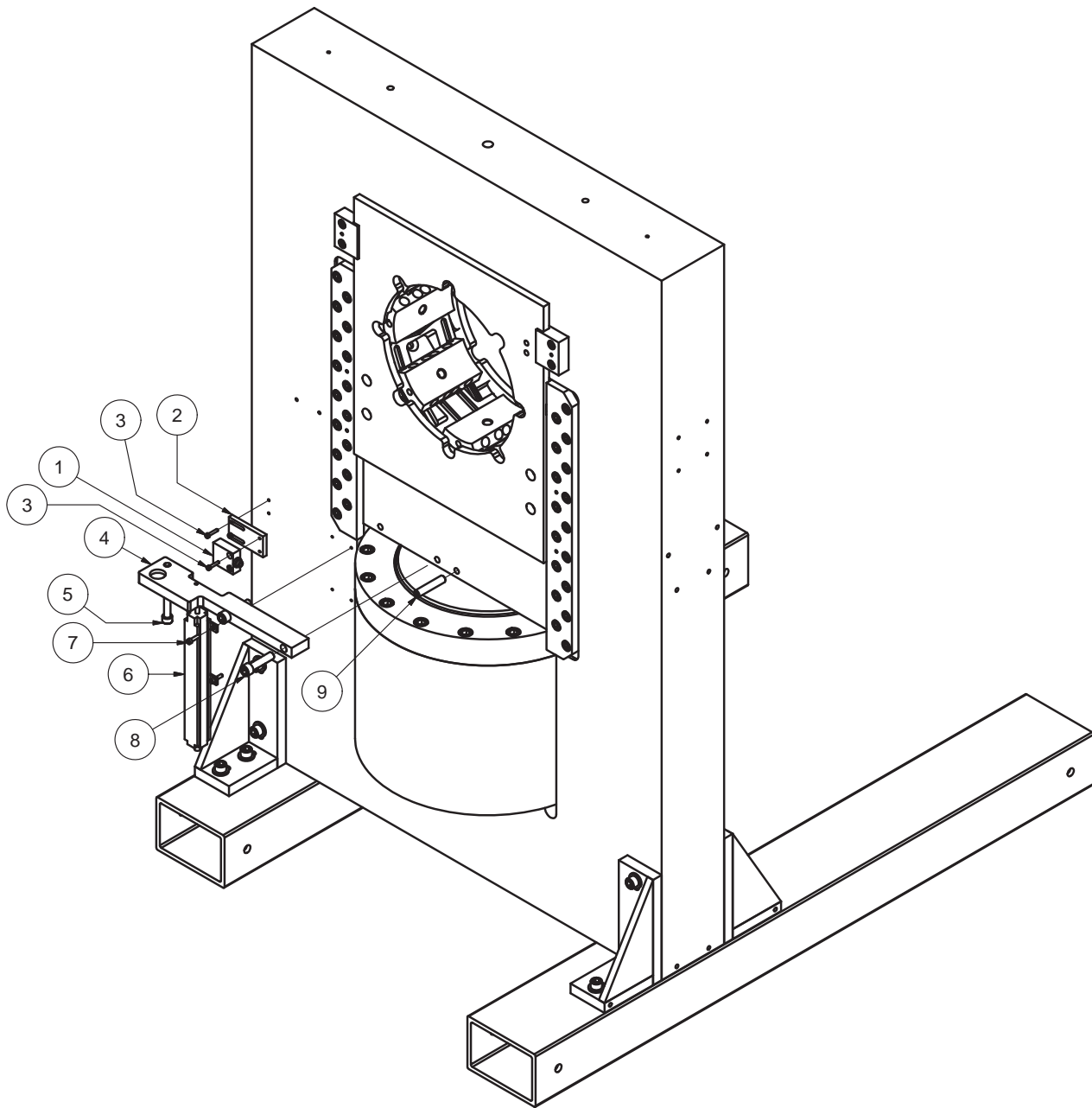

CC600/650 Potentiometer/Limit Switch Assembly (103952)			
ITEM	PART NUMBER	DESCRIPTION	QTY
1	103473	Roller Limit Switch	1
2	103349	Limit Switch Adjustable Bracket	1
3	SKC2095	10-24 X 3/4 SHCS	4
4	103381	Potentiometer Bracket	1
5	91290A548	M10 X 100 SHCS	1
6	103472	CC600/1000 Linear Potentiometer	1
7	103472	M4 X 20 SHCS	4
8	MTS15615	M12 X 50 SHCS	2
9	91390A181	M12 X 70 Set Screw	1

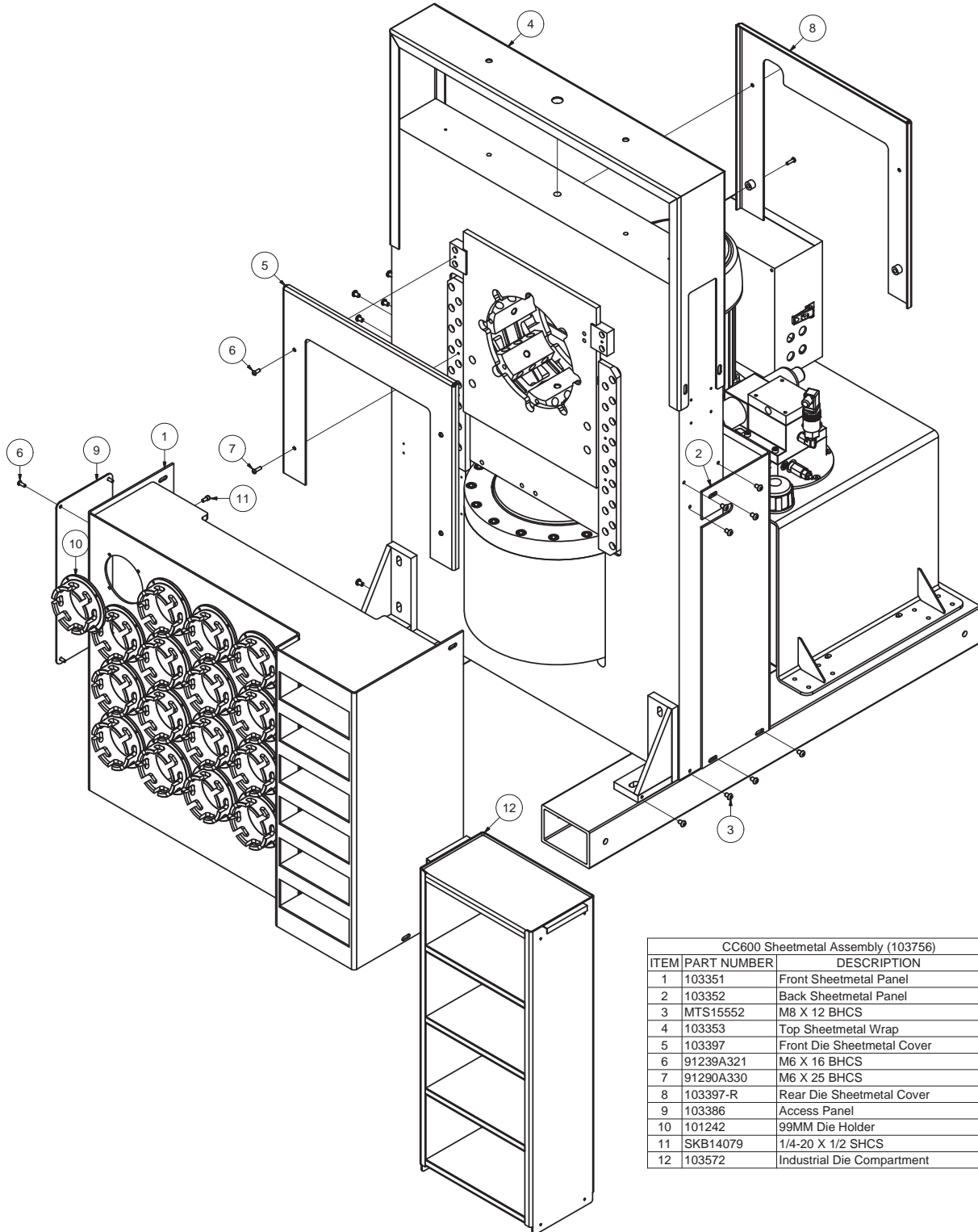

CC600 Sheetmetal Assembly (103756)			
ITEM	PART NUMBER	DESCRIPTION	QTY
1	103351	Front Sheetmetal Panel	1
2	103352	Back Sheetmetal Panel	1
3	MTS15552	M8 X 12 BHCS	16
4	103353	Top Sheetmetal Wrap	1
5	103397	Front Die Sheetmetal Cover	1
6	91239A321	M6 X 16 BHCS	8
7	91290A330	M6 X 25 BHCS	4
8	103397-R	Rear Die Sheetmetal Cover	1
9	103386	Access Panel	1
10	101242	99MM Die Holder	16
11	SKB14079	1/4-20 X 1/2 SHCS	64
12	103572	Industrial Die Compartment	1

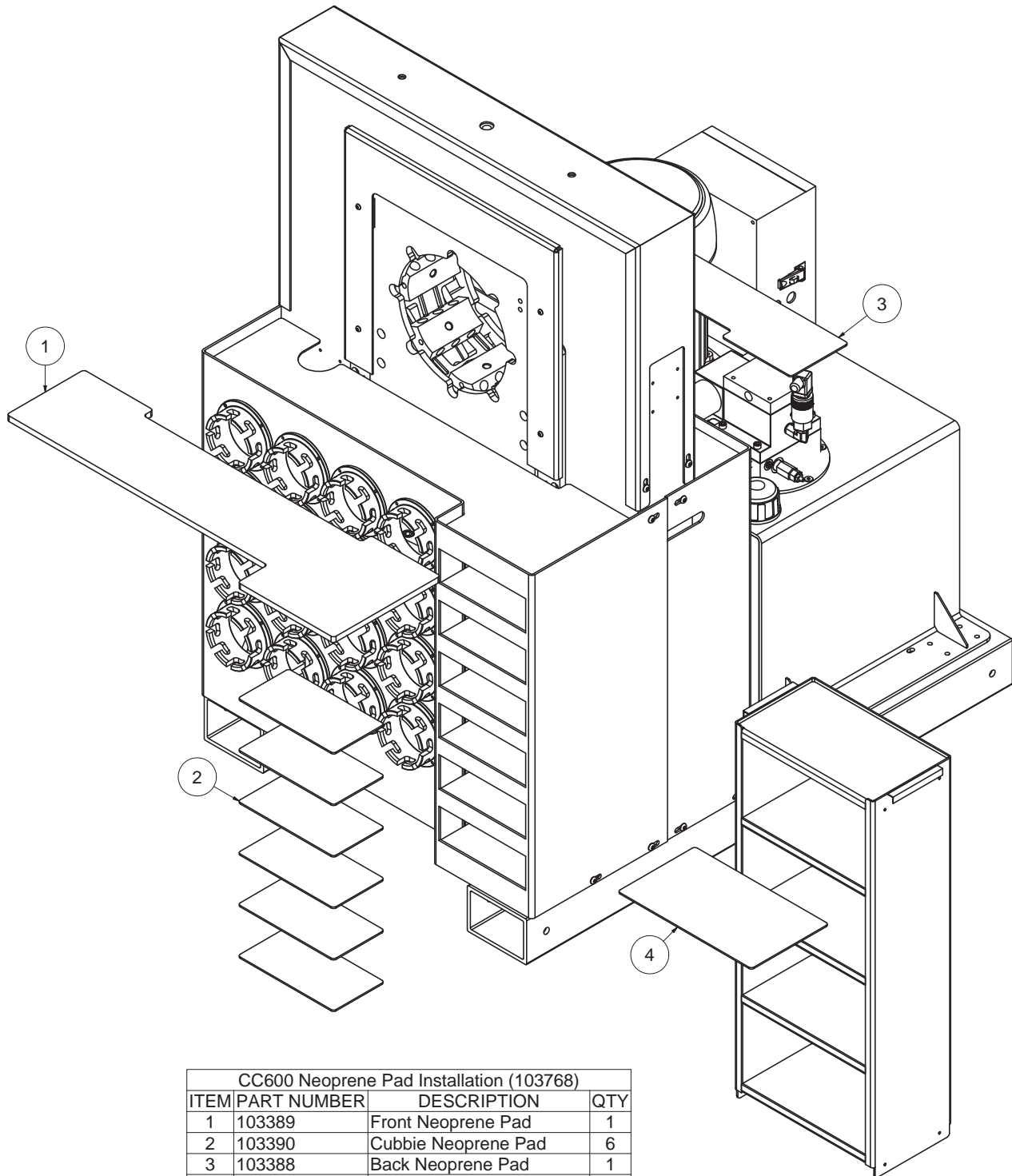

CC600 Neoprene Pad Installation (103768)			
ITEM	PART NUMBER	DESCRIPTION	QTY
1	103389	Front Neoprene Pad	1
2	103390	Cubbie Neoprene Pad	6
3	103388	Back Neoprene Pad	1
4	103573	Industrial Die Holder Mat	5

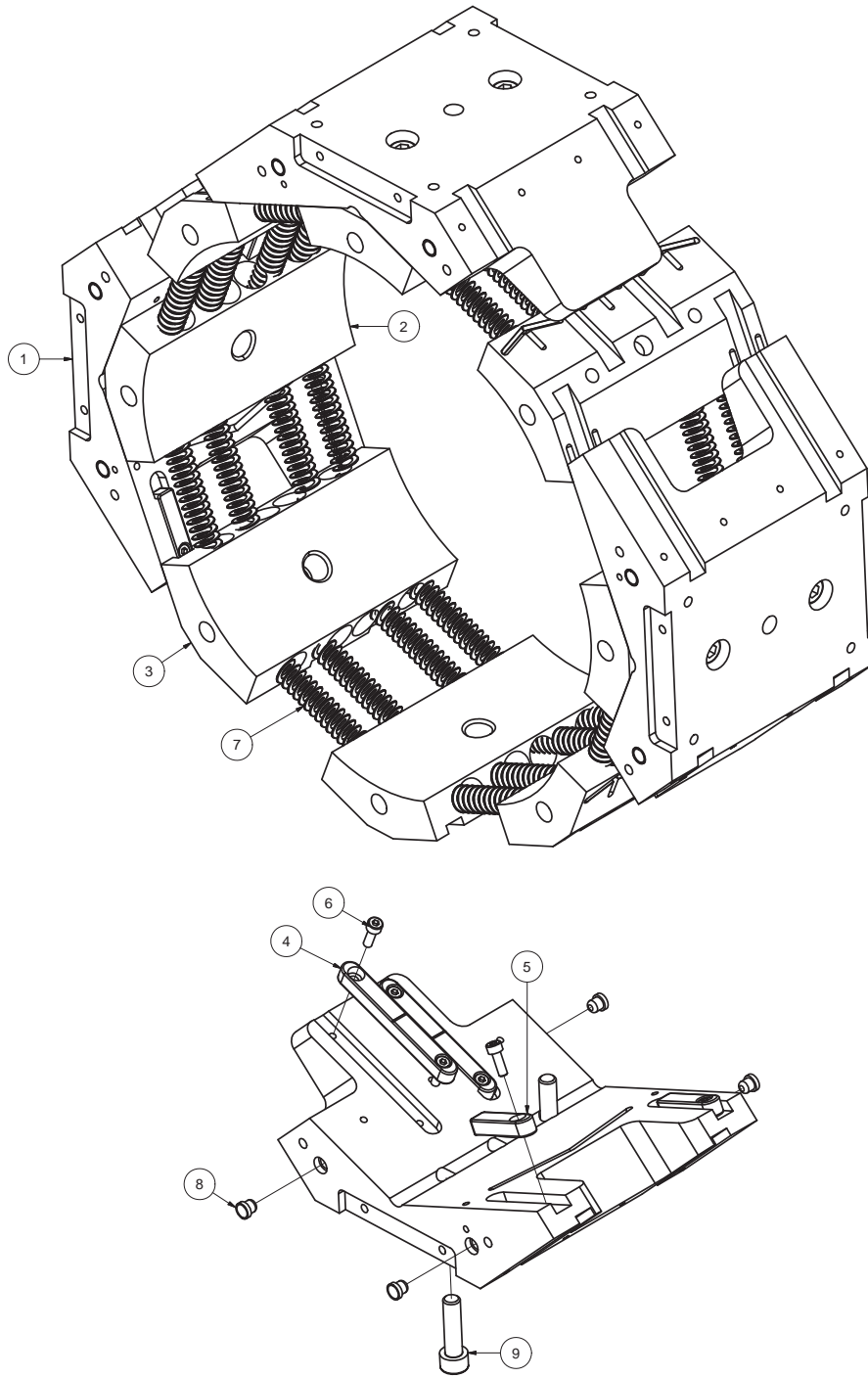

CC650 Master Die Assembly (103954) Current as of 11/2/12

ITEM	PART NUMBER	DESCRIPTION	QTY
1	104128	CC650 Master Die Carrier	4
2	103930	CC650 Master Die Shoes	4
3	103930-R	CC650 Master Die Shoes	4
4	103367	Medium T-Nut	8
5	103464	Short T-Nut	8
6	91290A148	M4 X 12 SHCS	24
7	103955	Master Die Spring	32
8	102793	6mm Flush Style Grease Fitting	16

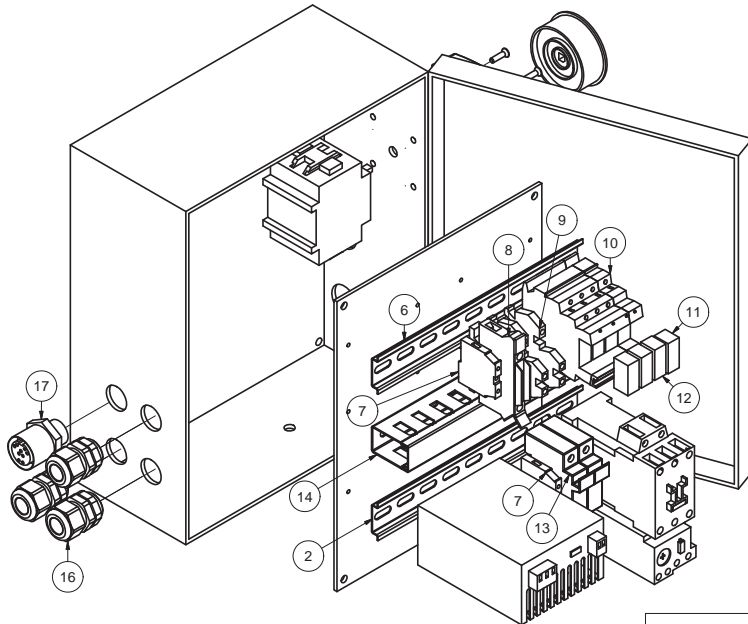

CC600 Electrical Enclosure Assembly (103759)			
ITEM	PART NUMBER	DESCRIPTION	QTY
1	103796	Electrical Enclosure	1
2	103797	Electrical Enclosure Circuit Panel	1
3	102371-120/230	230V Power Supply	1
3	102371-480	480V Power Supply	1
4	103827-2500	230VAC-5HP/7.5HP Overload Relay	3
4	103827-1300	480VAC Overload Relay	1
4	102369-230-25A	230VAC-5HP/7.5HP Motor Contactor	1
5	103151	63 Amp Disconnect Switch	1
5	103050	50 Amp Disconnect Switch	1
6	103788	8.75" Din Rail	2
7	102365	Ground Terminal Block	2
8	102367	Fuse Block	1
9	103775	2 Level Terminal Block	2
10	102368	Relay Block	4
11	102368	White Relay Block (Motor)	1
12	103782	Black Relay Block	3
13	103777	Midget 5 AMP Fuse Holder (230V)	1
13	103882	Midget 5 AMP Fuse Holder (480V)	1
13	103778	Midget 5 AMP Fuse	2
14	103868	8.75" Plastic Wire Duct	1
15	103799	3/4" NPT Cord Grip	2
16	103798	1/2" NPT Romex Cord Grip	3
17	103780	9 Pole Female Receptacle w/Pigtails	1

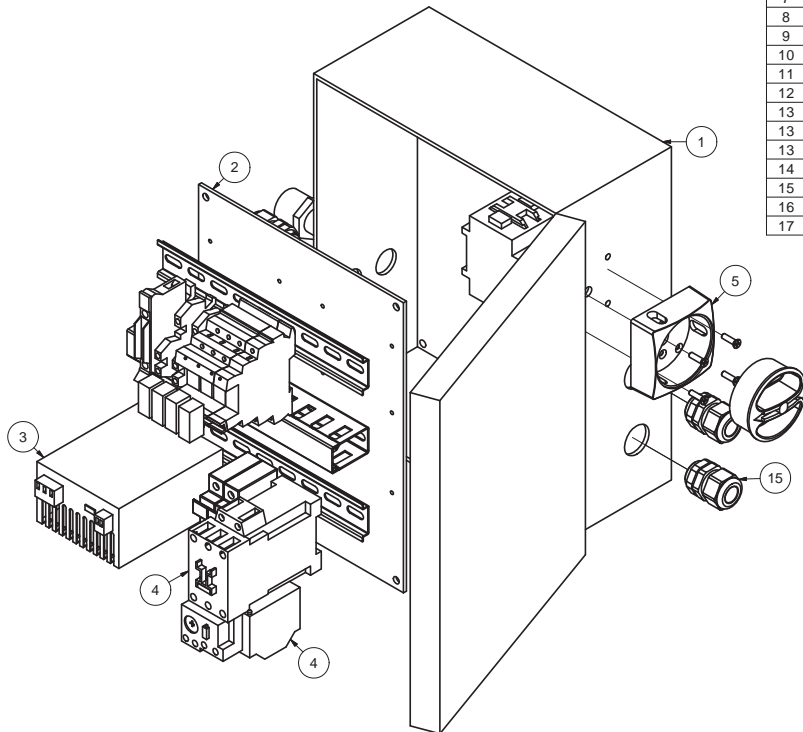

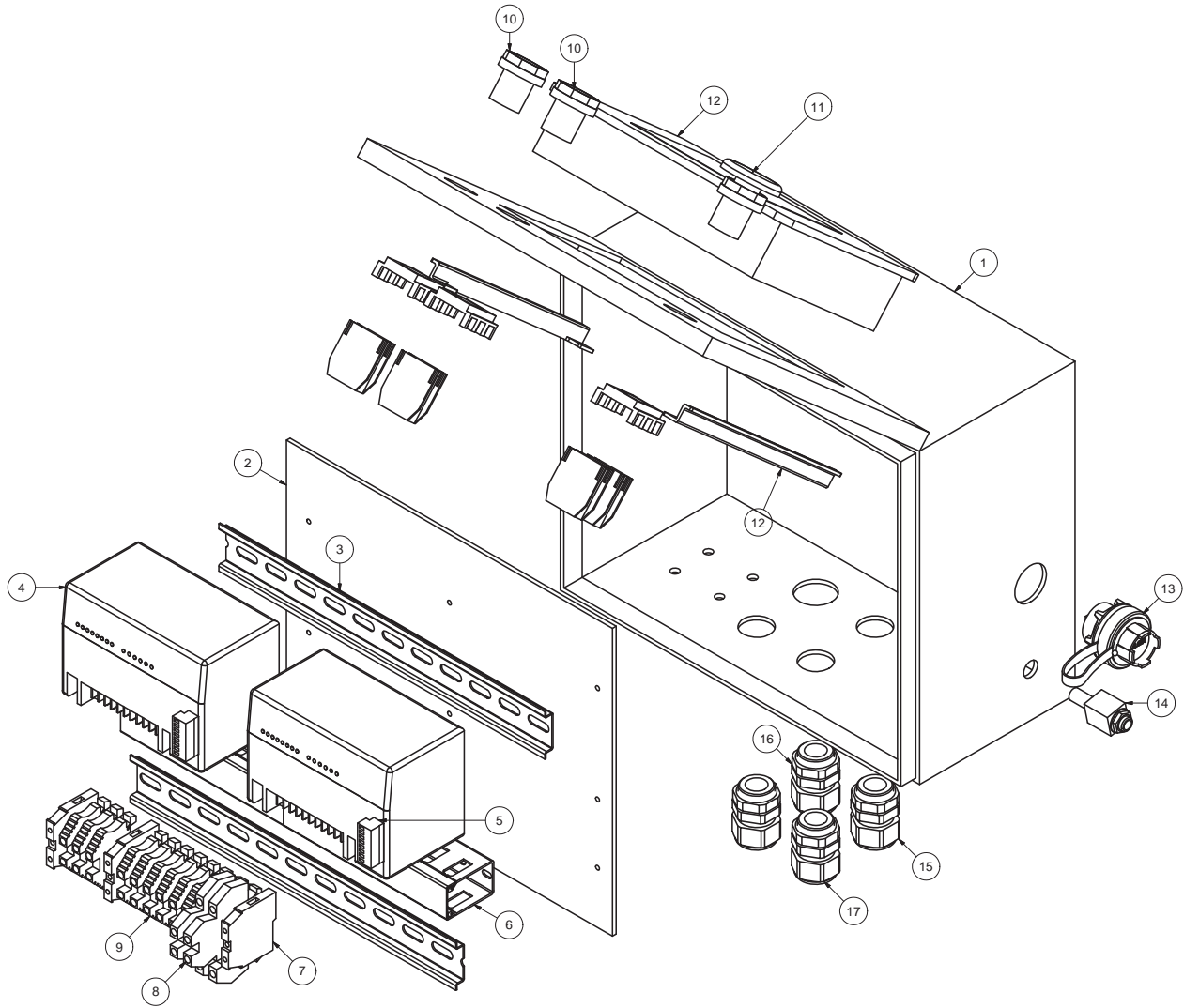

CC600/1000/Nut Crimper Tower Box Assembly (103761)			
ITEM	PART NUMBER	DESCRIPTION	QTY
1	103802	CC600/1000/Nut Crimper Tower Box	1
2	103761	Tower Box Electrical Panel	1
3	103788	11" Din Rail	2
4	102370-PLC	DL05 PLC	2
5	102370-ACT	0-10V Analog In/Out Card	1
6	103868	11" Plastic Wire Duct	1
7	102365	Ground Terminal Block	3
8	103775	2 Level Terminal Block	2
9	103785	Terminal Block	9
10	101545-GREEN	Open/Close Push Button	2
11	101545-RED	Emergency Stop Button	1
12	102600-ACT	6" Touch Screen Text Panel	1
13	103792	USB Connector	1
14	103874	Foot Pedal Receptical	1
15	103828	3/4" NPT Cord Grip	1
16	103800	1/2" NPT Romex Cord Grip	1
17	103801	3/8" NPT Cord Grip	2

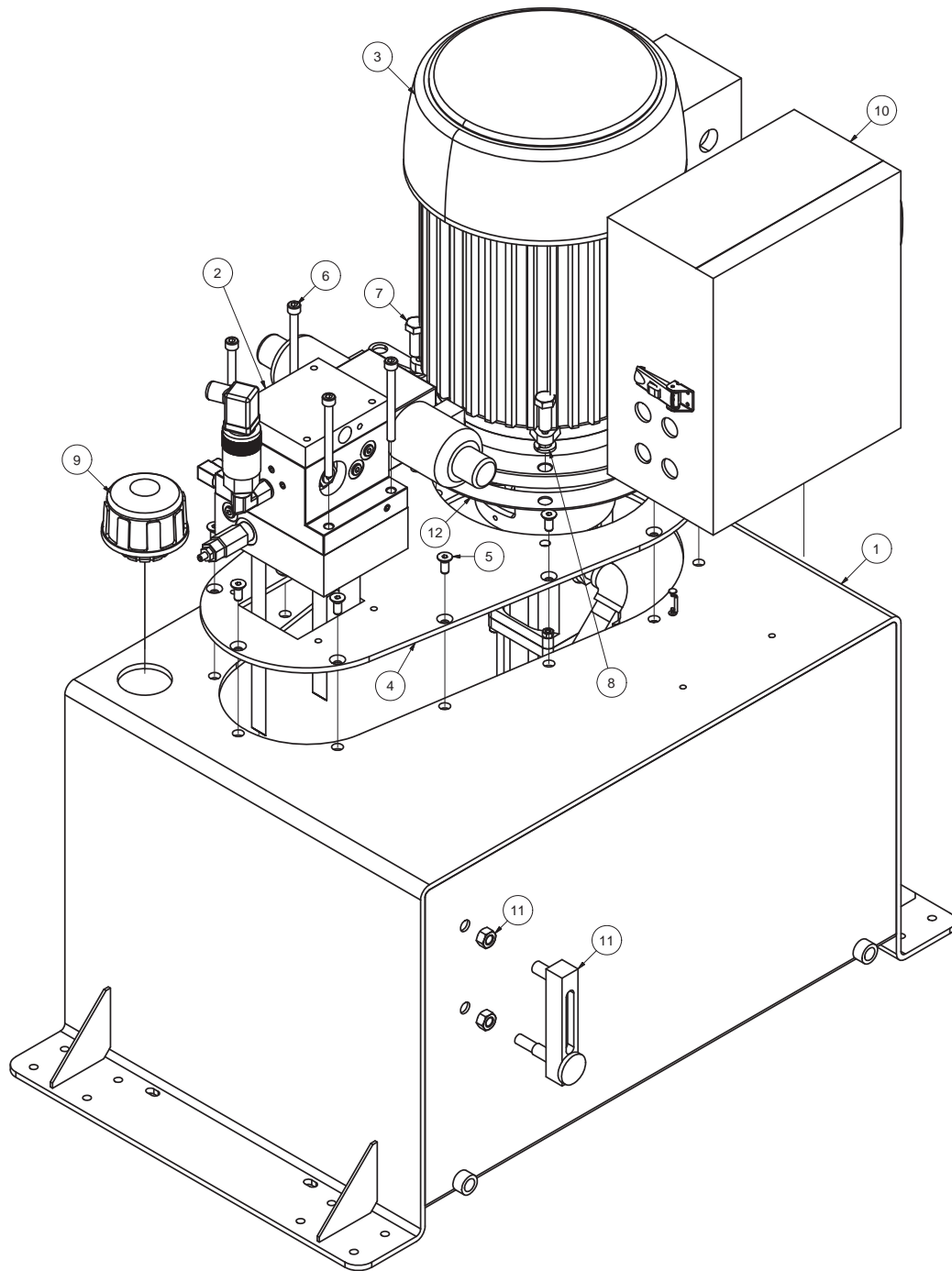

CC600 Power Unit Assembly (103758)			
ITEM	PART NUMBER	DESCRIPTION	QTY
1	103278	24 Gallon Tank	1
2	102523	CC1000/600 Manifold Block Assembly	1
3	103760	CC1000/600 Motor and Pump Assembly	1
4	102618-03	Reservoir Top Plate	1
5	SKF14342	5/16-18 x 3/4 FHCS	12
6	91290A466	M8 x 90 SHCS	4
7	NC51622-Z	1/2-13 x 1 1/4 HHS	4
8	WLK3508-Z	1/2 Lock Washer	4
9	103048	Venter Filler Cap	1
10	103759	Electrical Sub Assembly	1
11	103808	Sight Filler Glass	1
12	101539-01	Flange Gasket	1



## Parker Safety Guide for Selecting and Using Hose, Tubing, Fittings, Connectors, Conductors, Valves and Related Accessories

Parker Publication No. 4400-B.1

**WARNING:** Failure or improper selection or improper use of hose, tubing, fittings, assemblies, valves, connectors, conductors or related accessories (“Products”) can cause death, personal injury and property damage. Possible consequences of failure or improper selection or improper use of these Products include but are not limited to:

- Fittings thrown off at high speed.
- High velocity fluid discharge.
- Explosion or burning of the conveyed fluid.
- Electrocutation from high voltage electric powerlines.
- Contact with suddenly moving or falling objects that are controlled by the conveyed fluid.
- Injections by high-pressure fluid discharge.
- Dangerously whipping Hose.
- Tube or pipe burst.
- Weld joint fracture.
- Contact with conveyed fluids that may be hot, cold, toxic or otherwise injurious.
- Sparking or explosion caused by static electricity buildup or other sources of electricity.
- Sparking or explosion while spraying paint or flammable liquids.
- Injuries resulting from inhalation, ingestion or exposure to fluids.

Before selecting or using any of these Products, it is important that you read and follow the instructions below. No product from any division in Parker Fluid Connectors Group is approved for in-flight aerospace applications. For hoses and fittings used in in-flight aerospace applications, please contact Parker Aerospace Group.

### 1.0 GENERAL INSTRUCTIONS

- 1.1 Scope:** This safety guide provides instructions for selecting and using (including assembling, installing, and maintaining) these Products. For convenience, all rubber and/or thermoplastic products commonly called “hose” or “tubing” are called “Hose” in this safety guide. Metallic tube or pipe are called “tube”. All assemblies made with Hose are called “Hose Assemblies”. All assemblies made with Tube are called “Tube Assemblies”. All products commonly called “fittings”, “couplings” or “adapters” are called “Fittings”. Valves are fluid system components that control the passage of fluid. Related accessories are ancillary devices that enhance or monitor performance including crimping, flaring, flanging, presetting, bending, cutting, deburring, swaging machines, sensors, tags, lockout handles, spring guards and associated tooling. This safety guide is a supplement to and is to be used with the specific Parker publications for the specific Hose, Fittings and Related Accessories that are being considered for use. Parker publications are available at [www.parker.com](http://www.parker.com). SAE J1273 ([www.sae.org](http://www.sae.org)) and ISO 17165-2 ([www.ansi.org](http://www.ansi.org)) also provide recommended practices for hydraulic Hose Assemblies, and should be followed.
- 1.2 Fail-Safe:** Hose, Hose Assemblies, Tube, Tube Assemblies and Fittings can and do fail without warning for many reasons. Design all systems and equipment in a fail-safe mode, so that failure of the Hose, Hose Assembly, Tube, Tube Assembly or Fitting will not endanger persons or property.
- 1.3 Distribution:** Provide a copy of this safety guide to each person responsible for selecting or using Hose, Tube and Fitting products. Do not select or use Parker Hose, Tube or Fittings without thoroughly reading and understanding this safety guide as well as the specific Parker publications for the Products.
- 1.4 User Responsibility:** Due to the wide variety of operating conditions and applications for Hose, Tube and Fittings. Parker does not represent or warrant that any particular Hose, Tube or Fitting is suitable for any specific end use system. This safety guide does not analyze all technical parameters that must be considered in selecting a product. The user, through its own analysis and testing, is solely responsible for:
- Making the final selection of the Products.
  - Assuring that the user’s requirements are met and that the application presents no health or safety hazards.
  - Following the safety guide for Related Accessories and being trained to operate Related Accessories.
  - Providing all appropriate health and safety warnings on the equipment on which the Products are used.
  - Assuring compliance with all applicable government and industry standards.
- 1.5 Additional Questions:** Call the appropriate Parker technical service department if you have any questions or require any additional information. See the Parker publication for the Products being considered or used, or call 1-800-CPARKER, or go to [www.parker.com](http://www.parker.com), for telephone numbers of the appropriate technical service department.

### 2.0 HOSE, TUBE AND FITTINGS SELECTION INSTRUCTIONS

- 2.1 Electrical Conductivity:** Certain applications require that the Hose be nonconductive to prevent electrical current flow. Other applications require the Hose and the Fittings and the Hose/Fitting interface to be sufficiently conductive to drain off static electricity. Extreme care must be exercised when selecting Hose, Tube and Fittings for these or any other applications in which electrical conductivity or nonconductivity is a factor.
- The electrical conductivity or nonconductivity of Hose, Tube and Fittings is dependent upon many factors and may be susceptible to change. These factors include but are not limited to the various materials used to make the Hose and the Fittings, Fitting finish (some Fitting finishes are electrically conductive while others are nonconductive), manufacturing methods (including moisture control), how the Fittings contact the Hose, age and amount of deterioration or damage or other changes, moisture content of the Hose at any particular time, and other factors.
- The following are considerations for electrically nonconductive and conductive Hose. For other applications consult the individual catalog pages and the appropriate industry or regulatory standards for proper selection.
- 2.1.1 Electrically Nonconductive Hose:** Certain applications require that the Hose be nonconductive to prevent electrical current flow or to maintain electrical isolation. For applications that require Hose to be electrically nonconductive, including but not limited to applications near high voltage electric lines, only special nonconductive Hose can be used. The manufacturer of the equipment in which the nonconductive Hose is to be used must be consulted to be certain that the Hose, Tube and Fittings that are selected are proper for the application. Do not use any Parker Hose or Fittings for any such application requiring nonconductive Hose, including but not limited to applications near high voltage electric lines or dense magnetic fields, unless (i) the application is expressly approved in the Parker technical publication for the product, (ii) the Hose is marked “nonconductive”, and (iii) the manufacturer of the equipment on which the Hose is to be used specifically approves the particular Parker Hose, Tube and Fittings for such use.
- 2.1.2 Electrically Conductive Hose:** Parker manufactures special Hose for certain applications that require electrically conductive Hose. Parker manufactures special Hose for conveying paint in airless paint spraying applications. This Hose is labeled “Electrically Conductive Airless Paint Spray Hose” on its lay-line and packaging. This Hose must be properly connected to the appropriate Parker Fittings and properly grounded in order to dissipate dangerous static charge buildup, which occurs in all airless paint spraying applications. Do not use any other Hose for airless paint spraying, even if electrically conductive. Use of any other Hose or failure to properly connect the Hose can cause a fire or an explosion resulting in death, personal injury, and property damage. All hoses that convey fuels must be grounded.
- Parker manufactures a special Hose for certain compressed natural gas (“CNG”) applications where static electricity buildup may occur. Parker CNG Hose assemblies comply with the requirements of ANSI/IAS NGV 4.2; CSA 12.52, “Hoses for Natural Gas Vehicles and Dispensing Systems” ([www.ansi.org](http://www.ansi.org)). This Hose is labeled “Electrically Conductive for CNG Use”

## Parker Safety Guide, Parker Publication No. 4400-B.1 (continued)

on its layline and packaging. This Hose must be properly connected to the appropriate Parker Fittings and properly grounded in order to dissipate dangerous static charge buildup, which occurs in, for example, high velocity CNG dispensing or transfer. Do not use any other Hose for CNG applications where static charge buildup may occur, even if electrically conductive. Use of other Hoses in CNG applications or failure to properly connect or ground this Hose can cause a fire or an explosion resulting in death, personal injury, and property damage. Care must also be taken to protect against CNG permeation through the Hose wall. See section 2.6, Permeation, for more information. Parker CNG Hose is intended for dispenser and vehicle use within the specified temperature range. Parker CNG Hose should not be used in confined spaces or unventilated areas or areas exceeding the specified temperature range. Final assemblies must be tested for leaks. CNG Hose Assemblies should be tested on a monthly basis for conductivity per ANSI/IAS NGV 4.2; CSA 12.52.

Parker manufactures special Hose for aerospace in-flight applications. Aerospace in-flight applications employing Hose to transmit fuel, lubricating fluids and hydraulic fluids require a special Hose with a conductive inner tube. This Hose for in-flight applications is available only from Parker's Stratoflex Products Division. Do not use any other Parker Hose for in-flight applications, even if electrically conductive. Use of other Hoses for in-flight applications or failure to properly connect or ground this Hose can cause a fire or an explosion resulting in death, personal injury and property damage. These Hose assemblies for in-flight applications must meet all applicable aerospace industry, aircraft engine and aircraft requirements.

- 2.2 Pressure:** Hose, Tube and Fitting selection must be made so that the published maximum working pressure of the Hose, Tube and Fittings are equal to or greater than the maximum system pressure. The maximum working pressure of a Hose, or Tube Assembly is the lower of the respective published maximum working pressures of the Hose, Tube and the Fittings used. Surge pressures or peak transient pressures in the system must be below the published maximum working pressure for the Hose, Tube and Fitting. Surge pressures and peak pressures can usually only be determined by sensitive electrical instrumentation that measures and indicates pressures at millisecond intervals. Mechanical pressure gauges indicate only average pressures and cannot be used to determine surge pressures or peak transient pressures. Published burst pressure ratings for Hose is for manufacturing test purposes only and is no indication that the Product can be used in applications at the burst pressure or otherwise above the published maximum recommended working pressure.
- 2.3 Suction:** Hoses used for suction applications must be selected to insure that the Hose will withstand the vacuum and pressure of the system. Improperly selected Hose may collapse in suction application.
- 2.4 Temperature:** Be certain that fluid and ambient temperatures, both steady and transient, do not exceed the limitations of the Hose, Tube, Fitting and Seals. Temperatures below and above the recommended limit can degrade Hose, Tube, Fittings and Seals to a point where a failure may occur and release fluid. Tube and Fittings performances are normally degraded at elevated temperature. Material compatibility can also change at temperatures outside of the rated range. Properly insulate and protect the Hose Assembly when routing near hot objects (e.g. manifolds). Do not use any Hose in any application where failure of the Hose could result in the conveyed fluids (or vapors or mist from the conveyed fluids) contacting any open flame, molten metal, or other potential fire ignition source that could cause burning or explosion of the conveyed fluids or vapors.
- 2.5 Fluid Compatibility:** Hose, and Tube Assembly selection must assure compatibility of the Hose tube, cover, reinforcement, Tube, Plating and Seals with the fluid media used. See the fluid compatibility chart in the Parker publication for the product being considered or used. This information is offered only as a guide. Actual service life can only be determined by the end user by testing under all extreme conditions and other analysis. Hose, and Tube that is chemically compatible with a particular fluid must be assembled using Fittings and adapters containing likewise compatible seals. Flange or flare processes can change Tube material properties that may not be compatible with certain requirements such as NACE
- 2.6 Permeation:** Permeation (that is, seepage through the Hose or Seal) will occur from inside the Hose or Fitting to outside when Hose or Fitting is used with gases, liquid and gas fuels, and refrigerants (including but not limited to such materials as helium, diesel fuel, gasoline, natural gas, or LPG). This permeation may result in high concentrations of vapors which are potentially flammable, explosive, or toxic, and in loss of fluid. Dangerous explosions, fires, and other hazards can result when using the wrong Hose for such applications. The system designer must take into account the fact that this permeation will take place and must not use Hose or Fitting if this permeation could be hazardous. The system designer must take into account all legal, government, insurance, or any other special regulations which govern the use of fuels and refrigerants. Never use a Hose or Fitting even though the fluid compatibility is acceptable without considering the potential hazardous effects that can result from permeation through the Hose or Tube Assembly.
- Permeation of moisture from outside the Hose or Fitting to inside the Hose or Fitting will also occur in Hose or Tube assemblies, regardless of internal pressure. If this moisture permeation would have detrimental effects (particularly, but not limited to refrigeration and air conditioning systems), incorporation of sufficient drying capacity in the system or other appropriate system safeguards should be selected and used. The sudden pressure release of highly pressurized gas could also result in Explosive Decompression failure of permeated Seals and Hoses.
- 2.7 Size:** Transmission of power by means of pressurized fluid varies with pressure and rate of flow. The size of the components must be adequate to keep pressure losses to a minimum and avoid damage due to heat generation or excessive fluid velocity.
- 2.8 Routing:** Attention must be given to optimum routing to minimize inherent problems (kinking or flow restriction due to Hose collapse, twisting of the Hose, proximity to hot objects or heat sources). For additional routing recommendations see SAE J1273 and ISO 17165-2. Hose Assemblies have a finite life and should be installed in a manner that allows for ease of inspection and future replacement. Hose because of its relative short life, should not be used in residential and commercial buildings inside of inaccessible walls or floors, unless specifically allowed in the product literature. Always review all product literature for proper installation and routing instructions.
- 2.9 Environment:** Care must be taken to insure that the Hose, Tube and Fittings are either compatible with or protected from the environment (that is, surrounding conditions) to which they are exposed. Environmental conditions including but not limited to ultraviolet radiation, sunlight, heat, ozone, moisture, water, salt water, chemicals and air pollutants can cause degradation and premature failure.
- 2.10 Mechanical Loads:** External forces can significantly reduce Hose, Tube and Fitting life or cause failure. Mechanical loads which must be considered include excessive flexing, twist, kinking, tensile or side loads, bend radius, and vibration. Use of swivel type Fittings or adapters may be required to insure no twist is put into the Hose. Use of proper Hose or Tube clamps may also be required to reduce external mechanical loads. Unusual applications may require special testing prior to Hose selection.
- 2.11 Physical Damage:** Care must be taken to protect Hose from wear, snagging, kinking, bending smaller than minimum bend radius and cutting, any of which can cause premature Hose failure. Any Hose that has been kinked or bent to a radius smaller than the minimum bend radius, and any Hose that has been cut or is cracked or is otherwise damaged should be removed and discarded. Fittings with damages such as scratches on sealing surfaces and deformation should be replaced.
- 2.12 Proper End Fitting:** See instructions 3.2 through 3.5. These recommendations may be substantiated by testing to industry standards such as SAE J517 for hydraulic applications, or MIL-A-5070, AS1339, or AS3517 for Hoses from Parker's Stratoflex Products Division for aerospace applications.
- 2.13 Length:** When determining the proper Hose or Tube length of an assembly, be aware of Hose length change due to pressure, Tube length change due to thermal expansion or contraction, and Hose or Tube and machine tolerances and movement must be considered. When routing short hose assemblies, it is recommended that the minimum free hose length is always used. Consult the hose manufacturer for their minimum free hose length recommendations. Hose assemblies should be installed in such a way that any motion or flexing occurs within the same plane.
- 2.14 Specifications and Standards:** When selecting Hose, Tube and Fittings, government, industry, and Parker specifications and recommendations must be reviewed and followed as applicable.
- 2.15 Hose Cleanliness:** Hose and Tube components may vary in cleanliness levels. Care must be taken to insure that the Hose and Tube Assembly selected has an adequate level of cleanliness for the application.
- 2.16 Fire Resistant Fluids:** Some fire resistant fluids that are to be conveyed by Hose or Tube require use of the same type of Hose or Tube as used with petroleum base fluids. Some such fluids require a special Hose, Tube, Fitting and Seal, while a few fluids will not work with any Hose at all. See instructions 2.5 and 1.5. The wrong Hose, Tube, Fitting or Seal may fail after a very short service. In addition, all liquids but pure water may burn fiercely under certain conditions, and even pure water leakage may be hazardous.

## Parker Safety Guide, Parker Publication No. 4400-B.1 (continued)

- 2.17 Radiant Heat:** Hose and Seals can be heated to destruction without contact by such nearby items as hot manifolds or molten metal. The same heat source may then initiate a fire. This can occur despite the presence of cool air around the Hose or Seal. Performance of Tube and Fitting subjected to the heat could be degraded.
- 2.18 Welding or Brazing:** When using a torch or arc welder in close proximity to hydraulic lines, the hydraulic lines should be removed or shielded with appropriate fire resistant materials. Flame or weld spatter could burn through the Hose or Seal and possibly ignite escaping fluid resulting in a catastrophic failure. Heating of plated parts, including Hose Fittings and adapters, above 450°F (232°C) such as during welding, brazing or soldering may emit deadly gases. Any elastomer seal on fittings shall be removed prior to welding or brazing, any metallic surfaces shall be protected after brazing or welding when necessary. Welding and brazing filler material shall be compatible with the Tube and Fitting that are joined.
- 2.19 Atomic Radiation:** Atomic radiation affects all materials used in Hose and Tube assemblies. Since the long-term effects may be unknown, do not expose Hose or Tube assemblies to atomic radiation. Nuclear applications may require special Tube and Fittings.
- 2.20 Aerospace Applications:** The only Hose, Tube and Fittings that may be used for in-flight aerospace applications are those available from Parker's Stratoflex Products Division. Do not use any other Hose or Fittings for in-flight applications. Do not use any Hose or Fittings from Parker's Stratoflex Products Division with any other Hose or Fittings, unless expressly approved in writing by the engineering manager or chief engineer of Stratoflex Products Division and verified by the user's own testing and inspection to aerospace industry standards.
- 2.21 Unlocking Couplings:** Ball locking couplings or other Fittings with quick disconnect ability can unintentionally disconnect if they are dragged over obstructions, or if the sleeve or other disconnect member, is bumped or moved enough to cause disconnect. Threaded Fittings should be considered where there is a potential for accidental uncoupling.
- 3.0 HOSE AND FITTINGS ASSEMBLY AND INSTALLATION INSTRUCTIONS**
- 3.1 Component Inspection:** Prior to assembly, a careful examination of the Hose and Fittings must be performed. All components must be checked for correct style, size, catalog number, and length. The Hose must be examined for cleanliness, obstructions, blisters, cover looseness, kinks, cracks, cuts or any other visible defects. Inspect the Fitting and sealing surfaces for burrs, nicks, corrosion or other imperfections. Do NOT use any component that displays any signs of nonconformance.
- 3.2 Hose and Fitting Assembly:** Do not assemble a Parker Fitting on a Parker Hose that is not specifically listed by Parker for that Fitting, unless authorized in writing by the engineering manager or chief engineer of the appropriate Parker division. Do not assemble a Parker Fitting on another manufacturer's Hose or a Parker Hose on another manufacturer's Fitting unless (i) the engineering manager or chief engineer of the appropriate Parker division approves the Assembly in writing or that combination is expressly approved in the appropriate Parker literature for the specific Parker product, and (ii) the user verifies the Assembly and the application through analysis and testing. For Parker Hose that does not specify a Parker Fitting, the user is solely responsible for the selection of the proper Fitting and Hose Assembly procedures. See instruction 1.4.
- To prevent the possibility of problems such as leakage at the Fitting or system contamination, it is important to completely remove all debris from the cutting operation before installation of the Fittings. The Parker published instructions must be followed for assembling the Fittings on the Hose. These instructions are provided in the Parker Fitting catalog for the specific Parker Fitting being used, or by calling 1-800-CPARKER, or at [www.parker.com](http://www.parker.com).
- 3.3 Related Accessories:** Do not crimp or swage any Parker Hose or Fitting with anything but the listed swage or crimp machine and dies in accordance with Parker published instructions. Do not crimp or swage another manufacturer's Fitting with a Parker crimp or swage die unless authorized in writing by the engineering manager or chief engineer of the appropriate Parker division.
- 3.4 Parts:** Do not use any Parker Fitting part (including but not limited to socket, shell, nipple, or insert) except with the correct Parker mating parts, in accordance with Parker published instructions, unless authorized in writing by the engineering manager or chief engineer of the appropriate Parker division.
- 3.5 Field Attachable/Permanent:** Do not reuse any field attachable Hose Fitting that has blown or pulled off a Hose. Do not reuse a Parker permanent Hose Fitting (crimped or swaged) or any part thereof. Complete Hose Assemblies may only be reused after proper inspection under section 4.0. Do not assemble Fittings to any previously used hydraulic Hose that was in service, for use in a fluid power application.
- 3.6 Pre-Installation Inspection:** Prior to installation, a careful examination of the Hose Assembly must be performed. Inspect the Hose Assembly for any damage or defects. DO NOT use any Hose Assembly that displays any signs of nonconformance.
- 3.7 Minimum Bend Radius:** Installation of a Hose at less than the minimum listed bend radius may significantly reduce the Hose life. Particular attention must be given to preclude sharp bending at the Hose to Fitting juncture. Any bending during installation at less than the minimum bend radius must be avoided. If any Hose is kinked during installation, the Hose must be discarded.
- 3.8 Twist Angle and Orientation:** Hose Assembly installation must be such that relative motion of machine components does not produce twisting.
- 3.9 Securement:** In many applications, it may be necessary to restrain, protect, or guide the Hose to protect it from damage by unnecessary flexing, pressure surges, and contact with other mechanical components. Care must be taken to insure such restraints do not introduce additional stress or wear points.
- 3.10 Proper Connection of Ports:** Proper physical installation of the Hose Assembly requires a correctly installed port connection insuring that no twist or torque is transferred to the Hose when the Fittings are being tightened or otherwise during use.
- 3.11 External Damage:** Proper installation is not complete without insuring that tensile loads, side loads, kinking, flattening, potential abrasion, thread damage or damage to sealing surfaces are corrected or eliminated. See instruction 2.10.
- 3.12 System Checkout:** All air entrapment must be eliminated and the system pressurized to the maximum system pressure (at or below the Hose maximum working pressure) and checked for proper function and freedom from leaks. Personnel must stay out of potential hazardous areas while testing and using.
- 3.13 Routing:** The Hose Assembly should be routed in such a manner so if a failure does occur, the escaping media will not cause personal injury or property damage. In addition, if fluid media comes in contact with hot surfaces, open flame or sparks, a fire or explosion may occur. See section 2.4.
- 3.14 Ground Fault Equipment Protection Devices (GFEEDs): WARNING! Fire and Shock Hazard.** To minimize the danger of fire if the heating cable of a Multitube bundle is damaged or improperly installed, use a Ground Fault Equipment Protection Device. Electrical fault currents may be insufficient to trip a conventional circuit breaker.
- For ground fault protection, the IEEE 515:** ([www.ansi.org](http://www.ansi.org)) standard for heating cables recommends the use of GFEEDs with a nominal 30 milliamperere trip level for "piping systems in classified areas, those areas requiring a high degree of maintenance, or which may be exposed to physical abuse or corrosive atmospheres".
- 4.0 TUBE AND FITTINGS ASSEMBLY AND INSTALLATION INSTRUCTIONS**
- 4.1 Component Inspection:** Prior to assembly, a careful examination of the Tube and Fittings must be performed. All components must be checked for correct style, size, material, seal, and length. Inspect the Fitting and sealing surfaces for burrs, nicks, corrosion, missing seal or other imperfections. Do NOT use any component that displays any signs of nonconformance.
- 4.2 Tube and Fitting Assembly:** Do not assemble a Parker Fitting with a Tube that is not specifically listed by Parker for that Fitting, unless authorized in writing by the engineering manager or chief engineer of the appropriate Parker division. The Tube must meet the requirements specified to the Fitting.
- The Parker published instructions must be followed for assembling the Fittings to a Tube. These instructions are provided in the Parker Fitting catalog for the specific Parker Fitting being used, or by calling 1-800-CPARKER, or at [www.parker.com](http://www.parker.com).
- 4.3 Related Accessories:** Do not preset or flange Parker Fitting components using another manufacturer's equipment or procedures unless authorized in writing by the engineering manager or chief engineer of the appropriate Parker division. Tube, Fitting component and tooling must be checked for correct style, size and material. Operation and maintenance of Related Accessories must be in accordance with the operation manual for the designated Accessory.
- 4.4 Securement:** In many applications, it may be necessary to restrain, protect, or guide the Tube to protect it from damage by unnecessary flexing, pressure surges, vibration, and contact with other mechanical components. Care must be taken to insure such restraints do not introduce additional stress or wear points.

**Parker Safety Guide, Parker Publication No. 4400-B.1 (continued)**

- 4.5 **Proper Connection of Ports:** Proper physical installation of the Tube Assembly requires a correctly installed port connection insuring that no torque is transferred to the Tube when the Fittings are being tightened or otherwise during use.
- 4.6 **External Damage:** Proper installation is not complete without insuring that tensile loads, side loads, flattening, potential abrasion, thread damage or damage to sealing surfaces are corrected or eliminated. See instruction 2.10.
- 4.7 **System Checkout:** All air entrapment must be eliminated and the system pressurized to the maximum system pressure (at or below the Tube Assembly maximum working pressure) and checked for proper function and freedom from leaks. Personnel must stay out of potential hazardous areas while testing and using.
- 4.8 **Routing:** The Tube Assembly should be routed in such a manner so if a failure does occur, the escaping media will not cause personal injury or property damage. In addition, if fluid media comes in contact with hot surfaces, open flame or sparks, a fire or explosion may occur. See section 2.4.
- 5.0 **HOSE AND FITTING MAINTENANCE AND REPLACEMENT INSTRUCTIONS**
- 5.1 Even with proper selection and installation, Hose life may be significantly reduced without a continuing maintenance program. The severity of the application, risk potential from a possible Hose failure, and experience with any Hose failures in the application or in similar applications should determine the frequency of the inspection and the replacement for the Products so that Products are replaced before any failure occurs. Certain products require maintenance and inspection per industry requirements. Failure to adhere to these requirements may lead to premature failure. A maintenance program must be established and followed by the user and, at minimum, must include instructions 5.2 through 5.7
- 5.2 **Visual Inspection Hose/Fitting:** Any of the following conditions require immediate shut down and replacement of the Hose Assembly:
  - Fitting slippage on Hose;
  - Damaged, cracked, cut or abraded cover (any reinforcement exposed);
  - Hard, stiff, heat cracked, or charred Hose;
  - Cracked, damaged, or badly corroded Fittings;
  - Leaks at Fitting or in Hose;
  - Kinked, crushed, flattened or twisted Hose; and
  - Blistered, soft, degraded, or loose cover.
- 5.3 **Visual Inspection All Other:** The following items must be tightened, repaired, corrected or replaced as required:
  - Leaking port conditions;
  - Excess dirt buildup/
  - Worn clamps, guards or shields; and
  - System fluid level, fluid type, and any air entrapment.
- 5.4 **Functional Test:** Operate the system at maximum operating pressure and check for possible malfunctions and leaks. Personnel must avoid potential hazardous areas while testing and using the system. See section 2.2.
- 5.5 **Replacement Intervals:** Hose assemblies and elastomeric seals used on Hose Fittings and adapters will eventually age, harden, wear and deteriorate under thermal cycling and compression set. Hose Assemblies and elastomeric seals should be inspected and replaced at specific replacement intervals, based on previous service life, government or industry recommendations, or when failures could result in unacceptable downtime, damage, or injury risk. See section 1.2. Hose and Fittings may be subjected to internal mechanical and/or chemical wear from the conveying fluid and may fail without warning. The user must determine the product life under such circumstances by testing. Also see section 2.5.
- 5.6 **Hose Inspection and Failure:** Hydraulic power is accomplished by utilizing high pressure fluids to transfer energy and do work. Hoses, Fittings and Hose Assemblies all contribute to this by transmitting fluids at high pressures. Fluids under pressure can be dangerous and potentially lethal and, therefore, extreme caution must be exercised when working with fluids under pressure and handling the Hoses transporting the fluids. From time to time, Hose

Assemblies will fail if they are not replaced at proper time intervals. Usually these failures are the result of some form of misapplication, abuse, wear or failure to perform proper maintenance. When Hoses fail, generally the high pressure fluids inside escape in a stream which may or may not be visible to the user. Under no circumstances should the user attempt to locate the leak by "feeling" with their hands or any other part of their body. High pressure fluids can and will penetrate the skin and cause severe tissue damage and possibly loss of limb. Even seemingly minor hydraulic fluid injection injuries must be treated immediately by a physician with knowledge of the tissue damaging properties of hydraulic fluid.

If a Hose failure occurs, immediately shut down the equipment and leave the area until pressure has been completely released from the Hose Assembly. Simply shutting down the hydraulic pump may or may not eliminate the pressure in the Hose Assembly. Many times check valves, etc., are employed in a system and can cause pressure to remain in a Hose Assembly even when pumps or equipment are not operating. Tiny holes in the Hose, commonly known as pinholes, can eject small, dangerously powerful but hard to see streams of hydraulic fluid. It may take several minutes or even hours for the pressure to be relieved so that the Hose Assembly may be examined safely.

Once the pressure has been reduced to zero, the Hose Assembly may be taken off the equipment and examined. It must always be replaced if a failure has occurred. Never attempt to patch or repair a Hose Assembly that has failed. Consult the nearest Parker distributor or the appropriate Parker division for Hose Assembly replacement information.

Never touch or examine a failed Hose Assembly unless it is obvious that the Hose no longer contains fluid under pressure. The high pressure fluid is extremely dangerous and can cause serious and potentially fatal injury.

- 5.7 **Elastomeric seals:** Elastomeric seals will eventually age, harden, wear and deteriorate under thermal cycling and compression set. Elastomeric seals should be inspected and replaced.
- 5.8 **Refrigerant gases:** Special care should be taken when working with refrigeration systems. Sudden escape of refrigerant gases can cause blindness if the escaping gases contact the eye and can cause freezing or other severe injuries if it contacts any other portion of the body.
- 5.9 **Compressed natural gas (CNG):** Parker CNG Hose Assemblies should be tested after installation and before use, and at least on a monthly basis per instructions provided on the Hose Assembly tag. The recommended procedure is to pressurize the Hose and check for leaks and to visually inspect the Hose for damage and to perform an electrical resistance test.
 

**Caution:** Matches, candles, open flame or other sources of ignition shall not be used for Hose inspection. Leak check solutions should be rinsed off after use.
- 6.0 **HOSE STORAGE**
- 6.1 **Age Control:** Hose and Hose Assemblies must be stored in a manner that facilitates age control and first-in and first-out usage based on manufacturing date of the Hose and Hose Assemblies. Unless otherwise specified by the manufacturer or defined by local laws and regulations:
  - 6.1.1 The shelf life of rubber hose in bulk form or hose made from two or more materials is 28 quarters (7 years) from the date of manufacture, with an extension of 12 quarters (3 years), if stored in accordance with ISO 2230;
  - 6.1.2 The shelf life of thermoplastic and polytetrafluoroethylene hose is considered to be unlimited;
  - 6.1.3 Hose assemblies that pass visual inspection and proof test shall not be stored for longer than 2 years.
  - 6.1.4 **Storage:** Stored Hose and Hose Assemblies must not be subjected to damage that could reduce their expected service life and must be placed in a cool, dark and dry area with the ends capped. Stored Hose and Hose Assemblies must not be exposed to temperature extremes, ozone, oils, corrosive liquids or fumes, solvents, high humidity, rodents, insects, ultraviolet light, electromagnetic fields or radioactive materials.

<b>Issue Date</b> 24-SEP-2015	<b>ECO Number:</b> XXXXXX	<b>Revision Letter:</b> A	<b>Revision Date:</b> 30-OCT-2015	<b>Specification</b> FC-Safety Guide
----------------------------------	------------------------------	------------------------------	--------------------------------------	---

THIS DOCUMENT CONTAINS INFORMATION THAT IS CONFIDENTIAL AND PROPRIETARY TO PARKER HANNIFIN. THIS DOCUMENT IS FURNISHED ON THE UNDERSTANDING THAT THE DOCUMENT AND THE INFORMATION IT CONTAINS WILL NOT BE COPIED OR DISCLOSED TO OTHERS EXCEPT WITH THE WRITTEN CONSENT OF PARKER, WILL NOT BE USED FOR ANY PURPOSE OTHER THAN CONDUCTING BUSINESS WITH PARKER, AND WILL BE RETURNED AND ALL FURTHER USE DISCONTINUED UPON REQUEST BY PARKER. COPYRIGHT PARKER. YEAR OF COPYRIGHT IS FIRST YEAR INDICATED ON THIS DOCUMENT. ALL RIGHTS RESERVED



Parker Hannifin Corporation  
**Hose Products Division**

30240 Lakeland Blvd  
Wickliffe, OH 44092

Customer Service:

Toll Free 866 810 HOSE (4673)

email [indhose@parker.com](mailto:indhose@parker.com)

[www.parker.com/hpd](http://www.parker.com/hpd)