

General Description

Cartridge Style Shuttle Valve.
 For additional information see Technical Tips on pages SH1-SH2.

Features

- Hardened precision ground parts for durability
- 5000 PSI rated
- All external parts zinc plated

Performance Curve

Pressure Drop vs. Flow (Through cartridge only)

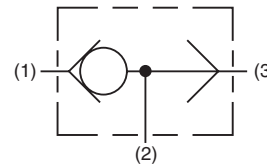
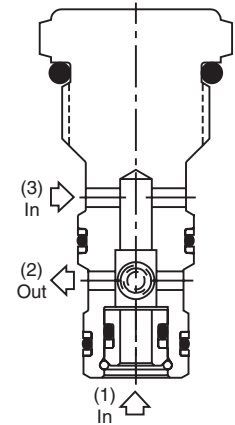
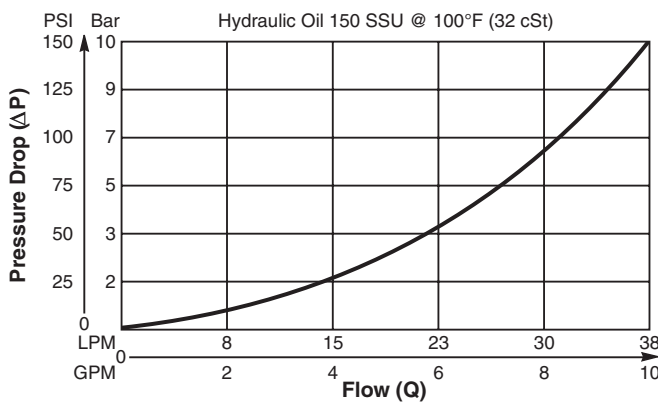

Dimensions Millimeters (Inches)

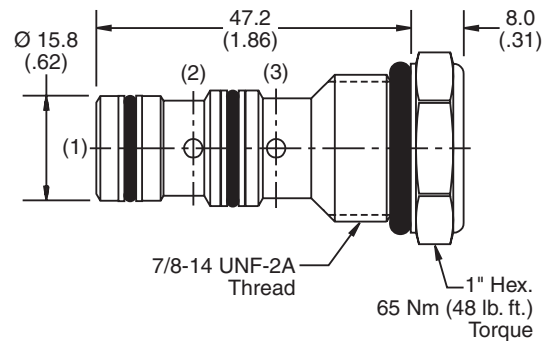

Specifications

Rated Flow	38 LPM (10 GPM)
Maximum Inlet Pressure	350 Bar (5000 PSI)
Leakage at 150 SSU (32cSt)	10 drops/min. (0.67 cc/min.) at 350 Bar (5000 PSI)
Cartridge Material	All parts steel. All operating parts, hardened steel.
Operating Temp. Range/Seals	-34°C to +121°C (Nitrile) (-30°F to +250°F) -26°C to +204°C (Fluorocarbon) (-15°F to +400°F)
Fluid Compatibility/Viscosity	Mineral-based or synthetic with lubricating properties at viscosities of 45 to 2000 SSU (6 to 420 cSt)
Filtration	ISO-4406 18/16/13, SAE Class 4
Approx. Weight	0.14 kg (0.3 lbs.)
Cavity	C10-3 (See BC Section for more details)
Form Tool	Rougher NFT10-3R Finisher NFT10-3F

Ordering Information

CSH101B

10 Size Shuttle Valve Seals

Highlighted represents preferred options that offer the shortest lead times. Other options may be available, but at extended lead times.

Code	Seals / Kit No.
Omit	Nitrile / (SK10-3)
v	Fluorocarbon / (SK10-3V)

Order Bodies Separately
 See section BC

B10 - **3** -

10 size 3-Way Cavity Port Size

Code	Porting / Body Material
8T	SAE-8 / Steel (5000 PSI)
A8T	SAE-8 / Aluminium (3000 PSI)