

- CV**
Check Valves
- SH**
Shuttle Valves
- LM**
Load/Motor Controls
- FC**
Flow Controls
- PC**
Pressure Controls
- LE**
Logic Elements
- DC**
Directional Controls
- MV**
Manual Valves
- SV**
Solenoid Valves
- PV**
Proportional Valves
- CE**
Coils & Electronics
- CB**
Cartpak Bodies
- BC**
Bodies & Cavities
- TD**
Technical Data

General Description

Normally Closed Proportional Flow Control Valve. For additional information see Technical Tips on pages PV1-PV5.

Features

- On-off type solenoids
- Low hysteresis
- PWM signal preferred
- Manual override standard
- All external parts zinc plated

Specifications

Rated Flow Valve Fully Open	53 LPM (14 GPM)
Maximum Inlet Pressure	210 Bar (3000 PSI)
Hysteresis @ 200 Hz PWM	4%
Cracking (Dead band)	20% - 30% of Input Signal
Frequency	100 - 400 Hz (200 Hz Preferred)
Maximum Control Current	12 VDC 24 VDC 3.53A 1.79A
Cartridge Material	All parts steel. All operating parts hardened steel.
Operating Temp. Range/Seals	-34°C to +121°C (Nitrile) (-30°F to +250°F) -26°C to +204°C (Fluorocarbon) (-15°F to +400°F)
Fluid Compatibility/Viscosity	Mineral-based or synthetic with lubricating properties at viscosities of 45 to 2000 SSU (6 to 420 cSt)
Filtration	ISO-4406 18/16/13, SAE Class 4
Approx. Weight	0.32 kg (0.7 lbs.)
Cavity	C12-2 (See BC Section for more details)
Form Tool	Rougher None Finisher NFT12-2F

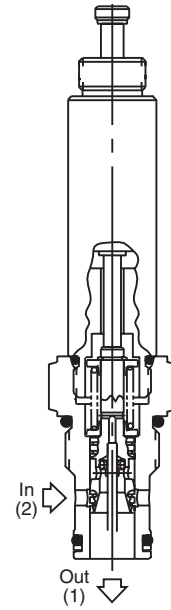
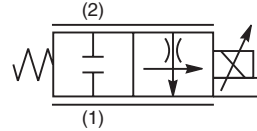

Performance Curves

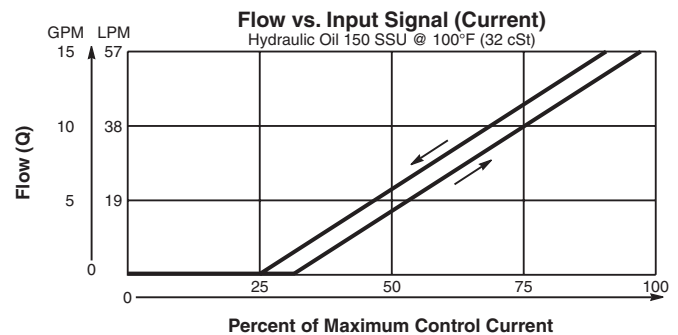
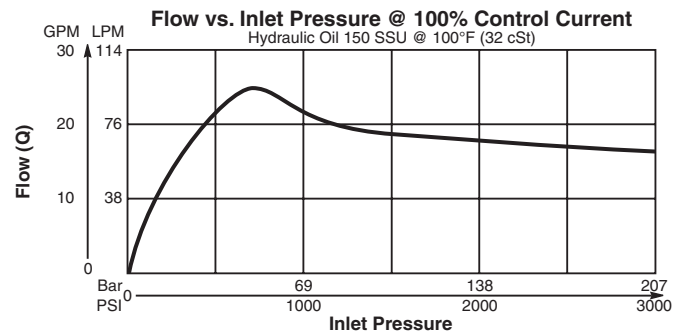
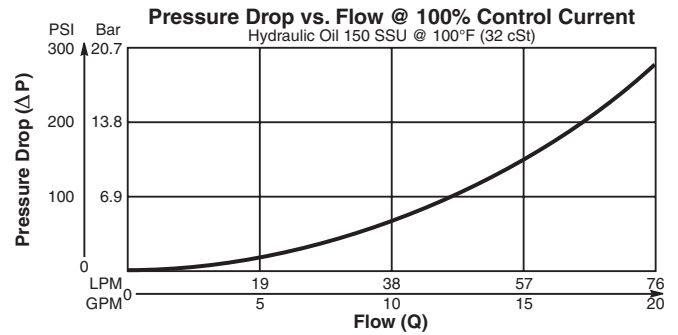

Dimensions Millimeters (Inches)

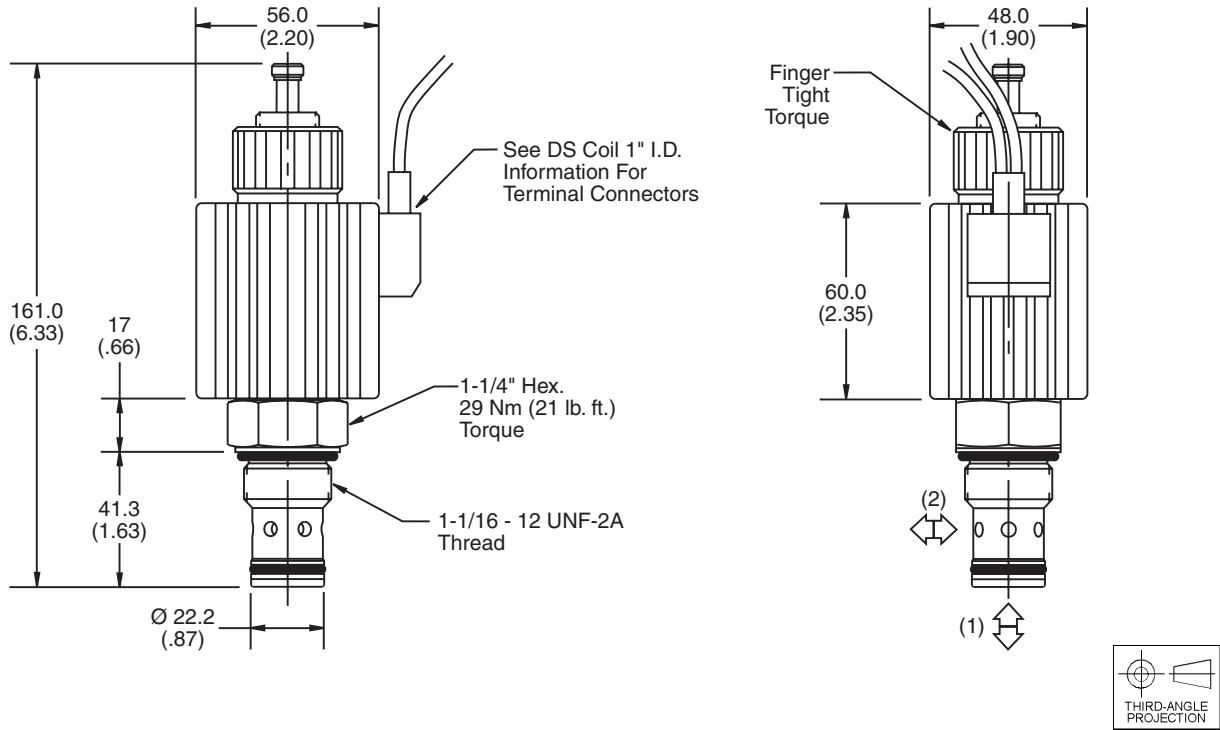

Ordering Information

DF122C14		
12 Size Normally Closed Proportional Flow Control Valve	Override Options	Seals

Highlighted represents preferred options that offer the shortest lead times. Other options may be available, but at extended lead times.

Coil(s) sold separately. Please see section CE of this catalog, 1" Coil (DS series), for ordering information.

Code	Override Options
Omit	Push Type with Extended Rod

Code	Seals / Kit No.
Omit	Nitrile / Buna-N (SK12-2)
V	Fluorocarbon / (SK12-2V)

Order Bodies Separately
 See section BC

B12	-	2	-	
12 size		2-Way Cavity		Port Size

Code	Porting / Body Material
12T	SAE-12 / Steel (5000 PSI)
A12T	SAE-12 / Aluminium (3000 PSI)

- CV
- Check Valves
- SH
- Shuttle Valves
- LM
- Load/Motor Controls
- FC
- Flow Controls
- PC
- Pressure Controls
- LE
- Logic Elements
- DC
- Directional Controls
- MV
- Manual Valves
- SV
- Solenoid Valves
- PV
- Proportional Valves
- CE
- Coils & Electronics
- CB
- Carpak Bodies
- BC
- Bodies & Cavities
- TD
- Technical Data